

# Simulation-To-Flight (STF-1): A Mission to Enable CubeSat Software-based Validation and Verification

Justin Morris<sup>1</sup>, Scott Zemerick<sup>2</sup>, Matt Grubb<sup>3</sup>, and John Lucas<sup>4</sup>  
*NASA Goddard Space Flight Center IV&V Program, Fairmont, WV, 26554, USA*

Majid Jaridi<sup>5</sup>, Jason N. Gross<sup>6</sup>, Nicholas Ohi<sup>7</sup>, John A. Christian<sup>8</sup>, Dimitris Vassiliadis<sup>9</sup>, Anand Kadiyala<sup>10</sup>, Matthew Pachol<sup>11</sup>, Jeremy Dawson<sup>12</sup> and Dimitris Korakakis<sup>13</sup>  
*West Virginia University, Morgantown, WV, 26506, USA*

*and*

Robert Bishop<sup>14</sup>  
*University of South Florida, Tampa, FL, 33620*

**The Simulation-to-Flight 1 (STF-1) CubeSat mission aims to demonstrate how legacy simulation technologies may be adapted for flexible and effective use on missions using the CubeSat platform. These technologies, named NASA Operational Simulator (NOS), have demonstrated significant value on several missions such as James Webb Space Telescope, Global Precipitation Measurement, Juno, and Deep Space Climate Observatory in the areas of software development, mission operations/training, verification and validation (V&V), test procedure development and software systems check-out. STF-1 will demonstrate a highly portable simulation and test platform that allows seamless transition of mission development artifacts to flight products. This environment will decrease development time of future CubeSat missions by lessening the dependency on hardware resources. In addition, through a partnership between NASA GSFC, the West Virginia Space Grant Consortium and West Virginia University, the STF-1 CubeSat will hosts payloads for three secondary objectives that aim to advance engineering and physical-science research in the areas of navigation systems of small satellites, provide useful data for understanding magnetosphere-ionosphere coupling and space weather, and verify the performance and durability of III-V Nitride-based materials.**

---

<sup>1</sup> Computer Engineer, NASA IV&V's Independent Test Capability (ITC)

<sup>2</sup> NASA IV&V ITC Contract Engineer, TMC Technologies

<sup>3</sup> Systems Engineer, NASA IV&V ITC Contract, RSI-Tech

<sup>4</sup> Systems Engineer, NASA IV&V ITC

<sup>5</sup> Professor and Director, West Virginia Space Grant Consortium

<sup>6</sup> Assistant Professor, Department of Mechanical and Aerospace Engineering (MAE), AIAA Senior Member

<sup>7</sup> Undergraduate Research Assistant, Department of MAE, AIAA Student Member

<sup>8</sup> Assistant Professor, Department of MAE, AIAA Senior Member

<sup>9</sup> Research Associate Professor, Department of Physics and Astronomy

<sup>10</sup> Graduate Student, Lane Department of Computer Science and Electrical Engineering (LCSEE)

<sup>11</sup> Graduate Student, LCSEE

<sup>12</sup> Associate Professor, LCSEE

<sup>13</sup> Professor, LCSEE

<sup>14</sup> Dean of Engineering and Professor, College of Engineering, AIAA Fellow

## I. Introduction

STF-1 has been selected for launch manifestation through the 2015 round of NASA's CubeSat Launch Initiative. The development of STF-1 started in March 2015 and the 3U CubeSat is scheduled to be launch ready by September 2016. The overall mission, including flight software and system engineering, integration and test is being led by the NASA IV&V Independent Test Capability (ITC) team. STF-1 will host a suite of space science and technology payloads from multiple research groups at West Virginia University. In addition, as the state of West Virginia's first satellite mission, the West Virginia Space Grant Consortium is engaging WV's youth through STF-1 via outreach program's such as the development of the project's mission patch. This paper will provide an overview of the STF-1 mission, and is organized as follows: Section II will outline the mission's objectives including its primary objective of demonstrating CubeSat software tools, its three secondary technical and science objectives, and its statewide outreach plans. Section III will detail STF-1's engineering design in terms of component selection, mass, power, volume planning, telecommunications architecture and operational models.

## II. Background & Mission Objectives

### A. Primary Objective

The primary objective of the STF-1 mission is to demonstrate the utility of the software-only simulation technologies developed by the NASA IV&V Independent Test Capability Team (ITC). These simulations model the spacecraft hardware such that unmodified flight software (FSW) binaries can be dynamically tested in a test-as-you-fly, "digital twin" simulator. The STF-1 mission will demonstrate a highly portable simulation and test platform that allows seamless transition of mission development artifacts to flight products. This environment will reduce risk and decrease the development time of future CubeSat missions by lessening the dependency on hardware resources.

The FSW framework chosen for STF-1 is the Core Flight System (CFS), developed at Goddard Space Flight Center (GSFC). Aside from its proven flight heritage, CFS, provides the benefit of supporting both flight hardware and a standard Linux environment typical of most personal computers. CFS utilizes the Operating System Abstraction Layer (OSAL), also developed by GSFC, which is a small software library that isolates the embedded software from the real time operating system. The OSAL enables the STF-1 FSW to execute in an environment such as Linux in a manner comparable to the flight hardware. A significant challenge to getting FSW to execute properly on Linux are the external satellite components (e.g., GPS, magnetometer) that must communicate with the processor over communication channels such as UART, SPI, or I2C.

The NASA Operational Small Satellite Simulator (NOS<sup>3</sup>) developed by ITC provides a solution to this problem by cleanly mimicking the protocol required by these components in a software-only abstraction layer. The external component can either be modeled by a software simulation, as done early in development, or plugged into the Linux machine to provide Hardware-in-the-Loop (HWIL) capability. NOS<sup>3</sup> is easily linked to the FSW using the default build system. The changes required for the simulation environment to communicate to the OSAL are unknown to the FSW, and allows the CFS compiled for simulation to be loaded to flight hardware. Figure 1 shows this environment where the bubbles represent the applications running in CFS and the boxes represent either hardware or simulated components.

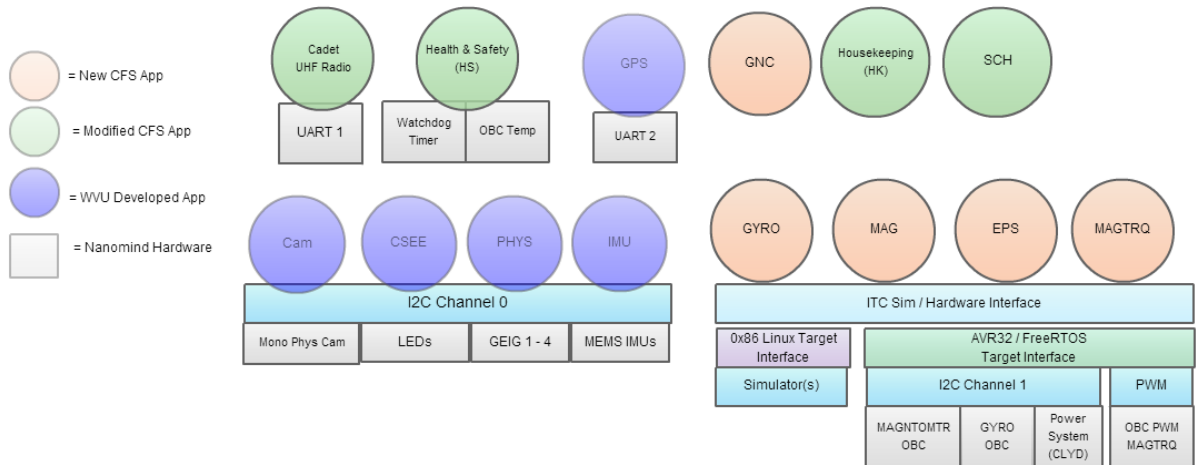
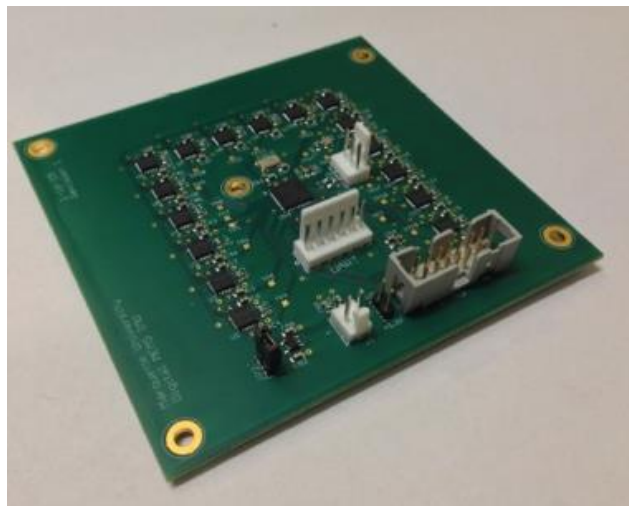

**Figure 1. FSW and Simulation Architecture**

## B. Secondary Objectives

### 1. MEMS IMU Swarm

Many modern CubeSat missions have a need for improved spacecraft navigation performance in order to meet more demanding scientific objectives. High-performance inertial measurement units (IMUs) are a key component in most precision navigation systems. Unfortunately, the size, weight, and power (SWaP) constraints of most CubeSats prohibit the use of common legacy IMU systems with the necessary performance. To address this deficiency, the research team has developed a new CubeSat IMU system employing a large cluster of redundant MEMS IMUs<sup>1</sup>. This IMU system, a prototype of which is shown in Figure 2, will be flown on STF-1 as part of a technology maturation plan. This prototype was developed under a Small Satellite Technology Partnership (SSTP) between West Virginia University, Marquette University, and the NASA Johnson Space Center. The version of the IMU cluster shown in Figure 2 will fly aboard a sounding rocket launched from NASA Wallops Flight Facility in late 2015 as part of NASA's Undergraduate Student Instrumentation Program (USIP). A subsequent version will be custom-built for STF-1.



**Figure 2. Gen2 IMU cluster that will fly aboard sounding rocket from NASA WFF in 2015. The subsequent iteration (Gen3) will fly aboard STF-1.**

### 2. GNSS Receiver and Precise Orbit Determination

Current state-of-the-art Global Positioning System (GPS) Precise Orbit Determination (POD) for Low-Earth Orbiting (LEO) spacecraft has achieved 1-cm level accuracy<sup>2</sup>, POD of a CubeSat platform has only been

demonstrated at the 1-10 meter level. In 2008, the first CubeSat mission to demonstrate dual-frequency GPS tracking was the CanX-2 mission<sup>3</sup>. Can-X2 flew a COTS Novatel OEM4-GL receiver, and was unable to retrieve useable carrier-phase tracking data. Nonetheless, CanX-2 successfully demonstrated meter-level post-processed orbit determination on a constrained nano-sat platform. UT-Austin demonstrated carrier-phase tracking on their FOTON receiver onboard a sounding rocket and is schedule to fly a FOTON on the ARMADILLO CubeSat mission. As more advanced CubeSat instruments with rigorous scientific objectives are matured, there is a need for advancing the accuracy of GPS POD on the CubeSat platform.

The baseline GPS experiment of STF-1 will consist of collecting 10-Hz dual-frequency psuedorange carrier-phase GPS observables over multiple hours from the Novatel OEM-615® receiver and post processing this data for a precise orbit using NASA JPL's GNSS Inferred Positioning System and Orbit Analysis Simulation Software (GIPSY-OASIS) package<sup>5</sup>. Multiple orbital periods will be collected such that separate data arcs can be processed with an overlapping period in order to assess inter-solution consistency. The goal of this experiment will be to obtain the best possible POD performance with GIPSY-OASIS despite the short data arcs and lack of CubeSat specific spacecraft model. With this baseline, the GPS experiment will then focus on power-constrained POD.

The lack of power resources on the CubeSat platform poses challenges for high-accuracy GPS POD. That is, in precision GPS POD applications, the fact that carrier-phase ambiguities remain constant while continuously tracking a satellite link is exploited within the estimation strategy. However, for power-constrained operations, such as on CubeSats, it is often beneficial to frequently duty-cycle the GPS receiver in order to save power. Unfortunately, upon each power-cycle, a new set of phase ambiguities is present, and these short non-continuous phase arcs will lead to a loss of POD solution accuracy. As such, the focus of STF-1 GPS experiment will be to develop and assess estimation strategies that will maximize POD accuracy from data obtained during duty-cycled operations. The developed methods will be assessed by comparing performance the baseline POD performance obtained from long duration continuous GPS data. In addition, Total Electron Content (TEC) estimates will be derived from the GPS data for use in the Magnetosphere-Ionosphere Coupling and Space Weather experiment.

### 3. Magnetosphere-Ionosphere Coupling and Space Weather

The STF-1 mission is poised to demonstrate WVU's capabilities in advanced space physics experimental and computational methods. With a polar or near-polar orbit that spans a range of ionospheric altitudes above 350 km the spacecraft will experience very different plasma regimes in the polar, mid-latitude, and equatorial regions. The space physics part of the payload will examine the following goals: magnetosphere-ionosphere coupling, intensity and distribution of very-low-frequency (VLF) waves, and space weather effects.

The coupling between magnetosphere and ionosphere depends primarily on the electromagnetic and convective stresses from the magnetosphere and on the ionospheric resistivity, which modulates the response to these stresses (Fig. 3). Electron precipitation at energies below 100 keV is an indicator of the magnetospheric state and modifies the nighttime ionospheric conductivity. A solid-state detector will be used to measure the flux of electrons precipitating from the plasma sheet with energies of 10, 30, and 100 keV. Over the polar caps the detector will effectively measure solar energetic particle fluxes. The accuracy of this experiment will rely on attitude information from the inertial measurement unit (IMU) and the magnetometer, which will be used to determine the magnetic field direction.

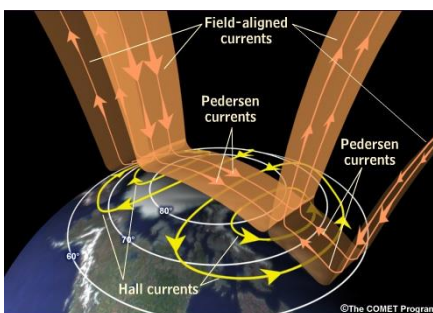

**Figure 3. Earth's ionosphere is a dynamic plasma environment driven by the solar illumination and magnetospheric electric fields, convection, and particle precipitation.**

Two fundamental properties of the ionosphere are the electron density and temperature. A Langmuir probe will be used to measure them as a function of latitude (Fig. 4). These measurements of the local plasma environment will be compared to regional measurements of the total electron content (TEC) derived from the GPS receiver.

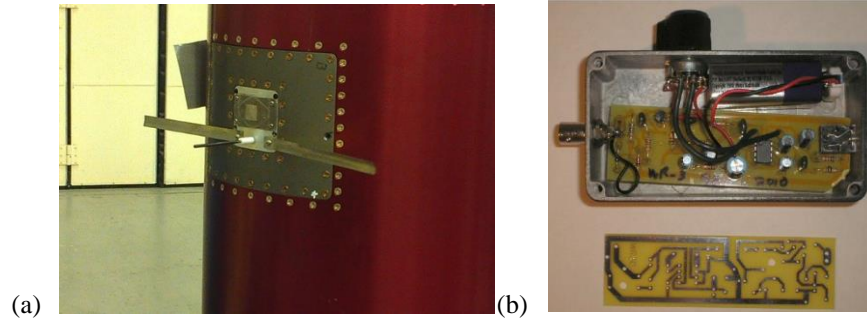

**Figure 4. (a) The WVU Langmuir probe in mission RSC2014 is shown attached to the fuselage of a sounding rocket prior to launch on June 26, 2014. (b) The VLF detector will be miniaturized from a prototype shown.**

VLF waves have important functions in energetic-electron precipitation and ionosphere-neutral atmosphere interactions. At subauroral magnetic latitudes  $\lambda=60-70^\circ$ , VLF intensities are related to scattering of radiation-belt electrons and heavier particles. At lower latitudes VLF waves are the result of natural processes (ionospheric disturbances) and anthropogenic effects (radio, television, and other communications; and ionospheric heating facilities). A VLF receiver will be used to obtain spectra in the 500 Hz to 500 kHz region with filters centered at 16 kHz, 64 kHz, and 256 kHz.

The effects of the space environment on technologies such as spacecraft are collectively called space weather. High fluxes of precipitating particles and high-temperature plasma can produce surface and deep dielectric charging on a CubeSat. Measuring these variables, especially at times of intense solar and/or ionospheric activity is important for monitoring spacecraft health and for understanding the effects of space on nitride-based materials described next.

In summary, measuring some of the fundamental properties of the space environment where STF-1 will operate is important for research and educational programs at WVU and relevant to other experiments of this mission.

#### 4. III-V Nitride-based materials

With increasing demand for remote and automated missions to be carried out in space and for space applications, reliable materials and sensor platforms are required. A precision optoelectronic sensor module containing arrays of light-emitting diodes (LEDs) and photodiodes (PDs) can be used for short-range distance measurement and shape rendering in such automated missions in space environment. The advancements in material sciences and optoelectronics have propelled the use of novel materials for generation and detection of various wavelengths of light. To avoid signal saturation in the presence of solar spectrum, the wavelength range 380 - 450 nm<sup>6</sup> is best suitable for such sensor modules. III-V nitride materials are known for their wide direct bandgaps and the ability to form various alloys<sup>7</sup>. These materials, when synthesized along with apt combination of alloys show promise to generate light in the wavelength range<sup>8,9</sup>, and are suitable semiconductors for a variety of applications in optoelectronics. These materials, especially III-Nitride materials are known for their radiation hardness and the ability to operate at extreme temperatures<sup>10-14</sup>. Due to harsh radiation and extreme temperatures observed in space environment, the sensors need certain level of shielding for reliability of the devices and its functionality<sup>10</sup>. However, the shielding for an optoelectronic sensor involving light-emitting diodes (LEDs) and photodiodes (PDs) obstructs the path of light and compromises its functionality. A proposed sensor platform with minimal shielding will improve and extend the sensing capability in the space environment. With the CubeSat launch, we intend to test the durability of the materials used in the sensor (GaN, InGaN etc.) and the performance of the core components of the sensor (LEDs and PDs) at various conditions of space atmosphere. The mission's objectives will be understand

the effects of radiation and temperature on these materials and determine the longevity of the devices under minimal shielding. This critical data is derived by performing basic experiments like the current-voltage and electroluminescence characteristics of the devices as shown in the Figure 5. A variety of space certified sensors will be used to measure temperature and radiation information in the space environment. This data will provide a trend for the basic experiments that are intended to be performed in space.

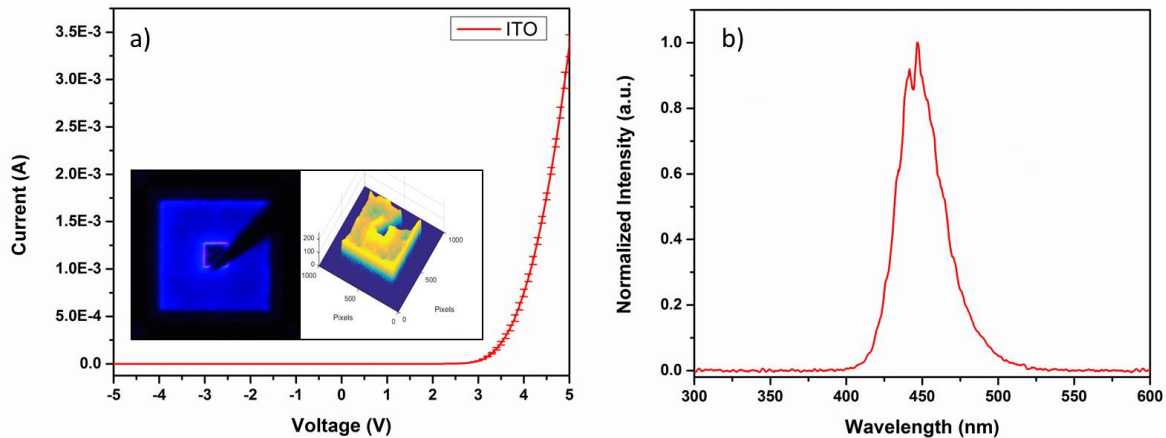
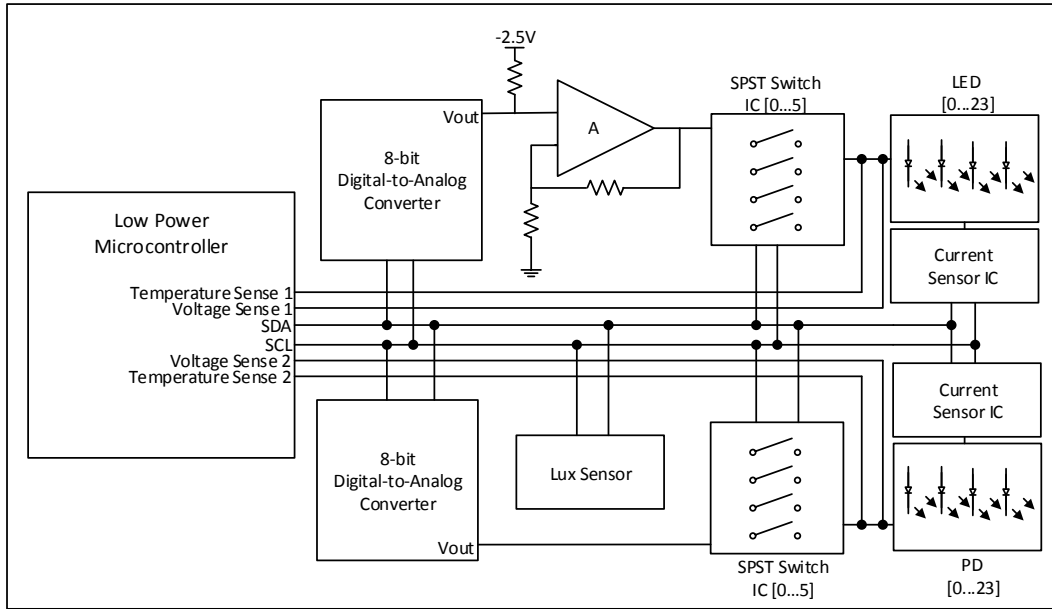

**Figure 5 a) Current Voltage characteristics (Inset: Optical Image of LED) b) Electroluminescence spectra with a peak at 450 nm**

Experimental Plan: With extensive experience in research and development in LEDs and PDs<sup>15,16,17</sup>, we shall utilize our growth and fabrication methods produce LED and PD modules evaluated in this CubeSat launch. A series of tests will be performed on these devices to collect the current-voltage characteristics (IV), detect the peak wavelength and device diagnostics at regular intervals of time while in space. For the current-voltage (I-V) characteristics, the input voltage will be ramped from -5V to 5V in steps of 0.1V, and the respective device currents will be collected and transmitted to ground. These I-V characteristics collected over time will provide information necessary for to understand how device performance may be impacted by the space environment. The peak wavelength detection will be performed by an array of spatially-arranged commercial PDs with a narrow range of input wavelengths. When the test devices are turned on at certain operating voltage, the peak wavelength will be determined by the spatial information gathered from the array of PDs, as well as the relative intensity measurement. This data will indicate whether or not the LEDs experience emission the peak shift due to changes in the environment. The temperature information collected at the time of these tests will be gathered from an onboard temperature sensor. Observation of the trends in the data collected will be useful for optimising the design of nitride-based devices for space applications. Similar tests will be performed on the commercially fabricated control devices, and the data will be collected by the test devices.

To perform basic experiments and data collection, an integrate CubeSat LED characterization system is required.. The following block diagram shown in Figure 6. illustrates a low-cost, CubeSat-sized LED/PD characterization system. Several factors were considered in the design to meet the power and data constraints of the CubeSat platform, including: driving current, control of voltage ramps, switching, measurement accuracy, and data storage. . The brain of the system is a low power microcontroller, which enables programmable configuration of switching, voltage ramping, voltage sensing, and data management. The microcontroller communicates directly with the main onboard computer of the CubeSat to control the timing of experiments, relay acquired data, and ensure data is delivered to the ground station.





**Figure 6. Block diagram of the portable characterization system**

The first of the experiments is to obtain I-V characteristics of the device. To achieve this a voltage ramp is generated using an 8-bit digital-to-analog IC ramping from 0V to 5V. Following this, a high-current-output operational amplifier is configured with a gain of 2 and an input bias of -2.5V. This allows the LEDs to be ramped from -5V to 5V and provide the necessary current to avoid voltage capping. For redundancy, the experiment is to be performed on multiple devices. Due to this six single throw, single throw switching ICs with high current throughput are used for selection of device by command. Each switching IC has enough current capacity to pass the necessary amount of current from the amplification stage to the LED. Device selection is achieved simply by using the I2C enabled addressing. Finally, the current drawn by the devices needs to be measured, ideally using a current sensor with a low resistance. This reduces current limiting and provides a simple communication between the microcontroller and sensor IC. With a sourcing configuration and the selected devices, the CubeSat LED I-V characterization system is designed to withstand the temperatures of the thermosphere and beyond, and will allow for the experimentation of III-V based GaN LEDs in space. Alongside this current sensor, a set of commercial photodiodes, lux and temperature sensors are present on a separate circuit board that are used for providing feedback and gathering further critical information. Both onboard temperature and the temperature of the device carrier are collected using the temperature sensors. The lux sensor is used to collect lux information when the LED is in 'off' and 'on' states. The difference in the lux information in each state is used to determine whether the devices are lighting up on command. The commercial photodiode 'control' array is used to determine any shift in the emission wavelength of the LEDs based on temperature or any effects experienced in space. All data will be temporarily stored on the attached EEPROM of the board. After the execution of the experiments, the data is packaged according to the communication protocol and transferred to the main onboard computer via I2C. With the ability of device selection and ease of configuration, the CubeSat ready characterization system will be helpful in understanding the performance characteristics of LEDs, PDs or any semiconductor devices in space.

### C. Statewide Outreach Plans and Programs

An important component of the STF-1 mission is the public and K-12 outreach program. The team plans to provide West Virginia high school and local college students the unique opportunity to be involved with the mission. NASA West Virginia Space Grant Consortium (WVSGC) will be coordinating this effort throughout the state of West Virginia. WVSGC is state-wide program with 12 academic affiliates and six high technology and research-oriented organizations. The Consortium is headquartered in the Statler College of Engineering and Mineral Resources at West Virginia University. Our vision includes providing K-16 students with hands-on experiences in STEM to inspire and prepare them for active participation in our nation's future space program.

Outreach plans for the STF-1 includes preparation of brochures and educational material on general space related topics as well as specific guidebooks and activity booklets on CubeSats. We will also use NASA-produced material on space exploration, satellite operation, Space Station facts, etc. We will fully take advantage of the expertise and the network available at the Educator Resources Center at the NASA IV&V Facility in Fairmont, WV to reach a large number of K-12 schools in the state. Cardboard models of our CubeSat will be produced and distributed to classrooms, along with the Educator’s Guide for teachers.

At the college level, we will get the local chapters of Student Partnership for the Advancement of Cosmic Exploration (SPACE) involved in distributing material and the news about STF-1 mission. We will also send our team to make presentations at SPACE meetings in the colleges affiliated with WVSGC.

### III. Mission Implementation

This section will provide an overview of each of the satellites main subsystems. Figure 7 shows the physical stack of components contained in the 3U structure, with unmodeled components shown as gray boxes for sizing. The placement of the components will be determined based upon vital connections, weight distribution, and thermal properties during the integration of the spacecraft.

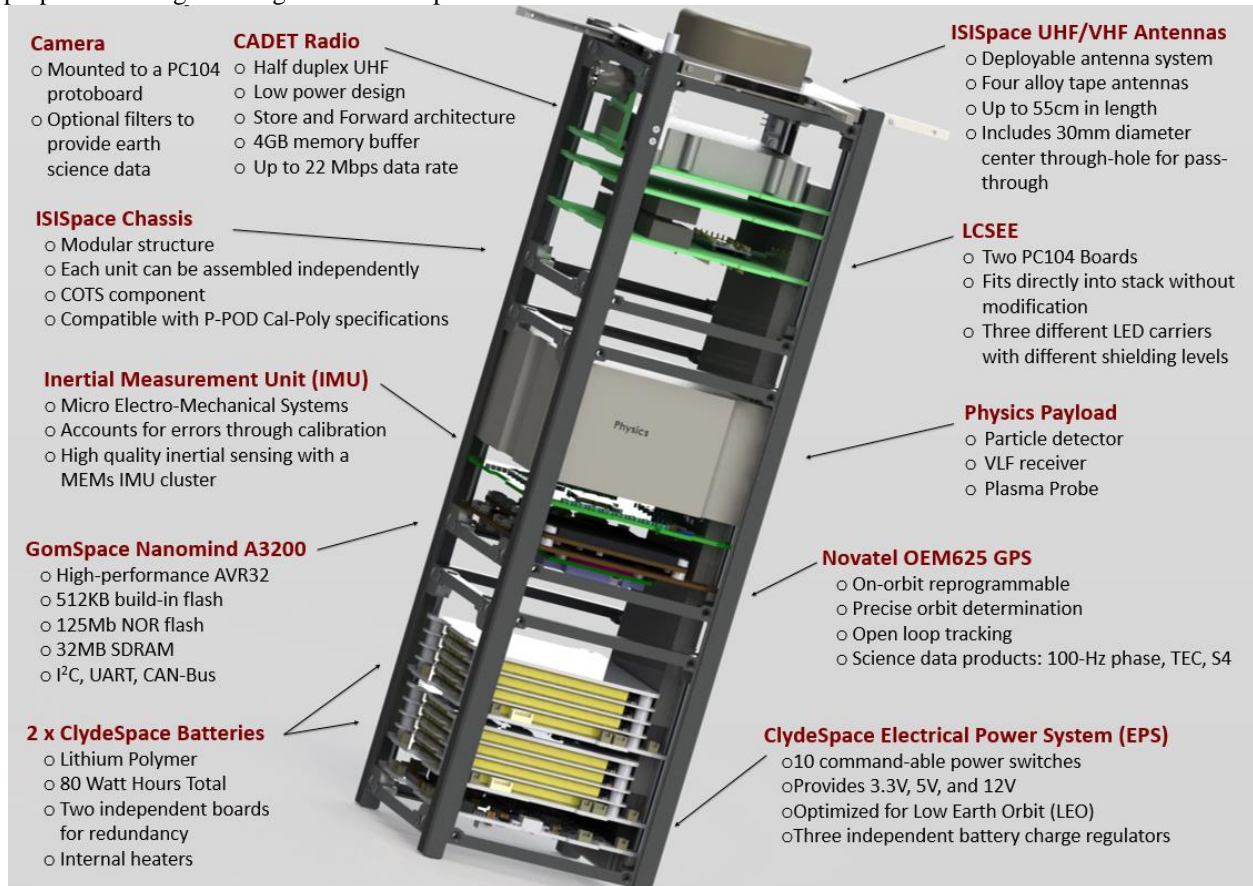

Figure 7. STF-1 Component Diagram

Whenever possible, STF-1 leverages the software and hardware design of the GSFC 6U Dellingr CubeSat mission in order to reduce schedule risk and lower development time and complexity.

#### A. Command and Data Handling Subsystem

The STF-1 Command and Data Handling (C&DH) system utilizes the newest revision of the GOMSpace Nanomind on-board computer (OBC), the A3200; this processor was chosen due to its high on board memory capacity, expansion board for mounting the Novatel GPS receiver, and the flight heritage of the COTS Nanomind boards. The STF-1 FSW will be comprised of CFS/OSAL running on FreeRTOS. This architecture is very similar to that of the



Dellinger mission, for which CFS has already been ported to run on FreeRTOS. The majority of the operations of STF-1 will be automated through the CFS scheduler, however individual commands and updated schedules can be ingested from the ground.

## **B. Power Systems**

The power system for STF-1 will be a COTS Electrical Power System (EPS) from Clydespace. The EPS safely manages charging from the external solar panels, and monitors over current and under/over voltages of the batteries. Two Clydespace Lithium Polymer batteries will be connected in parallel to achieve a total power capacity of 80Whrs, and provide redundancy in the event of single battery failure. The batteries each have their own microprocessor controlled heating system designed to maintain their nominal temperature range. The solar panels will be designed and built in house in partnership with GSFC. The panels will cover each of the X and Y faces of the CubeSat, as well as the positive Z face. Through dynamic power-simulations it is estimated that the satellite will have a net power generation of 6Whrs per orbit while in charging mode. The power of the system will be closely monitored by the Health and Safety application in CFS and experiments will be scheduled accordingly. It is also important to note that all electrical systems will be powered off until the deactivation of two separation switches when deployed from the dispenser in accordance with launch vehicle requirements.

## **C. Communications Systems and Ground Station**

STF-1 will communicate with the CubeSat Ground Station Network at Wallops Flight Facility (WFF) over a government licensed UHF band. The system will include a flight-proven COTS UHF transceiver, the L3 Cadet, along with an ISISpace deployable antenna mounted on the 3U structure. This transceiver is half duplex, in which a command will be sent from Wallops to trigger a downlink, and has a data rate up to 3.0Mbps while consuming only 12W transmitting, 0.3W receiving, and 0.05W in standby mode. The Cadet uses a “store and forward” function allowing the included 4GB memory buffer to store data as it is offloaded from the Nanomind OBC. The connection between the OBC and Cadet is a UART from which the Nanomind can also receive FSW updates and commands. The application for National Telecommunications and Information Administration (NTIA) frequency licensing is currently in process with assistance of GSFC personnel.

## **D. Environmental Monitoring System**

Though not a necessary requirement for mission success, STF-1 will have the necessary components for attitude determination, temperature and magnetic field measurement, and coarse sun sensing. The main objective of the Environmental Monitoring System (EMS) is to collect data on the CubeSat environment that can be stored in telemetry and sent to ground. This telemetry will provide better environmental models for the NOS<sup>3</sup> simulator to be used on future missions. Coarse sun sensing will be achieved through photo diodes on the solar panels, and attitude will be provided from the IMU cluster. The Novatel GPS receiver will provide position, velocity and time. Temperature sensors will be spread throughout the CubeSat bus, and on the outer faces of the solar panels. The magnetometer is included in the OBC package.

In addition to environmental sensors, STF-1 will include a camera with a 2MP OV2640 CMOS sensor. This camera will be fully commandable over the I2C bus. A filter employed on the camera lens will allow STF-1 to monitor water levels, and vegetation on global scale. This camera will allow the mission operators to check the status of the deployable antenna system. Aside from the science merits, the camera will provide an additional avenue for outreach in the state of WV.

## **E. Mechanical Structure and CubeSat Bus**

All launch services requirements as specified in LSP-REQ-317.01 will be met. The 3U structure of STF-1, provided by ISISpace, will contain all components and wiring, and will not exceed the size requirements of 34cmx10cmx10cm, with a total weight less than 4kg. The “CubeSat Kit (CSK) Bus” as specified by Pumpkin is used for all on board COTS components, requiring the science experiments to conform to the same standard. The unallocated pins in the CSK bus will be used for any wiring that must extend through the 3U structure. This will reduce external wiring and provides pins for a science I2C bus, separate from critical components such as power system telemetry on the primary bus.

## IV. Conclusion

This paper presented an overview of the STF-1 3U CubeSat mission in terms of its objectives and implementation plans. STF-1 is currently being developed through collaboration between NASA IV&V and WVU engineers and scientists. The STF-1 will enable a test-as-you-fly “digit twin” testing capability for future CubeSat missions, and as WV’s first CubeSat will provide an opportunity for a group of WVU engineers and scientist to perform technology demonstrations and collect critical data to advance their research. The 3U CubeSat is scheduled to be completed September 2016, and will be manifested for flight as a secondary payload through NASA’s CSLI program.

## Acknowledgments

This work was supported by the West Virginia Space Grant Consortium, the West Virginia University (WVU) Statler College of Engineering and Mineral Resources, WVU Mechanical and Aerospace Engineering, WVU Lane Science of Computer Science and Electrical Engineering, WVU Research Corporation and NASA IV&V IRAD funds.

## References

- <sup>1</sup>Greenheck, D.R., Bishop, R.H., Jonardi, E.M., and Christian, J.A., "Design and Testing of a Low-Cost MEMS IMU Cluster for SmallSat Applications," 28th Annual AIAA/USU Conference on Small Satellites, Logan, UT, 2-7 August 2014.
- <sup>2</sup>Haines, B. J., Y. E. Bar-Sever, W. I. Bertiger, S. D. Desai, and P. Willis, "One centimeter orbit determination for Jason-1: New GPS-based strategies," *J. Marine Geodesy*, 27 (1-2), 299-318, 2004.
- <sup>3</sup>Kahr, Erin, Kyle O’Keefe, and Susan Skone. "Optimizing Tracking and Acquisition Capabilities for the CanX-2 Nanosatellite’s COTS GPS Receiver in Orbit." *ION GNSS 2010* (2010): 21-24.
- <sup>4</sup>Glenn Lightsey, E., et al. "Demonstration of a space capable miniature dual frequency GNSS receiver." *Navigation* 61.1 (2014): 53-64.
- <sup>5</sup>“GIPSY-OASIS” <https://gipsy-oasis.jpl.nasa.gov/> [Accessed: May 27, 2015]
- <sup>6</sup>Y. Ngu, M. C. Peckerar, D. Sander, C. R. Eddy, M. A. Mastro, J. K. Hite, R. T. Holm, R. L. Henry and A. Tuchman, "Array of two UV-wavelength detector types," *IEEE Transactions on Electron Devices*, vol. 57, no. 6, pp. 1224-1229, 2010.
- <sup>7</sup>E. F. Schubert, *Light-Emitting Diodes*, Cambridge: Cambridge University Press, 2003.
- <sup>8</sup>M. Funato, M. Ueda, Y. Kawakami, Y. Narukawa, T. Kosugi, M. Takahashi and T. Mukai, "Blue, Green, and Amber InGaN/GaN light-emitting diodes on semipolar {1122} GaN bulk substrates," *Japanese Journal of Applied Physics*, vol. 45, no. 26, pp. 659-662, 2006.
- <sup>9</sup>S. J. Chang, W. C. Lai, Y. K. Su, J. F. Chen, C. H. Liu and U. H. Liaw, "InGaN-GaN Multiquantum-well Blue and Green Light-Emitting Diodes," *IEEE Journal on Selected Topics in Quantum Electronics*, vol. 8, no. 2, pp. 278-283, 2002.
- <sup>10</sup>H. C. Chiamori, M. Hou, C. A. Chapin, A. Shankar, D. G. Senesky, "Characterization of gallium nitride microsystems within radiation and high-temperature environments", *Reliability, Packaging, Testing, and Characterization of MOEMS/MEMS, Nanodevices, and Nanomaterials XIII*, Proc. SPIE, vol. 8975, 2014.
- <sup>11</sup>C. Luan, Z. Lin, Y. Lü, Z. Feng, J. Zhao, Y. Zhou and M. Yang, "Comparison for the carrier mobility between the III-V nitrides and AlGaAs/GaAs heterostructure field-effect transistors", *J. Semicond.*, vol. 35, no. 9, p. 094007, 2014.
- <sup>12</sup>S. Khanna, D. Estan, A. Houdayer, H. Liu and R. Dudek, "Proton radiation damage at low temperature in GaAs and GaN light-emitting diodes", *IEEE Trans. Nucl. Sci.*, vol. 51, no. 6, pp. 3585-3594, 2004.
- <sup>13</sup>R. L. Patterson, L. Z. Scheick, J. M. Lauenstein, M. C. Casey and A. Hammoud, "Radiation and Thermal Cycling Effects on EPC1001 Gallium Nitride Power Transistors," NASA Electronic Parts and Packaging Program, 2012.
- <sup>14</sup>L. Lv, X. Ma, J. Zhang, Z. Bi, L. Liu, H. Shan, Y. Hao, "Proton Irradiation Effects on AlGaIn/AlN/GaN Heterojunctions", *IEEE Trans. Nucl. Sci.*, vol. 62, no. 1, pp. 300-306, 2015.
- <sup>15</sup>L. E. Rodak and D. Korakakis, "Influence of the interface on growth rates in AlN/GaN short period superlattices via metal organic vapor phase epitaxy," *Applied Physics Letters*, vol. 90, no. 20, 2011.<sup>16</sup>A. Kadiyala, K. Lee, L. E. Rodak, L. A. Hornak, D. Korakakis and J. Dawson, "Improvement in the light extraction of blue InGaIn/GaN-based LEDs using patterned metal contacts," *IEEE Journal of the Electron Devices Society*, vol. 2, no. 2, pp. 16-22, 2014.
- <sup>17</sup>J. Justice, A. Kadiyala, J. Dawson and D. Korakakis, "Group III-Nitride based electronic and optoelectronic integrated circuits for smart lighting applications," in *Material Research Society Symposium Proceedings*, Boston, MA, 2012.

