

# Structural Design Considerations for a 50 kW-Class Solar Array for NASA's Asteroid Redirect Mission

Thomas W. Kerslake<sup>1</sup>, Thomas G. Kraft<sup>2</sup>, John T. Yim<sup>3</sup> and Dzu K. Le<sup>4</sup>  
NASA Glenn Research Center, Cleveland, Ohio, 44135

NASA is planning an Asteroid Redirect Mission (ARM) to take place in the 2020s. To enable this multi-year mission, a 40 kW class solar electric propulsion (SEP) system powered by an advanced 50 kW class solar array will be required. Powered by the SEP module (SEPM), the ARM vehicle will travel to a large near-Earth asteroid, descend to its surface, capture a multi-metric ton (t) asteroid boulder, ascend from the surface and return to the Earth-moon system to ultimately place the ARM vehicle and its captured asteroid boulder into a stable distant orbit. During the years that follow, astronauts flying in the Orion multipurpose crew vehicle (MPCV) will dock with the ARM vehicle and conduct extra-vehicular activity (EVA) operations to explore and sample the asteroid boulder. This paper will review the top structural design considerations to successfully implement this 50 kW class solar array that must meet unprecedented performance levels. These considerations include beyond state-of-the-art metrics for specific mass, specific volume, deployed area, deployed solar array wing (SAW) keep in zone (KIZ), deployed strength and deployed frequency. Analytical and design results are presented that support definition of stowed KIZ and launch restraint interface definition. An offset boom is defined to meet the deployed SAW KIZ. The resulting parametric impact of the offset boom length on spacecraft moment of inertias and deployed SAW quasistatic and dynamic load cases are also presented. Load cases include ARM spacecraft thruster plume impingement, asteroid surface operations and Orion docking operations which drive the required SAW deployed strength and damping. The authors conclude that to support NASA's ARM power needs, an advanced SAW is required with mass performance better than 125 W/kg, stowed volume better than 40 kW/m<sup>3</sup>, a deployed area of 200 m<sup>2</sup> (100 m<sup>2</sup> for each of two SAWs), a deployed SAW offset distance of nominally 3-4 m, a deployed SAW quasistatic strength of nominally 0.1 g in any direction, a deployed loading displacement under 2 m, a deployed fundamental frequency above 0.1 Hz and deployed damping of at least 1%. These parameters must be met on top of challenging mission environments and ground testing requirements unique to the ARM project.

## Nomenclature

°	=	angular degree
ACS	=	attitude control system
ARM	=	asteroid redirect mission
ARV	=	asteroid redirect vehicle
B-frame	=	body frame
°C or C	=	Celsius
CAD	=	computer aided design

<sup>1</sup> ARM SEP Module solar array lead, Power Architecture and Analysis Branch, 21000 Brookpark Rd., Mail Stop 142-6.

<sup>2</sup> Structures and Mechanisms Senior Engineer, Mechanisms and Tribology Branch, 21000 Brookpark Rd., Mail Stop 86-12, and AIAA Member.

<sup>3</sup> Propulsion Engineer, In-Space Propulsion Systems Branch, 21000 Brookpark Rd., Mail Stop 301-3, and AIAA Member.

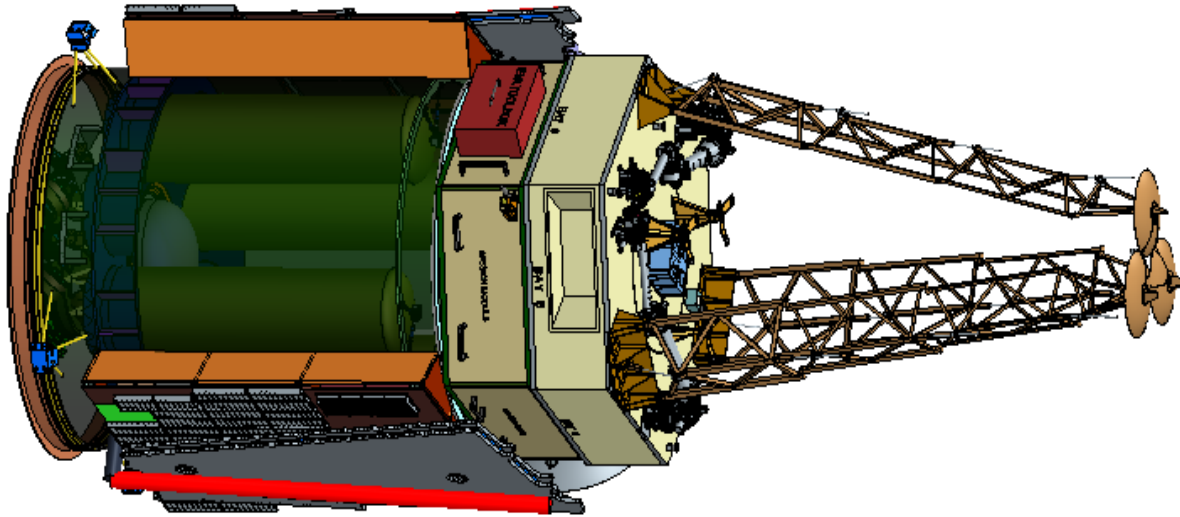
<sup>4</sup> Structural Dynamics & Control Senior Engineer, Intelligent Control and Autonomy Branch, 21000 Brookpark Rd., Mail Stop 77-1, and AIAA Member.

<i>CG</i>	=	center of gravity
<i>CM</i>	=	center of mass
<i>conops</i>	=	concept of operations
<i>CSI</i>	=	controls structures interactions
<i>dB</i>	=	decibel
<i>EP</i>	=	electric propulsion
<i>eV</i>	=	electron volt
<i>EVA</i>	=	extra-vehicular activity
<i>FEM</i>	=	finite element model
<i>g</i>	=	acceleration due to gravity
<i>GSE</i>	=	ground support equipment
<i>Hz</i>	=	hertz
<i>IDS</i>	=	international docking system
<i>ISS</i>	=	international space station
<i>IXX</i>	=	moment of inertia about the X axis
<i>I<sub>xy</sub></i>	=	moment of inertia about the X-Y plane
<i>I<sub>YY</sub></i>	=	moment of inertia about the Y axis
<i>I<sub>yx</sub></i>	=	moment of inertia about the Y-X plane
<i>I<sub>yz</sub></i>	=	moment of inertia about the Y-Z plane
<i>I<sub>zy</sub></i>	=	moment of inertia about the Z-Y plane
<i>IZZ</i>	=	moment of inertia about the Z axis
<i>KIZ</i>	=	keep in zone
<i>kg</i>	=	kilogram
<i>kW</i>	=	kilowatt
<i>m</i>	=	meter
<i>mm</i>	=	millimeter
<i>μm</i>	=	micrometer
<i>MBD</i>	=	multibody dynamics
<i>MCR</i>	=	mission concept review
<i>MOI</i>	=	moment of inertia
<i>MPCV</i>	=	multipurpose crew vehicle
<i>N</i>	=	newton
<i>NDS</i>	=	NASA docking system
<i>OD</i>	=	outer diameter
<i>PV</i>	=	photovoltaic
<i>RAMP2</i>	=	reacting and multi-phase 2 computer code
<i>PLIMP</i>	=	plume impingement computer code
<i>RCS</i>	=	reaction control system
<i>ROSA</i>	=	roll out solar array
<i>SADA</i>	=	solar array drive assembly
<i>SAW</i>	=	solar array wing
<i>SCS</i>	=	soft capture system
<i>Sec</i>	=	second
<i>SEP</i>	=	solar electric propulsion
<i>SEPM</i>	=	solar electric propulsion module
<i>SLS</i>	=	space launch system
<i>SR</i>	=	structural reference
<i>t</i>	=	metric ton
<i>TCS</i>	=	thermal control system
<i>W</i>	=	watt

## I. Introduction

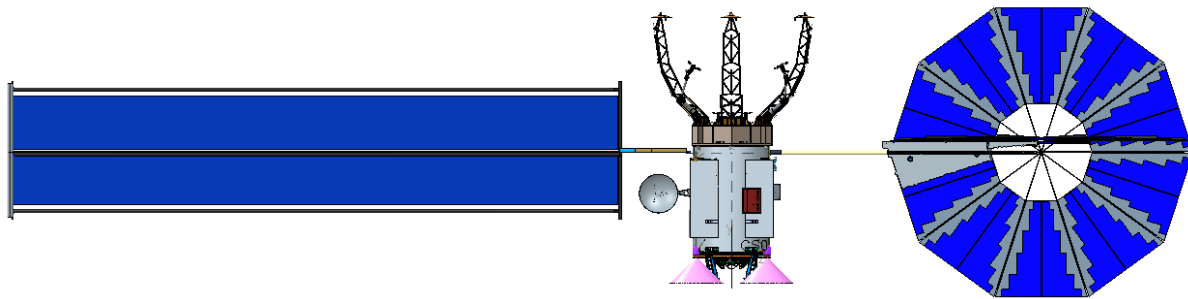
ON April 15, 2010, President Obama instructed NASA to develop the spacecraft and technologies needed to enable human exploration of a near Earth asteroid<sup>1</sup>. In response to this call, NASA plans to make use of a heavy lift

launch vehicle, such as the Space Launch System (SLS) rocket under development to launch large payloads into space, and the Orion multipurpose crew vehicle (MPCV), being developed to carry human explorers on missions beyond low



**Figure 1. ARM spacecraft concept with mission module (right) and the SEPM (left).**

Earth orbit. NASA and its commercial partners are also developing solar electric propulsion (SEP) and power technologies that enable efficient in-space transportation and ultimately, the Asteroid Redirect Mission (ARM). ARM pulls together all of these elements, the SLS, Orion and SEP technologies to meet the President’s goal of human asteroid exploration by the 2020s. To enable this multi-year mission, a 40 kW class solar electric propulsion (SEP) system powered by an advanced 50 kW class solar array will be required. Using the solar electric propulsion module (SEPM) in-space propulsion system and mission module, the ARM vehicle, such as the concept shown in Figure 1,



**Figure 2. Two candidate SAW technology concepts shown side by side for comparison: the Roll Out Solar Array (ROSA), left, and MegaFlex™, right. Ultimately, one SAW type (from competing advanced technologies) will be selected for both SAWs that will power the SEPM.**

will travel to a large near-Earth asteroid. Once there, the vehicle will descend to the asteroid surface, capture a multi-metric ton (t) class asteroid boulder, ascend from the surface and return to the Earth-moon system. At this phase of the mission, the ARM vehicle and its captured asteroid boulder will be placed into a stable distant Earth-moon orbit. During the years that follow, astronauts flying in the Orion multipurpose crew vehicle (MPCV) will dock with the ARM vehicle and conduct extra-vehicular activity (EVA) operations to explore and sample the asteroid boulder. Two solar array wings (SAWs) will comprise the advanced solar array, with possible technology options including, but not limited to, those recently funded by NASA<sup>2</sup>: the Roll Out Solar Array (ROSA) and the MegaFlex™, as shown in Figure 2. Both of these options use flexible blankets on which the photovoltaic cells are mounted. Ultimately, only one advanced SAW technology option will be selected for both SAWs that power the SEPM. Each SAW offset boom is mounted to a single-axis solar array drive assembly (SADA).

This paper will review the top structural design considerations to successfully implement this 50 kW class solar array (25 kW class SAW) that must meet unprecedented performance levels. These considerations include beyond state-of-the-art metrics for specific mass, specific volume, deployed area, deployed keep in zone (KIZ), deployed strength and deployed frequency. Analytical and design results are presented that support definition of stowed KIZ and launch restraint interface definition. Also presented, is an offset boom with parametric length required to meet the deployed SAW KIZ. The resulting impact of boom length on spacecraft moment of inertias and deployed SAW quasistatic and dynamic load cases is discussed. The SAW deployed strength and damping requirements arise from loads from ARM spacecraft thruster plume impingement, asteroid surface operations and Orion docking operations.

## II. General Considerations

### A. Mass

At the Mission Concept Review (MCR) timeframe in early 2015, the mass allocation for each SAW, including offset boom, was 200 kg. This translates to a specific power value for the SAW of about 130 W/kg at beginning of life with a SAW power level of 26 kW at the SAW to SADA interface. Compared to a state-of-the-art rigid panel SAW meeting the same requirements, this specific power value is 2-3X higher. The requirement for low SAW mass will most likely drive the design solution to one of an advanced, flexible blanket SAW.

### B. Deployed SAW flexible blanket area

At the ARM MCR timeframe, the spacecraft load power, dominated by the electric propulsion subsystem power draw, led to a required 52 kW solar array approximate power level at beginning of life. Using state of the art, triple junction solar cells with 29% conversion efficiency, the ARM SEPM application requires a SAW flexible blanket area of about 100 m<sup>2</sup>. This translates to a deployed MegaFlex™ SAW diameter of about 12.5 m and a ROSA SAW about 5 m wide by 24 m long. The flexible blanket area sizing accounts for the appropriate power performance loss mechanisms including harnessing voltage drop, SAW integration factors, SAW operational factors and all natural and induced environmental degradation factors for the ARM mission.

### C. Others

Based on the concept of operations (conops) for ARM, the SAW must be deployed autonomously without the assistance of ground operators or on-orbit crew. During deployed operation, the SAWs must achieve a high level of strength and stiffness (further discussed below). Given the SAW deployed loading orientation cannot be controlled following credible failure modes of the SADA, SAW deployed acceleration requirements must be both in-plane and out-of-plane directions. The SEPM coordinate system has the Y axis along the longitudinal axis of the vehicle with the X-Z plane coincident with the SEPM to upper stage separation plane. SAWs are located in the direction of the +Z and -Z axes. See Figures 3a, 3b and 4 depicting this coordinate system.

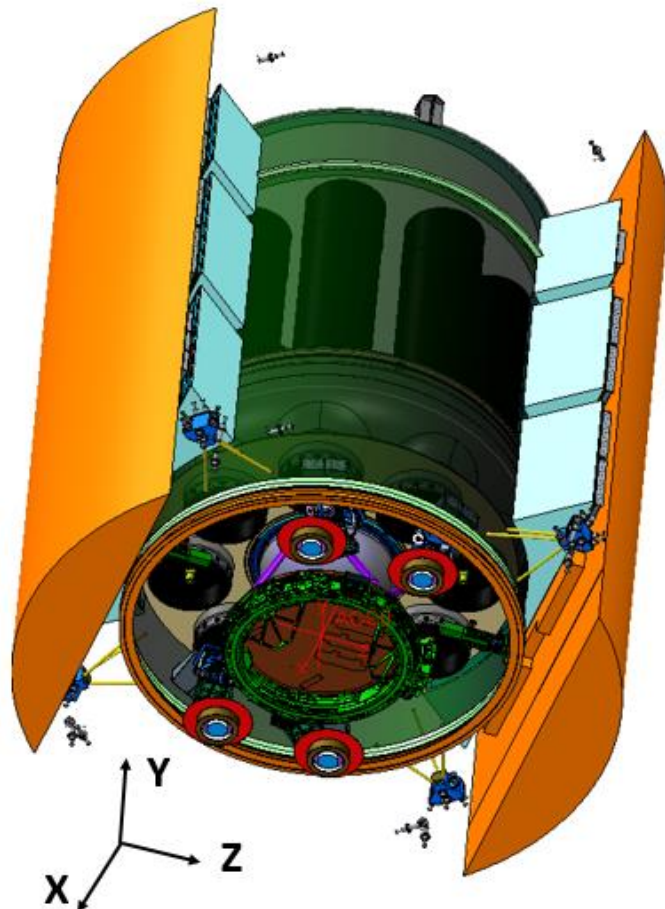


Figure 3a. Stowed SAW KIZ – shown as orange regions.

SAWs are located in the direction of the +Z and -Z axes. See Figures 3a, 3b and 4 depicting this coordinate system.

### III. Stowed SAW Considerations

#### D. Stowed SAW Keep in Zone

Given a structural optimized SEPM is short and squat, much of the available launch fairing volume is filled up leaving only a narrow radial gap into which the SAWs must fit. At the SEPM module base, longitudinal length is limited by the upper stage to spacecraft structural adaptor support. At the SEPM top, longitudinal length is constrained

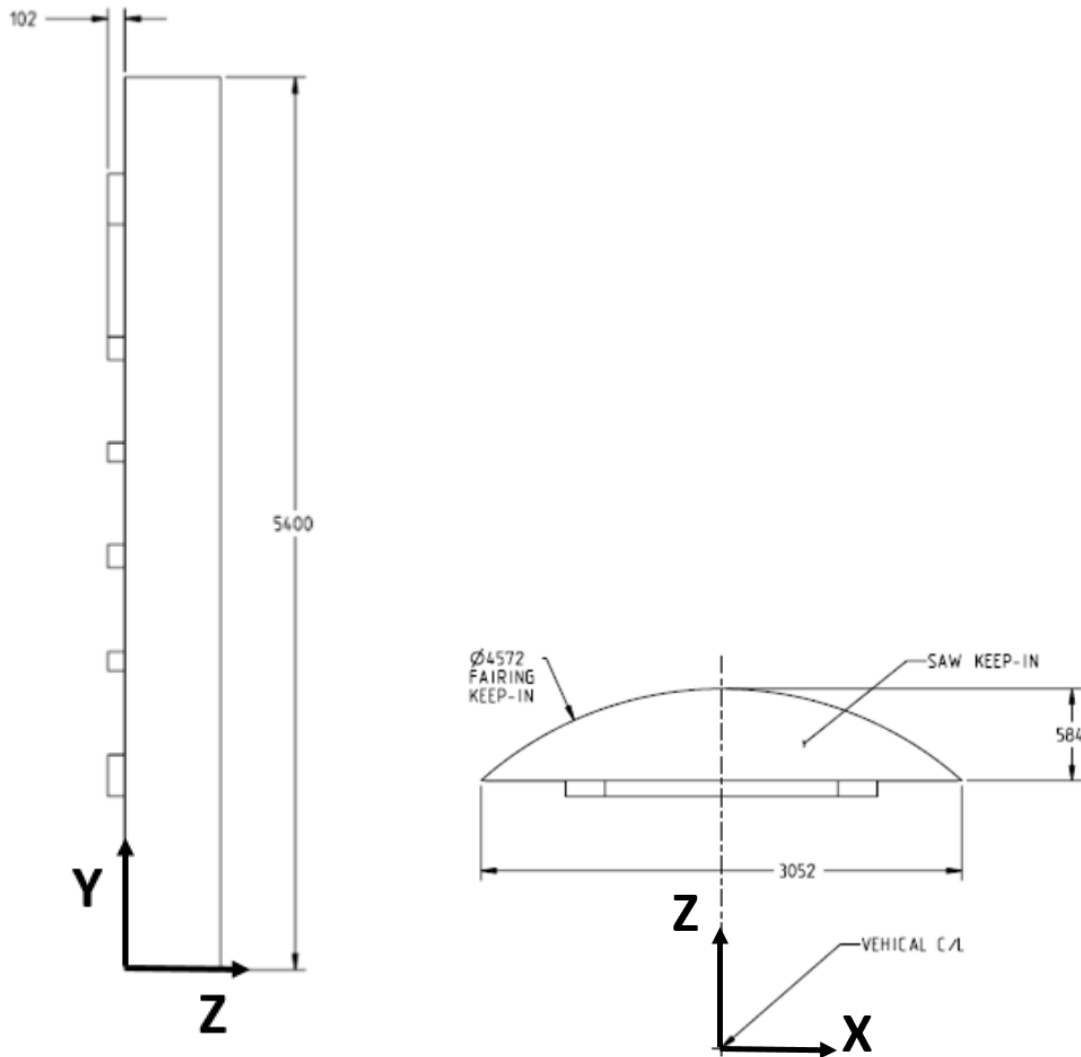
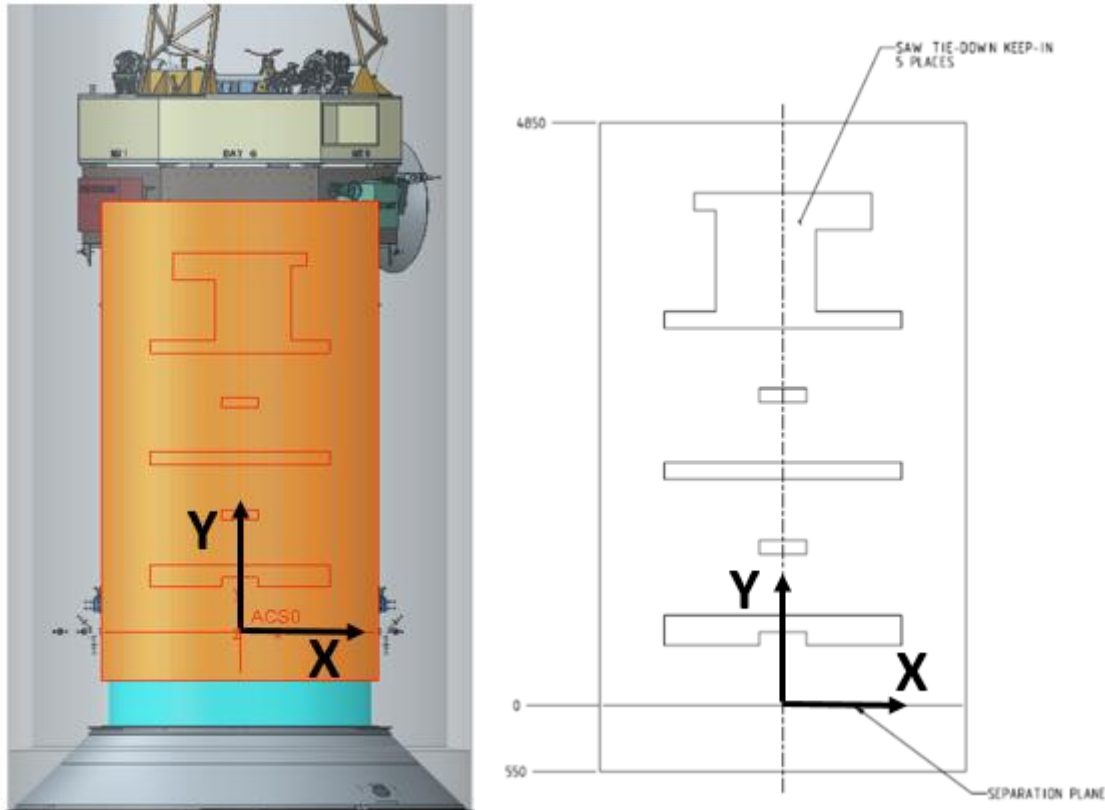


Figure 3b. Stowed SAW KIZ dimensions in mm.

by the ARM mission module structure. A preliminary drawing has been prepared showing the required KIZ configuration (orange colored volume, see Figure 3a) and dimensional constraints (see Figure 3b). To meet tight stowage volume requirements of the ARM SEPM application, SAW technologies tend to need specific volumes of about  $40 \text{ kW/m}^3$ , or about 3X better than state of the art SAWs. Even if a SAW technology exceeds  $40 \text{ kW/m}^3$  metric, it may not be stowable on the SEPM given the combination of KIZ dimensional constraints, tie down location constraints (discussed in the next section) and kinematic deployment trajectory constraints.

#### E. Stowed SAW Structural Interface

To meet launch acceleration loading and stowed fundamental frequency requirements, massive and large dimension SAWs require many (perhaps even 8 or more) structural tie downs per SAW. The tie downs provide a load path to safely react SAW inertial loads into the spacecraft primary structure without stress and displacement

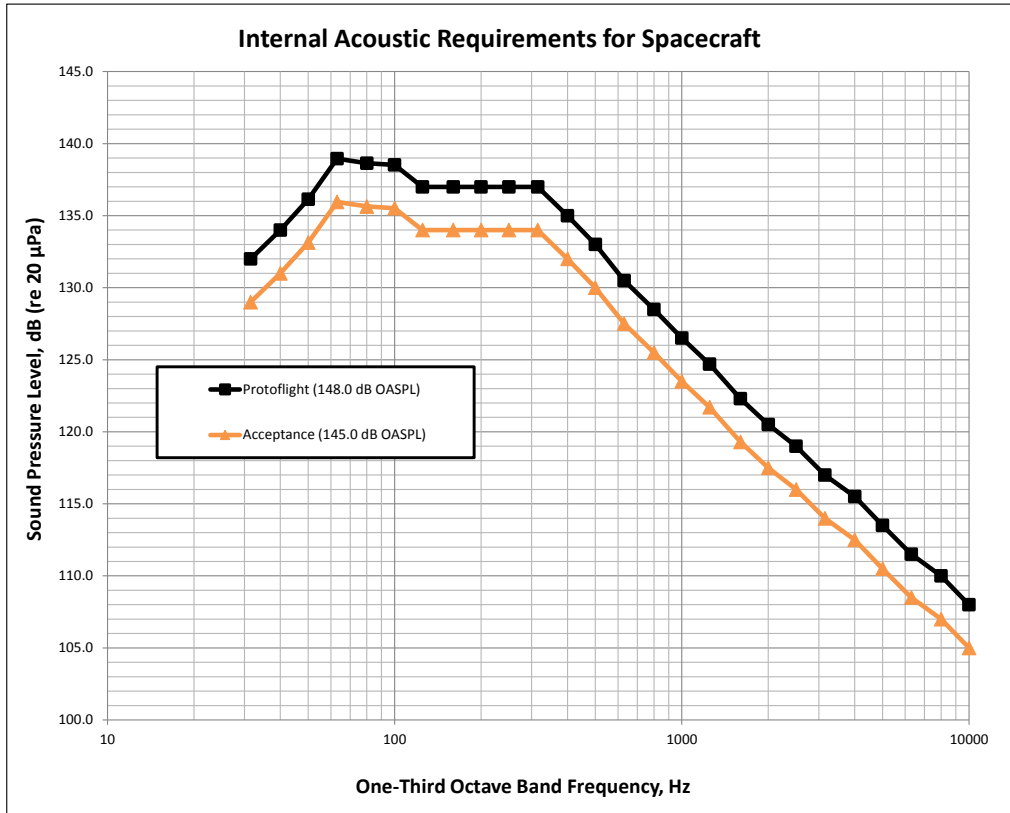


**Figure 4. Stowed SAW tie down structural interface keep in area for tie down attachments, dimensions in mm, +Z axis is out of the paper.**

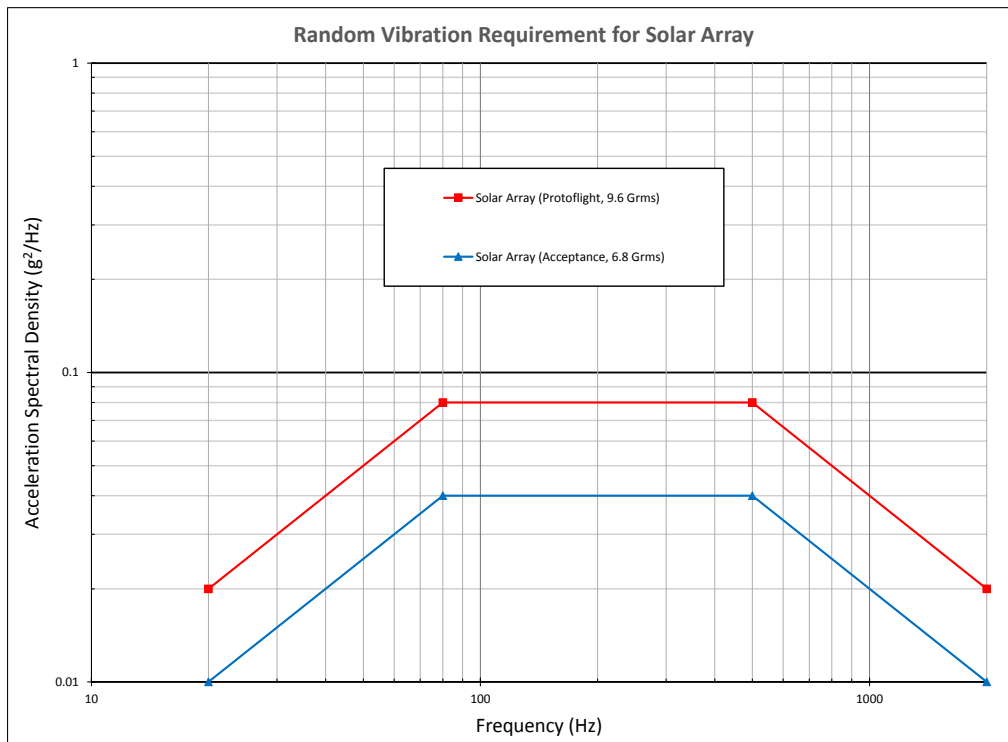
exceedances. Given the SAW technology has not been selected, ARM SEPM designers specified a generalized SAW tie down structural configuration using secondary structure. Several options for the secondary structure have been assessed, but all must have a gossamer configuration. This feature is required to minimize view factor blockage for the SEPM heat rejection radiator surface located below. The allowable area for SAW tie downs is shown in Figure 4. The SADA interface with the SAW offset boom, envisioned as a circular bolt plate with approximately 0.2 m outer diameter, is located on the stowed SAW KIZ inner plane surfaces allocated for SAW tie downs (Figure 3b) and along the dashed line in Figure 4 (exact location under study). Given the stowed SAW tie down locations will not be generally located in optimum locations, SAW structures may incur a mass penalty associated with stiffer cores, thicker facesheets and/or the need for greater localized panel reinforcements. The stowed SAW KIZ, in combination with the SADA interface attachment plus deployed SAW KIZ, discussed below, will drive stowed offset boom dimensions and overall SAW deployment kinematics to accomplish the needed articulations and trajectories to transition from stowed, to phased, to fully deployed SAW configuration.

#### **F. Others**

A detailed coupled loads analysis has not been performed to define stowed SAW loads during launch. Until that time, preliminary requirements will include an ascent quasistatic acceleration of 20 g, acoustic excitation as shown in Figure 5 and random vibration power spectral density levels as shown in Figure 6. The 20 g quasistatic acceleration includes the launch vehicle mass acceleration curve design load as multiplied by a 1.25 load uncertainty factor and 2.0 distributed load factor to account for the multi-meter span of a stowed SAW. These environments encompass those anticipated for state of the art heavy lift vehicles and for the SLS under development by NASA. On top of these environments and design factors, a SAW to SEPM interface load factor of 1.5 must be applied for the design of the SAW interface components such as tie down mechanisms and their associated panel fittings. Stowed SAW shock spectrums, maximum levels that the SAW must accommodate from spacecraft events and the maximum levels the SAW can produce during tie down release, have been assessed and defined. However, these shock levels are not expected to be SAW design drivers and hence are not discussed further.



**Figure 5. Ascent acoustic loading for stowed SAW.**



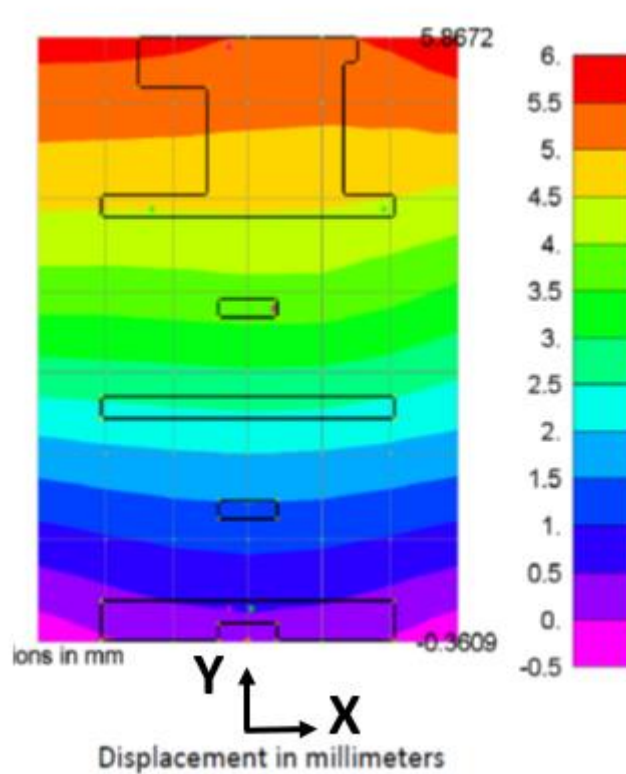
**Figure 6. Ascent random vibration loading levels.**

To avoid excessive coupling with ascent vibroacoustic loads, the stowed SAW fundamental frequency must exceed



25 Hz. This requirement would apply to dynamic modes with >10% mass participation and for those modes that drive local SAW stress levels. The additional assumption can be made that the SAW is mounted to an infinitely stiff spacecraft structure. It is expected that subsequent, system level structural dynamic assessments will be performed that include SEPM structure and SADA interface stiffnesses.

SAW tie down area (see Figure 4) enforced displacements, with respect to the SADA mechanical interface, have been calculated. Results show displacements of +0.8/-1.1 mm in the X direction, -0.7 to -2.6 mm in the Y direction and Z direction displacements are shown in Figure 7. The SEPM cylindrical bus structure is very stiff leading to



**Figure 7. Stowed +Z side SAW tie down enforced displacements relative to the SADA along the Z axis (+Z out of the page).**

relatively small displacements compared to that expected with more traditional spacecraft structural topology. The stowed SAW must be designed to either take up these displacements within the structure or implement tie down flexures or attachments configured to release the required displacement degrees of freedom. For large SAWs that cannot use kinematic attachments to the bus, the small displacements of this stiff SEPM structure become all the more important.

Some mission applications require strength for acceleration loading *during* SAW deployment prior to mechanism latching when the SAW may have reduced strength. As of now, the ARM vehicle will be in free drift mode during SAW deployment and does not have credible single fault scenarios resulting in vehicle acceleration (such as an inadvertent reaction control system (RCS) thruster firing). Thus, we foresee ARM SEPM SAWs will not be required to handle acceleration loading events during the brief period of SAW tie down release, phasing and deployment. This period is anticipated to be <20 minutes in total time.

In addition, the deploying SAW must not extend outside the stowed SAW KIZ XY plane in the Z direction towards the SEPM centerline as show in Figures 3a and 3b. High power SAWs can have >100 strings of solar cells that leads to a large power harness that must be managed to avoid entanglement during deployment. The large power harness also introduces proportionally larger deployment parasitic torques compared to conventional smaller SAWs.



#### IV. Deployed SAW Considerations

In this section, deployed SAW structural considerations are discussed. These items are under assessment and technical study in an effort to properly formulate technical specifications for the ARM SEPM advanced SAW.

##### A. Keep In Zone (KIZ)

To accomplish the ARM, a deployed SAW KIZ (see Figure 8) is required to ensure the spacecraft and SAW meet functional operation requirements. This KIZ includes 360° of SADA rotation and SAW displacements from

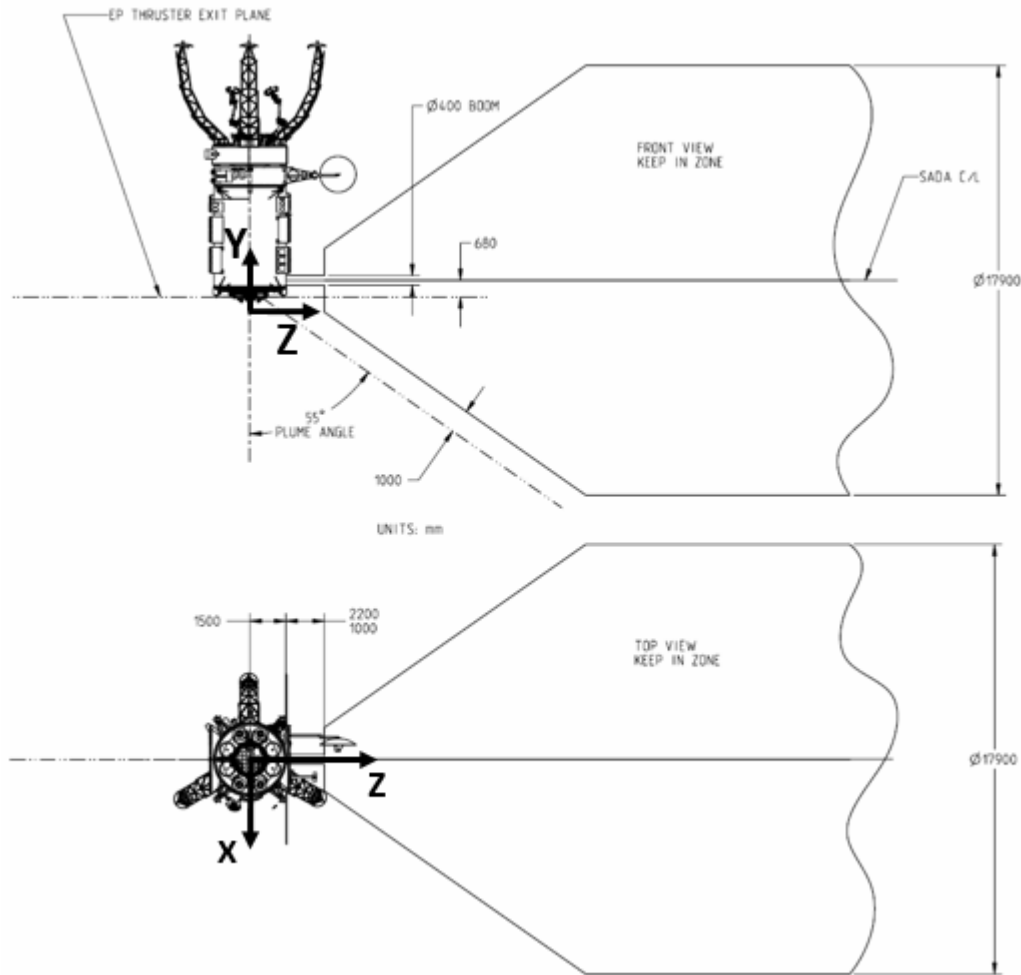


Figure 8. Deployed SAW KIZ, dimensions in mm.

thermal/structural loading requirements discussed below. The KIZ starts at the SADA structural interface plane and extends outward from the SEPM along the Z axis. The KIZ includes a 1-m separation margin against interference with SEPM, mission module and docking/docked Orion MPCV spacecraft surfaces and appendages, asteroid/boulder surfaces and avoiding the electric propulsion (EP) thruster plume keep out zone. The EP plume keep out zone is defined by a cone on the thruster centerline with a 55° cone angle (45° plume angle plus 10° thruster gimbal angle) and the cone apex at the thruster exit plane. KIZ defining surfaces also include: a 0.4 m diameter cylinder with length between 1.0 m and 2.2 m for offset boom accommodation with the intention of minimizing view factor to the radiator panels adjacent to and behind the SADA and a high gain antenna minimum separation of 1.0 m.

The KIZ was derived from numerous assessments including: (1) limiting xenon ion sputtering rates from the electric propulsion (EP) plume, (2) limiting thermal and structural loading from SEPM RCS chemical thruster plume impingement, (3) limiting the thermal control system (TCS) radiator to SAW view factor, (4) limiting thermal and structural loading from Orion RCS chemical thruster plume impingement during docking, (5) maintaining a safe

separation of the SAW with ARM and Orion spacecraft surfaces during dynamic docking load disturbances, (6) maintaining a safe separation of the SAW with the asteroid during near surface operation dynamic loading disturbances, (7) minimizing SADA bending loads during dynamic SAW load events, (8) minimizing deployed SAW moment of inertias, (9) minimizing line-of-sight blockage of communication antennas, star trackers and cameras, (10) alignment error stack up in actual flight hardware and (11) separation distance margins. Many of these assessments are discussed below in greater detail. Even if meeting the 55° cone angle to limit EP plume impingement, SAW composites may still suffer resin material thickness losses of about 25 μm requiring the use of an extra outer ply or a thicker outer ply to maintain structural allowables. Similar material thickness losses from EP plume ion sputtering could occur on flexible blanket mesh materials. As such, thicker flexible blanket mesh products will be required with their attendant penalties in packaging volume efficiency and mass.

Please note that the EP plume thrust level is so small (about 0.5 Newton (N)) that EP plume impingement results in negligible structural loading of a deployed SAW. However, the main EP plume should be avoided by deployed SAWs to limit unwanted disturbance momentum transfer to the spacecraft and to limit excessive xenon ion sputtering of SAW surfaces and the resulting molecular contamination produced.

### B. Moment of Inertial (MOI)

The deployed SAW MOI dominates the full spacecraft MOI and as such, will greatly impact the attitude control system (ACS) performance in terms of agility (attitude angular acceleration) and dead band. Therefore, a study was completed to evaluate and quantify MOIs for ARM spacecraft (ARV) for various SAW configurations, offset boom lengths, mission phases and spacecraft configurations to better understand the effect these different variables had on the overall vehicle MOI. Specifically, the relative MOI contributions for the SAWs as compared to overall vehicle MOI was evaluated. Two different SAW architectures, ATK-Orbital’s MegaFlex™ and Deployable Space Systems (DSS) Roll Out Solar Array (ROSA), were evaluated for the study. Two SAW orientations were evaluated, SAW photovoltaic (PV) surface edge on and normal to flight path. In addition, the impact that the spacecraft xenon propellant tankage mass and captured asteroid boulder mass/size (29 t, 3 m diameter class), had on the relative MOI

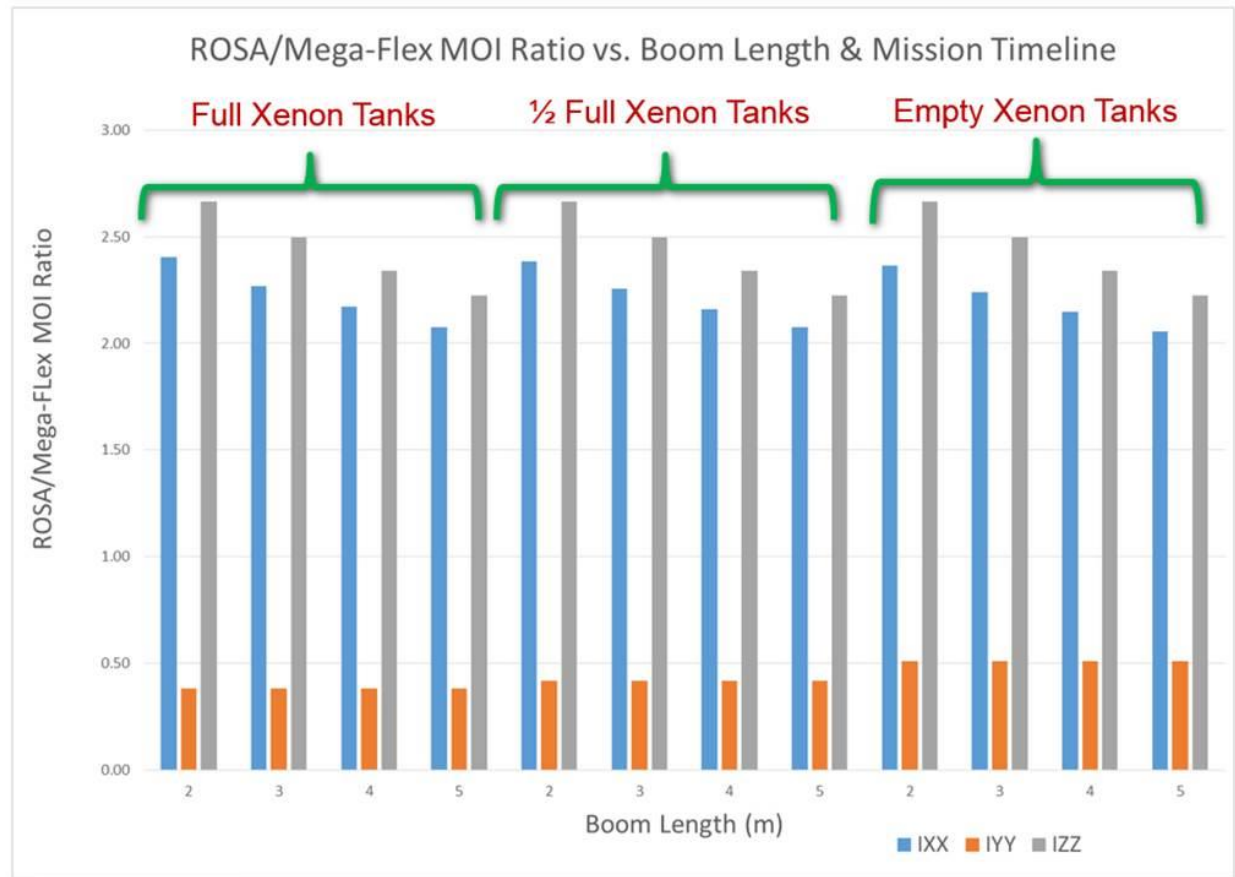
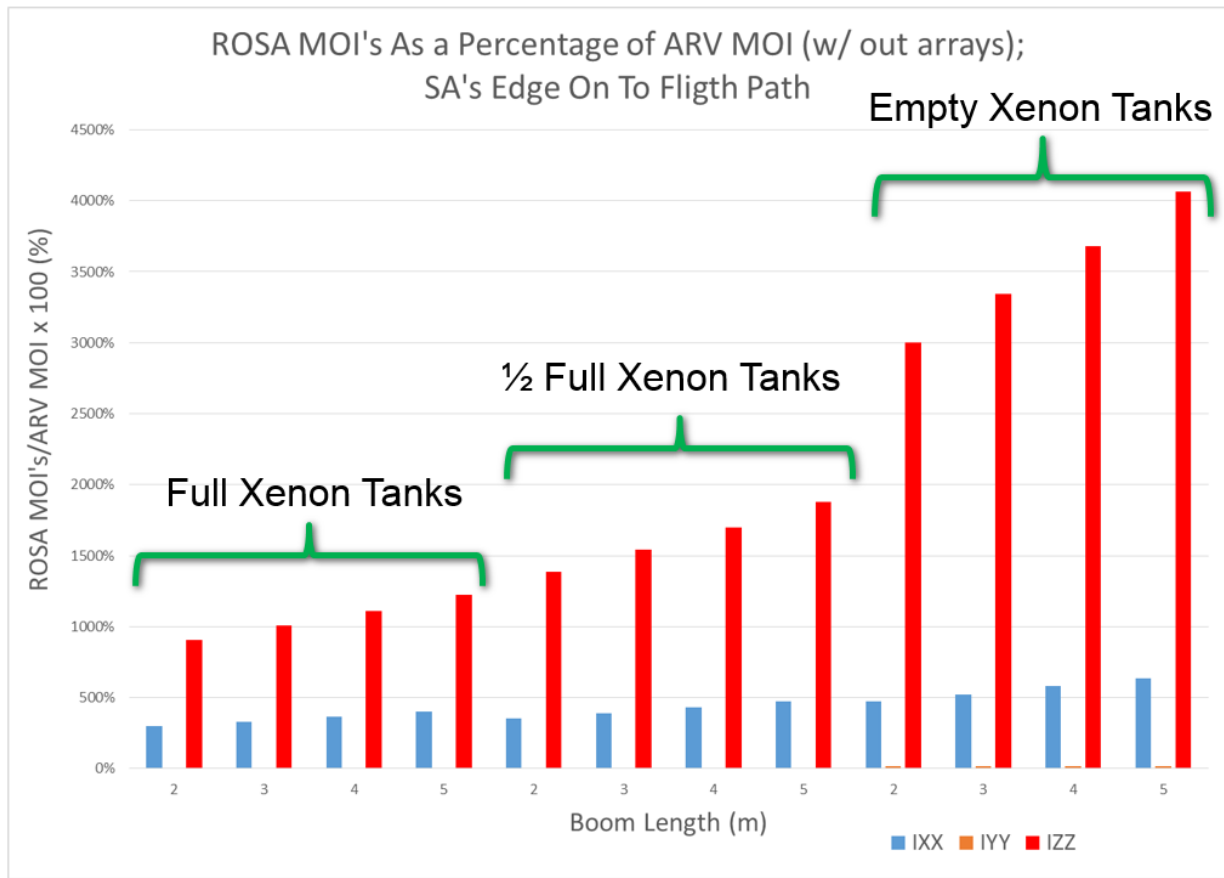


Figure 9. Ratio of ARV plus ROSA MOI divided by ARV plus MegaFlex™ MOI

contributions and center of gravity (CG) of the spacecraft was evaluated. Finally, the offset boom length for the SAW was varied between 2 m and 5 m (expected bounding lengths for mission) to better understand effect on overall vehicle MOIs. The MOIs were calculated based on both a finite element model (FEM) developed for the ARV bus (without SAWs) in addition to computer aided design (CAD) models developed for the two different SAW configurations and the various boom lengths evaluated. The coordinate system used for the MOI study was: Z axis-Flight direction (Roll Axis), Y axis-Pitch Axis and X axis-Yaw axis. Please note, this coordinate system is different than that defined in section III. All MOIs were calculated about the CG of the ARV (which changed depending on the variables being evaluated).

As shown in Figure 9, the DSS ROSA IXX and IZZ MOIs are much larger than those of a MegaFlex™ SAW due to the deployed SAW geometry differences. A MegaFlex™ SAW center of gravity is closer to the spacecraft allowing these MOIs to be smaller than a more traditional, slender rectangular shape SAW, such as the ROSA. As shown in

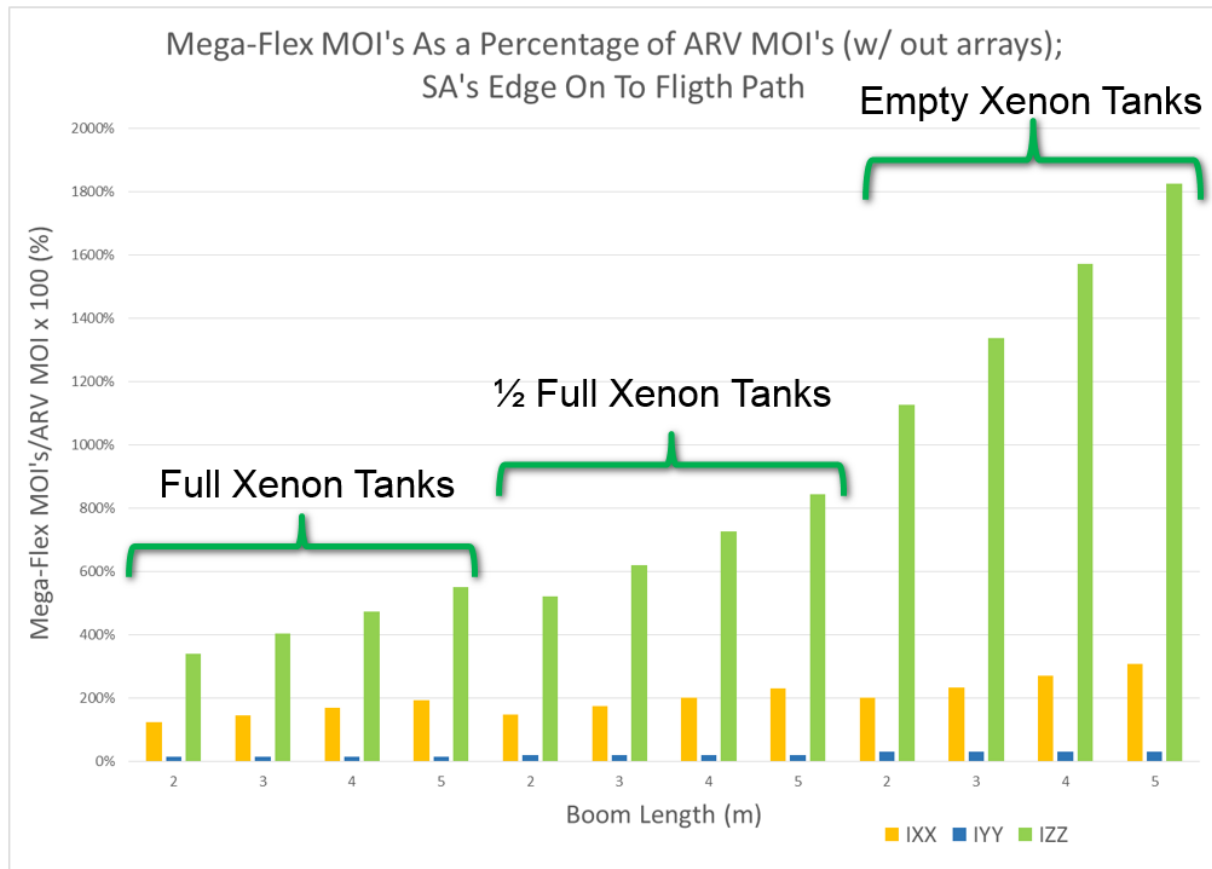


**Figure 10. Ratio (as a %) of ROSA MOI divided by the ARV MOI.**

Figure 9, the boom length did not significantly change the MOI ratios between the MegaFlex™ and ROSA. As shown in Figure 10, a more significant finding was the fact that the ROSA SAW MOIs dominated compared to the ARV (without SAWs) MOIs. Specifically, the ROSA IZZ MOI ranged from between 10–40X greater than the ARV IZZ MOI. The ROSA IXX MOI ranged from between 2–6X greater than the ARV IXX MOI. Similarly, but to a lesser extent, as shown in Figure 11, the MegaFlex™ IZZ MOI was quite a bit greater than the ARV IZZ MOI ranging from between 3–18X greater. Additionally, the study showed the SAW orientation (edge on versus normal to flight path) had a minimal effect on the relative MOI contributions of either SAW.

The effect xenon propellant loading fraction (full versus 1/2 full versus empty) had on the overall vehicle MOI was relatively insignificant as the SAWs were the most dominant contributor to the overall spacecraft MOI. The fact that the xenon propellant tanks are packaged close to the center line of the spacecraft was the reason that varying the propellant tankage level had such a minor impact on the overall spacecraft MOIs.

One final significant finding was the fact that even with the asteroid boulder mass included, the ROSA IZZ MOI still dominated compared to the IZZ MOI contribution from the ARV with the captured boulder. In addition, the CG shift of the entire spacecraft due to the asteroid mass was significant – a shift of approximately 4 meters, putting the



**Figure 11. Ratio (as a %) of MegaFlex™ MOI divided by the ARV MOI.**

CG much closer to the mission module end of the ARV, which would need to be taken into account when designing the ACS system.

### C. Deployed Loading – ARM RCS Plumes

The ARM spacecraft SEPM has an ACS that uses pods of 22 N monopropellant RCS thrusters to provide yaw-pitch-roll moment inputs. As shown in Figure 3a, these thruster pods (shown in royal blue color) are mounted on struts (shown in yellow color) attached to the SEPM. Some of these thrusters are directed at the deployed SAWs so that plume impingement will result. As a limiting design case, the ARM deployed SAWs must demonstrate positive margins of safety for the loading cases including the 22 N RCS thruster plume impingement force applied at any point on the SAW and with any line of action. The SAW must be designed to handle the plume forces as quasisteady (as would be the case for a translational ARV maneuver) and dynamically, at the rate of 5 Hz for a sequence of ten 100-millisecond on/off pulses. The SAW must be designed for RCS thruster plume loading on top of deployed SAW load cases associated with asteroid proximity operations. RCS thruster plume loading need not be applied to Orion approach and docking operations since Orion will be the active vehicle and the ARM spacecraft will be in free drift. In addition, SAW structures must demonstrate positive margins of safety including RCS plume impingement heating of 341 W/m<sup>2</sup>. This heating level causes about a 40°C temperature rise in thin wall composite structures at typical initial operating temperatures and is expected to result in some loss in material allowables.

### D. Deployed Loading – Asteroid Near Surface Operations

ARM vehicle near-surface asteroid operations include the follow dynamic loading cases for the deployed SAWs: descent touch down impact, asteroid boulder extraction, and ascent acceleration. The dynamic load cases have been

analyzed and have been shown to be encompassed by the equivalent of a 0.03 g quasisteady acceleration. As such, asteroid near surface operational load cases are not design driving for the deployed SAW acceleration requirement.

#### E. Deployed Loading – Orion RCS Plumes

Deployed SAW strength loading cases analyzed also include thruster plume impingement loads during Orion docking approach. The scenarios of greatest concern for SEPM SAW plume loading would be firing of the Orion

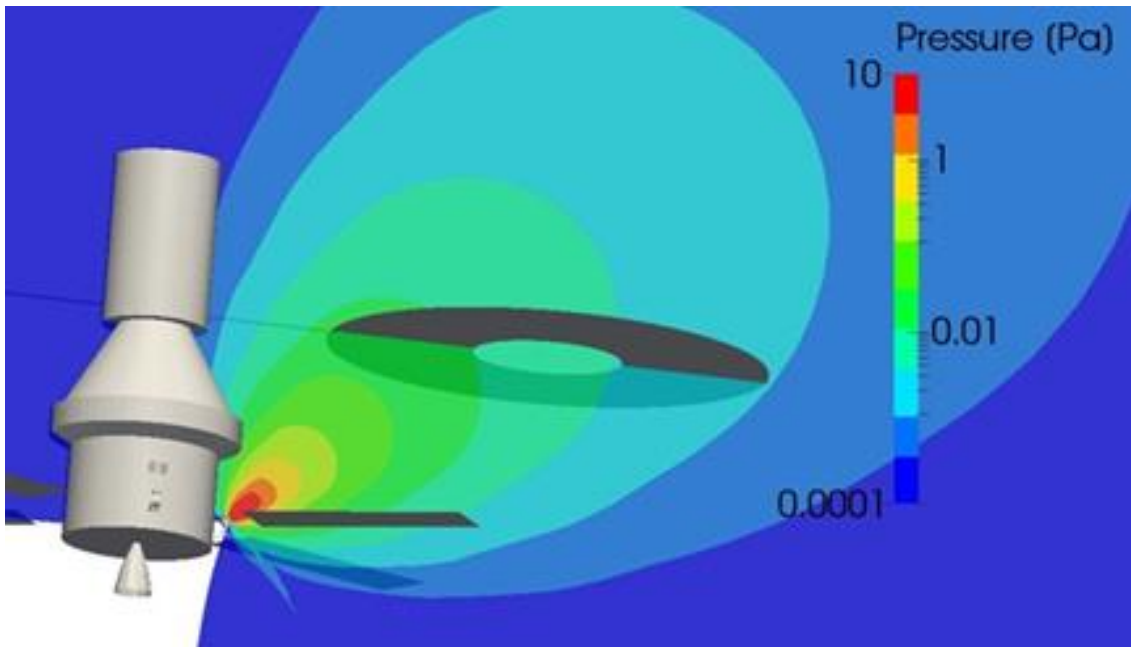


Figure 12. Sample Orion forward RCS thruster plume pressure flow field relative to vehicle geometries.

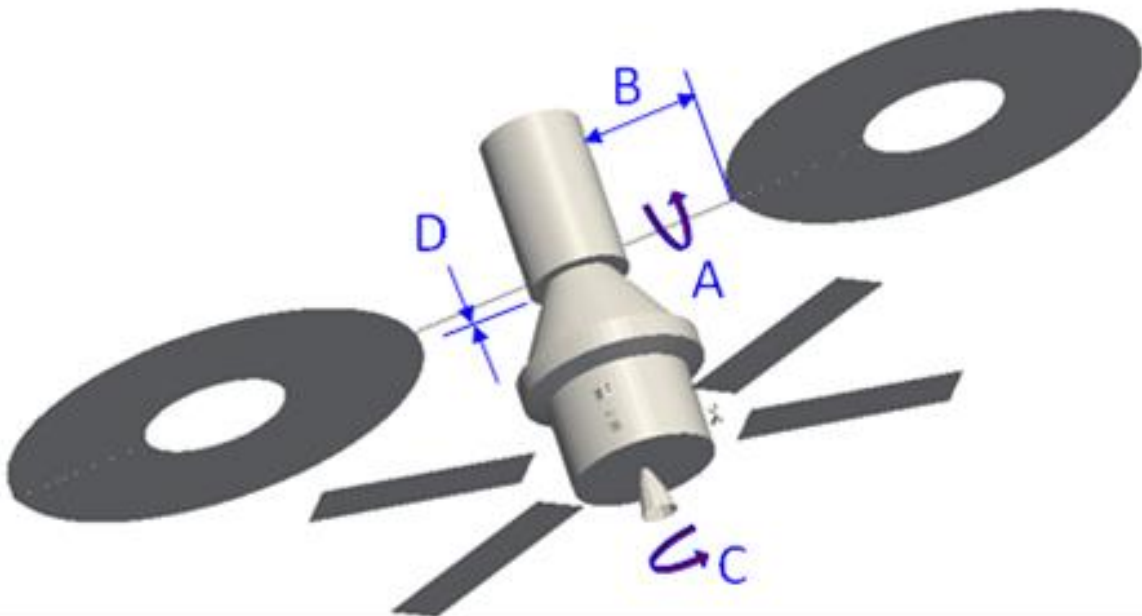
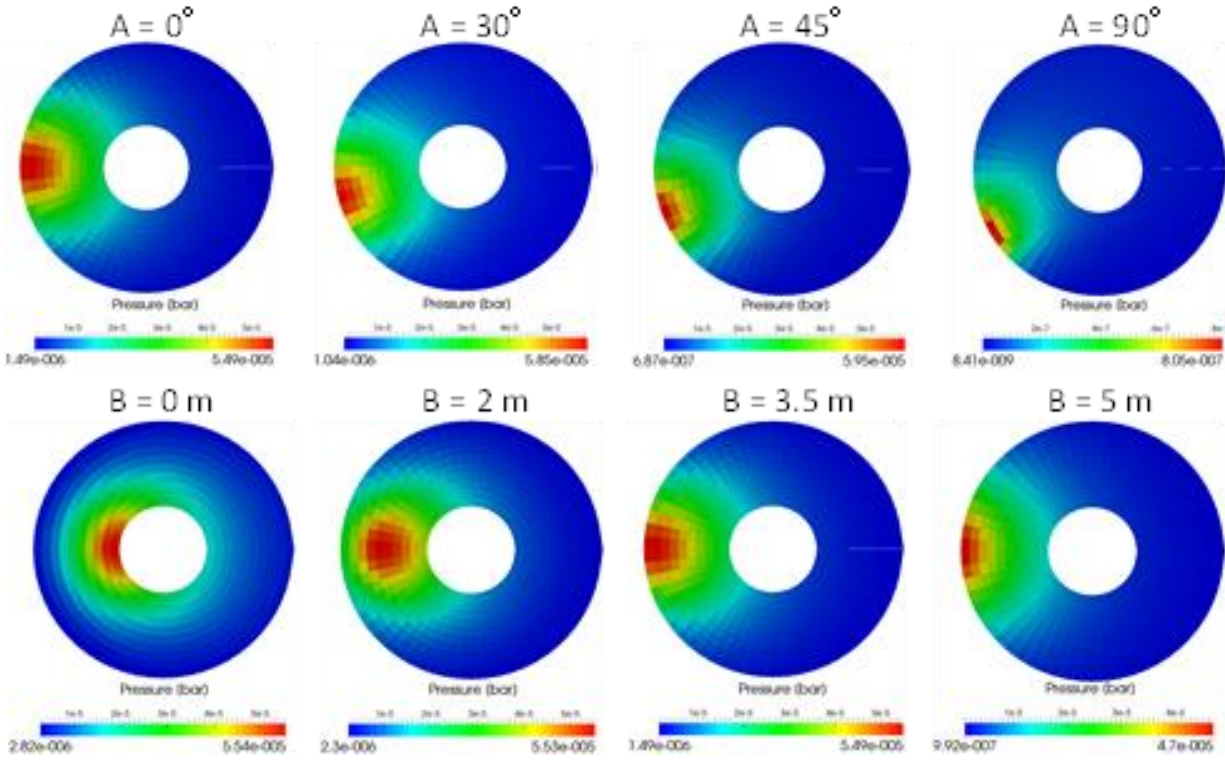


Figure 13. Orion plume loading geometric parameters.

forward facing RCS thrusters that would occur during an emergency break-out maneuver for aborting a missed docking attempt. The plumes from these 220 N bi-propellant RCS thrusters were previously modeled for self-

impingement studies on the Orion vehicle<sup>3</sup> and the analysis is extended here for impingement to the SEPM SAWs. In particular, the Reacting And Multi-Phase (RAMP2) and PLume IMPingement (PLIMP) codes are used here for this initial assessment and further details on the general analysis approach, assumptions and methods can be found elsewhere<sup>3</sup>. A sample output of the plume pressure flow field from RAMP2 is shown in Figure 12 relative to a sample



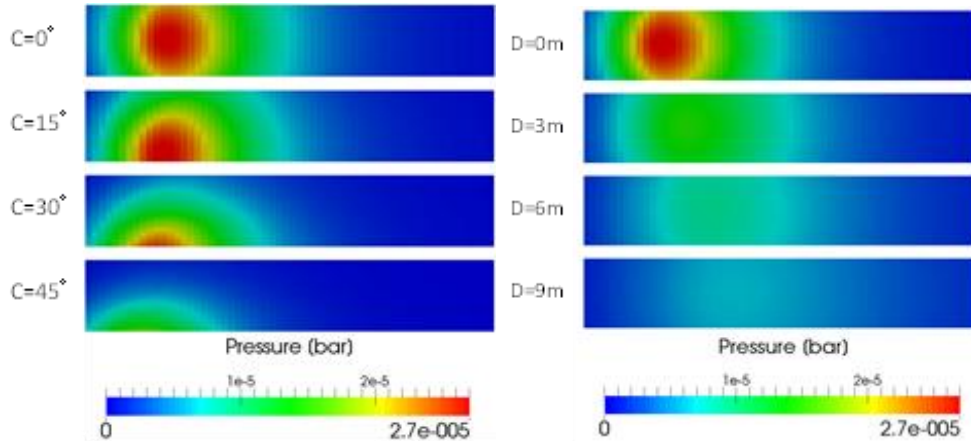
**Figure 14. Pressure profile on a circular SAW with variation of SAW rotation angle and boom length.**

docked Orion and SEPM configuration.

A parametric study was carried out to evaluate the expected plume impingement loads on the SAWs, including quasistatic acceleration loads as well as bending moments relative to the vehicle body and torsional moments about the SAW axes. Both the circular and the rectangular SAW geometries were evaluated. Several geometric variables, diagrammed in Figure 13, were assessed including: (A) angle of SAW about boom axis ( $0^\circ$  shown), (B) boom offset distance between SEPM and SAW (3.5 m shown), (C) clocking angle of Orion with respect to the SEPM docking adaptor ( $0^\circ$  shown), and (D) distance of separation between Orion and the SEPM (0 m shown). Sample impingement loading results are shown in Figure 14 with the change in pressure profiles on a circular SAW due to changes to the rotation angle of the SAW about the boom axis (top) and with the boom offset distance (bottom). Figure 15 provides example pressure loading profiles on a rectangular SAW geometry with variation of the docking clock angle (left) and inter-vehicle distance (right). For both figures, the main vehicle body of both Orion and the SEPM is to the left.

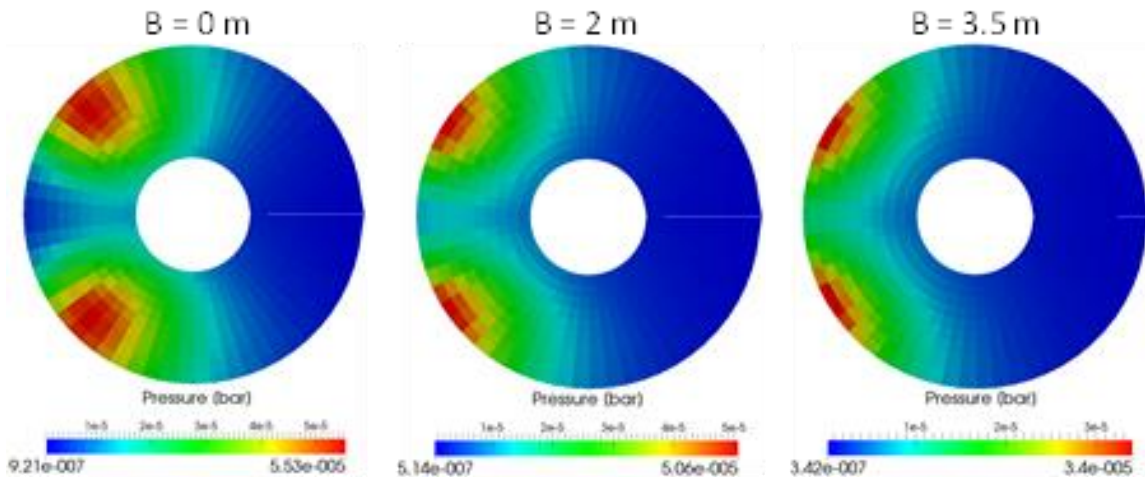


Multi-thruster plume effects were also assessed. The RAMP2/PLIMP codes do not calculate true plume interactions, but as a first-order estimate, a simple superposition of multiple plumes was used. The Orion RCS thrusters are organized into two redundant strings with nearly identical layout of thrusters spaced at  $90^\circ$  intervals around the Orion Service Module outer radius. However, only a single string is planned for nominal operation, thus any two



**Figure 15. Pressure profile on a rectangular SAW with variation of docking clock angle and separation distance between Orion and the SEPM.**

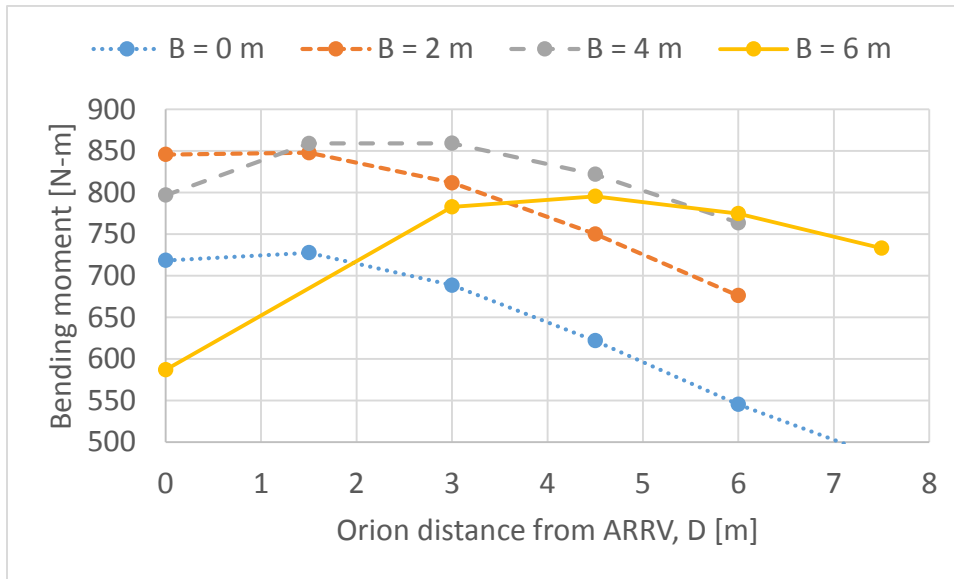
operating forward facing RCS thrusters will be a quarter turn of the vehicle apart. A clocking angle of  $45^\circ$  for docking, then, could position a SAW to encounter two thruster plumes simultaneously depending on planned thruster operation for docking maneuvers. Sample pressure profiles for this scenario are shown in Figure 16 along with the effect of varying the boom length. It should be noted that there are also a set of roll control thrusters located in RCS pods closer



**Figure 16. Pressure profile on a circular SAW for multiple thruster plume impingement at a  $45^\circ$  clocking angle with variation of boom length.**

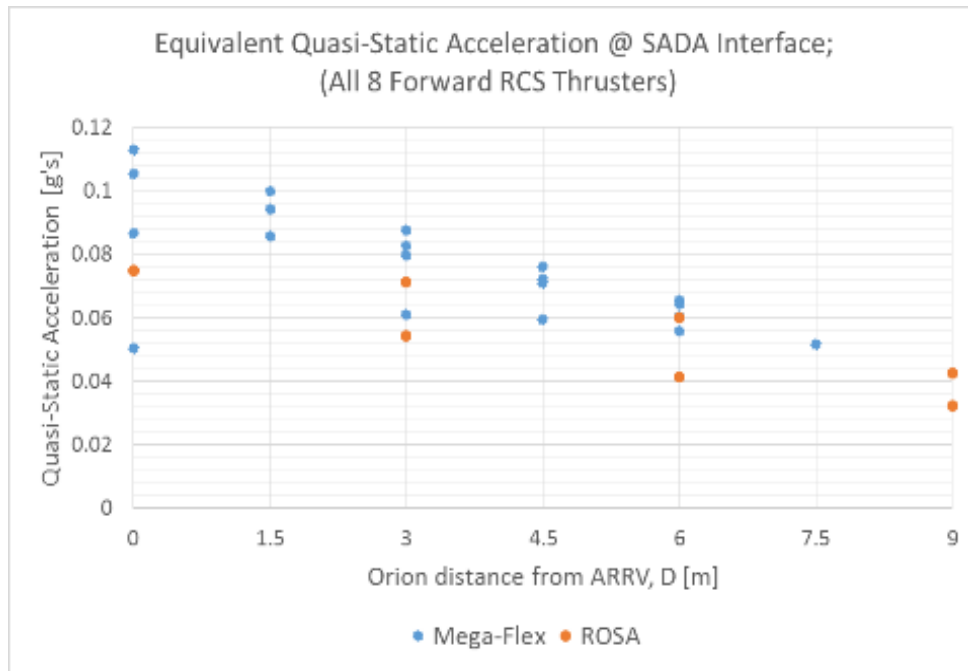
to the Crew Module end of the Orion Service Module than the forward facing yaw/pitch RCS thrusters shown thus far. However, the orientation of these thrusters (pointed tangentially to service module cylindrical surface) do not lead to as much plume impingement on the SEPM SAWs. Even in the worst-case scenario where the SAWs are rotated  $90^\circ$  about their boom axis to provide the greatest view factor to the roll control thrusters, the resulting plume impingement effects are still a couple orders of magnitude lower than seen for the forward facing thruster plumes.





**Figure 17. Bending moment as a function of the boom length and inter-vehicle distance for the circular array SAW geometry.**

Each of the input parameters were varied to estimate the worst-case loads. The bending moment of the SAW relative to the SEPM main vehicle body will be a function of the total plume impingement force across the SAW surface and the location of the center of pressure. Some geometric parameters will have competing effects on the



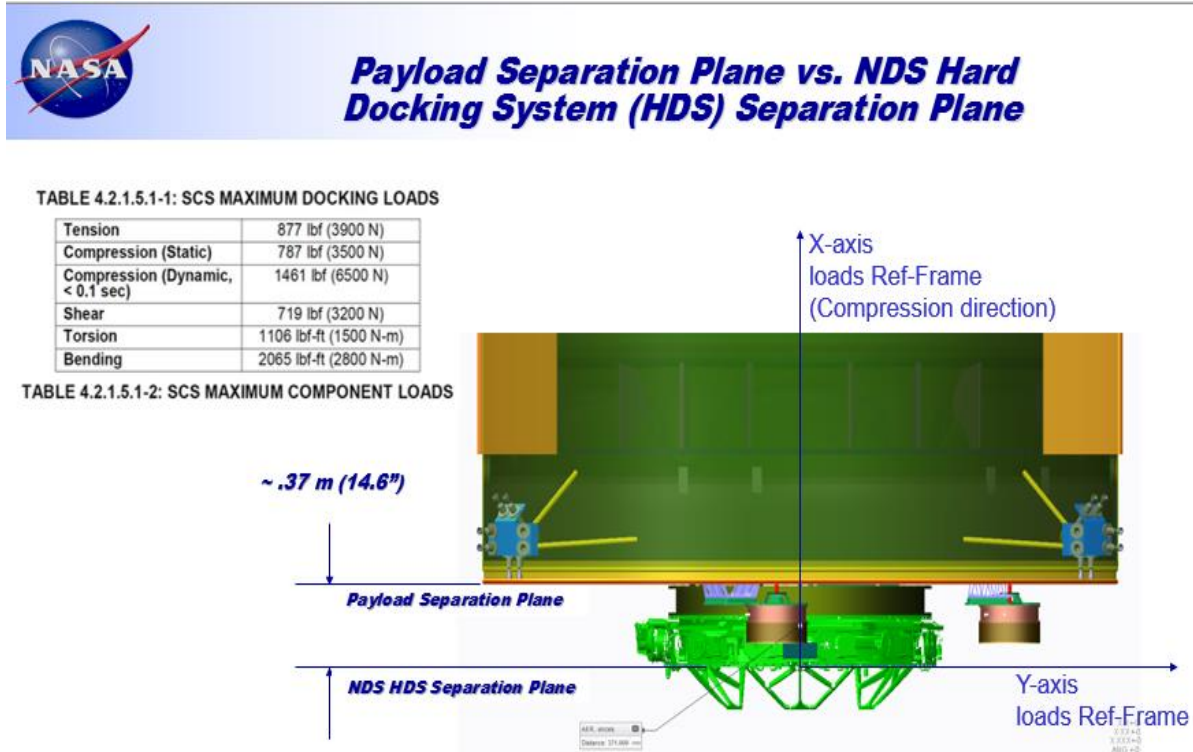
**Figure 18. Orion plume impingement quasistatic acceleration loading.**

bending moment as they may increase the moment arm but reduce the total force or vice versa. A sample of some bending moment outputs is shown in Figure 17 for the circular SAW. Here it is seen that the separation distance between the vehicles that cause the maximum bending moment will vary with the boom length. All cases examined, however, showed the bending moments to remain below 900 N-m for the circular SAWs while the bending moments for the rectangular SAWs were found to remain below 700 N-m. This range of bending moment is perhaps 10X greater than experienced in state of the art SAWs. The torsional moments about the boom axis for the SAWs was

found to vary the most with clocking angle of the two vehicles for docking, since that effectively moves the center of pressure further off the boom axis. The maximum torsional moment was found to be around a clocking angle of 30° for both SAW types. The circular SAW was found to have torsional moments nearing 350 N-m while the rectangular SAW was much lower, below 30 N-m, due to its small width about the boom axis. The quasisteady acceleration was also calculated and found to be on the order of 0.1 g for the worst-case geometry configurations as shown in Figure 18.

**F. Deployed Loading – Orion Docking**

The Orion MPCV will dock with the ARM SEPM –X axis end, near the EP thrusters, via the International Docking System (IDS)<sup>4</sup>, formerly known as the NASA Docking System (NDS)<sup>5</sup>. The IDS is shown in Figure 19 mounted to the SEPM. Please note that the docking loads assessment coordinate system is different from those in Sections III and



IVb. In this section, the X axis is along the SEPM longitudinal axis, the SAWs are mounted along the Y axis and the Y-Z plane is aligned with the IDS separation plane. Refer to Figure 13 for a conceptual view of the Orion MPCV docked to the ARM SEPM. The docking event produces dynamic loads and moments in the IDS that are translated through the SEPM to the base of the SAWs. The worst case SEPM docking port impact was simulated by applying the maximum load and moment values (per Table 3.3.1.4 in reference 4 and shown in Figure 19) as a single, 0.5 second long step pulse.

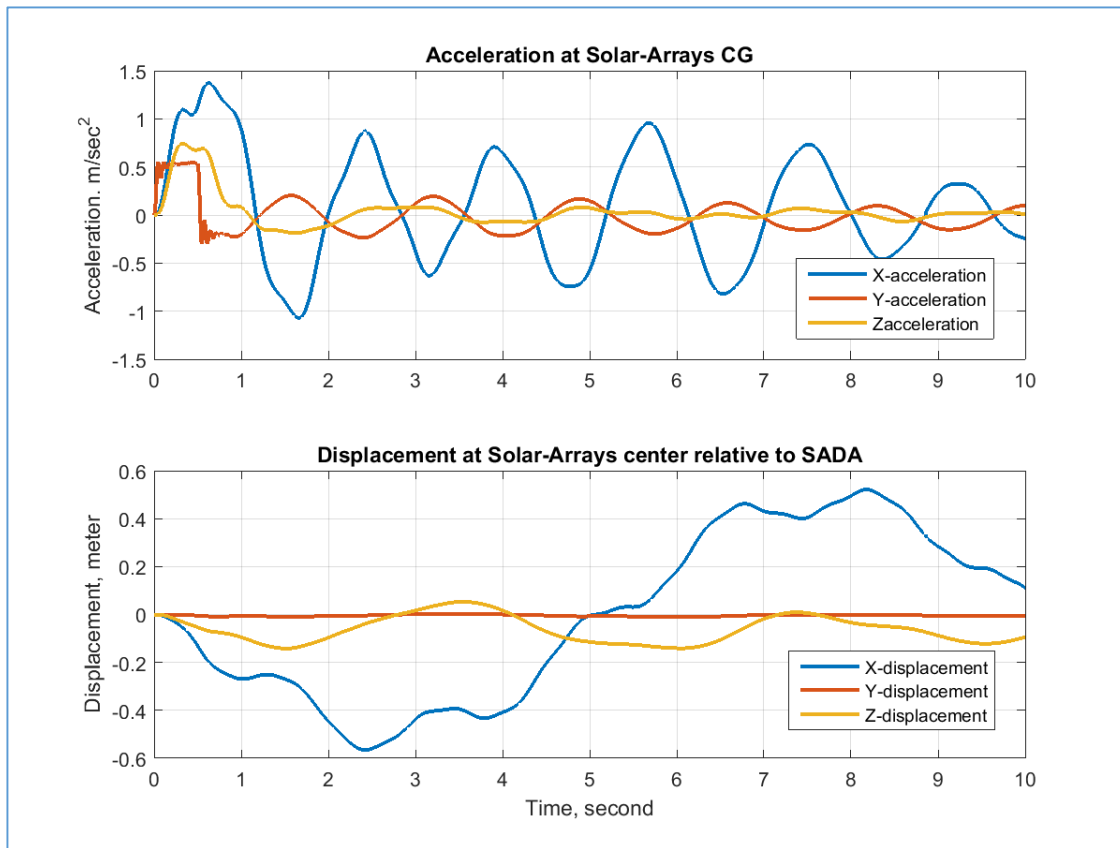
Using a multibody dynamics (MBD) analysis approach, the maximum dynamic loads on the SAWs and their structural response interacting with the ARV main body were predicted. The ARV was modeled as a rigid body with CG mass and inertia values including the ARV dry mass, 8 t of Xenon propellant and assuming no captured boulder mass. The Xenon is assumed to be in a supercritical state such that propellant dynamic sloshing effects can be ignored. IDS docking port was modeled with suitable stiffness and damping properties associated with its soft capture system (SCS). Simulations also used suitable assumptions for SADA stiffness, a rigid offset boom and 1% damping. The offset boom to SAW attachment is made using a root hinge with modeled shear stiffness of 13.9 N/mm and bending stiffness of 1300 N-m/°. The modeled offset boom length is 4 m and the SAW type assumed was MegaFlex™. A typical value of 1% modal damping is assumed for all SAW dynamic modes. The mass of each SAW, excluding the offset boom and SADA, is assumed to be 196 kg. Linear and angular accelerations at the SADA-offset boom interface plane for this model are generated by the MBD model which includes the ARV, the docking port and the two SAWs.

Conversely, linear and angular momentum of SAW motion relative to the SADA are computed, using the Newton-Euler approach, to model the effective forces and moments of boom whiplash affecting rigid body SAW modes.

The respective MOI of the starboard and portside SAWs, given in the individual Structural Reference (SR) coordinate frame are given in Eq. (1):

$$I_{starboard} = \begin{bmatrix} 1229.5 & -3.0 & 110.8 \\ -3.0 & 2086.3 & 0.1 \\ 110.8 & 0.1 & 3261.5 \end{bmatrix} Kgm^2 ; \quad I_{port} = \begin{bmatrix} 1229.5 & +3.0 & 110.8 \\ +3.0 & 2086.3 & -0.1 \\ 110.8 & -0.1 & 3261.5 \end{bmatrix} Kgm^2 \quad (1)$$

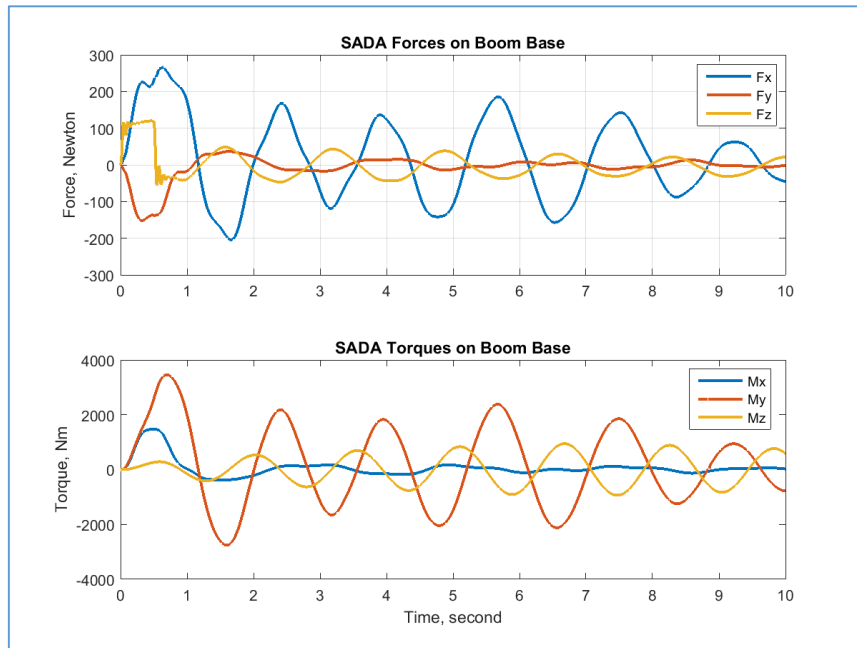
The SR coordinate system has the x-axis pointing inwards along the offset boom towards SADA and the z-axis pointing upward from the SAW solar cell surface. The off-diagonal entries in the MOI matrices (given in the respective local SR frame of each SAW) that correspond to  $I_{xy}$ ,  $I_{yz}$ ,  $I_{yx}$  and  $I_{zy}$  switch sign, starboard versus portside. This is



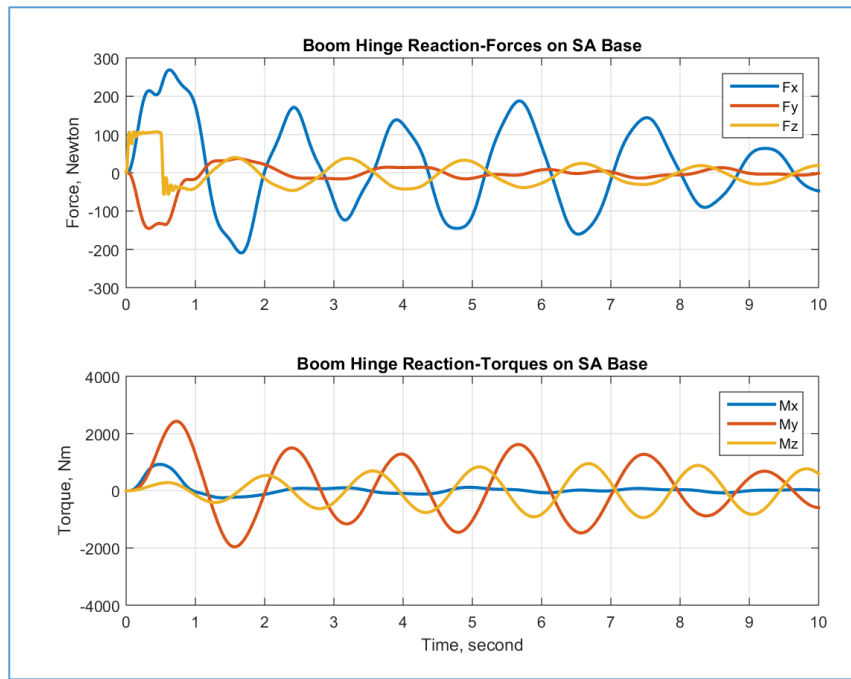
**Figure 20a. Orion docking transient starboard SAW linear acceleration and linear displacement at SAW center of mass, given in ARV body frame (B-frame) coordinates (with the X-axis pointing forwards and the Y-axis to starboard).**

due to mass distribution reflection symmetry of the two SAWs to one another across the y-z plane, while the z-axis of the two local SR frames are pointing in the same direction.

These simulation results showed that, quasisteady accelerations at SAW center of mass (CM) under worst case IDS docking impact are below 0.1g. However, peak acceleration is about 0.153 g (or nearly 1.5 m/sec<sup>2</sup>) as shown in Figure 20a. These acceleration levels are about 20X higher than for state of the art SAWs. The resulting reaction forces and moments at the SADA – offset boom interface for the starboard SAW are shown in Figure 20b. Similar results would be predicted for the port SAW. As expected, offset boom-SAW root hinge interface reaction torques are lower than the SADA torques (comparing lower plots of Figures 20c and 20b). On the contrary, due to boom whiplash motion, linear accelerations at the boom tip are higher than at the base (comparing upper plots of Figures 20d and 20a).

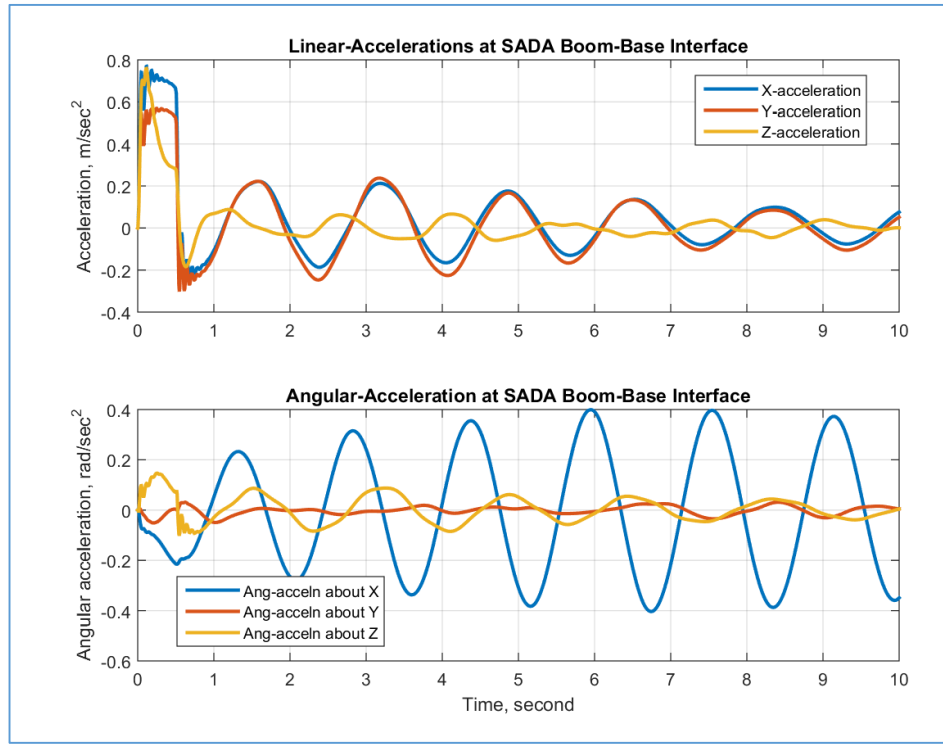


**Figure 20b. Orion docking transient forces and moments of the starboard SADA at the SAW offset boom base, given in ARV B-frame coordinates.**



**Figure 20c. Orion docking transient reaction forces and moments of the starboard SADA at the SAW offset boom base, given in ARV B-Frame coordinates.**

The dominant 0.5 Hz response frequency shown is of rigid body rotations of the SAW about the offset boom – SAW interface. This frequency was found to be greatly dependent on the prescribed shear and bending stiffness of the offset boom – SAW root hinge. These shear stiffness and bending stiffness values in this simulation were chosen to be comparable to that of boom bending stiffness.



**Figure 20d. Orion docking transient starboard SADA - boom interface linear acceleration (upper plot) and angular acceleration (lower plot), in ARV B-Frame coordinates.**

From the MBD modeling results, the lowest boom bending frequency under SAW inertial loading is about 0.1 Hz for 4 m boom length. This mode is one among the simulated 10 boom bending modes modeled as stiffly constrained at boom base as part of a companion study. Inertial loads including centrifugal loads on the SAW due to linear and angular accelerations at the SADA-offset boom interface are applied to the SAW to simulate its response to docking impact loads. It is desirable to have the natural-frequencies of SAW rigid body motions relative to SADA mount-structures higher than 0.5 Hz to attain good separation between these modes and the flex modes of the SAW and the boom. Note that, the lowest-frequency flex mode (in-plane modes) of the 196 kg SAW analyzed is about 0.1 Hz. Hence, dynamic interactions of the SAW with the main body and SADA mount structure below 0.5 Hz could potentially cause structural instabilities in the SAW or result in vehicle attitude instabilities during docking or undocking. These interactions will need further parametric studies to fully understand. This will require both frequency domain analyses and time-domain simulation with sufficient fidelity that should include modeling the effects of RCS thruster plumes on the SAW and SAW blanket flex dynamics. In addition, NASA does plan to evaluate the effect of structural and flexible blanket damping levels on the dynamic response and loading of SAWs, offset booms, SADA and the overall spacecraft dynamics control during transient loading events such as docking.

### G. Deployed Stiffness – SAW Flex Body Frequency

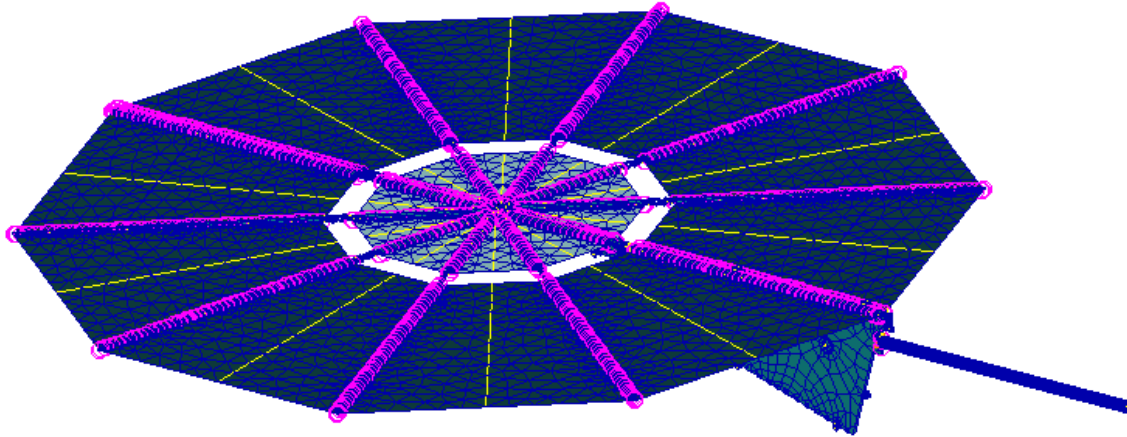
Deployed planar SAWs typically have the first three modal shapes associated with out of plane bending, in plane bending and torsion – although the order of these first 3 modes may switch depending on the exact SAW configuration/design. The SEPM deployed SAW dynamic modes with > 10% mass participation must exceed 0.1 Hz when mounted to an infinitely stiff spacecraft sidewall. Likewise, to allow for a reasonable decay of SAW dynamics and to limit dynamic over shoot, a SAW damping coefficient of >0.01-0.02 is required. This damping value is thought to provide adequate control band separation between SAW deployed modal frequencies and the spacecraft ACS bandwidth so that controls-structures-interactions (CSI) are minimized to acceptable levels.

The bending and torsional stiffness, damping and backlash of the SADA as well as the stiffness of the SAW offset boom all have to be taken into account when evaluating the overall system level structural dynamics, response and interaction of the deployed SAW with the spacecraft. Figure 21 shows a FEM developed to evaluate the impact that the offset boom stiffness has on the overall deployed frequency of the SAW (12.5 m diameter MegaFlex™ SAW



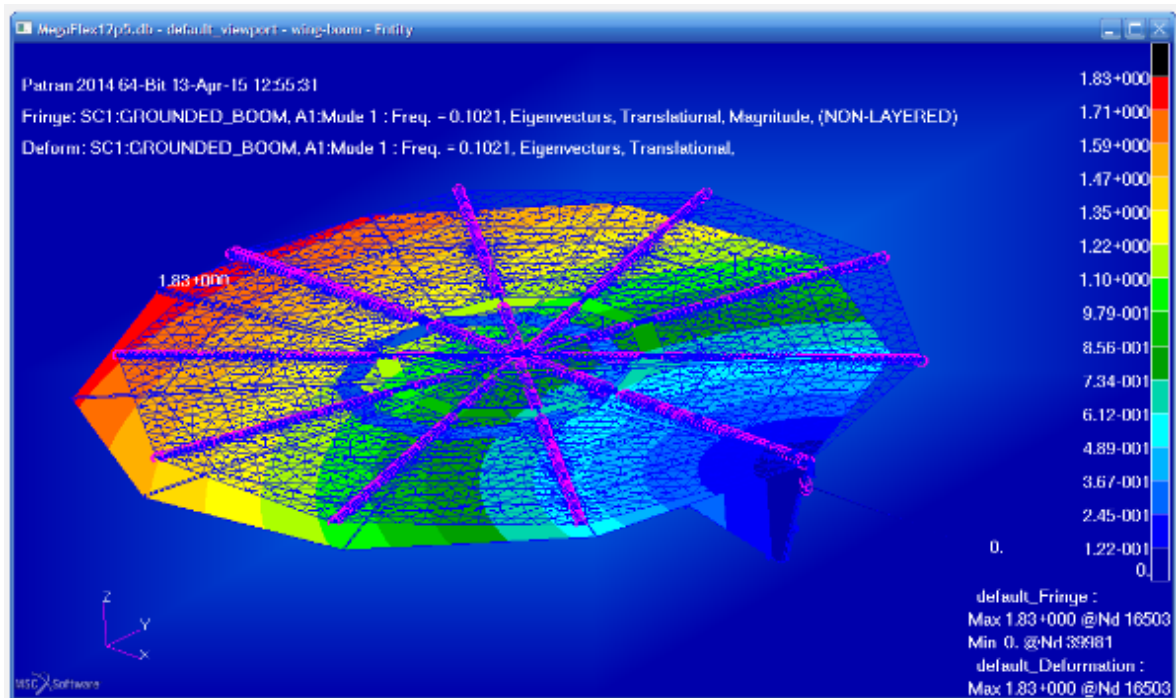
shown) assembly. Figure 22 shows the deployed frequency results with an integrated 153 mm outer diameter (OD) x 1.27 mm thick x 4 m long composite offset boom.

The results of early parametric studies have shown that even for a relatively long and slender composite boom (with quasi-isotropic properties) the effect the boom had on the overall stiffness/frequency (1st Mode – In-Plane “Buzz



**Figure 21. Parametric MegaFlex™ SAW with offset boom FEM.**

Saw” Mode) of the integrated SAW assembly was small, a drop in frequency of ~ 10% (0.10 Hz with offset boom versus 0.11 Hz without offset boom). Likewise, the addition of the 4 m long offset boom had little impact on the 2nd



**Figure 22. Deployed frequency of MegaFlex™ and offset boom.**

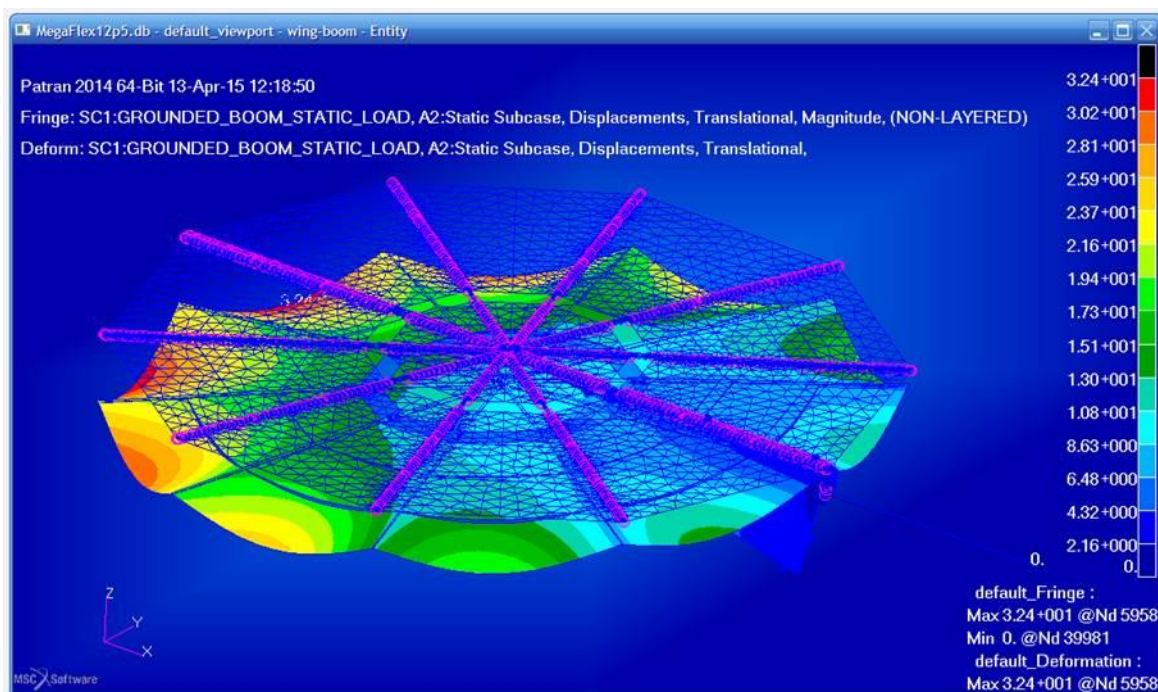
SAW mode (torsion), 0.206 Hz versus 0.210 Hz. The 3rd mode of the integrated SAW/offset boom (Out of Plane Bending “Diving Board” Mode) was the most sensitive to the addition of the offset boom dropping the lateral bending

frequency from 0.29 Hz to 0.24 Hz. However, this 3rd mode is not of primary concern and it is well above the 0.1 Hz requirement for SAW.

Another aspect that needs to be considered as it pertains to the deployed stiffness of the SAW and dynamic response of the SAW is the torsional stiffness and damping of the SADA. Although it is expected that the torsional frequency of the SAW should easily meet the 0.1 Hz frequency requirement and thus provide enough separation to avoid CSI with the SADA motor controller, the stiffness and damping of the SADA still needs to be considered when evaluating the system level dynamic response. The reference SADA architecture that has been selected for the ARM mission is a slip-ring style SADA. Typically, torsional stiffness for a slip-ring style SADA is achieved through the stepper motor drive and the appropriate/required gear reduction which has traditionally been sufficient in the past to minimize disturbances back to the spacecraft with traditional rigid flat panel SAWs. As the SAWs become larger and larger the overall torsional stiffness of the integrated SAW and SADA assembly will have to be evaluated more closely to make sure the levels of disturbance being transmitted back to the spacecraft are acceptable. Likewise, the damping of the SADA has to be taken into account when estimating the overall dynamic response of the integrated SAW and SADA assembly. Traditionally, a specific SADA damping level is not specified or formally required for typical geosynchronous sun-tracking applications with rigid panel SAWs. The friction that is inherent in a slip-ring style SADA has been enough to enable and maintain stable stepping of the SADA motors to drive the SAWs. However, further modeling and analysis should be completed to better understand the effect SADA stiffness and damping will have on the overall spacecraft ACS.

### H. Deployed Stiffness – SAW Displacement

During dynamic disturbances, the deployed SAW must limit its tip displacement to avoid damaging contact with other surfaces and stay within the defined deployed SAW KIZ. Two operational cases are of chief concern: (1) Orion docking with the ARV and (2) ARV descent to, landing on and ascent from the asteroid. In operational case (1), ARV SEPM SAW contact with Orion vehicle surfaces must be avoided. Figure 23 illustrates MegaFlex™ SAW displacement under 0.1 g out of plane steady acceleration. The maximum displacement for the SAW outer gores is about 0.81 m for this case which is quite acceptable.



**Figure 23. Displacement (shown in inches) of MegaFlex™ SAW under 0.1 g, out of plane Z-axis**

In operational case (2), ARV SEPM SAWs must avoid contact with the captured boulder as well as the asteroid surface. The asteroid surface will have local slopes, boulders and local terrain asperities that will be specified, but likely not known accurately a priori, to guide the spacecraft design. Instead, landing site attributes will be measured in real time during the mission and landing sites selected on the basis of meeting many predefined criteria for safe spacecraft operations and surface boulder extraction probability of success. If NASA elects to use the selected ARM



SAW design or technology for other mission applications, the deployed SAW KIZ may not be defined. In this case, the maximum deployed SAW displacement must be limited to reasonable value. One chief example is the International Space Station (ISS) power augmentation application in which the new technology SAW could be mounted closely in front of the existing ISS SAW. Thus, contact between the 2 SAWs must be avoided to manage ISS and crew safety risks and loss of channel power. For this application, the deployed SAW maximum displacement must be kept <2 m.

### **I. Ground Deploying and Deployed Loading**

The high power, large area, flexible blanket SAWs required for the ARM SEPM application face challenges during ground qualification and acceptance testing to verify the SAW deploying process and deployed SAW structural properties. The 1 g loading of the SAWs during ground testing is 10X greater than SAW design limits and thus weight offloading ground support equipment (GSE) is required. The GSE must support the SAW weight during ground deployments and while deployed to avoid over stressing and failing SAW structures and mechanisms. SAW offloading tends to occur at discrete locations introducing locally high stresses that must be designed for on top of the primary loading requirements associated with launch and in-space mission dynamic loading events. At the same time, the GSE must enable release of most degrees of freedom for a faithful replication of in-space, weightless deployment kinematics. Offloading the weight of advanced SAWs is challenging since most of the SAW mass is in the blankets that are distributed over a very large area and are flexible. In addition, the blankets are moving over large distances (meters to 10's of meters) during deployment. Offloading blanket membranes in 1 g tends to introduce artificially high tension loads that can over stress SAW components and lead to unrealistic dynamic response in terms of modal frequencies and damping. SAW structures are also moving during deployments, in some cases in two different planes, which also present a challenge for attaching, and maintaining the alignment of, overhead offloading elements. If offloading elements become misaligned with the gravity vector, unwanted torques and/or force imbalances are introduced. Offloading elements introduce artificial damping and can store and release energy during ground testing. These effects combine to mask the true SAW weightless deployment and deployed responses.

Since in-space weightless deployments and deployed properties measurements for ARM are cost and schedule prohibitive, high fidelity ground deployment/deployed testing and analysis is critical. Failure of a SAW deployment means the loss of mission. Deployed wing structural failure can result in loss of mission and even loss of crew if the Orion vehicle is damaged. Thus, along with high fidelity offloaded ground deployments and deployed structures modal measurements, MBD analytical modeling will be key. The MBD model of the SAW in its ground test configuration can be validated and then the same model can be used to predict weightless SAW kinematic and structural dynamic performance in space during the mission.

### **J. Others**

One other unique deployed SAW structural consideration arises from the possibility of extremely cold operation temperatures that can compromise composite structure material allowables. When operating in the stable distant Earth lunar orbit, the ARM vehicle will experience periodic lunar eclipses with typical durations of 2 to 5 hours, unless another orbit type can be selected with limited eclipse periods of < 1 hour. The advanced SAWs, with large deployed area require low areal mass blankets to meet the mass requirement. These low areal mass blankets have very low thermal capacitance and hence, their temperature responds rapidly to imposed environmental heat fluxes. Coupled with high emittance surfaces for cool operations when in the sunlight and decreasing material specific heat capacitance at lower than room temperature, the SAW blankets cool off rapidly during eclipse events. SAWs could reach eclipse temperatures below -200°C in <2 hours. Composite panel fitting epoxy adhesives undergo a ductile/brittle phase transition in this temperature regime. Fitting bond line strength may be compromised for subsequent loading events, such as an Orion docking. Thus, either greater structural margins must be maintained in critical areas at risk of being compromised and/or dedicated material/structural component coupon testing must be performed to establish accurate material allowables following the extreme cold exposure. Such testing must be accomplished using vacuum facilities with liquid helium or liquid hydrogen cryopanels that allow for the required test temperatures. These test facilities are much less common than those with liquid nitrogen cryopanels and hence, introduce far greater facility/testing costs and schedule risks associated with facility availability.

## **V. Conclusion**

This paper has covered the top structural/mechanical design considerations for the ARM SEPM SAW application. The authors conclude that to support NASA's ARM SEPM power needs, an advanced SAW is required with mass performance better than 125 W/kg, stowed volume better than 40 kW/m<sup>3</sup>, a deployed area of 200 m<sup>2</sup> (100 m<sup>2</sup> for each of two SAWs), a deployed SAW offset distance of nominally 3-4 m from the SEPM, a deployed SAW quasistatic

strength of 0.1 g in any direction, a deployed loading displacement under 2 m, a deployed fundamental frequency above 0.1 Hz and deployed damping of at least 1%. The SAW must meet KIZ requirements both while stowed and deployed and limit deployed MOIs to manageable levels. On top of these challenging requirements, the SAW design must also be tolerant extreme natural mission environments, such as extreme cold during extend eclipse periods, and also must be robust to ARM induced mission environments, such as EP plume ion sputtering material loss. The SAW must be designed to allow for high fidelity weightless simulation for ground deployments and deployed properties testing using GSE. These findings will be considered when formulating future ARM SEPM design and technical specifications.

### Acknowledgments

The authors wish to thank and acknowledge our NASA Glenn Research Center colleagues for their important contributions to this paper: Tom Cressman (structural interface design, stowed KIZ, technical review), John Heese (structural interface design/specification, stowed KIZ), Carl Blaser (deployed KIZ formulation), Bill Hughes (dynamic environments definition), Kim Otten (dynamic environments definition), Paul Solano (SEPM CAD), Jeff Hojnicky (technical review) and Dave Hoffman (technical review).

### References

- <sup>1</sup>President Barack Obama, "Remarks By the President on Space Exploration in the 21st Century," John F. Kennedy Space Center, Merritt Island, Florida, April 15, 2010.
- <sup>2</sup>Kerslake, T. W., "Advanced Solar Arrays for NASA Solar Electric Propulsion (SEP) Missions," keynote address at the *2nd AIAA Spacecraft Structures Conference*, AIAA SciTech 2015, Kissimmee, FL, January 5, 2015.
- <sup>3</sup>Yim, J. T., Sibé, F., and Ierardo, N. "Plume Impingement Analysis for the European Service Module Propulsion System." *50<sup>th</sup> AIAA/ASME/SAE/ASEE Joint Propulsion Conference*, Cleveland, OH, AIAA-2014-3883, July 2014.
- <sup>4</sup>International Docking System Standard (IDSS) Interface Definition Document (IDD), Rev. D, International Space Station (ISS) Multilateral Control Board (MCB), April 30, 2015.
- <sup>5</sup>NASA Docking System (NDS) Interface Definitions Document (IDD), JSC 65795, Revision J, Development Projects Office, International Space Station Program, September 30, 2014.