

Laser Pulse Production for NASA's Global Ecosystem Dynamics Investigation (GEDI) Lidar

Paul R. Stysley, D. Barry Coyle, Greg B. Clarke, Erich Frese, Gordon Blalock, Peter Morey, Richard B. Kay, Demetrios Poullos, Michael Hersh
 NASA-Goddard Space Flight Center, Code 554, Greenbelt, MD USA, 20771;

ABSTRACT

The Lasers and Electro-Optics Branch at Goddard Space Flight Center has been tasked with building the Lasers for the Global Ecosystems Dynamics Investigation (GEDI) Lidar Mission, to be installed on the Japanese Experiment Module (JEM) on the International Space Station (ISS)¹. GEDI will use three NASA-developed lasers, each coupled with a Beam Dithering Unit (BDU) to produce three sets of staggered footprints on the Earth's surface to accurately measure global biomass. We will report on the design, assembly progress, test results, and delivery process of this laser system.

Keywords: Lidar, laser, oscillator, Nd:YAG, Q-switch, ISS

1. INTRODUCTION

The fundamental architecture of the GEDI laser makes use of the High Output Maximum Efficiency Resonator (HOMER) class laser system. The HOMER laser has been developed for over a decade; designed to reduce part count and maximize reliability for space flight applications. The system has evolved from an Armandillo et. al design since its first bread-boarded results in 1997.^{2,3} This laser architecture has largely remained unchanged through many years of efforts to achieve this high level of reliability and long demonstrated life. Mechanically, the laser has evolved and tested continually through several improvements, both at the component and system levels. All the cavity components for the HOMER design have been tested to the Technology Readiness Level (TRL) 6 level, or have flown on previous missions (TRL9). HOMER's success was leveraged for the GEDI program and has since been modified again to achieve the required laser output performance to achieve the science mission goals^{4,5}.

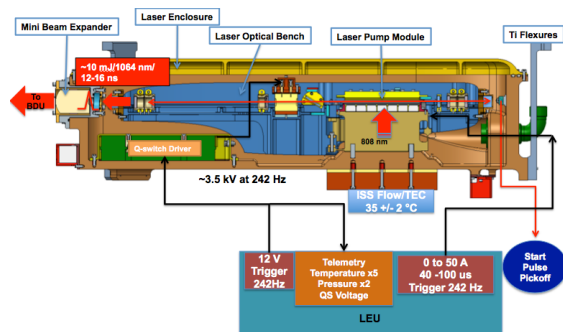

2. THE GEDI LASER ARCHITECTURE OVERVIEW

The GEDI laser overview and interface summary can be seen in Figure 1. The GEDI laser is primarily responsible for providing 10 mJ Q-switched laser pulses at 1064 nm. The oscillator-only laser consists of the optical bench and pump module, discussed later, and is kept in a pressurized laser enclosure. Inside the enclosure will be the high voltage Q-switch electronics, a start pulse optical pick-off, pressure and temperature sensors, and internal harnessing. Electrically,

Figure 1. GEDI Laser cross section and interface overview. This shows the orientation for assembly prior to installation aboard GEDI.

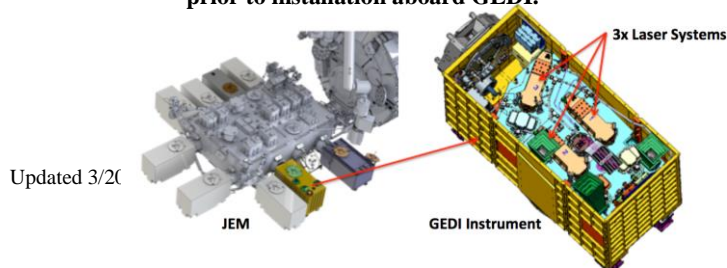

the laser interfaces with the Laser Electronics Unit (LEU), which provides the Q-switch voltage and trigger along with laser diode drive current, and receives the temperature and pressure level telemetry. A liquid-based chiller plate and Thermal Electric Cooler (TEC) will hold the diodes at 35 C, and mounted to the housing exterior. Optically, there is a monolithic mini-beam expander to provide the output divergence needed for the mission. Finally, the 3 titanium flexures mount to the GEDI optical bench. The JEM module and GEDI instrument can be seen in Figure 2

Figure 2. The GEDI lasers will be integrated onto the GEDI Instrument seen on the right. This will be delivered to the

3. DESIGN REQUIREMENTS

Table 1 summarizes the driving requirements for the GEDI laser design. The GEDI project has been very careful to flow down requirements to the laser team that maximizes science with achievable hardware goals from an engineering perspective. These requirements along with a list of driving test parameters will be trended through the build of the ETU and flight units.

Table 1: GEDI Laser Driving Requirements

Requirement	Value
Laser Wavelength	1064.5 nm ± 0.2 nm in vacuum
Maximum Allowable Laser Energy	10 mJ +/- 5% fully-apertured beam at the output
Far-Field Divergence of the Central Lobe	1.8mrad ±0.08mrad
Laser Output Polarization Ratio	≥ 200:1
Pulse Repetition Rate	242 +/- 2 Hz
Pulse Width	≤ 16 ns FWHM
Laser Pulse Energy in Far-Field Outside of Central Lobe	≤ 0.5% of 1/e ² Central Lobe
Laser Lifetime	3.2 Billion Shots
LDA Operating Temperature	35 +/- 2 °C

4. LASER DESIGN

4.1 Laser Cavity Summary

The HOMER class design used for the GEDI laser is a flight quality Nd:YAG, diode-pumped solid state oscillator-only cavity producing beam qualities and pulse energies typically associated with master oscillator power amplifier (MOPA) systems. The HOMER lasers achieve this with high efficiency, low part count, and a demonstrated long life, running continuously for over 2 years (>16 billion pulses). This laser employs a side-pumped zigzag slab in a stable cavity which can make it difficult to achieve a TEM₀₀ mode without the use of passive beam shaping. The use of porro-prisms and/or intra-cavity apertures can be used to produce quality single mode beams. However, these items have proven to generate intense optical diffraction effects and reduce overall optical damage resistance. These induced optical perturbations reduce the effective, average optical damage threshold of all the cavity’s components by introducing

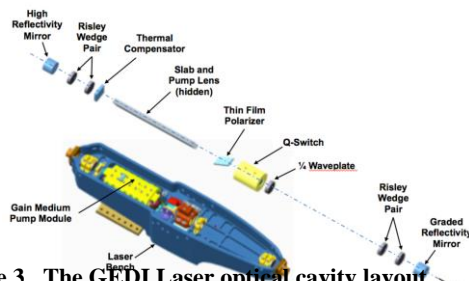

Figure 3. The GEDI Laser optical cavity layout featuring a 22 bounce slab and a GRM can be seen

optical spiking, temporal and spatial, and constructive interference effects within the optical materials and coated surfaces. This hinders the total reliability, introduces intensity jitter, and ultimately degrades the performance of the final laser system. If one is successful with the implementation of these methods in producing damage free operation TEM₀₀ in such a laser, the optical efficiency is always reduced and the many of the zigzag slab advantages are lost. Alternatively, with a Graded Reflectivity Mirror GRM-based cavity design, in concert with an optimally pumped zigzag slab, these issues are greatly reduced and the finer details of safe cavity operation can be studied⁶.

Using a GRM as the output coupler, TEM₀₀ pulse energies are readily obtainable from a >10 mJ oscillator-only design and are suddenly highly scalable because a relatively large intracavity low-fluence beam is created as the system's beam quality foundation. The final optical design makes use of a 40 cm cavity length. It employs a positive (concave) radius of curvature (ROC), 99.9% HR mirror along with the negative (convex) 237 cm ROC GRM using an effective average reflectivity and peak reflectivity of approximately 32% and 65%, respectively. To produce a gain-switched laser pulse of 1064 nm, an active Q-switch is employed, comprised of an electro-optic (EO) poekel's cell, and a pair of passive polarizing optics; a quarter wave plate and thin film polarizer (TFP). As part of the GEDI program, all delivered optics that have coatings will have witness samples go through laser induced damaged testing (LIDT). Using the LIDT values along with models and verified experimental results over the past decade allow the laser team to know what energy level is safe for the laser to run at for a specific configuration. The optical layout is seen in Figure 3.

4.2 Laser Gain Pumping Scheme

HOMER's gain module, or laser head, employs 7 stacks of 4-bar 809 nm LDAs which pump a 22-bounce zigzag slab of 1.1% doped Nd:YAG. These highly astigmatic beams from these 28 bars are concentrated with the use of a long, plano-convex cylindrical lens made of undoped:YAG. This produces a highly concentrated gain region of similar dimension across the Nd:YAG's cross section, normal to the cavity optic axis, from which its stored energy is efficiently extracted by the resonant cavity mode. In fact because the system is so efficient the diode pump is significantly derated giving the laser system plenty of margin to recover from any unexpected laser loss. The diodes being employed can run at least as high as 100 A and 200 μ s. Comparatively, when the laser is configured to run with an output energy of 10 mJ the diodes are pumped at 50 A and as little as 40 μ s. When assembling the diode pump module, the distance between the pump lens to the diode faces is closely monitored, as placing them in regions where small absorption peaks along the pump surface has been proven to produce and trigger optical damage from microlensing effects⁴.

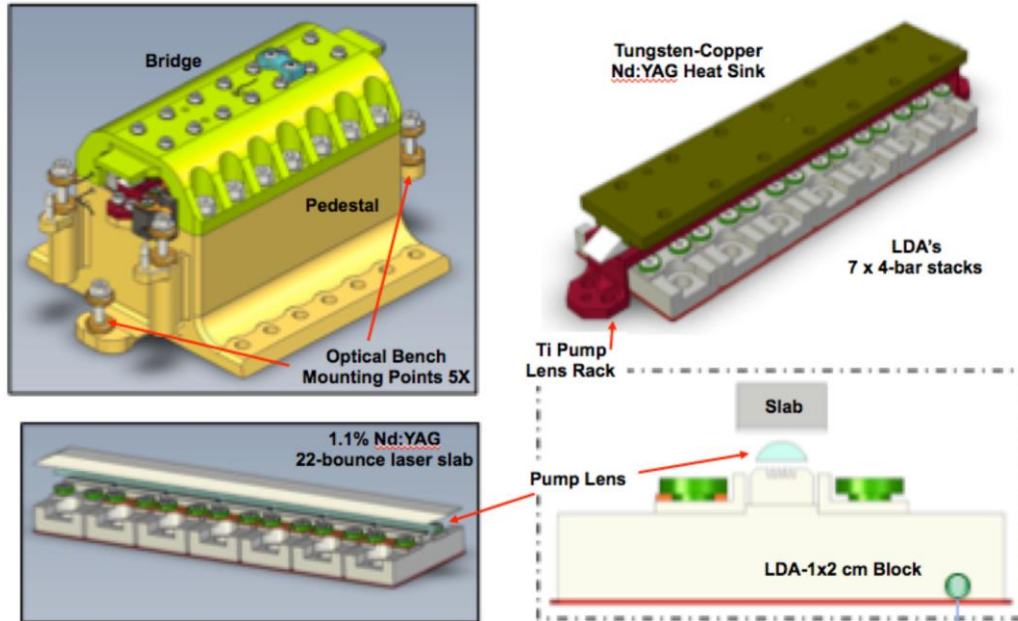

Figure 4. The diodes are mounted to the aluminum pedestal, which thermally mounts to the enclosure floor. The laser slab is mounted to the W:Cu heat sink and to the aluminum bridge. The pump lens lies between the slab and diodes with high precision placement. They are all combined to make the full assembly, seen in the upper left

4.3 Mechanical Summary

The GEDI laser mechanical design allows for subcomponent modularity and is divided into 3 major sections: the enclosure, the pump module, and the optical bench. All three sections are primarily made of aluminum with the exceptions of some of the optical mounts and the titanium flexures interfacing with the instrument optical bench. Each are have design requirements principally driven by maintaining GEDI bore sight over the environmental conditions through the life time of the mission. Finite element modeling has been performed on the entire design and was found to meet all the bore sight jitter and alignment requirements. Further the laser enclosure is required to keep the laser pressurized at least 1 atm over the life time of the mission. An identically made enclosure will be made to qualify the pressure seal design. The mechanical design requirements will be confirmed with the ETU during environmental qualification testing as well.

This modular hardware design, levied by the laser team, allows for frequent optical inspections throughout the assembly and alignment process. Any issues that may occur over the laser builds can be quickly resolved with minimum invasive techniques, and without the need for cavity realignment. Furthermore, the optical bench, shown in Figure 3, can be removed from the pump module, Figure 4, fully aligned and operated without the enclosure if necessary. Therefore, both can be manufactured, tested, and characterized independently and in parallel. This nonlinear manufacture capability helps to reduce schedule and cost. The full aluminum assembly, sans the Titanium optical mounts, will be a little more than 9 kg in mass, shown in Figure 5.

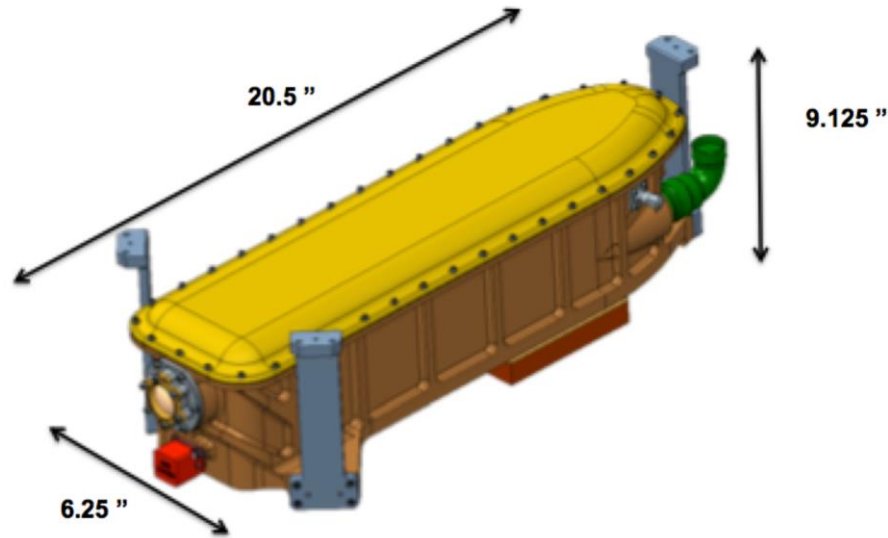

Figure 5. The full GEDI laser assembly is seen above. Note; the laser will be built in this orientation, sealed, pressurized, and then inverted 180° when it is mounted on the GEDI optical bench. This allows for easy access to the laser head thermal interface with which to mount the JEM thermal plates and TECs.

4.4 Thermal considerations

The GEDI laser design requires active conductive cooling in order to maintain the desired Nd:YAG absorption pump wavelength from the laser diode arrays (LDAs). Additionally, stable operating temperature must be maintained in order to guarantee the required turn-on time while in orbit. The JEM-provided liquid cooling loop requires additional active control since the fluid's temperature arriving at each laser experiences a 6C° temperature swing, depending on the other heat loads in its path. Therefore, a pair of thermo-electric coolers (TEC) will reside between the laser base and the JEM liquid thermal plate. This will keep the pedestal and LDAs within the 35⁰ (±2) C° when the laser is off or in standby mode. Otherwise, the optical bench and enclosure are designed such that internal thermal stresses will not affect laser performance. The laser system will be tested over a full survival range of 50 C° to -10 C° during thermal vacuum testing.

4.5 Laser Performance Summary

Each GEDI laser fires at 242 Hz and produces 11-16 ns Q-switched pulses at 10-17 mJ, with a TEM₀₀ beam quality at 1064 nm. This mission needs a reliable laser that will last a minimum of 3.2 billion shots (33% duty cycle on average per orbit) over the lifetime of the mission. We recently published a complete lifetime dataset where we ran our HOMER-2 laser for over 15x10⁹ shots. This was the equivalent of 2 years of continuous operation with a measured decay rate of only ~ 0.1 mJ/Billion. Therefore, this laser design provides plenty of life-time margin for the GEDI mission. This life test demonstrated the advantages of an oscillator-only design, with a specific set of requirements, over an equivalent MOPA system when producing TEM₀₀ laser pulses under 20 mJ. Even with the extensive development history, qualification, and data sets of the HOMER laser design, the GEDI mission laser performance requirements required that design be modified slightly from the HOMER-2 TRL6 system. These modifications have since been implemented in the HOMER-1 engineering unit which readily achieved 3.2 billion shots (the mission requirement) at the necessary energy output levels in a recent long term run. Pre-, and post-run inspections show damage-free operation at these parameters, further demonstrating the validity of the HOMER oscillator concept. Any remaining laser performance requirements were tested on the GEDI laser breadboard system. It is to be noted that as part of this testing, known damage triggers for the laser system, including longitudinal mode beating and small scale self focusing, are monitored continuously through out the testing process. Finally, the highest risk optics, determined from laser induced damage testing and high precision mathematical models, (the GRM and laser slab), are inspected for optical damage after each major experiment or any step change in operation. A summary of the laser performance can be seen in Figure 6.

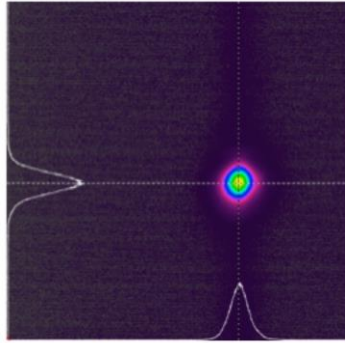

Parameter	10mJ	Unit
Energy	10.1	mJ
Divergence X	1.19	mRad
Divergence Y	1.29	mRad
Beam Width X	1.19	mm
Beam Width Y	1.30	mm
Pulse Width	15.5	ns
Polarization	819:1	Ratio

4.6 Laser Build and Test Plan Overview

The laser team has been tasked with delivering an ETU laser, three flight units, and a flight spare. The GEDI ETU laser has hardware has been fabricated and has started assembly. The ETU and flight lasers will go through the same assembly and test processes with the general exception that lessons learned” during the ETU build will be carefully documented, evaluated and implemented on the flight builds. Both ETU and flight units will use custom designed electrical and optical ground support equipment (GSE). The electrical GSE will have the role of simulating the LEU **Figure 6. A summary of the GEDI laser performance while configured to run with 10 mJ output energy. Note; these values are without use of the mini-beam expander.**

along with taking all of the required data needed to record laser performance. The comprehensive performance test will be run in this configuration before and after each phase of environmental testing. The optical GSE seen in Figure 7.

The GEDI Laser units will run vibration testing as spelled out in the GEDI Structural/Mechanical Loads Document. The lasers will be tested unpowered in the X, Y and, Z axis. The laser will be performance tested in between vibration runs primarily looking for any change in laser beam quality and any movement on the alignment bore sight.

The ETU and Delivered flight units will carry out TVAC as spelled out in the GEDI Thermal Interface Control Document. At this time each flight laser will go through 8 survival cycles. Survival temperatures range from 50 to -10 C. During each cycle the laser will pause at the operating temperature ranges to check powered on laser performance. The TVAC test will also serve as another confirmation of the pressurized cavity design.

Once the environmental testing is completed the ETU will start life testing well before the delivery of the flight units. During the testing monitoring laser requirements will be monitored continuously and it will engineering unit interface testing with other hardware such as the BDU. The flight units will be delivered straight for integration with the GEDI instrument and then will support instrument level performance and environmental as required.

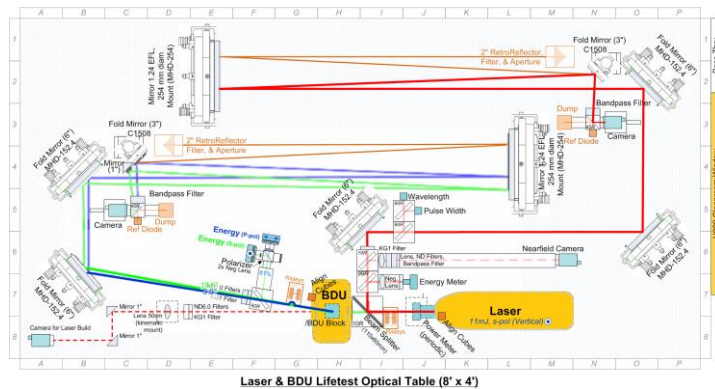

Figure 7. The optical GSE will be used for the BDU and Laser ETU life testing, along with the ETU laser CPT testing. A similar configuration will be used to test the flight lasers.

5. CONCLUSION

The GEDI Instrument installed on the ISS JEM platform will produce a valuable 3D, multi-seasonal, global biomass data set. The GEDI mission is employing a robust HOMER class laser, which has been thoroughly tested over several different models, and meeting key performance parameters. The GEDI laser has large overhead in LDA derating, well known and measurable damage triggers, and quantified margins in thermal and optical space. Sound and proven development processes, qualification plans, and infrastructure hardware is in place or under assembly at this time as we ready for the completion of the ETU unit, and prepare for the arrival of flight hardware soon after. Finally, based on HOMER's extensive data set, and the GEDI laser's solid foundation and relative performance adjustments, the risk-space for each laser is approximately equal, and thus we expect similar life time capability should the GEDI mission be extended.

REFERENCES

- [1] <http://science.nasa.gov/missions/gedi/>
- [2] D. B. Coyle, R. B. Kay and S. J. Lindauer, "Design and performance of the vegetation canopy Lidar (VCL) laser transmitter," *Aerospace Conference Proceedings, 2002. IEEE*, 2002, pp. 3-1457-3-1464 vol.3.
- [3] Errico Armandillo, Callum Norrie, Alberto Cosentino, Paolo Laporta, Paul Wazen, and Patrick Maine, "Diode-pumped high-efficiency high-brightness Q-switched ND:YAG slab laser," *Opt. Lett.* 22, 1168-1170 (1997)
- [4] Donald B. Coyle, Richard B. Kay, Paul R. Stysley, and Demetrios Poullos, "Efficient, reliable, long-lifetime, diode-pumped Nd:YAG laser for space-based vegetation topographical altimetry," *Appl. Opt.* 43, 5236-5242 (2004)
- [5] Paul R. Stysley, D. Barry Coyle, Richard B. Kay, Robert Frederickson, Demetrios Poullos, Ken Cory, Greg Clarke, Long term performance of the High Output Maximum Efficiency Resonator (HOMER) laser for NASA laboG s' Ecosystem Dynamics Investigation (GEDI) lidar, *Optics & Laser Technology*, Volume 68, May 2015, Pages 67-72.
- [6] Moran, M., "Graded Reflectivity Mirror Unstable Laser Resonators", *Opt. and QE* 29, 819-866 (1997).