



Spacecraft Charging Technology Conference  
04 - 08 April 2016

European Space Agency

# Deep Charging Evaluation of Satellite Power and Communication System Components

*-NASA Marshall Space Flight Center-*

Todd Schneider, Jason Vaughn, Ken Wright,

Brandon Phillips and Brian Chu

*-Space Systems/Loral, LLC (SSL)-*

Kit Frankie Wong and George Gardiner

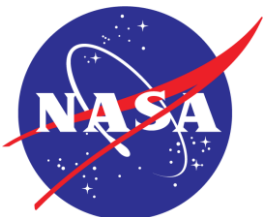

# Motivation

- SSL has been using Electric Propulsion thrusters for many years to provide station-keeping of their communication satellites in Geosynchronous Earth Orbit (GEO)
- A logical extension of SSL's electric propulsion program was to provide Electric Orbit Raising (EOR) services
  - EOR missions benefit from reduced launch mass and increased on-orbit payload (compared to traditional chemical propulsion technologies)
- A trade-off associated with EOR is the unavoidable transits through Earth's radiation belts
- Exposure of satellite systems to high energy charged particle environments in the radiation belts provides an opportunity to experience deep charging scenarios

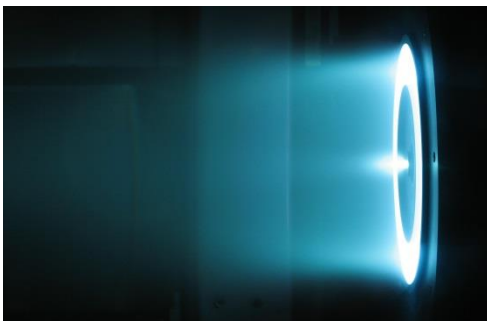

Credit: JPL



Credit: SSL

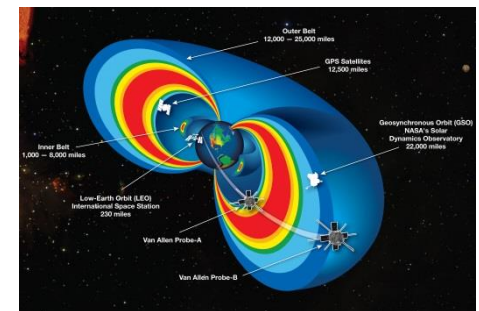

Credit: NASA RBSP

# Deep Charging

- For the work described here, “Deep Charging” or “Internal Charging” refers to charge penetration deep into an insulating material (dielectric)
  - As Garrett notes, internal charging can also occur on/in an electrically floating conductor [1]
- Typically testing focuses on electron penetration into the material, since the range of electrons is much greater than ions with the same energy
- Primary interest in deep charging is focused on scenarios in which the charged insulator is in close proximity to a conductor (particularly a grounded conductor)
- **The threat associated with deep charging is the formation of an electrostatic discharge (ESD) or electrical arc**

*When the electric field strength exceeds the dielectric strength of the material an Electrostatic Discharge (ESD) can occur*

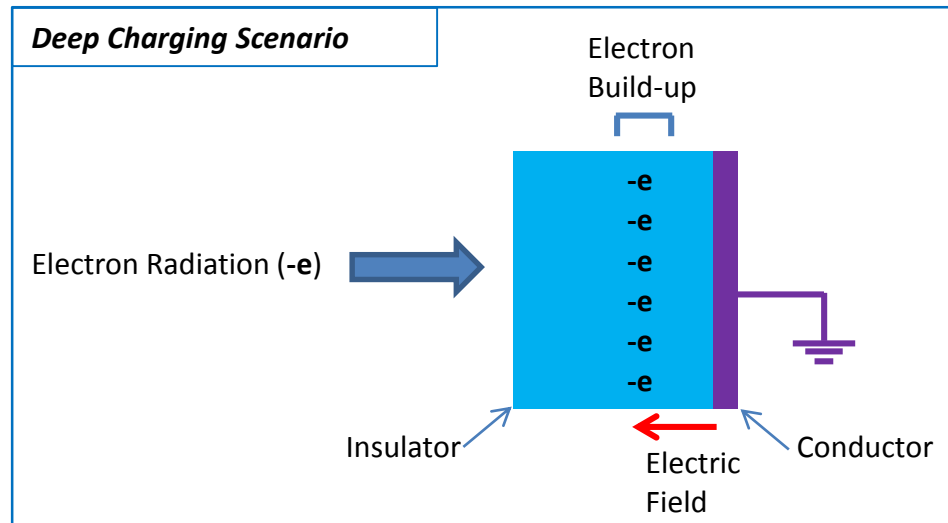

*Electrostatic Discharge (ESD) events or “arcs” can damage insulators, disrupt digital signals, and even destroy sensitive electronics*

# Deep Charging Test/Evaluation

- The potential deep charging risk associated with EOR missions warranted testing of critical systems on SSL spacecraft including power and communication systems (since they were directly exposed to the environment)
- SSL partnered with NASA's Marshall Space Flight Center to perform deep charging tests of flight-like coupons scaled to fit in the vacuum test chambers

Solar Array Power System

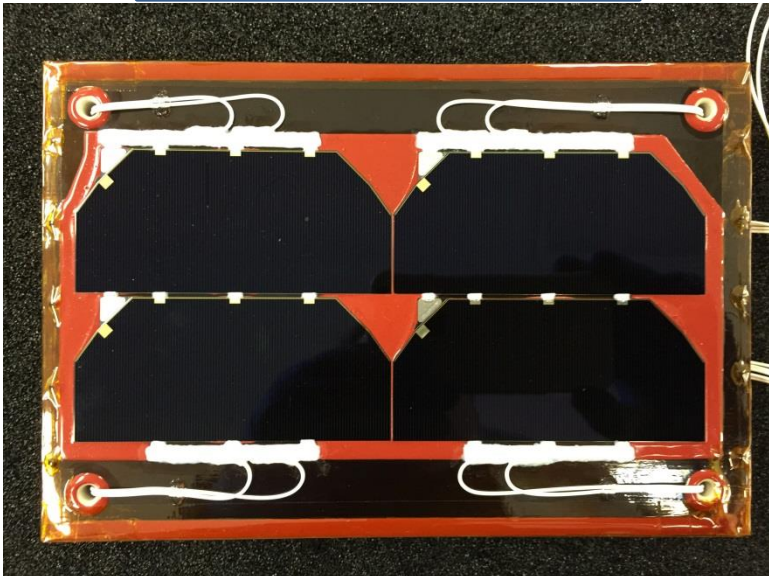

Cell Interconnect Coverglass (CIC) Coupon  
(Photovoltaic Cells Arranged in 2 Strings)

Microwave Communications



Semi-Rigid Coaxial Cable  
(SMA Connections)

# Wire Coupons

- Wire coupons are scaled versions of solar array wiring systems
- Solar array wiring can carry multi-amp currents
- Wiring systems are on both the front (sun facing) and back side of the solar arrays

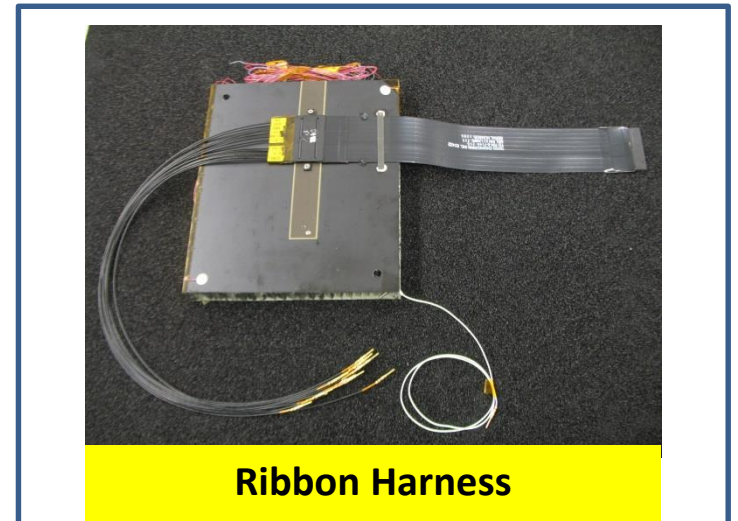
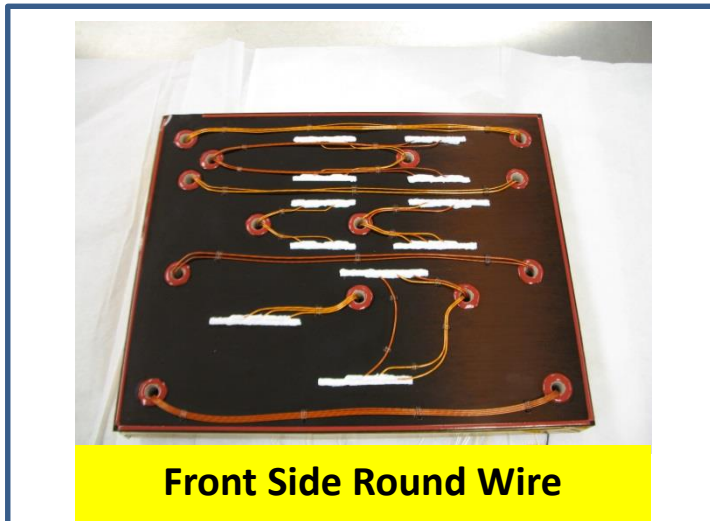

# Establishing Test Energies

- Electron penetration into a material can be modeled
- SSL modeled electron penetration into materials and assemblies associated with the Wire and CIC coupons as well as the Coaxial Cable
- The electron energies used in the test were chosen based on simulations of electron range in all of the relevant dielectrics on the samples
- **Two energies were selected for the test: 1 MeV and 300 keV**

## Appendix 2 – Coax Simulation

- ◆ Coax simulation with 1MeV energy (about 12 mils outer shield and 40mils PTFE)

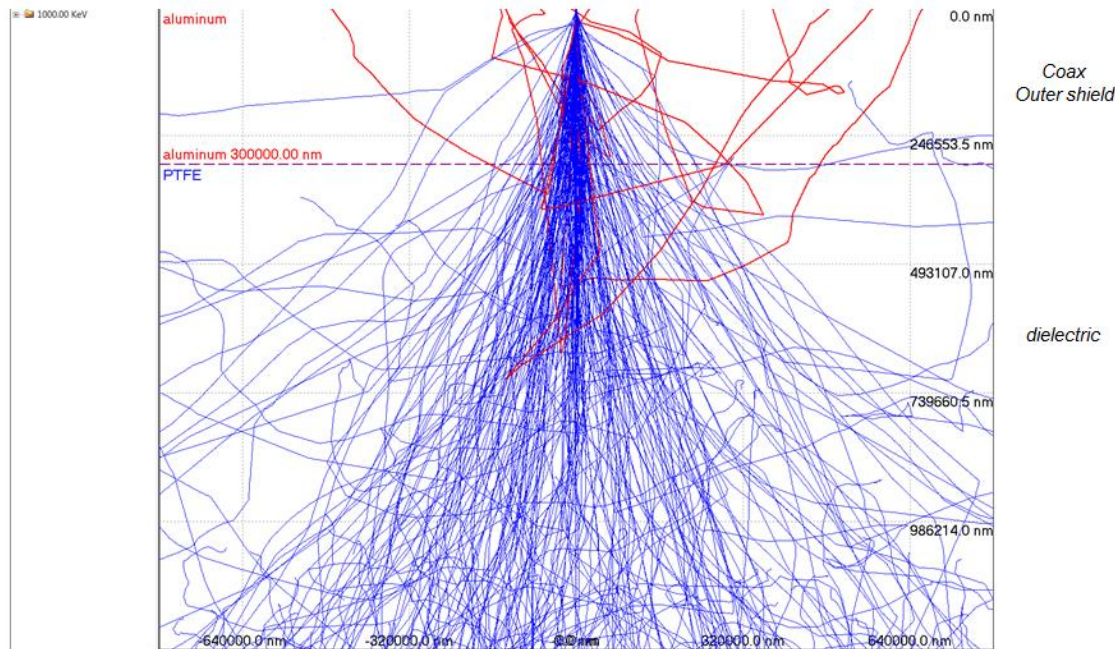

SSL model of electron penetration in a coaxial cable.

The model predicts the majority of electrons penetrate deep into the Teflon (PTFE) Insulator (aka “dielectric”)

# Flux and Fluence Levels

- SSL analyzed the EOR mission profiles and established expected electron flux and fluence levels
  - Detailed description of this process is provided by Wong in a separate paper at this conference [2]

## Electron Exposure Test Levels for CIC Coupon and Coaxial Cable Sample

Coupon Description	Fluence at 300 keV (e-/cm <sup>2</sup> )	Fluence at 1 MeV (e-/cm <sup>2</sup> )	Electron Flux (nA/cm <sup>2</sup> )	Exposure Time at 300 keV (hrs)	Exposure Time at 1 MeV (hrs)
CIC Coupon	3.56E12	8.4E11	0.03	5.3	1.25
Coaxial Cable	3.56E12	8.4E11	0.03	5.3	1.25

## Electron Exposure Test Levels for Wire Coupons

Coupon Description	Fluence at 300 keV (e-/cm <sup>2</sup> )	Fluence at 1 MeV (e-/cm <sup>2</sup> )	Electron Flux (nA/cm <sup>2</sup> )	Exposure Time at 300 keV (hrs)
Wire Coupon (front side)	3.56E12	N/A	0.03	5.3
Wire Coupon (back side)	3.56E12	N/A	0.03	5.3
Ribbon Coupon	3.56E12	N/A	0.03	5.3

# Deep Charging and Electrostatic Discharge (ESD) Detection

- Deep charging ESD occur as a result of dielectric breakdown in a charged insulator
- Typically, breakdown of an insulator is accompanied by a flow of electrons out of the insulator into a nearby conductor (at a lower potential)
- The flow of electrons into a conductor is measured as current flow

Inductive Current Probes were the key diagnostic for detecting ESD

Substrate steady state current levels monitored to verify electron beam application

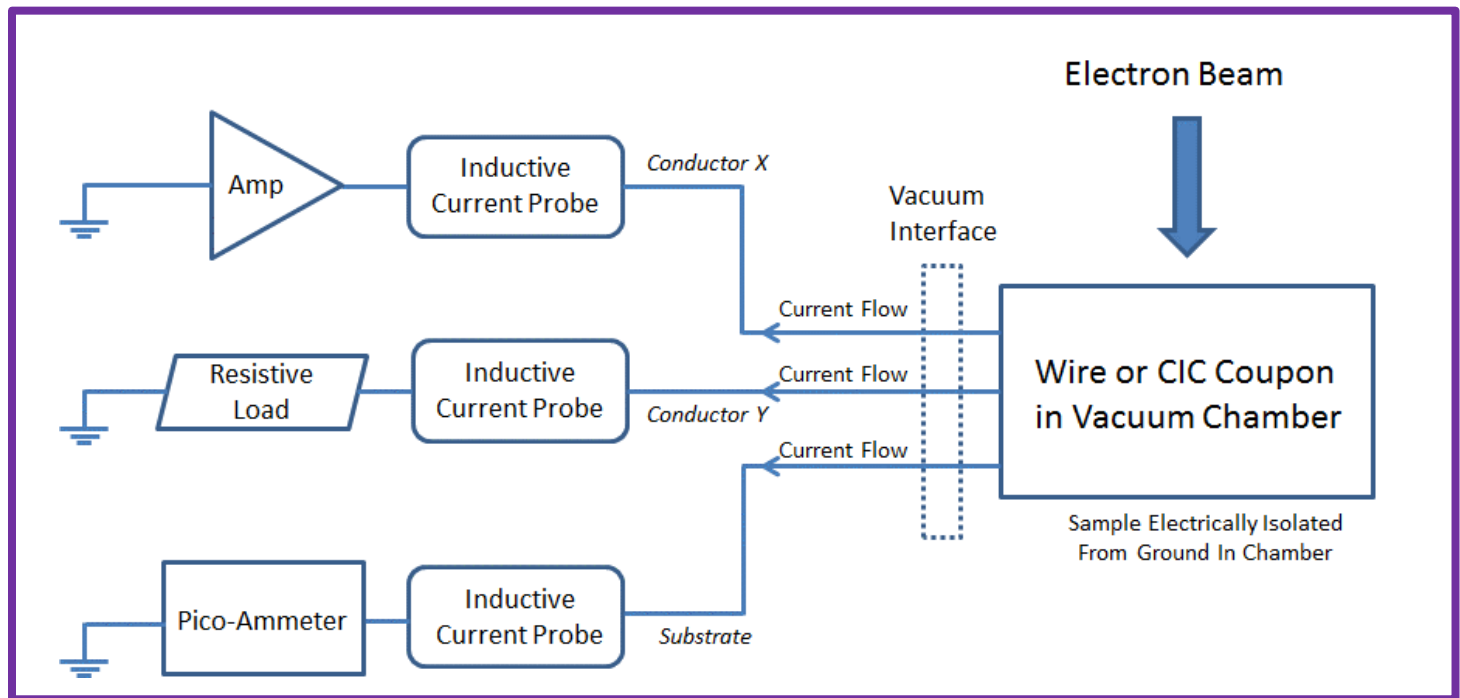



# Test Setup: The Quest to be “ESD Clean”

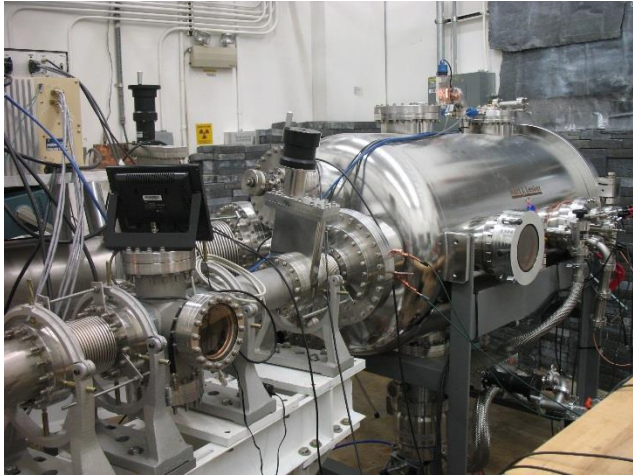

Electron Beam Line and Sample Chamber

Must minimize ESD due to surface charging and ESD on feed-through wiring

Thick-walled tubes stop the primary electrons from charging the feed-through wiring

Wire connections are “hidden” behind the sample mounting plate which acts as shielding

Foil applied to connection wires to minimize surface charging due to scattered electrons

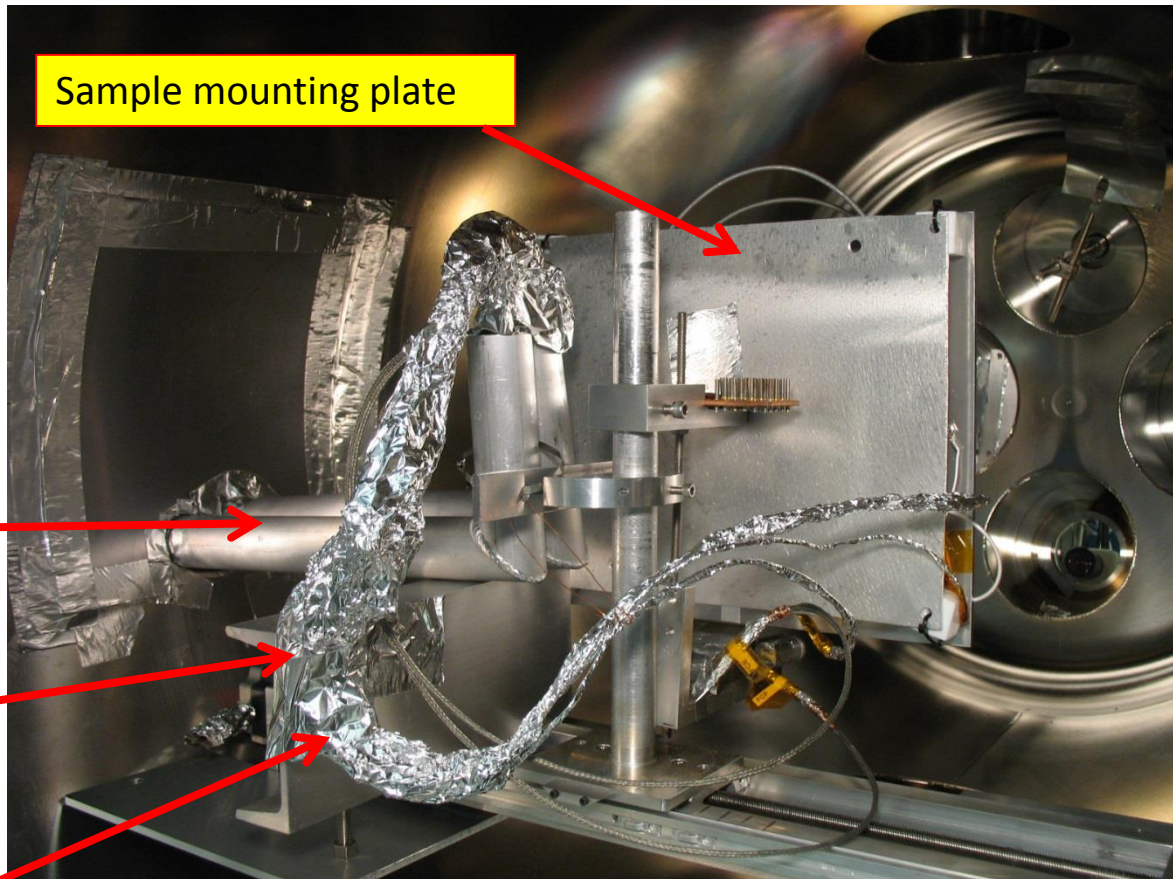

Inside the Sample Chamber – Behind the Sample Mounting Plate

# Anatomy of an ESD Event

## Front-side Round Wire Coupon

Small peak magnitude

Almost identical to B-wires. Suggests induced current waveforms

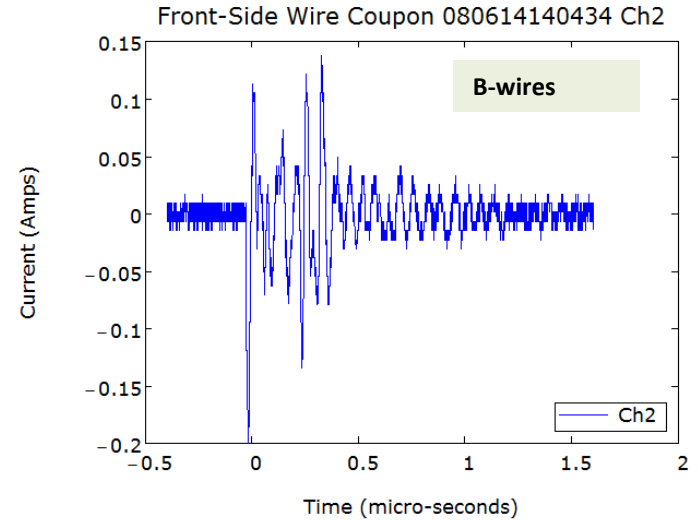
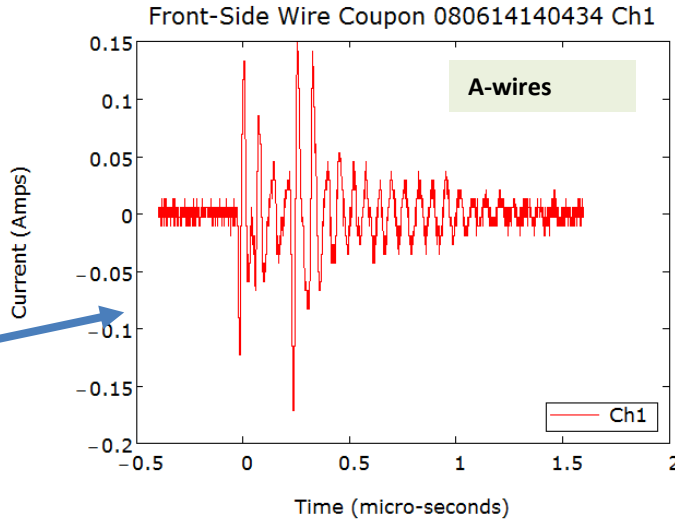

Unique signature

Negative-going pulse

Higher peak magnitude than other signals

Pulse width larger than other channels

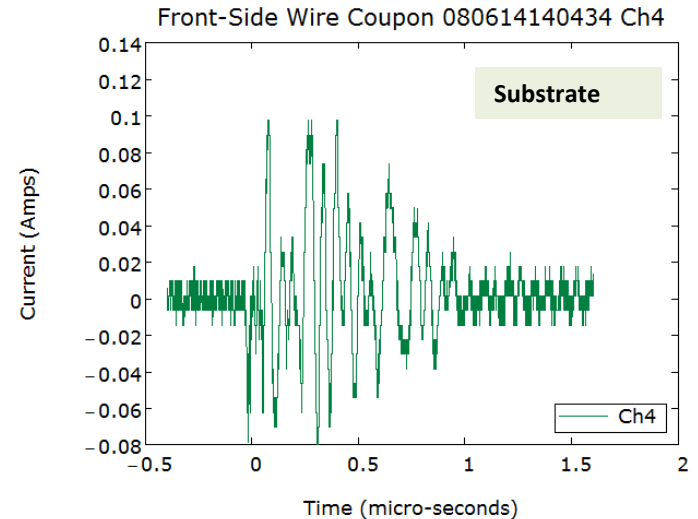
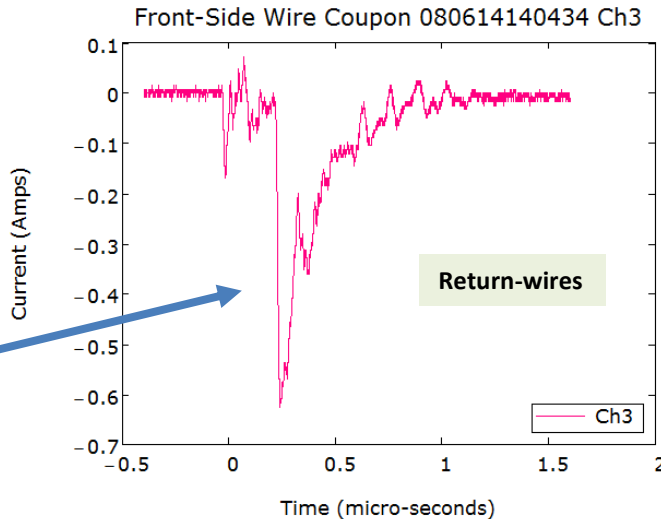

# Results Summary: Passive Circuit Tests

The objective of the passive circuit tests was to determine if any deep charging ESD events occurred, and establish overall magnitude levels

Passive Circuit Testing					
Sample	Electron Energy (MeV)	Exposure Time (Hours)	No. of Scope Triggers	No. of Deep Charging ESD Events	Largest Peak ESD Current Detected
Front Side Wire	0.3	5.3	65	8	700 mA
Back Side Wire	0.3	5.3	26	1	500 mA
Ribbon Harness	0.3	5.3	5	2	120 mA
Coaxial Cable (w/bleed resistors) 1.6X Flux	0.3	1.0	0	0	0 A
Coaxial Cable (w/bleed resistors) 1X Flux	1.0	1.3	0	0	0 A
Bare Aluminum (Control) 1X Flux	0.3	2.0	7	0	<200 mA
Bare Aluminum (Control) 3X Flux	0.3	0.5	6	0	<200 mA
Bare Aluminum (Control) 1X Flux	1.0	1.0	1	0	<200 mA
Bare Aluminum (Control) 8X Flux	1.0	0.5	0	0	0 A

Control tests conducted to help differentiate spurious signals from deep charging ESD's

All inductive current probes were connected to a fast oscilloscope ("scope") channel. A majority of the scope triggers did not meet the criteria associated with a deep charging ESD waveform (see chart titled "Anatomy of an ESD Event")

# Results Summary: Active Circuit (Powered) Tests

The objective of the active tests was to determine if a deep charging ESD event would lead to a sustained arc. Each sample was connected to a Solar Array Simulator (SAS) power supply set to typical satellite power levels.

Active Circuit Testing						
Sample	Electron Energy (MeV)	Exposure Time (Hours)	SAS Voltage (Volts)	SAS Current (Amps)	No. of Scope Triggers	No. of Sustained Arc Events
CIC (Solar Cells) [1400 Volt Bias]	0.3	5.3	108	0.55	1	0
CIC (Solar Cells) [1400 Volt Bias]	1.0	1.25	108	0.55	0	0
CIC (Solar Cells) [0 Volt Bias]	0.3	5.3	108	0.55	59	0
CIC (Solar Cells) [0 Volt Bias]	1.0	1.25	108	0.55	9	0
Front Side Wire	0.3	5.3	108	4.0	11	0
Back Side Wire	0.3	5.3	108	4.0	3	0
Ribbon Harness	0.3	5.3	108	4.0	0	0

**No sustained arcs were found.**

# Conclusion

- A deep charging test campaign devised by Space Systems Loral (SSL) has been carried out at NASA's Marshall Space Flight Center (MSFC)
- The test campaign focused on engineering evaluations of flight-like samples
  - Solar array wire coupons (3 types of wiring systems)
  - A photovoltaic cell coupon (known as a "CIC" coupon)
  - A semi-rigid coaxial cable (used for microwave communication systems)
- Two types of tests were conducted: Passive Circuit and Active Circuit
  - Active circuit tests involved applying power to the sample under investigation. Power levels were commensurate with typical SSL satellite operating conditions
- Based on detection of current pulses generated during passive circuit testing, there is evidence that some Electrostatic Discharge (ESD) events did occur as a result of deep charging
- **All samples showed no signs of damaging or sustaining arcs due to deep charging**



Credit: Space News

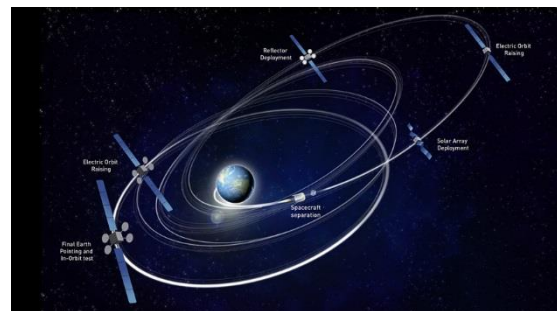

Credit: Space News

# References

- [1] H. B. Garrett and A.C. Whittlesey, "Spacecraft Charging, An Update", *IEEE Transactions On Plasma Science*, VOL. 28, NO. 6, December 2000
  
- [2] Kit Frankie Wong and Wousik Kim, Deep Charging Requirement and Analysis Approach for EOR to GEO, Paper No. 0030, Proceedings of the 14th Spacecraft Charging Technology Conference, ESA/ESTEC, Noordwijk, NL, 04-08 April 2016

Deep Charging Test

# **BACKUP INFORMATION**

# Anatomy of a Signal that is NOT a Deep Charging ESD Event

Not a Deep Charging Event

Overall current magnitudes are very low

No unique waveforms

Suspect all signals are induced from a surface discharge elsewhere in the system

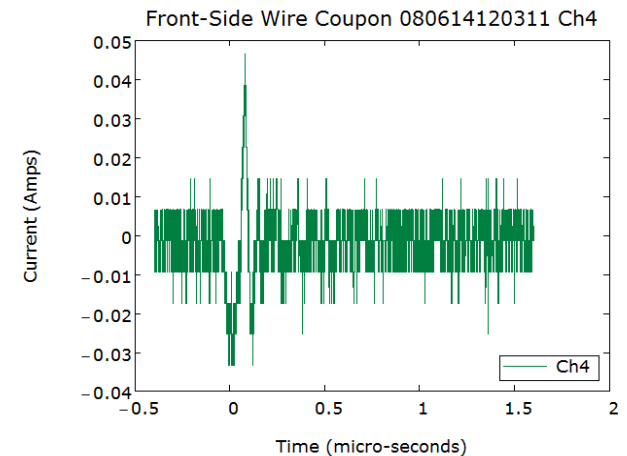
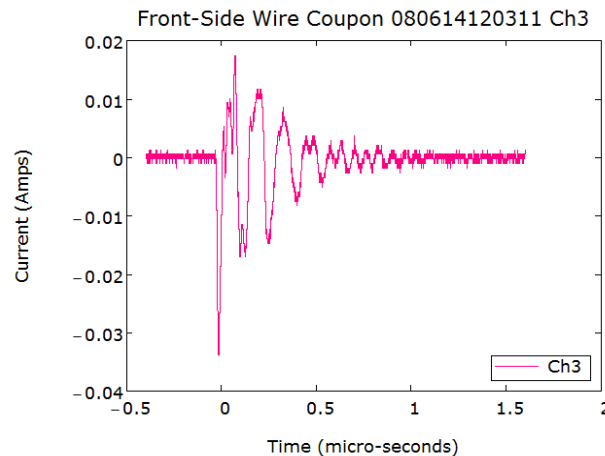
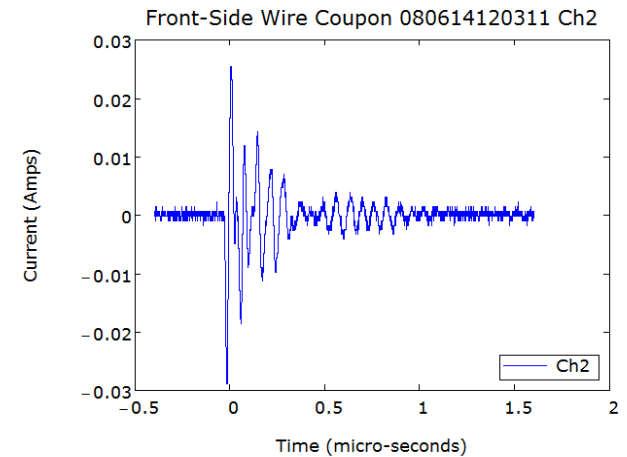
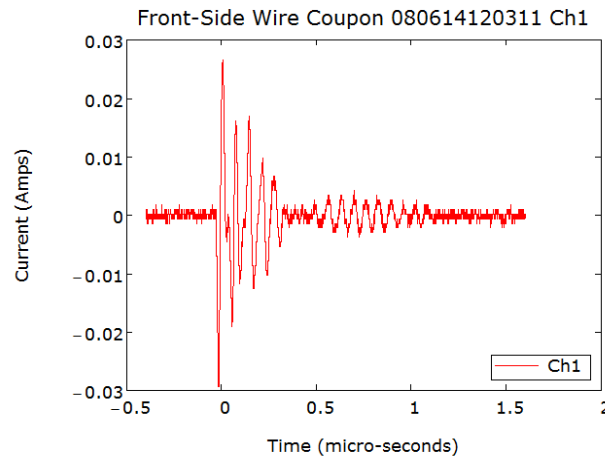



# Bare Aluminum Plate Control Test

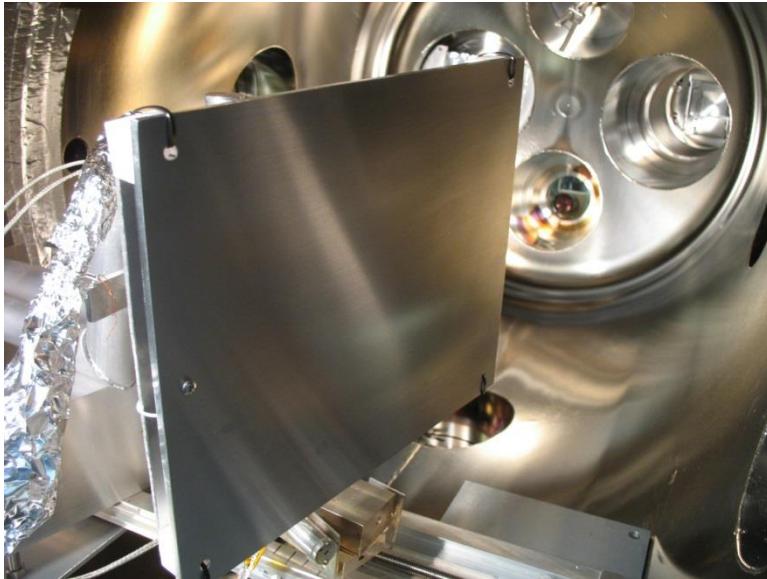

- Bare Aluminum plate mounted using the same methods as official test coupons
- Any ESD events detected can be ascribed to test setup (chamber) issues
- Useful for finding noise floor

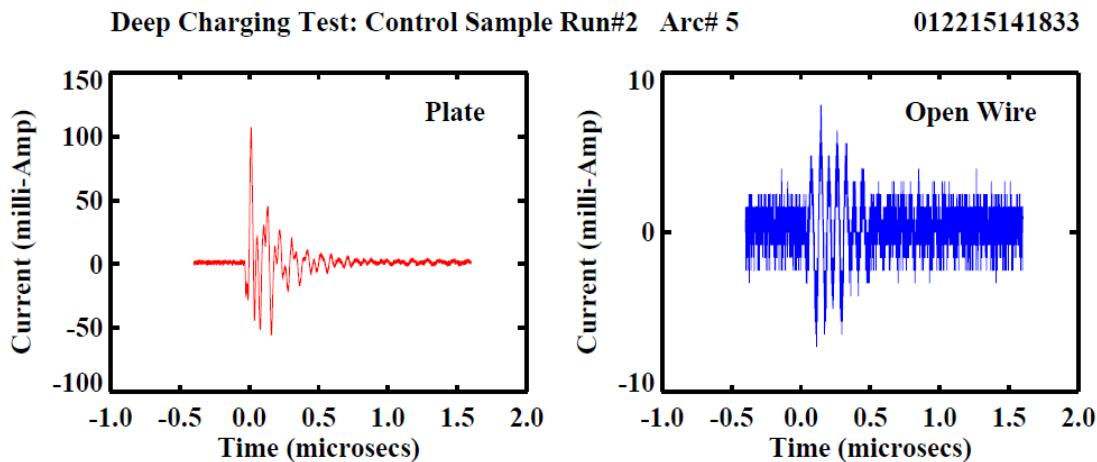

Typical signals detected by oscilloscope

Peak currents of only 100 milli-amps (with considerable ringing)

“Open Wire” strictly detects induced noise in the system

Provides signal form and magnitude information for effective noise that can be ignored in official coupon tests

# CIC Coupon Active Circuit Test Setup

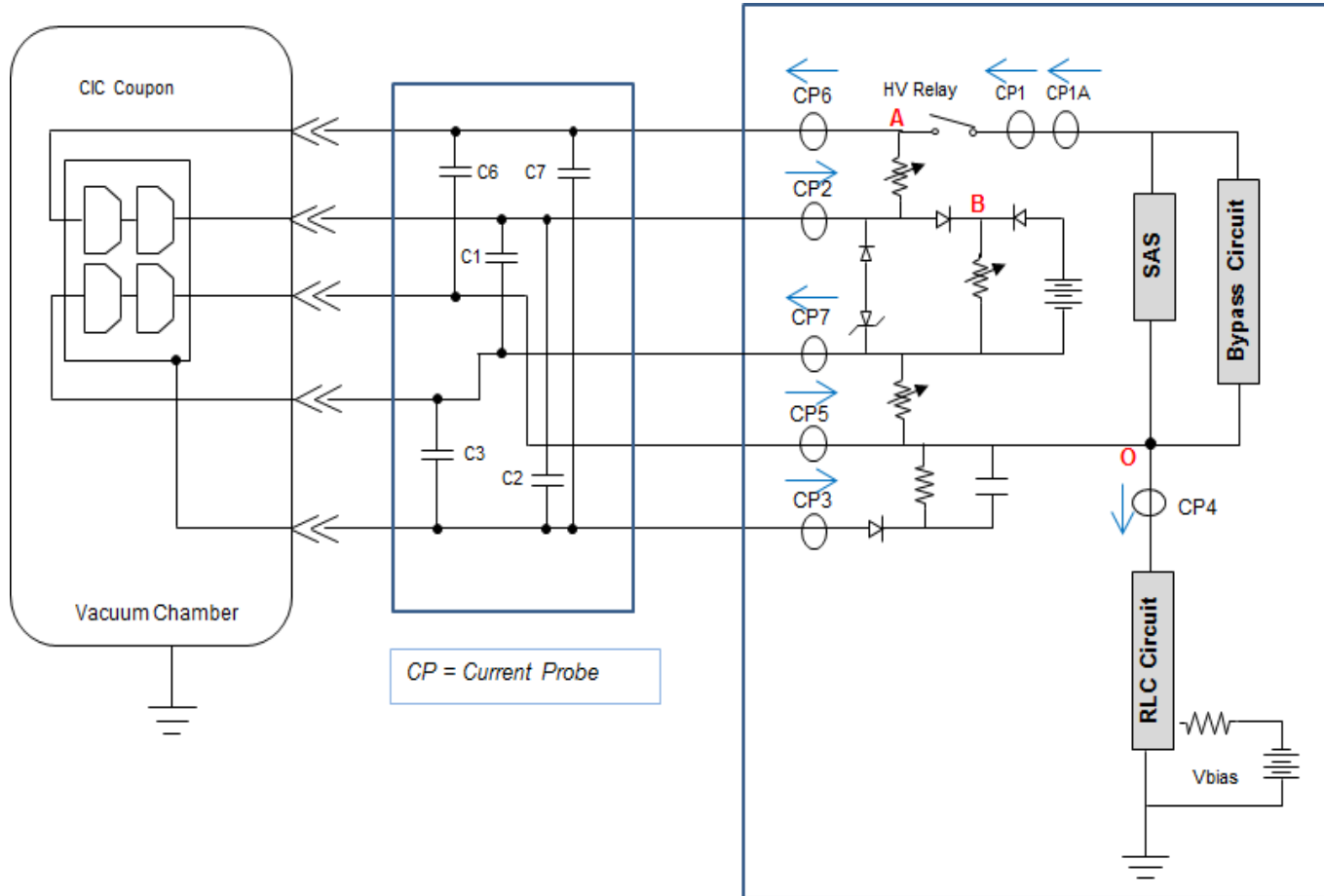

**Solar Array Simulator (SAS) power supply reacts quickly to load changes**

# Wire Coupon Passive Circuit Test Schematic

Signal wires were wrapped around the inductive current probes to increase current magnitude sensitivity

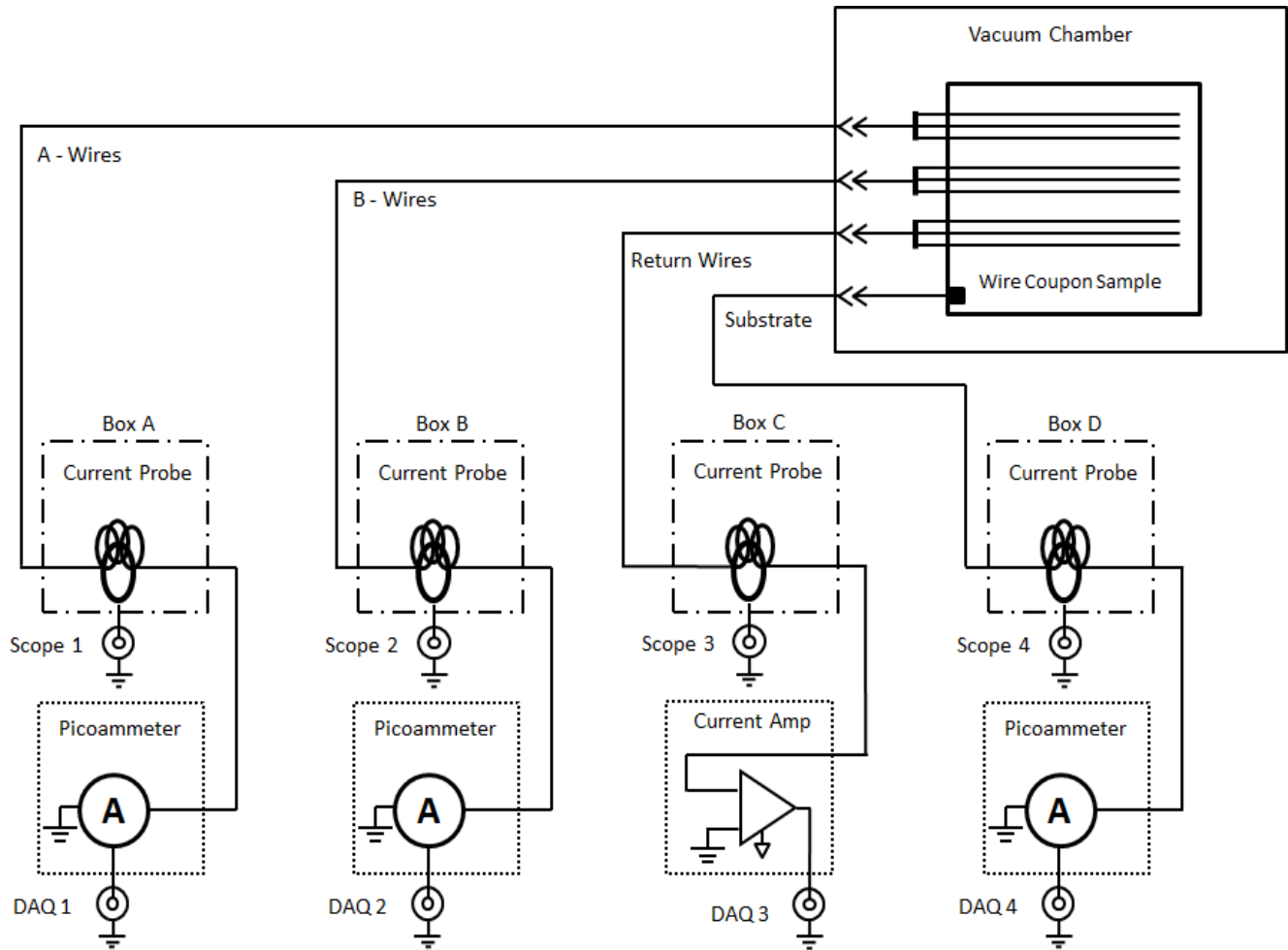

# Semi-rigid Coaxial Cable Sample Control Test

- Test of coaxial cable with DC block circuit that includes bleed resistors

