

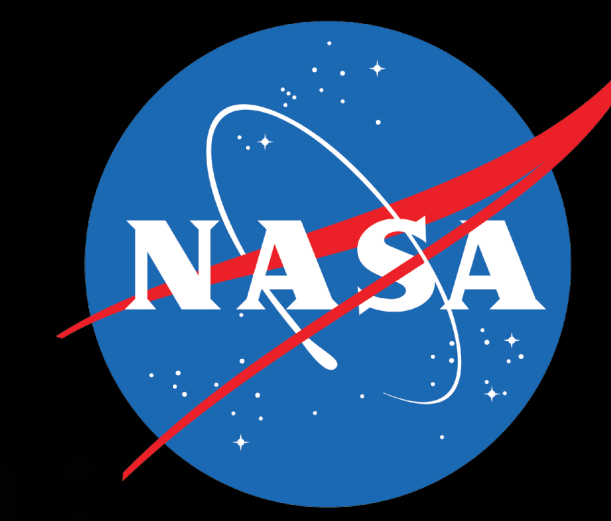

# Stratospheric Aerosol and Gas Experiment III on the International Space Station (SAGE III/ISS)



Joseph Gasbarre, Richard Walker, Michael Cisewski, Joseph Zawodny, Dianne Cheek, Brooke Thornton, NASA Langley Research Center, Hampton, VA

## History and Challenges

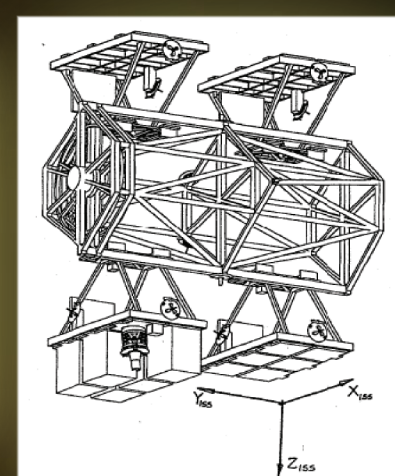
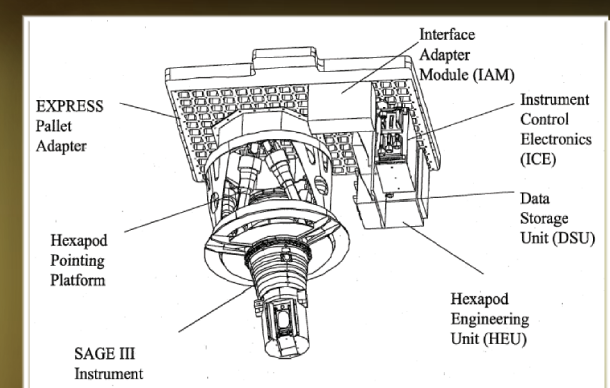

The Stratospheric Aerosol and Gas Experiment III on the International Space Station (SAGE III/ISS) mission will extend the SAGE data record from the ideal vantage point of the International Space Station (ISS). The ISS orbital inclination is ideal for SAGE measurements providing coverage between 70° north and 70° south latitude. The SAGE data record includes an extensively validated data set including aerosol optical depth data dating to the Stratospheric Aerosol and Gas Experiment (SAGE) in 1979. These and subsequent data records, notably from the SAGE II experiment launched on the Earth Radiation Budget Satellite in 1984 and the SAGE III experiment launched on the Russian Meteor-3M satellite in 2001, have supported a robust, long-term assessment of key atmospheric constituents. These scientific measurements provide the basis for the analysis of five of the nine critical constituents (aerosols, ozone (O<sub>3</sub>), nitrogen dioxide (NO<sub>2</sub>), water vapor (H<sub>2</sub>O), and air density using O<sub>2</sub>) identified in the U.S. National Plan for Stratospheric Monitoring. SAGE III on ISS was originally scheduled to fly on the ISS in the same timeframe as the Meteor-3M mission, but was postponed due to delays in ISS construction. The project was re-established in 2009.

## Accommodating SAGE on the ISS

When the SAGE III/ISS project was re-initiated, an extensive accommodation study was performed to assess possible locations on the ISS for SAGE III. The best balance of contamination environment, field of view, and use of heritage hardware was determined to be mounting SAGE III on the Expedite the Processing of Experiments to the Space Station (ExPRESS) Logistics Carrier 4 (ELC-4). While this is the most ideal site for SAGE III with regard to science return, it did require a novel approach to the mission concept. Thus, the mission consists of two independent payloads that are flown to the ISS separately and combined robotically on-orbit in the final configuration. The Instrument Payload (IP) is based on the existing SAGE III flight Instrument Assembly (IA) and an existing European Space Agency provided Hexapod course pointing system, both originally developed for flight on the ISS. Other components of the IP include the robotically installable ExPRESS Payload Adapter (ExPA), a new avionics unit called the Interface Adapter Module (IAM) with an integrated Solid State Memory Card (SSMC), two Contamination Monitoring Packages (CMP), and a Disturbance Monitoring Package (DMP). The other payload is the Nadir Viewing Platform (NVP) Payload which replicated the ISS mechanical and electrical interface at 90 degrees from its originally intended interface on ELC-4.

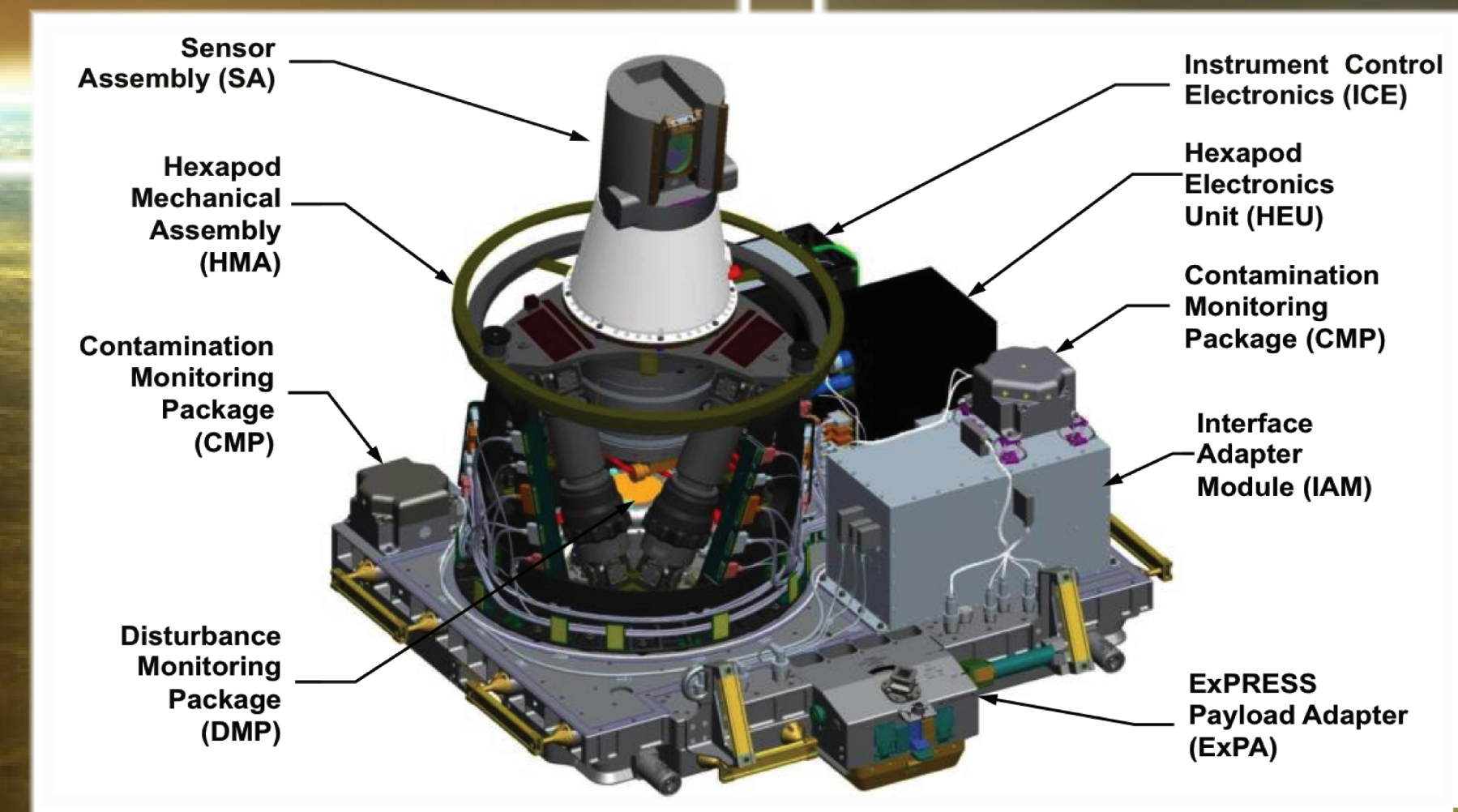
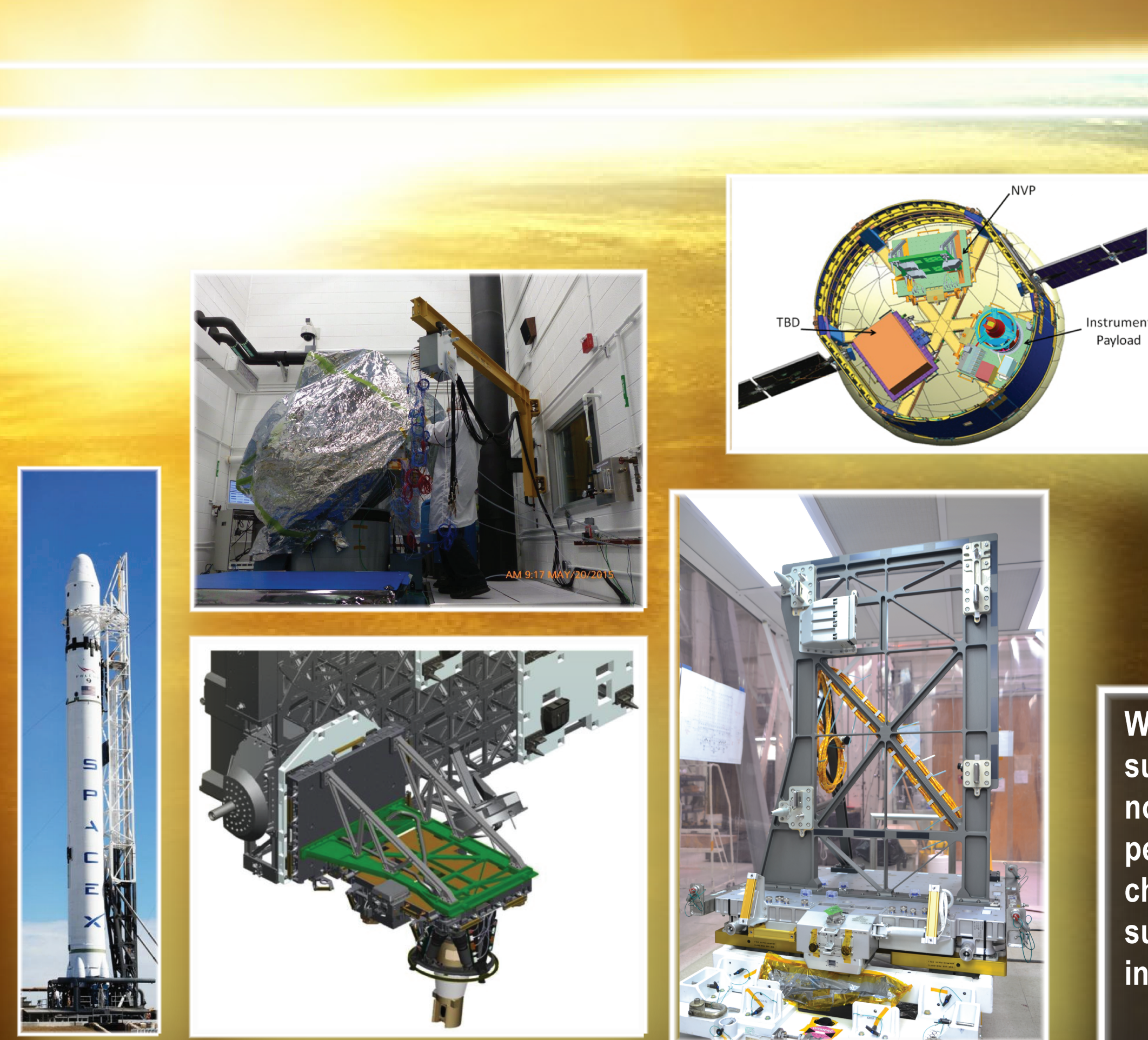
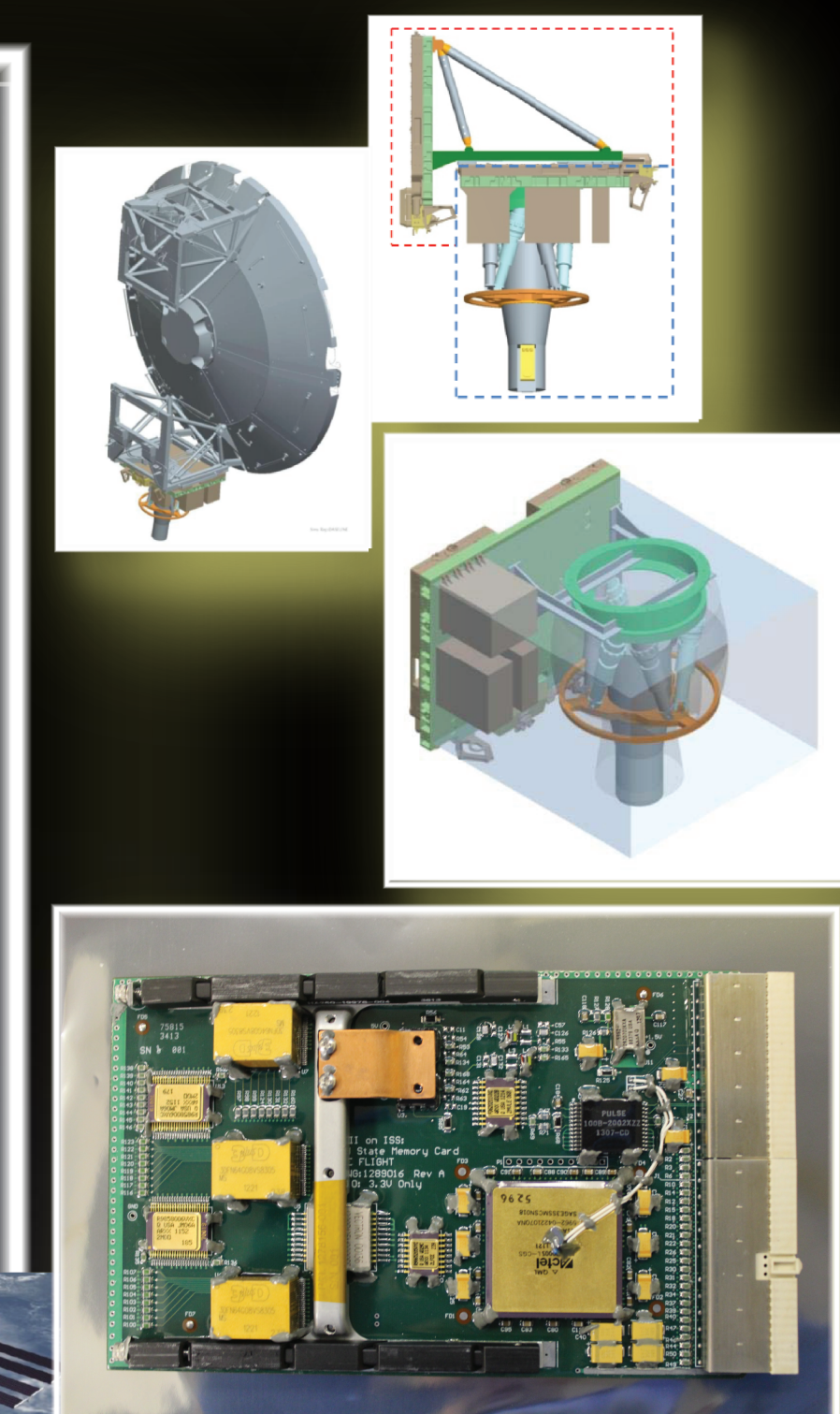

## Design, Build, Test, and Fly

With the mission concept set, detailed design and analysis of the two payloads and their subsystems as conceived in the concept commenced. During this phase, several obstacles not originally foreseen during the trade study were encountered. With Project team perseverance and excellent collaboration with the ISS Program, the team overcame these challenges, and SAGE III on ISS was able to complete fabrication, integration, and testing of its subsystems earlier this year. The project is currently in the middle of its payload-level integration and test phase with a planned delivery for launch in early 2016 on the SpaceX Dragon Cargo Resupply System - Flight 10.

