



US009336421B1

(12) **United States Patent**
Fink et al.

(10) **Patent No.:** **US 9,336,421 B1**
(45) **Date of Patent:** **May 10, 2016**

(54) **SYSTEM AND METHOD FOR
RFID-ENABLED INFORMATION
COLLECTION**

(71) Applicant: **The United States of America as
represented by the Administrator of
the National Aeronautics and Space
Administration, Washington, DC (US)**

(72) Inventors: **Patrick W. Fink, Missouri City, TX
(US); Gregory Y. Lin, Friendswood, TX
(US); Timothy F. Kennedy, Sugar Land,
TX (US); Phong H. Ngo, Friendswood,
TX (US); Diane Byerly, Seabrook, TX
(US)**

(73) Assignee: **The United States of America as
represented by the Administrator of
the National Aeronautics and Space
Administration, Washington, DC (US)**

(*) Notice: Subject to any disclaimer, the term of this
patent is extended or adjusted under 35
U.S.C. 154(b) by 1 day.

(21) Appl. No.: **14/549,159**

(22) Filed: **Nov. 20, 2014**

Related U.S. Application Data

(62) Division of application No. 13/790,591, filed on Mar.
8, 2013, now Pat. No. 8,933,789.

(51) **Int. Cl.**
H04Q 5/22 (2006.01)
G06K 7/10 (2006.01)
G01F 23/284 (2006.01)
G06K 19/077 (2006.01)

(52) **U.S. Cl.**
CPC **G06K 7/10316** (2013.01); **G01F 23/2845**
(2013.01); **G06K 19/07758** (2013.01)

(58) **Field of Classification Search**

CPC G01F 23/2845; G06K 19/0716; G06K
19/0723; G06K 19/07758; A47F 1/126;
G06Q 10/087
USPC 340/10.1; 235/492; 342/124
See application file for complete search history.

(56) **References Cited**

U.S. PATENT DOCUMENTS

6,184,818	B1	2/2001	Meinel
6,269,285	B1	7/2001	Mignault
6,539,280	B1	3/2003	Valiulis et al.
7,113,125	B2	9/2006	Le Sesne
7,644,889	B2	1/2010	Johnson
8,260,456	B2	9/2012	Siegel et al.
8,695,878	B2	4/2014	Burnside et al.
8,712,585	B2	4/2014	Bruck et al.

(Continued)

Primary Examiner — John A Tweel, Jr.

(74) *Attorney, Agent, or Firm* — Kurt G. Hammerle

(57) **ABSTRACT**

Methods, apparatuses and systems for radio frequency identification (RFID)-enabled information collection are disclosed, including an enclosure, a collector coupled to the enclosure, an interrogator, a processor, and one or more RFID field sensors, each having an individual identification, disposed within the enclosure. In operation, the interrogator transmits an incident signal to the collector, causing the collector to generate an electromagnetic field within the enclosure. The electromagnetic field is affected by one or more influences. RFID sensors respond to the electromagnetic field by transmitting reflected signals containing the individual identifications of the responding RFID sensors to the interrogator. The interrogator receives the reflected signals, measures one or more returned signal strength indications ("RSSI") of the reflected signals and sends the RSSI measurements and identification of the responding RFID sensors to the processor to determine one or more facts about the influences. Other embodiments are also described.

10 Claims, 25 Drawing Sheets

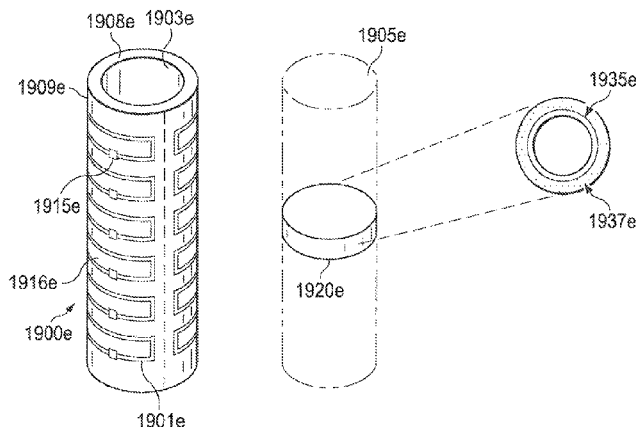

US 9,336,421 B1

Page 2

(56)

References Cited

U.S. PATENT DOCUMENTS

8,812,378	B2 *	8/2014	Swafford et al.	705/28	2005/0017895	A1	1/2005	Andersson	
8,933,789	B1 *	1/2015	Fink et al.	340/10.1	2006/0145863	A1	7/2006	Martin et al.	
8,985,468	B1 *	3/2015	Fink et al.	235/492	2007/0254080	A1	11/2007	Schackmuth et al.	
9,031,689	B1 *	5/2015	Fink et al.	700/236	2007/0268139	A1	11/2007	Sweeney, II	
					2010/0060457	A1	3/2010	Burnside et al.	
					2012/0091162	A1 *	4/2012	Overhultz et al.	221/1

* cited by examiner

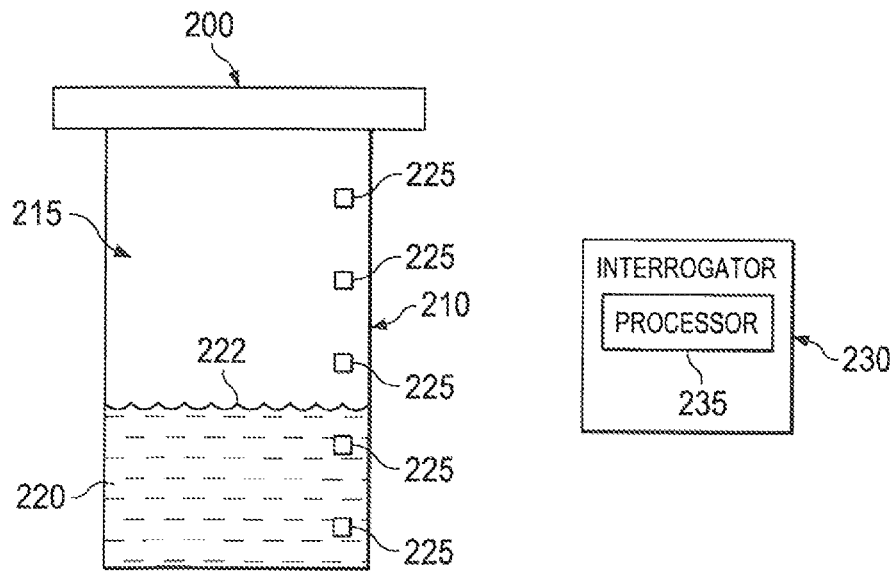
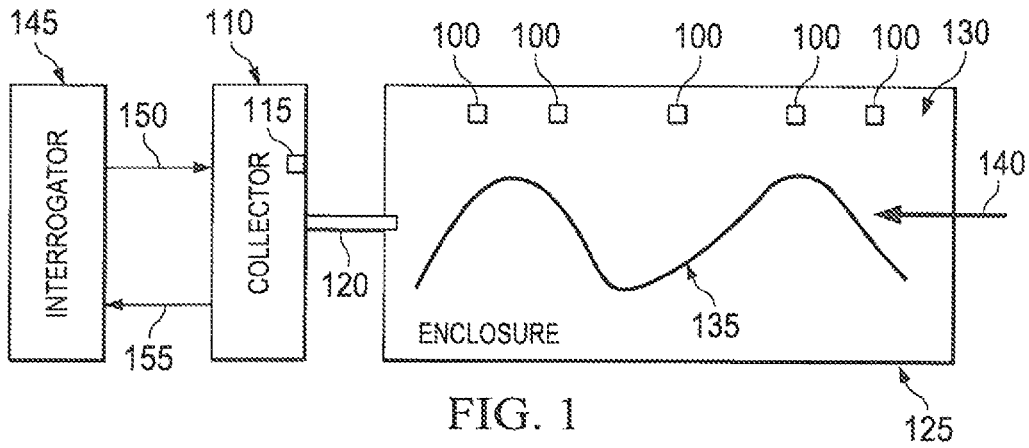

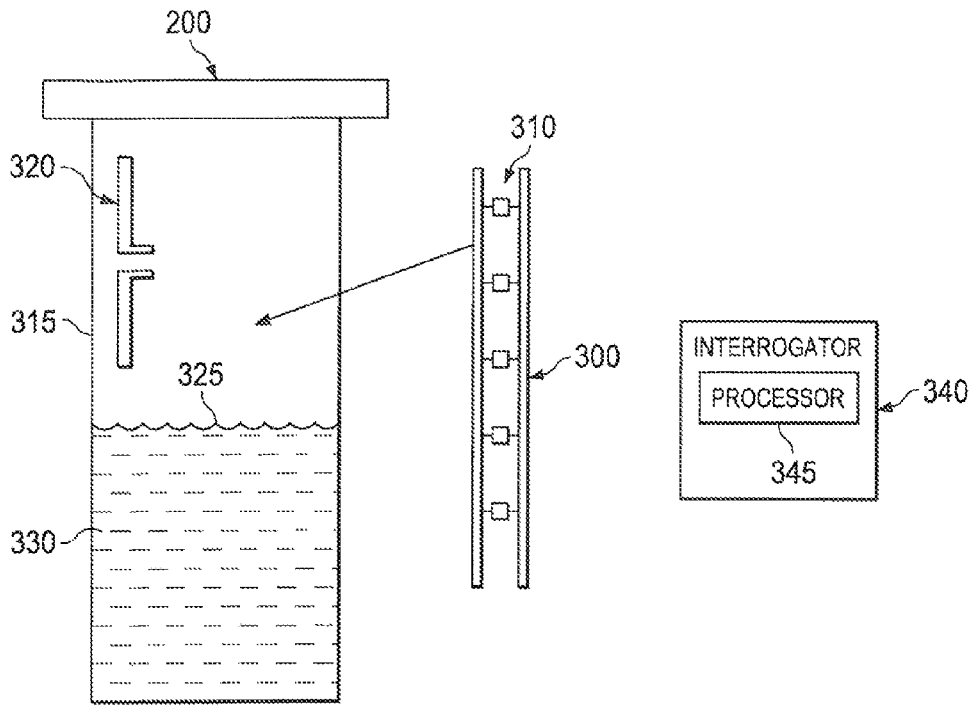

FIG. 3

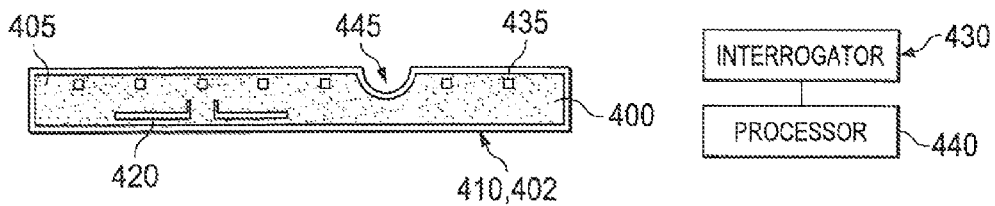

FIG. 4

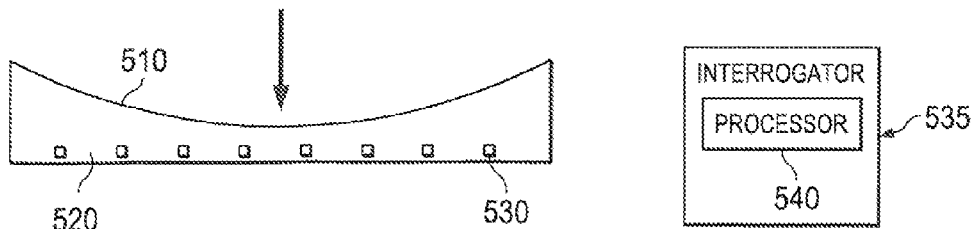

FIG. 5

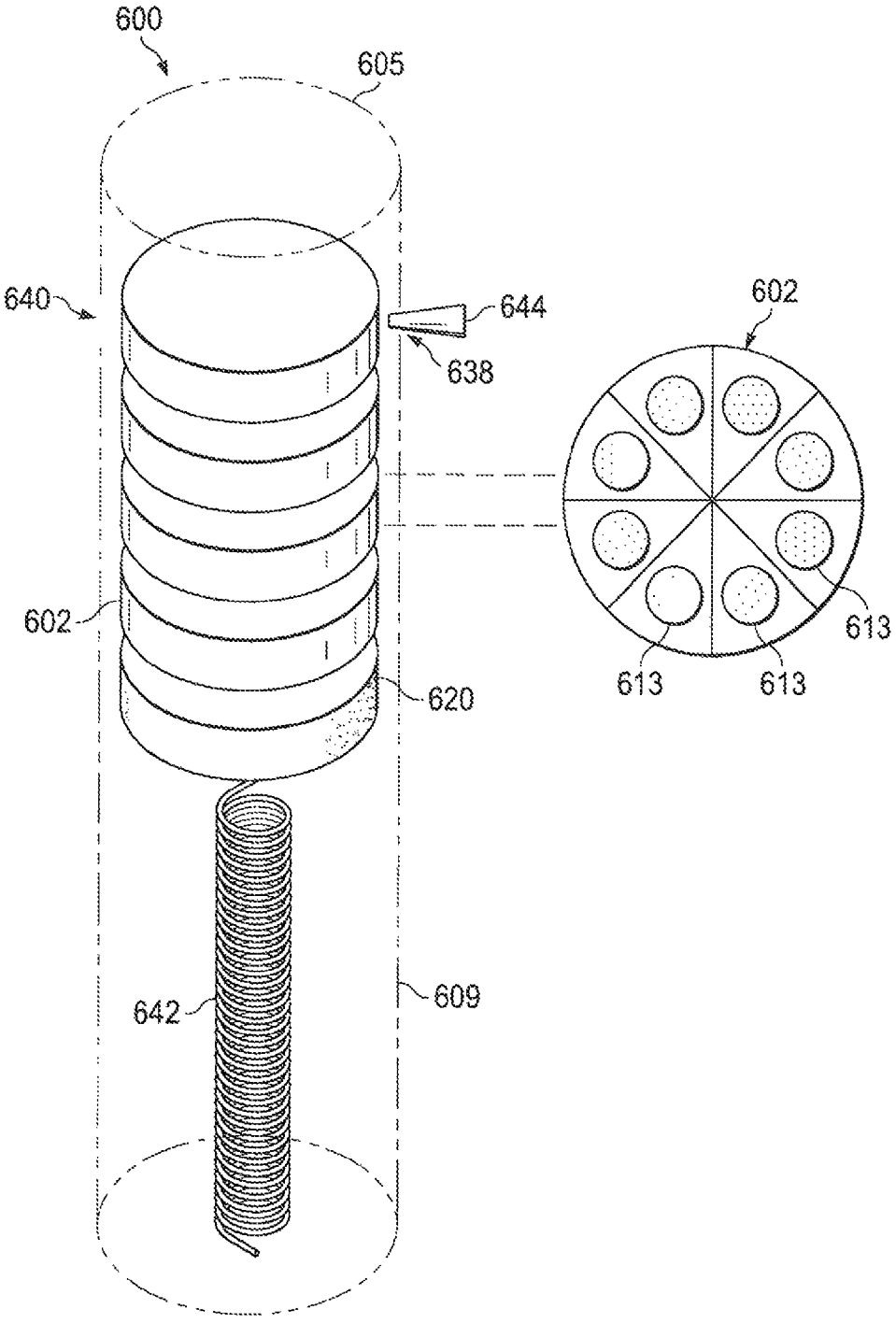

FIG. 6

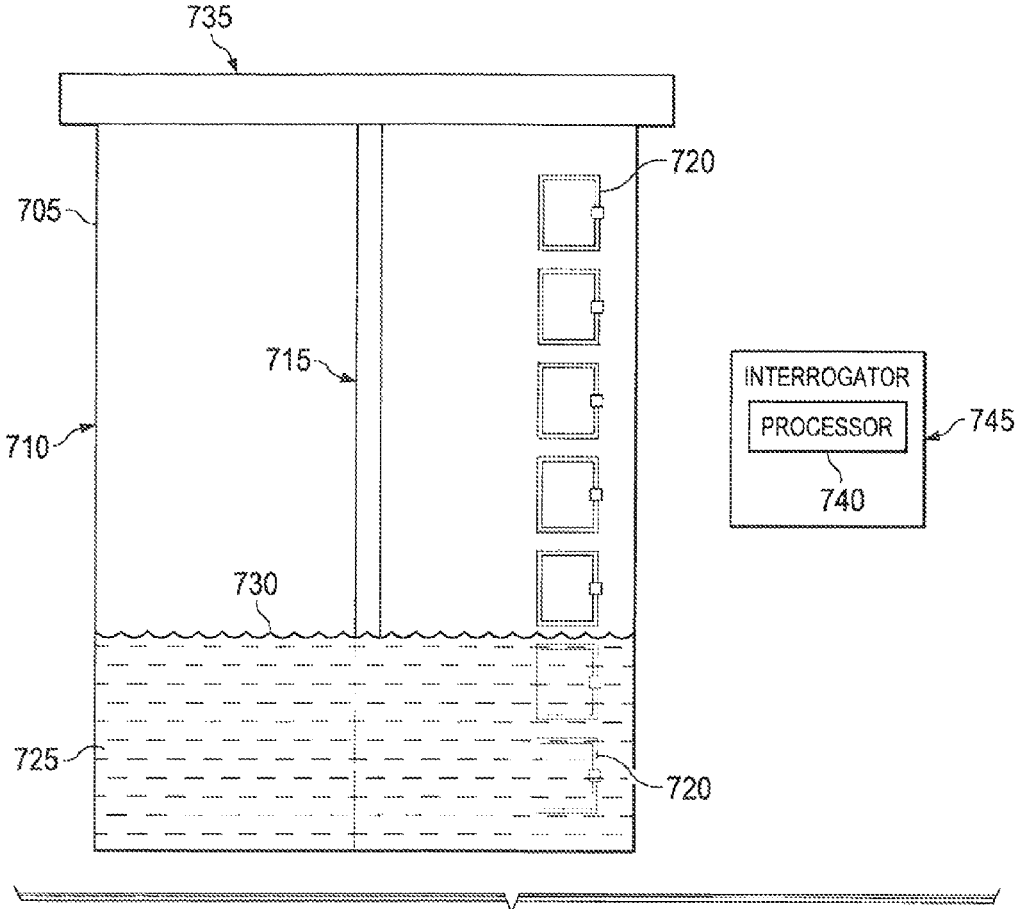
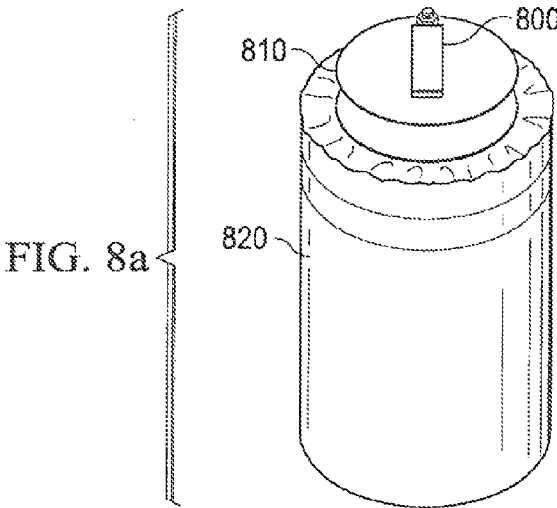

FIG. 7



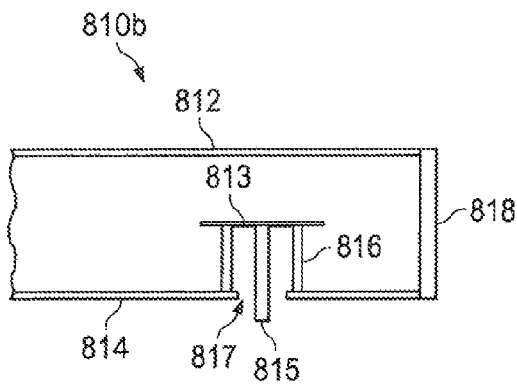

FIG. 8b

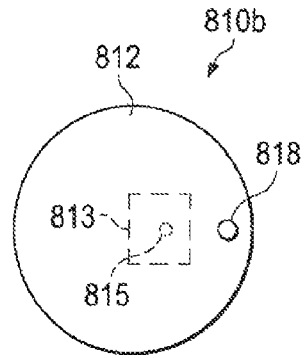

FIG. 8c

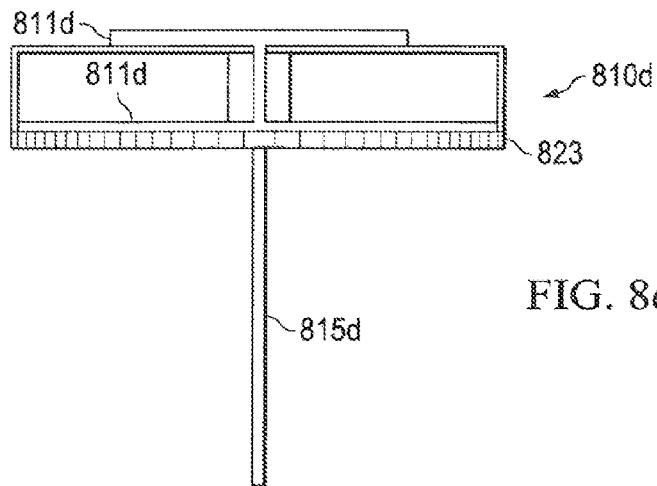

FIG. 8d

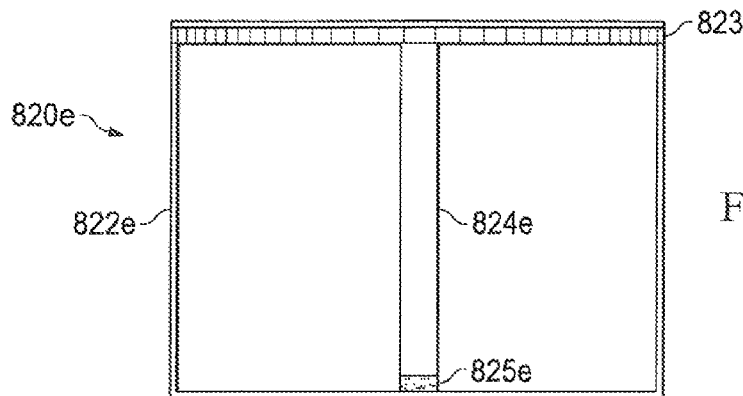

FIG. 8e

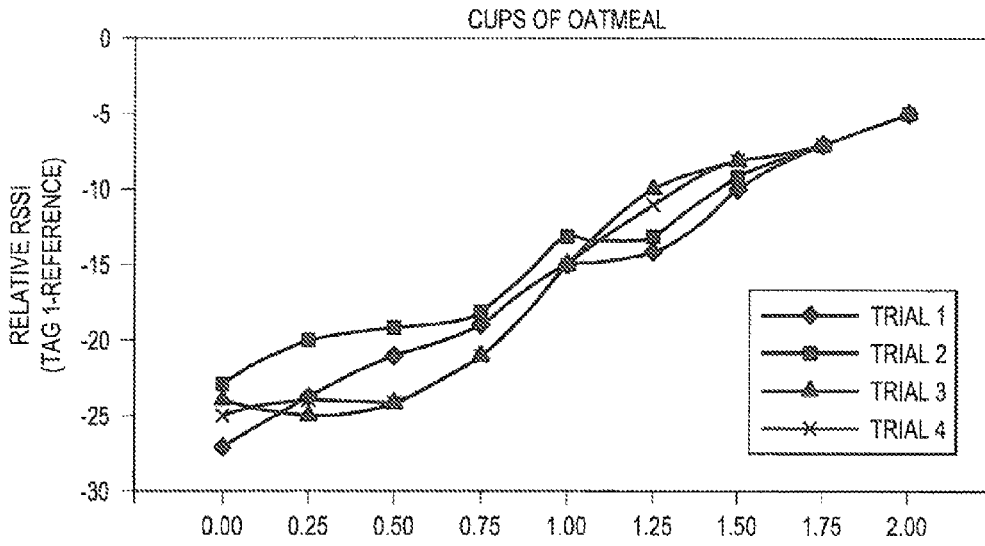

FIG. 9

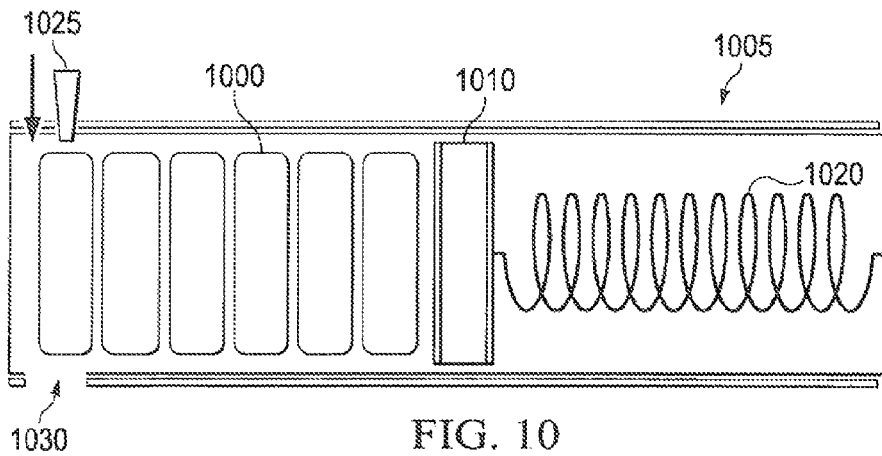
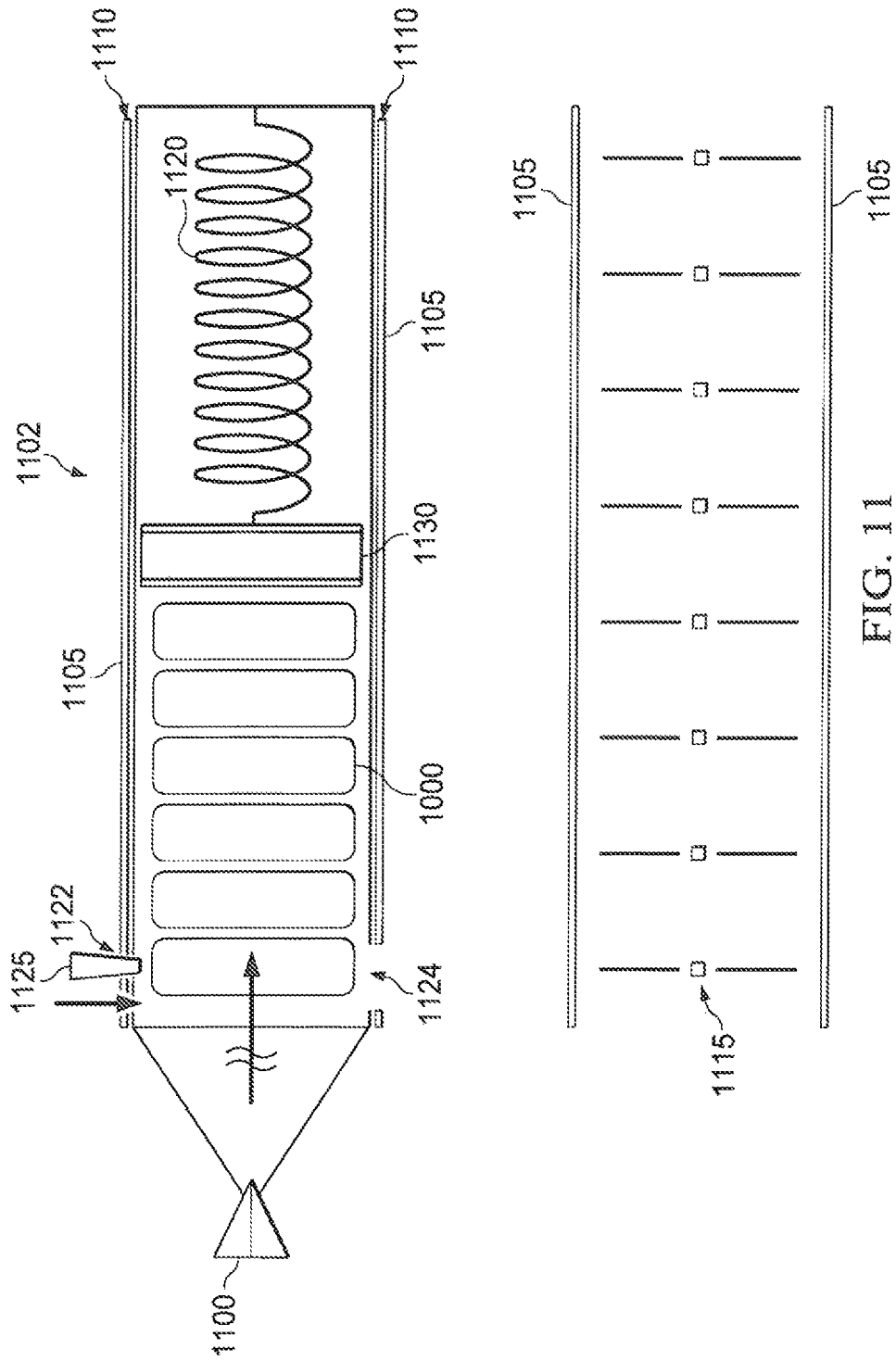

FIG. 10



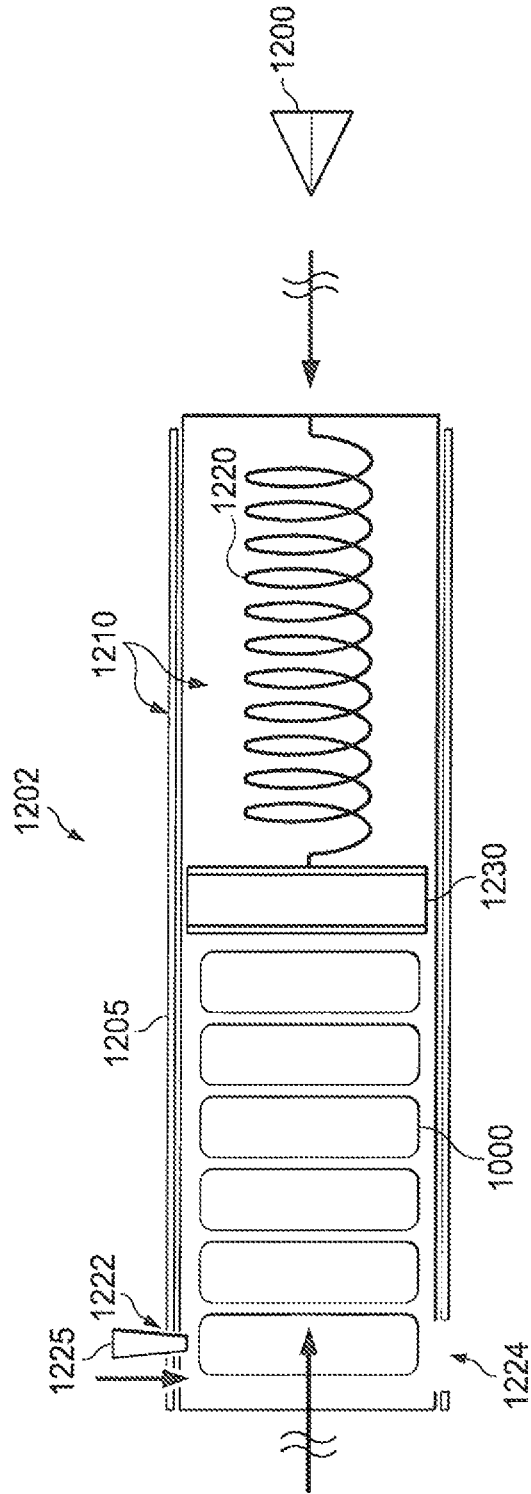

FIG. 12

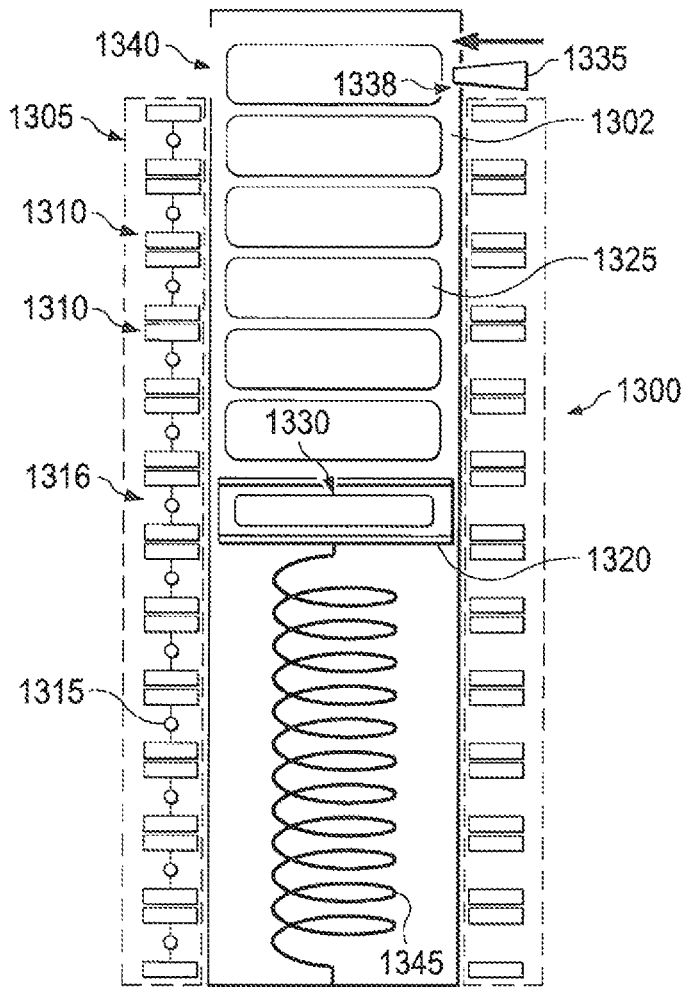

FIG. 13

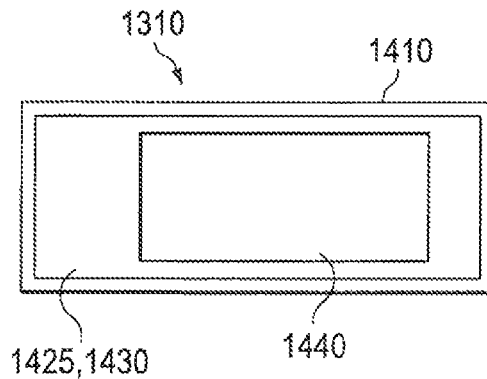

FIG. 14

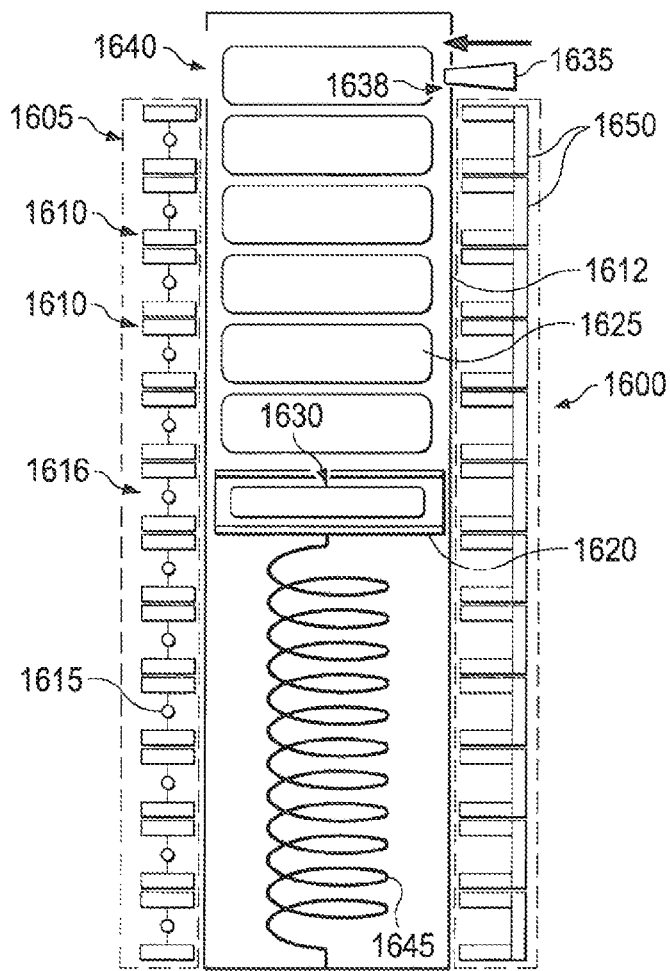
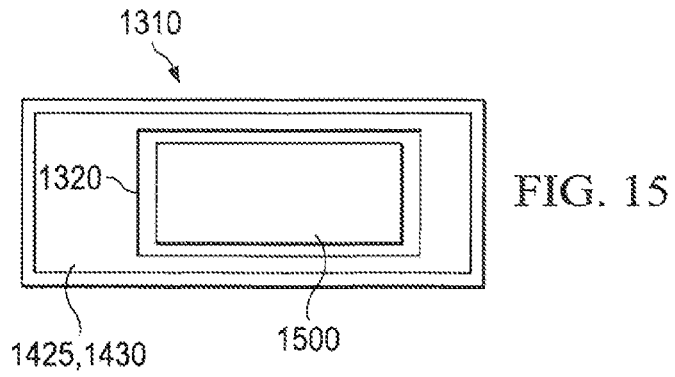

FIG. 16

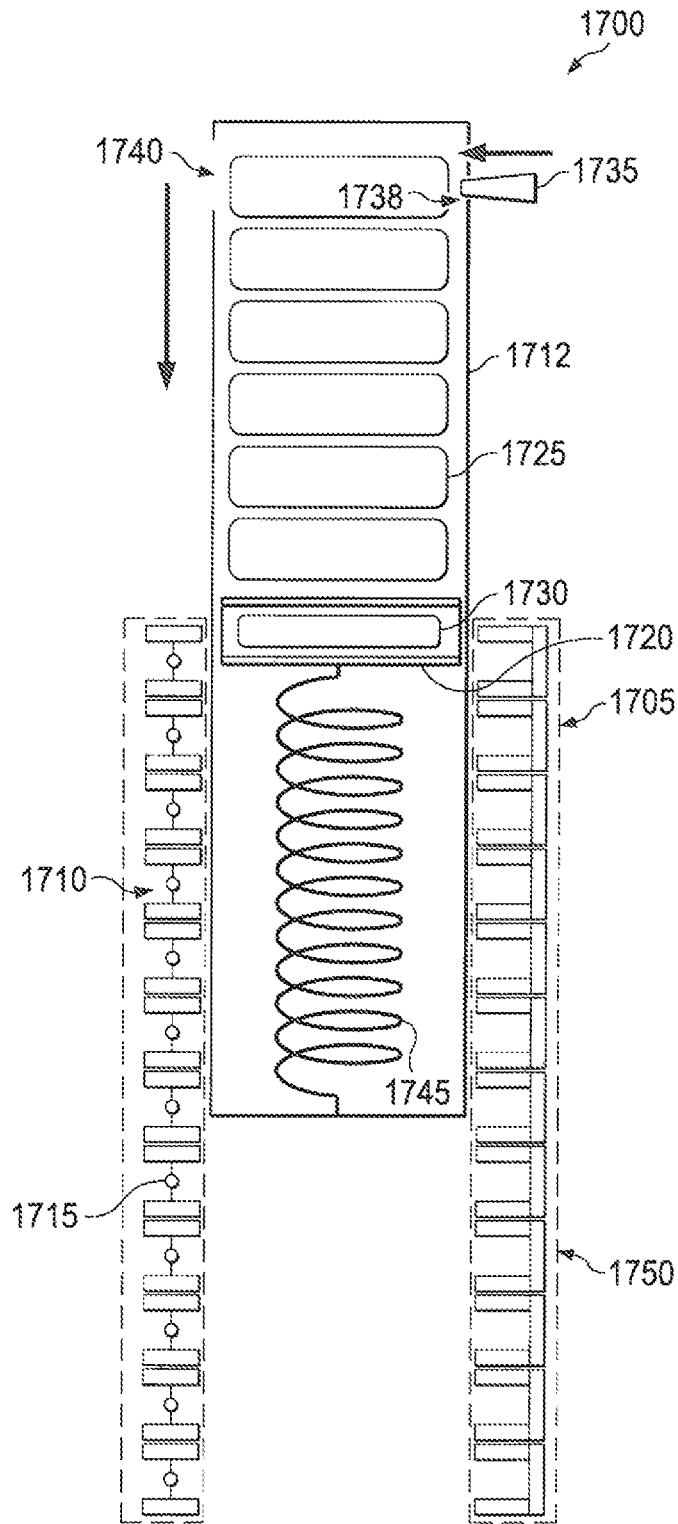

FIG. 17

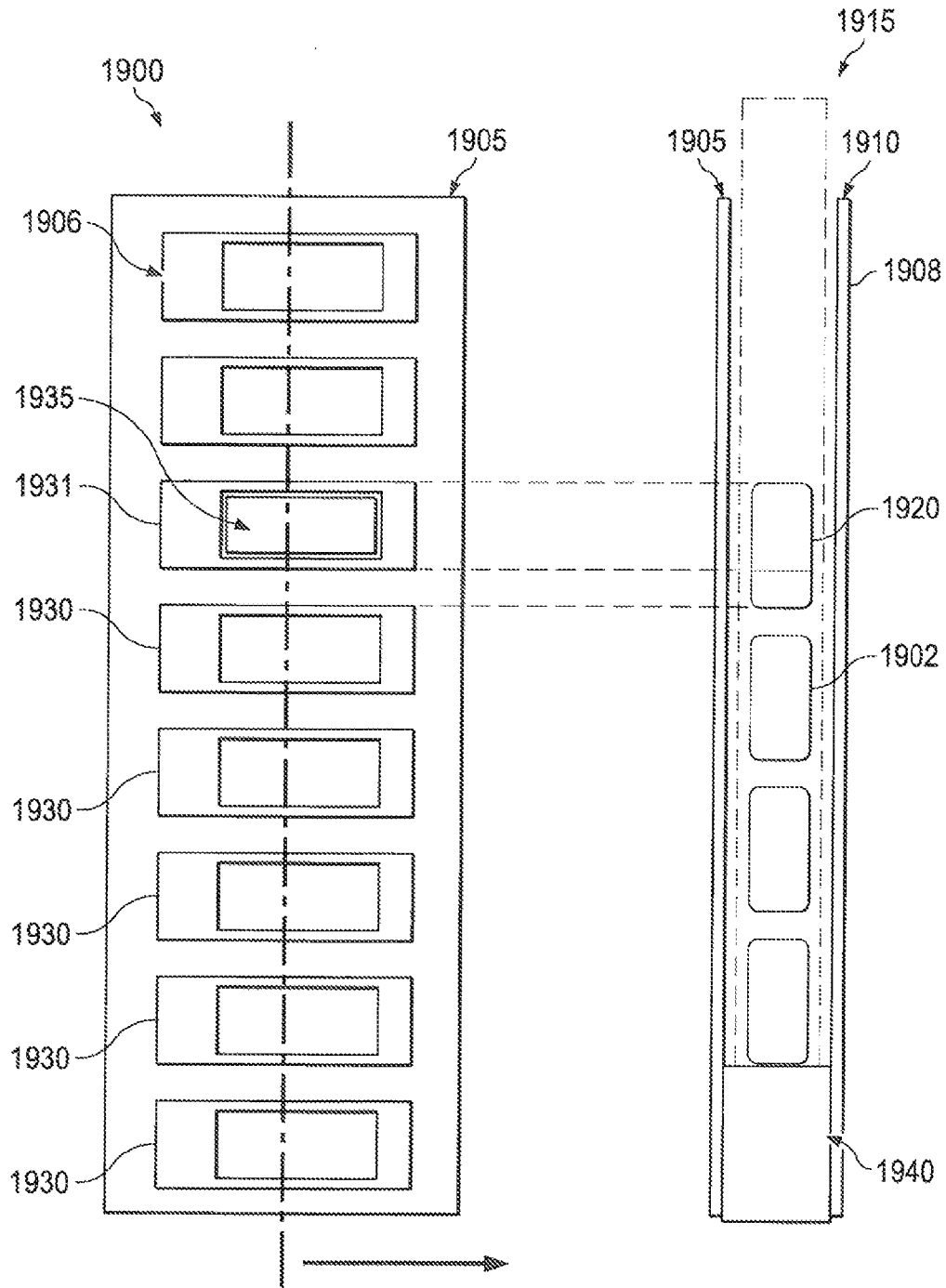

FIG. 19a

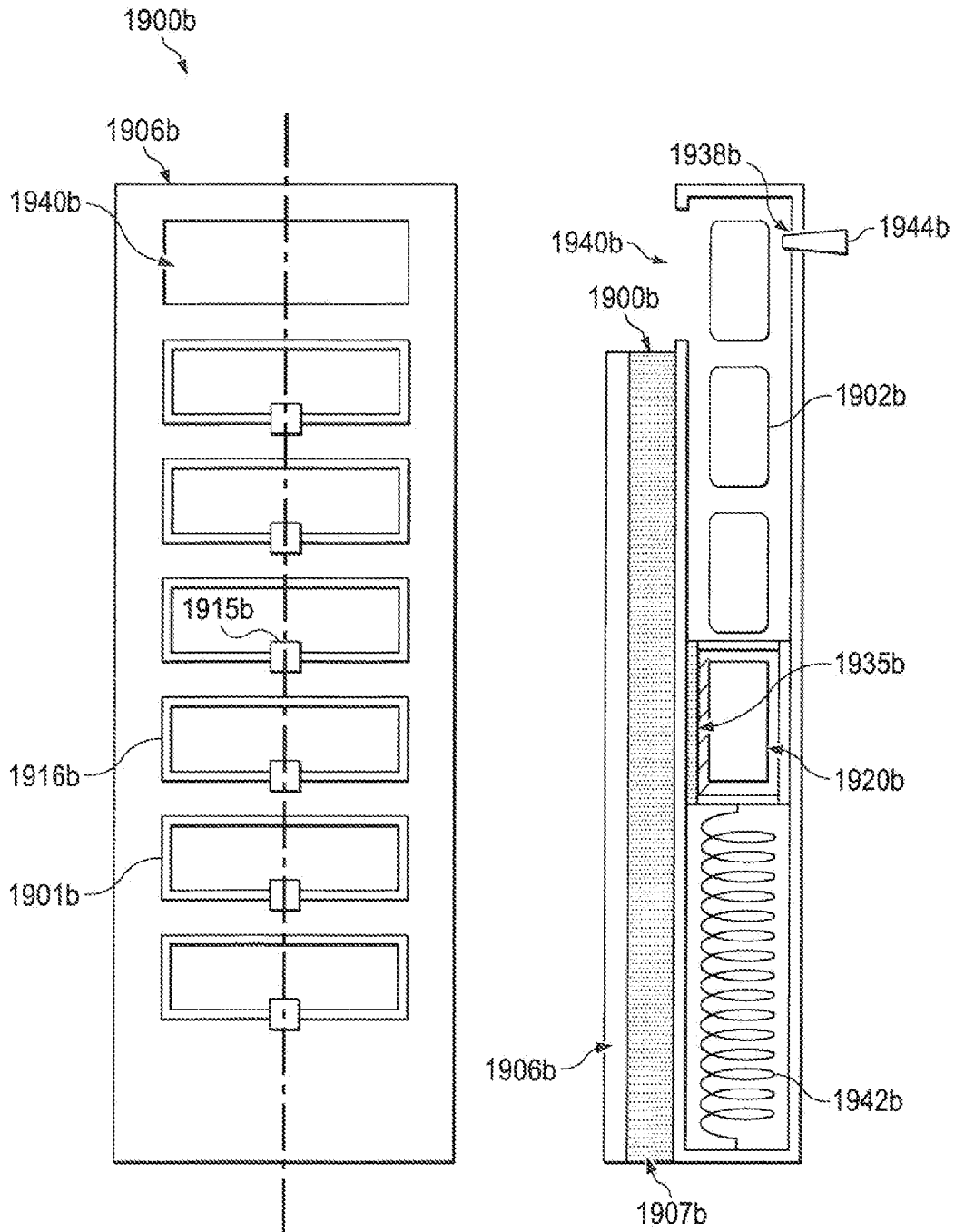

FIG. 19b

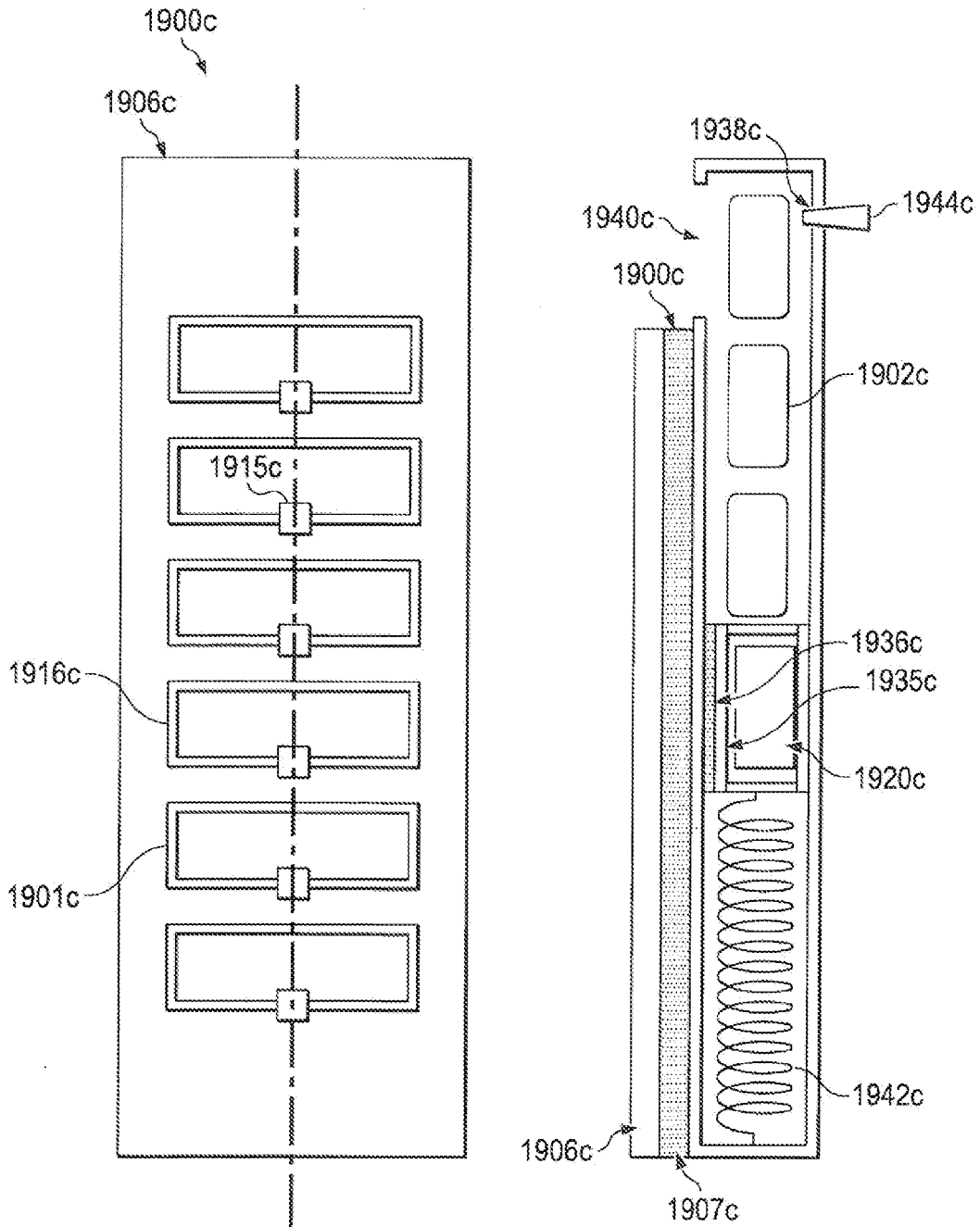

FIG. 19c

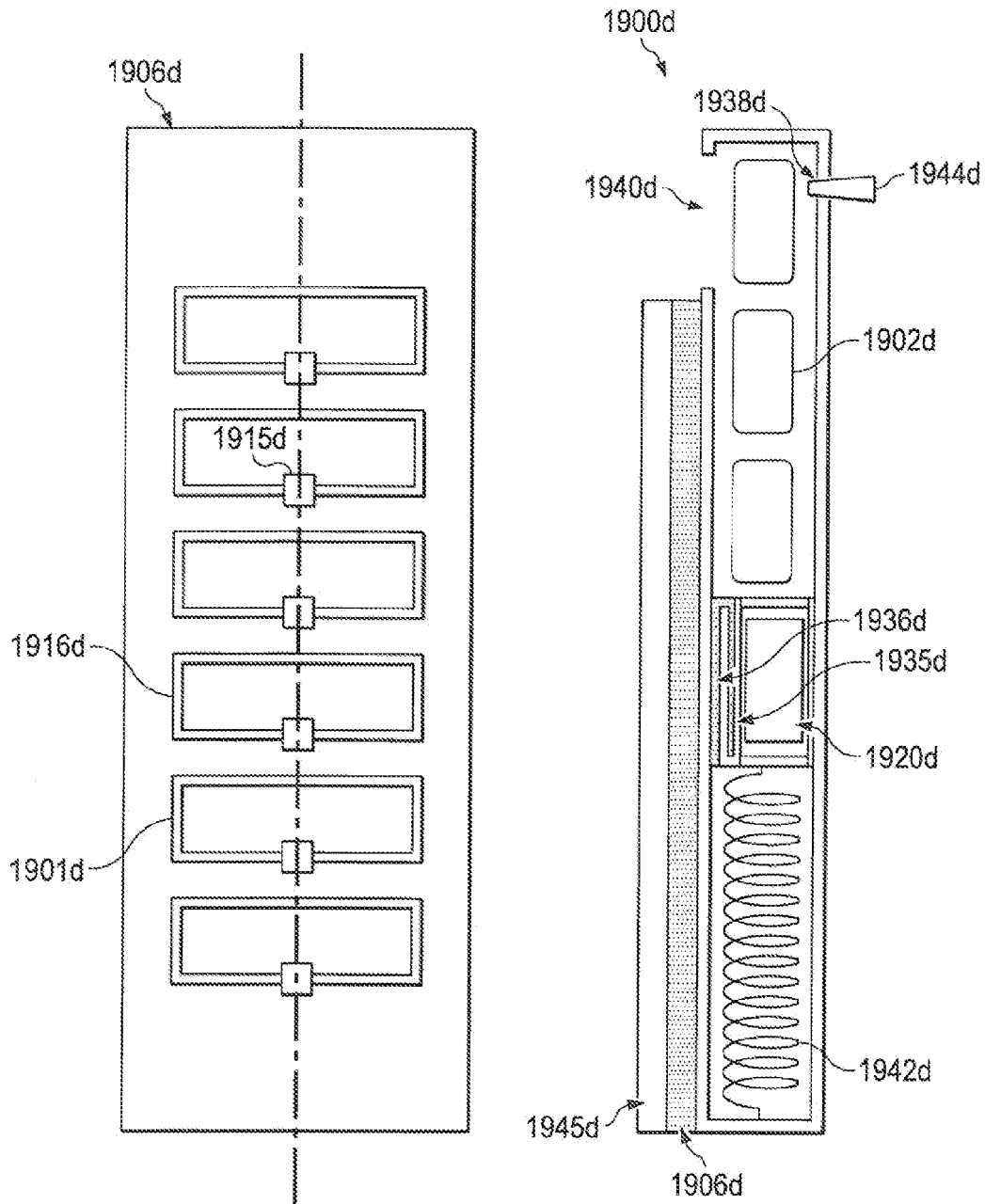
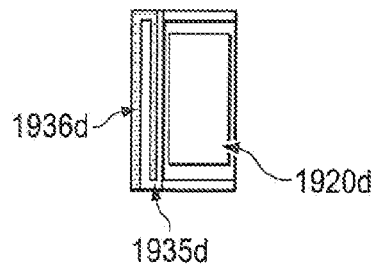

FIG. 19d



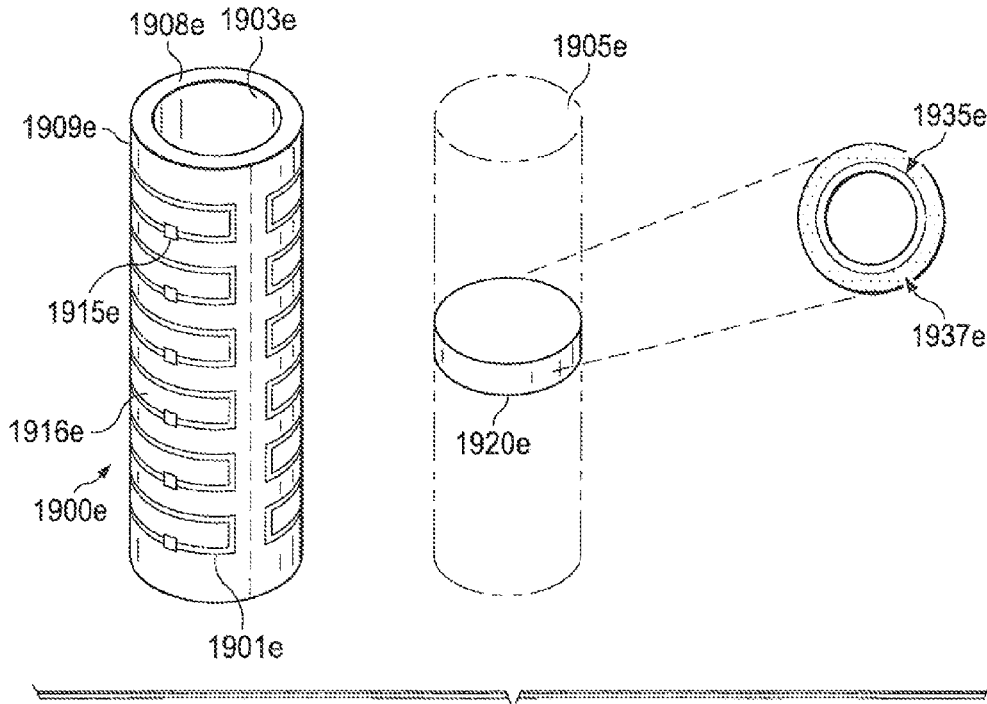

FIG. 19e

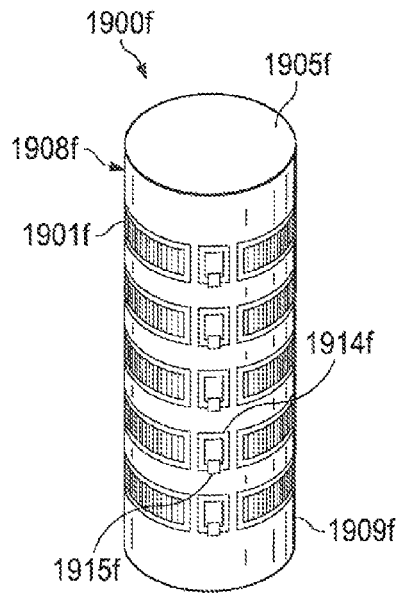

FIG. 19f

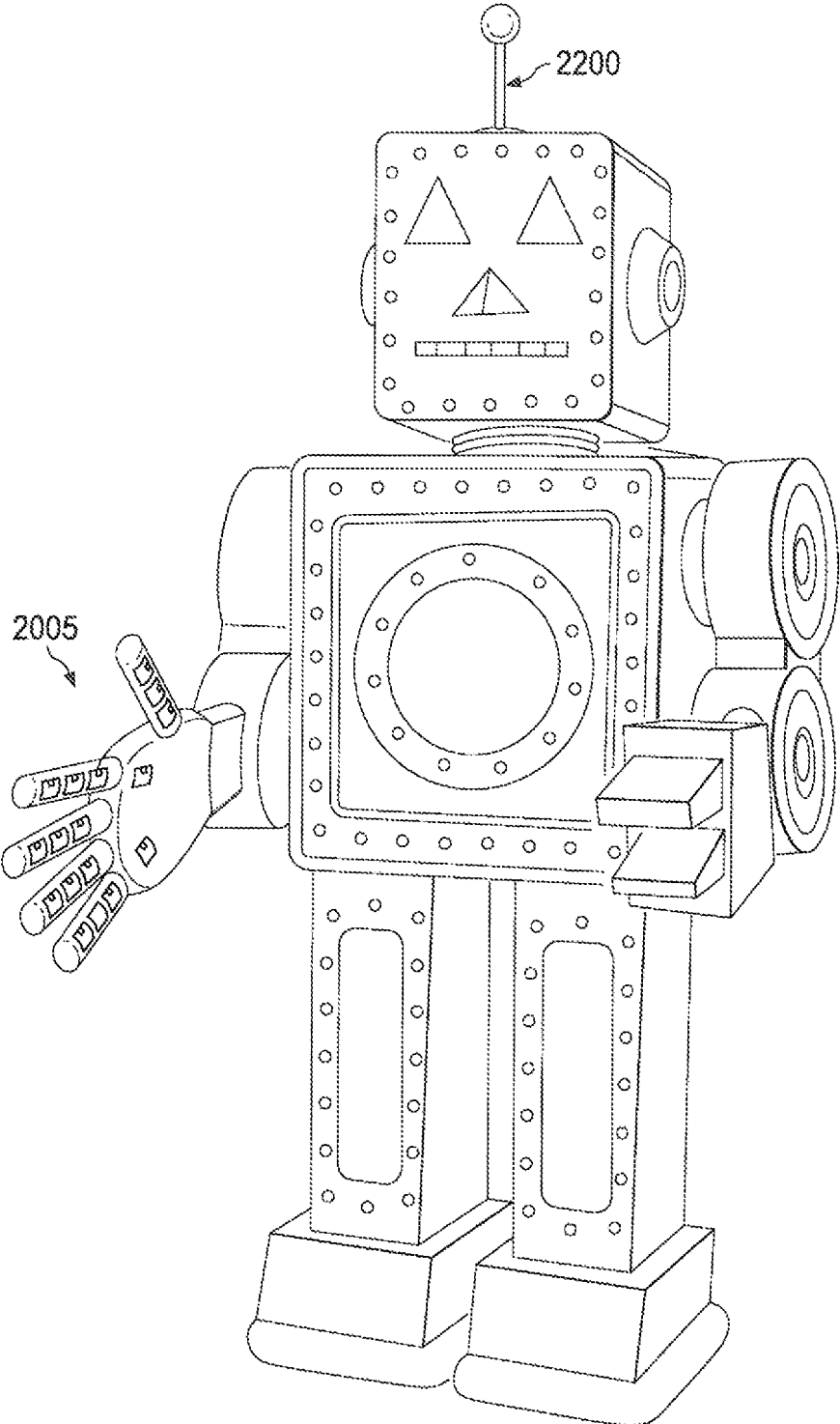
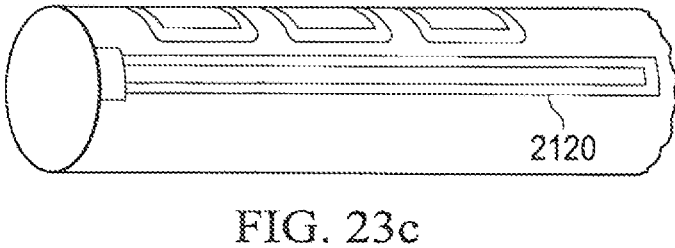
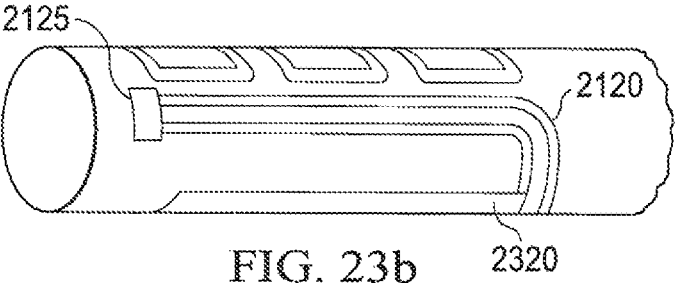
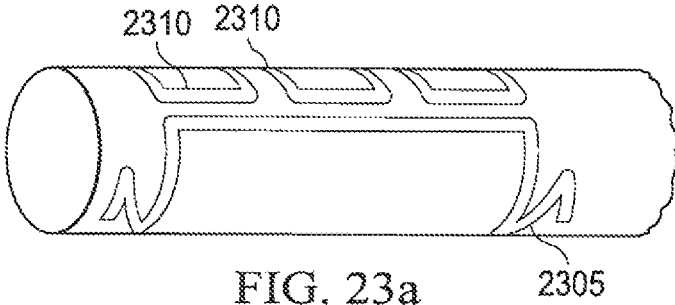

FIG. 22



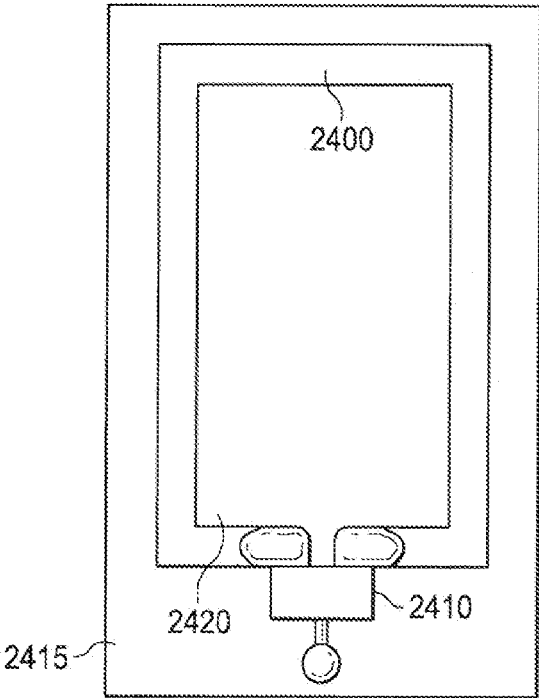

FIG. 24

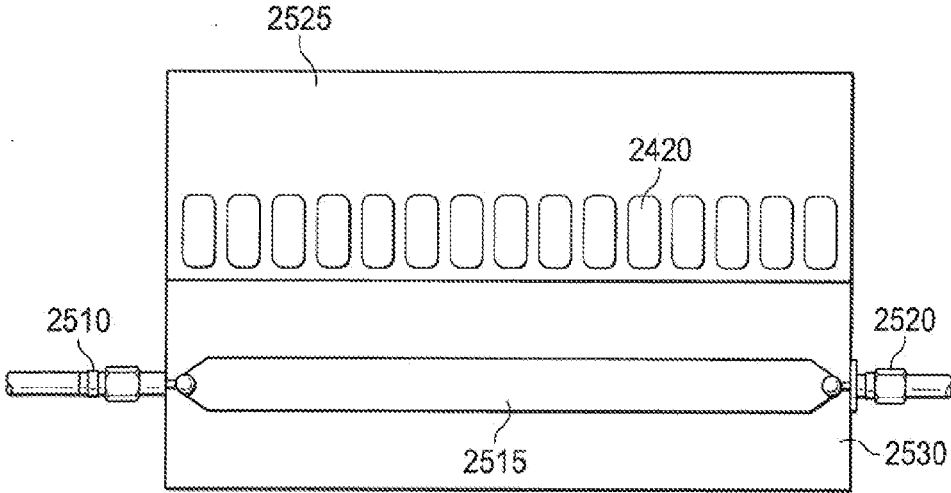

FIG. 25

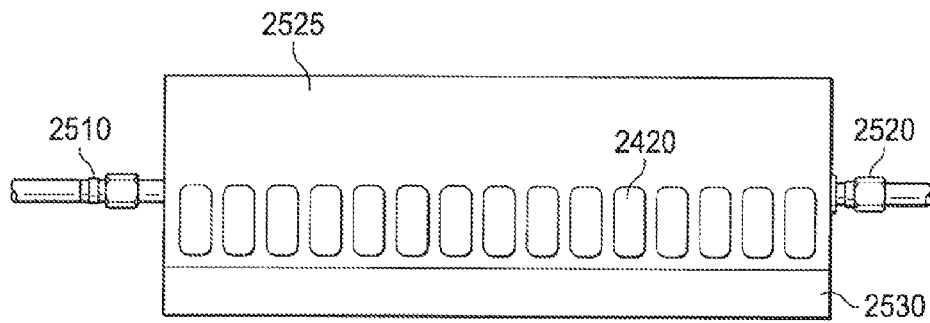

FIG. 26

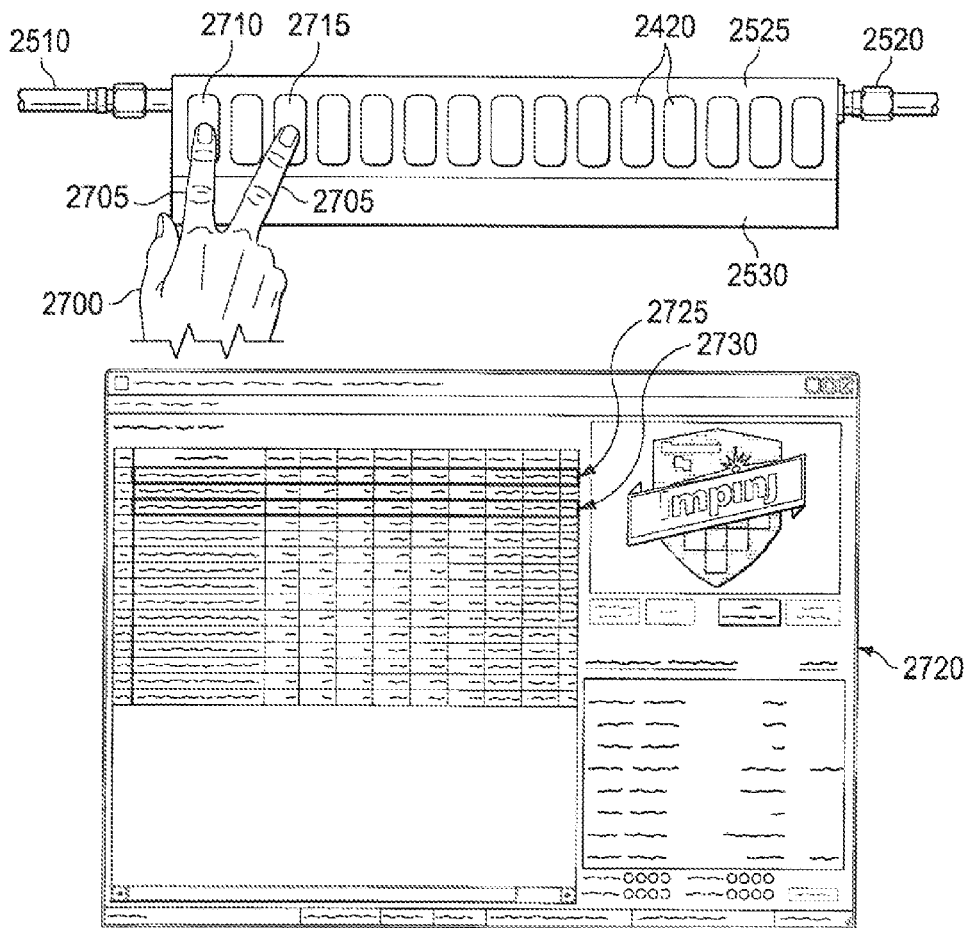

FIG. 27

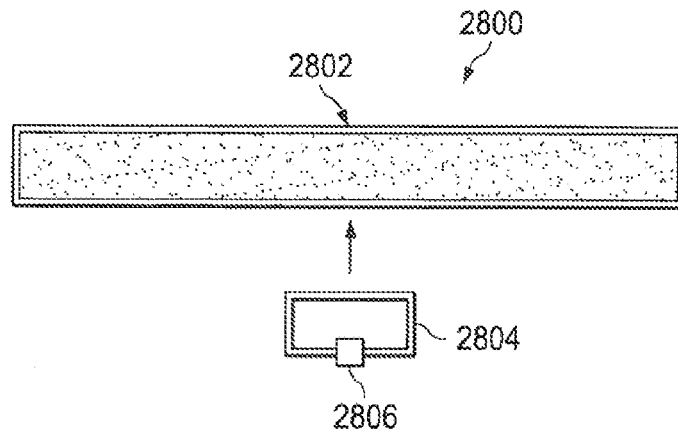

FIG. 28

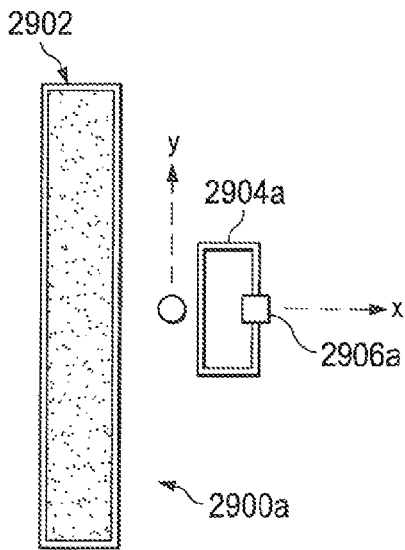

FIG. 29a

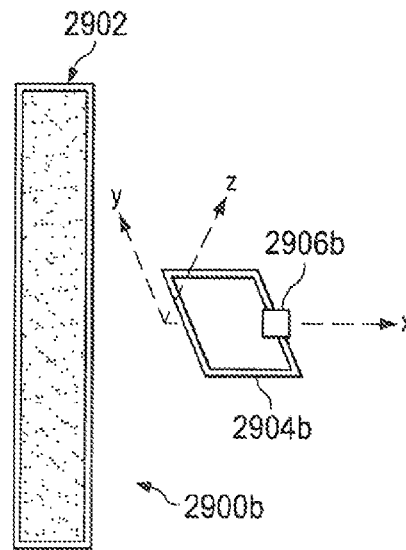

FIG. 29b

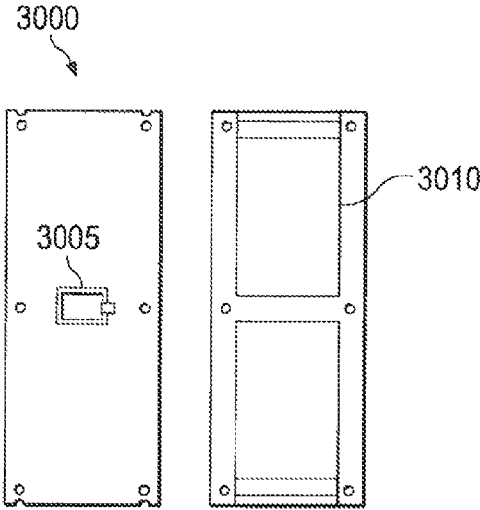

FIG. 30a

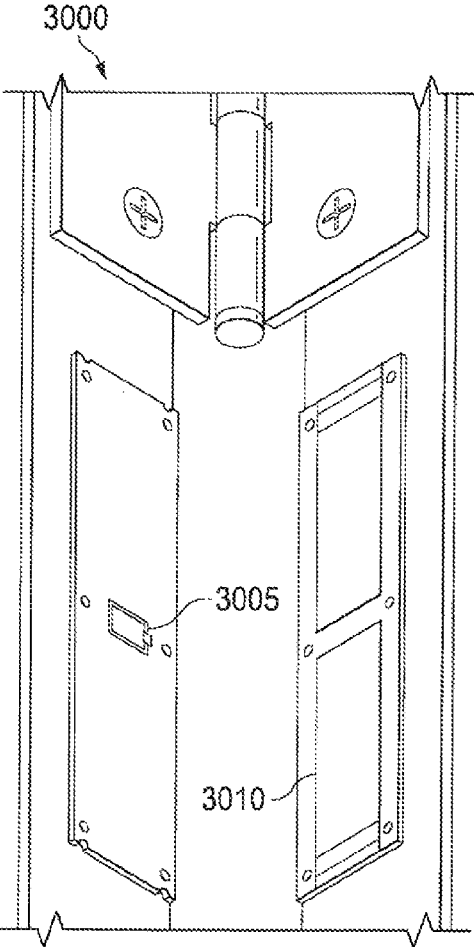

FIG. 30b

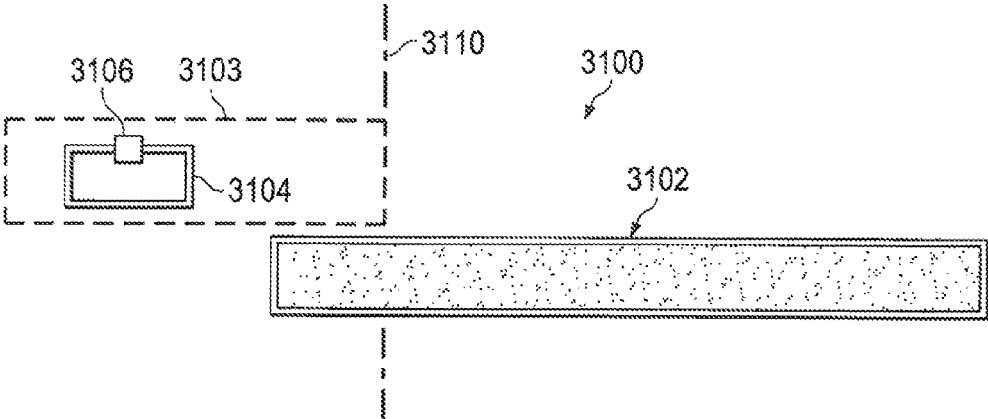

FIG. 31a

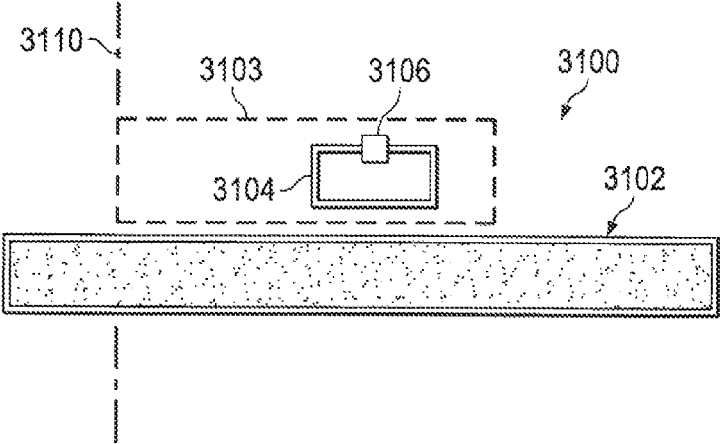

FIG. 31b

1

SYSTEM AND METHOD FOR RFID-ENABLED INFORMATION COLLECTION

II. CROSS REFERENCE TO RELATED APPLICATION

This is a divisional application of application Ser. No. 13/790,591 filed on Mar. 8, 2013.

I. ORIGIN OF THE INVENTION

The invention described herein was made by employees of the United States Government and may be manufactured and used by or for the Government of the United States of America for governmental purposes without the payment of any royalties thereon or therefor.

III. FIELD OF THE DISCLOSURE

The present disclosure relates generally to radio frequency identification (RFID) systems, methods, and apparatuses. More particularly, the disclosure relates to systems, methods and apparatuses for RFID-enabled information collection.

IV. BACKGROUND OF THE DISCLOSURE

The embodiments described herein relate generally to the field of radio frequency identification (“RFID”).

V. SUMMARY

The embodiments described herein relate to applications of radio frequency identification (RFID) technology to monitor and manage inventory, including RFID-enabled dispensers, which permit tracking of small items, such as pills or grains, for which attachment of individual RFID sensors is impractical. Other inventory management applications include level detectors, in which the level of material filling a volume is sensed. Sensor applications include a distributed pressure sensor.

Methods, apparatuses and systems for RFID-enabled information collection are disclosed, including a system comprising an enclosure, a collector coupled to the enclosure, an interrogator, a processor, and one or more RFID field sensors, each having an individual identification, disposed within the enclosure. The interrogator is configured to transmit an incident signal to the collector, causing the collector to generate an electromagnetic field within the enclosure. The electromagnetic field is affected by one or more influences. One or more of the RFID sensors respond to the electromagnetic field by transmitting, via the collector, a reflected signal to the interrogator, the reflected signals containing the individual identifications of the responding RFID sensors. The interrogator is configured to receive the reflected signals, measure one or more returned signal strength indications (“RSSI”) of the reflected signals and send the RSSI measurements and the corresponding identification of the responding RFID sensors as information to the processor. The processor is configured to analyze the information to determine one or more facts about the influences.

Another embodiment disclosed is a RFID-enabled dispenser including a parallel plate waveguide comprising a plurality of conductive layers and a dispensing container placed within the waveguide. The dispensing container has an opening for dispensing items and a dispensing element for moving the items to be dispensed through the opening. The

2

dispensing container also has a traveler for moving items within the dispensing container towards the opening, the traveler moving in response to force exerted by a forcing element. An antenna, coupled to the waveguide, is configured to generate an electromagnetic field within the waveguide in response to an incident signal sent from an interrogator, the electromagnetic field being affected by one or more influences. One or more RFID field sensors are placed inside the waveguide at intervals along the axial direction of the waveguide. Each RFID field sensor has an identification and is capable of responding to the electromagnetic field by transmitting, via the antenna, reflected signals to the interrogator, the reflected signals containing the identification of the responding RFID field sensors. The interrogator is further configured to receive the reflected signals, measure one or more returned signal strength indications (RSSI) of the reflected signals and send the RSSI measurements and the corresponding identification of the responding RFID field sensors as inputs to the processor for use by the processor in making at least one determination about the one or more influences.

Another embodiment disclosed is a RFID-enabled dispenser comprising a holder and a dispensing container placed within the holder. The holder has an elongated structure with multiple antenna cells, each antenna cell containing an RFID circuit having a unique identification. Each antenna cell is of sufficient size for resonance, so that the antenna cell may tune to an operating frequency of its RFID circuit. The dispensing container has an opening for dispensing items from the dispensing container and a traveler for moving items within the dispensing container towards the opening. The traveler moves in response to force exerted by a forcing element. The traveler includes a dielectric body (which may include optional metallic or conductive components), the position of the traveler and its dielectric body activating a particular antenna cell in which the traveler is positioned and enabling the RFID circuit within the particular antenna cell to receive an incident signal from an interrogator and to send a response to the interrogator. The interrogator is configured to receive the response, measure one or more returned signal strength indications (“RSSI”) of the response and send the RSSI measurements and the corresponding identification of the responding RFID field sensors as information to a processor. The processor is configured to use the information received from the interrogator to determine the position of the traveler. The items may comprise packages of one or more objects. In one embodiment, for example, the items may be disk-shaped and include segmented packaging for separating two or more of the objects.

Another embodiment described herein is an apparatus for a radio frequency identification (RFID)-enabled pressure sensing glove, including a glove having a palm side, a back side, and at least one digit. The glove includes a plurality of ring elements, each on a foam pad, the foam pads being attached to the palm side of the glove on the at least one digit and palm, each ring element including a RFID sensor attached to a near field loop, and a microstrip patch antenna on the back side of the glove. The microstrip patch antenna is connected to one or more microstrip lines coupling the antenna to the ring elements, the microstrip lines each terminating in a load element near the end of each digit, which prevents development of a standing wave pattern. Pressure on a ring element activates its RFID sensor allowing the RFID sensor to transmit a signal to an interrogator.

Yet another embodiment described herein is an apparatus for a radio frequency identification (RFID)-enabled pressure sensitive keypad. The RFID-enabled keypad includes a plu-

rality of RFID tags bonded to an operatively insulating and compressible substrate and an operably planar open waveguide, the waveguide being bonded on an operatively insulating dielectric base and in communication with a collector. A load is connected to one end of the waveguide. The substrate bearing the RFID tags is positioned over the base and adjacent to a conductor of the waveguide, one or more of the RFID tags being energized when operably depressed to send signals via the collector to an interrogator, an electromagnetic coupling being enabled between the waveguide and the depressed RFID tag.

Another embodiment described herein is a method of determining one or more influences on a generated electromagnetic field. The method comprises the step of transmitting an incident signal from an interrogator to a collector coupled to a waveguide causing the collector to generate the electromagnetic field along the waveguide. The electromagnetic field may be affected by the one or more influences. The waveguide contains one or more radio frequency identification (RFID) sensors, each RFID sensor having an individual assigned identification. The method further comprises the steps of transmitting a reflected signal from one or more of the RFID sensors via the collector to the interrogator in response to the electromagnetic field, the reflected signal including the individual identification from the responding RFID sensors, measuring one or more returned signal strength indications ("RSSI") of the reflected signal by the interrogator, and sending the RSSI measurements and the corresponding identification of the responding RFID field sensors from the interrogator to a processor. The method further comprises the step of analyzing the RSSI measurements and identifications by the processor to make determinations about the one or more influences.

Another embodiment disclosed is an apparatus for use as a switch, comprising at least one RFID tag, each RFID tag comprising an antenna element and an RFID integrated circuit, at least one source element, and at least one lever arm. Each lever arm is connected to one of the RFID tags, and each lever arm is capable of two positions. One of the positions places the lever arm and the RFID tag connected thereto into alignment with the source element.

Another embodiment disclosed is a system for radio frequency identification (RFID)-enabled information collection comprising one or more antenna cells comprising ring elements, each ring element including a conductive ring connected to a RFID integrated circuit, at least one source element, an interrogator capable of transmitting a signal to the source element and a processor in communication with the interrogator. At least one of the conductive rings is capable of coupling to its source element when the conductive ring is in a first position, energizing the RFID circuit associated with the conductive ring to respond to the interrogator's signal. The processor is capable of deriving information regarding the positions and orientations of the one or more ring elements relative to the one or more sources. The source element may be an antenna element, or in another embodiment the source element may be an open waveguide, such that the ring element can couple to the waveguide structure when it is in the proper position and/or orientation. The conductive ring and the source element may be placed on door components such that the conductive ring couples to the source element only when the door is in a first position.

Other aspects and advantages of the embodiments described herein will become apparent from the following description and appended claims, taken in conjunction with the accompanying drawings, illustrating the principles of the embodiments by way of example only.

VI. BRIEF DESCRIPTION OF THE DRAWINGS

FIG. 1 is a schematic diagram, in accordance with one or more embodiments described herein, of an RFID-enabled enclosure in the form of a cavity comprising a container.

FIG. 2 is a schematic diagram in accordance with one or more embodiments described herein in which an RFID-enabled enclosure is in the form of a cavity comprising a container and a collector comprising an antenna lid on the container.

FIG. 3 is a schematic diagram in accordance with one or more embodiments described herein of an RFID-enabled container with RFID field sensors in the form of an array of RFID integrated circuits.

FIG. 4 depicts a schematic diagram in accordance with one or more embodiments described herein of an RFID-enabled cavity filled with foam and bounded by a conductive fabric exterior.

FIG. 5 depicts a schematic diagram in accordance with one or more embodiments described herein of an RFID-enabled conductive cavity in which a conductive, flexible diaphragm applies pressure to and reduces the volume of the RFID-enabled conductive cavity.

FIG. 6 is a schematic diagram of an RFID-enabled item dispenser having multiple items in each dispensed disc, in accordance with one or more embodiments described herein.

FIG. 7 depicts a schematic diagram in accordance with one or more embodiments described herein of an RFID-enabled container or dispenser having conductive walls and a conductive center post.

FIG. 8a is an illustration of an RFID-enabled container made in accordance with one or more embodiments described herein. FIGS. 8b-8e are illustrations depicting additional details of a capacitively-fed planar inverted F antenna ("PIFA"), such as the one used for the RFID-enabled container of in FIG. 8a.

FIG. 9 is a graph depicting the results of four tests performed using the embodiment of FIG. 8a.

FIG. 10 is a schematic diagram of a spring-operated item dispenser.

FIG. 11 is a schematic diagram of the item dispenser of FIG. 10, modified to be an RFID-enabled item dispenser having an enclosure in the form of a parallel plate waveguide, in accordance with one or more embodiments described herein.

FIG. 12 is a schematic diagram of an RFID-enabled item dispenser having an enclosure in the form of a coaxial waveguide, in accordance with one or more embodiments described herein.

FIG. 13 is a schematic diagram of an RFID-enabled item dispenser in accordance with one or more embodiments described herein, wherein a traveler contains a dielectric body within.

FIG. 14 is a schematic diagram of an embodiment of the holder cells of FIG. 13.

FIG. 15 is a schematic diagram of another embodiment of the holder cells of FIG. 13, illustrated with a traveler, having a conductive pattern, within the holder cell.

FIG. 16 is a schematic diagram of an RFID-enabled item dispenser in accordance with one or more embodiments described herein, having holder cells on two sides of the dispenser, with an electromagnetic short on one side of the holder cells.

FIG. 17 is a schematic diagram of an RFID-enabled item dispenser with the dispensing component outside of the holder in accordance with one or more embodiments herein.

5

FIG. 18 is a schematic diagram of an interrogation of an RFID-enabled item dispenser in accordance with one or more embodiments described herein.

FIG. 19a is a schematic diagram of an RFID-enabled item dispenser, depicting an end view cross section of a dispenser unit, in accordance with one or more embodiments described herein.

FIG. 19b is a schematic diagram of an RFID-enabled item dispenser in which a top conductive layer comprises a top circuit having one or more ring microstrip antenna cells, in accordance with one or more embodiments described herein.

FIG. 19c is a schematic diagram of an RFID-enabled item dispenser having a traveler conductive layer beneath a traveler dielectric layer, in accordance with one or more embodiments described herein.

FIG. 19d is a schematic diagram of an RFID-enabled item dispenser in accordance with one or more embodiments described herein, in which a traveler conductive surface provides a folded ground plane with a short.

FIG. 19e is a schematic diagram of an RFID-enabled item dispenser having a circular cross section and ring microstrip antennas, in accordance with one or more embodiments described herein.

FIG. 19f is a schematic diagram of an RFID-enabled item dispenser having a top conductive layer of one or more microstrip antennas wrapped around a cylinder with a circular cross-section, in accordance with one or more embodiments described herein.

FIG. 20 is a schematic diagram of the palm side of an RFID-enabled pressure sensor glove in accordance with one or more embodiments described herein.

FIG. 21 is a schematic diagram of the back (top) side of an RFID-enabled pressure sensor glove in accordance with one or more embodiments described herein.

FIG. 22 is a schematic diagram of a robot with an RFID-enabled pressure sensor glove in accordance with one or more embodiments described herein.

FIGS. 23a-23c depict alternate embodiments each representative of a finger on the RFID-enabled pressure sensor glove of FIGS. 20-22.

FIG. 24 is a diagram of an RFID tag in accordance with one or more embodiments described herein.

FIG. 25 is a diagram of components of another embodiment described herein.

FIG. 26 is a diagram of the proper placement of the components depicted in FIG. 25.

FIG. 27 illustrates the embodiments of FIGS. 24-26 combined with a screen shot of software displaying the results of a test of a prototype.

FIG. 28 depicts a ring sensor that may be used in various embodiments described herein.

FIG. 29a depicts a ring sensor positioned to couple with a source element in accordance with one or more embodiments described herein.

FIG. 29b depicts a ring sensor, which may be used in one or more embodiments described herein, positioned so as to not couple with the source element.

FIGS. 30a and 30b depict a ring sensor used as a sensor to detect whether a hinged door is in an open or closed position in accordance with one or more embodiments described herein.

FIGS. 31a and 31b depict a ring sensor, which may be used in one or more embodiments described herein, configured to be used as a switch.

While the appended claims are subject to various modifications and alternative forms, specific embodiments thereof are shown by way of example in the drawings and the accom-

6

panying detailed description. It should be understood, however, that the drawings and detailed description are not intended to limit the appended claims to the particular embodiments described herein. This description and disclosure is instead intended to cover all modifications, equivalents, and alternatives falling within the scope of the present invention as defined by the appended claims.

VII. DETAILED DESCRIPTION

The drawings are not necessarily to scale and certain features may be shown exaggerated in scale or in somewhat generalized or schematic form in the interest of clarity and conciseness. In the description which follows, like parts may be marked throughout the specification and drawings with the same reference numerals. The foregoing detailed description is provided for a more complete understanding of the accompanying drawings. It should be understood, however, that the embodiments described herein are not limited to the precise arrangements and configurations shown. Although the design and use of one or more embodiments are discussed in detail below, it should be appreciated that the present description provides many inventive concepts that may be embodied in a wide variety of contexts. The specific aspects and embodiments discussed herein are merely illustrative of ways to make and use the embodiments described, and do not limit the scope of the appended claims. It would be impossible or impractical to include all of the possible embodiments and contexts of the appended claims in this description. Upon reading this description, alternative embodiments within the scope of the appended claims will be apparent to persons of ordinary skill in the art.

FIG. 1 depicts one or more embodiments described herein comprising two or more RFID field sensors 100, a collector 110, a coupling 120, and an enclosure 130 comprising an enclosing surface or volume 125 defining a resonator (such as a waveguide or a cavity, as depicted in FIG. 1) or other enclosure 130. The collector 110 funnels, via the coupling 120, electromagnetic energy creating an electromagnetic field 135 into the enclosure 130. The electromagnetic field 135 is distributed throughout the enclosure 130 according to Maxwell's equations. The distribution of the electromagnetic field 135 within the enclosure 130 may be affected by one or more conditions referred to herein as influences 140. The influences 140 may be connected to substances such as materials or liquids within the enclosure. The RFID field sensors 100 are within and preferably distributed throughout the enclosure 130. An RFID reference sensor 115 is typically located within or adjacent to the collector 110.

Continuing to refer to FIG. 1, an interrogator 145 sends an incident signal 150, to the collector 110, which, as described above, generates the electromagnetic field 135 within the enclosure 130. The RFID field sensors 100 and/or the RFID reference sensor 115, each having their own identification information, respond to the electromagnetic field 135 by sending reflected signals 155 with the identification of the responding RFID field sensor 100 or RFID reference sensor 115, to the interrogator 145 via the coupling 120 and collector 110. The incident signal 150 and reflected signals 155 comprise radio frequency (RF) signals. The interrogator 145 measures returned signal strength indications ("RSSI") of the reflected signals 155, the RSSI measurements preferably including the strength and the phase of the reflected signals 155. A processor (not separately depicted in FIG. 1) residing in, or connected to, the interrogator 145 determines the characteristics of the influences 140 based on the reflected signals 155 from the one or more RFID field sensors 100 and/or the

RFID reference sensor **115**. Measurements of the reflected signal **155** from the RFID reference sensor **115** may be compared to measurements of the reflected signals **155** from the responding RFID field sensors **100** to identify and remove extraneous variations not related to the influences on the electromagnetic field.

In alternate embodiments, measurements of the electromagnetic field **135** may be made by the RFID field sensors **100** and reference sensor **115** and transmitted to the interrogator.

Although the cross-section of the enclosing surface **125** in FIG. **1** is depicted as a rectangle or box, the enclosing surface **125** may be of any shape convenient to the application. Although RF signals described above are commonly transmitted at 900 MHz UHF, different frequency bands may be used with the embodiments described herein. The RFID sensors **100**, **115** used may be for example RFID integrated circuit sensors, Surface Acoustic Wave (SAW) RFID sensors or any other RFID sensor suitable for the purpose.

FIG. **2** depicts one or more embodiments of the present disclosure described herein in which the collector comprises a lid antenna **200** on a cylindrical enclosure **210**, which defines a cavity **215** (or waveguide) and which is at least partially filled with fill material **220** to a fill level **222**. The amount of fill material **220** and corresponding fill level **222** may vary over time. An interrogator **230** sends an incident signal (not depicted) to a coupler (not depicted in FIG. **2**) which transfers the incident signal into the cavity **215** so as to establish an electromagnetic field distribution therein. The coupler might comprise, for example, an aperture shared between the lid antenna **200** and the cavity **215**, or the coupler might comprise a probe from the lid antenna **200** that protrudes into the cavity **215**.

Continuing to refer to FIG. **2**, one or more RFID field sensors **225** having identification information are positioned within the enclosure **210**. Each RFID field sensor **225** may be, for example, an RFID integrated circuit, a SAW RFID or any other suitable RFID sensor. The RFID field sensors **225** that respond to the electromagnetic field send their identification information in reflected signals to the interrogator **230** via the lid antenna **200**. The fill material **220** and fill level **222** comprise influences affecting the electromagnetic field. The interrogator **230** receives the reflected signals, measures the RSSI of the reflected signals, and sends the RSSI measurements with the corresponding identification of the responding RFID field sensors **225** to a processor **235**, which may be within or connected to or otherwise in communication with the interrogator **230**. The processor **235** determines the type of fill material and/or the fill level based on the information received from the interrogator **230**. In FIG. **2**, the processor **235** is depicted within the interrogator **230**, but the processor **235** and interrogator **230** could be separate and in communication with each other. One or more reference RFID field sensors (not depicted in FIG. **2**) may be disposed on the exterior of the enclosure **210** or on or within the lid antenna **200**.

In an alternative embodiment, the RFID field sensors **225** measure or estimate the received power and/or phase of the electromagnetic field and transmit the measurements to the interrogator **230**, along with the corresponding identification numbers of the responding RFID field sensors **225**.

For embodiments of the present disclosure in which the enclosure **210** forms a hollow waveguide or cavity, propagation of the electromagnetic field down the cavity or waveguide depends on wavelength, so the cavity or waveguide may need to be of a sufficient size such that the signal is above a "cutoff" frequency. In one or more embodiments, the cavity or waveguide is below cutoff when empty

but is above cutoff during the presence of an influence. For example, the dielectric property of a fill material can shift the waveguide cutoff frequency below the RFID operating frequency to enable one or more RFID field sensors. In other embodiments, metamaterials are employed in the cavity or waveguide to lower the cutoff frequency as an alternative to increasing the waveguide or cavity size. In other embodiments, a second conductor, such as an inner conductor, which may be in a coaxial configuration or offset, is used so as to avoid size restrictions and the associated cutoff frequency. In embodiments of the present disclosure having an outer conductor and an inner conductor, the electromagnetic field will be generated between the outer conductor and the inner conductor. In such a configuration, the waveguide is capable of propagating a wave that is substantially transverse electromagnetic (TEM). Transverse waves are waves where the disturbance is perpendicular to the direction of propagation. If one throws a stone into a lake, a transverse wave is created: the waves move outward from the point the stone entered the water, but to create the "wave," the water in the lake moves up and down. In TEM waves, the electric and magnetic field disturbances are perpendicular both to each other and to the direction of the propagation of the wave. The outer conductor and the inner conductor may have various shapes and/or cross sections. The inner conductor may be centered within the outer conductor or may be offset.

FIG. **3** depicts an exploded diagram of one or more embodiments of an RFID-enabled information collection system comprising a thin transmission line **300** attached to a non-conductive enclosure **315**, with one or more RFID tags such as RFID integrated circuit chips **310** attached in parallel fashion along the transmission line **300**. An antenna **320** attached to the enclosure **315** serves as the collector. The antenna **320** is connected to the transmission line **300**. An interrogator **340** sends an incident signal to the antenna **320**, which launches an electromagnetic field along the transmission line **300**. Similar to conventional RFID tags, the thin RFID transmission line **300** can be printed on a thin, flexible plastic layer that attaches to the inside or outside of the enclosure **315** with an adhesive.

In the embodiment depicted in FIG. **3**, the enclosure **315** is nonconductive and sufficiently thin-walled, such that the electromagnetic field along the transmission line **300** is influenced by fill material **330** and its fill level **325** inside the enclosure **315**. Each RFID integrated circuit chip **310** responding to the electromagnetic field sends its identification with a reflected signal to the interrogator **340**, which measures the RSSI, such as the strength and or phase of the reflected signals. In alternative embodiments, the RFID integrated circuit chips **310** on the transmission line **300** may measure the power of the electromagnetic field and transmit the measurements of electromagnetic field, along with the identification of each RFID integrated circuit chip **310** performing the measurement, to the interrogator **340**.

The interrogator **340** includes or is connected to a processor **345**, which uses the RSSI measurements with algorithms running on the processor **345** to determine the fill level **325**, distribution, permittivity, or conductivity of one or more fill materials **330** in the enclosure **315**. The algorithms can be determined by empirical methods, by modeling, or by solving the inverse problem, a process known to those skilled in the art in which the field solutions are determined based on an estimate of the fill level **325** and/or material, the results are compared to the measured results, and a nonlinear global optimizer is used to refine the best estimate of the fill level and/or material in order to minimize the difference between the measured response and the simulated response.

In one or more embodiments, the fill material **330** may be a liquid that effectively shorts the transmission line **300**, thus prohibiting response from one or more of the RFID integrated circuit chips **310** that are positioned below the fill level **325**.

If the fill material **330** comprises one of two or more similar substances with similar electrical properties, such as cornflakes and oatmeal, the processor **345** may be able to tell the fill level but not distinguish between the similar substances. If the substances are different, such as liquid versus oatmeal or gravel versus oatmeal, the processor **345** may be able to distinguish the type of material **330** as well as the fill level **325** and/or volume.

FIG. 4 depicts a schematic diagram of another embodiment described herein in which a cavity **405**, at least partially filled with foam **400**, is formed within a conductive fabric boundary **410**. A fabric antenna **420** on the outside of the conductive fabric boundary **410** functions as a collector. An interrogator **430** sends an incident signal (not depicted in FIG. 4) to an antenna **420**, generating an electromagnetic field in the cavity **405** with a coupling in the form of a cavity feed probe or aperture (not depicted in FIG. 4). The interrogator **430** receives reflected signals (not depicted in FIG. 4) containing identification information from one or more RFID integrated circuits **435** positioned within the cavity **405** and responding to the electromagnetic field. One or more depressions **445** in the cavity **405** acts as an influence on the electromagnetic field. The interrogator **430** measures the RSSI of the reflected signals and sends the RSSI measurements and the corresponding identification of the RFID integrated circuits **435** to a processor **440**, within or in communication with the interrogator **430**. The processor **440** may analyze information received from the interrogator **430** to deduce the location, or locations, at which the cavity **405** has the depressions **445**.

In an alternate embodiment of the system of FIG. 4, the RFID integrated circuits **435**, as they respond to the electromagnetic field in the cavity **405**, measure the electromagnetic field strength and/or phase and send the measurements with their corresponding identification in response to the interrogator **430**.

In yet another alternate embodiment of the present disclosure depicted in FIG. 4, a conductive layer **402** is formed by a conductive paint on the boundary **410**, which comprises an inflatable structure. The conductive layer **402** of paint is continuous and contiguous for many applications, but some embodiments might allow for use of patterns of conductive paint. Fill material within the cavity **405** created by the inflatable structure comprises one or more gases. The temperature and pressure of the gas or gases exert an influence on the flexible conductive boundary **410** of the cavity **405** and thus affect an electromagnetic field distribution (not specifically depicted in FIG. 4 but represented in general previously as electromagnetic field **135** in FIG. 1) within the cavity **405**, the electromagnetic field being generated by the antenna **420** in response to a signal from the interrogator. RFID integrated circuits **435** within the cavity **405** respond to the electromagnetic field and transmit the identification of the responding RFID integrated circuit(s) **435** in reflected signals to the interrogator **430**, which measures RSSI of the reflected signals and sends the measurements to the processor **440**. Alternatively, the strength and phase of the electromagnetic field is measured by the RFID integrated circuits **435**, which transmit the measurements and the specific identification of each of the responding RFID integrated circuits **435** to the interrogator **430**. The processor **440** in communication with the interrogator **430** can use the information received from the interrogator **430** to determine the volume of the gas or gases within the cavity **405**, thus permitting solution for the pressure,

assuming the temperature is known. If there is a depression **445** of the boundary **410**, the depression **445** would act as an influence on the electromagnetic field and facts about the extent of the depression **445** could be determined by the processor **440** in analyzing the information received from the interrogator **430**.

FIG. 5 depicts one or more embodiments of the present disclosure in which a conductive, flexible diaphragm **510** applies pressure to and reduces the volume of a conductive cavity **520**, resulting in changes in an electromagnetic field (not depicted) within the cavity **520**. An antenna (not depicted in FIG. 5) which receives an incident signal from an interrogator **535** and couples electromagnetic energy to the cavity **520**, creating the electromagnetic field within the cavity **520**. The electromagnetic field distribution within the cavity **520** is sensed by one or more RFID field sensors **530** within the cavity **520**. The RFID field sensors **530** may respond with reflected signals, including identification of the responding RFID field sensors **530** to the interrogator **535**. The interrogator **535** measures the RSSI of the reflected signals and sends the measurements and the corresponding identification of the responding RFID field sensors **530** as information to a processor **540**, within or connected to the interrogator **535**. The processor **540** uses the information to determine the pressure applied by the diaphragm **510**. The processor **540** in FIG. 5 is depicted as being within the interrogator **535**, but the processor **540** could also be in communication with the interrogator without being within the interrogator **535**.

In an alternate variation of the embodiment of FIG. 5, the cavity width is designed to render the cavity **520** close to the cutoff frequency on that dimension. The degree to which the diaphragm **510** is depressed determines how far below cutoff the antenna is as a function of frequency. The interrogator **535** may communicate over a number of channels, each channel distinguished by a range of frequencies. The interrogator **535** may hop between alternative channels using a frequency-hopping spread spectrum technique, as is well known in the art. An RSSI associated with each RFID field sensor **530** is reported for the various frequencies used by the interrogator **535**, thus providing information from which the extent and location of the volume reduction of the cavity **520** can be estimated.

FIG. 6 will be discussed in more detail with FIG. 10 below.

Referring now to FIG. 7, an enclosure in the form of a container or dispenser **710**, with a quantity of N embedded RFID tags **720**, enables sensing of fill material **725** and fill level **730**. The container or dispenser **710** has an inner conductor **715** and conductive container walls **705**. (The inner conductor in FIG. 7 is depicted as coaxial, but in other embodiments, the inner conductor may be offset. The enclosure and inner conductor may have a variety of cross sectional shapes, such as circular, triangular, rectangular, trapezoidal, or any other polygonal-shape.) A lid antenna **735** serves as a coupling and, stimulated by an incident signal from an interrogator **745**, excites a coaxial waveguide formed by the container **710** and inner conductor **715** and generates an electromagnetic wave (not specifically depicted in FIG. 7). The electromagnetic wave travels down the waveguide and provides power to the quantity N RFID tags **720**. The powered RFID tags **720** respond by transmitting their identification to the interrogator **745**, which measures the RSSI and provides information comprising the RSSI measurements and the corresponding identification of the responding RFID tags to a processor **740**, within or connected to the interrogator **745**. The processor **740** may be configured to use the information received from the interrogator **745** to determine facts regarding the fill material **725** and fill level **730**. Preferably, a refer-

ence RFID tag (not depicted in FIG. 7) resides on top of or within the lid antenna 735, or is placed somewhere on the exterior of the container 710. The reference signal strength is compared with that from the other responding RFID tags 720 within the waveguide in order to remove variations due to the exterior propagation channel between the interrogator 745 and the lid antenna 735. Although the bottom of the container or dispenser 710 (opposite the lid) presents a short circuit of the coaxial structure in the embodiment depicted in FIG. 7, in general, a matched or other suitable load can be used to terminate the waveguide. Material can be removed through the lid antenna 735 or, alternatively, from a dispensing mechanism (not shown). Alternatively, the lid and antenna can be on opposing ends of the container or dispenser 710.

FIG. 8a is a diagram of an exterior of a prototype of another embodiment described herein. In FIG. 8a, a reference RFID tag 800 is fastened to the top of a container lid antenna 810, which may comprise a capacitively-fed planar inverted F antenna (“PIFA”). A container wall 820 also serves as the outer conductor of a coaxial waveguide in FIG. 8a. An inner conductor (not shown in FIG. 8a) protrudes through the lid 810, with isolation to prevent shorting to the lid 810, and makes contact with a capacitive feed plate (not visible in FIG. 8a). The container is filled with oatmeal, an example of a fill material. An interrogator (not visible in FIG. 8a) sends an incident signal to the container lid antenna 810, which generates an electromagnetic field. One or more field RFID tags (not depicted in FIG. 8a), each having identification information, are placed on the internal side (not visible in FIG. 8a) of the container outer conductive wall. The field RFID tags and the reference RFID tag 800 respond to the electromagnetic field, transmitting their identifications via the container lid antenna 810 to the interrogator. The interrogator measures the RSSI of the transmissions from the responding RFID tags and sends information including the measurements and the identification of the corresponding responding RFID tags for recordation and analysis by a processor (not visible in FIG. 8a) within or in communication with the interrogator. The processor uses the recorded information to determine the quantity of oatmeal within the container 820. Measurements of responses from the RFID reference tag 800 may be compared to measurements of responses from the responding field RFID tags to identify and remove extraneous variations not related to the influences on the electromagnetic field.

FIGS. 8b, 8c, 8d and 8e are diagrams showing additional details of a capacitively-fed planar inverted F antenna (“PIFA”), such as the antenna 810, which could be used with embodiments described herein similar to the one pictured in FIG. 8a. As depicted in FIG. 8b, which provides a side view of the lid antenna, the lid antenna 810b comprises a top plate 812, a capacitive feed plate 813, and a ground plate 814, with a shorting strip 818 connecting the top plate 812 to the ground plate 814. A feed post 815 attached to the capacitive feed plate 813 passes through an opening in the ground plate 814 and extends into the cavity of container 820e. The feed post 815 is provided with an insulating standoff 816 from the body of the antenna 810b at a clearance 817. FIG. 8c provides a top view of the lid antenna 810b, the top plate 812 and the shorting strip 818.

FIG. 8d and FIG. 8e depict a patch lid antenna 810d for a coaxial feed to an embodiment of the present disclosure comprising an RFID-enabled container 820e with conductive walls 822e. FIG. 8d depicts a patch lid antenna 810d with top and bottom layers 811d and a feed post 815d (which may also be called a “center post”). Optional threads 823 may be used to couple the lid antenna 810d to the container 820e. As depicted in FIG. 8e, within the container 820e, the feed post

815d may be received by an insulating center post guide 824e terminating in a conductive termination pad 825e.

FIG. 9 depicts a graph of results of four different trials using the prototype of FIG. 8a. As discussed above, for each trial, when the interrogator sends an incident signal to the container lid antenna 810, the container lid antenna 810 receives an electromagnetic field. The interrogator measures RSSI from signals sent by RFID tag 1 and the reference tag and sends the measurements and identification of the corresponding RFID tags 800 to the processor. For each trial, the container 820 is removed from its position near the interrogator, emptied, and then filled with oatmeal to the level indicated on the X-axis and a new trial is run. For this prototype, no attempt was made to maximize the power passed from the container lid antenna 810 to the container 820, nor was any attempt made to equalize the sensitivity for different depths of fill material. Note how the trial lines vary somewhat at lower levels of cups of oatmeal, but the trial plots converge more closely as the cups of oatmeal increase. This convergence indicates that in these tests, this particular prototype is more accurate for higher fill levels than for lower level fills. However, the prototype serves the purpose of monitoring the fill level of a container 820 or dispenser. No batteries are required, and a single interrogator may remotely monitor a wide angular span of different containers or dispensers.

The embodiments described herein permit moderate to very fine resolution RFID tracking. A pill dispenser is an example of an application that would require fine resolution RFID tracking. Pills are typically too small for secure attachment of conventional RFID tags. In addition, accidental ingestion of RFID tags might not be beneficial for the patient. Furthermore, the tag cost would likely be prohibitive for attachment at the pill level.

Referring now to FIG. 10, a schematic of a conventional dispenser, such as a pill dispenser, is shown. The items 1000 to be dispensed, which may be pills or other small items, from a dispenser 1005 are placed on top of or adjacent to a traveler 1010, which compresses a spring 1020. Items 1000 can be removed by a plunger 1025 which pushes one of the items 1000 through an opening 1030. Spring tension in the compressed spring 1020 pushes the traveler 1010 and items 1000 forward to fill the vacated slot.

FIG. 6 is a schematic diagram depicting an RFID-enabled dispenser 600 that would be placed in a holder (not depicted in FIG. 6) having one or more cells (not depicted in FIG. 6). The RFID-enabled dispenser of FIG. 6 could be used as part of embodiments of the present disclosure like those depicted in FIGS. 11-19 herein, which are discussed in more detail below. The dispenser 600 may have a cylindrical structure 609, with a circular cross-section 605. A traveler 620 positioned by a spring 642 moves items 602, which can be pushed by a plunger 644 (acting through a first opening 638) through second opening 640. The items 602 might comprise disks containing one or more individual objects 613. The disc 602 depicted in the inset of FIG. 6 is segmented in a pie fashion, with an object 613 in each segment, but the item 602 may comprise any kind of convenient or desired type of packaging and may have shapes other than that of a disc. Items comprising a package containing a plurality of objects may be used with various embodiments of the RFID-enabled item dispenser of the present disclosure.

FIG. 11 is an exploded view of a modified version of the dispenser of FIG. 10, wherein additional components are included to create an embodiment of the present disclosure, an RFID-enabled dispenser. As in FIG. 10, the items 1000 to be dispensed are placed on top of or adjacent to a traveler 1130, which compresses a spring 1120. But the RFID-en-

13

abled dispenser **1102** of FIG. **11** has additional components which include a collector **1100**, such as an antenna, conductive layers **1105** to form a waveguide, such as a parallel plate waveguide **1110** (the parallel plates of the parallel plate waveguide comprising the conductive layers **1105**), and one or more RFID sensors **1115**. The RFID sensors **1115** are positioned on one or both sides of the parallel plate waveguide **1110** such that the ends establish electrical connection to the waveguide conductive layers **1105**. The conductive layers **1105** are typically solid but specialized applications may permit the use of patterned conductive layers. The RFID sensors **1115** could be placed intermittently or periodically along the axial direction of the waveguide **1110**. An interrogator, not depicted in FIG. **11**, sends an incident signal to the collector **1100**, creating an electromagnetic field in the waveguide **1110**. The RFID sensors **1115** may respond to the electromagnetic field and send information including their identification as reflected signals to the interrogator. The interrogator measures the RSSI of the reflected signals and transmits information comprising the measurements and corresponding RFID sensor identification to a processor within or in communication with the interrogator. The processor records and/or analyzes the information received from the interrogator and may determine data concerning the items **1000** to be dispensed, such as the number of items already dispensed and/or the number of items remaining in the dispenser **1102** and possibly the type or material of the items **1000**. A first opening **1122** in one waveguide plate permits a plunger **1125** to move forward, and a second opening **1124** in the opposing waveguide plate permits items **1000** to be dispensed. Both the first opening **1122** and the second opening **1124** are sufficiently small to not disrupt continuity of the conductive waveguide **1110**. Alternatively, the first and second openings **1122**, **1124** may be located on the two sides orthogonal to the conductive waveguide plates, in which case an RFID sensor **1115** would be positioned so as not to interfere with the plunger **1125** or block the dispenser opening. As an alternative to a plunger **1125**, other dispensing mechanisms could be used to dispense items from the dispenser **1102**.

In a variation of the embodiment of FIG. **11**, the traveler **1130** may be modified from a conventional form to have one or more conductive surfaces, or to be predominantly conductive, so as to present an electromagnetic short to the waveguide **1110**. The position of the modified traveler **1130**, and hence the short, affects the wave pattern of the electromagnetic field and hence the RSSI, and possibly phase measurements, from each of the one or more RFID sensors **1115**. For example, the one or more conductive surfaces could short one of the adjacent RFID sensors **1115**. Alternatively, the one or more conductive surfaces could enable one of the RFID sensors **1115** by establishing the proper impedance presented by the RFID sensor **1115** to the waveguide. The processor, upon receiving the information from the interrogator, determines the quantity of the items **1000** remaining in the RFID-enabled dispenser **1102**, and possibly the type or material of the items **1000**.

In another version of the embodiment of FIG. **11**, an RFID sensor **1115** is embedded into the traveler **1130** such that the traveler **1130** absorbs incident energy from the incident signal, providing a different type of load to the waveguide **1110** and an RSSI value (and possibly phase) corresponding to the terminal end of the waveguide **1110**. The position of the traveler **1130** would be determined from RSSI measurements made by the interrogator from signals carrying identification information sent by the responding RFID sensors **1115** to the interrogator. (Alternatively, in some embodiments, the RFID

14

sensors **1115** may measure an electromagnetic field created by the configuration of the embodiment and transmit the RSSI measurements to the interrogator.) In another embodiment, the traveler **1130** is designed to present a predetermined, but arbitrary, electromagnetic load.

FIG. **12** depicts one or more embodiments of the present disclosure in the form of a dispenser **1202** in which the collector **1200** provides an input signal to a spring end of the waveguide **1210** (on the opposite side compared to FIG. **11**). The waveguide of FIG. **12** is a type of coaxial waveguide **1210** with the spring **1220** serving as a center conductor and exerting a force to traveler **1230**.

In a variation of the embodiment of FIG. **12**, the surrounding structure constitutes a parallel plate waveguide, while in another version the structure constitutes a fully enclosed conductive cylinder **1205**, of arbitrary shaped cross-section. For the parallel plate embodiment, one or more RFID sensors (not depicted in FIG. **12**) having individual identification information would be positioned along one or both gaps between the parallel plates. For the fully enclosed cylinder embodiment, the RFID sensors would be positioned in the internal volume or at the entry/exit plane of the waveguide.

In each version of the embodiment of FIG. **12**, an interrogator (not depicted) sends an incident signal to the collector **1200**, which generates an electromagnetic field. The RFID sensors which respond to the electromagnetic field send their identification information via the collector **1200** to the interrogator, which measures the RSSI and sends the measurements and corresponding identification information to a processor, within or in communication with the interrogator, for analysis. (Alternatively, the RFID sensors make measurements of the electromagnetic field and send the measurements and the responding RFID sensors' identification as reflected signals via the collector **1200** to the interrogator.) The processor uses the measurements and sensor identification information to determine the amount or type of items within the dispenser and/or the number of items which have been dispensed.

FIG. **13** depicts a cross-section of a fine resolution RFID dispenser assembly **1300** in accordance with another embodiment described herein. In FIG. **13**, a dispenser **1302**, with items **1325** to be dispensed within, is placed within a holder **1305**, which comprises an elongated structure with multiple holder cells **1310**, each holder cell **1310** containing an RFID circuit **1315** with an individual identification. The holder cells may comprise but are not limited to parallel plate cells. A plunger **1335**, acting through a first opening **1338**, pushes an item **1325** to be dispensed through a second opening **1340**. A traveler **1320** contains a dielectric body **1330** within and is connected to a spring **1345**, operating similarly as in FIGS. **11** and **12**. The position of the traveler **1320** is determined by the number of items **1325** remaining within the dispenser **1300**. The position of the traveler **1320** and its dielectric body **1330** enables one of the RFID holder cells **1316** to be energized in that it receives signals from an interrogator (not depicted) and responds to the signals. The interrogator and a processor within or in communication with the interrogator, upon receiving the unique ID code of the responding RFID circuit in the energized RFID holder cell **1316**, are able to deduce the number of items **1325** remaining within the dispenser. (In alternate embodiments, all holder cells except one could be energized by an appropriate design, and the number of items remaining in the dispenser could be deduced by the interrogator and an appropriately programmed processor by determining the identity and thus the location of the non-responding holder cell).

15

Details of the holder cells of FIG. 13 are provided in FIG. 14. Each holder cell 1310 comprises a top floor 1410 and bottom floor (not visible in FIG. 14), each with a corresponding conductive pattern 1425, 1430. The top and bottom floor conductive patterns 1425, 1430 may be identical. The interior sections 1440 of the floors are hollow in order to support the dispenser 1302 body (not depicted in FIG. 14).

FIG. 15 is a schematic diagram depicting a holder cell 1310 and a resulting conductive pattern 1500 from the traveler 1320 when the traveler 1320 moves within the structure of a holder cell 1310, in accordance with one or more embodiments described herein. Referring back to FIG. 13, note that the convergence of the dielectric body 1330 of the traveler 1320 with the conductive patterns 1425, 1430 of the holder cell 1310 energizes an RFID circuit (not depicted in FIG. 15) within the holder cell 1310.

FIG. 16 depicts one or more embodiments of an RFID enabled dispenser 1600 in accordance with the present disclosure. Similar to the embodiment depicted in FIG. 13, the dispenser 1600 comprises a dispensing chamber 1612, with items 1625 to be dispensed within, placed within a holder 1605. The holder 1605 comprises an elongated structure with multiple holder cells 1610, each holder cell 1610 containing an RFID sensor 1615 with a unique identification. A plunger 1635 is designed to act through a first opening 1638 to push an item 1625 to be dispensed through a second opening 1640. A traveler 1620 contains a dielectric body 1630 within and compresses a spring 1645, operating similarly as in FIGS. 11-13. The position of the traveler 1620 is determined by the number of items 1625 remaining within the dispenser 1600. Unlike FIG. 13, in FIG. 16, an electromagnetic short 1650 on one end of the holder cells 1610 functions to reduce the physical size of the holder cell 1610 required for resonance, such as a quarter-wave patch antenna or a planar inverted-F antenna (PIFA). The position of the traveler 1620 and its dielectric body 1630 enables one of the holder cells 1610, a RFID holder cell 1616 that is energized, to function as an operable antenna at the frequency of operation, and hence enables the RFID sensor in the energized holder cell 1616 to receive signals from an interrogator (not depicted) and to respond to the signals. The interrogator and a processor within it, upon receiving the unique ID code of the responding RFID sensors 1615, are able to deduce the number of items 1625 remaining within the dispenser 1600.

FIG. 17 depicts one or more embodiments of an RFID enabled dispenser 1700 in accordance with the present disclosure. In structure and operation, the embodiment in FIG. 17 is similar to that of FIGS. 13 and 16. The dispenser assembly 1700 includes a dispensing chamber 1712, with items 1725 to be dispensed, placed within a holder 1705. The holder 1705 comprises an elongated structure with multiple holder cells 1710, each holder cell containing an RFID sensor 1715 with a unique identification. A plunger 1735 is designed to act through a first opening 1738 to push an item 1725 to be dispensed through a second opening 1740. A traveler 1720 contains a dielectric body 1730 within and compresses a spring 1745, operating similarly as in FIGS. 11-13 and 16. The position of the traveler 1720 is determined by the number of items 1725 remaining within the dispenser 1700. As with the embodiment of FIG. 16, an electromagnetic short 1750 on one end of the holder cells 1710 functions to reduce the physical size of the holder cell 1710 required for resonance, such as a quarter-wave patch antenna or a planar inverted-F antenna (PIFA). The position of the traveler 1720 and its dielectric body 1730 enables one of the holder cells 1710 to function as an operable antenna at the frequency of operation, and hence enables the RFID sensor in the energized cell to

16

receive signals from an interrogator (not depicted) and to respond to the signals. In the embodiment of FIG. 17, the dispensing chamber 1712 of the RFID enabled dispenser 1700 is separable from the holder 1705, as depicted.

FIG. 18 illustrates another embodiment in which a remote RFID reader (also called an interrogator) 1800 interrogates an RFID-enabled dispenser 1805, and only a single active RFID holder cell 1810, determined by a traveler 1815 position, responds. A holder 1820 comprises a collection of holder cells 1825, each of which may comprise any of a number of types of antennas, including but not limited to half-wave microstrip patches, quarter-wave patches, and PIFAs. Each holder cell 1825 contains an RFID sensor 1830. When the traveler 1815, positioned by a spring 1816, moves to the location of the representative holder cell 1810, that holder cell 1810 is energized, that is, suitably tuned or enabled as an antenna to receive energy from the interrogator 1800, transfer energy to the particular RFID sensor 1812 operatively connected to the energized holder cell 1810, and re-radiate energy from the RFID sensor 1812 to the interrogator 1800. When the traveler 1815 is not positioned within the location of the holder cell 1810, holder cell 1810 is not conducive to transferring energy from the collector means to the RFID sensor 1812 associated with this particular holder cell. When the traveler 1815 is within the location of the holder cell 1810, this particular holder cell 1810 activates and sends signals back to the interrogator 1800 for analysis by a processor (not separately depicted in FIG. 18) within or in communication with the interrogator 1800. Based on the RFID sensor 1812 that responds, the processor can determine the position of the traveler 1815 and hence the quantity of items 1835 remaining within the dispenser 1805 (or the quantity of items which have been dispensed). As with the embodiments of FIGS. 13 and 16, a plunger 1845 acts through a first opening 1838 to push an item to be dispensed through a second opening 1840.

To augment the effect of the traveler 1815 residing within the holder cell 1810; i.e. to enhance the ability of the energized holder cell 1810 to couple energy to the RFID sensor 1812 that shares the same holder cell 1810 as the traveler 1815, the structural body of traveler 1815 might include an enhanced coupler. Examples of possible enhanced couplers include but are not limited to a high dielectric body that tunes (1) the resonant frequency of the holder cell 1810 so as to be functioning as an antenna; (2) the impedance of the holder cell 1810 to match that of a collector; or (3) the resonance of the energized holder cell 1810 to affect the cavity impedance response of the holder cell 1810. In another embodiment, the traveler 1815 might comprise a top conductive pattern and a bottom conductive pattern with an insulator in the middle. In yet another embodiment, the traveler 1815 might comprise a short between the top and bottom conductive patterns, in which the short tunes the holder cell 1810 as the traveler 1815 enters.

Communication protocols organize exchanges of information between devices. The response of the RFID sensors within the holder cells functioning as an antenna of FIG. 18 may follow such a communication protocol, with the interrogator also following the same protocol. One such protocol is the EPCglobal Class 1 Generation 2 protocol.

FIG. 19a is a combined front and side view of another embodiment described herein in which an RFID-enabled item dispenser 1900 dispenses items 1902. A first half 1906 of conductive cell patterns are formed on a first printed circuit board (a first PCB) 1905 and a second half 1908 of the conductive cell patterns are formed on an opposing (or "back") side (a second PCB) 1910 with a dispenser unit 1915 between the first and second PCBs 1905, 1910. Similar to

previous embodiments described above, a traveler **1920** enables communications to and from an RFID circuit (not depicted in FIG. **19a**) within a particular cell **1931** of the holder cells **1930** formed by the first and second halves of the conductive patterns **1906**, **1908**. A top conductive pattern **1935** on the traveler **1920**, possibly in conjunction with a dielectric body, enables the particular cell **1931** hosting the traveler **1920** to receive and send RFID signals from/to the interrogator. (As the traveler changes position, other holder cells would become activated.)

Continuing to refer to FIG. **19a**, the conductive patterns **1906**, **1908** on the first and second PCB's **1905**, **1910** might be different; e.g., the first half of the conductive pattern **1906**, on the first PCB, might be characterized with one or more empty regions, whereas the second half **1908** of the conductive pattern, on the second PCB **1910**, might be a single filled conductive region. In other embodiments, the conductive patterns **1906**, **1908** might be identical.

FIG. **19a** also depicts a dispenser door **1940** at the base of the dispenser **1900**. Although other embodiments discussed herein have indicated a spring that presents a force to propel the traveler **1920**, other mechanisms (called "forcing elements" herein) might be used to propel the traveler **1920**, such as (but not limited to) gravity (as depicted in FIG. **19a**), levers, masses placed above the traveler **1920** in the presence of gravity, or gears.

In a variation of the embodiment depicted in FIG. **19a**, the second PCB **1910** does not contain the second half of the conductive pattern **1908**. Instead, an additional conductive pattern is placed on the back side of the traveler **1920**. In various embodiments, the traveler may have a conductive pattern on one side and solid metal on the other or the traveler may have solid metal on one side and a dielectric on the other or both sides of the traveler may have conductive patterns. In one or more embodiments of the present disclosure, the traveler may have a side with a solid metal and one of the PCB's may have a continuous ground plane. When the traveler rests in a holder cell functioning as an antenna, the traveler shorts out the holder cell, deactivating it and its operation as an antenna. As other holder cells are activated, the location of the de-activated holder cell provides the location of the traveler and thus discloses the number of items contained in the dispenser.

FIG. **19b** is a schematic diagram depicting one or more embodiments of the present disclosure in the form of an RFID-enabled item dispenser **1900b** in which a top conductive layer **1906b** comprises one or more ring microstrip antenna circuits **1901b**, each of which is attached to an RFID sensor **1915b**. As the terms are used with respect to FIGS. **19a-19f**, a "conductive layer" is not necessarily a solid conductive layer. The top conductive layer **1906b** is conductive in the sense that it includes the ring microstrip antenna circuits or other antenna pattern; it does not have to be a solid conductive layer. The ring microstrip antenna circuits **1901b** may be rectangular, as depicted in FIG. **19b**, circular, triangular or have some other configuration. The top conductive layer **1906b** is attached to a dielectric layer **1907b**. A traveler conductive layer **1935b** is parallel and adjacent to the dielectric layer **1907b**. When adjacent to one of the ring antenna circuits **1916b**, the traveler conductive layer **1935b** enables the adjacent ring microstrip antenna circuit **1916b**, with its RFID sensor, to send and receive signals to and from an interrogator (not depicted in FIG. **19b**) within a frequency band of operation. The traveler **1920b** in FIG. **19b** is propelled by a spring **1942b**, although other forcing elements might be used. As with similar embodiments of an RFID-enabled dispenser discussed herein, in FIG. **19b**, a plunger **1944b**, acting through a

first opening **1938b**, pushes the item **1902b** to be dispensed through a second opening **1940b**.

FIG. **19c** depicts another embodiment of an RFID-enabled item dispenser **1900c**, in accordance with one or more embodiments described herein. The RFID-enabled item dispenser **1900c** is otherwise similar to the embodiment depicted in FIG. **19b**, but in which a traveler conductive layer **1935c** is inserted between the body of the traveler **1920c** and a traveler dielectric layer **1936c**. Similar to FIG. **19b**, in FIG. **19c**, a ring microstrip conductive layer **1906c** overlays a dielectric layer **1907c** on the dispenser. The ring microstrip conductive layer **1906c** forms microstrip ring antenna cells **1901c**, each having an RFID sensor **1915c**. The conductive layer **1906c** may be outside the dielectric layer **1907c** as depicted in FIG. **19c** or inside the dielectric layer **1907c** (not shown in FIG. **19c** but as depicted in FIG. **19d** with similar parts **1906d** (conductive layer) and **1945d** (dielectric or insulating layer)). Similar to other embodiments discussed herein, a plunger **1944c** may act through a first opening **1938c** to propel items **1902c** through a second opening **1940c**. The traveler **1920c** activated by a spring **1942c**, forces the items **1902c** upwards toward the second opening **1940c**. The position of the traveler **1920c** and the traveler conductive layer **1935c** activates a particular microstrip ring antenna cell **1916c** to send and receive signals to and from an interrogator (not depicted in FIG. **19c**) within a frequency band of operation.

FIG. **19d** depicts yet another embodiment of an RFID-enabled item dispenser **1900d**, otherwise similar to the embodiments of FIGS. **19b** and **19c**, in which a traveler conductive surface **1935d** folded around the traveler dielectric layer **1936d** provides a ground plane with a short on traveler **1920d**. In FIG. **19d**, an insulating layer **1945d** overlays a ring microstrip conductive layer **1906d** on the dispenser. The ring microstrip conductive layer **1906d** forms microstrip ring antenna cells **1901d**, each having an RFID sensor **1915d**. The design with the ring microstrip conductive layer **1906d** on the inside of the insulating layer **1945d** and the traveler design may allow one to make the microstrip ring antenna cells **1901d** and the RFID-enabled item dispenser **1900d** more compact than in other embodiments. Similar to other embodiments discussed herein, a plunger **1944d** may act through a first opening **1938d** to move or propel items **1902d** through a second opening **1940d**. The traveler **1920d** activated by a forcing element such as a spring **1942d**, propels the items **1902d** upwards toward the second opening **1940d**. The position of the traveler **1920d** and the traveler layers **1935d**, **1936d** activates a particular microstrip ring antenna cell **1916d** to send and receive signals to and from an interrogator (not depicted in FIG. **19d**) within a frequency band of operation.

FIG. **19e** depicts another embodiment in accordance with the present disclosure. An RFID-enabled dispenser **1900e** has a cylindrical structure **1909e**, with a circular cross-section **1905e** and a hollow interior region **1903e**. A top layer of ring microstrip antennas **1901e** are wrapped around the circumference of cylindrical structure **1909e**. The ring microstrip antennas **1901e** are each attached to an RFID circuit **1915e**. The cylindrical structure **1909e** optionally has an insulating layer **1908e**. A ground plane typically associated with ring microstrip antennas **1901e** is absent in the embodiment depicted in FIG. **19e**, except as provided by a traveler **1920e**. The traveler **1920e** may have an optional traveler dielectric layer **1937e** that surrounds a traveler conductive layer **1935e**. The traveler **1920e** is displaced due to a forcing element, such as a spring (not depicted in FIG. **19e**) or as described in other embodiments described herein, when items (not depicted in FIG. **19e**) are removed or added. The position of the traveler

1920e allows the traveler conductive layer **1935e** to provide a ground plane to a particular microstrip antenna **1916e**, to enable the particular microstrip antenna **1916e** and allow the RFID circuit attached to the particular microstrip antenna **1916e** to send and receive signals to and from an interrogator. The interrogator and a processor operate as described herein with respect to other RFID-enabled item dispensers, but are not specifically shown in FIG. **19e**.

FIG. **19f** is an illustration of an RFID-enabled item dispenser **1900f** in accordance with one or more embodiments of the present disclosure in which a top conductive layer **1908f** of one or more microstrip antennas **1901f** is wrapped around a cylinder **1909f** with circular cross-section **1905f**. As in previously described embodiments, a traveler (not depicted in FIG. **19f**) provides the ground plane associated with the top conductive layer **1908f** to form a completed microstrip antenna conformal to the cylinder **1909f**. A loop **1914f** with an RFID integrated circuit **1915f** is preferably placed in the gap of each antenna **1901f** as depicted in FIG. **19f**. In one embodiment, the microstrip antenna **1901f** is resonant at approximately one-half wavelength. A traveler mechanism, including the traveler, a forcing element, and a dispensing mechanism would operate as described with respect to other embodiments described herein but is not shown in FIG. **19f**.

FIGS. **20**, **21**, **22**, and **23a-c** illustrate one or more embodiments of the present disclosure in the form of a pressure sensor glove **2005**. Referring first to FIG. **20**, the “palm” **2000** side of a pressure sensor glove **2005** comprises ring elements **2010** positioned on foam pads **2015**. The foam pads **2015** are placed at various locations on the palm and digits (i.e., in the areas for the fingers and the thumb), as depicted in FIG. **20**, to yield desired sensitivity such that when a ring element **2010** is depressed, the ring element **2010** couples to a source, such as a first microstrip line **2115** or a second microstrip line **2120** (both depicted in FIG. **21**). The first microstrip line **2115** would be visible in FIG. **20**, but it is hidden under a layer of the glove. On the palm side of the glove, the first microstrip line **2115** may terminate with load elements close to the ring elements situated on the palm. An RFID circuit **2020** is attached to each ring element **2010**. FIG. **21** depicts the other side **2100** of the glove, in other words, the back or top side of the glove **2005**, in accordance with one or more embodiments described herein. A microstrip patch antenna **2110** is connected to the first microstrip line **2115** for coupling to the ring elements **2010** positioned on the palm and to the multiple second microstrip lines **2120** for coupling to the ring elements **2010** positioned on the digits. A load element **2125** is at the end of each second microstrip line **2120**. The load elements **2125** can comprise (for example): (1) a resistive material that absorbs incident electromagnetic (EM) energy to prevent reflections; or (2) an RFID integrated circuit (IC) that reports received power as a status on the health of the system and the amount of power coupled to ring elements **2010**. The load elements **2125** act to prevent unintended impedance mismatch. As depicted in FIG. **22**, an interrogator **2200**, such as a robot-based interrogator, can communicate with the pressure sensor glove **2005** wirelessly, thus eliminating cable runs across joints. A processor (not depicted) may be in communication with the interrogator **2200** to analyze information received by the interrogator **2200**.

The “glove” **2005** could take the form of an artificial hand or other gripping tool, as well as a glove that can be removed from a human or mechanical hand. Similarly, although human hands typically have four fingers and one thumb (designed to be an opposing thumb), the glove **2005** of the

present disclosure may be designed with a different number or type of digits, if it would be advantageous for a particular application, for example.

FIGS. **23a-23c** each depict a different detailed embodiment of components on the digits of the glove **2005** of FIGS. **20-22**, with similar arrangements also available for use on the palm (not shown). In FIG. **23a**, a dipole antenna **2305** with direct coupling to depressed rings **2310** is used. The dipole antenna **2305** is partially disposed on the surface of the digit opposite to the positioning of ring elements **2310**. The dipole antenna **2305** may include meandered lines to achieve resonance. In operation, when one or more of the ring elements **2310** are depressed, the depressed ring element **2310** directly couples with the dipole antenna **2305**. The RFID circuit **2020** on the depressed ring element **2310** is correspondingly energized. The RFID circuit **2020** sends information via the dipole antenna **2305** to the interrogator **2200** and the associated processor for further analysis.

Alternatively, in FIG. **23b**, a top antenna **2320** is placed on top of the digit of the glove **2005**. (Note the position of the top antenna **2320** relative to the load element **2125**.) The top antenna **2320** may, for example, comprise a microstrip patch or a planar inverted “F” antenna. In operation, when one or more of the ring elements **2010** are depressed, the RFID circuit **2020** on the depressed ring element **2010** (or elements) is energized. The energized RFID circuit **2020** sends a response via the top antenna **2320** to the interrogator **2200** and the processor for analysis.

FIG. **23c** depicts another alternate embodiment wherein the antenna is remote from the digit (and thus not depicted in FIG. **23c**). In this embodiment, the second microstrip line **2120** may be connected to the antenna or the interrogator. In operation, when one or more of the ring elements **2010** are depressed, the RFID circuit **2020** on the depressed ring element **2010** (or elements) is energized. The energized RFID circuit **2020** sends a response via the remote antenna to the interrogator **2200** and the processor for analysis.

FIGS. **24-27** depict another group of embodiments of the present disclosure. FIG. **24** is a diagram of a prototype of one embodiment. In the diagram of FIG. **24**, a microstrip transmission line in a loop **2400** creates a circuit with an RFID sensor **2410**. Collectively the transmission line **2400**, circuit and RFID sensor **2410** are called an RFID tag **2420**. The microstrip transmission line loop **2400** of FIG. **24** is printed on a 20 mil thick piece of hydrocarbon ceramic laminate manufactured by the Rogers Corporation and sold commercially as RO 4350. In this prototype, the RFID sensor **2410** comprises an Alien® Higgs-3 SOT sold commercially by Alien Technology of Margan Hill, Calif. While the loop **2400** is shown as being rectangular, other shapes (square or oval for example) could also be used.

FIG. **25** is a diagram of components of a prototype of another embodiment of the present disclosure. In the diagram of FIG. **25**, a 50 ohm load **2510** is connected to a board structure comprising a second microstrip transmission line **2515**, with an RF feed **2520** on the opposing end of the second microstrip transmission line **2515**. The RF feed **2520** is connected to an RFID interrogator (not shown in FIG. **25**) for this prototype, but alternatively, an antenna could be used to receive and transmit signals from and to an RFID interrogator, which may have an internal processor or may be connected to an external processor such as a laptop or desktop computer. The second microstrip transmission line **2515** in FIG. **25** is printed on a second base **2530** of a 175 mil thick, ceramic-filled polytetrafluoroethylene (PTFE) composite material sold by the Rogers Corporation commercially as RO 3003. The 50 ohm load **2510** prevents development of a

21

standing wave pattern. The RFID tags **2420** of FIG. **24** are placed on a substrate **2525**, such as a one half inch thick foam block, face down. The RFID tags **2420** are bonded or otherwise fastened to the substrate **2525** to form this component of the prototype.

FIG. **26** is a diagram of the proper placement of the components shown in FIG. **25**. Specifically, in the diagram of FIG. **26**, proper placement of the substrate **2525** with respect to the second transmission line **2515** is depicted. (The second transmission line **2515** is not visible in FIG. **26** or FIG. **27**, but its position can be determined by the position of the load **2510** and the RF feed **2520**, which can be seen in FIGS. **26** and **27**.) The substrate **2525** bearing the RFID tags **2420** is lined up such that that the top of the RFID tags **2420** line up with the bottom edge of the second microstrip transmission line **2515**, but the RFID tags **2420** do not lay across the top of the second microstrip transmission line **2515** (which, again, is not visible in FIG. **26**, as it is covered by the substrate **2525**).

FIG. **27** contains an illustration of the prototype of FIGS. **24-26** combined with a screen shot of software displaying the results of a test of the prototype. Near the top of FIG. **27**, a schematic diagram depicts that the substrate **2525** is properly positioned over the second transmission line **2515**, leaving part of the second base **2530** exposed. Near the top of FIG. **27**, a schematic diagram of a hand **2700** with two fingers **2705** extended is shown depressing the first and third RFID tags **2710** and **2715**. In general, RFID tags **2420** are only energized and thus are only read when depressed, and multiple RFID tags **2420** may be read at one time, or in succession so quickly that to the user the reading is seemingly occurring at the same time. Software such as the multi-reader software sold as Speedway® Gen2 RFID sold commercially by Impinj, Inc., installed on a processor connected to the RF feed, displays readings from depressed tags. A software display **2720** is depicted in the screenshot of FIG. **27**. The display in the screenshot depicts a line for each of the fifteen RFID tags **2420** shown in FIG. **27**. If an RFID tag **2420** is not being read, the line for that RFID tag **2420** is red in color. Lines representing the RFID tags being read (**2710** and **2715** in this illustration) are displayed in the color white. The first line **2725** and the third line **2730** in the screenshot of FIG. **27** are outlined. On the display, the software provides relevant information from the depressed RFID tags **2420** in a black font with a white background. In this illustrated example, the first and third lines **2725** and **2730**, respectively, are providing relevant information, indicating that depression of the corresponding tags **2710** and **2715** are being read successfully.

FIG. **28** depicts a diagram of a ring sensor **2800** which may be used in various embodiments described herein. The ring sensor **2800** may comprise a source element **2802** such as a microstrip waveguide or a type of antenna and a conductive ring **2804** connected to an RFID integrated circuit **2806**. While the conductive ring **2804** of FIG. **28** is represented as having a predominantly rectangular shape, the loop of conductive ring **2804** may comprise a variety of other shapes, such as circular, elliptical, triangular, square, trapezoidal, polygonal, or any other shape suitable for performing the function of indicating a position in relation to the source element **2802**.

FIG. **29a** depicts a diagram of a ring sensor **2900a**, which may be used in various embodiments described herein. The ring sensor **2900a** comprises a source element **2902**, which might be a microstrip waveguide or a type of antenna, and a conductive ring **2904a** connected to an RFID integrated circuit **2906a**. An RFID interrogator (shown generally in FIG. **1** as interrogator **145** although not shown in FIG. **29a**) communicates with the RFID integrated circuit **2906a** when the

22

position and rotation of the ring **2904a** is suitable for coupling to the source element **2902**. In this general sense, the source element **2902** and ring **2904a** can be used as a sensor to detect when the ring **2904a** has been moved laterally into the enabling position (as shown), vertically, or in general a combination of lateral and vertical positioning (both not shown). In addition, the ring **2904a** will not generally couple well when the orientation of the ring edges are not predominantly aligned with the source element **2902**. For example in FIG. **29a**, the ring **2904a** will couple to the source element **2902**, whereas in FIG. **29b**, the ring **2904b** has been rotated about an x-axis such that it no longer couples with the source element **2902**. While the conductive ring **2904a** of FIG. **29a** and the conductive ring **2904b** of FIG. **29b** are each represented as having a predominantly rectangular shape, the conductive rings **2904a** and **2904b** of FIGS. **29a-29b** may have a variety of other shapes, such as circular, elliptical, triangular, square, trapezoidal, polygonal, or any other shape suitable for performing the function of indicating a position in relation to the source element **2902**.

FIGS. **30a** and **30b** are diagrams of a two-part RFID ring tag **3000** used as a sensor to detect whether a hinged door is in an open or closed position, with FIG. **30b** comprising a diagram of the two-part RFID ring tag **3000** installed on a door hinge. The two-part RFID ring tag **3000** comprises a ring circuit **3005** and an antenna **3010**. When the two-part RFID ring tag **3000** door is installed on the door hinge as depicted in FIG. **30b** and the door is closed, the ring circuit **3005** is suitably close to the antenna **3010** such that the antenna **3010** couples energy to the ring circuit **3005**. An interrogator (shown generally as interrogator **145** of FIG. **1** although not depicted in FIG. **30a** or **30b**) is able to send information to, and receive information from, the energized ring circuit **3005** of the two-part RFID ring tag **3000**, signaling that the door is closed.

FIGS. **31a** and **31b** depict another embodiment described herein. In this embodiment, a ring sensor **3100** is used as a switch. The ring sensor or switch **3100** comprises a ring tag **3104** with an RFID integrated circuit **3106** operatively connected thereto. The ring tag **3104** is attached to a membrane **3103** that pivots about a rotational axis **3110**. In FIG. **31a**, the membrane **3103** is in the “off” state such that the ring tag **3104** is not enabled to couple energy to and from a source element **3102**, which might be, for example, a meandered dipole or a microstrip patch antenna. When the membrane **3103** is rotated about the rotational axis **3110**, as shown in FIG. **31b**, however, the ring tag **3104** is enabled and can receive energy from, or transmit energy to, an interrogator (shown generally as interrogator **145** of FIG. **1** although not shown in FIG. **31a** or **31b**). The membrane **3103** may be fastened at one or both ends by a latch, a hook-and-loop fastener (commonly referred to as “Velcro”), a magnet, or any of a number of other fastening elements, including an adhesive (although not depicted in FIG. **31a** or **31b**). The membrane **3103** might be an insulating fabric or rigid insulating element. In one embodiment, the membrane **3103** comprises a strip of insulating fabric, the source element **3102** comprises a fabric antenna, and a section of a hook-and-loop fastener is used to fasten the end of the membrane **3103** in either the “off” or “on” position. An array of similar switches may be worn on a shirt and used to communicate commands or other information to a processor through an RFID interrogator.

Any of a number of other switch mechanisms is possible with a variety of options to captivate the ring sensor in both “off” positions, which disable communications to the tag, and “on” positions, which enable communications to a tag.

In light of the principles and exemplary embodiments described and illustrated herein, it will be recognized that the exemplary embodiments can be modified in arrangement and detail without departing from such principles. Also, the foregoing discussion has focused on particular embodiments, but other configurations are contemplated. In particular, even though expressions such as “in one embodiment,” “in another embodiment,” “in a version of the embodiment” or the like are used herein, these phrases are meant to generally reference the range of possibilities of embodiments, and are not intended to limit the disclosure to the particular embodiments and configurations described herein. As used herein, these terms may reference the same or different embodiments that are combinable into other embodiments.

Similarly, although exemplary processes have been described with regard to particular operations performed in a particular sequence, numerous modifications could be applied to those processes to derive numerous alternative embodiments of the present disclosure. For example, alternative embodiments may include processes that use fewer than all of the disclosed operations, processes that use additional operations, and processes in which the individual operations disclosed herein are combined, subdivided, rearranged, or otherwise altered.

In view of the wide variety of useful permutations that may be readily derived from the exemplary embodiments described herein, this detailed description is intended to be illustrative only, and should not be taken as limiting the scope of the disclosure. What is claimed as the disclosure, therefore, are all implementations that come within the scope of the following claims, and all equivalents to such implementations. In the claims, means-plus-function and step-plus-function clauses are intended to cover the structures or acts described herein as performing the recited function and not only structural equivalents, but also equivalent structures. Thus, while a nail and a screw may not be structural equivalents in that a nail employs a cylindrical surface to secure wooden parts together, whereas a screw employs a helical surface, in the environment of fastening wooden parts, a nail and a screw may be equivalent structures.

What is claimed is:

1. A system for radio frequency identification (RFID)-enabled information collection comprising:
 - one or more ring elements, each ring element including a conductive ring connected to an RFID integrated circuit; at least one source element;
 - an interrogator capable of transmitting a signal to the source element; and
 - at least one of the conductive rings capable of coupling to its source element when the conductive ring is in a first position and orientation, energizing the RFID circuit associated with the conductive ring to respond; and

- a processor in communication with the interrogator and capable of deriving information regarding the positions and orientations of the one or ring elements relative to the one or more source elements.
- 2. The system of claim 1, wherein the source element comprises an antenna element.
- 3. The system of claim 1, wherein the source element comprises an open waveguide such that the ring element can couple to the waveguide structure when it is in the proper position and orientation.
- 4. The system of claim 1, wherein the conductive ring and the source element are placed on door components such that the conductive ring couples to the source element only when the door is in a first position.
- 5. The system of claim 1, wherein the conductive ring has a shape selected from group comprising circular, elliptical, triangular, rectangular, trapezoidal, and other polygonal.
- 6. An apparatus for radio frequency identification (RFID)-enabled information collection comprising:
 - one or more ring elements, each ring element including a conductive ring connected to an RFID integrated circuit; and
 - at least one source element, responsive to a signal from an interrogator and capable of transmitting a responding signal from the RFID integrated circuit when energized; wherein at least one of the conductive rings is capable of coupling to its corresponding source element when the conductive ring is in a first position and orientation, energizing the RFID circuit associated with the conductive ring to respond; and
 - wherein the responding signal from the RFID integrated circuit is capable of being analyzed by a processor in communication with the interrogator, the responding signal containing information regarding the positions and orientations of the one or ring elements relative to the one or more source elements.
- 7. The system of claim 6, wherein the source element comprises an antenna element.
- 8. The system of claim 6, wherein the source element comprises an open waveguide such that the ring element can couple to the waveguide structure when it is in the proper position and orientation.
- 9. The system of claim 6, wherein the conductive ring and the source element are placed on door components such that the conductive ring couples to the source element only when the door is in a first position.
- 10. The system of claim 6, wherein the conductive ring has a shape selected from group comprising circular, elliptical, triangular, rectangular, trapezoidal, and other polygonal.

* * * * *