

NASA/CR-2016-219200



# Application of Strategic Planning Process with Fleet Level Analysis Methods

Final Report

*Dimitri N. Mavris, Holger Pfaender, Hernando Jimenez, Elena Garcia,  
Eric Feron, and Jose Bernardo  
Georgia Institute of Technology, Atlanta, Georgia*

---

May 2016

## NASA STI Program . . . in Profile

Since its founding, NASA has been dedicated to the advancement of aeronautics and space science. The NASA scientific and technical information (STI) program plays a key part in helping NASA maintain this important role.

The NASA STI program operates under the auspices of the Agency Chief Information Officer. It collects, organizes, provides for archiving, and disseminates NASA's STI. The NASA STI program provides access to the NTRS Registered and its public interface, the NASA Technical Reports Server, thus providing one of the largest collections of aeronautical and space science STI in the world. Results are published in both non-NASA channels and by NASA in the NASA STI Report Series, which includes the following report types:

- **TECHNICAL PUBLICATION.** Reports of completed research or a major significant phase of research that present the results of NASA Programs and include extensive data or theoretical analysis. Includes compilations of significant scientific and technical data and information deemed to be of continuing reference value. NASA counter-part of peer-reviewed formal professional papers but has less stringent limitations on manuscript length and extent of graphic presentations.
- **TECHNICAL MEMORANDUM.** Scientific and technical findings that are preliminary or of specialized interest, e.g., quick release reports, working papers, and bibliographies that contain minimal annotation. Does not contain extensive analysis.
- **CONTRACTOR REPORT.** Scientific and technical findings by NASA-sponsored contractors and grantees.

- **CONFERENCE PUBLICATION.** Collected papers from scientific and technical conferences, symposia, seminars, or other meetings sponsored or co-sponsored by NASA.
- **SPECIAL PUBLICATION.** Scientific, technical, or historical information from NASA programs, projects, and missions, often concerned with subjects having substantial public interest.
- **TECHNICAL TRANSLATION.** English-language translations of foreign scientific and technical material pertinent to NASA's mission.

Specialized services also include organizing and publishing research results, distributing specialized research announcements and feeds, providing information desk and personal search support, and enabling data exchange services.

For more information about the NASA STI program, see the following:

- Access the NASA STI program home page at <http://www.sti.nasa.gov>
- E-mail your question to [help@sti.nasa.gov](mailto:help@sti.nasa.gov)
- Phone the NASA STI Information Desk at 757-864-9658
- Write to:  
NASA STI Information Desk  
Mail Stop 148  
NASA Langley Research Center  
Hampton, VA 23681-2199

NASA/CR–2016-219200



# Application of Strategic Planning Process with Fleet Level Analysis Methods

## Final Report

*Dimitri N. Mavris, Holger Pfaender, Hernando Jimenez, Elena Garcia,  
Eric Feron, and Jose Bernardo  
Georgia Institute of Technology, Atlanta, Georgia*

National Aeronautics and  
Space Administration

Langley Research Center  
Hampton, Virginia 23681-2199

Prepared for Langley Research Center  
under Contract NNL12AA14C

---

May 2016

The use of trademarks or names of manufacturers in this report is for accurate reporting and does not constitute an official endorsement, either expressed or implied, of such products or manufacturers by the National Aeronautics and Space Administration.

Available from:

NASA STI Program / Mail Stop 148  
NASA Langley Research Center  
Hampton, VA 23681-2199  
Fax: 757-864-6500

# Table of Contents

<b>1. INTRODUCTION</b>	<b>1</b>
1. BACKGROUND	1
2. PROGRAM DESCRIPTION	3
1. <i>Task 1: Fleet Level Technology Trade Study</i>	3
2. <i>Task 2: Incorporating Safety Constraints into System-Wide Cost-Benefit Analysis of Environmental Impact</i>	6
3. <i>Task 3: Strategic Planning and Prioritization Calculator</i>	8
<b>2. FLEET LEVEL MODELING</b>	<b>10</b>
1. BACKGROUND	10
2. FLEET LEVEL MODELING TOOLS	10
1. <i>GREAT</i>	10
2. <i>IDEA</i>	19
3. AIRCRAFT MODELING	19
1. <i>Fuel Burn</i>	20
2. <i>NOx</i>	20
3. <i>Noise</i>	21
4. FLEET EVALUATION SCENARIOS	21
1. <i>Technology Scenarios</i>	22
2. <i>Aircraft Configuration Scenarios</i>	28
3. <i>Fleet Replacement Schedule</i>	28
5. EDS FLEET VEHICLE PERFORMANCE	32
6. VEHICLE COEFFICIENTS FOR FLEET ASSESSMENT	41
<b>3. SAFETY ANALYSIS</b>	<b>42</b>
1. MOTIVATION AND PURPOSE	42
2. SCOPE AND STATE OF UNDERSTANDING	42
3. SAFETY ASSESSMENT METHOD	43
4. VEHICLE CONCEPTS AND TECHNOLOGIES	46
5. TUBE AND WING VEHICLE CHARACTERISTICS	48
6. HYBRID WING BODY VEHICLE CHARACTERISTICS	48
7. BOX WING VEHICLE CHARACTERISTICS	50
8. MID FUSELAGE NACELLE VEHICLE CHARACTERISTICS	53
9. HAZARDS IDENTIFICATION	55
1. <i>Taxi in / out</i>	55
2. <i>Takeoff</i>	57
3. <i>Climb</i>	60
4. <i>Cruise</i>	61
5. <i>Descent</i>	62
6. <i>Final Approach</i>	64
7. <i>Landing</i>	66
10. COMMON HAZARDS AND CONTRIBUTING FACTORS	68
11. TECHNOLOGY HAZARD ASSESSMENT	69
1. <i>Individual Technologies</i>	69

2.	<i>Cross-Technology Hazards</i> .....	71
12.	SAFETY METRIC PROXIES AND HAZARD QUANTIFICATION .....	73
1.	<i>Taxi-in</i> .....	73
2.	<i>Wing Span &amp; Vapp</i> .....	73
13.	TAKEOFF .....	74
1.	<i>Runway Overrun</i> .....	74
2.	<i>Balanced Field Length (BFL), Decision Speed</i> .....	75
3.	<i>W, T, <math>\rho</math>, runway slope, runway conditions</i> .....	80
14.	CLIMB.....	80
1.	<i>Wake Vortex Hazard</i> .....	80
2.	<i>Wake generation</i> .....	81
3.	<i>Vortex Strength <math>\Gamma</math>, Tangential Velocity Induced <math>V_{\theta}</math></i> .....	82
4.	<i>Wake Encounter</i> .....	85
5.	<i>Maximum Roll Induced Coefficient (<math>C_l</math>)</i> .....	86
6.	<i><math>\Gamma, b, V_{\infty}, \alpha, C_{L\alpha}</math></i> .....	87
7.	<i>Stall</i> .....	88
8.	<i>Stall Margin</i> .....	89
9.	<i>Wind Shear Hazard</i> .....	90
10.	<i>Climb Angle, Climb Speed and Climb Rate</i> .....	93
11.	<i>Altitude, Speed (<math>V</math>), Thrust (<math>T_{av}</math>), Drag, Weight</i> .....	94
12.	<i>Loss of Separation</i> .....	94
13.	<i>Separation in terms of <math>T_{delay}</math></i> .....	95
14.	<i>Mission Segment Details from FLOPS</i> .....	96
15.	CRUISE.....	99
1.	<i>Loss of Separation due to High/Low Cruise Rates</i> .....	99
2.	<i>Cruise Speed</i> .....	99
16.	DESCENT AND APPROACH .....	100
1.	<i>Un-Stabilized Approach</i> .....	102
2.	<i>Flight path angle and rate of sink</i> .....	102
3.	<i>Go-around capability</i> .....	103
4.	<i>Decision Height</i> .....	104
5.	<i>Vapp, Tdelay, Flight Path angle <math>\gamma</math>, <math>n_{limit}</math></i> .....	104
6.	<i>Wind Shear Hazard</i> .....	105
7.	<i>Descent Angle, Descent Speed and Descent Rate</i> .....	106
8.	<i>Altitude, Speed (<math>V</math>), Thrust (<math>T</math>), Drag (<math>D</math>), Weight (<math>W</math>)</i> .....	106
9.	<i>Stall Margin</i> .....	107
10.	<i>Engine Stall</i> .....	107
11.	<i>(BWB) Engine Performance, Engine Integration and Engine Location (Qualitative)</i> .....	107
17.	LANDING .....	108
1.	<i>Runway excursion and centerline deviations</i> .....	108
2.	<i>Simultaneous runway occupancy / Runway collisions</i> .....	109
3.	<i>Crosswind landing (Wing Tip Strike)</i> .....	109
4.	<i>Bank Angle and Clearance.</i> .....	111
18.	SAFETY ATC PERFORMANCE MODELING .....	112

1.	<i>Introduction</i> .....	112
2.	<i>Fleet Composition and Characteristic Speeds</i> .....	113
3.	<i>Fleet Evolution and Fleet Scenarios</i> .....	114
4.	<i>The Encounter Rate Model</i> .....	116
5.	<i>General Implementation for NAS-wide Estimate</i> .....	119
6.	<i>Implementation for Sector Encounter Rate</i> .....	121
7.	<i>Implementation for Approach in Terminal Area</i> .....	124
8.	<i>Summary of Findings</i> .....	128
<b>4.</b>	<b>STRATEGIC PLANNING AND PRIORITIZATION CALCULATOR</b> .....	<b>129</b>
1.	DASHBOARD OVERVIEW .....	130
2.	VEHICLE TECHNOLOGY DASHBOARD .....	133
3.	PROBABILISTIC VEHICLE ANALYSIS DASHBOARD .....	135
4.	FLEET LEVEL DASHBOARD FUEL BURN AND NOX.....	137
5.	FLEET LEVEL NOISE .....	138
1.	<i>Development of a Rapid Fleet-Level Noise Computation Model [Bernardo May 2015]</i> .....	139
2.	<i>Probabilistic Assessment of Fleet-Level Noise Impacts of Projected Technology Improvements</i> <i>144</i>	
3.	<i>Application of Mixture Design of Experiments for Dynamic Fleet-Level Evaluation of Multi-Objective Environmental Technology Trade-offs [Bernardo 2014]</i> .....	151
4.	<i>A Multi-Stage Surrogate Modeling Approach to Examine Vehicle-Level Technology Impacts at the Airport-Level [Bernardo, Jan. 2015]</i> .....	158
5.	<i>Development of Generic Airport Categories for Rapid Fleet-Level Noise Modeling [Bernardo, Jun. 2015]</i> .....	166
<b>5.</b>	<b>RESULTS</b> .....	<b>170</b>
1.	FLEET LEVEL RESULTS .....	171
1.	<i>Scenario Fuel Burn Results</i> .....	171
2.	<i>Scenario Total NOx Results</i> .....	179
3.	<i>Scenario Local NOx Results</i> .....	182
4.	<i>Scenario Noise Results</i> .....	184
5.	<i>IDEA Results</i> .....	186
<b>6.</b>	<b>CONCLUSIONS</b> .....	<b>189</b>
<b>7.</b>	<b>REFERENCES</b> .....	<b>191</b>

Figure 1: Forecast of U.S. Commercial Aviation Operations [FAA 2013] .....	11
Figure 2: Diagram of retirements algorithm (top), and replacements algorithm (bottom). .....	16
Figure 3. Engine FPR and Efficiency Schedule.....	23
Figure 4. Wing AR and Gust load Schedule.....	24
Figure 5. Technology Portfolio Impacts .....	26
Figure 6 Fleet Replacement schedule from foundational model .....	28
Figure 7 Fleet Replacement schedule foundational model for RTC technologies .....	29
Figure 8. Fleet Replacement Schedule for Scenarios RTC, ITD, ERA, and N+2 .....	29
Figure 9. Fleet Replacement Schedule for Scenario ITD UC1.....	30
Figure 10. Fleet Replacement Schedule for Scenarios ERA UC1 and N+2 UC1 .....	31
Figure 11. Fleet Replacement Schedule for Scenarios ITD UC2, ERA UC2 and N+2 UC2 .....	32
Figure 12. EDS Vehicle Performance for Fleet Scenarios - RJ Class .....	33
Figure 13. EDS Vehicle Fuel Burn Performance for Fleet Scenarios - SSA Class .....	33
Figure 14. EDS Vehicle Noise Performance for Fleet Scenarios - SSA Class.....	34
Figure 15. EDS Vehicle Emissions Performance for Fleet Scenarios - SSA Class.....	34
Figure 16. EDS Vehicle Fuel Burn Performance for Fleet Scenarios - LSA Class.....	35
Figure 17. EDS Vehicle Noise Performance for Fleet Scenarios - LSA Class.....	35
Figure 18. EDS Vehicle Emissions Performance for Fleet Scenarios - LSA Class .....	36
Figure 19. EDS Vehicle Fuel Burn Performance for Fleet Scenarios - STA Class.....	36
Figure 20. EDS Vehicle Noise Performance for Fleet Scenarios - STA Class.....	37
Figure 21. EDS Vehicle Emissions Performance for Fleet Scenarios - STA Class .....	37



Figure 22. EDS Vehicle Fuel Burn Performance for Fleet Scenarios - LTA Class.....	38
Figure 23. EDS Vehicle Noise Performance for Fleet Scenarios - LTA Class .....	38
Figure 24. EDS Vehicle Emissions Performance for Fleet Scenarios - LTA Class .....	39
Figure 25. EDS Vehicle Fuel Burn Performance for Fleet Scenarios - VLA Class.....	39
Figure 26. EDS Vehicle Noise Performance for Fleet Scenarios - VLA Class.....	40
Figure 27. EDS Vehicle Emissions Performance for Fleet Scenarios - VLA Class.....	40
Figure 28 Geometric Model of the tube and wing aircraft .....	48
Figure 29 Geometric Model of the Hybrid Wing Body aircraft.....	50
Figure 30 Geometric Model of the Box Wing aircraft .....	53
Figure 31 Geometric model of the B027 aircraft.....	54
Figure 32 Rejected Take Off (RTO) causes [FAA Pilot Safety] .....	75
Figure 33 FAR requirements for Runway Length [FAA Pilot Safety].....	76
Figure 34 Balanced Field Length and Decision Speed for TRC T&W .....	77
Figure 35 Balanced Field Length and Decision Speed for ITD HWB .....	78
Figure 36 Balanced Field Length and Decision Speed for ITD BXW .....	78
Figure 37 Balanced Field Length and Decision Speed for ITD MFN.....	79
Figure 38 Wake Vortex [Skybrary 2015] .....	81
Figure 39 Vortex pair with vorticity radius $r_v$ , vortex core radius $r_c$ , lateral distance $s_{ob}$ [Liu 2007].....	82
Figure 40 Wake vortex characteristic velocities for the HWB compared to T&W .....	84
Figure 41 Wake vortex characteristic velocities for the MFN compared to T&W .....	85
Figure 42 Aircraft encountering the wake vortex [Liu 2007].....	86
Figure 43 Rolling Moment Coefficient at different downstream distances.....	88

Figure 44 Pitch Attitude [Boeing 2015].....	90
Figure 45 Aircraft Upset Conditions.....	91
Figure 46 Effect on Flight Path Angle and ROC due to head wind [Lowry 1999] .....	91
Figure 47 Effect on Flight Path Angle and ROC due to head wind and down draft [Lowry 1999] .....	92
Figure 48 Separation Requirements.....	96
Figure 49 Climbout profile for advanced Regional Jet and advanced concepts.....	97
Figure 50 Loss of Separation for HWB leading TW50A .....	98
Figure 51 Loss of Separation for BXW leading TW50A .....	98
Figure 52 Loss of Separation for MFN leading TW50A.....	99
Figure 53 Distribution of Accidents according to Mission phase [Boeing 2011] .....	101
Figure 54 Go around analysis - Decision Height.....	104
Figure 55 Sink rate and decision height vs. approach speed for fixed flight path angle and load factor .....	105
Figure 56 flight path angle and decision height vs. approach speed for fixed sink rate and load factor .....	105
Figure 57 Distorsion Levles For Various Inlet Designs [Daggett 2007].....	108
Figure 58 Modeling Runway overrun operations .....	109
Figure 59 Cross Wind Approach Techniques [Flight Safety Foundation 2000] .....	110
Figure 60 Cross Wind Landing [Flight Safety Foundation 2000] .....	111
Figure 61 Wing banking clearance for the RTC T&W.....	112
Figure 62 Wing banking clearance for the ITD HWB.....	112
Figure 63 Reference Technology Collector (RTC) Scenario (Baseline).....	115

Figure 64. ERA Unconventional Configuration Scenario (ERA) .....	116
Figure 65. Horizontal swept area for horizontal encounter rate .....	118
Figure 66 NAS-wide US fleet composition and evolution over time.....	120
Figure 67 Encounter rate (bars) and traffic volume (trend line) for entire NAS .....	120
Figure 68. Sensitivity analysis of ERA aircraft cruise speed on the NAS encounter rate .....	121
Figure 69 Intersection of two airways with angle $\alpha$ and intersection area $A_{m,n}$ .....	122
Figure 70. Trajectory data for ZOB and results of clustering approach .....	123
Figure 71 Encounter rate for overpass and intersections in selected paths for ZOB airspace .....	124
Figure 72. FLCON Arrival at ATL.....	125
Figure 73. Fleet mix for ATL FLCON .....	125
Figure 74. Encounter rate for ATL FLCON arrival fix .....	127
Figure 75. Sensitivity analysis of fleet composition for ATL FLCON arrival.....	128
Figure 76. Sensitivity study with speed perturbation.....	128
Figure 77. Original Microsoft Excel Version of Dashboard.....	129
Figure 78. Dashboard Technology Assessment Levels .....	130
Figure 79. Information Generation and Flow to the ERA Dashboard.....	132
Figure 80 ERA Dashboard screenshot.....	133
Figure 81: Updated Geometry Based on Selected Technology Package.....	134
Figure 82: 7,000 Technology Packages Including Pareto Frontier for Selected Vehicle	135
Figure 83: Probabilistic Analysis Contour Plots for Selected Technology Package .....	136
Figure 84: Replacement Schedule for Fleet Local NOx.....	137

Figure 85: 65 dB Contour for Defined Fleet Scenario.....	139
Figure 86. The steps of the model for rapidly calculating airport-level noise.....	142
Figure 87. Analysis methodology. Approach enables rapid tradeoffs of system-level technology impacts to noise.....	145
Figure 88. Actual and residual by predicted. Fit and validation cases both included....	147
Figure 89. Model representation error. Error distribution approximates a Gaussian distribution.....	147
Figure 90 Mixture-of-Mixtures. Process variables also impact the mixture-of-mixture space.....	152
Figure 91 Approach summary. Vehicle-level and airport-level surrogates combine to predict vehicle-level impacts on the contour. ....	164
Figure 92 Summary of airport grouping strategy. ....	169
Figure 115 FAA Forecast changes in RPM.....	172
Figure 116 FAA domestic and international forecast in system RPM.....	173
Figure 93 Business as Usual Comparison of Fuelburn with different Forecasts.....	174
Figure 94 Comparison of Business as usual to Reference Technology Collector in terms of fuel burn.....	174
Figure 95 Comparison of ITD scenarios in terms of fuel burn.....	175
Figure 96 Comparison of ERA scenarios in terms of fuel burn.....	176
Figure 97 Comparison of N+2 scenarios in terms of fuel burn.....	177
Figure 98: All fleet scenarios in terms of fuel burn.....	177
Figure 99 Comparison of forecasts and vehicles in terms of fuel burn.....	178
Figure 100 Comparison of ITD scenarios in terms of NOx.....	179

Figure 101 Comparison of ERA scenarios in terms of NO <sub>x</sub> .....	180
Figure 102 Comparison of N+2 scenarios in terms of NO <sub>x</sub> .....	180
Figure 103 All Scenarios Fleet Level Total NO <sub>x</sub> .....	181
Figure 104 Comparison of ITD scenarios in terms of local NO <sub>x</sub> .....	182
Figure 105 Comparison of ERA scenarios in terms of local NO <sub>x</sub> .....	183
Figure 106 Comparison of N+2 scenarios in terms of local NO <sub>x</sub> .....	183
Figure 107 All fleet scenarios in terms of local NO <sub>x</sub> .....	184
Figure 108 Medium airport 55 DNL contour for 2030.....	184
Figure 109 Medium airport 55 DNL contour for 2050.....	185
Figure 110 Medium airport 65 DNL contour for 2030.....	185
Figure 111 Medium airport 65 DNL contour for 2050.....	185
Figure 114 EIA Annual Energy Outlook (AEO) jet fuel price.....	186
Figure 112 Low technology (a) low fuel price; (b) high fuel price scenarios .....	187
Figure 113 High technology (a) low fuel price; (b) high fuel price scenarios.....	188
Figure 114 ITD Technology (a) Low fuel price; (b) High fuel price scenarios .....	189

# 1. Introduction

## 1. Background

Commercial air transport activity forecasts continue to predict steady growth over the next few decades despite recent decline and ongoing fluctuations in activity. Accordingly, a myriad of environmental goals have been proposed by government agencies, intergovernmental bodies, and industry consortia in an effort to mitigate the environmental impact of growing aviation activity. Strategic guidance and policy for research have been typically issued alongside these goals in order to identify and develop solutions towards achieving the goals in question. Goals for fuel consumption and corresponding CO<sub>2</sub> emissions reduction have been articulated in different ways, although recently the notion of carbon neutral growth has gained popularity. Guidance towards CO<sub>2</sub> reductions commonly features a variety of complementary approaches that include aircraft concepts and technologies, operational improvements, infrastructure, and the use of alternative fuels. “Wedge charts” have become ubiquitous in the summary depiction of CO<sub>2</sub> reduction contributions for system-wide assessments. A representative example is shown in Figure 1 where notional trends and CO<sub>2</sub> reduction contributions towards carbon neutral growth are notionally illustrated. Significant efforts, including that reported in this manuscript, have been dedicated to the development of quantitative models that can bring specificity to the characterization of each wedge, namely the CO<sub>2</sub> reduction contributions from each mechanism.

Among the different approaches towards carbon neutral growth aircraft concepts and technologies have yielded notable improvements over many decades. In the United States several government entities are responsible for research at the fundamental and integrated system level to identify airframe and engine technologies enabling fuel burn, emissions, and noise reductions. Efforts in this area remain the focal means towards system-wide fuel burn and emissions goals, even as

complementary approaches have been shown to be necessary to offset the effect of growing aviation activity.

An assessment of system-wide impacts resulting from the implementation of vehicle-level technology improvements is of paramount importance as it provides a quantitative mapping of performance across different levels of systemic abstraction, namely the vehicle level and the system-wide (or fleet) level.

While broader environmental impact goals are usually stated on a system-wide level, performance targets proposed by NASA for subsonic air transport are formulated at the aircraft level. NASA's goals, shown in Table 1, consider increasing degrees of improvements for three timeframes, each corresponding roughly to increasing technology generations of commercial air transports referred to as N+1, N+2, and N+3. The N+2 technology generation assumes a Technology Readiness Level (TRL) of 4-6 for key technologies by 2020 and a notional Entry Into Service (EIS) by 2025. N+2 goals are defined on the basis of a "large twin aisle reference configuration" that was later revised to specify the Boeing 777-200 with GE90 engines as a vehicle reference.

The goal of this work is to quantify and characterize the potential system-wide reduction of fuel consumption and corresponding CO<sub>2</sub> emissions, resulting from the introduction of N+2 aircraft technologies and concepts into the fleet. Although NASA goals for this timeframe are referenced against a large twin aisle aircraft we consider their application across all vehicle classes of the commercial aircraft fleet, from regional jets to very large aircraft. Prior work describes a fleet-level assessment of fuel burn and CO<sub>2</sub> emissions for ERA vehicle concepts and technologies. In this work the authors describe and discuss the formulation and implementation of the fleet assessment by addressing the main analytical components: forecasting, operations allocation, fleet retirement, fleet replacement, and environmental performance modeling. The work presented in this paper builds upon that prior work, and augments the analysis and results in three respects. First, the operations balancing and allocation logic has been revised to better match fuel burn empirical data for domestic and international operations, and by extension more accurately capture the assignment and

utilization of aircraft to flights based on aircraft seat capacity and flight distance. Second, environmental performance of vehicle concepts infused with N+2 technologies reflects updated technology portfolios, updated technology impacts modeling, and aircraft systems performance analysis modeling enhancements. Third, the underlying published operations forecasts have been updated and feature a reduced rate of growth as compared to prior years' forecasts.

## **2. Program Description**

The following tasks were agreed upon at the beginning of this study. They are addressed throughout the sections of this document, not necessarily in the same order.

### **1. Task 1: Fleet Level Technology Trade Study**

The contractor shall perform fleet level studies using the GREAT and IDEA tools. The contractor shall use GREAT to analyze forecasts produced by ICAO/CAEP and FAA. The contractor shall use IDEA to explore the feedback effect of technology on cost, demand, and environmental outcomes. The subtasks required to complete the fleet level studies using GREAT and IDEA are detailed in the following sections.

#### *1. Update Underlying Forecasts*

The contractor shall update the IDEA tool to reflect the latest domestic US and available international aviation forecasts suitable for environmental analysis including, but not limited to, the following forecasts: Terminal Area Forecast (TAF), Committee on Aviation Environmental Protection (CAEP) forecast, and Economic Support Group (FESG) forecasts.

#### *2. Define Scenarios and Portfolios*

The contractor shall, in consultation with the NASA COTR, define the advanced vehicle configurations and technology portfolios to be included in the fleet level scenario studies, determine the fleet



assessment scenarios assumptions and fleet level metrics to be tracked during the fleet level scenario studies.

3. *Replacement Vehicle Performance Database*

The contractor shall develop a performance definition database describing all the characteristics required to create a fleet of replacement vehicles. This database shall be based on the vehicle definitions obtained from the results of the ERA vehicle assessment conducted under NRA Contract No. NNL12AA12C and include the characteristics required to determine fuel burn, local (airport) Nitrogen Oxides (NO<sub>x</sub>), total NO<sub>x</sub>, and airport noise (Deliverable 4.6).

4. *Create Representation of ERA Vehicles in Fleet Level Analysis Methods*

The contractor shall use vehicle level information generated from the replacement vehicle database to create representations of the advanced vehicle concepts with technology portfolios for fuel burn, local NO<sub>x</sub>, total NO<sub>x</sub>, and noise to perform the fleet level scenario studies in section 3.1.5. The contractor shall determine the appropriate technology portfolios for their fleet level assessments based on the vehicle level results generated under NRA Contract No. NNL12AA12C.

5. *Perform Fleet Level Scenario Studies*

The contractor shall use the information generated from subtasks 3.1.2 through 3.1.4 to perform fleet level performance studies using GREAT. The contractor shall also use the information generated from subtasks 3.1.1 through 3.1.4 to perform fleet level performance studies using IDEA. The contractor shall track and report the results of these studies in terms of fuel efficiency, noise, and NO<sub>x</sub> metrics. Prior to the fleet level performance studies, the contractor shall verify the results obtained from the updated GREAT and IDEA tools by executing reference scenarios and validating the results to the same reference scenarios executed using AEDT. At the conclusion of each project year, the contractor shall submit an updated version of the IDEA tool incorporating the investigated ERA vehicles (Deliverable 4.8).

6. *Refine Scenarios and Portfolios for Year 2 & 3*

In Year 2 and 3 of the program, the contractor shall update the advanced vehicle configurations and technology portfolios to be included in the fleet level scenario studies created in task 3.1.2 based on updates generated in the vehicle assessment under NRA Contract No. NNL12AA12C. The contractor shall then update the fleet assessment scenarios and assumptions as well as the fleet level metrics to be tracked during the fleet level scenario studies.

7. *Update Vehicle Performance Database for Year 2 & 3*

In Year 2 and 3 of the program, the contractor shall utilize the updated vehicle models obtained in task 3.1.3 to update the performance definition database to describe all the characteristics necessary to create a fleet replacement vehicle.

8. *Update Representation of ERA Vehicles in Fleet Level Analysis Methods for Year 2 & 3*

In Year 2 and 3 of the program, the contractor shall utilize the updated vehicle performance obtained in task 3.1.7 to create updated representations of the advanced vehicle concepts with different technology portfolios for fuel burn, local NO<sub>x</sub>, total NO<sub>x</sub>, and noise for use in GREAT and IDEA as fleet replacement vehicles.

9. *Update Fleet Level Scenario Studies for Year 2 & 3*

In Year 2 and 3 of the program, the contractor shall utilize the information generated in subtasks 3.1.6 through 3.1.8 to perform fleet level performance studies using GREAT. The contractor shall also use the information gathered in subtasks 3.1.6 through 3.1.8 as well as updated forecasts from task 3.1.1 to perform fleet level performance studies using IDEA. Prior to the fleet level performance studies, the contractor shall verify the results obtained from the updated GREAT and IDEA tools by executing reference scenarios and comparing the results to the same reference scenarios executed using AEDT.

## **2. Task 2: Incorporating Safety Constraints into System-Wide Cost-Benefit Analysis of Environmental Impact**

The contractor shall conduct a safety analysis that examines the impact of new vehicle paradigms on air traffic management in terminal areas, novel operational procedures, and wake vortex separation. The contractor shall identify safety metrics and develop a safety modeling environment applicable to the new vehicle configurations.

### *1. Identify Scenarios for Safety ATC Performance*

The contractor shall incorporate the fleet level scenarios identified in task 3.1.2 into the ATC simulation tool. The contractor shall ensure that the considered set of safety scenarios as defined in Task 3.2.2 is representative for modeling operational procedures and vehicle characteristics.

### *2. Select Safety Metric Proxies*

The contractor shall establish proxies for safety metrics for use in safety scenario studies that are more readily measured in both operation and simulation than traditional safety metrics such as estimates of fatality and/or accident rates. The proxies shall be representative of commonly experienced and anticipated safety issues such as a violation of aircraft safety zones and exposure to aircraft wakes. These proxies shall then be used in Tasks 3.2.3 through 3.2.5 to study the effects of aircraft position uncertainty, wake encounter hazards, flexibility of operations, and increased heterogeneity of vehicles.

### *3. Safety ATC Performance Model Development*

The contractor shall develop a safety model that captures aircraft operations involving the new vehicles developed in Tasks 3.1.3 and 3.1.4. The contractor shall assess the system-wide environmental impact to the corresponding targeted levels of safety in terms of mid-air collisions due to aircraft position uncertainty and wake encounters. The contractor shall deliver the completed software product(s) and/or data to the customer with appropriate documentation to build, install, and

operate the software and/or recreate the data or analysis (Deliverable 3.9).

4. *Incorporate Fleet Allocation and Replacement Vehicle Performance*

The contractor shall incorporate the replacement vehicles defined in task 3.1.3 for use in the ATC simulation tool. The contractor shall ensure that the described vehicle performance is sufficiently detailed to enable the safety scenario studies described in section 3.2.5.

5. *Perform Safety Scenario Studies*

The contractor shall perform safety fleet level studies to examine the impact of new vehicle paradigms on air traffic management in terminal areas, novel operational procedures, and wake vortex separation. As part of the studies, the contractor shall conduct trade-offs involving individual vehicle characteristics, both inherent vehicle performance and operational constraints, and the resulting safety requirements.

6. *Refine Scenarios for Safety ATC Performance Model for Year 2 & 3*

In Year 2 and 3 of the program, the contractor shall update the scenarios identified in task 3.2.1 to incorporate the updated ERA Technology Portfolio generated under NRA Contract No. NNL12AA12C.

7. *Refine Safety Metric Proxies for Year 2 & 3*

In Year 2 and 3 of the program, the contractor shall update the safety metric proxies selected in task 3.2.2 to include additional features and capabilities as identified in the updated ERA Technology Portfolio generated under NRA Contract No. NNL12AA12C to improve characterization of safety impacts.

8. *Refine Safety ATC Performance Model for Year 2 & 3*

In Year 2 and 3 of the program, the contractor shall update the ATC performance model to include the additional features and capabilities identified in the updated ERA Technology Portfolio generated under

NRA Contract No. NNL12AA12C to improve performance prediction. The contractor shall deliver the completed software product(s) and/or data to the customer with appropriate documentation to build, install, and operate the software and/or recreate the data or analysis (Deliverable 3.9).

9. *Update Fleet Allocation and Replacement Vehicles for Year 2 & 3*

In Year 2 and 3 of the program, the contractor shall update the ATC performance model developed in task 3.2.4 to incorporate updated fleet allocation and replacement vehicle performance data as identified in the updated ERA Technology Portfolio generated under NRA Contract No. NNL12AA12C.

10. *Update Safety Scenario Studies for Year 2 & 3*

In Year 2 and 3 of the program, the contractor shall update the safety scenario study based on the refinements made in tasks 3.2.6 through 3.2.9.

**3. Task 3: Strategic Planning and Prioritization Calculator**

The contractor shall modify the Technology Prioritization Calculator (TPC) to incorporate updates to vehicle performance and fleet level impacts due to changes in scenarios and technology portfolios made in section 3.1 and 3.2 (Deliverable 4.7).

1. *Update Vehicle Surrogate Models*

The contractor shall update the vehicle performance surrogate models annually to incorporate updates to current vehicle and to surrogates for additional vehicle configurations identified in section 3.1 and 3.2.

2. *Identify Fleet Metrics for TPC*

The contractor shall, in consultation with the NASA COTR, determine the fleet metrics to be visualized in the TPC, and the type of visualization for these metrics.

3. *Create Fleet Surrogate Models*

The contractor shall define the ranges on the k-factors within GREAT and IDEA that will be used to assess individual technologies in order to generate surrogate models for each of the fleet level metrics defined in task 3.3.2. Based on the k-factor ranges, the contractor shall construct statistics-based “Design of Experiments” (DOE) suitable for the vehicle concepts identified in Task 3.1.4 and generate the results utilizing the GREAT and IDEA fleet tools. Design of experiments (DOE) is a systematic, rigorous approach to engineering problem-solving that applies principles and techniques at the data collection stage so as to ensure the generation of valid, defensible, and supportable engineering conclusions. The contractor shall use the results obtained to create surrogate models.

4. *TPC Development for Visualization of Fleet Metrics*

The contractor shall incorporate the fleet surrogates developed in task 3.3.3 into the TPC and develop TPC visuals for enabling comprehension of fleet level metrics and analysis.

5. *Refine Fleet Metrics for TPC for Year 2 & 3*

In Year 2 and 3 of the program, the contractor shall refine the fleet metrics identified in task 3.3.1 to be visualized in the TPC, the type of visualization, and identify the fleet tool, either GREAT or IDEA, from which to generate the surrogate models.

6. *Update Fleet Surrogate Models for Year 2 & 3*

In Year 2 and 3 of the program, the contractor shall update the ranges on the k-factors within GREAT and IDEA used to assess individual technologies as identified in the updated ERA Technology Portfolio generated under Contract No. NNL12AA12C. The contractor shall then regenerate surrogate models for each of the fleet level metrics defined in task 3.3.5. Based on the k-factor ranges, the contractor shall construct statistics-based “Design of Experiments” suitable for the vehicle concepts identified in Task 3.1.4 and generate the results utilizing the GREAT and IDEA fleet tools. The contractor shall utilize

the results obtained to create surrogate models for incorporation into the TPC.

7. *Refine TPC Visualization for Year 2 & 3*

In Year 2 and 3 of the program, the contractor shall incorporate the fleet surrogates developed in task 3.3.5 into the TPC to refine TPC visuals for enabling comprehension of fleet level metrics and analysis.

## **2. Fleet Level Modeling**

### **1. Background**

Aviation CO<sub>2</sub> emissions are expected to grow significantly in the future. Additionally, it is desirable to not increase or even decrease other emissions as well as the noise exposure of people to aviation noise. This growth occurs primarily due to economic growth and the resultant increase in income that enables more people to travel and to travel by air more frequently. As old aircraft age and airlines retire them newer aircraft types become available that are more efficient than were available before. The rate of this fleet turn-over and additional growth filled by new aircraft determines how efficient the future demand can be served. In order to arrive at the amount of future aviation emissions fleet level modeling of how aircraft types enter and exit airline use and how many emissions noise they produce such that it becomes possible to translate vehicle level improvements from technology modeling to aviation's overall potential future reductions in emissions and noise.

### **2. Fleet Level Modeling Tools**

#### **1. GREAT**

The geographic scope of the ERA program is primarily focused on the U.S. although the effects of technology introduction into the fleet are not geographically limited and extend globally. The scope of the fleet assessment is defined accordingly and prescribes use of applicable datasets and forecasts. There are a number of forecasts available from a myriad of regulatory bodies, industry consortia, and aircraft

manufacturers. The primary aviation forecast used for federal airport and aviation related investments in the US is the FAA Aerospace Forecast. This forecast contains high level macroeconomic projections for the entire aviation industry that is then reconciled with growth projections for each airport and facility to produce the FAA Terminal Area Forecast (TAF) [FAA 2012b, 2013, 2014, 2015]. We utilize forecast figures for itinerant air carrier and air taxi operations as a projection for commercial aviation operations. Data was directly queried from the most recent version of the TAF available at the time this study was conducted, namely the FY 2010-2030 forecast period. We note that the TAF for FY 2010-2030 “initially used the national forecasts of aviation activity contained in FAA Aerospace Forecasts, Fiscal years 2010-2030.” [FAA 2013]. Subsequent annual revisions of the TAF, used in this study covered Fiscal Years to 2040. Accordingly, the data contained in the TAF shown in Fig. 1 are consistent with the FAA Aerospace Forecasts for FY 2011-2031.

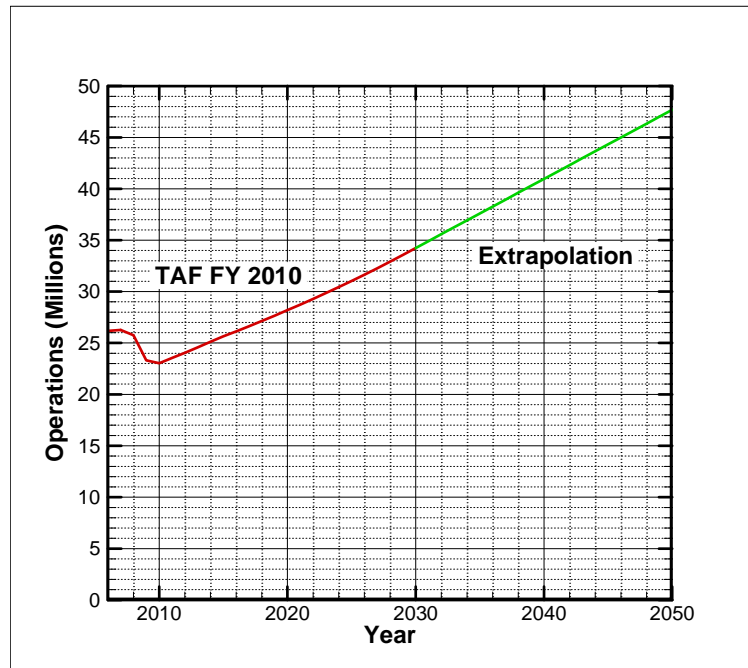


Figure 1: Forecast of U.S. Commercial Aviation Operations [FAA 2013]

Because ERA concept vehicles or “technology collectors” are assumed to enter into service in 2025 the relevant time scope must extend well beyond 2025 to capture ERA concept vehicle introductions



resulting from retirement and replacement rates, as well as the ensuing fleet-level performance improvements. ERA concept vehicles can be reasonably expected to have a very limited impact between 2025 and 2030 due to the limited number of aircraft that would be introduced relative to the rest of the fleet for that period. Conversely, the impact is expected to be much more significant over another 20 year period, where the expectation is that most of the existing fleet would be replaced by ERA concept vehicles or potentially more advanced alternatives. A timeframe of interest through the year 2050 was selected accordingly, consistent with projection timeframes adopted by ICAO for the establishment of CO<sub>2</sub> goals. Forecast values for the 2030-2050 period are estimated as a linear extrapolation of the forecast as noted in Fig. 1.

Projections for the number of operations provided by the TAF are not associated with segments between airports nor does it assign specific aircraft. These origin-destination and aircraft assignments are required as the basic operational input for any environmental assessment. To this end we utilize an operations data set corresponding to worldwide operations in 2006, specifying unique entries of origin, destination, aircraft type, and number of segment operations. This data set was compiled from numerous harmonized data sources including aircraft segment assignments as reported by airlines on DOT Form 41 Schedule T-100, operations databases such as the Enhanced Traffic Management System (ETMS), and radar track data used to estimate flown distance for fuel burn estimates. The set was processed through data filters so as to preserve only U.S. domestic operations between TAF airports as well as international operations with TAF airports as an origin or a destination.

The set of operations for the 2006 baseline year provides the required characterization of aircraft assignments and relative traffic volume to origin-destination segments. However, we note that it does not exactly match TAF figures, and moreover is not operations-balanced (arrivals vs. departures) across all origin-destination pairs. Accordingly, we implement the Fratar algorithm to generate segment operation count estimates (i.e. number of operations for each origin-destination) such that the total number of arrivals and departures at each airport matches the forecasted (or historical) total number of operations stated in the

TAF. For the implementation of the Fratar algorithm we leverage on its relative simplicity and widespread use within the community (see for instance Ref. [Long 1999]). We initialize the algorithm with the operation counts corresponding to the reference year (2006) operations set, inherently specifying the 2006 route structure for the set of airports, and providing a ‘good initial guess’ for the algorithm. In principle the Fratar algorithm is set to match the total number of operations in each airport, so that

$$\sum_j O_{ij} - O_{i,20XX}^{TAF} = 0 \quad (1)$$

Where  $O_{ij}$  is the number operations between origin airport  $i$ , and destination airport  $j$ , and the superscript  $TAF$  and subscript  $20XX$  indicate that the number of operations  $O_i$  for airport  $i$  is that prescribed by the TAF forecast for the forecast year  $20XX$ . Consistent with published literature we found that a perfect value match or a very tight tolerance for the convergence criteria often resulted in a significantly greater (and sometimes prohibitive) number of iterations. Thus, we implement a relaxed value matching convergence criteria as follows:

$$\sum_i^{TAF} \left| \sum_j O_{ij} - O_{i,20XX}^{TAF} \right| < 80,000 \quad (2)$$

The absolute value of the difference between the Fratar estimate and the target value of the TAF is calculated for each airport and summed for the entire set. Convergence is reached for total deltas less than 80,000 operations, which corresponds to less than 0.5% of operations for the baseline year (2006).

In order to allow for variations from the TAF a system-wide scaling factor  $f$  was introduced. Although it is possible to adjust activity levels with greater detail, a general scale factor is deemed sufficient absent more detailed scenario information. The scale factor is applied uniformly to airport activity levels as follows:

$$O_{S,i} = O_{R,i} \prod_{j=y_{start}}^{y_{end}} (1 + f_j)$$

(3)

Where,

$O_{R,i}$  is the reference number of operations at airport  $i$

$O_{S,i}$  is the number of operations at airport  $i$  for scenario  $s$

$f_j$  is scale factor in year  $j$

$y_{start}$  and  $y_{end}$  are the start and end years of the forecasting period

As a result of applying this scale factor the activity levels in the TAF can be artificially scaled up or down by an annual percentage either for the entire forecasting period or fractions thereof.

1. *Fleet Composition Evolution – Retirements and Replacements*

The implementation of the Fratar algorithm described above yields balanced operations counts for a prescribed out year in accordance with TAF figures. The assignment of aircraft types to origin-destination segments in the 2006 reference set is preserved in this operation, and must therefore be adjusted to reflect the evolution of the fleet composition. Fleet evolution is formulated by means of two primary components: retirements and replacements. Retirements model the removal of aircraft from the operating fleet regardless of reason, whereas replacements capture the introduction of new aircraft. Detailed aircraft inventories have been previously used in conjunction with utilization models to exhaustively track fleet composition, project it into the future, and model segment assignments. We argue that such an approach provides moderate accuracy and fidelity improvements for fleet-level studies, and does so at considerable computational resource, data management, and setup effort burden. We adopt a more favorable approach consistent with common practice where retirements and replacements are modeled directly on aircraft type assignments while requiring minimal fleet inventory data.

The algorithm for retirement calculations is initialized with the fleet age for each aircraft type starting on the reference year (2006). For this study the fleet age was characterized with non-parametric age distributions for each aircraft type obtained from a variety of publicly available sources. The mean value may be used in lieu of the entire

distribution as a simpler and less accurate alternative. The age distribution for each aircraft type is then evolved for each out year relative to the 2006 reference, and subsequently normalized to indicate percentage values rather than number of units for that aircraft type.

We then apply empirically derived survival curves, also referred to as retirement curves, which prescribe the percentage of aircraft that remain in operation as a function of age. Accordingly a percentage of aircraft retired as a function of age can be determined across the entire age distribution for a given aircraft type. The provision of retirement figures in percentage values allows for their direct application on operations counts associated with each aircraft type. In other words, retirements are modeled for each aircraft type as a percentage of operations of the 2006 reference set that it will no longer be assigned to in the out year. This approach assumes that the different age aircraft are used uniformly to serve all segments across the entire system and that there is no aircraft age preference in their assignment to specific segments. We believe this assumption to be reasonable and have not found evidence to the contrary. The retirements algorithm is notionally depicted in the top half of Fig. 2. We highlight the empirical nature of survival curves used in this study, representing only historical trends. No additional analysis has been included to explicitly model retirement decisions by aircraft operators over time. Pfaender, Jimenez, and Mavris [Pfaender 2011] demonstrate one such retirement model based on net value estimation within a system dynamics model. We also note that these retirement curves have a dominant effect on results given that they drive how the fleet is retired at any given time; thus they remain a key assumption in the modeling approach we demonstrate here.

## 2. *Replacements Algorithm*

The replacements algorithm implements aircraft type assignments for operations associated with retirements as well as for operations comprising activity growth for a given out year. We encode replacement logic by means of a replacement matrix that specifies on a yearly basis all aircraft types, the aircraft types that are available in that year to

replace the former, and the percentage distribution for replacement aircraft types. Different replacement matrices can be generated to account for different fleet replacement scenarios as demonstrated in the Results section. When executed, the replacements algorithm assigns aircraft types to the sum of retired and growth operations in accordance to the replacement aircraft types and their proportions. These operations are notionally depicted in the bottom half of Fig. 2.

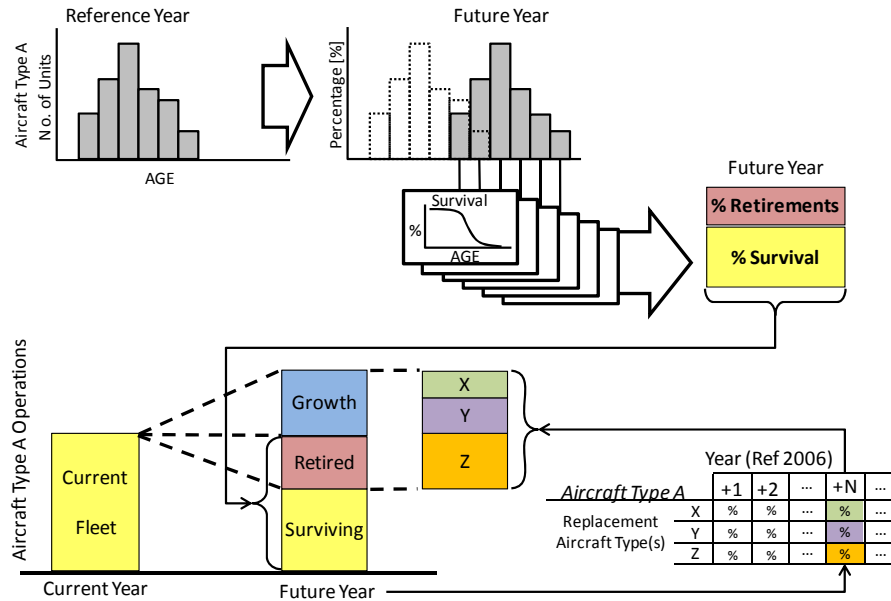


Figure 2: Diagram of retirements algorithm (top), and replacements algorithm (bottom).

It should be evident that essence of the fleet replacement logic lies within the replacement matrix rather than in the algorithm that implements it. Thus, a critical part of the research effort hereby documented consists in the generation of the matrix itself, which we describe now. We formulate replacement logic by means of three fundamental conditions:

Chronological – an aircraft type of later production will replace others of earlier production, and will do so starting on the year that it enters into service.

Mission capabilities – an aircraft type must have a mission range AND payload/seat capacity that are comparable to or exceed those of the aircraft type it replaces

Environmental performance – an aircraft type must have fuel burn that is better than that of the aircraft types it replaces, or a worst that is comparable to that of the aircraft types it replaces

The intent of these conditions, which we now elaborate in detail, is not to provide a detailed characterization of operator decision-making rationale regarding fleet refresh, but rather to abstract and model the predominant trends observable in reality that can be reasonably adopted for our present purposes.

### 3. *Chronological Condition for Replacements*

For the chronological aspect of replacements we first identify aircraft production categories in the interest of structure and traceability. These categories are defined as follows:

Out of Production – refers to aircraft no longer produced by the manufacturer/integrator on the reference year, that are still in service in the operating fleet

In Production – refers to aircraft that are still being produced by the manufacturer/integrator on the reference year, and that are still in service in the operating fleet.

Under Development – refers to aircraft under development or planned for development by industry, and set to enter into service sometime after the reference year. This category includes aircraft not in service in 2006 that have since entered into service such as the Airbus 380, the Boeing 787-8, and the Boeing 747-8. It also includes aircraft for which there were no development plans in 2006 but for which there are currently, including the Airbus 320 NEO family and the competing Boeing 737 MAX 7/8/9 family.

ERA Concept Vehicles – refers to aircraft that are not under development by a manufacturer but that represent vehicles with improved performance designs by virtue of technology implementation. This study only considers ERA concept vehicles for the N+2 timeframe; the N+1 timeframe is ignored in lieu of Under Development aircraft introduced around 2015.

Since replacements take place according to available aircraft for a given future year, replacements resulting from the retirement of an out

of production aircraft type will consist of in production aircraft first, then aircraft under development starting on the corresponding entry into service year, and ERA concept vehicles after that, starting in 2025. Similarly, replacements resulting from the retirement of an in production aircraft type will consist of the same aircraft type first (given that it is still in production), followed by aircraft under development or ERA concept vehicles in later years. Aircraft under development introduced into simulated future operations are also subject to retirement following the narrow-body or wide-body survival curve as appropriate, and are replaced by the same aircraft type first or by ERA concept vehicles in later years. We do not consider production generations beyond the ERA concept vehicles in this study, and thus their retirements remain imperceptible in modeling results since all replacements occur with the same ERA concept vehicle type.

We highlight a crucial feature of this retirement scheme that represents a key improvement over the state of the art, namely that fleet replacements are subject to retirements. Current practices tend to assume retirements exclusively for the reference year fleet. In other words, fleet replacements are not subject to retirements. Under these assumptions some operations conducted by an in production aircraft type in the baseline year, say 2006, will be replaced in a future year, but none of the operations of that aircraft type introduced in a future year, say 2007, will ever be retired. In a similar fashion, operations reflecting the introduction of a new aircraft type (aircraft under development or ERA concept vehicle) are not subject to retirements either. We believe that this approach introduces significant distortions and inaccuracies in the fleet composition that result in an underestimation of system wide improvements, and that the retirement and replacement scheme implemented in this study addresses this shortcoming.

#### *4. Mission Capabilities Condition for Replacements*

With regard to mission capabilities the replacement condition prescribes that an aircraft type must have a mission range and payload/seat capacity that are comparable to or exceed those of the aircraft type it replaces. Such a capability-based approach is intended to

replace the seat-class basis for replacements featured in the state of the art practices. We note that mission range is not explicitly considered, primarily because technology tends to shift aircraft capabilities in many possible ways where no exact one for one capability equivalent is achievable. In contrast, a capability-based approach to replacements considers seat capacity and mission range to determine appropriate replacements while observing chronological and environmental performance conditions.

## **2. IDEA**

The modeling tool utilized for this study is the Integrated Dynamic Environmental Analysis (IDEA) model that is a System Dynamics model of the future of aviation and its environmental consequences. IDEA uses the FAA Aerospace Forecast<sup>1</sup> described above as its baseline forecast and point of departure that can then be influenced by various scenario variables that will deviate from the baseline. These scenario variables affect the way the aviation demand and resulting aircraft use change through the use of feedback loops. IDEA is able to track a number of environmental outcomes such as fuel burn and CO<sub>2</sub> emissions. The metrics of interest here are the energy efficiency, fuel used, and CO<sub>2</sub> emissions of aviation. IDEA has been used in the past to predict the impact of technology portfolios and their introduction dates to the environmental outcomes of aviation and has undergone model improvement of the last few years [Pfaender 2009, 2010, 2010b, 2011]. Specifically, the model focuses on modeling the aircraft fleet turn over, given some technology scenarios where new much improved aircraft become available in certain future years and airlines make rational decisions about potentially upgrading to these new aircraft or continuing to operate existing aircraft. This behavior is subject to production rate constraints, such that airlines cannot instantly upgrade to an extremely attractive new aircraft.

## **3. Aircraft Modeling**

The different vehicles to be introduced into the fleet are represented by a set of coefficients and noise curves to capture their performance in



terms of fuel burn and environmental metrics based on BADA and SAE AIR1845. Each vehicle type and year of introduction into the fleet implies a different set of technologies and affects the values given to those coefficients. However, in order to capture how the technology vehicle performance impacts roll up to the fleet level we have to develop the fuel burn vs distance, LTO NO<sub>x</sub> and surrogates and noise grids that are needed by GREAT and IDEA.

### **1. Fuel Burn**

GREAT and IDEA require a quadratic curve indicating the fuel burn as a function of distance for each vehicle that will be introduced into the fleet. In this case that involves 36 vehicles per scenario with each size class following a slightly different replacement introduction schedule based on typical industrial cycles. The replacement schedule is kept consistent throughout all the scenarios with only the performance characteristics of the vehicles being introduced changing as a reflection of the technologies available.

To generate the GREAT/IDEA input curves a consistent performance evaluation for each vehicle as a function of distance flown is needed. A simplified version of AEDT which implements BADA and SAE 1845 AIR was selected for this since it is intended for fleet level environmental impacts of this type. Each of the 36 vehicles is exercised in this environment for several stage lengths up to its maximum design range. And these calculations are repeated for each of the 10 scenarios: RTC, ITD, ITD UC1, ITD UC2, ERA, ERA UC1, ERA UC2, N+2, N+2 UC1, N+2 UC2. The resulting data for each vehicle type, date of introduction and scenario is then analyzed to generate a quadratic curve regressing the calculated fuel burn vs the distances flown. Note that this results in 360 equations to be used by the fleet level assessments.

### **2. NO<sub>x</sub>**

The cruise NO<sub>x</sub> is calculated in a very similar manner to the fuel burn. Each aircraft is exercised in the AEDT tester for several stage lengths generating the data necessary for a quadratic regression describing NO<sub>x</sub> vs. distance flown. This entire process results in a

further 360 quadratic regression equations of NO<sub>x</sub> vs distance for each aircraft being introduced in each scenario.

The LTO NO<sub>x</sub> calculations are a bit more complicated because they are not only dependent on the distance flown, but also on the environmental conditions of the departure and arrival airports. As such, for each aircraft to be introduced two equations are needed as a function of: distance, elevation, temperature, and relative humidity, one for Take-Off NO<sub>x</sub> and one for Landing NO<sub>x</sub>. These drivers are not mutually independent when it comes to their impact on LTO NO<sub>x</sub> so quadratic and cross terms are also needed. A design of experiments was generated for each vehicle class in order to ensure the most efficient coverage of the parameters with a minimum number of runs. Each vehicle is then exercised in AEDT with each of the environmental conditions dictated by the DoE, first for the arrival airport and then for the departure airport, and all the data is collected. This involved in the order of 15-20 runs of AEDT for each vehicle for each scenario for each arrival and departure NO<sub>x</sub>. The data collected for each of the 36 vehicles introduced within each scenario is then regressed to obtain two 15 term equations relating that vehicles Landing and Take Off NO<sub>x</sub> emissions to the flight distance and environmental conditions. And the process is repeated for all 10 scenarios. This resulted in the generation of a further 720 multi-term equations.

### **3. Noise**

The same environment is used to generate single even noise levels at a fine grid resolution around a single straight virtual runway. This is repeated for different mission lengths. These grid are the used in the method described by [Bernardo 2015].

### **4. Fleet Evaluation Scenarios**

There are many factors which went into the creation of various scenarios to analyze future fleet performance. These factors include the forecasted rate of growth of fleet operations, when new aircraft enter and old aircraft exit the fleet, when upgrades for aircraft become available, when new engine/airframe configurations become available, what new

technologies are to be introduced and when do those technologies become available. There were 5 technology scenarios evaluated for fleet performance. They included Business-as-Usual (BAU), Reference Technology Collector (RTC), Integrated Technology Demonstrator (ITD), Environmentally Responsible Aviation phase 1 and 2 (ERA) and N+2. Each of these technology scenarios specifies the technologies that are available for introduction into the fleet. For the first two scenarios, BAU and RTC, there was only 1 aircraft configuration scenario. For the ITD, ERA and N+2 technology scenarios, there were 3 aircraft configuration scenarios. Each of these scenarios, and the resulting fleet replacement schedule, is described in the following sections.

The vehicles generated for each scenario were created in the Environmental Design Space (EDS) [Kirby 2008, Schutte 2012] as part of the work documented in “Application of Deterministic and Probabilistic System Design Methods and Enhancements of Conceptual Design Tools for ERA Project Final Report”. EDS generated the XML files for the technology infused aircraft to enable their placement in the fleet for analysis by AEDT. A total of 339 aircraft were generated to cover all of the different vehicle classes, technology scenarios and aircraft configurations

### **1. Technology Scenarios**

There were 5 technology scenarios evaluated in this report: BAU, RTC, ITD, ERA and N+2. Each scenario builds off of the technologies from the previous scenario and will keep the technologies from the previous set unless a better technology replaces it. Besides the technologies, it was necessary to establish an implementation schedule for additional parameters. For the engine, an efficiency delta was applied to all of the turbo machinery components for improvements in component efficiencies over the next 20 years. Also, for geared fan engines, a FPR schedule was created to decrease the FPR to its 2025 value gradually. The fan pressure ratio starts at 1.5 for the large engines (STA, LTA and VLA class) and continually decreases to 1.35 by 2025. The large engine FPR starts out higher than the small engine FPR due to diameter constraints. The small engine FPR starts at 1.45 and reduces to

1.35 by 2025. Beyond 2025 there was no change to the geared fan cycle. The engine parameter schedules can be seen in Figure 3.

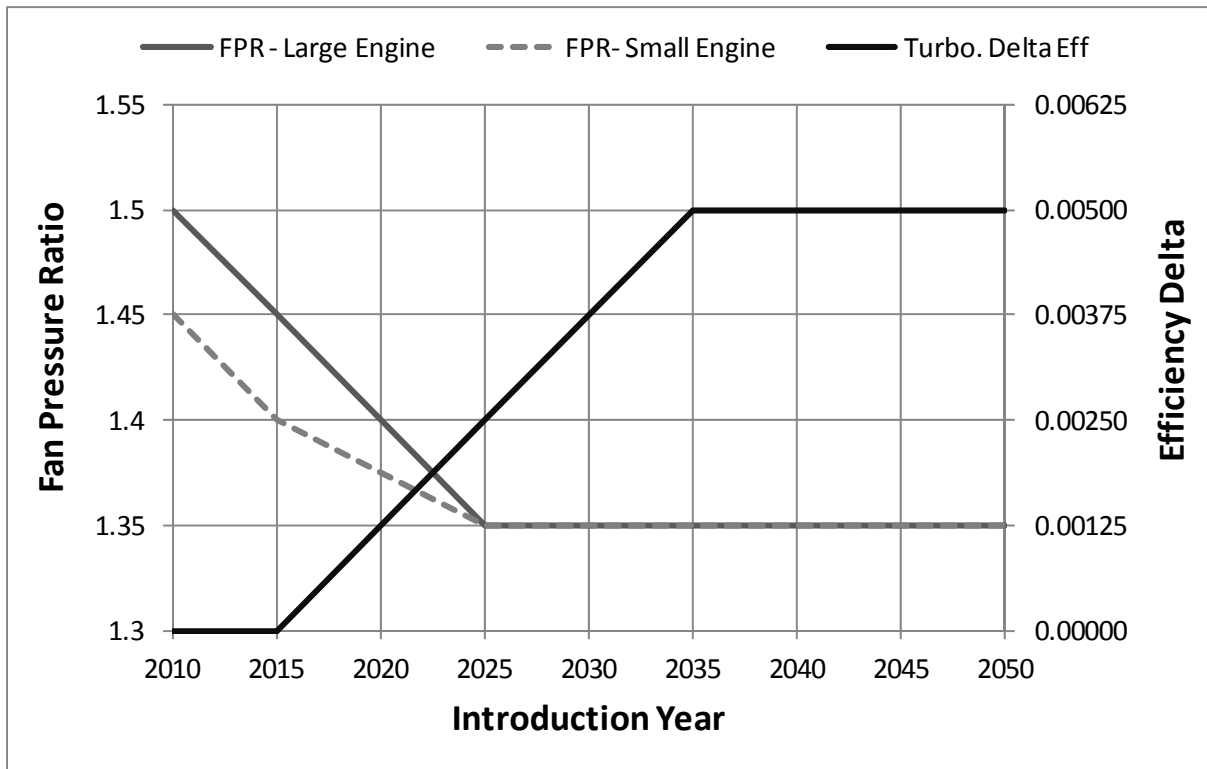


Figure 3. Engine FPR and Efficiency Schedule

Schedules were also included for some of the airframe parameters, specifically, wing parameters. The first was the aspect ratio of the wing (T&W configurations only). The aspect ratio for the wing starts at 10 for all tube and wing aircraft in 2015 and increases continually to 11.625 in 2040. As the aspect ratio increases, a delta impact from gustload on the structural weight of the wing also was increased out to 2040. Both of these trends can be scene in Figure 4.

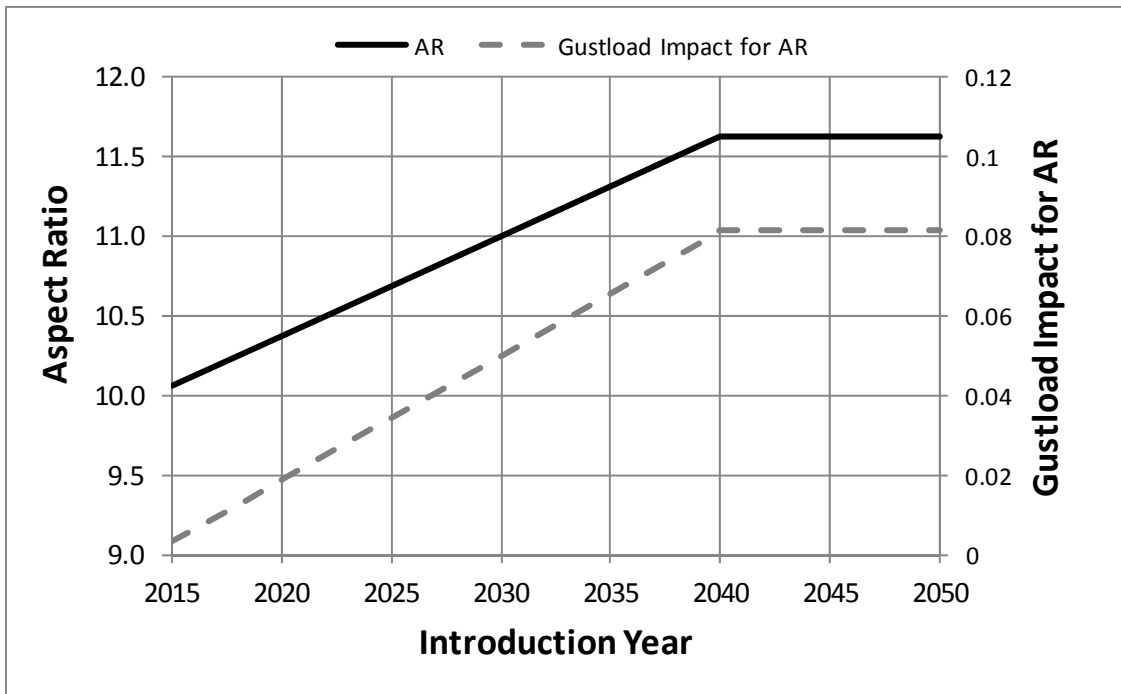


Figure 4. Wing AR and Gust load Schedule

1. *Business-as Usual*

The basic worst-case scenario considered is the BAU scenario. This scenario represents a very conservative worst case, where no new aircraft types or improved technologies enter the fleet. Essentially, development of new aircraft types stops and manufacturers continue to produce their best existing aircraft in each class. This means that after all out-of-production aircraft have been retired from the fleet, the entire fleet behaves as a homogeneous mix of current in-production types. As such, after a transition period of no more than about 25-30 years, the fleet efficiency no longer improves.

2. *Reference Technology Collector*

The next scenario considered is the RTC. This scenario represents aircraft that have been updated to today's current technology level. In essence, no new technology development takes place in this scenario, but new aircraft types are created in each class with the currently available technology. This results in a single new aircraft in each class being available immediately for replacement, but, that aircraft does not change for the rest of the simulation. Therefore, there are no more gains

in fleet efficiency once all aircraft originally in the fleet at the start of the evaluation are replaced.

3. *Integrated Technology Demonstrator*

The third scenario is the ITD. This scenario includes aircraft with technologies from NASA ERA's phase II technologies. These technologies are added to the RTC technologies from the previous scenario.

4. *Environmentally Responsible Aviation Phase 1&2*

The fourth scenario contains the ITD technologies plus technologies from Phase 1 of the ERA project.

5. *N+2*

The fifth scenario is the N+2 technologies. These were technologies that NASA ERA was not maturing but which were found to be potentially available in the N+2 timeframe. As such, they represent technologies being matured by other government agencies and by industry. While the actual technologies being developed outside the ERA project might differ materially from those selected for the N+2 portfolio, their impact on the different metrics is most likely captured. For example, there may be several potential technologies that reduce flap edge noise. The selection of one over the other would be left to the detailed design. For the fleet assessment study, they can be treated equally since they would be modeled to have the same impact on the flap edge noise source that would be used to generate the NPD curves for use by AEDT. Thus, it is more important for the fleet assessment to capture the impact than the specific technology. An example of the expected progression in performance as one advances from BAU to N+2 technology portfolios is shown in Figure 5.

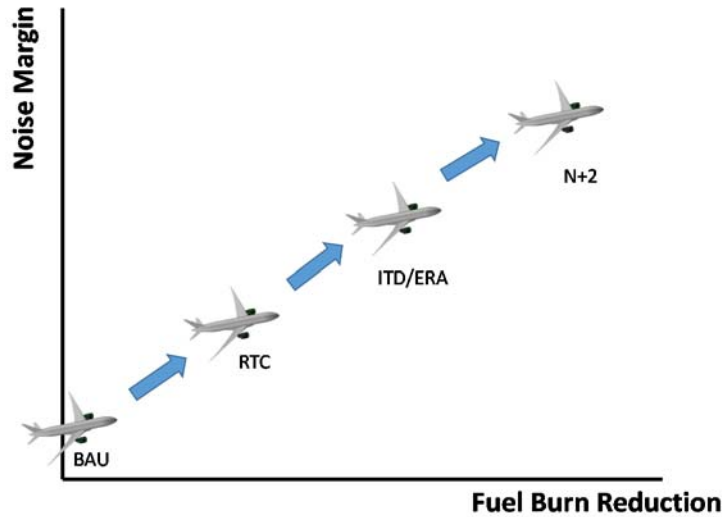


Figure 5. Technology Portfolio Impacts

6. Technology Introduction Dates

Table 1 lists the technologies used for the study. Details of the modeling and impacts of the technology can be found in the report “Environmentally Responsible Aviation Systems Analysis Report: Technology Portfolio and Advanced Configurations: Executive Summary”. Table 1 lists which of the portfolios each technology belongs to and the date when the technology is first available to be incorporated into new aircraft entering the fleet. The technologies are not retrofit into existing aircraft in the fleet.

Table 1. Technology Portfolios and Insertions Dates

Technology	Portfolio				Date
	RTC	ITD	ERA	N2	
Advanced TBC Coatings - HPT Blade	RTC	ITD	ERA	N2	2015
Advanced TBC Coatings - HPT Vane	RTC	ITD			2015
Advanced TBC Coatings - LPT Blade	RTC	ITD	ERA	N2	2015
Advanced TBC Coatings - LPT Vane	RTC	ITD			2015
Aft Cowl Liners	RTC	ITD	ERA	N2	2015
Blisk	RTC	ITD	ERA	N2	2015
Combustor Noise Plug Liner	RTC	ITD	ERA	N2	2015
Composite Technologies (2010 Baseline)	RTC	ITD	ERA	N2	2015
Excrescence Reduction	RTC	ITD	ERA	N2	2015
Fixed Geometry Core Chevrons	RTC	ITD	ERA	N2	2015
PMC Fan Blade with Metal Leading Edge	RTC	ITD	ERA	N2	2015
Polymer Matrix Composites (PMC) - Bypass Duct	RTC	ITD	ERA	N2	2015
Polymer Matrix Composites (PMC) - Fan Case	RTC	ITD	ERA	N2	2015
Polymer Matrix Composites (PMC) - Fan Stator	RTC	ITD	ERA	N2	2015

Polymer Matrix Composites (PMC) - Nacelles	RTC	ITD	ERA	N2	2015
Ti-Al - LPT Aft Blades	RTC	ITD	ERA	N2	2015
Ti-Al - LPT Stator	RTC	ITD	ERA		2015
Variable Area Nozzle - GTF	RTC	ITD	ERA	N2	2015
Zero Splice Inlet	RTC	ITD	ERA	N2	2015
Advanced ITD GF Cycle		ITD	ERA	N2	2020
Advanced Powder Metallurgy Disk - HPC Last Stage Disc		ITD	ERA	N2	2020
Advanced Powder Metallurgy Disk - HPT Disc		ITD	ERA	N2	2020
Advanced Powder Metallurgy Disk - LPT First Stage Disc		ITD	ERA	N2	2020
Advanced Turbine Superalloys - LPT Last Stage Disc		ITD	ERA	N2	2020
AFC Tail		ITD	ERA	N2	2020
CMC Exhaust Core Nozzle		ITD	ERA	N2	2020
Continuous Moldline Link for Flaps		ITD	ERA	N2	2020
Damage Arresting stitched composites- Fuselage		ITD	ERA	N2	2020
Damage Arresting stitched composites- Wing		ITD	ERA	N2	2020
Highly Loaded Compressor - GTF		ITD	ERA	N2	2020
ITD Advanced TBC Coatings - HPT Blade		ITD	ERA		2020
ITD Advanced TBC Coatings - HPT Vane		ITD			2020
ITD Advanced TBC Coatings - LPT Blade		ITD	ERA		2020
ITD Advanced TBC Coatings - LPT Vane		ITD			2020
Landing Gear Integration - Main		ITD	ERA	N2	2020
Landing Gear Integration - Nose		ITD	ERA	N2	2020
Lightweight CMC Liners			ERA	N2	2020
Low Interference Nacelle		ITD	ERA	N2	2020
Natural Laminar Flow - Nacelle		ITD	ERA	N2	2020
Natural Laminar Flow - Wing		ITD			2020
Over the Rotor Acoustic Treatment		ITD	ERA	N2	2020
RQL Combustor (TALON X)		ITD	ERA	N2	2020
Soft Vane		ITD	ERA		2020
Ti-Al - LPT Forward Blades		ITD	ERA		2020
Adaptive Compliant Trailing Edge		ITD	ERA	N2	2025
GTF Cycle	RTC				2015
Gust Load Alleviation	RTC				2015
Compound Rotor Sweep for UHB Fan (GTF)				N2	2018
Short Nacelle Lip Liner				N2	2018
Riblets - Fuselage				N2	2019
Riblets - Wing				N2	2019
Active Turbine Clearance Control				N2	2020
Active Turbine Flow Control - GTF				N2	2022
Advanced Turbine Superalloys - HPT Blades				N2	2022
Advanced Turbine Superalloys - LPT Blade				N2	2022
CMC HPT Vane + Hi Temp Erosion Coating			ERA	N2	2022
CMC LPT Vane + Hi Temp Erosion Coating			ERA	N2	2022
Cooled Cooling - Turbine				N2	2022
Out-of-Autoclave Composite Fabrication - Fuselage				N2	2022
Out-of-Autoclave Composite Fabrication - Wing				N2	2022
Thrust Reversers - Nacelles				N2	2022
Active Compressor Clearance Control				N2	2024
DRE for HLFC - Wing			ERA	N2	2025
N+2 Advanced TBC Coatings - HPT Blade				N2	2025
N+2 Advanced TBC Coatings - LPT Blade				N2	2025



Primary Structure Joining Methodologies - Fuselage				N2	2026
Primary Structure Joining Methodologies - Wing				N2	2026
Active Film Cooling				N2	2027
Highly Loaded HP Turbine				N2	2027
Slat Inner Surface Acoustic Liner				N2	2027
Solid Oxide Fuel Cell Auxiliary Power Unit				N2	2028
Noise Cancelling Stator (GTF)				N2	2032

## 2. Aircraft Configuration Scenarios

Scenario	RJ	SSA	LSA	STA	LTA	VLA
RTC ITD ERA N+2	T&W - GF	T&W - GF	T&W - GF	T&W - GF	T&W - GF	T&W - GF
ITD UC1	T&W - GF	T&W - GF	T&W - GF	HWB - GF	HWB - GF	HWB - GF
ITD UC2 ERA UC2 N+2 UC2	T&W - GF	T&W - GF	OWN - GF	HWB - GF	MFN - GF	HWB - GF
ERA UC1 N+2 UC1	T&W - GF	T&W - OR	T&W - OR	HWB - GF	HWB - OR	HWB - GF

The table above shows which configurations were selected for the respective technology scenarios. The selection was made in accordance which configuration showed the most benefit for either fuelburn reduction or noise reduction. These scenarios are labeled UC1 or UC2 respectively.

## 3. Fleet Replacement Schedule

	2012	2013	2014	2015	2016	2017	2018	2019	2020	2021	2022	2023	2024	2025	2026	2027	2028	2029	2030	2031	2032	2033	2034	2035	2036	2037	2038	2039	2040	2041	2042	2043	2044	2045	2046	2047	2048	2049	2050		
RJ									◆ (E-2)																																
SSA/LSA		◆ NEO/MAX	◆						○										◆																						
STA	◆ B787							○													◆							○													
LTA		◆ A350	◆						◆ B777X						○							○					◆														
VLA	◆ B747-8							○								○					◆							○													

- ◆ Major Technology Upgrade
- Incremental Technology Upgrade

Figure 6 Fleet Replacement schedule from foundational model

Figure 6 shows the foundational fleet introduction schedule that was used as a starting point in defining the introduction schedule

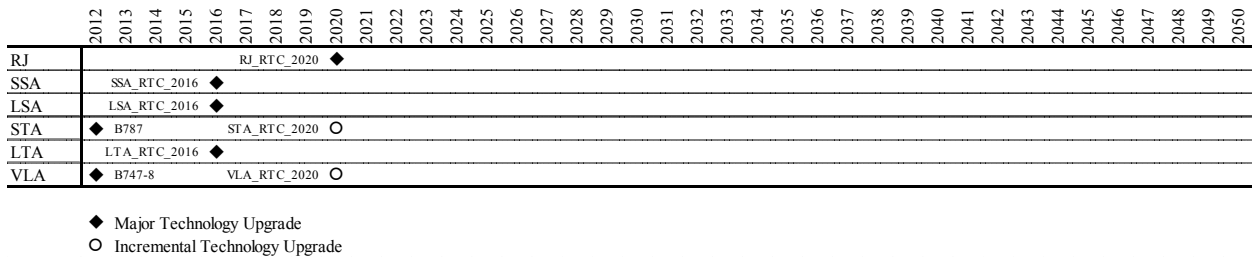


Figure 7 Fleet Replacement schedule foundational model for RTC technologies

Figure 7 shows the final schedule for introductions that was used for the RTC technologies. Since the RTC scenario is supposed to represent the current state of the art that will be introduced across different sizes of aircraft until an even level of technology is achieved, there are no new introduction beyond 2020 due to the expectation that then all sizes across the board have achieved an equal level of technology representative of the current state of the art.

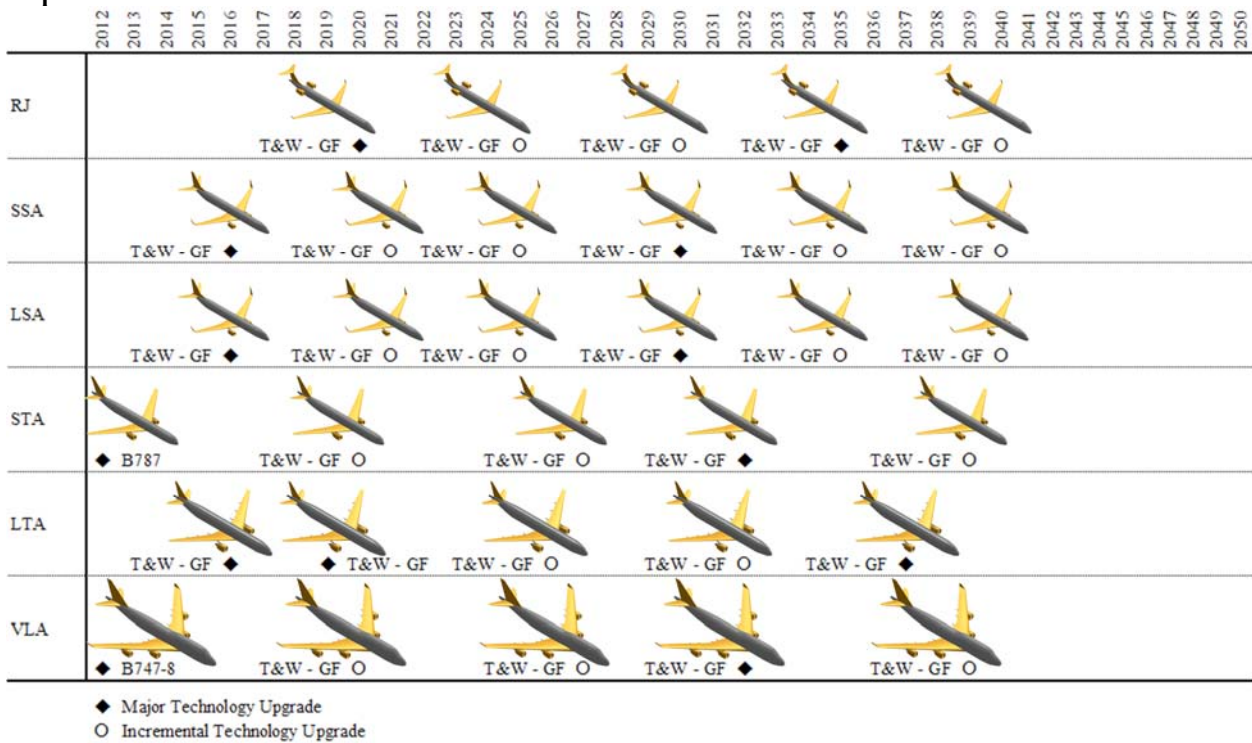


Figure 8. Fleet Replacement Schedule for Scenarios RTC, ITD, ERA, and N+2

Figure 8 shows the replacement schedule that was used for all scenarios of varying technology portfolios with conventional tube and wing aircraft design only.



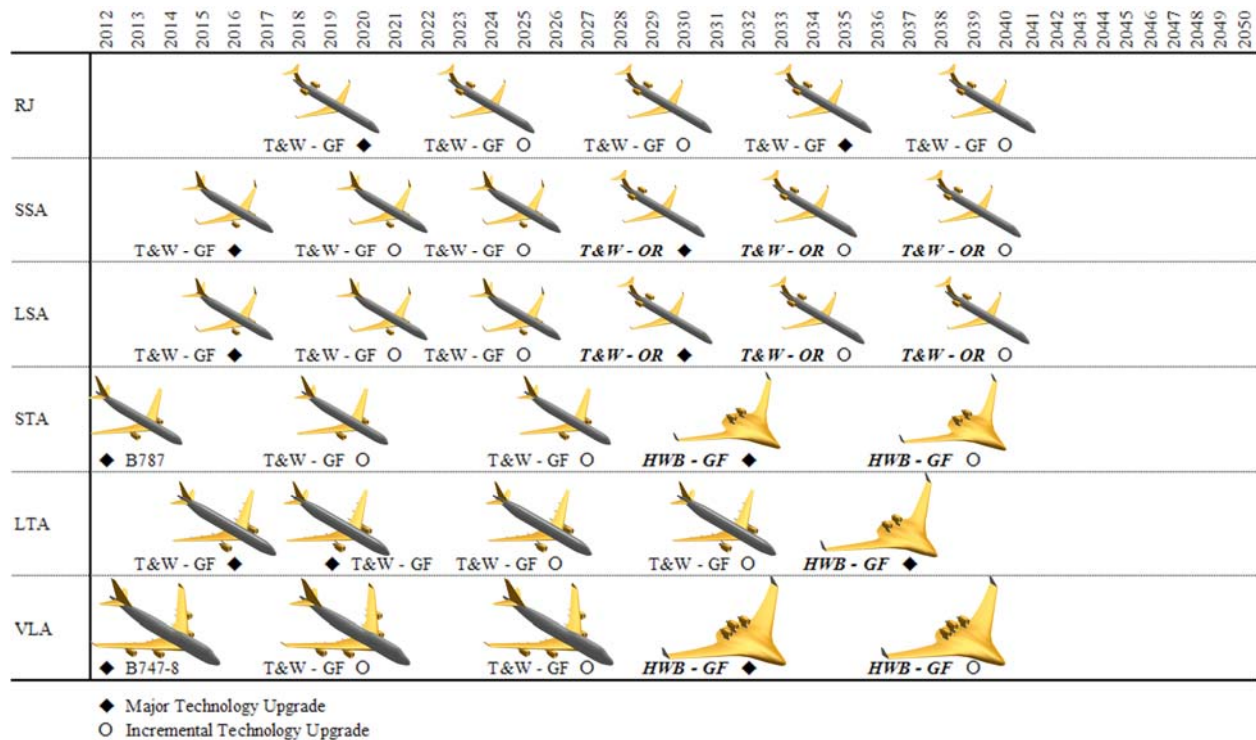


Figure 10. Fleet Replacement Schedule for Scenarios ERA UC1 and N+2 UC1

Figure 10 shows the replacement schedule for the remainder of the replacement schedules focusing on fuelburn performance. They include open rotor engines, which require alternate engine placements, especially on the smaller aircraft size in the form of fuselage mounted concepts.

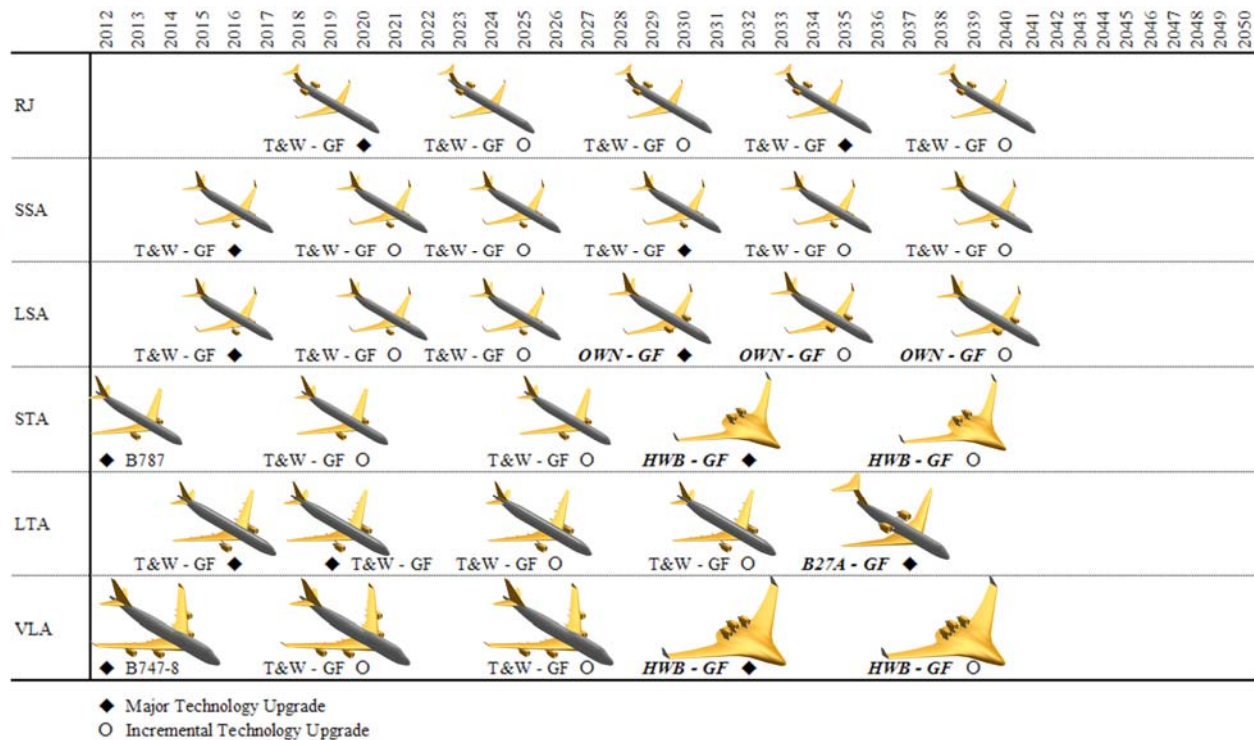


Figure 11. Fleet Replacement Schedule for Scenarios ITD UC2, ERA UC2 and N+2 UC2

Figure 11 shows the replacement schedule for all noise focused unconventional technology scenarios. They tend to favor over the wing engine placement. Therefore, the concepts range from over the wing single aisle concepts to heavily shielded HWB configurations and do not include open rotor engines.

### 5. EDS Fleet Vehicle Performance

The vehicle performance is based on EDS vehicle models created for the accompanying vehicle research effort. Therefore, the following charts, Figure 12 to Figure 27 show an overview of the specific vehicle attributes for all scenarios and how the performance evolves with year of entry into service. This ensures a steady progression of the key performance metrics used in the fleet analysis as well as consistency with the incremental technology assumptions.

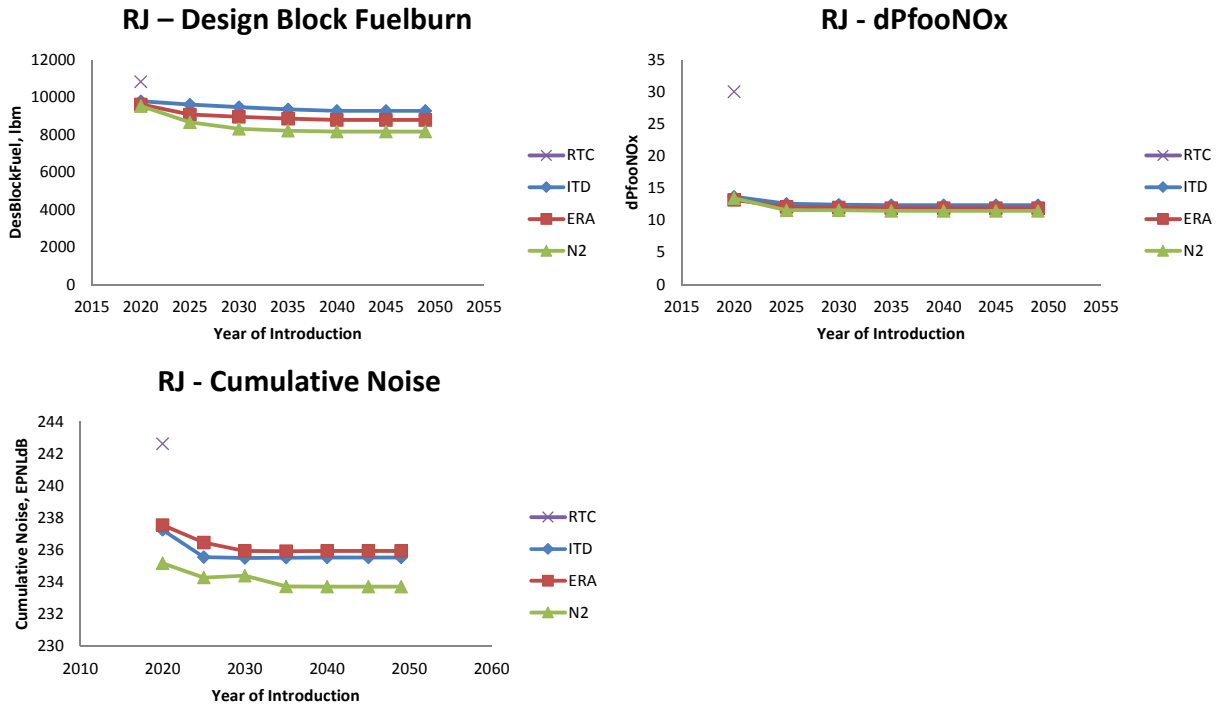


Figure 12. EDS Vehicle Performance for Fleet Scenarios - RJ Class

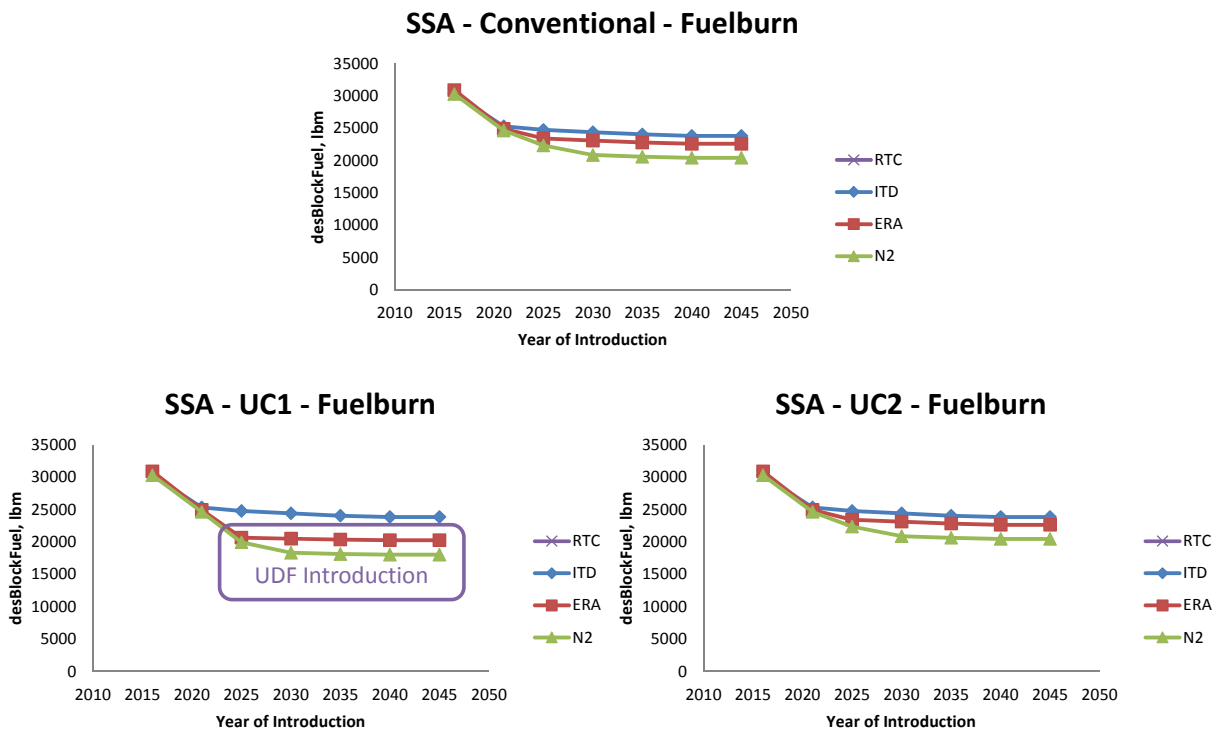
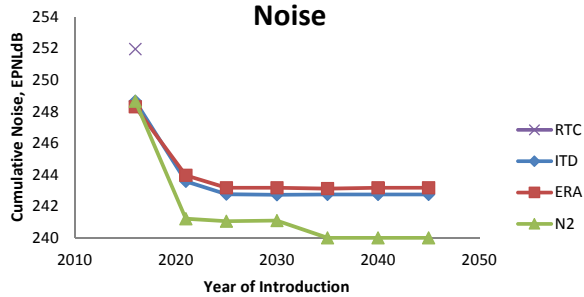
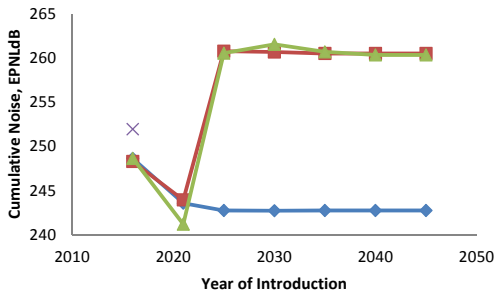


Figure 13. EDS Vehicle Fuel Burn Performance for Fleet Scenarios - SSA Class

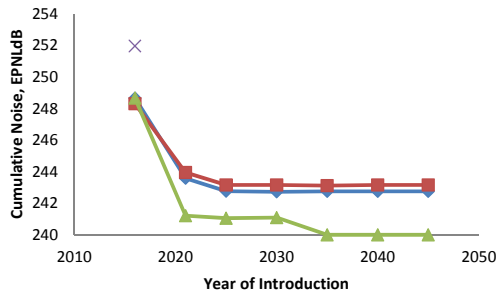
**SSA - Conventional- Cumulative Noise**



**SSA - UC1 - Cumulative Noise**

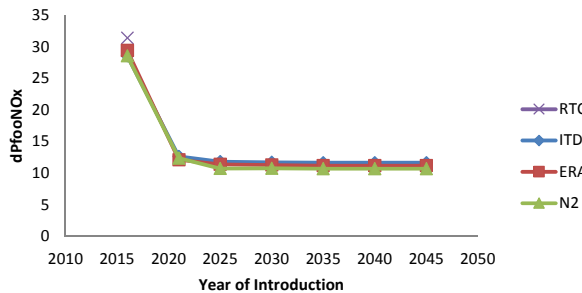


**SSA - UC2 - Cumulative Noise**

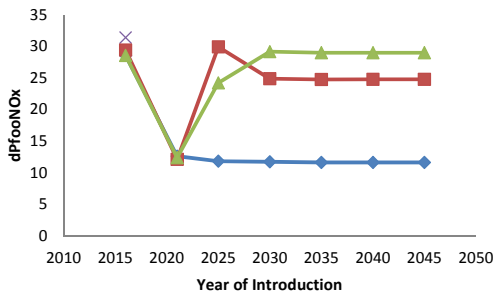


**Figure 14. EDS Vehicle Noise Performance for Fleet Scenarios - SSA Class**

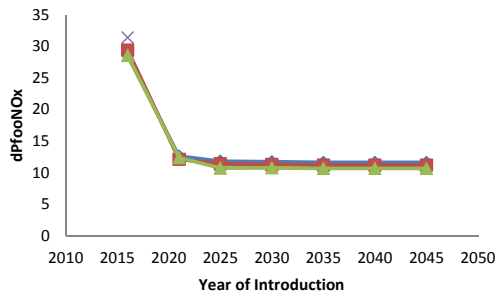
**SSA - Conventional - dPfooNOx**



**SSA - UC1 - dPfooNOx**



**SSA - UC2 - dPfooNOx**



**Figure 15. EDS Vehicle Emissions Performance for Fleet Scenarios - SSA Class**

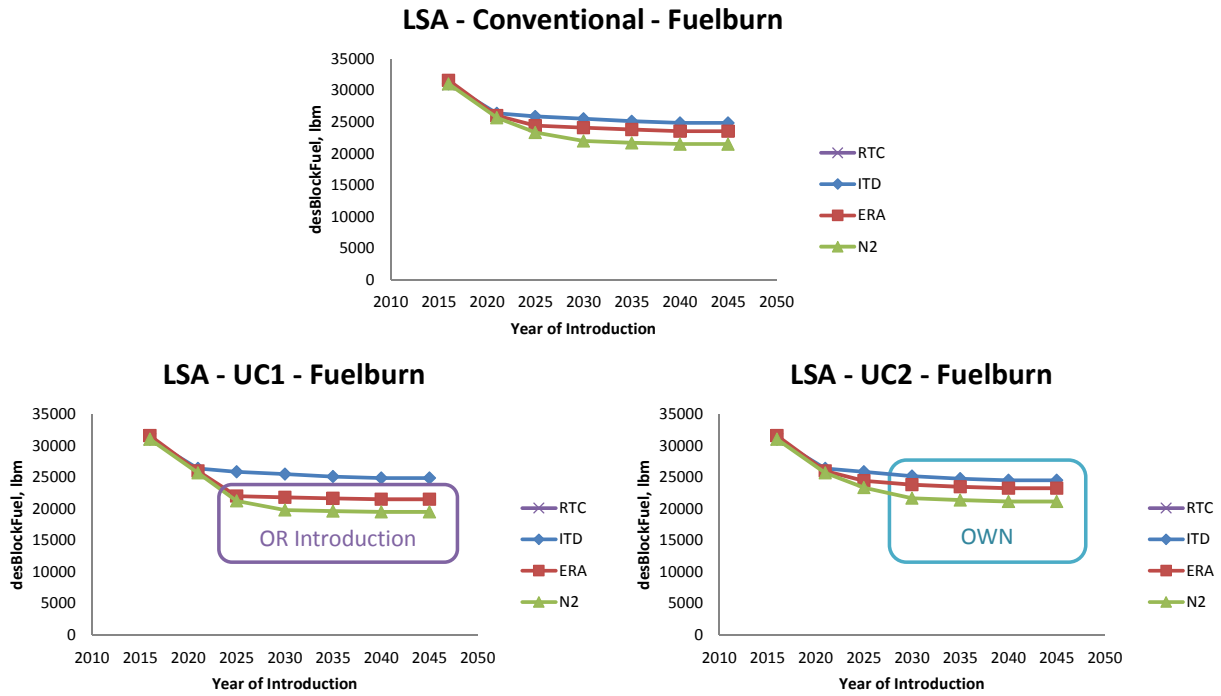


Figure 16. EDS Vehicle Fuel Burn Performance for Fleet Scenarios - LSA Class

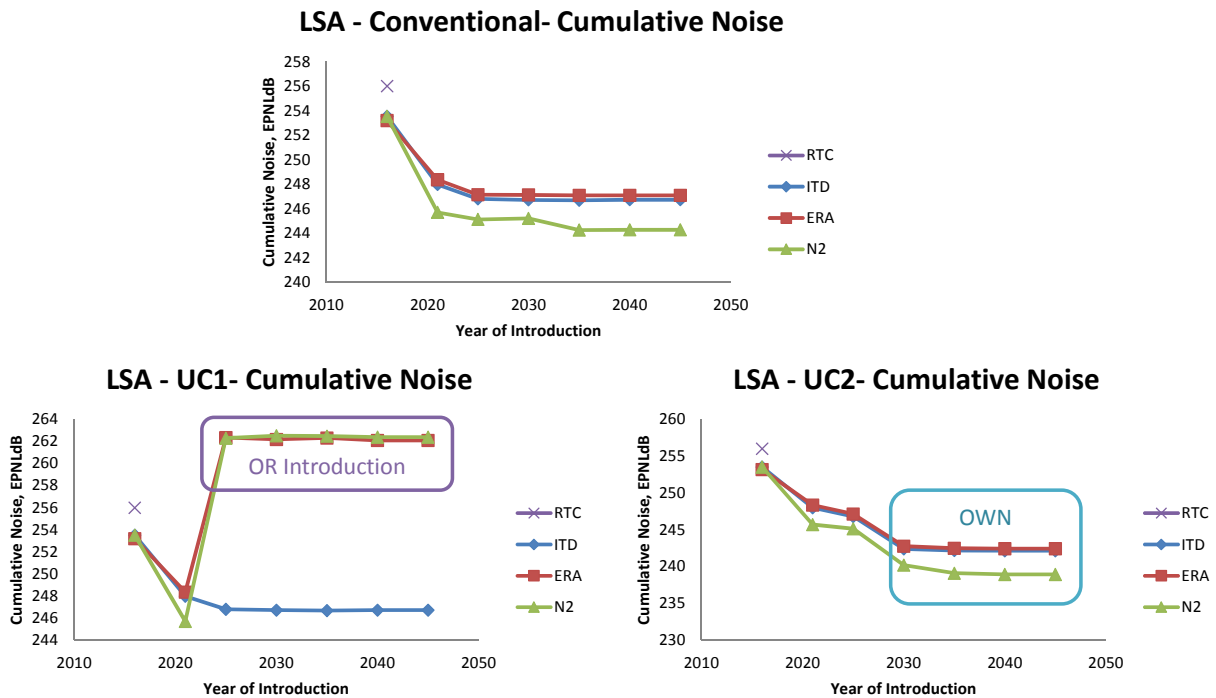
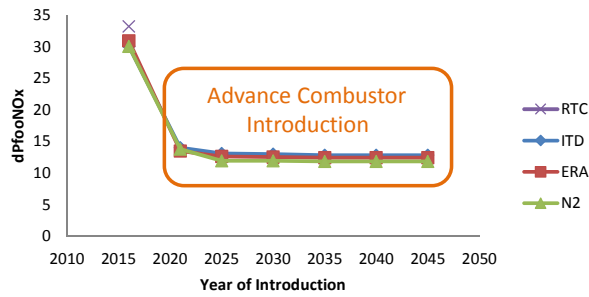


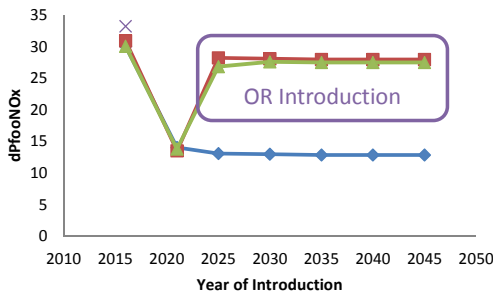
Figure 17. EDS Vehicle Noise Performance for Fleet Scenarios - LSA Class



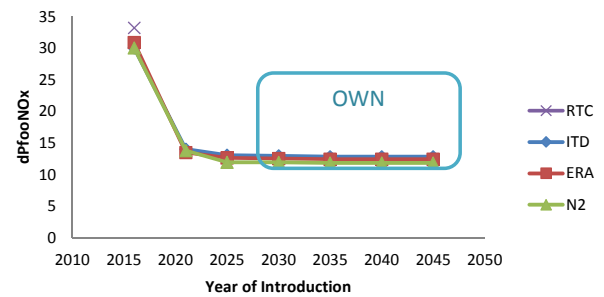
**LSA - Conventional - dPfooNOx**



**LSA - UC1 - dPfooNOx**

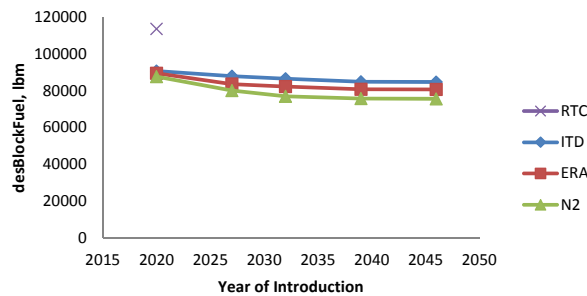


**LSA - UC2 - dPfooNOx**

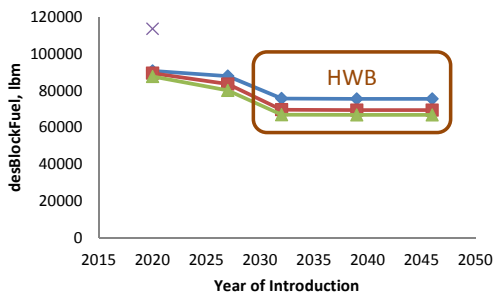


**Figure 18. EDS Vehicle Emissions Performance for Fleet Scenarios - LSA Class**

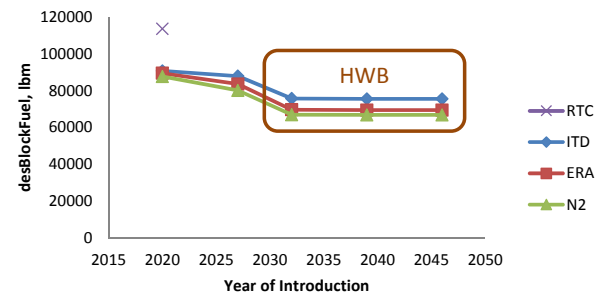
**STA - Conventional - Fuelburn**



**STA - UC1 - Fuelburn**

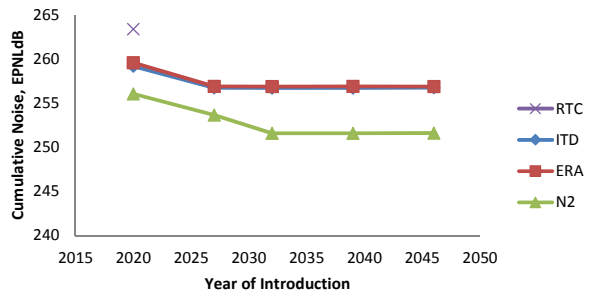


**STA - UC2 - Fuelburn**

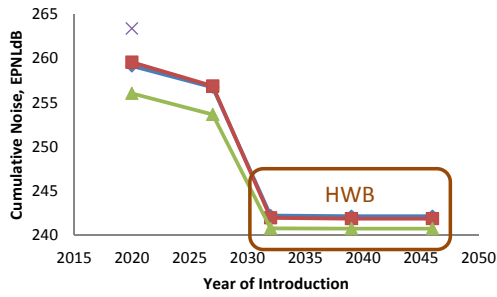


**Figure 19. EDS Vehicle Fuel Burn Performance for Fleet Scenarios - STA Class**

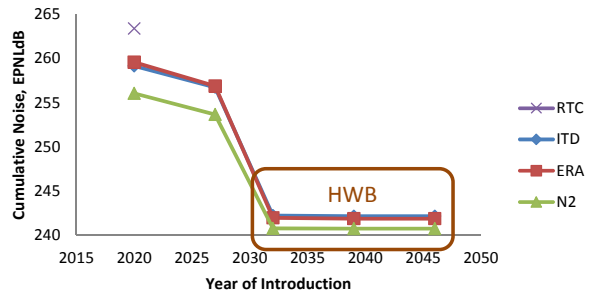
**STA - Conventional- Cumulative Noise**



**STA - UC1 - Cumulative Noise**

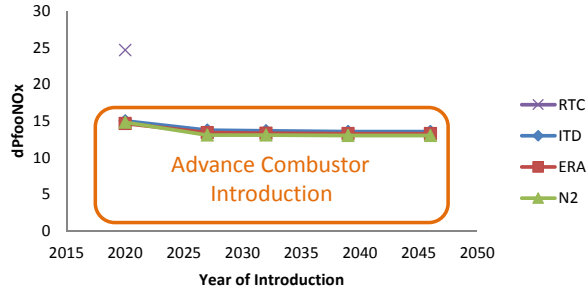


**STA - UC2 - Cumulative Noise**

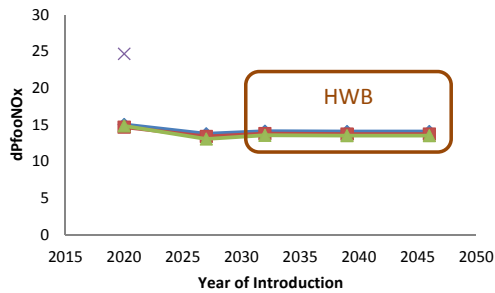


**Figure 20. EDS Vehicle Noise Performance for Fleet Scenarios - STA Class**

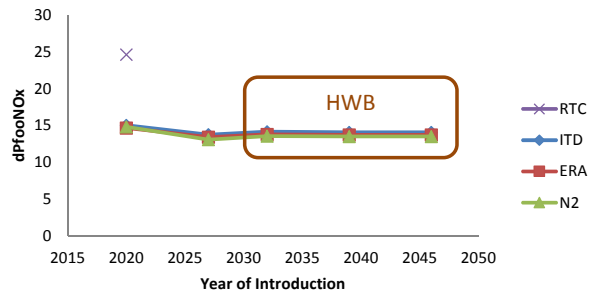
**STA - Conventional - dPfooNOx**



**STA - UC1 - dPfooNOx**

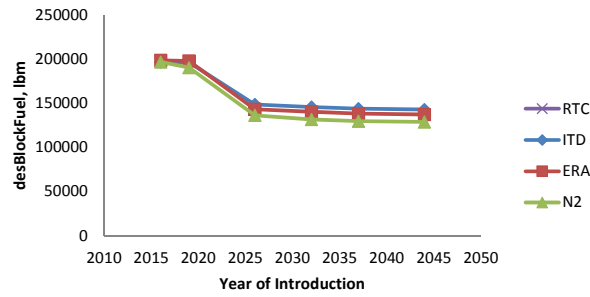


**STA - UC2 - dPfooNOx**

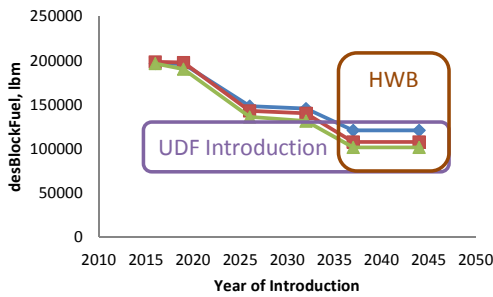


**Figure 21. EDS Vehicle Emissions Performance for Fleet Scenarios - STA Class**

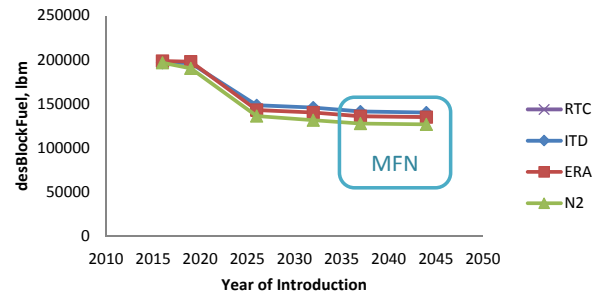
**LTA - Conventional - Fuelburn**



**LTA - UC1 - Fuelburn**

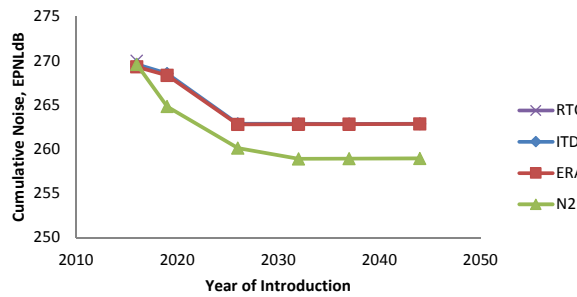


**LTA - UC2 - Fuelburn**

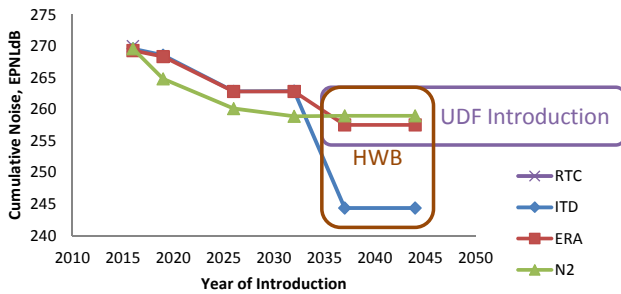


**Figure 22. EDS Vehicle Fuel Burn Performance for Fleet Scenarios - LTA Class**

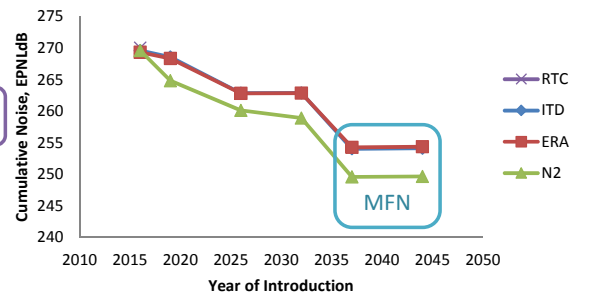
**LTA - Conventional- Cumulative Noise**



**LTA - UC1 - Cumulative Noise**



**LTA - UC2 - Cumulative Noise**



**Figure 23. EDS Vehicle Noise Performance for Fleet Scenarios - LTA Class**

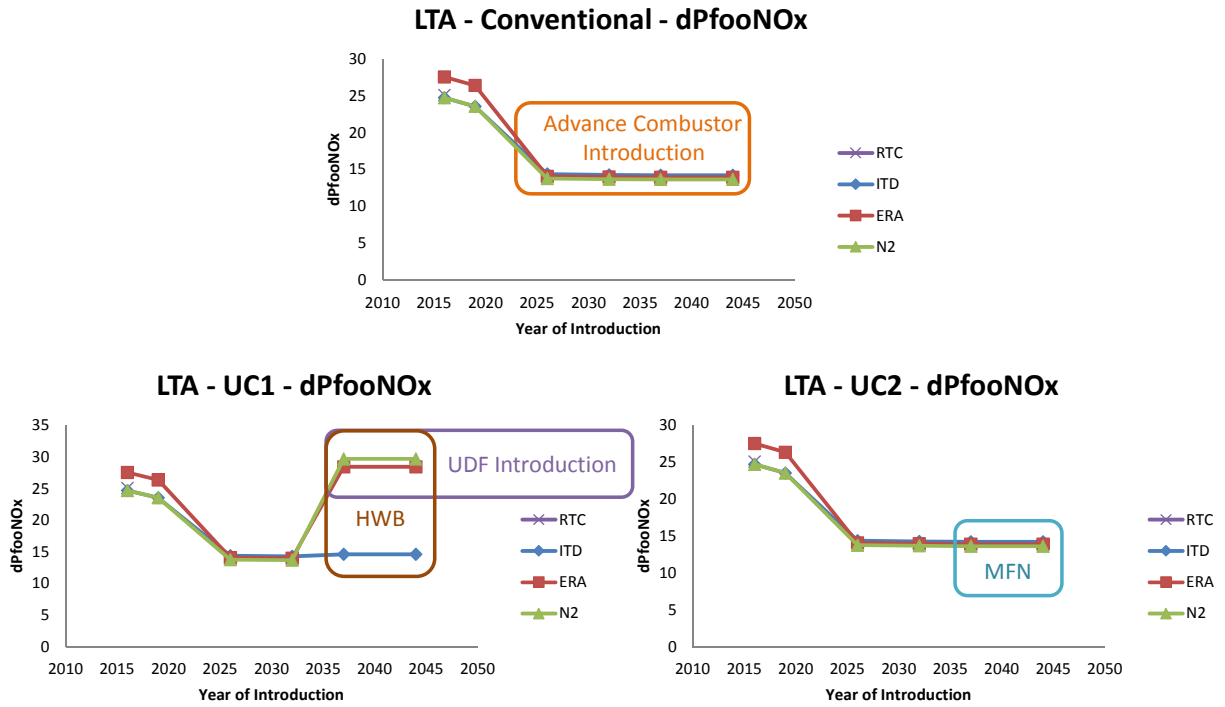


Figure 24. EDS Vehicle Emissions Performance for Fleet Scenarios - LTA Class

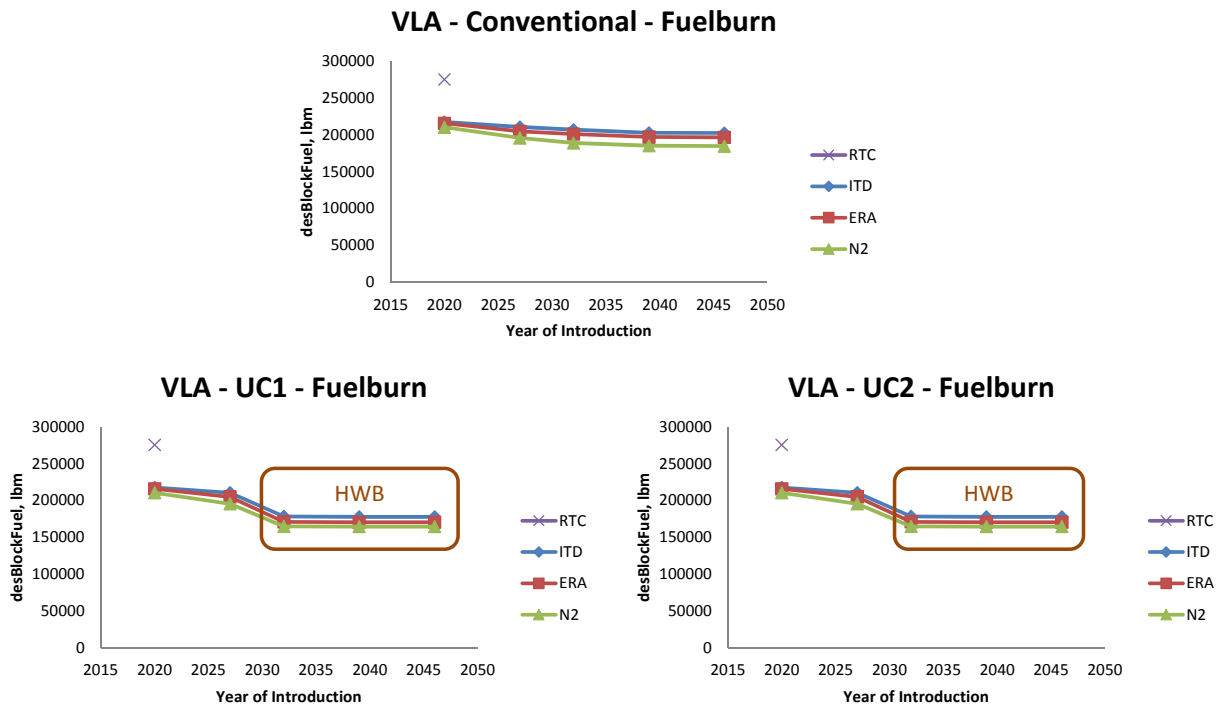
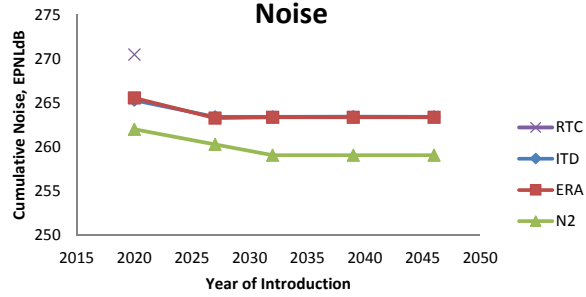
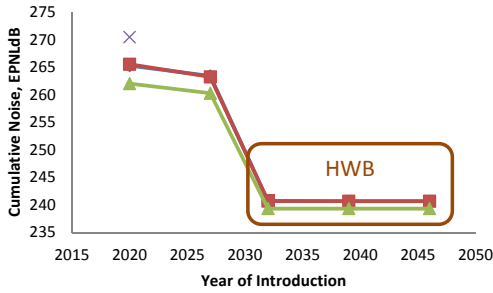


Figure 25. EDS Vehicle Fuel Burn Performance for Fleet Scenarios - VLA Class

### VLA - Conventional- Cumulative Noise



### VLA - UC1 - Cumulative Noise



### VLA - UC2 - Cumulative Noise

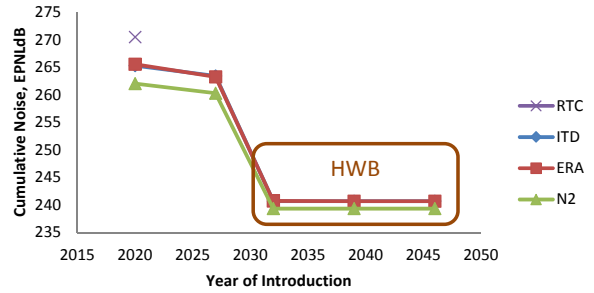
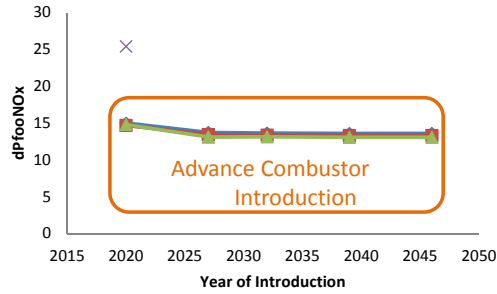
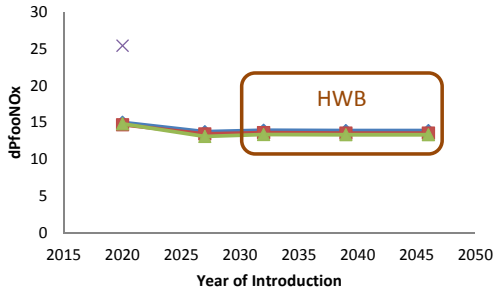


Figure 26. EDS Vehicle Noise Performance for Fleet Scenarios - VLA Class

### VLA - Conventional - dPfooNOx



### VLA - UC1 - dPfooNOx



### VLA - UC2 - dPfooNOx

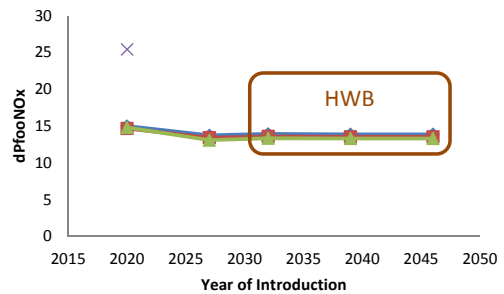


Figure 27. EDS Vehicle Emissions Performance for Fleet Scenarios - VLA Class

## 6. Vehicle Coefficients for Fleet Assessment

Vehicle technology impacts were to be rolled up to the fleet level as part of this work by executing a fleet level environmental impact tool called AEDT. AEDT calculations are based on BADA vehicle definitions for high altitude and SAE Air1845 for calculations below 10,000ft. The generation of the necessary input XML files had been automated as part of the creation of EDS, but the sheer number of vehicles being considered in this case to cover all vehicle classes, year of introduction, and scenario combinations severely tested the robustness of the original algorithms. One of the main issues in properly defining the necessary coefficients for the AEDT input file is that in both BADA and SAE Air1845, the coefficients used often do not have a physical meaning. They are not things like Max Thrust or Overall Pressure Ratio, but rather thrust coefficient 1 and 2, which in some way represent variation of thrust with speed and altitude and must be extracted from multiple points in the engine deck as well as consideration of multiple missions and specific data at specific altitudes. Ensuring that the points in the engine deck selected for the calculations were available for all vehicle sizes and technology packages, and that the conditions needed by AEDT had been considered in the EDS execution was extremely challenging and required several iterations.

Most of the robustness issues were ironed out throughout the second year, allowing the team to generate fleet level fuel burn results. However, additional issues were encountered when considering mission NO<sub>x</sub> due to the specific implementation of the Boeing Fuel Flow Method in AEDT which did not account for the potentially different behavior of modern combustors at altitude. Consideration of LTO NO<sub>x</sub> for year 2 also highlighted new robustness issues with the algorithms generating AEDT coefficients because these calculations explore a range of altitude/temperature/humidity conditions which had not been previously tested. The new algorithms developed have proven to be far more reliable in year 3, allowing for a nearly flawless link between the vehicle team and the fleet level assessments.

### **3. Safety Analysis**

#### **1. Motivation and Purpose**

Safety is an important element in the analysis and design of aircraft. Safety assessments are conducted with well-established processes and techniques that have traditionally required system definition at some level of detail. It follows that vehicle safety efforts increase with the design cycle, starting with very modest efforts in the conceptual design phase, and expanding in breadth and depth as the system definition progresses in preliminary and detailed design.

Studies of advanced vehicle concepts and vehicle technologies for future timeframes have traditionally placed a strong emphasis on the potential mission performance benefits that may be attained. Safety assessments are typically lacking, or at best modest and qualitative, by virtue of insufficient systems definition and inherent uncertainty in these future vehicles and technologies.

However, the need for a safety assessment remains ever present, especially for advanced vehicle concepts which stand to benefit the most from an early identification of safety issues. Vehicle concepts and enabling vehicle technologies may be better understood and proper direction given to their development so as to examine and adopt hazard mitigations.

The purpose of this research effort is to conduct a safety assessment that identifies and characterizes safety hazards for selected N+2 vehicle concepts and technologies, and in doing so outlines a formal safety assessment method suitable for the conceptual phase.

#### **2. Scope and State of Understanding**

The safety assessment study documented here incorporates the characterization of selected N+2 advanced vehicle concepts, described via technology collectors and integrated vehicle technologies, with the characterization of the anticipated NextGen operational environment for that timeframe. An understanding of the vehicle concept, the

technologies, the operating environment, and the interactions between them collectively underpin this safety assessment.

This understanding reflects the current state of knowledge by the authoring researchers, and is governed by the uncertainty inherent in future-state systems. The advanced vehicle concepts, its technologies, and the operating environment do not exist today and are currently the subject of R&D efforts so that they may be realized in the future. Much effort has been dedicated to vehicle and technology modeling which has required some level of detail in the definition of the technology collector, technologies impacts, and the resulting advanced vehicle concept performance. However this quantitative assessment is still partially speculative as the vehicle doesn't yet exist and technologies are under development. In addition, many safety issues and hazards require a level of detail in the systems definition that is beyond the current state of knowledge and thus can only be discussed qualitatively.

Although this safety assessment explicitly threads technology, vehicle, and airspace perspectives, the emphasis of the analysis remains chiefly at the vehicle level while assuming fully integrated technologies of interest. A characterization of the NextGen operational environment for the relevant N+2 timeframe is provided in a separate document entitled "NextGen Operational Environment Characterization".

### **3. Safety Assessment Method**

The safety assessment conducted follows a process that incorporates methodological features and techniques from well-established and broadly accepted safety assessment practices. This process is as follows:

Step 1: Vehicle Characteristics – Vehicle and technology information is collected starting at a high level with general design attributes and parameters. This information should provide a general idea of the vehicle concept and its capabilities. Basic performance metrics such as mission range or takeoff field length, and general mission parameters like cruise altitude and Mach number, are also be considered. The need for additional information may be identified in subsequent steps requiring iterations with step 1 to acquire, if possible, the necessary information.



Step 2: Hazards identification and qualitative description – Safety hazards are identified by researchers in a workshop setting with the intent of exhaustively considering the hazards domain space and to allow for necessary discussions. A qualitative description is developed for each safety hazard to elaborate on contributing factors, relevant aspects, and known or anticipated issues. Safety hazards take into consideration the vehicle concept (technology collector), the vehicle technologies assumed to be fully integrated into the vehicle, and the operating environment. All hazards and qualitative descriptions are documented. Qualitative descriptions are supplemented with review of relevant literature where appropriate. The documented hazards and descriptions are subject to multiple rounds of review.

The identification of hazards is structured by mission phase and within each mission phase by hazard contributing factors. The structure adopted for the present assessment is summarized below in Table 2. A safety hazard may be identified for multiple mission phases, and may pose a higher risk in some and lower in others. Safety hazards are also typically associated with multiple interacting contributing factors. The assignment of safety hazards to a single contributing factor simply reflects the primary type of contributing factor and is used as an aid to structure and organize the identification of hazards. Qualitative hazard descriptions developed in this step provide explicit reference to all contributing factors of a given safety hazard.

**Table 2. Structure of mission phases and hazard sources for hazards identification**

<i>Mission Phase</i>	<i>Hazard Contributing Factors</i>
Taxi In / Out	Vehicle Features
Takeoff	External Factors (Natural)
Climb	Operational Environment
Cruise	Human Factors
Descent	
Final Approach	
Landing	

Although the intent in this step is to be as exhaustive as possible, there is a strong emphasis on hazards and contributing vehicle features that are different from those known for aircraft in the operating fleet. Operating fleet refers to aircraft that may be out of production but currently in service, in production, or expected for entry into service, generally featuring a conventional tube-and-wing configuration. Although the conventional configuration is common throughout the operating fleet there are several technology generations for which minor differences in safety hazards exist. There are numerous safety hazards and contributing factors common to advanced vehicle concepts and the operating fleet. These common hazards are acknowledged but left outside the scope of this assessment to allow proper focus on the unique features of advanced vehicle concepts relative to the conventional configuration, resulting in new or different hazards. We identify a few representative examples of common hazards in this report for completeness.

In parallel a technology-centric safety assessment is conducted to qualitatively identify hazards for individual technologies and for cross-technology interactions. These technology centric hazards are related to vehicle centric hazards, and discussion on the relationship between them is provided.

Step 3: Quantitative Safety Assessment – Safety hazards identified are re-examined to determine if they can be quantitatively assessed. This requires each hazard to be researched in further detail to concurrently identify the following:

Appropriate system attributes and/or measures of performance that can be estimated to quantitatively characterize the safety hazard. These are proxy metrics for safety relative to the specific safety hazard in question.

The models (mathematical expressions, numerical algorithms, etc.) used to produce estimates for the proxy metrics, and the necessary inputs to the models.

Gaps in available data or state of current understanding of technologies, vehicles, and/or operating environment that limit or prevent a quantitative assessment.

The above identification of quantitative proxy metrics and corresponding models, or gaps thereof, is realized by researching the published literature related to the hazard under consideration. Required models and data are benchmarked against those that are available or can be acquired. Whenever gaps are found preventing or severely limiting the quantitative assessment the hazards in question are treated on a qualitative basis only. Otherwise, suitable proxy metrics and their corresponding mathematical models are documented in detail, noting in every case underlying theory and supporting references along with relevant data available. ***Hazards identified in Step 2 for which quantitative assessment can realized (Step 3) are highlighted with italic and bold font.*** The proxy metric models are implemented and exercised to produce estimates which are also documented in detail. To provide suitable context for the safety metrics estimates are produced for the advanced vehicle concept and for a reference vehicle. The reference vehicle, referred to as the Reference Technology Collector (RTC), is a current technology generation tube and wing aircraft with the same seating capacity.

#### **4. Vehicle Concepts and Technologies**

This safety assessment effort is conducted for three unconventional configuration vehicle concepts for the N+2 timeframe: The Hybrid Wing Body (HWB), the Box-Wing (BXW) concept, and the Mid-Fuselage Nacelle (MFN) concept. In all cases the vehicle is sized for a 300 passenger capacity. Vehicle definitions for these two aircraft are supported by prior and ongoing work conducted for ERA systems analysis.

Technologies considered have been investigated in prior work by the research team for ERA project systems analysis. These technologies are grouped to approximate Integrated Technology Demonstrators (ITD) selected by the ERA project and currently subject to R&D efforts by the ERA project or its subcontractors. The technologies used for this safety assessment and their mapping to ITDs is the work the research team in prior efforts and does not reflect official ITD data from NASA or its ITD subcontractors. Technology definitions, impacts modeling, and mapping

to ITDs has none the less been subject to review and has received approval by ERA systems analysis. The list of technologies and their mapping to ITDs is summarized below in Table 3.

**Table 3 Vehicle technologies and mapping to ERA integrated Technology Demonstrators (ITD)**

Technology	Integrated Technology Demonstrator
Natural Laminar Flow Wing	Active Flow Control Enhanced Vertical Tail Flight, Experiment and Engineered Surface
AFC Tail	
Advanced Aero Wing	
Damage Arresting Stitched Composites - Fuselage	Damage Arresting Composite Demonstration
Damage Arresting Stitched Composites - Wing	
Adaptive Compliant Trailing Edge	Adaptive Compliant Trailing Edge Flight Experiment
GTF Cycle	Second Generation Geared Turbofan Propulsion Integration
Natural Laminar Flow - Nacelle	
Over the Rotor Acoustic Treatment	
Highly Loaded Compressor - GTF	Highly Loaded Front Block Compressor
Lightweight CMC Liners	High OPR Axially Staged Combustor Integration
RQL Combustor (TALON X)	
-None-	UHB Integration for HWB
Continuous mold Line Link for Flaps	Flap Edge and Landing Gear Noise Reduction Flight Experiment
Landing Gear Integration – Main	
Landing Gear Integration - Nose	

## 5. Tube and Wing Vehicle Characteristics

The tube and wing configuration is the conventional airframe morphology dominant in the commercial airliner market. This aircraft design offers important advantages relative to unconventional configurations including a vast base of knowledge, experience, and empirical data. This historical advantage is reasonably expected to result in lower manufacturing costs, better understood flight dynamics and performance, better understood design tradeoffs, and broader acceptance for operators and passengers based on perceptions. The tube and wing aircraft for this study, shown in Figure 28, features a longitudinal tubular fuselage, cantilevered wings rooted on the lower part of the fuselage, under-wing mounted engines, and a conventional tail with horizontal and vertical surfaces.

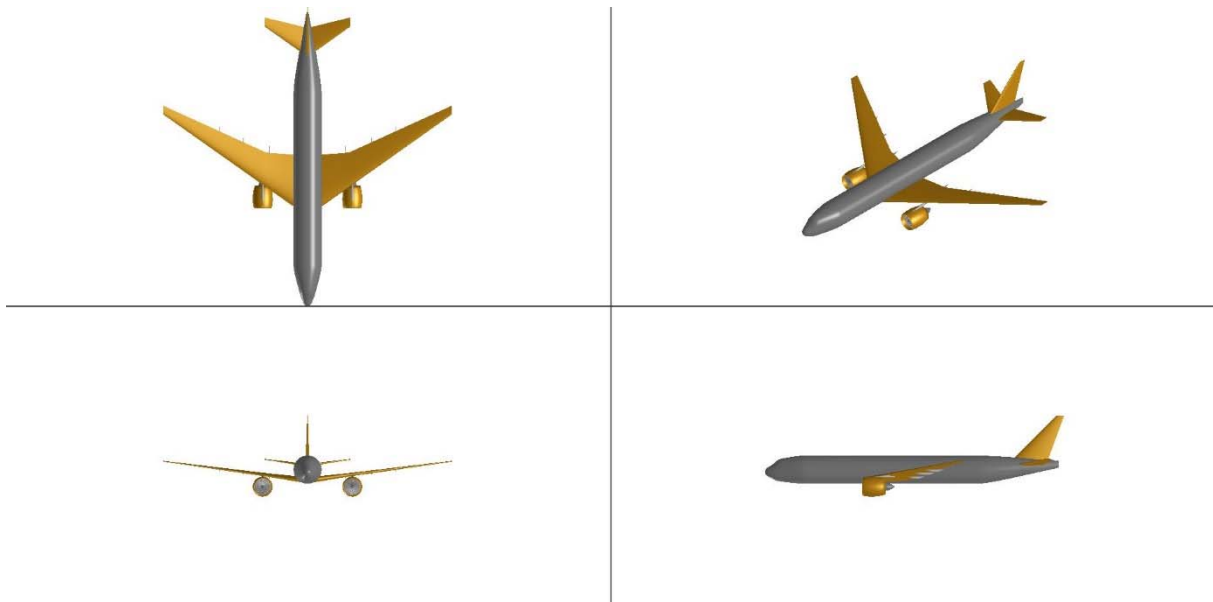


Figure 28 Geometric Model of the tube and wing aircraft

## 6. Hybrid Wing Body Vehicle Characteristics

The HWB aircraft used for this study, shown in Figure 29, features general attributes and characteristics consistent with most other HWB vehicles discussed in the published literature. This concept features a lifting center body that smoothly blends into the wing geometry thus providing a more favorable span wise loading compared to the traditional tube and wing configuration. One of the most obvious design

allowances stemming from this feature is a greater wing span. As a result the HWB offers greater aerodynamic efficiency for design cruise conditions and lower weight by virtue lower root-bending moments.

The benefits in empty weight and aerodynamic efficiency ( $L/D$ ) have a compounding effect on the sizing of the aircraft. Typically designs with this configuration have lower wing loading ( $W/S$ ) and thrust loading ( $T/W$ ) than tube-and-wing aircraft of the same seating capacity. The design point for the HWB in this study has a considerably lower wing loading and approach speed ( $V_{app}$ ) relative to that of the reference tube-and-wing configuration. Above mentioned design attributes and performance metrics are summarized in Table 4.

The HWB also features two podded engines placed above the aft portion of the center body, a key feature expected to contribute to engine source noise reduction by virtue of shielding effects, particularly for forward sources like fan noise and less so for jet noise.

Like many other designs for this configuration the HWB used in this study does not feature vertical or horizontal tail surfaces. Engine placement closer to the longitudinal centerline reduces differential thrust effects under engine out conditions, thus reducing the required yaw authority that typically governs the presence and sizing of a vertical tail. However the proximity of the engines close to each other poses the risk of losing both engines in case of any uncontained engine loss in one of them. The HWB design studied here assumes that yaw control provided by mechanisms other than a vertical tail are sufficient to satisfy control authority requirements stemming from asymmetric thrust or other similar conditions. Similarly, pitch authority is assumed to be satisfied by control mechanisms on the airframe trailing edge. However, no high-lift devices are assumed for this HWB design given the induced pitching moments that typically result and that are not expected to be sufficiently countered by a tailless pitch authority design. Ultimately, the absence of tail surfaces is carried into the design as an assumption about the successful realization of a stability and control system. The latter presents some unique inherent challenges and the details of a successful design are presently subject to much uncertainty.

While the lack of tail surfaces contributes to drag reduction, the airfoil characteristics associated with suitable pitching moment and the lack of high-lift devices ultimately result in a lower lift curve slope and a smaller  $C_{Lmax}$  compared to a conventional design. The resulting effect of degrading takeoff field length is countered by the benefits afforded by wing loading allowances, so that for this design the TOFL is comparable to the tube-and-wing as shown in Table 4.

The landing gear configuration for the HWB design is undefined. Landing gear configuration for other HWB designs in the published literature typically feature a wider wheel base track and comparable gear strut height relative to tube-and-wing configurations of the same passenger capacity. This landing gear features are incorporated as a reasonable assumption for the purpose of the safety assessment.

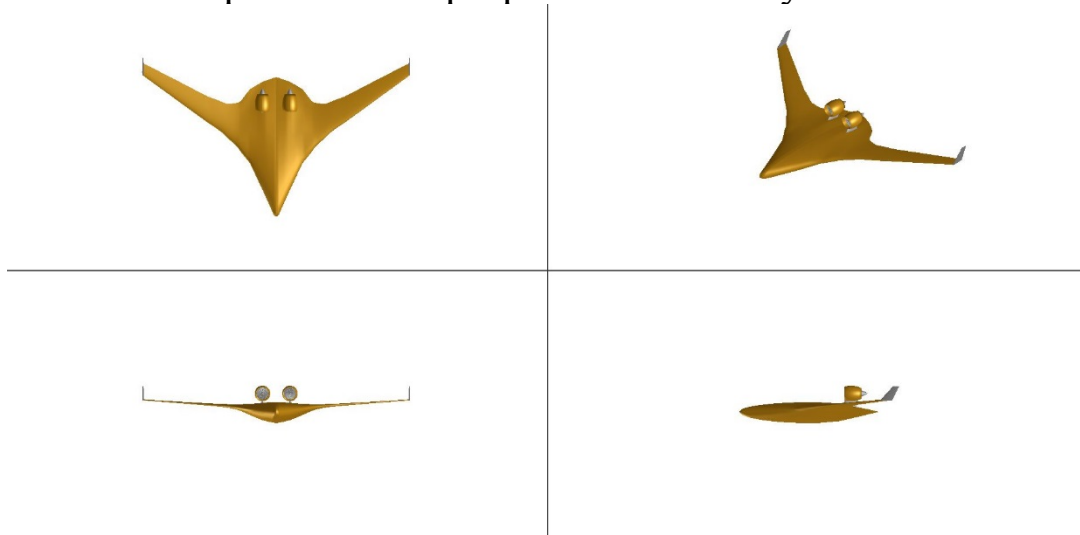


Figure 29 Geometric Model of the Hybrid Wing Body aircraft

## 7. Box Wing Vehicle Characteristics

The BXW aircraft features a conventional fuselage paired with an unconventional closed wing configuration comprised of two pairs of wings, one forward and one aft, as shown in Figure 30. The forward wing joins the fuselage on the lower half and is swept back, while the aft wing is swept forward and joins the airframe at the vertical tail. Both wings connect to each other at the tip with winglets so that the forward wing is low and the aft wing is high. Several other box wing concepts

have been proposed where the aft wing joins the forward wing at some inboard wing section without winglets, and several studies have examined the effect of wing joint placement on box wing configuration performance [Wolkovitch 1985, Gallman 1992, Kroo 1989].

A key feature of this concept is its potential to significantly reduce induced drag. The induced component is a significant portion of the total drag, resulting in a substantial reduction of drag compared to a conventional mono-wing with the same total wing area and span. Since both wings produce positive lift, the pitching moment can be trimmed out while maintaining minimum induced drag. Prandtl pointed out in the early days of aeronautics that the box wing configuration has the minimum induced drag if each of the two wings carries the same amount of total lift and has the same lift distribution [Prandtl 1924]. While Prandtl showed the benefit at low speed, others investigated its feasibility for large aircraft at transonic speeds [Lange 1974, Salam 2012]. At high speeds, the benefit of lower induced drag still holds. With the total wing area split between two wings, the wing thickness is reduced and so is wave drag.

Induced drag benefits are also typically justified via higher aspect ratio of each pair of wings, as well as winglet joints in a closed-wing configuration. For the BXW design considered in this study the total wing area (forward and aft wings) is comparable to that of the T&W RTC and the wing span is lower. The sizing of the box wing is also driven by fuel volume requirements, and the smaller chord of each pair of wings limits the high-lift mechanisms that can be integrated. Accordingly there are numerous competing effects affecting the aerodynamic performance of this concept.

Two ultra-high bypass (UHB) engines are pylon-mounted on the aft underwing. This engine placement circumvents engine ground clearance restrictions on engine diameter, and thus allows for greater fan diameters and bypass ratio values associated with the UHB concept.

The box wing configuration also features benefits and important challenges with regards to weights and structural design. Lower flutter speed and complex aeroelastic modes are an important area of concern. Weight penalties may be expected by virtue of the higher aspect ratio



wings and structural strengthening of the vertical tail where the aft wings join the airframe. Composite materials may be able to reduce these concerns with minimal impact. On the other hand the weight penalties associated with higher aspect ratio conventional cantilevered wings may be reduced for the box wing. The box wing concept also poses complex wing loading distributions in a highly coupled geometry; structural, aeroelastic, and failure mode response are not fully understood. Some loading and potential failure modes can be qualitatively treated, such as buckling of the aft wings during high wing loading conditions. Presently there is considerable uncertainty on the total magnitude of weight benefits or penalties associated with this wing configuration.

Both BXW and T&W cruise at Mach 0.84. Cruise altitude is also similar for the two concepts although the BXW remains between 39,000 and 43,000 ft, whereas the RTC T&W covers a portion of the cruise at 35,000. Important vehicle features and mission characteristics are provided in Table 4.

The BXW design considered in this study features no horizontal tail. Control system design will reflect the presence of forward and aft wings and wing chord limitations to provide suitable stability and control characteristics. Pitch authority is assumed to be similar to that of a canard configuration in the sense that both canard and wing, or forward and aft wings in the case of the BXW, provide lift. Landing gear configuration for BXW can be assumed to have a tricycle arrangement similar to that of T&W aircraft, with main landing gears housed in faired pods on the lower portion of the fuselage in a manner similar to high-wing transports. Landing gear strut height is not governed by engine clearance as is the case for underwing engine mounted T&W configurations, and thus can be expected to be smaller and driven by takeoff pitch up clearance requirements. Variations of height and width (wheel base) are discussed as part of hazards associated with ground maneuvers and airframe geometry.

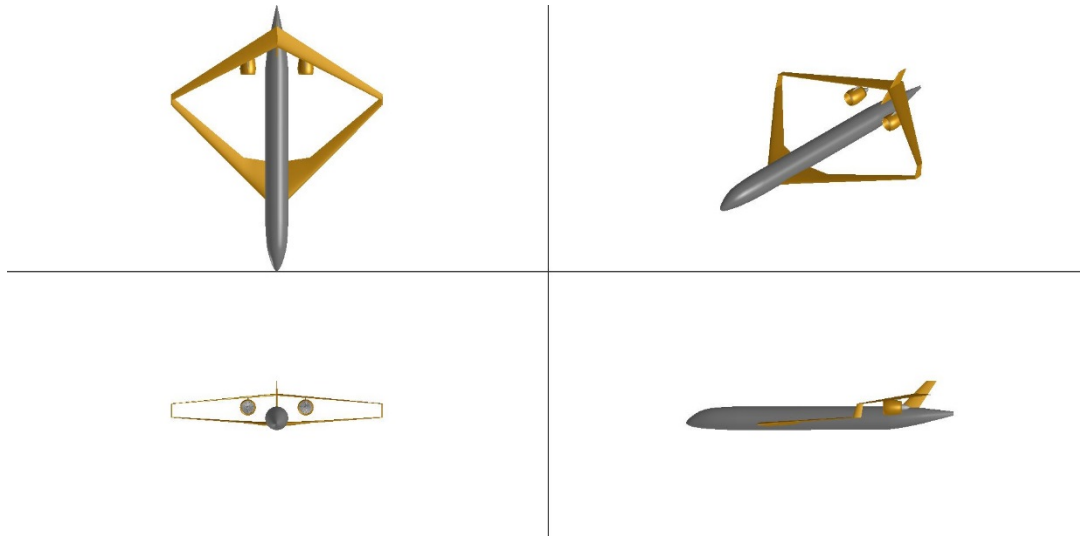


Figure 30 Geometric Model of the Box Wing aircraft

## 8. Mid Fuselage Nacelle Vehicle Characteristics

The MFN aircraft in this study is inspired by the Boeing 027A configuration proposed as part of the ERA N+2 advanced vehicle concept studies [Bonet 2011]. This concept is similar to a traditional tube and wing, but features a double-deck fuselage, fuselage mounted engines just above the wing, and a T-tail. The double-deck fuselage enables a shorter fuselage and allows the fuselage mounted engines to not interfere with the passenger compartment. Engine placement directly above and behind the wing offers fan noise shielding effects contributing to a lower overall noise exposure footprint. The T-tail avoids jet exhaust impingement on the horizontal tail surfaces. Lateral separation of engines may be reasonably assumed to be moderately smaller than that in under-wing mounting, reducing the vertical tail sizing for yaw authority for engine-out conditions.

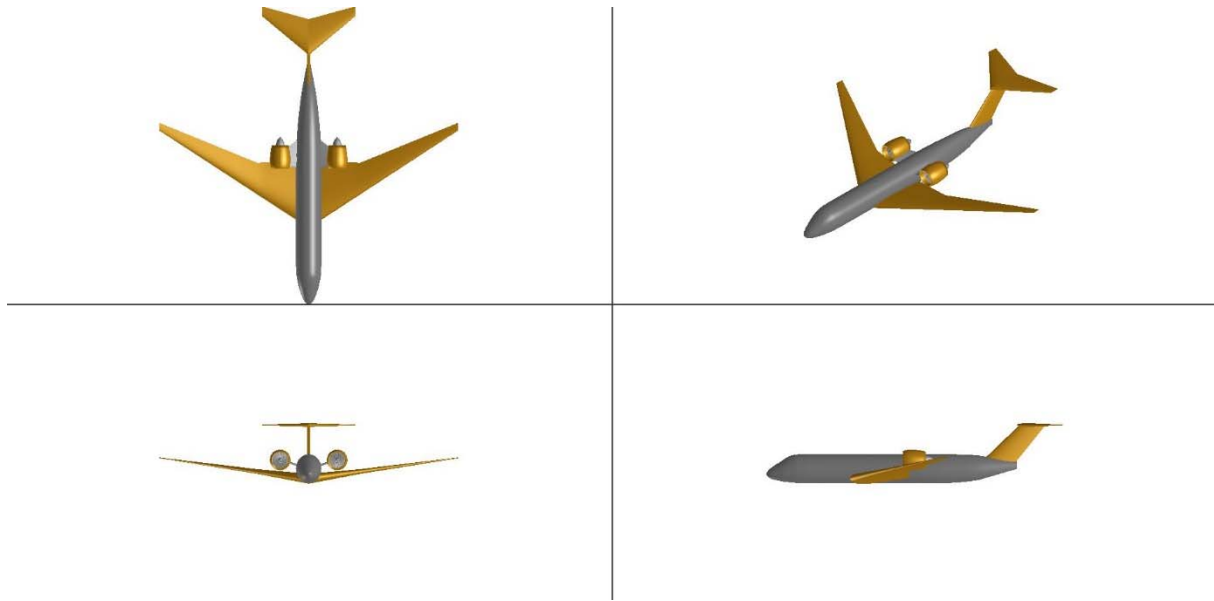


Figure 31 Geometric model of the B027 aircraft

Table 4 Summary of HWB design attributes and comparison with tube and wing

Vehicle Metric	ITD HWB	ITD BXW	ITD MFN	RTC T&W
$M_{Cruise}$	0.84	0.84	0.84	0.84
$Alt_{Cruise}$ [ft]	38585 – 43000 (Cruise Climb)	40192 – 43000 (Cruise Climb)	35000, 39000 (Cruise)	31000, 35000, 39000 (Cruise)
Range [nmi]	7530.00	7530.00	7530.00	7530.00
TOGW [lb]	422,174	463,816	447,238	553,976
OEW [lb]	222906.99	251692.12	225359.90	271550.10
$W_{fuel}$ [lb]	135217.37	148074.40	157828.60	218375.93
Thrust Loading $T/W_0$	0.27	0.29	0.28	0.29
Wing Loading $W_0/S$ [lb/ft <sup>2</sup> ]	52.00	101.00	136.00	133.34
Wing span b [ft]	221.57	200.00	181.82	194.82
$(L/D)_{Cruise}$	24.12	24.74	20.94	20.71
$C_{L, max @ Takeoff}$	0.99	1.41	1.80	1.81
Rate of Climb [ft/min]	436.75	493.32	291.04	324.18
Vapp[NMI/sec]	118.20	131.30	149.70	142.60
TOFL (Feet)	5646.00	6300.08	9595.66	9123.19

## 9. Hazards Identification

### 1. Taxi in / out

#### 1. *Vehicle features*

1. (HWB, BXW) Due to the increased wing span of the HWB compared to conventional configuration, impact with moving or stationary obstacles in the ramp area or taxiways is a hazard, particularly for outboard wing sections. Wing span is the aircraft attribute most immediately related to this hazard, and is used in practice to define airport compatibility groups. Wing span in excess of the upper limit of group VI requires amendment of current regulatory language for airport compatibility. In more general terms this hazard is characterized by the stationary and moving geometric footprint of the aircraft. Accordingly the general geometry of the aircraft, turning clearance radii for extreme points of the airframe, and landing gear configuration pertain to this hazard. The BXW has a smaller wing span compared to the T&W RTC, and thus it is a hazard reducing feature. However, there is uncertainty surrounding the landing gear layout and design which may be unfavorable for this hazard, and should be taken into consideration.
2. (HWB, BXW) Engines exhaust blast on trailing aircraft may feature jet velocity and/or jet temperature values that can cause damage to the trailing aircraft and the crew in the cockpit. Contributing factors to this hazard are the location of HWB engines on the aft center body near the centerline, comparable height of the trailing aircraft relative to HWB engine exhaust, and proximity of trailing aircraft to the HWB. Similar considerations apply to the BXW given engine placement in the aft portion of the airframe and at a height that can be comparable to trailing aircraft, although proximity to the centerline is less pronounced.
3. (HWB) Non-compliance with threshold markings, taxiway signage, and other markings may lead to hazardous events such as runway/taxiway incursions, or collisions with ground equipment,

other aircraft, ground personnel, or airfield structures. The contributing factors for this hazard are potentially reduced pilot visibility from cockpit driven by landing gear design (placement, height, etc.), and cockpit placement and design which affects the size of the obstructed area in front of the aircraft. Reduction of pilot visibility from the cockpit as compared with that of the conventional T&W can pose a hazard. Though in conceptual design the landing gear height is typically not completely determined, it is limited by pitch-up rotation at take-off and attitude at landing.

4. (HWB, BXW) Hazard reducing feature: Engine placement of HWB, i.e., engine placement over the body reduces the hazard of Foreign Object Debris (FOD) ingestion from contaminated runway surface. Similarly, engine placement on the BXW high above the ground also reduces the hazard for runway FOD ingestion.

2. *External Factors*

1. (HWB, BXW) Reduced visibility will increase the collision hazards. The environmental contributing factor for such reduced visibility is typically related to weather conditions such as fog, rain, hail, snow etc.
2. (HWB, BXW) Contributing external factors for this collision hazards include inadequate airport design for accommodating new vehicle features, including proper taxiway/runway separation, parking footprint at gate, taxiway/runway width, curbs, etc.

3. *Operational Environment*

1. (HWB, BXW) Degradation or loss of situational awareness resulting from failure/loss of ground movement services (ADS-B, ASDE-X, radio or data communications) are a contributing factor for collisions and non-compliance of ATC surface instructions and/or surface markings, particularly under reduced visibility conditions.

4. *Human Factors*

1. (HWB, BXW) Contributing factors due to human factors are degradation or loss of situational awareness, head down time during data communication, poor pilot reaction time and assessment of distances for turns and following in-trail. Assessment for turns and in-trail following are driven by the pilot's familiarity with the new configurations of HWB and BXW unconventional dimensions and geometry configuration. This may be more affected in HWB as compared to that of BXW because of its unfamiliar body shape.
2. (HWB, BXW) Collision hazard may result due to increased pilot work load. Contributing factors such as unfamiliar design features of the HWB and BXW, such as its shape and size (dimensions), may lead to improper maneuvering leading to increased pilot workload.

**2. Takeoff**

1. *Vehicle features*

1. (HWB, BXW) Hazard related to centerline deviation / runway excursion is possible during cross-winds or windy conditions. Low wing loading of both vehicles relative to RTC T&W, as well and the lateral profile of HWB vehicle are contributing features for the susceptibility to gusts, particularly in the case of HWB.
2. (HWB, BXW) Hazard due to stall is considered. The lift curve slope and  $C_{Lmax}$  for the HWB and BXW are considerably different to the reference T&W and act as contributing factors, particularly in the presence of tail or vertical gusts
3. (HWB, BXW) Runway deviation/excursion/overrun hazards. Decision speed and its impact on balanced field length analysis are relevant metrics governed by key conditions at takeoff such as weight, thrust, density, and runway conditions.

4. (BXW) Buckling is an issue with the aft wing during take-off due to high lift configuration, as this would aggravate the compressive loads on the aft wing and make them more susceptible to buckling.
5. (BXW) There is a possibility of potential tail strike during the rotation of pitch up maneuvering. The rotation geometric limitation is a function of takeoff performance, landing gear placement, weights and balances, etc. which should be considered during design of landing gear.
6. (HWB) Engine performance degradation is a critical hazard during the takeoff phase. Engine performance may be reduced during and after rotation, if pitch angle is high enough. Of particular relevance is the placement of ultra-high bypass ratio engines over the aft center body as a contributing factor. Flow may be obstructed by center body and can affect engine intake, resulting in critical performance degradation when the engines are required to perform at full or close-to-full power during takeoff.
7. (HWB) Hazard reducing feature: Proximity of engines to plane of longitudinal symmetry mitigates thrust asymmetry during engine out condition. This feature is applicable to all phases of flight. Since engine out is critical during take-off and climb out, this feature on HWB aids in reducing the hazard due to the engine out. However, in case of any uncontained engine loss, the proximity also poses the risk of losing the second engine.
8. (HWB) Hazard reducing feature: HWB has good takeoff performance and lower TOFL relative to comparable payload tube and wing configuration, thus reducing takeoff runway overrun hazards. The take-off performance is dependent on the  $C_L$  max and ability to trim.
9. (HWB, BXW) Hazard reducing feature: Engine placement of HWB and BXW reduces the hazard of FOD engine ingestion from contaminated runway surface.

10. (BXW) Hazard aggravating feature: Due to engine placement aft and above the center of gravity there is potential for disrupting pitch control characteristics during engine out conditions. This is applicable to all phases but especially critical during take-off due to proximity to the ground.
11. (BXW) Hazard reducing feature: The wings can be designed such that forward wing stalls first with increasing angle of attack and hence provides better stall recovery using the aft wing with acceptable loss of altitude.
12. (BXW) Hazard aggravating factor: Engine placement may lead to aft wing structural failure or severe damage in case of uncontained fan/engine failure, may affect elevator /control surfaces, especially due to increase in fan size (fan blade size, weight, inertia). This hazard is applicable for all mission phases.

2. *External Factors*

1. (HWB) Centerline deviation / runway excursion are hazards that may be associated with external factors such as cross-winds. The lack of a vertical tail and smooth airframe span wise profile may lead to lower susceptibility to cross wind gusts for the HWB. However, a lower weight and wing loading have the opposite effect and increase the risk of trajectory deviation. Overall these two effects may roughly produce no net difference relative to the reference T&W vehicle under these conditions.
2. (BXW) Centerline deviation / runway excursion are hazards that may be associated with external factors such as cross-winds. The trim and control due to non-planar loads can be challenging and increase the pilot work load.

3. *Operational Environment*

1. None



4. *Human Factors*

1. (HWB, BXW) Human factor issues related to decision speed execution are considered as a hazard for the runway excursions. Pilots failing to initiate the aborted take-off within the assumed reference time intervals are a contributing factor towards the runway excursions.

3. **Climb**

1. *Vehicle features*

1. (HWB, BXW) Loss of separation is a precursor to the collision hazard. Differential climb performance due to achievable climb rates by respective vehicles is considered as the contributing factor. Climb performance is dependent on many other degrees of freedom. Since the vehicles are being considered at conceptual level, the climb rates can be made comparable to that of T&W. For the HWB engine shielding may allow for elimination of cutback (during Optimal Profile Climb), which would lead to faster climb, higher climb rate.
2. (HWB, BXW) Engine out condition is a constraint that needs to be incorporated in the design. Engine out condition during climb, in a high density airport scenario, may lead to loss of separation and presents a collision hazard. Inability to maintain climb rate for NextGen operations is a critical hazard, for instance if performing a steep climb or high-precision departure procedure with a non-operating engine
3. (HWB, BXW) Wake encounters, gust encounters and microburst encounters during climb are a hazard. The ability to withstand gusts of some intensity presents a performance constraint for the aircraft. Such encounters may lead to reduction or loss of separation for which air traffic management would have to respond with instruction amendments. Contributing factors include airframe geometry and low wing loading.

2. *External Factors*

1. (HWB, BXW) Microbursts immediately after takeoff can pose ground collision hazard by making the aircraft uncontrollable or causing an unrecoverable loss of altitude.

3. *Operational Environment*

1. (HWB, BXW) Collision hazard due to loss of separation can be caused due inability to maintain a 4D trajectory / RNAV/RNP trajectory. The contributing factors for such scenario can be loss of functionality of operating equipment that provides the necessary information to maintain aircraft trajectory, climb profile, attitude, and overall configuration for climb out performance. Any other external factors such as wind conditions would aggravate the risk posed due hazard.

4. *Human Factors*

1. None

**4. Cruise**

1. *Vehicle features*

1. (HWB, BXW) Loss of separation as a precursor to the collision hazard. The contributing factors are primarily driven by higher/ lower cruise rates relative to other air traffic at the same altitude. Non-compliance of air traffic services cruise speed instructions are an aggravating factor, especially on highly coordinated operations such as injection into an in-trail self-separation airway.
2. (BXW) Hazard reducing feature: Control and stability are good for the joined wings in normal flight and at the stall [Wolkovitch 1985].

2. *External Factors*

1. (HWB, BXW) Loss of separation leading to collision hazard that is aggravated by poor weather conditions affecting aircraft

performance, controllability, and pilot workload and situational awareness.

3. *Operational Environment*

1. (HWB, BXW) Collision hazard due to loss of separation can be caused due inability to maintain a 4D trajectory / RNAV/RNP trajectory. The contributing factors for such scenario can be loss of functionality of operating equipment that provides the necessary information to maintain aircraft trajectory, attitude, and overall configuration for cruise. Any other external factors such as wind conditions would aggravate the risk posed due hazard.

4. *Human Factors*

1. None

5. **Descent**

1. *Vehicle features*

1. (HWB, BXW) Loss of separation leading to collision due to differential descent performance relative to other traffic.
2. (HWB, BXW) Engine out condition during steep descent, in a high density airport scenario, may lead to loss of separation leading to collision hazard.
3. (HWB, BXW) Wake encounters, gust encounters and micro burst encounters during descent present a critical hazard. Contributing factors include airframe planform and low wing loading which is much lower than at the start of the mission. Lower wing loading exacerbates gust susceptibility. Low thrust setting is typical for descent, affecting response to gust encounters and micro-bursts. In addition a steep descent as would be conducted for a NextGen steep CDA procedure further aggravates susceptibility to this hazard and increases potential loss of altitude.
4. (HWB, BXW) Stall during descent is a hazard. The lift curve slope and  $C_{Lmax}$  of the new configurations in comparison with

T&W vehicle are contributing factors. Aggravating factors include external conditions such as tail wind/ cross wind.

5. (HWB) Engine performance is susceptible to negative air mass inflow conditions due to engine placement on top of the aft body if aircraft is at high angle of attack. Flow separation or distortion around and downstream of the upper airframe surface may lead to flow distortion at the engine inlet plane, and thus to engine performance degradation or stall, degraded engine throttle up response, etc. Steeper pitch angles may increase susceptibility to stall, with gusts as a contributing factor. During steep descents throttle setting is low, which is also a contributing factor. Combinations of airframe stall and engine performance degradation while at low throttle setting may occur and present a significant hazard. On the other hand engine intake may promote upper surface flow and delay aerodynamic stall.

2. *External Factors*

1. (HWB, BXW) Loss of separation leading to collision hazard may be caused due to inconsistent descent rate/ loss of descent rate. Poor weather conditions are an external contributing factor for inconsistent and unexpected performance relative to air traffic instructions for arrival.

3. *Operational Environment*

1. (HWB, BXW) Collision hazard due to loss of separation can be caused due inability to maintain a 4D trajectory / RNAV/RNP trajectory for arrivals, particularly in the context of highly coordinated operations in a high density airport. The contributing factors for such scenario can be loss of functionality of operating equipment that provides the necessary information to comply with arrival air traffic service instructions and arrival procedures.

4. *Human Factors*

1. (HWB, BXW) Crew may experience excessively high workload in the management of hazardous conditions, particularly those arising from combinations of individual hazards, such as aerodynamic and engine stall while attempting to comply with a high-performance arrival in tightly coordinated procedures with other traffic in close proximity. External factors such as poor weather or loss of operational services are significant aggravating factors.

**6. Final Approach**

1. *Vehicle features*

1. (HWB, BXW) Loss of separation leading to collision due to differential approach speeds, or non-compliance of final approach profile
2. (HWB, BXW) Wake encounters, gust encounters and micro burst encounters during approach is a significant hazard. Contributing factors include airframe plan form, low wing loading.
3. (HWB, BXW) Occurrence of stall during final approach due to unfavorable conditions relative to nominal final approach configuration performance, including excessive upwind or down wind.
4. (HWB, BXW) Hazards during go-around include initiation of go around at a wrong decision height. Accident/ Incident can happen because of decision height miscalculations and/or delayed execution of go around. Vehicle attributes such as weight, load factor, pilot/engine response time would contribute to the decision height deviations which would lead to the failed go around and potentially to ground collisions. The operational requirements for conflict resolution demand certain vehicle performance in terms of turning rate, ability to climb to pattern height, maintain altitude, and descend. Any

large deviations may lead to loss of separation hazard. Engine power setting will be a contributing factor.

5. (HWB, BXW) Un-stabilized approach is a precursor for runway collision, excursion, and incursion hazards. Factors and interactions among the various factors such as decent angle,  $V_{app}$ , stall and descent rate may lead a stabilized approach performance to un-stabilized approach.
6. (HWB) HWB wake vortices are weaker and shorter-lived relative to comparable weight tube-and-wing configuration, which is a hazard reducing feature. This feature is applicable in all phases of flight namely, take-off, climb out, cruise, descent and approach where there is a chance of wake encounter. This feature is more applicable in the final approach where wake encounter is a critical limitation for vehicle separation.
7. (HWB) The large UHB engines on the HWB might make it susceptible for engine stall at higher angles of attack. Higher angles of attack are susceptible to airframe stall and may lead to engine stall. On the other hand engines may delay aerodynamic stall by facilitating flow on the upper surface. Above scenarios are very dependent on vehicle attitude and the operating environment.
8. (HWB) Engine performance is susceptible to negative air mass inflow conditions due to engine placement on top of the aft body if aircraft is at high angle of attack. Flow separation or distortion around and downstream of the upper airframe surface may lead to flow distortion at the engine inlet plane, and thus to engine performance degradation or stall, degraded engine throttle up response, etc. Steeper pitch angles may increase susceptibility to stall, with gusts as a contributing factor. Combinations of airframe stall and engine performance degradation while at low throttle setting may occur and present a significant hazard. On the other hand engine intake may promote upper surface flow and delay aerodynamic stall.

2. *External Factors*

1. None

3. *Operational Environment*

1. (HWB, BXW) Collision hazard due to loss of separation can be caused due inability to maintain a 4D trajectory / RNAV/RNP trajectory. The contributing factors for such scenario can be loss of functionality of operating equipment that provides the necessary information to maintain the aircraft configuration for final approach. Any other external factors such as wind conditions would aggravate the risk posed due hazard.

4. *Human Factors*

1. None

**7. Landing**

1. *Vehicle features*

1. (HWB, BXW) Hazard related to centerline deviation / runway excursion is possible during cross-winds or windy conditions.
2. (HWB) Wing tip strike is a hazard during cross wind landing with sideslip approach. Contributing factors are vehicle yaw controllability, wing span, landing gear height and location. Increased susceptibility to aborted landing during cross-wind conditions due to insufficient yaw-authority required for crabbed approach, thus requiring sideslip in final alignment with runway centerline. At conceptual design stage, the means for yaw authority for a tail less HWB is not yet considered.
3. (HWB, BXW) Lack of proper high speed runway exit performance will lead to hazards such as tip over, unequal forces on landing gear leading to landing gear failure, etc. Lateral mass distribution, in case of HWB, and landing gear configuration and location in case of either of the new vehicles, will affect aircraft stability on the ground while performing a high-speed runway exit.

4. (HWB, BXW, MFN) Stability and control issues during landing due to non-planar loads and engine thrust contributing to longitudinal stability may lead to loss of control hazard of the box wing.
5. (HWB, BXW) Hazard reducing feature: Engine placement feature of HWB and Box wing, i.e., engine placement over the body for HWB and under the aft wings for BXW, reduces the hazard of FOD engine ingestion from contaminated runway surface.
6. (HWB) Hazards related to evacuation procedures due to HWB configuration as in passenger evacuation time, risks, and the impact of passenger allocation in center body. These hazards are not really related to landing, but are related to evacuation procedures and emergency procedures after an emergency landing such as descent into terrain or descent on to water. Location of passenger cabin and exits must be considered in the scenario of a water evacuation (aircraft ditching) to ensure that exits remain above the water line.
7. (MFN) Hazards related to evacuation procedures using emergency exits located above the wing, exit area is in front of engine face which presents a hazard to evacuating passengers

2. *External Factors*

1. (HWB, BXW) Reduced visibility will increase the collision hazards. The environmental contributing factor for such reduced visibility is typically related to weather conditions such as fog, rain, hail, snow etc.
2. (HWB, BXW) Collision hazard due to contributing external factors such as inadequate airport design for accommodating new vehicle features, including separation of taxiways, parking footprint at gate, taxiway/runway width, curbs, etc.

3. *Operational Environment*

1. None



4. *Human Factors*

1. None

## **10. Common Hazards and Contributing Factors**

(Representative sample of hazards applicable to conventional T&W and unconventional vehicle concepts alike)

1. (HWB, BXW) Human Factors such as non-compliance of procedures, excessive pilot workload, human performance stressors, loss of situational awareness, fault identification, leading to hazards such as loss of control and loss of separation.
2. (HWB, BXW) Accident/ Incident due to contributing factors such as pilot error during Visual Flight Rules (VFR) for failed approach/landing leading to aircraft accident / collision, runway condition from weather such as wet/dry snow.
3. (HWB, BXW) Any failure of NextGen technologies, such as ADS-B, Data Comm., GPS for RNP etc., yields a hazard or is a contributing factor to a hazard. They are applicable to all phases of flight, but especially in high-density airspace during departure and arrival.
4. (HWB, BXW) Steep climb, steep descent procedures specific to airports which demand high performance could be a potential source for the collision hazards in case some traffic deviate from their nominal performance.
5. (HWB, BXW) For loss of separation hazard which could potentially lead to collision hazard, some of the contributing factors include changes in trajectory for severe weather conditions, wrong altitude flying, and loss of situational awareness.
6. (HWB, BXW) Runway contamination with potential FOD (Foreign Object Debris) or wildlife strikes.
7. (HWB, BXW) Loss of control of the aircraft with contributing factors such as icing on wings during

cruise/descent/landing, failure or unreliability of any part/subsystem.

## **11. Technology Hazard Assessment**

### **1. Individual Technologies**

#### *1. AFC Enhanced Vertical Tail (12A)*

1. (HWB, BXW) Technologies that improve the aerodynamic properties of airframe components such as Low Interference Nacelle, Natural Laminar Flow Nacelle, Natural Laminar Flow Wing, and Advanced Aero Wing, may observed sharp loss or degradation of said aerodynamic benefits after debris impact such as hail or debris accumulation such as icing deposit or insects. In general, benefits from NLF may be degraded due to wildlife impact (insects, birds), hail/precipitation impact, icing, and may induce unsafe conditions. This is applicable to all phases of flight and relates to the aforementioned external factors.
2. (HWB) AFC tail technology cannot be used on tail less configurations of the HWB.

#### *2. Damage Arresting Composites (21A)*

1. (HWB, BXW) Response of damage arresting materials to external factors such as lightning, debris impingement, and the effect of other conditions such as humidity or salinity on long-term reliability and properties are not fully understood and may present significant hazards relative to said external factors across all mission phases.
2. (HWB, BXW) Response of damage arresting materials to fire, release of potentially noxious gases from composite burning poses a potential hazard and has direct implications on the design of emergency procedures in case of fire such as requirements for contention and extinction, or passenger

evacuation. This hazard applies to all mission phases in response to any factors leading to the occurrence of fire.

3. *Second Generation Geared Turbo Fan (35A)*

1. (HWB, BXW) Geared Turbo Fan (GTF) / Ultra High Bypass (UHB) has larger face profile than conventional engines, increases the risk of debris ingestion (e.g. bird strike/ingestion), and is dependent on engine placement. As in current the designs studied in this effort the risk of debris ingestion from runway will be decreased due to the engine placement farther from the ground or over the aircraft body. However, due to their proximity an uncontained engine failure increases the risk of failure of the other engine. This is an inherent system property relevant in phases where wildlife and other forms of debris may be present, primarily takeoff, (initial) climb out, descent, final approach, and landing.
2. (HWB, BXW) Greater size of UHB engines relative to those in the RTC may increase an uncontained Zonal Hazard, meaning that a significant engine failure has the potential of leading to the propagation to adjacent system zones. Due to the sheer size, in some of the worst cases such as physical loss/detachment of the engine from the pod/pylon the resulting hazards to other the components and systems that would be in the proximity of that engine are significant.
3. (HWB, BXW) Over the rotor acoustic treatment introduces metal foam liners as a noise reduction technology. Failure of these liners may lead to impingement with fan blades, ingestion, and potential loss of the engine, and contamination of the environment (including runway) posing a hazard for the subsequent aircraft in operation.

4. *Flap Edge Landing Gear Noise Reduction Flight Experiment (50 A)*

1. (HWB, BXW) Metal fairings or metal parts in fairings used for landing gear may become dislodged and result in runway debris that can damage other aircraft using the runway.

## 2. Cross-Technology Hazards

The cross technology interactions are captured in Table 5; instances of the number zero indicate that the technology is not present and cross-technology effects do not apply, and instances of the number 1 denote existence of cross-technology effects. These possible interactions are explained further in this section.

**Table 5 Technology Interactions Table**

ITD	Technology	12A	21A	21C	30A	35A	40	50A	51A
		Natural Laminar Flow Wing AFC Tail Advanced Aero Wing	Damage Arresting Stitched Composites - Fuselage Damage Arresting Stitched Composites - Wing	Adaptive Compliant Trailing Edge Highly Loaded Compressor - GTF	GTF Cycle	Natural Laminar Flow - Nacelle Over the Rotor Acoustic Treatment	Lightweight CMC Liners RQL Combustor (TALON X)	Continuous mold Line Link for Flaps Landing Gear Integration - Main Landing Gear Integration - Nose	-None-
12A - Active Flow Control Enhanced Vertical Tail Flight, Experiment and Engineered Surface	Natural Laminar Flow Wing	■							
	AFC Tail	■							
	Advanced Aero Wing	■							
21A - Damage Arresting Composite Demonstration	Damage Arresting Stitched Composites - Fuselage		■						
	Damage Arresting Stitched Composites - Wing	P	■						
21C - Adaptive Compliant Trailing Edge Flight Experiment	Adaptive Compliant Trailing Edge	P	P	■				P	
30A - Highly Loaded Front Block Compressor	Highly Loaded Compressor - GTF	S		■					
35A - Second Generation Geared Turbofan Propulsion Integration	GTF Cycle	S			■				
	Natural Laminar Flow - Nacelle				■				
	Over the Rotor Acoustic Treatment				■				
40 - Low NOx Combustor Integration (High OPR Axially Staged)	Lightweight CMC Liners					■			
	RQL Combustor (TALON X)					■			
50A - Flap Edge and Landing Gear Noise Reduction Flight Experiment	Continuous mold Line Link for Flaps	P	P				■		
	Landing Gear Integration - Main						■		
	Landing Gear Integration - Nose							■	
51A - UHB Integration for HWB	-None-								■

Note that the AFC tail technology is present for the BXW and hence that column would be blank in the case of BXW chart.

1. *NLF on airframe components and Damage Arresting Materials*
  1. (HWB, BXW) Inability to attain required tolerances, surface finish, or presence of manufacturing / airframe integration defects with composites decreases the effect of laminar flow region.
2. *Soft Vane and Over the Rotor Acoustic Treatment*
  1. (HWB, BXW) Liners placed closed to the fan as an acoustic treatment might not sustain potential fan blade tip rub and

induces hazard of detachment and ingestion into the engine leading to an engine failure.

2. (HWB, BXW) Internal failure of the soft vane technology (porous surface or internal vane chambers) presents the potential hazard of propagating and increases the hazard of blade failure with propagating effects in downstream sections of the engine.
3. *Low Interference Nacelle with NLF Wing / Nacelle*
  1. (HWB, BXW) Low Interference Nacelle on GTF poses the hazard of changing the NLF characteristics on the wing and vice versa as a result of engine placement and other engine-airframe integration factors. The HWB with upper surface engine placement may present unique conditions requiring especial attention.
4. *Adaptive Compliant TE – NLF wing/ CML Flaps/ Advanced Aero Wing*
  1. (HWB, BXW) Improper functioning or failure of Adaptive Compliant TE may decrease / worsen the NLF condition of the wing.
5. *Geared Turbo Fan (GTF) – AFC Tail*
  1. (BXF) If AFC system is powered by engines, rather than an alternate system, failure of the engine would significantly degrade or eliminate air bleed for the AFC mechanism on the vertical tail rudder, thus reducing yaw authority necessary for engine out conditions. This hazard exists in low-speed flight regimens when the AFC would be active, such as takeoff, initial climb, final descent/approach and landing.

## 12. Safety Metric Proxies and Hazard Quantification

### 1. Taxi-in

#### 1. Vehicle Clearance / Strike

Wing strike with the aircraft or terminal structure depends on wingspan limits by aircraft design group for airport compatibility. Vehicle compatibility and wing strike comparisons are made based on airframe design group considerations.

#### 2. Airframe Design Group & Airport Category

Design group and Airport categorization for aircraft-airport compatibility is based on wing span and approach speed as documented in FAA advisory circular Operational Characterization AC 150/5300-13 [FAA 1989], shown in Table 6. Both parameters are used to determine suitable compatibility between an aircraft and an airport. The design group captures the size, geometric footprint, and general spatial features of an aircraft by way of wing span as a representative and suitable indicator. Accordingly it is used for guidance on the spatial requirements that an airport must meet to accommodate aircraft of a certain design group. In this sense wing span is an aircraft attribute directly related to vehicle clearance and strike hazards. In a similar sense approach speed is used as a suitable indicator of the type of traffic that can be accommodated by an airport in terms of runway characteristics, required air traffic services, and supporting infrastructure.

**Table 6 Design Groups based on wing span and Vapp**

Design Group		Airport Category	
Group	Wingspan Limit(Feet)	Category	Approach Speed (Knots)
I	< 49	A	< 91
II	49 to 78	B	91 to 120
III	79 to 117	C	121 to 140
IV	118 to 170	D	141 to 165
V	171 to 213	E	>166
VI	214 to 261		

### 2. Wing Span & Vapp

**Table 7 Airport Compatibility Vehicle Characteristics**

Vehicle	Wing Span (Feet)	Vapp (Knots)
ITD HWB	221.57	118.20

ITD BXW	200.00	131.30
ITD MFN	181.82	149.70
RTC TW	194.82	142.60

Wing span and approach velocity for the HWB, BXW and RTC are summarized in Table 7. Based on Design Group and Airport Categories in Table 6, according to wing span limit, the RTC vehicle is in design group of V whereas HWB falls into is in design group VI, and the BXW and MFN in group V. Approach speed category for the RTC and BXW is D whereas HWB is category B. With regards to airport compatibility the HWB and BXW are more restricted than the RTC and BXW in terms of wing span, and the opposite is true for approach velocity. In general, the historical and current tube-and-wing fleet shows strong correlation between size (wingspan), weight, and approach speed. Accordingly, it is typical for airports certified to handle greater design groups to also be certified for greater approach velocity categories. Wingspan of the HWB thus emerges as a constraining attribute and can be interpreted as a greater hazard of wing strike relative to the RTC or BXW. Conversely, mitigation of this hazard for the HWB by restricting operations to Design Group VI airports limits airport accessibility/compatibility. On the other hand the BXW presents a diminished airframe strike hazard by virtue of its lower wing span and Design Group, also granting it greater airport accessibility.

### **13. Takeoff**

#### **1. Runway Overrun**

Balanced Field Length (BFL), decision speed, and human factors such as crew response time to reject the take-off before the decision speed play a major role in the runway overrun hazards, especially during engine out conditions. BFL and decision speed are chosen as safety proxies for runway overrun hazard. Human factors related causes are not explicitly considered or analyzed.

## 2. Balanced Filed Length (BFL), Decision Speed

Balanced field refers to that where the required accelerate-go distance during an engine-out event equals the required accelerate-stop distance under the same conditions. Rejected Take Off (RTO), an accelerate-stop scenario, is initiated for various reasons, not just due to engine out. Figure 32 (Source: Ref. [FAA Pilot Safety]) presents RTO initiation reasons for a sample of 97 events.

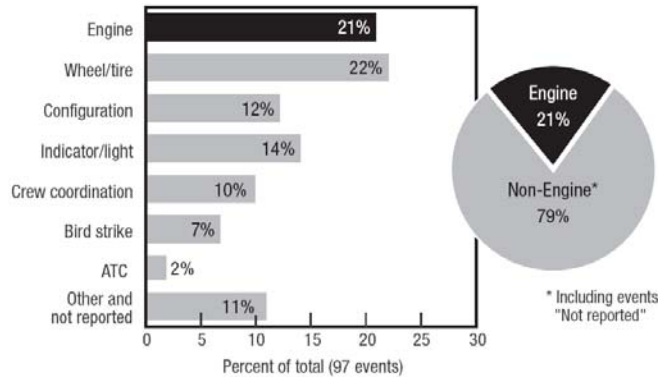


Figure 32 Rejected Take Off (RTO) causes [FAA Pilot Safety]

RTO is considered in determining the runway length/ take off field length requirements. Federal Aviation Regulations (FAR) take off field length is determined by considering the most limiting case of the three criterion given below, and are represented pictorially in Figure 33, where  $V_1$  denotes decision speed.

1. All engine go distance which is 115% of the actual distance required to accelerate, lift off and reach a point of 35 feet above the runway with all engines operating.
2. Engine out accelerate go distance is the distance required to accelerate with all engines operating, have one engine fail at  $V_{EF}$  (also referred to as  $V_{Crit}$ ) at least one second before  $V_1$ , continue take off, lift off and reach a point of 35 feet above the runway surface at  $V_2$  speed.
3. Accelerate stop distance is the distance required to accelerate with all engines operating, have an engine failure at  $V_{Event}$  (also referred to as  $V_{Crit}$ ) at least one second before  $V_1$ , recognize the event, reconfigure for stopping and bring airplane to a full stop using maximum wheel braking power.



Reverse thrust is not used to determine the FAR accelerate stop distance, except for wet runway case.

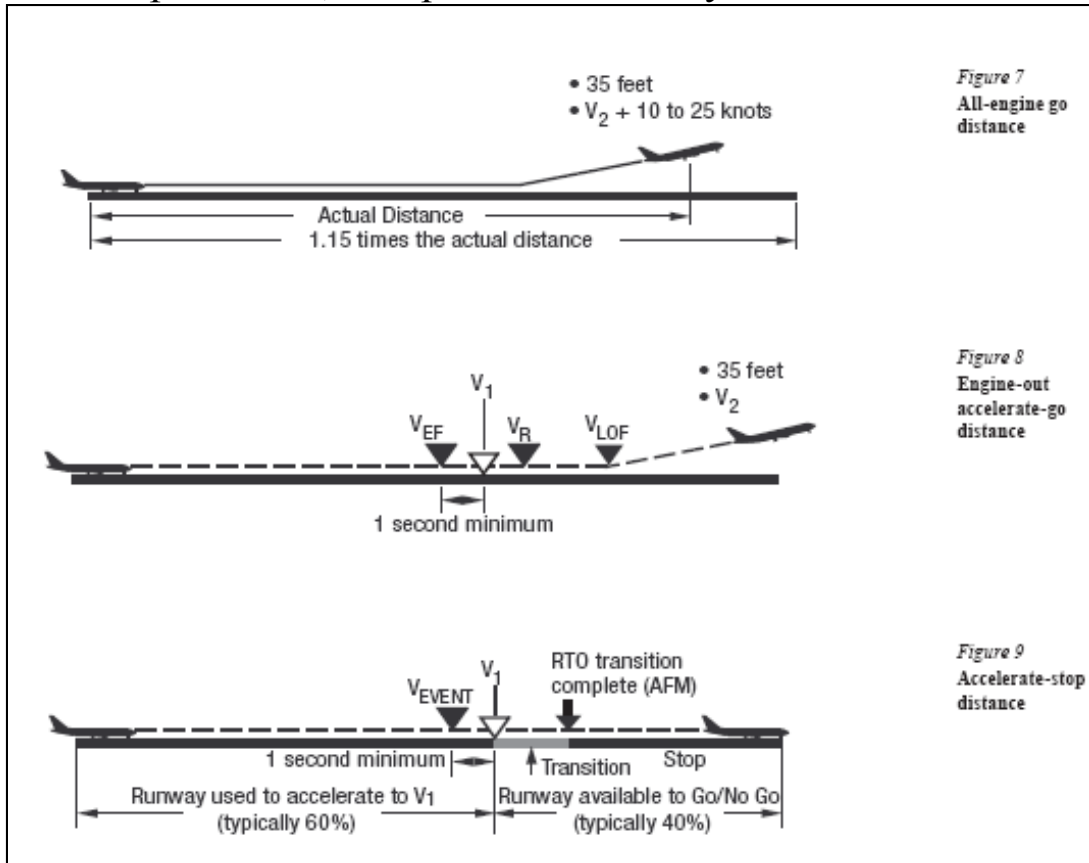


Figure 33 FAR requirements for Runway Length [FAA Pilot Safety]

Decision speed  $V_1$  is the maximum speed at which the crew can decide to reject the take-off, and is ensured to stop the aircraft within the limits of runway, considered from FAR 25.107.[Airbus 2002].

The sequence of events for RTO and corresponding speeds begins with an event at  $V_{Event}$ , a time delay to recognize the event during which the vehicle keeps accelerating to  $V_1$ , and an additional time delay after recognizing the event before brakes are applied  $V_{Brake}$ . The whole time delay between  $V_{Event}$  and  $V_{Brake}$  is of particular interest in pilot and vehicle response considerations. Some authors delineate  $V_{Event}$ ,  $V_1$ ,  $V_{Brake}$  as different speeds with a certain time delay between them, while others ignore the time delay for simplicity and only consider  $V_1$  as the decision speed [Anderson 1998].

FLOPS detailed take-off and landing module is used to obtain the BFL and decision speed details for the RTC, HWB, MFN, and BXW aircraft. FLOPS reports out all the three speeds  $V_{Event}$ ,  $V_1$ ,  $V_{Brake}$ . The decision speed  $V_1$  is that attained one second after the event ( $V_{Event}$ ). The speed at which the brakes are applied,  $V_{Brake}$ , has 2 second time lapse from decision speed. Results obtained from FLOPS output for and presented here focus on  $V_1$ .

Takeoff distance versus velocity plots for the T&W, HWB, BXW, and MFN are show in Figure 34, Figure 35 and Figure 36, and Figure 37 respectively. Each plot includes data series for all engine takeoff, one engine out climb, and one engine rejected take off with full stop,. In addition, the plots also indicate  $V_{Crit}$  and  $V_{Brake}$  . Results are further summarized and tabulated in Table 8 for comparison.

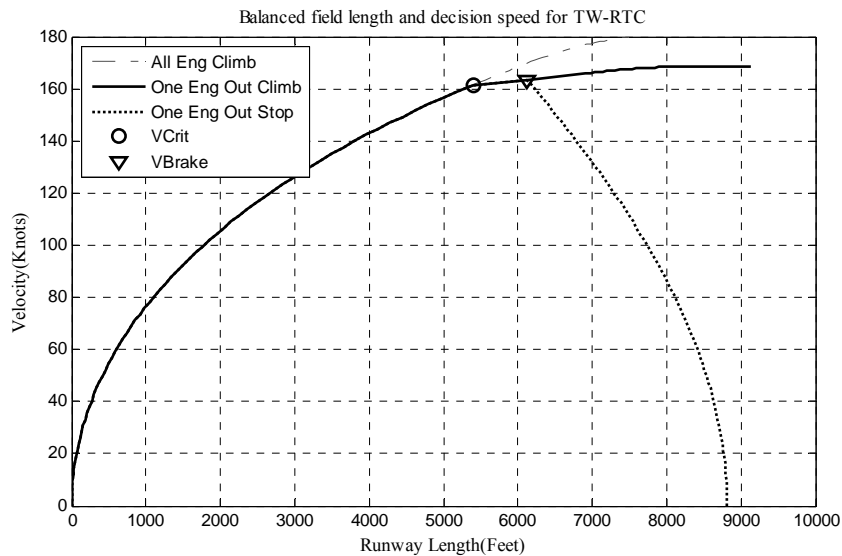
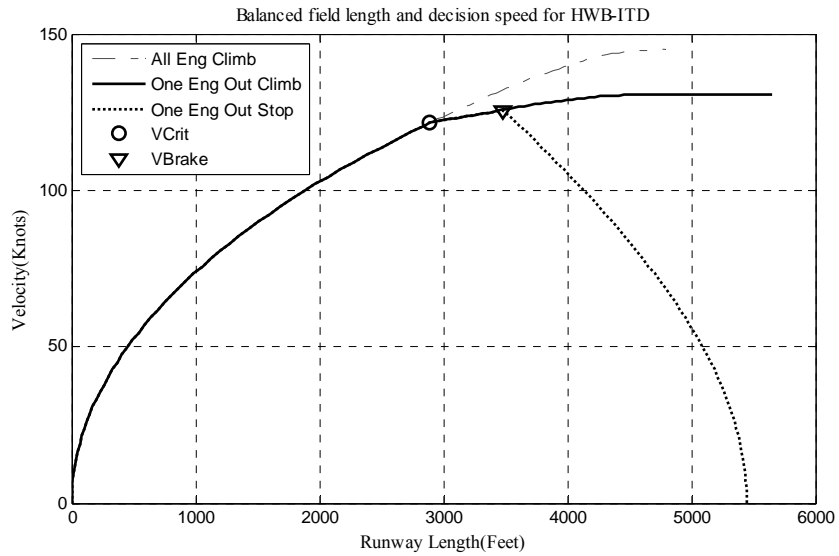
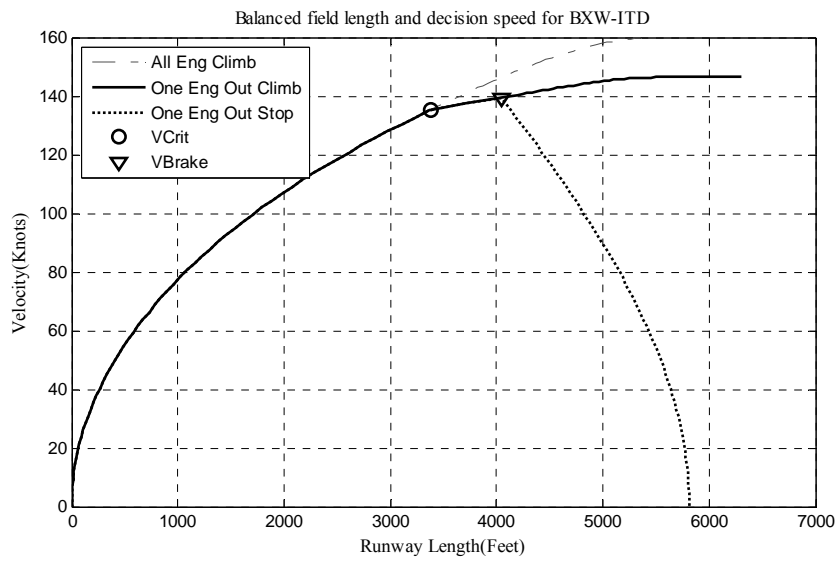


Figure 34 Balanced Field Length and Decision Speed for TRC T&W



**Figure 35 Balanced Field Length and Decision Speed for ITD HWB**



**Figure 36 Balanced Field Length and Decision Speed for ITD BXW**

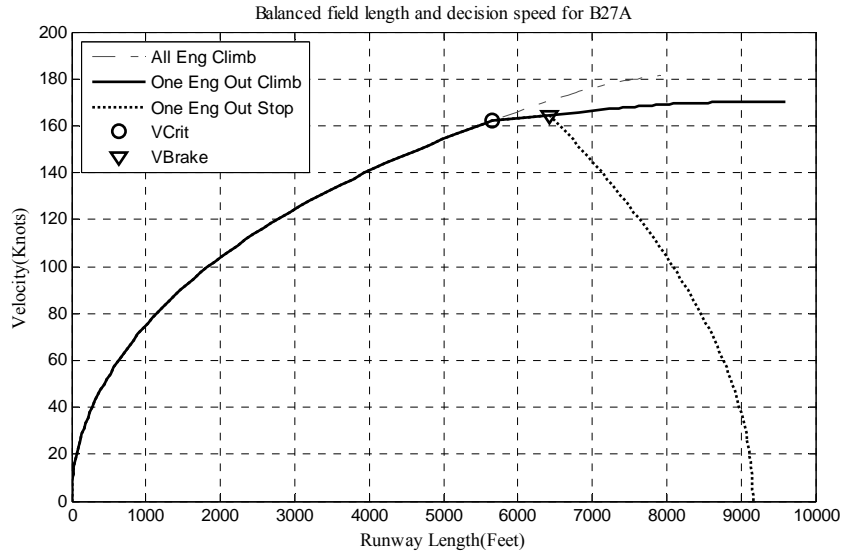


Figure 37 Balanced Field Length and Decision Speed for ITD MFN

Table 8 Balanced Field Length and Decision Speed Comparison

	ITD HWB	ITD BXW	ITD MFN	RTC TW
Vcrit (kts)	121.46	135.41	162.12	160.94
Vcrit Dist (ft)	2888	3384	5645	5344
Vbreak (kts)	125.66	139.52	164.66	163.5
Vbreak Dist (ft)	3482	4045	6431	6124
All Eng TOFL (ft)	4791	5368	7914	7480
One Eng Out TOFL (ft)	5646	6300	9595	9123
One Eng Out RTO (ft)	5446	5812	9159	8813
CL_Max	0.99	1.40	1.80	1.80
W/S_TO (lb/ft^2)	52	101	136	133
FAR Takeoff field length (ft)	5646	6300.08	9595.66	9123.19

It can be observed that the BFL requirement on the HWB is lesser than that of the TW, enhancing its operational compatibility and leaving a better safety margin on the runways which are already suitable for TW. It is of particular note that BXW accelerate stop distance is much smaller than that of the other two vehicles, however the one engine out

climb segment to clear the 35 feet obstacle made the runway requirement much closer to that of current T&W. However, as the BFL assumes the field length based on decision speed, any aborted takeoffs exceeding the calculated  $V_1$  due to human factors or vehicle characteristics pose a risk of runway overruns/ collisions with airport constructions/ accidents due to inadequate runway.

### **3. W, T, $\rho$ , runway slope, runway conditions**

Some of the design factors that affect BFL are the mass of the aircraft, engine thrust, density altitude, aircraft configuration, runway slope, runway wind component, and runway conditions which are not explored in detail here but are some of the vehicle level attributes that define the BFL requirements.

## **14. Climb**

### **1. Wake Vortex Hazard**

Wake vortex encounters are a significant hazard for aircraft in flight. Proper in-trail separation is the primary means for mitigating this hazard. In-trail traffic separation regulations/standards are dictated in part by wake vortex as a significant contributing factor, particularly for terminal area operations. In-trail separation is defined in nautical miles according to the weight class of the leading and trailing aircraft. In general, the wake hazard for a trailing aircraft is proportional with the intensity of the wake generated by the leading. Vortex intensity is driven by the total lift and lift distribution, which in turn are associated with aircraft weight, speed, and aerodynamic characteristics governed by geometry. Unconventional configurations are therefore of especial interest. In addition, NextGen will make use of precise navigation and surveillance technologies such as RNAV, RNP, ADS-B to safely enable operations with reduced traffic separation.

The wake vortex analysis here reported makes use of available design data at the conceptual phase as well as documented analytical models to ascertain potential wake vortex hazards. A full scale wake hazard quantification model usually consists of the following elements

#### **1. Wake vortex generation, evolution and decay**

2. Wake encounter
3. Flight path evolution and wake encounter probability
4. Safety and risk quantification

For the current process, a simple first order wake generation and wake encounter model are implemented. The model does not consider the probability of encounter, but rather quantifies the effect on encountering aircraft as a case when it passes through the center of the core of the vortex. Rolling moment coefficient is considered as the safety metric for wake encounter effect quantification. Vortex interactions, vortex decay, and flight path are not modeled but can be a part of detailed operational models where the separation standards are either quantified or analyzed.

## 2. Wake generation

The origin of the counter rotating wing tip vortices is a direct and automatic consequence of the generation of lift by a wing. Wake vortices generated by a lifting wing and shed near the tip as shown in Figure 38.

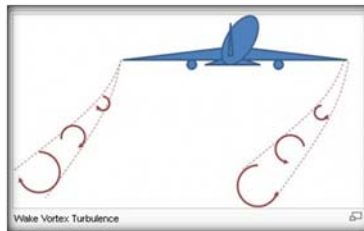


Figure 38 Wake Vortex [Skybrary 2015]

Some of the major contributing vehicle-level contributing factors are aircraft weight, shape of the wing, flap settings (aircraft configuration), aircraft speed, proximity to the ground, wind velocity, and turbulence other than that of the vortex.

Wake effects can be quantified by using a detailed, high fidelity Computational Fluid Dynamics (CFD) model when the full design and operational details of the aircraft are known. Alternatively several first-order analytical vortex models (low order algebraic) are available. They include the Rankine Vortex, Lamb-Oseen Vortex, Burnham-Hallock Model, Winckelmans Model, Jacquin VM2 Vortex, and Double

Gaussian Vortex [Liu 2007]. Of all these models the literature most often quotes Burnhan-Hallock [Ghigliazzam 2007], used for the present analysis.

### 3. Vortex Strength $\Gamma$ , Tangential Velocity Induced $V_\theta$

Important parameters that are often used are considered from [Liu 2007] and are depicted in Figure 39. The following parameters are used for computing wake generation.

1. Circulation strength ( $\Gamma$ )
2. Tangential velocity induced by vortex tube ( $V_\theta$ )

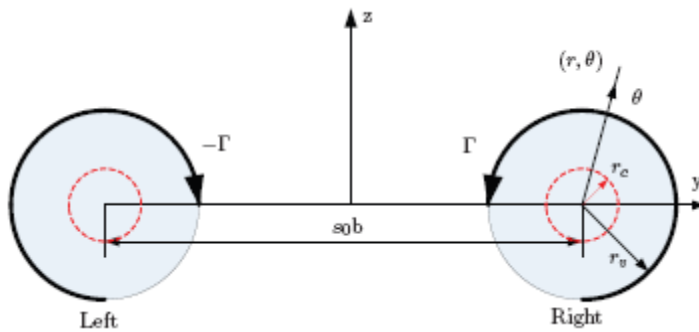


Figure 39 Vortex pair with vorticity radius  $r_v$ , vortex core radius  $r_c$ , lateral distance  $sob$  [Liu 2007]

Using the Hallock Burnham model, vortex strength is found from the Equation 1 and tangential velocity from Equation 2.

$$\Gamma = \Gamma_0 \frac{r^2}{r^2 + r_c^2}$$

Equation 1 Vortex Strength

$$v_\theta = \left( \frac{\Gamma_0}{2\pi} \right) \frac{r}{r^2 + r_c^2}$$

Equation 2 Tangential Velocity

Where, the initial circulation  $\Gamma_0$  is given by Kutta – Joukowski theorem by the Equation 3 assuming an elliptical lift distribution ,

$$\Gamma_0 = \frac{4W}{\pi\rho Vb}$$

Equation 3 Initial Strength

and the vortex strength along the downstream is a result of core radius  $r_c$  being implicitly dependent on the downstream distance( $x$ ) from the generating wing as shown in Equation 4

$$r_c = 0.0125 \sqrt{\Gamma_0 x / V}$$

Equation 4 Core Radius

Parameters in the above equations are

$\Gamma$  = Circulation strength

$\Gamma_0$  = Initial circulation strength

$r$  = radial distance to the center of tube

$r_c$  = core radius, radius at which the tangential velocity reaches the maximum

$V_\theta$  = Tangential velocity

$W$  = Weight of the aircraft

$V$  = Velocity of the aircraft

$\rho$  = density of the air

$b$  = span of the aircraft

$x$  = downstream distance

It can be observed that the initial circulation  $\Gamma_0$ , and thus the circulation  $\Gamma$ , at a given  $r$  depend on the span loading ( $W/b$ ) and Velocity  $V$  of the given aircraft. Since the weight of the aircraft is heavier, and the speed is slower, at take-off/ initial climb segment, this point is considered as the critical point for vortex strength evaluation. Hence, wake analysis is considered only in the takeoff/climb segment.

$W_{T0}, b, \rho, V$

Vehicle attributes parameters required to calculate the wake generation parameters during the climb segment are shown in Table 9.

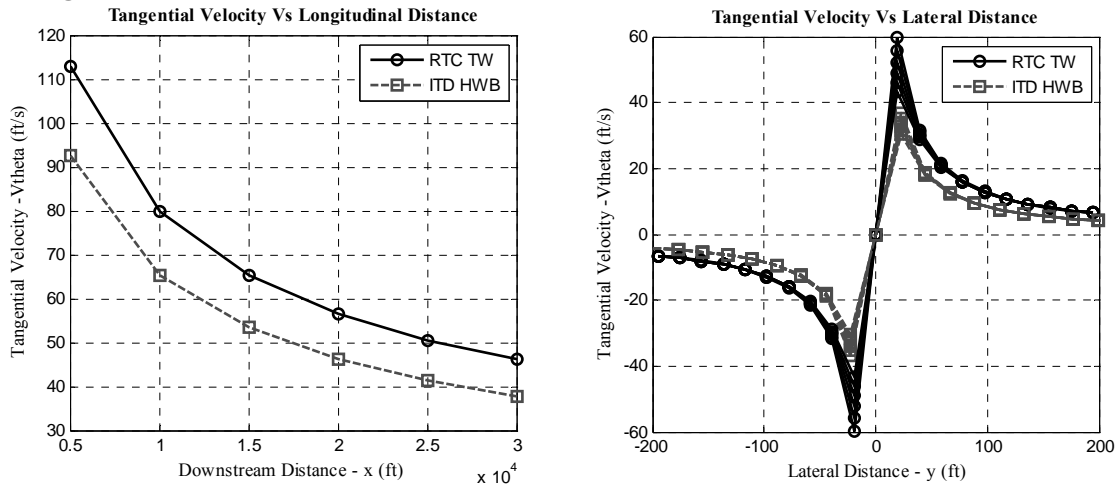
Table 9 Aircraft Properties for Wake proxy estimation

Parameters	RTC TW	ITD HWB	ITD MFN
Take Off Weight (lbs)	553,976	422,174	447,238
Span(ft)	194.82	221.57	181.82



The wake generation safety proxies, maximum tangential velocity along the downstream distance and lateral distance are evaluated using the Hallock Burnham model for the new vehicles along with that of the reference vehicle. Conditions at start of climb are assumed, namely Mach 0.3 after clearing 35 ft at takeoff, corresponding to 198.4 kts. Estimation for the BXW concept is not included because its lift distributions is not well understood and generally expected to be non-elliptical. More generally, the wake vortex phenomena of the BXW configuration is not sufficiently understood at this time and is therefore not included in the analysis with the Hallock Burnham model.

Figure 40 and Figure 41 respectively depict the tangential vortex core velocity as a function of downstream distance, and the tangential velocity as a function of lateral distance, for the HWB and MFN compared to those for the RTC. Results indicate that both the MFN and the HWB generate milder wake phenomena, with the HWB providing the greatest benefits.



**Figure 40** Wake vortex characteristic velocities for the HWB compared to T&W

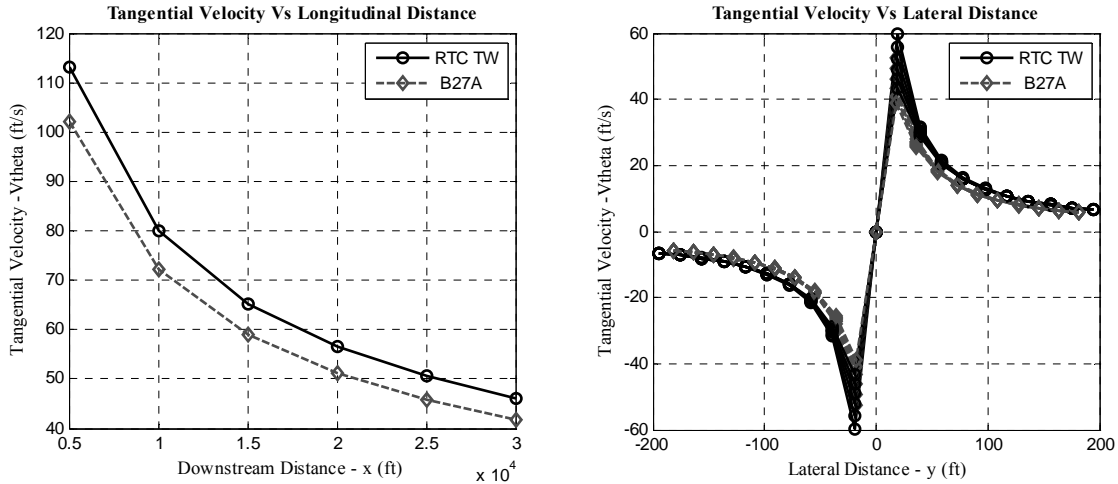


Figure 41 Wake vortex characteristic velocities for the MFN compared to T&W

Multiple lines on the tangential velocity plot for a given vehicle correspond to incremental downstream distances 5000 feet to 30000 feet with increments of 5000 feet. Higher values correspond to a closer distance downstream from the aircraft.

The values from the Figure 40 and Figure 41 show that the HWB generates the weakest wake both in lateral and longitudinal directions. Hence it may permit decreased separation when the HWB is the leading aircraft.

#### 4. Wake Encounter

Aircraft encountering the wake at different locations in the wake is shown in Figure 42. The effect of wake on the encountering aircraft depends on the location at which it encounters the wake, and the direction in which the aircraft passes through the wake. Out of all the effects, the hazard due to the wake is higher when the aircraft is passing through the center of the vortex core [Liu 2007], which induces roll. This hazard is quantified using induced roll moments, which is the safety proxy for wake encounter. The consequence of the risk is higher when the aircraft is especially closer to the ground. This concept is illustrated in Figure 42.

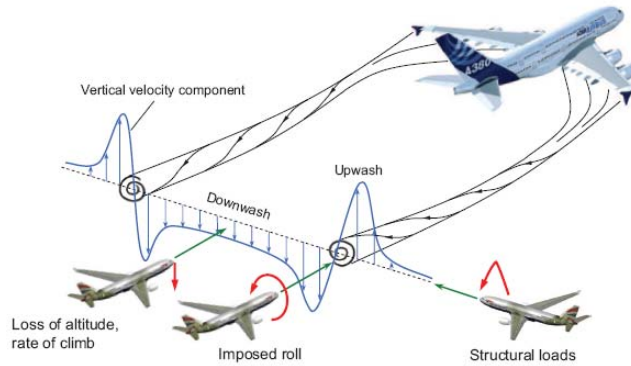


Figure 42 Aircraft encountering the wake vortex [Liu 2007]

Some of the other safety proxies which can be used to describe the response due to wake encounter effect are bank angle, roll moment, roll rate, acceleration, pitch angle, pitch rate, and ratio of roll control to the vortex induced roll. Induced roll moment is quantified at five different locations corresponding to downstream distances of 5000 to 30000 feet in the increments of 5000 feet behind the generated aircraft.

During the wake encounter scenario, it is assumed that the Tube and Wing (TW) aircraft is the wake generator, because wake generated by (TW) has higher tangential velocity. Induced rolling moment, which defines the safety proxy for wake encounter effect, is calculated for both BXW and HWB.

#### 5. Maximum Roll Induced Coefficient ( $C_l$ )

Maximum roll induced coefficient is evaluated using the moment caused by the change in the lift force due to the tangential velocity vector in the lateral direction [Economon 2008] as shown by Equation 5.

$$C_l = \frac{1}{Q S b_p} 2 \int_0^{b/2} y C_{l_\alpha} \frac{V_\theta(y)}{V_\infty} Q c(y) dy .$$

Equation 5 Roll Moment Coefficient

where

$C_l$  = Coefficient of roll

$Q$  = Dynamic pressure

$S$  = Vortex strength

$b_p$  = Span of the wake penetrating aircraft  
 $V_\infty$  = Speed of the penetrating aircraft  
 $V_\theta$  = Tangential vortex velocity  
 $C_{L\alpha}$  = Wing lift curve slope of penetrating aircraft  
 $C$  = Chord length of the penetrating aircraft  
 $y$  = Location on wing relative to vortex location

6.  $\Gamma, b_p, V_\infty, a, C_{L\alpha}$

Simplifying the above equation for a rectangular wing as a first order approximation [Economon 2008] the expression is thus given in Equation 6

$$C_l = \frac{C_{L\alpha} \Gamma}{6b_p V_\infty \pi} \left( 3 - 4 \frac{a}{b_p} \right),$$

Equation 6 Roll Moment Coefficient (Rect. Wing)

where

$C_l$  = Coefficient of roll  
 $C_{L\alpha}$  = Wing lift curve slope  
 $\Gamma$  = vortex strength  
 $b_p$  = Span of the wake penetrating aircraft  
 $V_\infty$  = speed of the penetrating aircraft  
 $a$  = vortex radius =  $r_c$

This equation, though not accurate to use for swept wings, is used for the first iteration, to evaluate the roll moment coefficient using the aircraft's parameters, i.e., vehicle attributes.

For swept wing a numerical integration method is necessary to compute induced rolling moment for wing sections as a function of section chord. Using Equation 7 the roll moment coefficient can be evaluated when the wing penetrates anywhere in the wake apart from the core of the vortex using numerical methods.

$$C_l = \frac{C_{L\alpha} \Delta y}{S b_p V_\infty} \sum_{i=1}^n V_{\theta_i} c_i y_i$$

Equation 7 Roll Moment Coefficient (Numerical Method)

where

$C_{L\alpha}$  = Wing lift curve slope

$b_p$  = Span of the wake penetrating aircraft

$V_\infty$  = Speed of the penetrating aircraft

$S$  = Vortex strength  $y$  = Location on wing relative to vortex

location

$V_{\theta i}$  = Tangential vortex velocity at location  $i$

$\Delta y$  = Number of steps (segments)

$C_i$  = Chord length at location  $i$

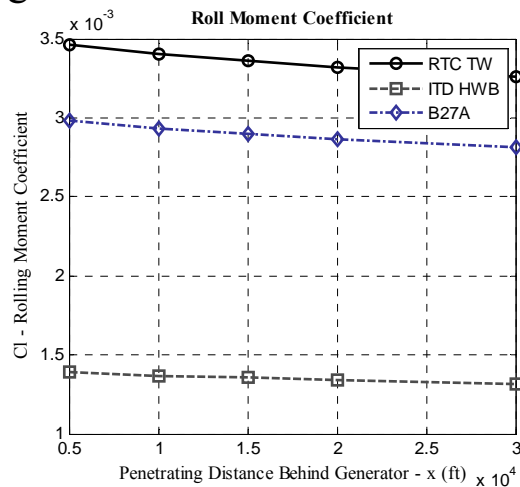


Figure 43 Rolling Moment Coefficient at different downstream distances

The points in Figure 43 correspond to downstream distances of 5000 to 30000 feet in increments of 5000 feet behind the wake generating aircraft. Results suggest that the HWB is less susceptible to induced rolling moments than the MFN and T&W respectively. However, it should be remembered that the approximation of rectangular wings is considered for the first iteration and hence these results may not be accurate. As before, the aerodynamic properties of the BXW concept are not sufficiently understood to allow for the evaluation of this proxy metric. Estimates are not included.

## 7. Stall

It is very important to consider the stall margin present/ available especially during landing and climb. Any gust perpendicular to the

aircraft flight path can increase the angle of attack and reduce the stall margin.

### 8. Stall Margin

Stall margin during gusts (gust perpendicular to flight path) is analyzed during climb phase. In the analysis below,  $\Delta\alpha$  is the increase in angle of attack due to gust,  $U$  is gust velocity and  $V$  is aircraft velocity considered in knots. These quantities are related as follows:

$$\tan(\Delta\alpha) = U/V$$

Equation 8 Stall Margin equation

The liftoff velocity and angle of attack for nominal conditions are used as a reference, and the gust value is solved for so that the additional induced angle of attack results in the onset of stall. The gust value identified is interpreted as the gust margin for takeoff conditions of interest, namely all engine operations and one engine out. The gust margin estimates and related parameters are summarized in Table 10. Analysis is not conducted for the BXW due to low confidence in the low-speed aerodynamic properties estimated or assumed for that configuration.

Table 10 Gust margin at Takeoff and related parameters

	Parameter	RTC T&W	ITD HWB	ITD MFN
All Engines	$V_{TO}$ [kts]	176	144	177
	$\alpha_{TO}$ [deg]	8.6	17.3	8.6
	$C_{L,TO}$	1.39	0.9	1.39
	$C_{L,Max,TO}$	1.8	1.0	1.8
	Gust Margin [kts]	19.7	5.6	19.7
One Engine Out	$V_{TO}$ [kts]	168	130	170
	$\alpha_{TO}$ [deg]	8.7	17.2	8.6
	$C_{L,TO}$	1.39	0.9	1.39
	$C_{L,Max,TO}$	1.8	1.0	1.8
	Gust Margin [kts]	18.8	5.2	18.9

It can be seen from the above analysis, out of all three aircraft, that the HWB has considerably less gust margin and hence is more susceptible to gust-induced stall when compared to other concepts.

## 9. Wind Shear Hazard

Wind shear hazard is considered in this section. Some basic definitions for angles and references are presented before analyzing the wind shear hazard.

Angle definitions during climb with reference to Figure 44:

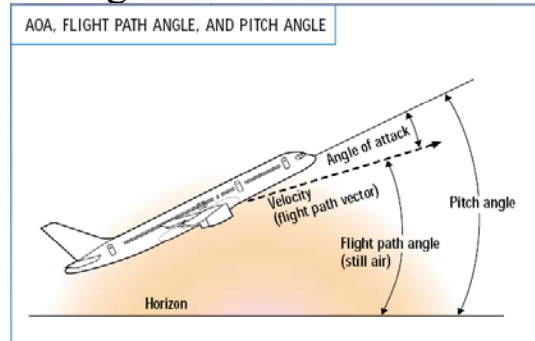


Figure 44 Pitch Attitude [Boeing 2015]

1. Angle of Attack (AoA) is the angle between the relative wind (dotted line direction) and reference line on the aircraft or wing
2. Flight path angle is the angle between the flight path vector and horizon also called as climb angle during climb
3. Pitch angle/ Pitch attitude is the sum of AoA and flight path angle

The four conditions that generally describe aircraft upset during flight are noted from reference [Boeing 2015a]. These are shown in Figure 45. The pitch attitude is further explored during the wind shear effects on the aircraft.

1. Pitch attitude more than 25 degree nose up
2. Pitch attitude more than 10 degree nose down
3. Bank Angle more than 45 degrees
4. Flights within these parameters at airspeeds inappropriate for the conditions

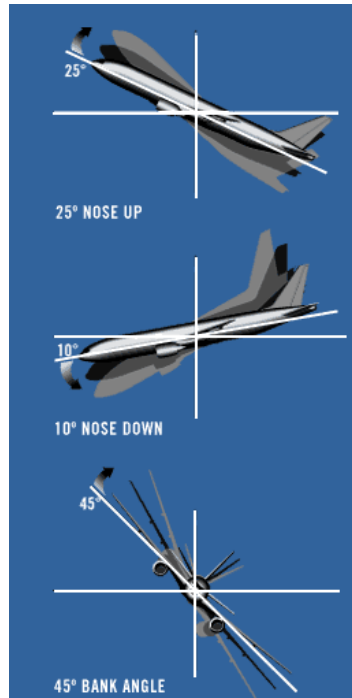


Figure 45 Aircraft Upset Conditions

Strong winds can quickly upset the aircraft. Wind component can be head wind/ tail wind, downdraft/updraft or a combination of any of these. Wind gusts affect the rate of climb / flight path angle or both depending on the wind direction which they are experiencing.

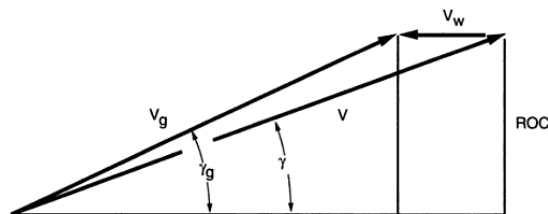


Figure 46 Effect on Flight Path Angle and ROC due to head wind [Lowry 1999]

Head Wind Case: Consider  $V$  as the speed of the aircraft, and  $\gamma$  the flight path angle in the absence of a wind component. Under the influence of head wind  $V_w$ , the new velocity is the vector addition of  $V$  and  $V_w$  (the wind velocity). As it can be observed the effect is an increase in flight path angle and a decrease in the flight velocity. Rate of climb will not change as shown in Figure 46. Ground distance required to clear the obstacle is reduced in case of a head wind while a tail wind



increases the required ground distance by reducing the flight path angle. Hence, the tail wind case is more critical than the headwind.

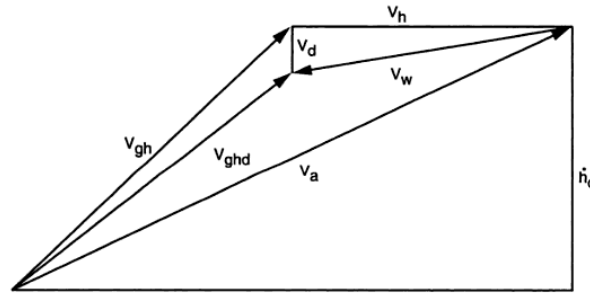


Figure 47 Effect on Flight Path Angle and ROC due to head wind and down draft [Lowry 1999]

Head Wind and Down Draft: Consider  $V$  as the speed of the aircraft, and  $\gamma$  the flight path angle in the absence of a wind component. Under the influence of head wind  $V_h$ , and down draft  $V_d$  the aircraft's new velocity is the vector resultant of  $V$  and  $V_w$ , where  $V_w$  is resultant of  $V_h$  and  $V_d$ . As can be observed the effect shown graphically in Figure 47 is to increase flight path angle and decrease flight velocity. Rate of climb also decreases as seen in the Figure 47. However, it is obvious that these effects are very dependent on the magnitude of the vectors and cannot be generalized. It can also be seen that the ground distance is also affected in all the cases. The tail wind and updraft effects are exactly opposite to that of the headwind and downdraft.

To properly define the velocity vectors it is necessary to pick a reference point and reference system considered is the earth reference system (fixed to the ground).

#### *Wind Shears:*

Adverse weather conditions, strong winds, tail winds, wind shear are involved in more than 30 percent of approach and landing accidents [Airbus 2015]. Wind shear is defined as sudden change of wind velocity and/ or direction. Wind shear conditions exist in weather conditions such as jet streams, mountain waves, frontal surfaces, thunder storms, convective clouds and microbursts.

Microbursts combine two distinctive threats

1. Downburst, which can have strong downdraft of 6000fpm
2. Outburst, wind component shift from headwind to tailwind, reaching up to 45knots.

These magnitudes of wind shear components are considered for the analysis.

Wind shear effect on the aircraft is considered from the reference [Airbus 2015]. The wind shear can be head wind, down draft and tail wind depending on the aircraft orientation. The following effects are produced on an aircraft when it counters the wind shear.

1. Head gust instantaneously increases the aircraft speed and make it fly above the intended flight path and / or accelerate
2. A downdraft changes the flight path since it makes aircraft sink
3. Tail wind instantaneously decrease the aircraft speed, makes it fly below the intended path, and decelerate

#### Climb Analysis Equations

Flight path angle and rate of climb are calculated using Equation 9 and Equation 10.

$$\sin \gamma = \frac{T - D}{W}$$

Equation 9 Climb Angle

$$(R/C) = V \sin \theta$$

Equation 10 Rate of Climb

Below given scenarios are analyzed

1. Microbursts in front of aircraft(Head wind)
2. Microbursts behind the aircraft(Tailwind)
3. Aircraft through Microbursts (Downdraft)

Thrust, Drag, Weight are chosen from the FLOPS performance output files for a climb segment. Values for climb segment are picked where the Thrust has minimum value, and Drag is maximum.

#### 10. Climb Angle, Climb Speed and Climb Rate

Climb angle, Climb speed, and Climb rate metrics are considered as safety proxies to study the effect of the wind shear.

## 11. Altitude, Speed (V), Thrust (T<sub>av</sub>), Drag, Weight

Altitude, Speed, Thrust, Drag, and Weight are the vehicle level properties required to analyze the wind shear effect.

The results are summarized in Table 11 for all vehicles and all scenarios of interest described above. In each case nominal conditions are shown to the left, and conditions with the microburst are shown on the right.

**Table 11 Effect of Microbursts on climb-out performance**

TAKEOFF - Front Microburst								
Start of Climb M=0.3, V=198 kts, Microburst ΔV= 60kts								
	TW		HWB		BXW		B27A	
T[lbs]	124,818	124,818	85,930	85,930	104,133	104,133	94,659	94,659
D[lb]	40,532	40,532	16,896	16,896	18,091	18,091	28,666	28,666
W[lbs]	552,101	552,101	421,046	421,046	463,720	463,720	445,936	445,936
Climb angle[deg]	8.8	12.6	9.4	13.5	10.7	15.3	8.5	12.2
Climb speed[ft/s]	335	235	335	236	335	236	335	235
Climb Rate[fpm]	3068	3068	3295	3295	3729	3729	2974	2974
TAKEOFF - Behind Microburst								
Start of Climb M=0.3, V=198 kts, Microburst ΔV= 60kts								
	TW		HWB		BXW		B27A	
T[lbs]	124,818	124,818	85,930	85,930	104,133	104,133	94,659	94,659
D[lb]	40,532	40,532	16,896	16,896	18,091	18,091	28,666	28,666
W[lbs]	552,101	552,101	421,046	421,046	463,720	463,720	445,936	445,936
Climb angle[deg]	8.8	6.7	9.4	7.3	10.7	8.2	8.5	6.5
Climb speed[ft/s]	335	435	335	435	335	435	335	435
Climb Rate[fpm]	3068	3068	3295	3295	3729	3729	2974	2974
TAKEOFF - Down Microburst								
Start of Climb M=0.3, V=198 kts, Microburst ΔU= 60kts								
	TW		HWB		BXW		B27A	
T[lbs]	124,818	124,818	85,930	85,930	104,133	104,133	94,659	94,659
D[lb]	40,532	40,532	16,896	16,896	18,091	18,091	28,666	28,666
W[lbs]	552,101	552,101	421,046	421,046	463,720	463,720	445,936	445,936
Climb angle[deg]	8.8	-8.6	9.4	-8.0	10.7	-6.8	8.5	-8.9
Climb speed[ft/s]	334.93	334.78	334.93	333.63	334.93	331.43	334.93	335.25
Climb Rate[fpm]	3068	-3008	3295	-2781	3729	-2347	2974	-3102

## 12. Loss of Separation

With the NextGen aiming to support increasing volumes of air traffic in and out of airports differential vehicle performance plays a huge role in all the mission segments starting from take-off to landing. Significant differences cause difficulties in planning and operations at the airport.

### 13. Separation in terms of $T_{\text{delay}}$

Loss of separation between two aircrafts is quantified using  $T_{\text{delay}}$ , the time separation between the two aircrafts that need to start at a given airport on a given runway.  $T_{\text{delay}}$  required is calculated by separation standards requirements consideration.

Take-off and landing are the bottle necks for the air traffic as these are constrained by the aircraft performance such as climb rates, and wake vortex separation standards based on aircraft weight category. NextGen operational environment, aircrafts will be operating on ASD-B technology, with ADSB-In and ADS-B Out where the surrounding aircrafts can sense the position and velocity of the nearby aircrafts within the range of their ASD-B units. There is a need for adequate separation assurance as any of the technologies, if failed at any stage of the mission, may lead to a collision. The current separation standards are considered for the simple analysis of separation requirements.

FLOPS data is considered for the mission profile. The velocity and position for each segment, in both vertical and horizontal directions is considered. Since the data is spaced at non uniform time intervals with in FLOPS, a regression equation, of polynomial type for each mission segment is generated and used further in a MATLAB routine that simulates the flight path. Two vehicles chosen are HWB, the new vehicle configuration, and the TW-50A which has the least time required to reach its cruise segment when compared with other RTC vehicles of TW fleet (50,50-advanced, 100,150,210,300,400 passenger aircrafts).

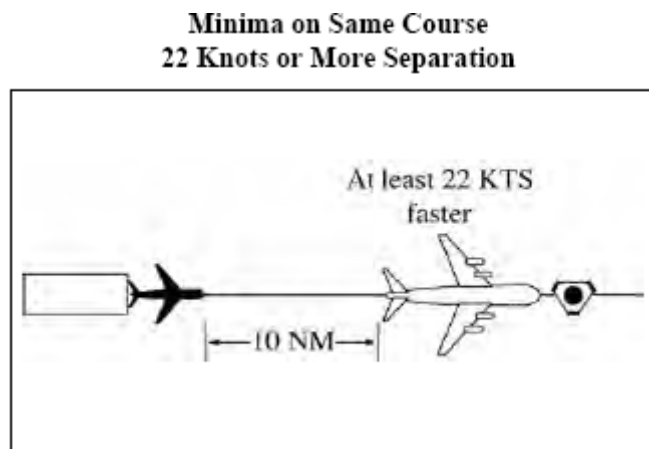
Altitude and Range are regressed against the time from the data considered from FLOPS. The time of each mission segment and the interval at which the simulation is needed is the input to the MATLAB routine. For the simulations of this report, a 1 minute time scale is considered. A scenario where the two aircrafts depart from the same runway is considered.

Separation requirements are based on section 6-4-2 of reference [2012c] for longitudinal direction. The reference requirements for the Minima on Same, Converging or Crossing courses from Non-Radar

section are shown in Figure 48 and are explained in the immediate following paragraph.

“When the leading aircraft maintains a speed at least 22 knots faster than the following aircraft –

*10 miles* between DME equipped aircraft; RNAV equipped aircraft using ATD; and between DME and ATD aircraft provided the DME aircraft is either 10,000 feet or below or outside of 10 miles from the DME NAVAID; or *5 minutes* between other aircraft if, in either case, one of the following conditions exists: 1. A departing aircraft follows a preceding aircraft which has taken off from the same or an adjacent airport.” (See Figure 48)”.



**Figure 48 Separation Requirements**

The HWB cruises at 481.8 knots while the TW-50 Advanced vehicle cruises at 458.8 knots, making the HWB cruise at 23 knots higher than the TW-50. Hence 10NM separation is required as shown in Figure 48.

#### **14. Mission Segment Details from FLOPS**

FLOPS mission segment data is considered for the climb segments. The T&W Regional Jet developed in this study has the least time to climb and is utilized as the most critical condition for a trailing aircraft. The Regional jet is a 50 passenger nominal aircraft denoted as TW50A. The mission segment data of the TW50A and the advance concepts here assessed can be compared to determine the time to loss of separation for consecutive takeoffs where the TW50A is the trailing aircraft, assuming

some delay time. The climb-out profile for the TW50A and the three unconventional configurations of interest are graphically depicted in Figure 48

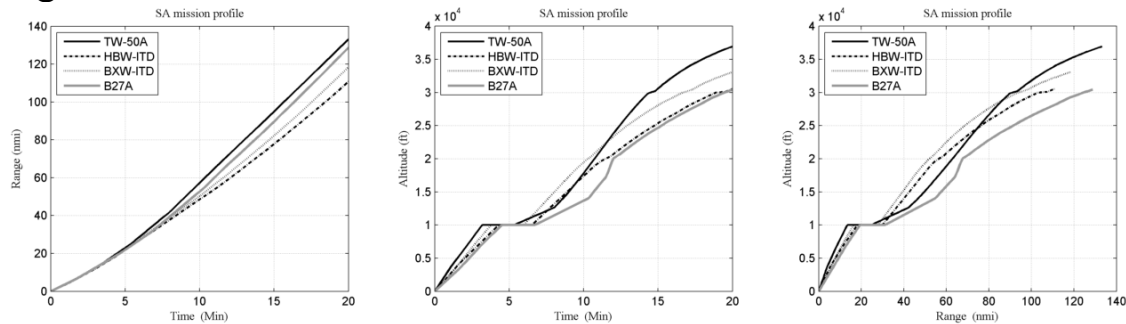


Figure 49 Climbout profile for advanced Regional Jet and advanced concepts

The horizontal and vertical separation between the leading advanced concept and the trailing TW50A is depicted as a time-trace of data points, indicated by a progression from dark grey to white, for the HWB, BXW, and MFN in Figure 50, Figure 51, and Figure 52 respectively. In each case we consider time delays of 2, 5, and 7 minutes. The red box at the bottom left of each plot indicates the boundary for loss of separation.

As can be noted the HWB and BXW observe potential loss of separation with a 2 minute window between consecutive takeoffs, readily explained by their more modest velocity and altitude profile for climb out compared to other vehicles. The MFN features climb out more commensurate with other T&W configurations and therefore does not feature loss of separation potential.

The potential for loss of separation here noted assumes that vehicles fly exactly the same straight-line ground track and are not subject to any kind of positive traffic control. In reality these assumptions are extremely rare, and difference in departure tracks as well as enactment of traffic control actions would offer separation assurance measures.

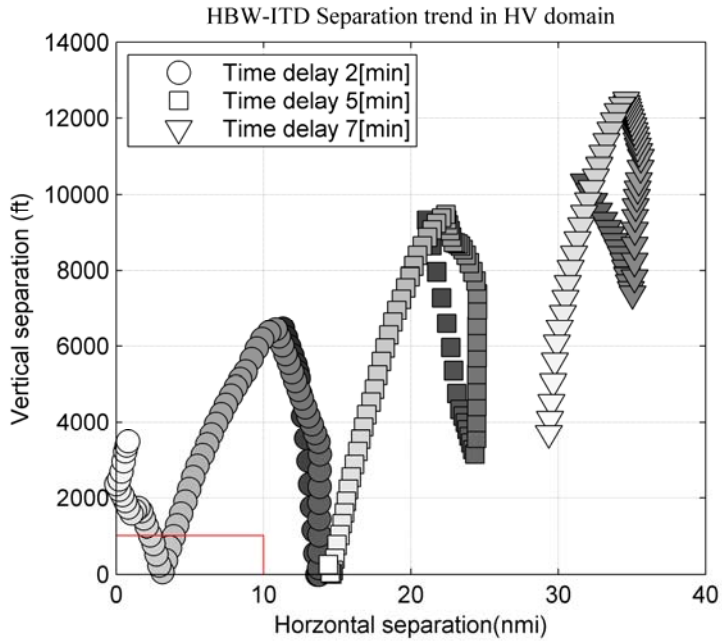


Figure 50 Loss of Separation for HWB leading TW50A

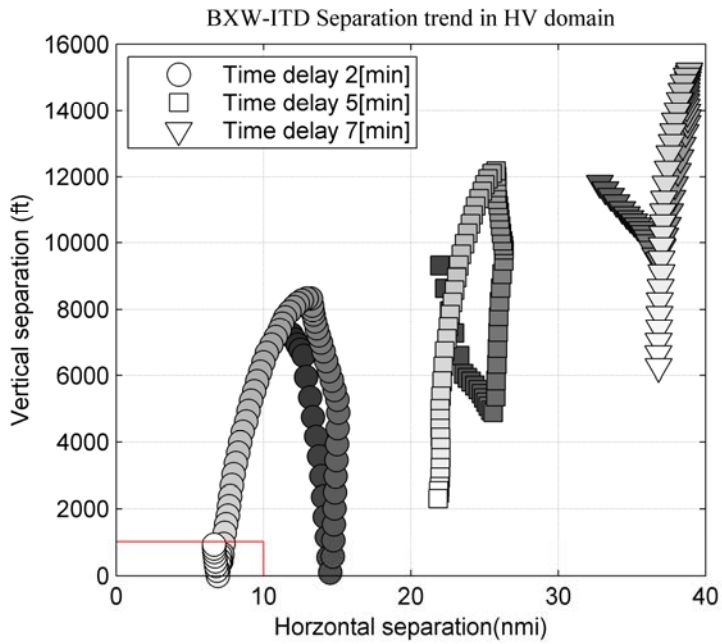


Figure 51 Loss of Separation for BXW leading TW50A

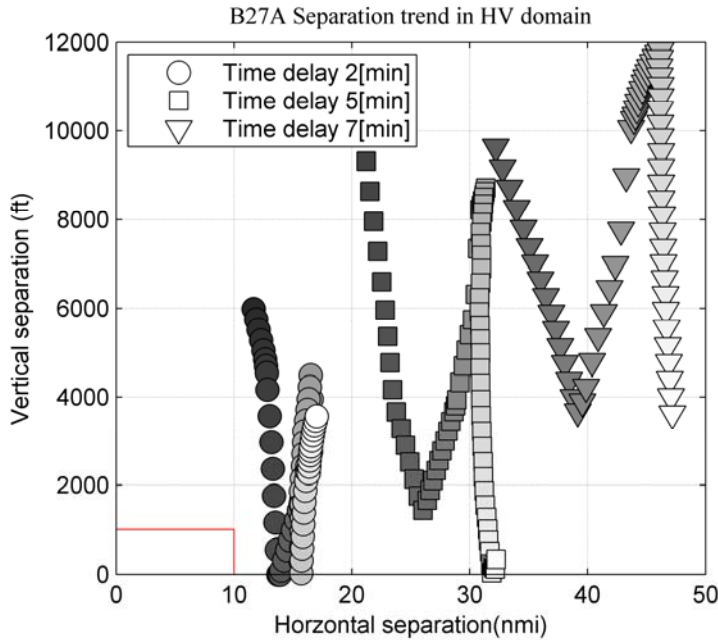


Figure 52 Loss of Separation for MFNleading TW50A

## 15. Cruise

### 1. Loss of Separation due to High/Low Cruise Rates

Hazard due to loss of separation that is possible due to differential cruise performance is considered. In order to quantify loss of separation at NAS level, vehicle level cruise parameters are to be considered in the fleet analysis of airspace.

### 2. Cruise Speed

Table 12 Cruise Speed Comparison

Parameter	ITD HWB	ITD BXW	RTC TW
Cruise Speed (Knots)	481.80	481.80	481.80
Cruise Mach	0.84	0.84	0.84
Cruise altitude (Feet)	37000-42000	39000, 41407- 43000 (Cruise and Cruise Climb)	35000 and 39000
	Cruise Climb		Cruise

Cruise speeds for 300 passengers HWB, BXW and TW are same, though the cruise altitudes are different. If there is adequate horizontal separation between the two at the start of cruise phase, it would remain



so as long as no weather related issues/ course diversions occur / deviations from their cruise conditions occur.

## 16. Descent and Approach

NextGen procedures such as Optimum Profile Descent (OPD), which includes Continuous Descent Arrivals (CDA), Tailored Arrivals (TA), will be implemented for minimizing fuel consumption, noise and emissions. These procedures typically are supposed to have descent at higher glide slopes as much as 6 degrees. In the following section, the glide slope angles and Vapp are analyzed for meeting stabilized approach criterion and for a successful go-around analysis.

Decision Height, Sink Rate, Vapp, flight path angle, go-around analysis

Most of the accidents occur during takeoff and landing phase according to the accident statistics as shown in Figure 53. In this section, landing phase is analyzed for stabilized approach, in terms of aircraft imperative metrics such as Vapp, flight path angle, and sink rate to determine which of these parameter combinations make the approach deviate from the stabilized approach.

### Fatal Accidents and Onboard Fatalities by Phase of Flight Worldwide Commercial Jet Fleet – 2002 Through 2011

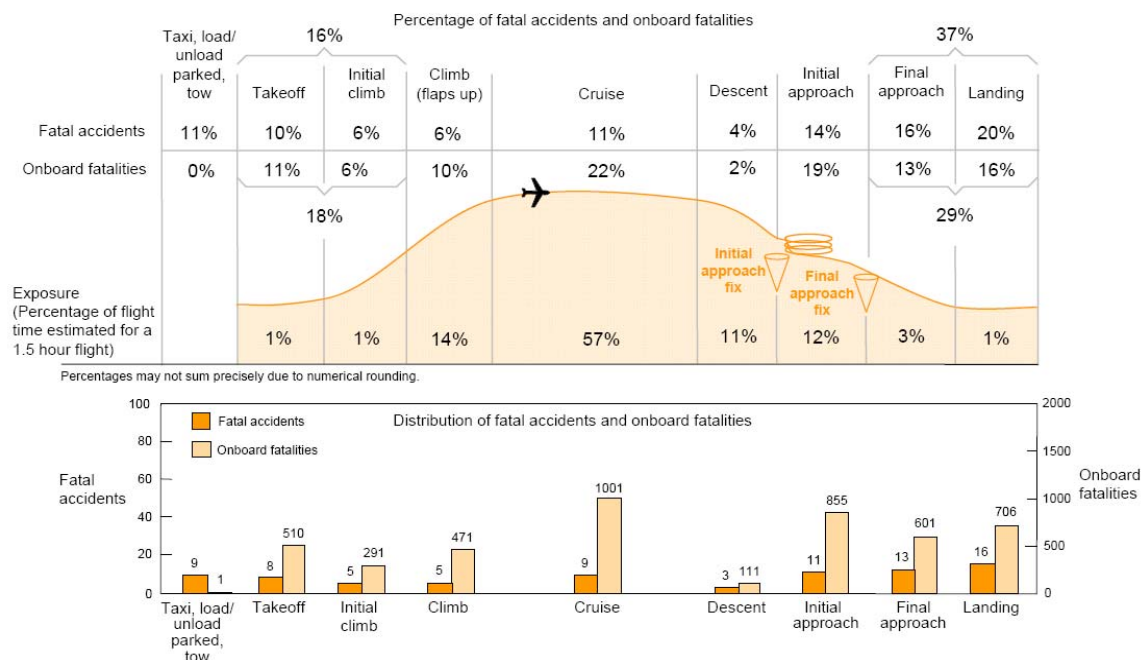


Figure 53 Distribution of Accidents according to Mission phase [Boeing 2011]

A stabilized approach is the one in which the pilot establishes and maintains a constant angle glide path towards a predetermined point on the landing runway [FAA 2015a]. The objective of a stabilized approach is to select appropriate touchdown point on the runway, and adjust the glide path so that the true aiming point and the desired touch down point basically coincide.

Requirements to achieve a stabilized approach are listed in [Airbus 2015a], some of them are listed below. Defining elements of a stabilized approach are,

1. Aircraft on correct lateral and vertical flight path
2. The thrust is stabilized; usually above idle, to maintain target approach speed along the desired final approach path
3. Aircraft in desired landing configuration
4. Stabilized heights (IMC – 1000ft and VMC – 500ft)

Some of the excessive flight parameter criteria which can make stabilized approach un-stabilized one are

1. Airspeed - 5 knots less than  $V_{app}$  or 10 knots greater than  $V_{app}$
2. Vertical speed (Sink Rate) greater than 1000ft/min
3. Bank Angle of greater than 7 degree
4. Pitch attitude deviations
5. Deviations from the path

Apart from the flight performance characteristics, some of the human factors such as pilot fatigue, late runway changes, in adequate use of automation, insufficient awareness of situation etc. also play a major role. For complete list of factors, refer [Airbus 2015a].

Some of the NextGen technologies such as RNAV, RNP, making the lateral and longitudinal flight path deviations very minimal, would aid in reducing the error due to pilot/ human factors. However, these new technologies shift the focus of safety concerns to completely new domains such as human-technology interaction, human-technology dependence.

Fuel reduction, noise reductions and emission reduction goals would mandate the steeper glide paths apart from the current 3 degree

glide slopes. Further in the report it would be shown that steeper glide slopes require slower  $V_{app}$  in order to have stabilized approaches. Safety analysis are considered based on the following three relations

1. Flight path angle and rate of sink
  2. Go-around capability
  3. Landing field length requirements
1. **Un-Stabilized Approach**
  2. **Flight path angle and rate of sink**

Approach angles up to  $3.5^\circ$  are considered routine; angles 3.5 to 4.5 degrees “are unlikely to produce any significant problems in normal operations.” It is internationally accepted that approach paths 4.5 degrees or greater constitute steep approaches. NextGen operational requirements for noise abatement, fuel savings make it necessary for future aircrafts to perform steeper approaches as close as 6 degrees, while some airports, due to their location necessitate the steeper approaches due to the surrounding obstacles/ building landscape. Some of the manufacturers are already considering these requirements in their design process [Stouffer 2013].

Speed and flight path control with increasing flight path become more demanding. Since the approach speed of the HWB is lower than the TW, HWB will permit steeper approaches and the NextGen technologies such as RNAV, RNP make the tight flight path control possible. The analysis is based on sink rate shown in Equation 11.

$$\text{Sink Rate (SR)} = \sin(\gamma) * V_{app}$$

**Equation 11 Sink Rate**

Flight Safety Foundation (FSF) recommends sink rate no greater than 1000fpm as criterion for stabilized approach. The excessive flight parameters mentioned in [Airbus 2015a] also suggests sink rate beyond 1000fpm makes the approach un-stabilized. Any flight path angle above the given sink rate curve of SR 1000, would make the approach more un-stable. The plots show combinations of flight path angle and  $V_{app}$  for different sink rates. Current operating region of conventional aircraft is shown by the red box, where the flight path angles vary between 3 to

3.5 and  $V_{app}$  vary between 120 to 160 knots [Hileman 2007]. For a flight path angle of 3.9, Tube and Wing configuration sink rate reaches 1000fpm, while the HWB still have a margin of 0.8 degrees. The maximum steep approach that the HWB with given  $V_{app}$  is about 4.7 deg.

NextGen operational environment requires steep angles as much as 6 degrees. For such steep approaches,  $V_{app}$  should approximately be below 100 knots for any aircraft for satisfying stabilized approach criterion.

Decreasing approach speed is a design concern. This can be considered at the design stage using Equation 12 and Equation 13. It can be understood from the equations that the wing loading has to decrease or  $C_{Lmax}$  has to increase.

$$V_s = \sqrt{\frac{2gW}{\rho S C_{Lmax}}}$$

Equation 12 Stall Speed

$$V_{app} = 1.3 * V_{stall}$$

Equation 13 Approach Speed

### 3. Go-around capability

Go around analysis determines the decision height required to consider flight path angle and approach speed. Operational constraints on flight path angle and final approach speed to conduct a safe, no ground contact, go-around procedure executed from a given decision height as shown in Figure 54.

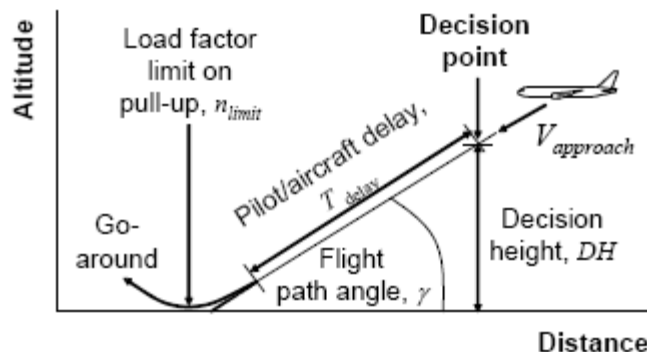


Figure 54 Go around analysis - Decision Height

#### 4. Decision Height

Decision height is the height at which the decision made to initiate go-around. For a successful go-around, the decision height is the height below which a go-around would fail leading to an accident. Mathematical model for go-around is given in [Hileman 2007] and is presented as Equation 14, and is considered for further go-around analysis. The equation terms corresponds to the cumulative height due to the delay in response time while aircraft is descending with speed  $V_{app}$ , and the pull up maneuver height requirements. The  $T_{delay}$  includes pilot/aircraft reaction time, where the aircraft reaction time can be considered as engine response time.

5.  $V_{app}$ ,  $T_{delay}$ , Flight Path angle  $\gamma$ ,  $n_{limit}$

$V_{app}$ ,  $T_{delay}$ , Flight Path angle  $\gamma$ ,  $n_{limit}$  are the parameters which define the decision height.

$$DH > V_{approach} T_{delay} \sin \gamma + \frac{V_{approach}^2}{(n_{limit} - 1)g} (1 - \cos \gamma)$$

Equation 14 Decision Height

Typical values of parameters are given in [Hileman 2007] such as DH equal to 100ft, pilot/ aircraft delay times  $T_{delay}$  typical values as 3-5 seconds (from experimental studies on human factors/pilot reaction times) and engine spool up time is given as 5secs. Operating guidelines for commercial airline pilots suggest a load factor limit of 1.3g. These are considered as typical values in the next section during analysis. The analysis is carried out in two ways.

First, we consider typical values noted above, namely load factor of 1.3, a 3 degree flight path angle, and time delay between 3 and 5 seconds, and determine the resulting sink rate and decision height for the vehicles of interest. Results are shown in Figure 55 for delay time of 3 s (left), 4 s (center), and 5 s (right). As expected the sink rate is linear with approach speed, all other values held constant, and as result the decision

height noted with contours in the plots is proportional to sink rate. It follows that the MFN has the highest sink rate and greatest decision height, whereas the HWB has the lowest sink rate and decision height.

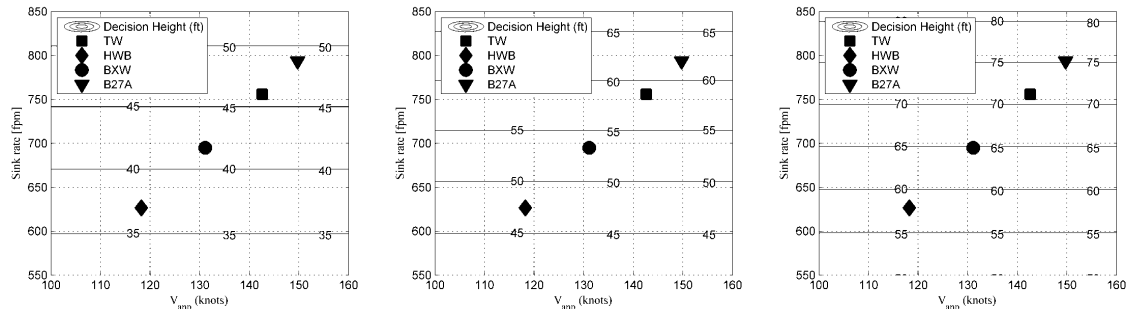


Figure 55 Sink rate and decision height vs. approach speed for fixed flight path angle and load factor

The second approach assumes a load factor of 1.3, time delay between 3 and 5 seconds, and a maximum sink rate of 1000 fpm for stabilized approach, and determines the flight path angle and decision height required. The results are shown in Figure 56 for delay time of 3 s (left), 4 s (center), and 5 s (right). By setting the sink rate for all vehicles the decision height value is also the same, as can be seen in the alignment of data points to decision height contour values. Conversely, the HWB requires an approach flight path of almost 5 degrees whereas the MFN and T&W require between 3.5 and 4.0 degrees

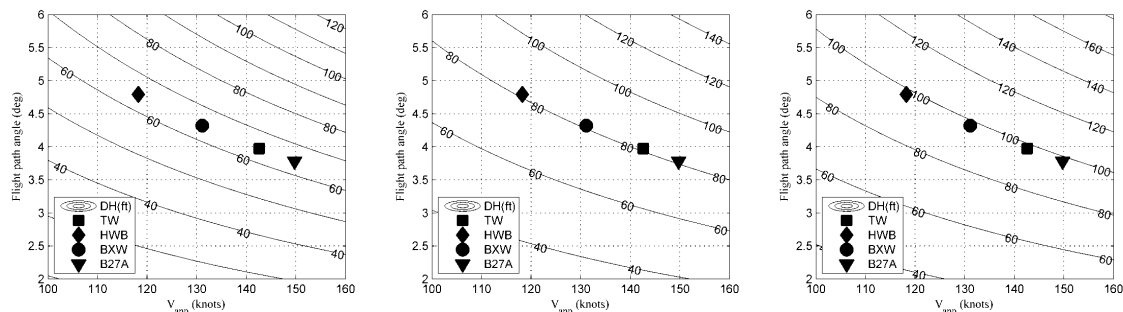


Figure 56 flight path angle and decision height vs. approach speed for fixed sink rate and load factor

## 6. Wind Shear Hazard

Similar to wind shear hazard during climb, three scenarios are analyzed

1. Microbursts in front of aircraft(Head wind)
2. Microbursts behind the aircraft(Tailwind)
3. Aircraft through Microbursts (Downdraft)

## 7. Descent Angle, Descent Speed and Descent Rate

Descent Angle, Descent Speed and Descent Rate are considered as safety proxies for quantifying wind shear hazard

## 8. Altitude, Speed (V), Thrust (T), Drag (D), Weight (W)

Altitude, Speed (V), Thrust (T), Drag (D), Weight (W) , are the properties required at vehicle level .

The analysis for windshear in landing follows the formulation and results format used for climb. Results are summarized in

**Table 13 Microburst effects on approach profile**

LANDING - Front Microburst								
End of Descent/Approach M=0.3, V=198 kts, Microburst ΔV= 60kts								
	TW		HWB		BXW		B27A	
T[lbs]	4,317	4,317	4,527	4,527	4,997	4,997	4,560	4,560
D[lb]	18,884	18,884	12,262	12,262	12,643	12,643	15,019	15,019
W[lbs]	356,849	356,849	300,590	300,590	330,875	330,875	304,884	304,884
Descent angle[deg]	2.3	3.4	1.5	2.1	1.3	1.9	2.0	2.8
Descent speed[ft/s]	333	232	333	232	333	232	333	232
Descent Rate[fpm]	816	816	514	514	462	462	686	686
LANDING - Behind Microburst								
End of Descent/Approach M=0.3, V=198 kts, Microburst ΔV= 60kts								
	TW		HWB		BXW		B27A	
T[lbs]	4,317	4,317	4,527	4,527	4,997	4,997	4,560	4,560
D[lb]	18,884	18,884	12,262	12,262	12,643	12,643	15,019	15,019
W[lbs]	356,849	356,849	300,590	300,590	330,875	330,875	304,884	304,884
Descent angle[deg]	2.3	1.8	1.5	1.1	1.3	1.0	2.0	1.5
Descent speed[ft/s]	333	434	333	434	333	434	333	434
Descent Rate[fpm]	816	816	514	514	462	462	686	686
LANDING - Down Microburst								
End of Descent/Approach M=0.3, V=198 kts, Microburst ΔV= 60kts								
	TW		HWB		BXW		B27A	
T[lbs]	4,317	4,317	4,527	4,527	4,997	4,997	4,560	4,560
D[lb]	18,884	18,884	12,262	12,262	12,643	12,643	15,019	15,019
W[lbs]	356,849	356,849	300,590	300,590	330,875	330,875	304,884	304,884
Descent angle[deg]	2.3	19.0	1.5	15.6	1.3	15.7	2.0	15.1
Descent speed[ft/s]	333	352	333	346	333	346	333	345
Descent Rate[fpm]	816	6892	514	5562	462	5614	686	5390

The results suggest that though, the aircraft is sinking through the air, the downdraft made it sink at much higher rates. Since the altitude above the ground is 1500ft which is considered for analysis, a sink rate of ~6000 fpm will make the aircraft hit ground as soon as it passes into the downburst and will not have any altitude or time left to recover.

One important aspect throughout the analysis is to assume that the aircraft controls or alleviation strategies are not being used. It is also to note that at conceptual phase this information is not available.

## 9. Stall Margin

It is very important to consider the stall margin available especially during landing and climb. The same analysis conducted for climbout is repeated here, and the results summarized in Table 14.

**Table 14 Gust margin at approach and landing**

Parameter	RTC T&W	ITD HWB	ITD MFN
$V_{App}$ [kts]	142	118	150
$\alpha_{App}$ [deg]	9.4	15.7	9.5
$C_{L,Ldg}$	1.54	0.83	1.54
$C_{L,Max,Ldg}$	2.2	1.0	2.2
Gust Margin [kts]	14	7.9	15

## 10. Engine Stall

### 11. (BWB) Engine Performance, Engine Integration and Engine Location (Qualitative)

Parameters that could be of relevance to indicate the performance of propulsion system in case of Boundary layer Ingestion (BLI) are inlet capture pressure recovery, diffuser pressure recovery, distortion (evolution and transfer across the fan), total pressure distribution at Aerodynamic Interface Plane (AIP) [Plas 2007, Daggett 2007]. Though the studies are concentrated on BLI in the reference with embedded engines, and the current aircraft has podded engines, the parameters that indicate propulsion system performance are still applicable.

Non-uniform flow entering the engine can cause instabilities that result in fan stall and even engine surge. Hence the fan and compressor of an engine must have sufficient operating margin at all flight conditions to ensure that the risk of these event is minimal [Plas 2007]. This takes the safety analysis back to design stage of propulsion system to mitigate such foreseen risk criterion. Such critical conditions impose constraint during phase.

Reference [Daggett 2007] studies the boundary layer ingestion engine inlets using active flow control for preventing or controlling separation and distortion. It is understood from this paper that in-order to estimate some of these parameters for the engines on HWB for the current scenario, details on mission point, flight attitude, operational/environmental conditions are needed to model the flow field.



Flow field modeling needs the application of Computational Fluid Dynamic tools to capture the flow of air towards the engines. Detailed engine integration with airframe, geometry details of the inlets, flow field evolution, duct losses and many more fine details are needed to calculate these parameters. Hence, this cannot be predicted with reasonable accuracy, with the current level of detail on geometry of engines, tools needed for flow field modeling, at conceptual design stage. A snapshot for distortion level calculated through detailed CFD/geometry models is shown in Figure 57 from the reference [Daggett 2007].

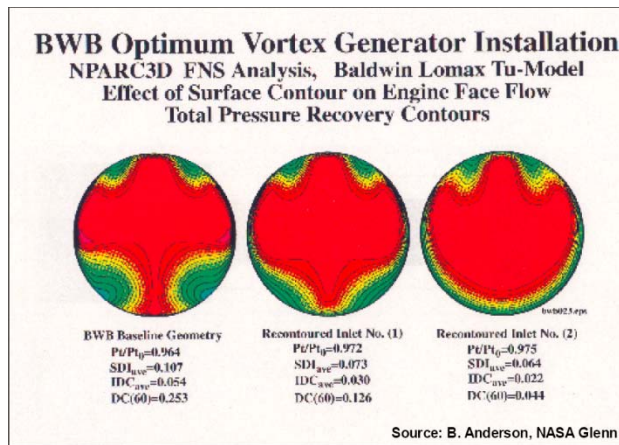


Figure 57 Distorsion Levles For Various Inlet Designs [Daggett 2007]

## 17. Landing

### 1. Runway excursion and centerline deviations

In reference [Valdes 2011] a quantitative risk analysis is performed based on the runway overrun models. Landing overrun, landing undershoot, takeoff overrun are analyzed using a probabilistic model built from historical accident database. Some of the causes for the risks mentioned above are wind, runway surface condition, and landing/takeoff required distances and available runway distances, obstacles, existence of runway safety areas. Landing with tail winds of any magnitude is a significant risk factor.

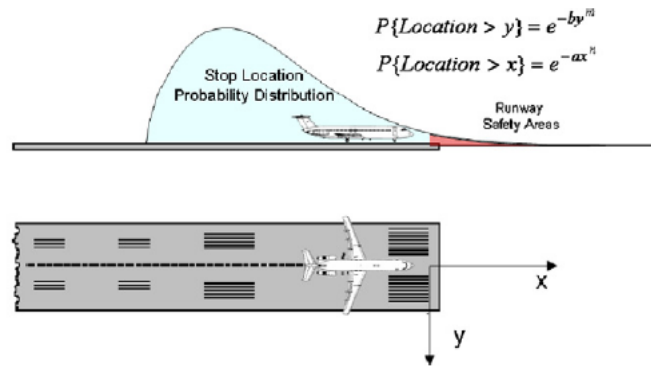


Figure 58 Modeling Runway overrun operations

Modeling distribution for the risk analysis is shown in Figure 58 and is obtained through historical accident database analysis. Each accident is analyzed and classified by cause, the contributing factor, and effect, result and the distributions are modeled to calculate the risk.

In order to calculate the overrun/undershoot risk, another approach could be a physics based model where aircraft equations of motion along with wind shear components can be solved to analyze the risk of lateral deviation and overrun / undershoot risk when specified wind conditions are present. Some of the helpful references towards this task could be [Frost 1984 , Bach 1986].

## 2. Simultaneous runway occupancy / Runway collisions

These two are dealt more rigorously in [Xie 2003] and requires operational fleet, landing intervals, runway occupancy times as distributions along with an approach and landing segments model. This can be considered once the landing module, fleet mix are modeled. It is very obvious that simultaneous runway occupancy is a necessary condition for runway collision analysis and is also mentioned in the reference. These aspects are not considered further in the analysis.

## 3. Crosswind landing (Wing Tip Strike)

Approach Techniques for cross wind landing are

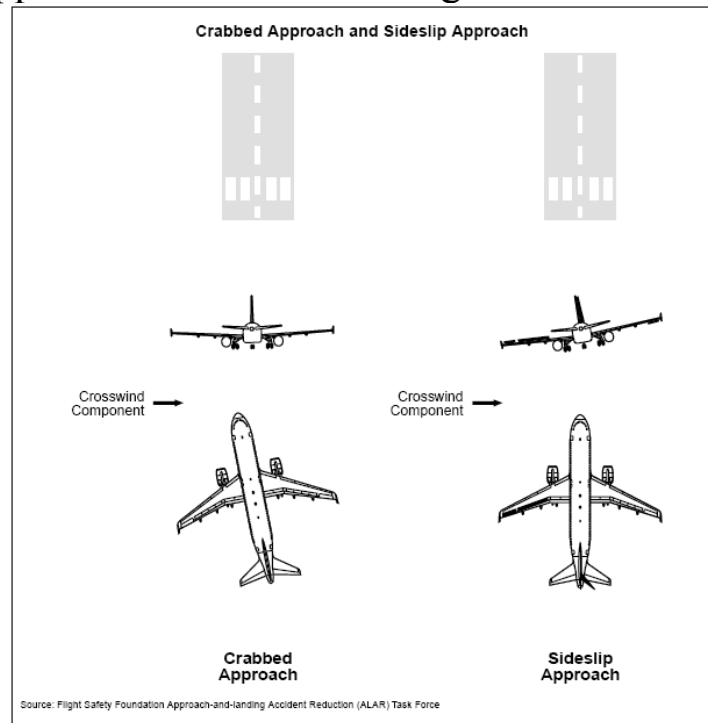
1. Crabbed Approach - With wings level, applying a drift correction to track runway the runway center line (No bank angle or rudder needed until almost the runway touch down)

2. Steady Sideslip – fuselage is aligned with runway centerline using a combination of into wind aileron and opposite rudder to correct the drift

For these approaches some of the limitations are on

1. Aircraft geometry
  - a. Tail strike, engine, nacelle strike, wing tip contact to ground
  - b. Bank angle, pitch angle limits
2. Ailerons (Roll) and rudder (Yaw) authority
3. Magnitude of cross wind component itself

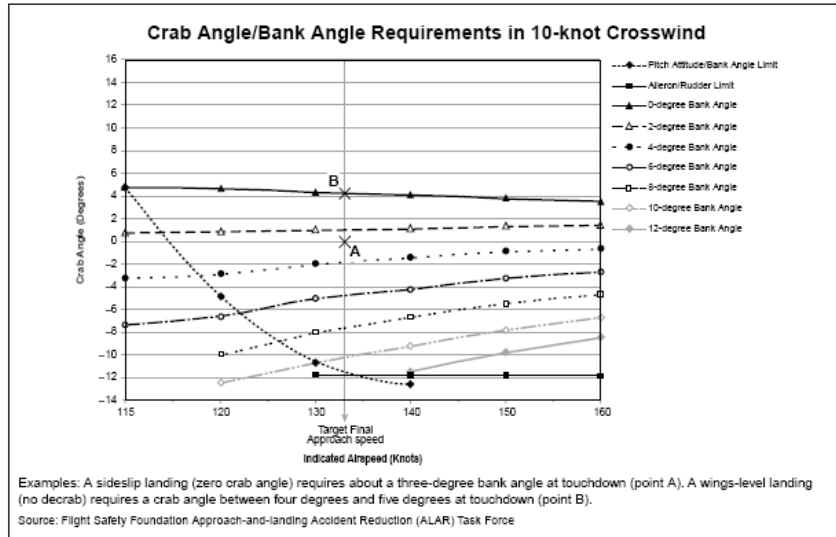
Both the approaches are shown in Figure 59.



**Figure 59 Cross Wind Approach Techniques [Flight Safety Foundation 2000]**

An operational instruction for cross wind operation can be generated for each aircraft which resembles shown in Figure 60. This chart is not universal and can be generated for each aircraft given their control strategy, control surfaces and control derivatives. To generate this chart, the forces are to be balanced in longitudinal and lateral directions and equations of motion are to be solved for each independent direction. Since the HWB doesn't have rudder authority, sideslip

approach or crabbed approach which needs runway alignment after landing, is a concern that needs to be studied further carefully for safety of landing in cross winds.



**Figure 60 Cross Wind Landing [Flight Safety Foundation 2000]**

#### **4. Bank Angle and Clearance.**

Currently only the geometric limitation of the bank angle is considered. Geometric limitation to avoid wing tip strike is calculated by constructing the wing and airframe geometry based on assumed or designed dimensions. Since the landing gear is not explicitly modeled in the sizing analysis supporting this study a parametric variation of bank angle resulting from landing gear height and location from the center body is conducted, revealing the maximum bank angles allowed by the clearance. The results are illustrated in Figure 61 for the RTC T&W. As a reference the values for the Boeing 777 are shown. Same results are illustrated in Figure 62 for the ITD HWB.

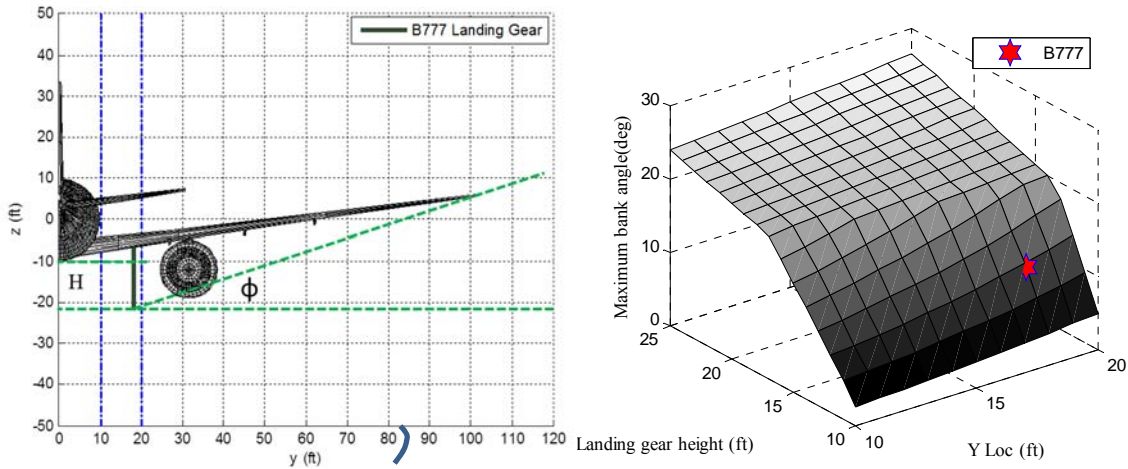


Figure 61 Wing banking clearance for the RTC T&W

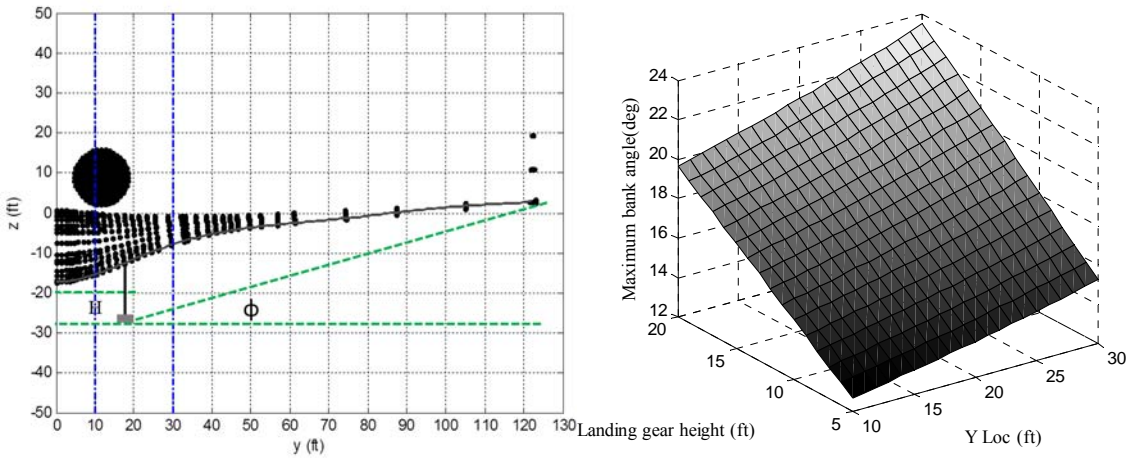


Figure 62 Wing banking clearance for the ITD HWB

## 18. Safety ATC Performance Modeling

### 1. Introduction

The purpose of this study is to examine and characterize the impact of future aircraft concepts and technologies considered by the NASA ERA project on airspace safety, particularly with respect to the potential rate of encounters between aircraft in the National Airspace. An encounter is defined as the incident occurring when one aircraft violates the minimum separation distance and enters the restricted airspace of another aircraft. This is typically given as 5 nautical miles. In other words, each aircraft in the NAS has a separation volume, the familiar

“hockey puck,” that no other aircraft is allowed to intersect. If two aircraft are too close to each other, either the pilots or the air traffic controllers must intervene in order to prevent an encounter. In the real world, air traffic controllers will intervene long before an encounter occurs. The encounter rates calculated in this study do not assume any kind of positive control, and thus provide a measure of the latent risk of loss of separation or aircraft encounters. Similarly, the encounter rates estimated in this fashion also serve as a proxy for the workload of air traffic control actors intervening to maintain a safe, orderly, and expeditious flow of traffic. In this study the encounter rate is estimated at three levels of abstraction for the national airspace system, namely, the entire system, a sector of en-route airspace, and an arrival flow at a busy airport. The assessment is conducted for current traffic levels and fleet mix as a reference, and then estimated for future years based on fleet evolution and traffic volume projections. The impact of a more diverse fleet is examined, particularly for the introduction of unconventional concepts that feature different characteristic speeds during cruise and approach.

## **2. Fleet Composition and Characteristic Speeds**

The fleet is segmented into vehicle classes based on their passenger capacity and general mission capabilities. The categories used follow those of the fleet assessment task and include Turboprop (TP), Regional Jet (RJ), Small Single Aisle (SSA), Large Single Aisle (LSA), Small Twin Aisle (STA), Large Twin Aisle (LTA), and the Very Large Aircraft (VLA). ERA concepts of interest considered here include the conventional Tube & Wing aircraft in each of the fleet categories with N+2 technology infusion, and unconventional configurations with technology infusion. The latter feature the Over the Wing Nacelle tube and wing for the LSA category, the Hybrid Wing Body (HWB) for the STA and VLA categories, and the Mid-Fuselage Nacelle (MNF) for the LTA category. The approach and cruise speeds for these aircraft are summarized in Table 15.

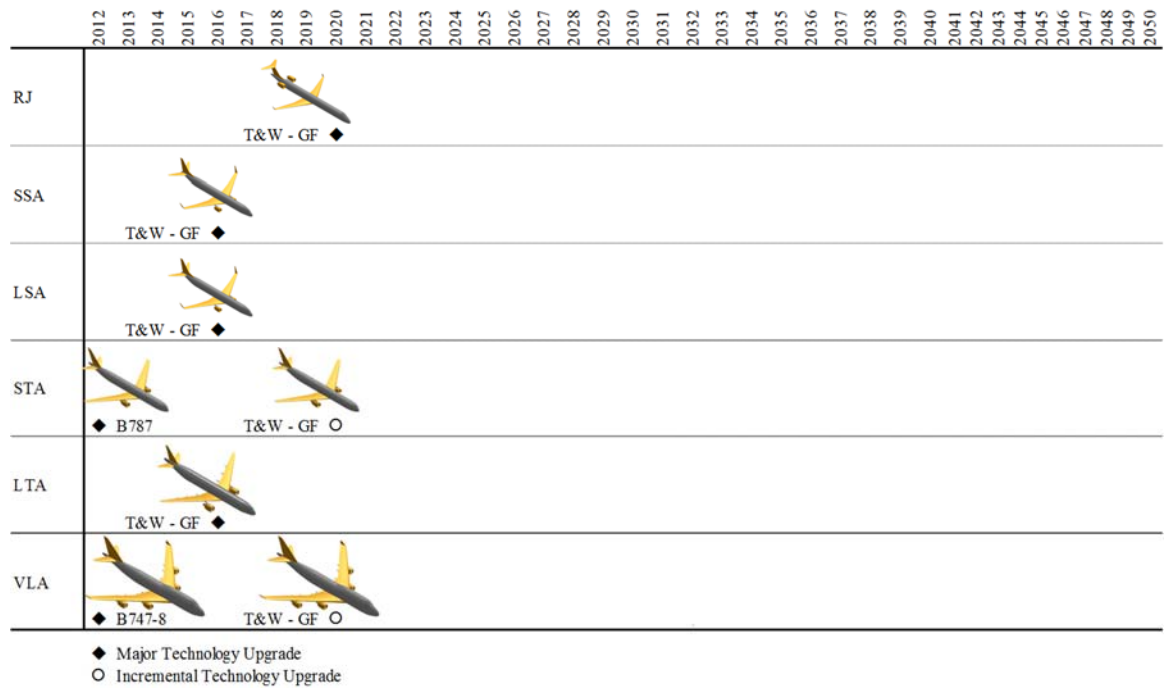
**Table 15 Fleet Vehicles and velocity for cruise and approach**

	TP	RJ			SSA			LSA		
	BL	BL	RTC	ITD	BL	RTC	ITD	BL	RTC	ITD
Approach Speed	115	126.72	130	131.6	130	132.6	135.8	140.3	142.8	145.2
Cruise Mach Number	0.45	0.8	0.8	0.8	0.78	0.78	0.78	0.78	0.78	0.78

	STA			LTA			VLA			New Config - ITD			
	BL	RTC	ITD	BL	RTC	ITD	BL	RTC	ITD	LSA OWN	STA HWB	LTA B27A	VLA HWB
Approach Speed	147.3	151.6	157.2	139	142.8	148.5	157	162.9	169.4	145.8	148.2	151.4	144.6
Cruise Mach Number	0.8	0.78	0.85	0.84	0.84	0.85	0.85	0.85	0.85	0.78	0.85	0.84	0.85

### 3. Fleet Evolution and Fleet Scenarios

Fleet evolution follows prior work conducted under this grant and published in reference [Frank 2013]. Two scenarios are defined for this study. The first scenario is the baseline and assumes new vehicle introductions into the fleet based on current, planned, or anticipated aircraft programs. These introductions reflect either major technology upgrades in all new designs or new generation variants, as well as minor technology updates in the form of current technology variants. No aircraft introductions are assumed beyond this point for any of the vehicle classes. The Reference Technology Collector (RTC) scenario is depicted in Figure 63.



**Figure 63 Reference Technology Collector (RTC) Scenario (Baseline)**

The scenario of interest, referred to as the ERA scenario, includes the introduction of additional aircraft for incremental upgrades and major technology refresh programs. It further assumes the introduction of unconventional or disruptive airframe configurations. This scenario is depicted in Figure 64.





can be non-uniform distributions for speed. It is also possible to describe uncontrolled air traffic in an area which has been structured under air traffic procedures by using other probability distributions. The initial models describe uncontrolled, unstructured, stochastic two-dimensional traffic scenarios where all aircraft are flying at a single altitude in a given ATC sector of area A. The traffic scenarios are characterized by describing the probability density functions of position, speed, and direction for all aircraft in the area. Given this information, it is possible to estimate the expected or average horizontal encounter rates, HER, for traffic. Initially, we assume that a uniform spatial distribution of traffic exists in the airspace, and all aircraft are flying on straight line paths at constant speed.

The average relative horizontal speed over all pairs of aircraft in the sector A, called the sector encounter speed, is estimated from the relative horizontal velocity for all pairs of aircraft given by

$$V_{rhij} = (V_i^2 + V_j^2 - 2V_iV_j \cos \beta_{ij})^{\frac{1}{2}}$$

The angle  $\beta$  is the difference of heading angles, namely

$$\beta_{ij} = \psi_j - \psi_i$$

Then, it is possible to estimate the encounter speed as the average relative horizontal speed between all pairs of aircraft using the following mathematical expression:

$$V_e = \int_{V_i} \cdot \int_{V_j} \cdot \int_{\beta_{ij}} (V_i^2 + V_j^2 - 2V_iV_j \cos \beta_{ij})^{\frac{1}{2}} \cdot \text{pdf}(V_i, V_j, \beta_{ij}) dV_i dV_j d\beta_{ij}$$

where  $\text{pdf}(V_i, V_j, \beta_{ij})$  is the joint probability for the occurrence of speeds and directions. If it is assumed that there is no correlation between speeds and directions for traffic in the area, then this reduces to:

$$V_e = \int_{V_i} \cdot \int_{V_j} \cdot \int_{\beta_{ij}} (V_i^2 + V_j^2 - 2V_iV_j \cos \beta_{ij})^{\frac{1}{2}} \cdot p_v(V_i) \cdot p_v(V_j) \cdot p_\beta(\beta_{ij}) dV_i dV_j d\beta_{ij}$$

$V_e$  is the average encounter speed or average relative speed between all pairs of aircraft in the traffic sector. By specifying the speeds and

directions of traffic in terms of their characteristic pdf's, it is possible to estimate  $V_e$  for any traffic scenario using analytic or numerical methods.

The general encounter model for a Horizontal Encounter Rate (HER) of a single aircraft can be calculated in the following manner. In the 2-dimensional case, it is assumed that each aircraft is surrounded by a circle of protected airspace of radius  $R$ . The width of the protected circle ( $2R$ ) is called the horizontal protection dimension. If the point representing the center of another aircraft enters this circle, an encounter has occurred. In a small period of time  $dt$ , the circle for aircraft  $i$  can be conceived as moving through a distance which depends on its average speed relative to other traffic  $V_e dt$ . It then sweeps out an area of new airspace in which it may encounter other aircraft. The concept is visually depicted in Figure 65

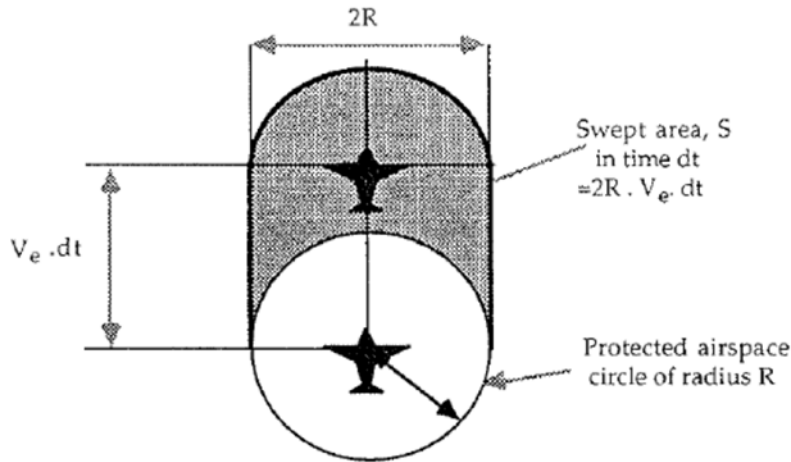


Figure 65. Horizontal swept area for horizontal encounter rate

The swept area is given by the shaded area denoted  $dS$ , where

$$dS = 2R \cdot V_e \cdot dt$$

Accordingly, the area sweep rate, which corresponds to the airspace swept by the aircraft relative to other aircraft, is given by

$$\dot{S} = 2R \cdot V_e$$

Assuming the density of traffic is constant over the horizontal area of airspace,

$$\rho_h = N/A$$

Where  $N$  is the average number of aircraft in any sector of area  $A$ , then the average horizontal encounter rate for aircraft  $I$  is given by:

$$HER_i = \rho_h \dot{S}$$

The sector horizontal encounter rate,  $SHER$ , can be calculated for an entire traffic sector by:

$$SHER = \frac{1}{2} \sum_i^N HER_i = \frac{N}{2} \cdot HER = \frac{N}{2} \rho_h \dot{S}$$

where the factor of  $1/2$  is necessary to prevent double-counting the aircraft pairs. This equation can ultimately be re-written as:

$$SHER = \frac{N}{2} \rho_h 2RV_e = N \rho_h RV_e = \rho_h^2 ARV_e = \frac{N^2}{A} RV_e$$

As shown by this equation, the sector encounter rate is a function of four key variables: the number of aircraft (traffic volume), the size of the traffic sector, the minimum separation distance, and the encounter speed, or average relative speed, which is ultimately a function of the fleet mix. In this analysis, we vary the traffic volume, as well as fleet mix, as we extrapolate into the future while keeping the size of the airspace constant. As the equation indicates, the encounter rate will follow the square of the traffic volume ( $N$ ), or traffic density ( $N/A$ ).

## 5. General Implementation for NAS-wide Estimate

The model was applied to calculate the encounter rate for a NAS-wide estimate. A rough estimate of the area of the National Airspace was calculated by adding the area of the contiguous United States of America plus up to 10 nautical miles of coastal waters all around. The traffic over the NAS was assumed to be distributed uniformly both in density as well as direction. This would provide a rough estimate for the upper bound for the encounter rate across the NAS. In reality, air traffic is organized into airways and as a result, actual encounter rate figures will be lower. Figure 66 shows the distribution of aircraft type in the NAS. Figure 67 shows that the encounter rate over the entire NAS

increases with traffic volume, as expected. The results indicate that the NAS encounter rate is directly proportional to the number of aircraft present in the NAS. Also, NAS-wide estimates do not show major differences in encounter rate between scenarios, suggesting that for a fully unstructured airspace the effect of introducing the concepts of interest is negligible.

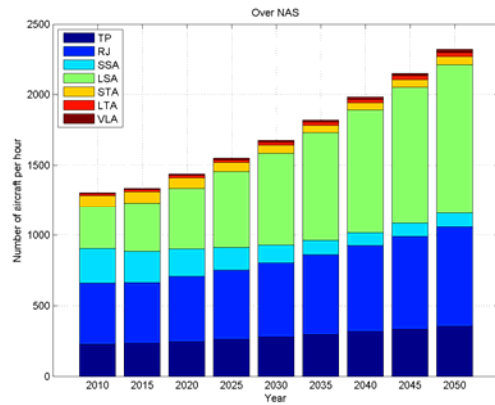


Figure 66 NAS-wide US fleet composition and evolution over time

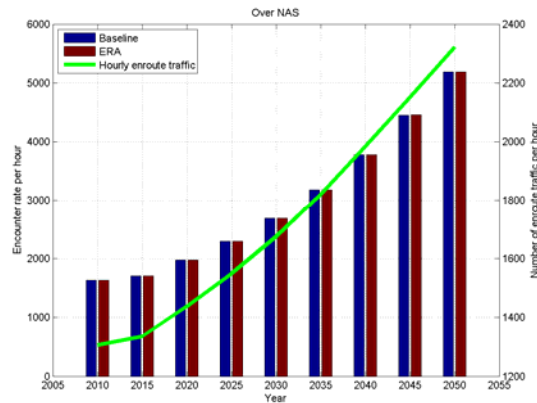


Figure 67 Encounter rate (bars) and traffic volume (trend line) for entire NAS

We conduct a sensitivity analysis where the cruise speed of the N+2 ERA aircraft was perturbed by 10% and its effects on the encounter rates were observed. The results, shown in Figure 68 show that the encounter rate increases with traffic volume, like before, but also with cruise speed. Increasing the cruise speed of ERA aircraft ultimately resulted in an increase in encounter speed, which led to the increase in encounter rates. Furthermore, the impact of these perturbations in cruise speed were more pronounced into the future. In 2050, the perturbations have a

more significant effect on the total encounter rate than in 2010. This can be explained by the increasing fraction of ERA aircraft in the NAS fleet.

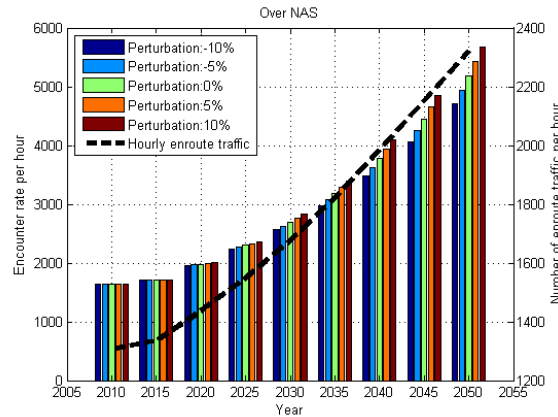


Figure 68. Sensitivity analysis of ERA aircraft cruise speed on the NAS encounter rate

## 6. Implementation for Sector Encounter Rate

The model can be extended from an unstructured air traffic model to account for an airway. In an airway, the width of an area  $A$ ,  $W$ , is made equal to the protection disc radius  $R$  of the aircraft. In the airway case, whenever a faster aircraft overtakes a slower one, an encounter has occurred. Therefore, for an area of width  $W = R$  and length  $L$ , the expression for the sector horizontal encounter rate (SHER) becomes:

$$SHER = \rho_h^2 ARV_e$$

Where  $A=LW$ . This ultimately reduces to

$$SHER = \frac{N^2}{L} \cdot V_{eh}$$

It is also possible to use the GEM to study the rate of encounters at the intersection of two airways called the Intersection Encounter Rate (IER). All encounters now occur at the intersection of the airways. Suppose there are two independent flows of traffic along two airways which intersect at an angle  $\alpha$ , as shown in Figure 69. There are  $N_1$  and  $N_2$  aircraft on each airway segment, respectively, whose average speeds are given by  $V_1$  and  $V_2$ . Then the traffic densities in the airways are given by:

$$\rho_{h1} = \frac{N_1}{W \cdot L_1}$$

$$\rho_{h2} = \frac{N_2}{W \cdot L_2}$$

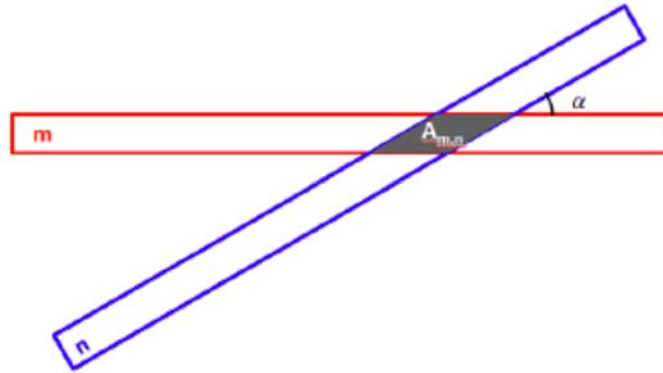


Figure 69 Intersection of two airways with angle  $\alpha$  and intersection area  $A_{m,n}$

Then, the average density along each airway can be expressed in terms of the average flow rate,  $\lambda$ , and the average velocities,  $V$ :

$$d_1 = \frac{L_1}{N_1} = \frac{V_1}{\lambda_1}$$

$$d_2 = \frac{L_2}{N_2} = \frac{V_2}{\lambda_2}$$

$$\rho_{h1} = \frac{\lambda_1}{V_1 \cdot W}$$

$$\rho_{h2} = \frac{\lambda_2}{V_2 \cdot W}$$

Thus, it is possible to express the average density of aircraft in the airway area as a function of average flow rate, average speed, and airway width:

$$SHER_{12} = IER_{12} = \rho_{h1}\rho_{h2}A_I 2RV_{e12}$$

where

$$A_I = W \left( \frac{W}{\sin \alpha} \right) = \left( \frac{W^2}{\sin \alpha} \right)$$

Since all the aircraft are flying in the directions of the two airways, which are at an angle  $\alpha$ , the encounter speed,  $V_{e12}$ , can be expressed as:

$$V_{e12} = (V_1^2 + V_2^2 - 2V_1V_2 \cos \alpha)^{\frac{1}{2}}$$

The sector encounter rate,  $SHER_{12}$ , can then be expressed as:

$$SHER_{12} = IER_{12} = \rho_{h1} \cdot \rho_{h2} \cdot A \cdot 2R \cdot V_{e12} = \frac{\lambda_1 \lambda_2}{V_1 V_2} \cdot \frac{1}{W^2} \cdot \left[ \frac{W^2}{\sin \alpha} \right] \cdot 2R V_{e12}$$

$$SHER_{12} = \frac{\lambda_1 \lambda_2 2R}{V_1 \cdot V_2 \sin \alpha} \cdot V_{e12} = \frac{2R V_{e12}}{d_1 \cdot d_2 \sin \alpha}$$

The Cleveland Center (ZOB) is one of the busiest centers in the NAS. Trajectory data for 1 month in 2006 for of 5.2M trajectory points and over 196,000 flights, was utilized for this assessment. The data was limited to the FL350 altitude band, cruise segments only removing altitude transitions, resulting in 8,500 flights. A routine was implemented to identify turning points in each trajectory, cluster turning points to identify common waypoints where heading changes occur, and then represent each trajectory as a sequence of segments connecting clustered waypoints. The resulting structure is shown in Figure 70. The encounter rate evaluation was limited to the segment with most flights for overpassing encounters, shown in red, and for the segment intersection with most flights for trajectory crossing encounters, shown in green.

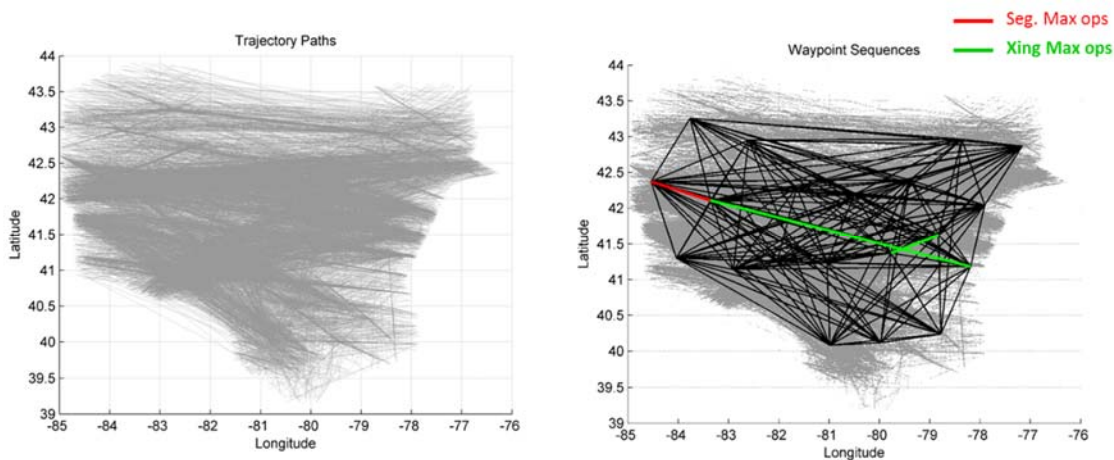


Figure 70. Trajectory data for ZOB and results of clustering approach



The model was applied to the three paths to calculate the encounter rates. Results, shown in Figure 71, indicate that the traffic per hour is quite small. Furthermore, the average travel time of an aircraft enroute through ZOB is less than 15 minutes and the maximum number of aircraft at an instant in time is less than 0.7. This results in a rather small encounter rate. Overall the impact of new aircraft in structured sector airspace is found to be negligible.

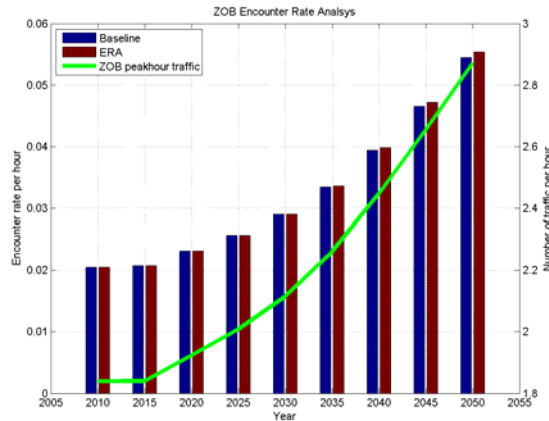


Figure 71 Encounter rate for overpass and intersections in selected paths for ZOB airspace

## 7. Implementation for Approach in Terminal Area

To generate an estimate of encounter rate for the terminal airspace, particularly for approach in arrival streams, the encounter rate model for airways is utilized. Atlanta (ATL) airport is the busiest in the world by number of operations. In its Class B airspace the FLCON standard arrival procedure is the busiest, handling all the northeast arrivals. The FLCON arrival plate, shown in Figure 72, illustrates how the altitude and speed are strictly controlled at arrival fix DIRTY. The aircraft entering DIRTY must be at or below altitude 12,000 feet and a calibrated airspeed of 250 knots.

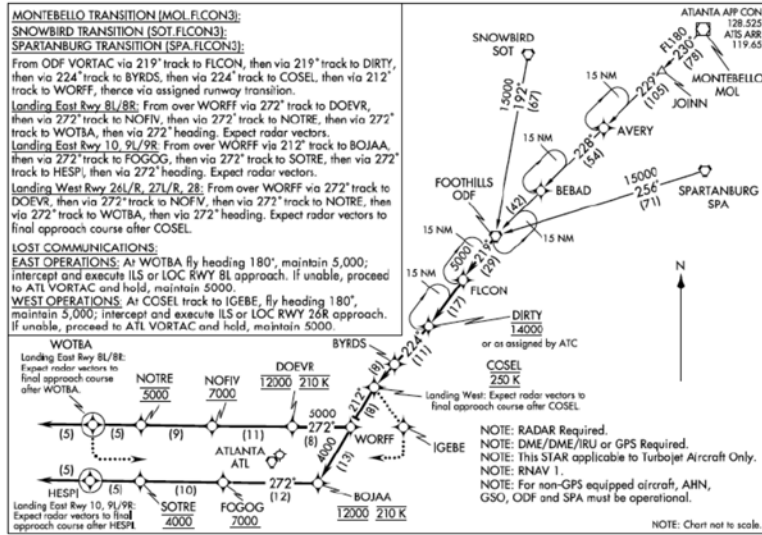


Figure 72. FLCON Arrival at ATL

Based on the operations projection and fleet allocation for ATL, the fleet composition and traffic density per hour for the FLCON arrival are as shown in Figure 73

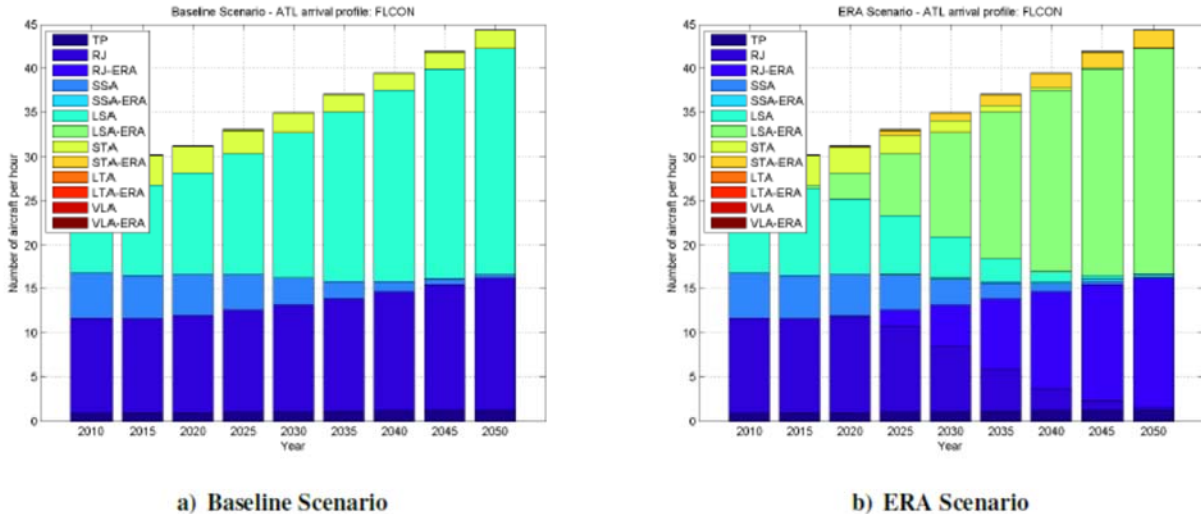


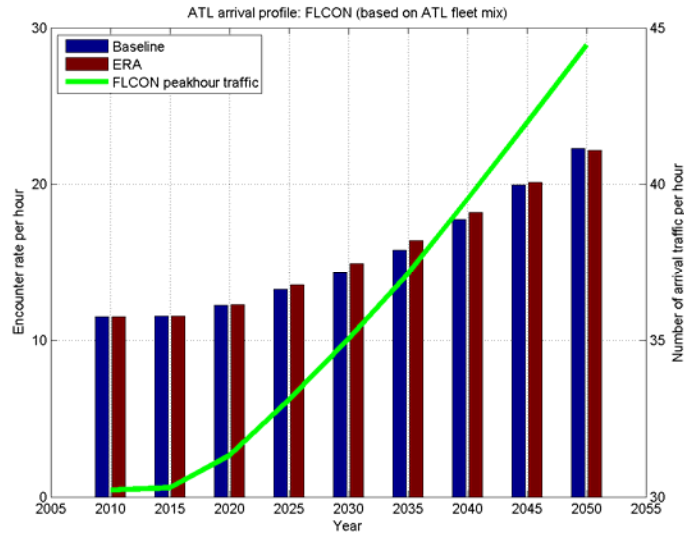
Figure 73. Fleet mix for ATL FLCON

To generate hourly estimates of arrival traffic the design day was generated with 2010 traffic data for ATL. This approach identifies the busiest month at ATL in 2010 (August), generates the average hourly arrivals to ATL in that month, and then identifies the hour with the highest number of operations as the most critical condition. In this study the peak hour is from 2pm to 3pm, and the number of arrivals is 95.6.

Some important assumptions are incorporated for the adaptation of the encounter rate model for arrival stream estimates. All aircraft follow same descent profile, consistent with highly-coordinated Next-Gen operations. Traffic intersects meter fix (DIRTY) at required 250 kts in CAS and 12,000 feet. Altitude/descent profile for all aircraft is linear from 12,000 feet to the runway (~1000 feet). Aircraft decelerate from 250 kts in CAS to approach speed linearly with altitude. For the TRACON area, 3NM instead of the usual 5NM separation distance is used. In addition, a correction to the model is incorporated to correct for the natural compression that occurs with traffic as it decelerates over the approach segment. Assuming that all aircraft reduce their speed as they progress through the arrival segment, then leading aircraft will fly slower than trailing aircraft. As a result, aircraft that may have been adequately spaced upstream are compressed and may appear as an encounter. A modified approach was developed as part of this study and is elaborated at length in Ref. [Park 2016]. The analytical expression relates the encounter rate per hour to the average flow rate  $\lambda$ , the number of aircraft  $N$ , the distance traveled by aircraft before they encounter a conflict due to compression  $dX$ , and the trajectory length  $L$ , as follows:

$$Encounter\ Rate = \sum_j \sum_{k, j \neq k} \lambda_j N_k \frac{dX_{jk}}{L} + \sum_j \lambda_j N_j \frac{dX_{jj}}{L}$$

The results of the assessment are shown in Figure 74. As can be observed the impact of introducing ERA vehicles is negligible.



**Figure 74. Encounter rate for ATL FLCON arrival fix**

As a sensitivity study the analysis is repeated with the NAS fleet mix and compared to that specific to ATL, as shown in Figure 74. Results demonstrate that the encounter rates are slightly lower for the ATL fleet mix. This can be explained by the fact that the NAS-wide fleet mix includes a much larger proportion of turbo-prop general aviation aircraft. These aircraft are the slowest fleet among the 43 aircraft types and the combination of slow leading aircraft with fast trailing aircraft has the most detrimental effect to the encounter rate calculations. As the number of these aircraft decrease (as in the ATL fleet mix). Furthermore, in the ATL fleet mix, the ERA scenario appears to become safer than the Baseline scenario around 2050.

In addition, an approach velocity perturbation was implemented as an additional sensitivity study, while the speed at the meter fix is constant (250knot). The results are shown in Figure 76 The encounter rate in FLCON fluctuates as the final approach speed of ERA fleets changes. Between 2020 and 2035, the encounter rate increases as the perturbation increases. Starting on 2045, the encounter rate decreases as the approach speed increases.

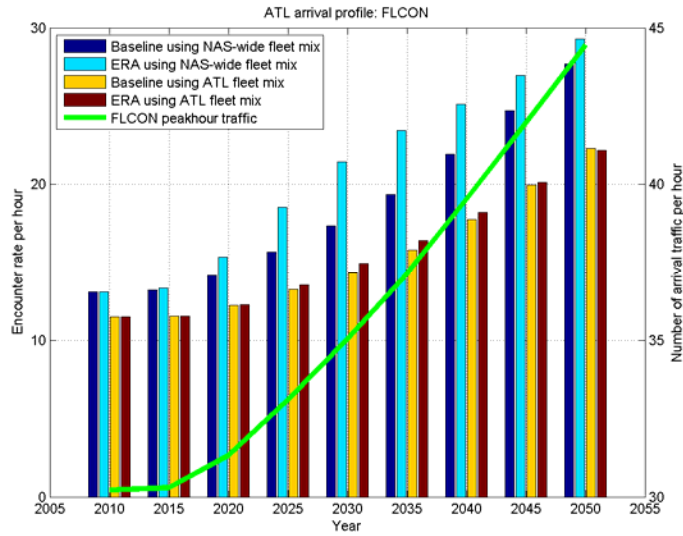


Figure 75. Sensitivity analysis of fleet composition for ATL FLCON arrival

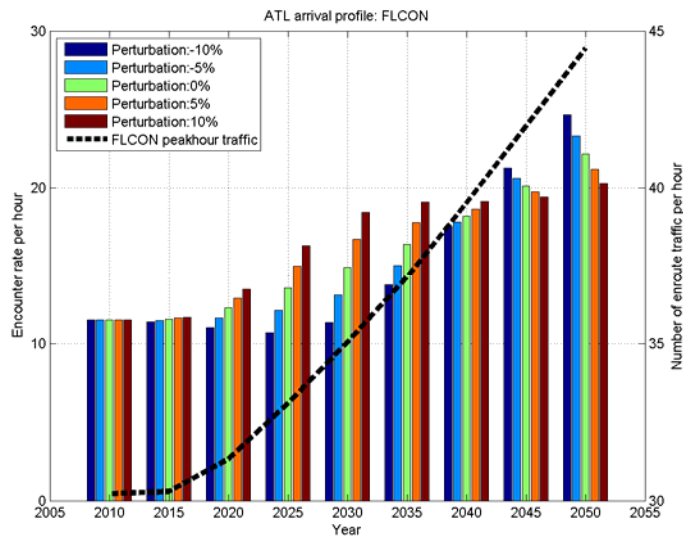


Figure 76. Sensitivity study with speed perturbation

## 8. Summary of Findings

As expected encounter rate over the entire NAS increases with traffic. The introduction of N+2 aircraft (ITD) does not have an impact on cruise encounter rate over the NAS. NAS encounter rate is proportional to N+2 aircraft cruise speed variation. Growing N+2 fleet fraction over time explains increasing sensitivity after 2025. Arrival encounter rate increases with traffic and grows over time. Arrival encounter rate sensitivity to fleet mix assumptions (NAS vs ATL) is

significant. Starting in 2025 with the introduction of N+2 fleet arrival encounter rate shows sensitivity to magnitude of approach speed change variation.

#### 4. Strategic Planning and Prioritization Calculator

The original ERA strategic planning and prioritization calculator or “dashboard,” seen in Figure 77, Figure 77. Original Microsoft Excel Version of Dashboard was developed using Microsoft Excel, mainly due to its availability and ubiquity on most computer systems. While it had several features common with the JMP dashboard presented in this report, it could only handle two vehicle types instead of the eight desired before having memory issues. Additionally, the complex calculation for the fleet metrics could not be performed in any sort of timely manner. Finally, the visualization and interactivity options were limited by comparison.

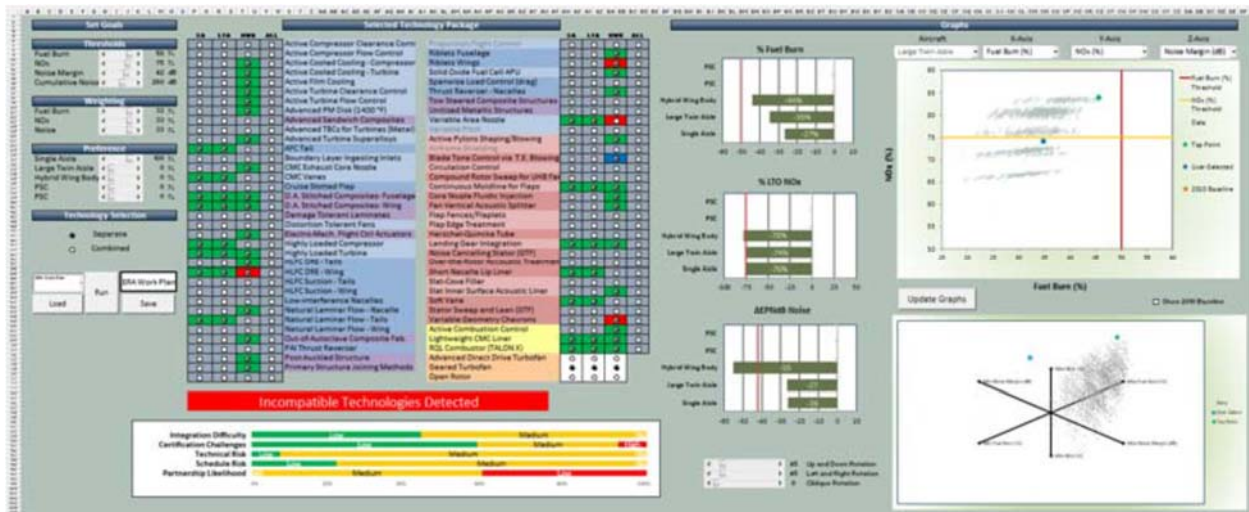


Figure 77. Original Microsoft Excel Version of Dashboard

The key enabler for the JMP dashboard is the use of surrogate models to represent the various analytical codes used to determine the aircraft performance at the aircraft and fleet levels. The use of surrogate models allow for the near instantaneous calculation of the various metrics providing for the evaluation of millions of possible

aircraft/engine/technology combinations. The surrogates are neural networks with around 100 input variables. The values for the input variables are specified by a table of technology impacts.

## 1. Dashboard Overview

There are three different levels at which technologies are evaluated in the ERA dashboard, as illustrated in Figure 78 - aircraft level, airport level and global fleet level. At the aircraft level, there are three primary metrics: 1) fuel burn reduction, 2) LTO NO<sub>x</sub> reductions and 3) certification noise. These metrics correspond to the ERA top level goals. At the airport level there are two metrics tracked: DNL noise contours for a generic airport and local NO<sub>x</sub> emissions (NO<sub>x</sub> emitted below 3000 ft. for a full day of operations at an airport). At the global fleet level, total mission fuel burn and total mission NO<sub>x</sub> are tracked for all operations across all airports for a given day.

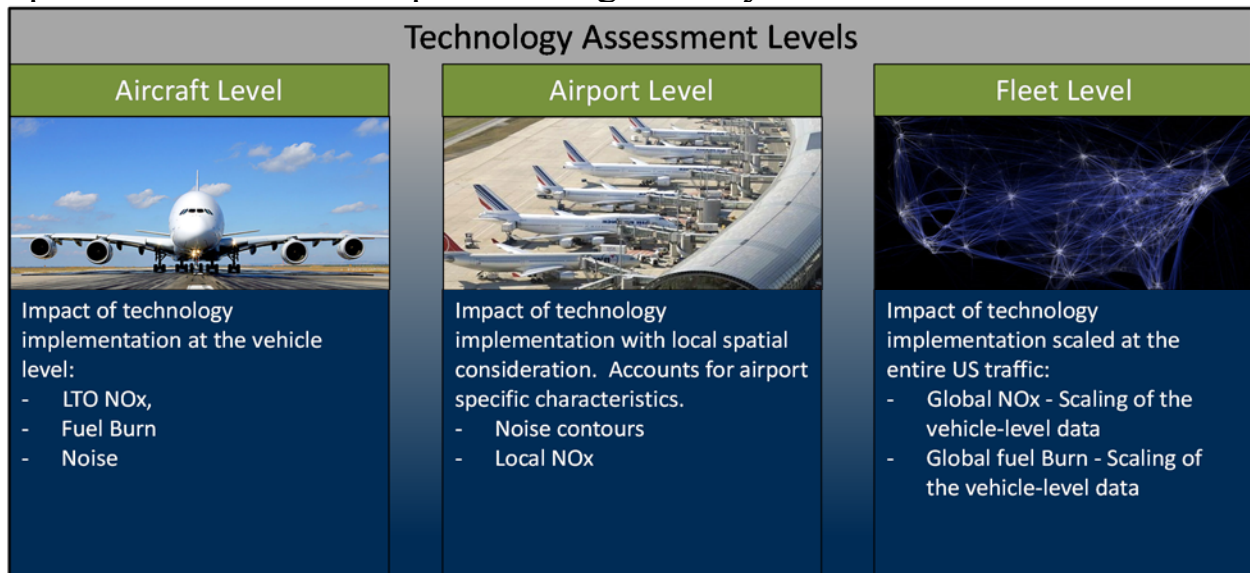


Figure 78. Dashboard Technology Assessment Levels

Surrogate models are used to enable the dashboard to rapidly evaluate metrics at each of the assessment levels. Different surrogate models are generated for each assessment level. Each level of surrogates are consistent with the previous, allowing for trade-off and understanding of interdependencies. The aircraft level surrogates are a function of the technologies, with different surrogates generated for each

unique aircraft configuration. Airport surrogates are a function of technologies, airport properties and flight schedule. The global fleet level surrogates are a function of technologies, fleet mix, replacement schedule, and operations.

The generation of the information behind the dashboard is shown in the flow chart in Figure 79. The technology portfolios and different vehicle concepts are modeled in EDS to determine the vehicle performance. This information is used to generate vehicle performance surrogates that are directly fed into the dashboard.

The fleet surrogates begin with the defining of the scenarios for technologies and aircraft configurations, combining that with a fleet replacement schedule, and then applying that to the underlying forecast. This creates the set of operations needed to generate the fleet surrogates.

Additional information from the vehicle performance previously discussed is used to generate fleet vehicle replacement aircraft by generating the XML input files for AEDT for each vehicle necessary for the different scenarios evaluated. The fleet replacement vehicles are run through AEDT to determine fleet vehicle performance. This information is used to generate noise grids for each of the vehicles, which are combined with the current fleet vehicle operations in the airport noise grid integration module (ANGIM) to generate surrogates for airport noise contours. The airport noise contour surrogates are then added to the dashboard. The final surrogates require the remaining information from the fleet vehicle performance (fuel burn and NO<sub>x</sub>) to be combined with the operations to generate the global fleet fuel burn and NO<sub>x</sub> surrogates, as well as the local airport NO<sub>x</sub> surrogates.



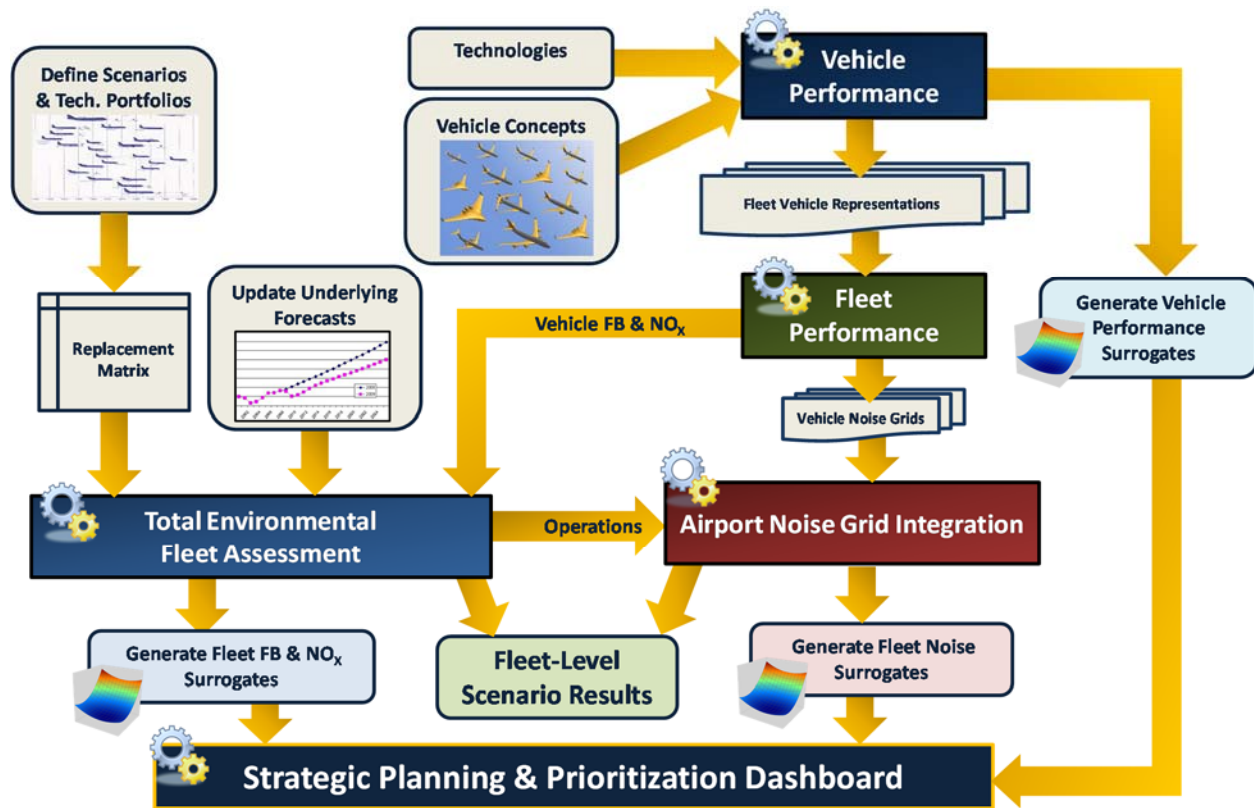


Figure 79. Information Generation and Flow to the ERA Dashboard

The ERA dashboard is broken down into multiple tabs for focused analysis and specific user defined input for the various perspectives of the program. As shown in Figure 80, these tabs include: Technology Combination Analysis, Compatibility, Pareto Frontier Comparison, Probabilistic Analysis, Fleet Definition and Analysis, Fleet Noise Analysis, and Developer Tabs. The following sections will briefly described the capabilities for each tab and some of the high level trades and types of analyses available for users and decision makers.

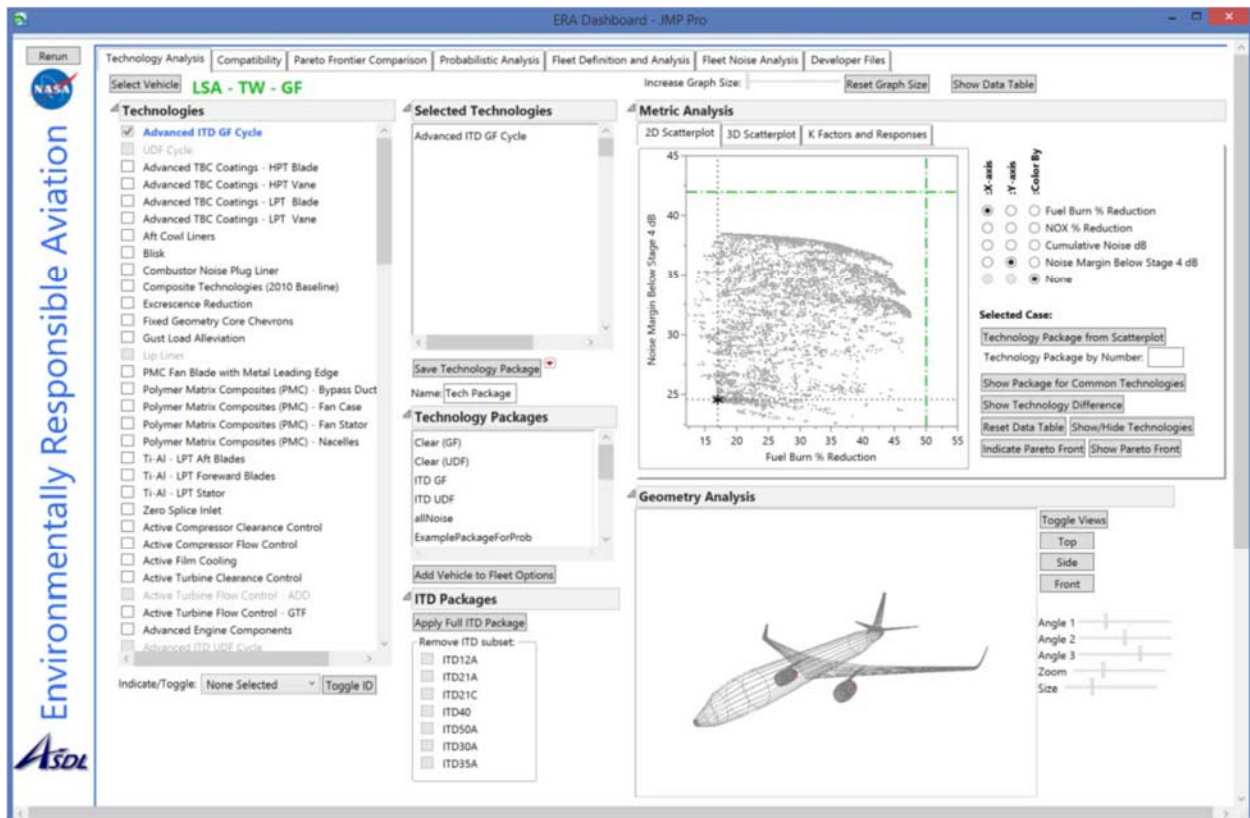


Figure 80 ERA Dashboard screenshot

## 2. Vehicle Technology Dashboard

When the dashboard is launched, the technology analysis tab is immediately displayed. The purpose of this tab is to investigate the effects of adding potential technologies of interest to the currently selected vehicle architecture to observe the performance benefits associated with the selected technologies. The process of calculating how each technology affects the vehicle that is selected is as follows.

The vehicle that is selected in the dashboard has a baseline k-vector associated with the vehicle that is loaded. The baseline k-vector is based on its 1995 baseline values. When a technology in this tab is selected, a lookup in the technology impact matrix (TIM) is performed to determine the impacts that this technology has on the k-vector of the vehicle that is selected. The TIM contains the minimum, maximum, and a deterministic impact for each technology, but this tab utilizes the deterministic value to alter the baseline values. After these values are determined, the values

in the TIM vector are applied to the baseline vector based on the combination rule from the TIM to update this vehicle's k-vector. Once the k-vector is updated, the k-vector is then sent to the surrogate models that are associated with the vehicle architecture where the surrogate models are evaluated to determine the responses based on the updated k-vector. The responses are then displayed on this tab and can be found on the K-factors and Responses tab.

When a technology is selected, the aircraft's geometry is also updated and displayed in the box shown on the tab. The grey vehicle in the pane represents the baseline vehicle, while the red vehicle represents the updated geometry with the selected technologies applied. An example of a vehicle with a technology package applied is displayed in Figure 82.

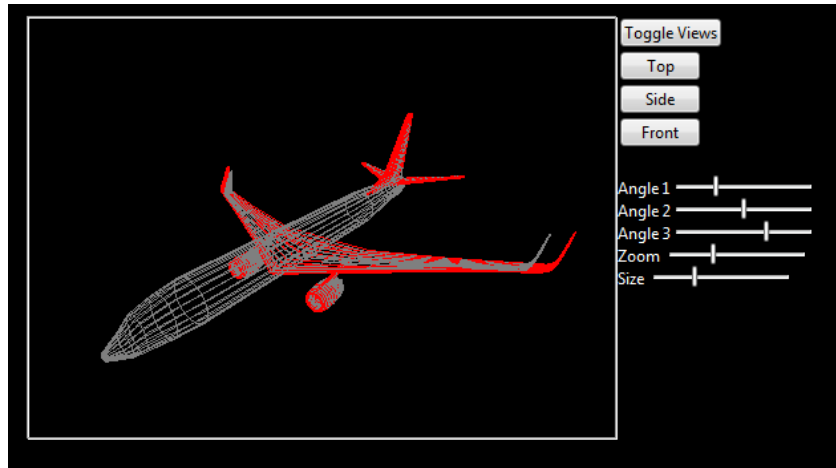


Figure 81: Updated Geometry Based on Selected Technology Package

Multiple technologies can be investigated at once on a vehicle and technology packages can be created, saved, and stored for later. If a technology package is of particular interest, the ability to save this technology as a design that can be later used in the fleet analysis calculations is also an option. Another features on this tab includes the ability to look at previously saved technology packages and also ITD packages that allow the user to investigate the responses of these packages instantaneously.

Another one of the key sections of this tab is the 2-D scatterplot displayed in the middle of the tab. This plot contains around 7,000 different technology packages for the selected vehicle. These points in

the plot are created through the use of the MOGA to find technology packages that form the Pareto frontier for the responses of concern. Once the Pareto points are found, one by one a technology in the technology package is removed and the package is resaved into another point. This process is continued until the total number of points generated is around 7,000 which forms the entire cloud of points. These plots also have the option of being displayed in three dimensions if the user desires. The two dimensional version of this plot is displayed in Figure 82.

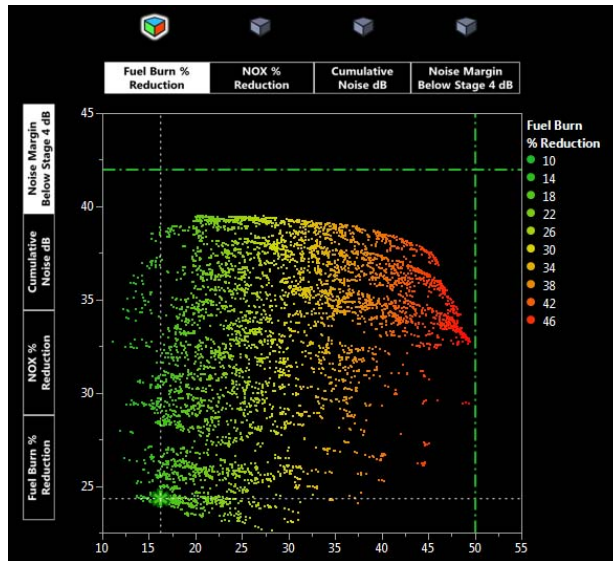


Figure 82: 7,000 Technology Packages Including Pareto Frontier for Selected Vehicle

The last main component of the technology tab is the vehicle selection column on the far left of the tab. This column contains all eight of the vehicles that the user has the option of investigating. If the user decides to choose a new vehicle, the new vehicle can be clicked and the new vehicle will instantly be loaded into the analysis. When this is performed, the baseline k-vector is updated appropriately with the new vehicle's values and the technologies that were previously selected are then reset.

### 3. Probabilistic Vehicle Analysis Dashboard

The purpose of the probabilistic analysis tab is to take the currently selected technology package and probabilistically assess the ability of the technologies to affect the k-factors. This is different from the

technology analysis tab that gives a deterministic value based on the mean of the effect that each technology affects each k-factor. Within this tab, the user also has the ability of defining the probability distribution for each individual technology and also each individual k-factor that is affected by the technology. The user also has the option of setting the number of simulations to perform when running the probabilistic analysis in order get a more accurate assessment of the probabilistic outcomes.

Once the probabilistic analysis is performed, the k-factors that are affected by the technology package are displayed in the lower portion of the tab, which shows the distribution for the number of simulations that the user chose to run when initializing the tab. The other area of key importance is the contour plots that are available for the main four responses that are being tracked in the dashboard. The user has the ability of placing one of the four responses on the x and y-axis. This plot gives the probabilistic contours that are associated with the selected technology package. Additionally, the mean and standard deviation for the responses are also displayed. Finally, this scatter plot can be viewed in three dimensions if the user chooses to do so. The same options of available responses are available to the user from the two dimensional scatterplot. An example of the two dimensional figure is shown below in Figure 83.

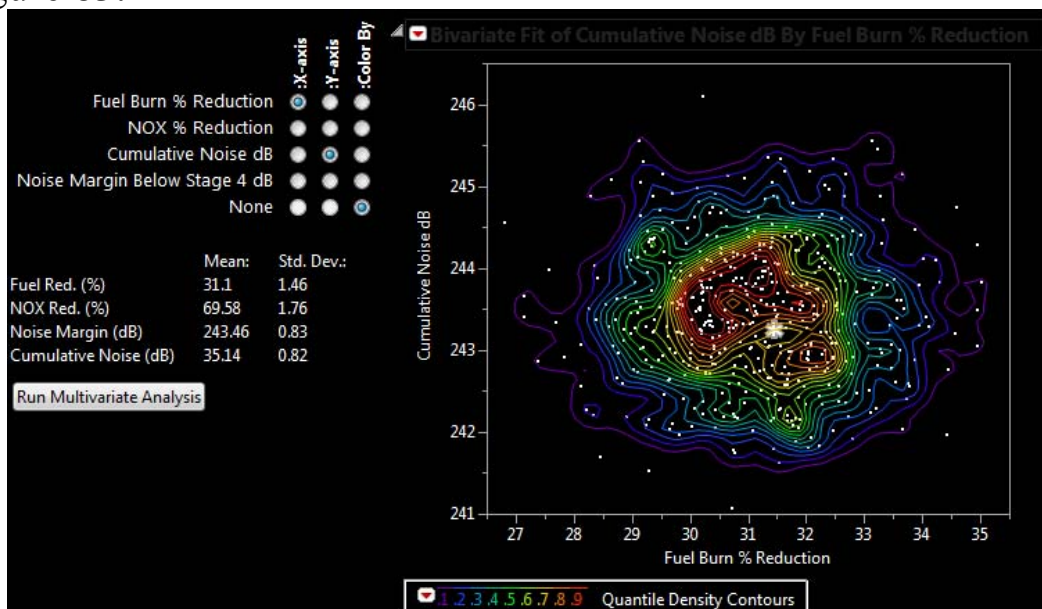


Figure 83: Probabilistic Analysis Contour Plots for Selected Technology Package

#### 4. Fleet Level Dashboard Fuel Burn and NOx

The local fleet NOx analysis tab is responsible for the calculation of the defined fleet’s local NOx calculations. When this tab is started, the fleet scenario that is loaded initially is GREAT. The resulting local NOx of this scenario can be seen in the figure below, displayed in the comparison tab. The baseline for the results is set to GREAT, while the user has the option of updating the vehicles in the scenario with aircraft designs that were saved in the technology analysis tab.

The matrix at the top of this tab represents all the eight vehicles types in the fleet which can be seen in Figure 84 with the default technology packages that are currently used in the fleet. The user has the option to click on and select the colored boxes to change these parametric vehicles with a technology packaged that has been saved from the technology analysis tab.

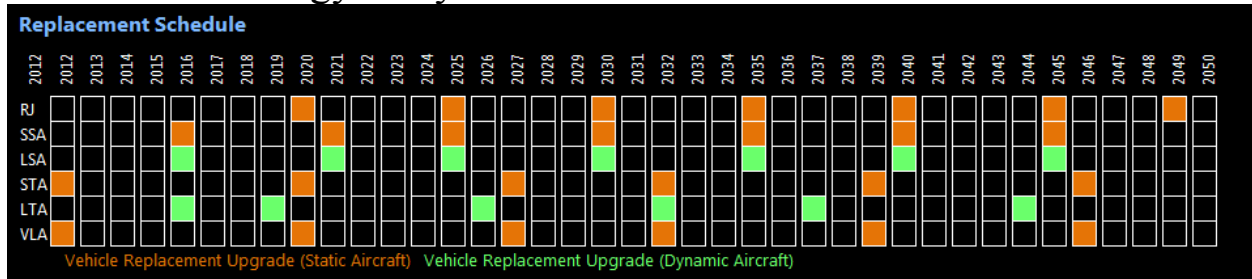


Figure 84: Replacement Schedule for Fleet Local NOx

The overall GREAT baseline scenario that is displayed is in the form of a JMP table where all the rows in the table represent either a fixed or parametric vehicle in the fleet and its operations between two defined airports. Also contained in these rows is the NOx for each section of a mission. These sections of the mission include take-off, approach, cutback, and idle. When these four quantities are summed up, the result is the total local NOx that is produced at the airport for a specific flight.

When the matrix is used to change a parametric vehicle from the fleet, the data table containing the local NOx emissions for the rows corresponding to that vehicle are updated. This process is done by taking the saved vehicle design that is being implemented and evaluating the surrogates that correspond to this vehicle type. Once the NOx responses

are known for the new parametric vehicle, the rows in the data table are then replaced and all rows are summed to obtain the total fleet local NOx for the defined fleet scenario. The process of updating a parametric vehicle can be done for multiple years where every colored box for parametric vehicles is available to be changed. After the new fleet scenario is updated, the defined scenario is displayed in the comparison chart figure near the bottom of the tab. This will display the benefits that are obtained from changing the parametric vehicle for the defined year in the fleet.

Additional figures are displayed in this tab that reveal how the buildup of the total local NOx for the fleet scenario is obtained. This can be seen under both the baseline and current scenario tabs. These figures display the contributions of each vehicle and the associated year to the total NOx production. The final figure that can be seen is the operations tab. This is similar to the total NOx buildup, but instead displays the number of operations that each vehicle and its year are contributing to the total number for the fleet scenario.

The other feature of this tab is the scenario comparison which can be found in a separate tab near the top of the overall Local Fleet NOx tab. This tab allows the user to compare 13 different predefined fleet scenarios, all of which have different goals associated with each scenario.

The fuel burn calculations through the fleet definition and analysis tab are nearly identical to the fleet local NOx analysis tab, but instead, computes the fuel burn associated with the fleet scenario instead of NOx. The baseline scenario also associated with this tab is GREAT. All of the features that are available in the local fleet NOx analysis are also available for the fuel burn analysis in this tab.

## **5. Fleet Level Noise**

The calculations performed in this tab aim at quantifying the Day-Night Average Level (DNL) 65 dB noise contour for a defined fleet scenario. The user has the option of interchanging saved parametric vehicles with technology packages from the technology analysis tab to replace parametric vehicles in the fleet to determine the benefits of

specific technology packages. The baseline scenario is set to business as usual, but other scenarios such as ERA, ITD, N2, RTC, and others are available to the user along with setting them as the baseline.

Essentially, the process of updating the fleet contours with new parametric vehicles to be introduced into the fleet is as follows. All aircraft in the flight schedule are aggregated using operations counts to an airport-level subset noise grid. In addition, surrogate models were created to quantify the noise contributions of individual operations for parametric vehicles at each location in the noise subset grid. When a parametric vehicle is introduced into a fleet scenario, the operations that this parametric vehicle is responsible for get updated in the schedule, and, as a result, the contours of the fleet noise are updated. Detailed explanation of the surrogate generation process and development of this approach can be found in [Bernardo2015].

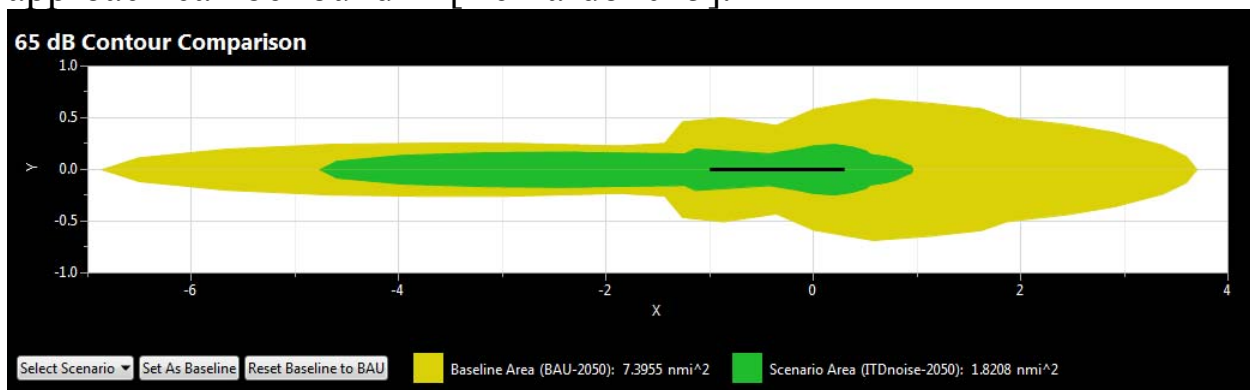


Figure 85: 65 dB Contour for Defined Fleet Scenario

### 1. Development of a Rapid Fleet-Level Noise Computation Model [Bernardo May 2015]

Future air transportation demand forecasts suggest that environmental concerns such as noise will be exacerbated beyond their current level. Although detailed airport noise modeling with tools such as INM/AEDT are available, these software require relatively long setup and runtimes due to the number of inputs available to the user and the general fidelity-level of the models. A rapid, flexible, and more simplified method that reduces the input variables to a critical few and can provide results in minutes is desired to evaluate fleet-level metrics with respect to new technologies or forecasted changes in demand.



Current lower-fidelity methods only calculate a change in contour area due to changes within the overall fleet composition. These methods cannot account for the shape of the contour. This section presents a rapid airport noise computation model that leverages the fidelity of detailed models. By performing generic aircraft operations up front, events can be rapidly recombined later to perform trades of various noise-mitigating strategies. By moving the detailed noise modeling ‘off-line’ through simplifying assumptions, the fidelity of detailed models can be channeled upstream in the decision-making process. The increased speed of the model enables multiple fleet-level analyses. Verification and validation results show agreement benchmarked against INM equivalents when model assumptions are obeyed. Comparison to detailed INM equivalents when model assumptions are violated introduces certain errors, but the model retains contour area accuracy, through the basic capture of contour shape.

1. *Approach*

The underlying concept of the generic airport-level noise model presented here is rooted in the fact that airport-level noise grids are simply logarithmic additions of all the sound exposure level (SEL) events occurring during a given flight schedule [FAA INM 2014]. Given this relationship, it is possible to pre-calculate a large number of generic single-event departure and approach events and then recombine them as the user sees fit to approximate a full airport study. Using the final airport-level noise grid, contours can be drawn and areas calculated. By doing a large number of generalized vehicle-level runs off-line, computation time of airport-level noise contours can be decreased dramatically while retaining a satisfactory amount of accuracy of detailed modeling methods. The specific steps for implementation of the proposed process are described below.

Although the concept can be stated in simple terms, the execution requires certain assumptions and management of challenges that must be discussed first. For example, any operation at any given runway at any given airport can be characterized in an infinite number of ways with respect to ground track, heading, atmospheric conditions, terrain

characteristics, etc. Acceptable compromises must be made compared to the detail normally provided by industry standard models, such as INM, to enable a rapid execution. By making several simplifying assumptions, a manageable number of generic, pre-calculated single-event noise grids can be obtained and stored for future use. These assumptions include:

1. Only two operation types will be considered (approach and departure)
2. All operations are straight-in and straight-out and are aligned with the runway axis.
3. The noise response of a single event is symmetric about the runway and ground track axes. This assumption, in conjunction with the second assumption, allow for the pre-calculation of only one half of the single event noise grid, reducing storage and computation requirements.
4. No terrain, environmental effects, or deviations are considered beyond the ‘standard day’ settings used to obtain the pre-calculated events.
5. Airport elevation is assumed to be sea-level.
6. All airport runway lengths are fixed at two nautical miles to ensure that all aircraft can be pre-calculated regardless of weight.

While some of the assumptions are more critical than others, they are necessary to significantly reduce the runtime required to produce an airport-level noise contour. The justifiability of these assumptions are analyzed and discussed throughout the modeling approach presented below, as well as the proposed validation test cases presented in [Bernardo May 2015]. The specific implementation steps of the process can be seen in Figure 86, and are explicitly outlined below.

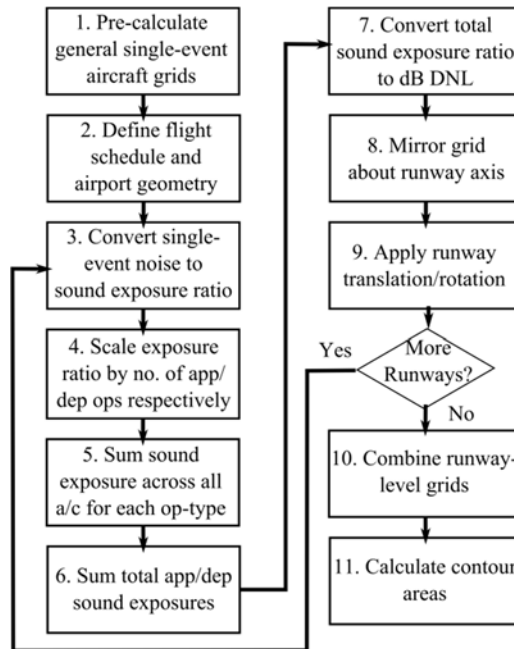


Figure 86. The steps of the model for rapidly calculating airport-level noise

Further explanation of each step and details of the implementation can be found in [Bernardo May 2015].

## 2. Conclusions

This work constitutes a summary of the verification and validation exercises performed to benchmark the proposed approach to rapid generic noise modeling: ANGIM. ANGIM was evaluated via unit-level tests and system-level tests in which the oracle (INM) both obeyed and violated assumptions. Comparisons were made with respect to point-to-point accuracy, contour areas, shape, and process characteristics of the ANGIM cases and test oracle. The results were used to characterize and summarize the expected error under various scenarios of varying conditions. The results of the validation of accuracy, especially in the context of setup and runtime, provided sufficient justification that ANGIM could be used for screening-level analyses of noise contours at the airport and fleet-level. By capturing the airport-level between the aircraft and fleet-levels, the shape characteristics of noise contours was leveraged to improve the estimation of affected area. Furthermore, since the approach was not limited to using INM as the aircraft-level grid generation tool, it was flexible enough to incorporate aircraft with

different technology packages or implemented strategies. Providing shape information improved the fidelity of communicated results, since area by itself only provided a measure of contour scale. Therefore, only a well-defined population model was necessary to rapidly estimate population exposed. It was important to note that the model proposed here was not intended as a replacement to detailed noise models, but rather a preliminary screening tool to better direct and focus the intense efforts required to perform detailed analyses of fleet-level noise. Allowing the user to perform multiple varied runs in a short period of time would enable trade studies in the technology selection space.

Based on the results, ANGIM could be used in any situation where the assumptions are reasonably obeyed, as shown by the comparisons to INM results. Unlike the equivalency and regression methods surveyed in section II-B of [Bernardo May 2015], there was no need to assume oversimplified pre-determined airport geometries. In the case of AEM, only single-runway uni-directional flow was allowed, and thus the method was only considered sufficiently accurate to provide binary decision-making, which required further detailed study. Regression methods, on the other hand, gather INM data from airports with limited geometric variability, and, thus, suffer in prediction accuracy when predictions are made for airports outside of the sample set used to create the regressions. While even the predicted areas could sometimes be acceptable, the lack of shape information made any future endeavors to predict the affected population significantly less accurate. ANGIM could therefore be used to provide significant resource reductions to evaluate a large number of cases, as long as the user properly accounted for the assumptions made. Therefore, it was most valuable in exploring cases that do not examine modifications to variables that are simplified or defaulted, as described by the assumptions, for the purposes of reducing the execution time of the process. While a breakdown in assumptions naturally resulted in loss of fidelity with respect to all metrics compared, the contour area and shape predictions still fared relatively well and demonstrated that the assumptions are defensible. The effect of divergent ground tracks was most significant to the accuracy of the

prediction, and, therefore, airports with multiple exceptionally extreme diversions might lead to increased error.

## **2. Probabilistic Assessment of Fleet-Level Noise Impacts of Projected Technology Improvements**

Several aviation demand forecasts project increases in commercial aircraft operations in the coming decades. The resulting environmental impacts of aviation operations are likely to increase if proper technology mitigation strategies are not pursued. Several technology programs are supporting the development of technologies to ensure fuel burn, NO<sub>x</sub> emissions, and noise do not become serious constraints on aviation growth. Vehicle-level environmental technologies must ultimately be judged at the fleet-level to provide a complete picture of their system-level impact. This evaluation is particularly difficult with respect to noise, as it has spatial and temporal components and is measured in daily exposure to cumulative noise levels exceeding DNL 65 dB. This exposure is evaluated by overlaying constant level noise contours with population information. At the fleet-level the summation of airport-level contour areas can be tracked as a primary metric and serve as a reasonable analog for the population exposed. Noise is typically expensive to compute, and comprehensive sensitivity analyses have not previously been possible. These analyses are now possible through the execution of Design of Experiments (DOE) combined with the development of rapid automated noise models. These models make use of simplifying assumptions to provide rapid estimates of airport-level noise. The results of these modeling and simulation techniques can be used to build surrogate models and examine the relative impacts of the important operational variables with respect to noise. Using representative aircraft and airport models to represent the diversity present in the system, this research generated surrogate models to represent the system-level noise as a function of airport operational factors. The surrogate models developed were applied to a future forecast year, simulating technology and market performance factors to identify vehicle classes that could have the greatest impact in reducing contour area. The technology and market performance of future notional

Small Single Aisle and Large Single Aisle vehicle aircraft were found to have the highest correlations with potential reductions in contour area.

1. Methodology

To construct a set of models which represented the fleet-level impacts of noise, the methodology summarized in Figure 87 was used. Each step of the process is explained, including how previous researchers have performed these tasks, if and when a new approach was developed, and any important assumptions required.

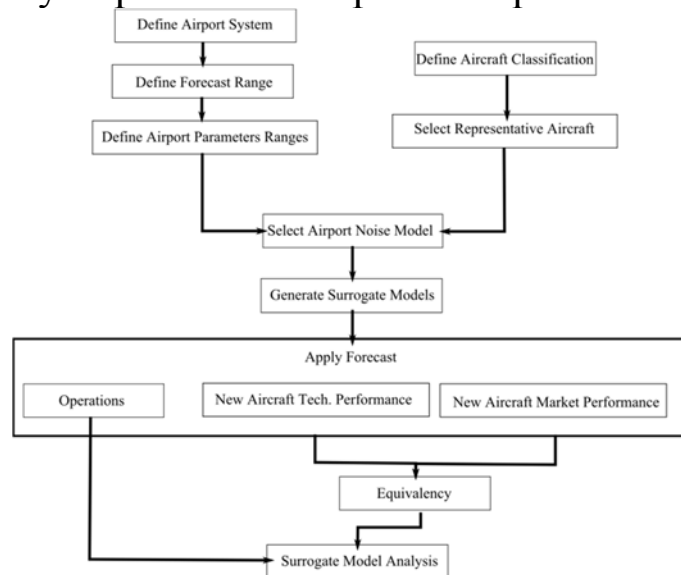


Figure 87. Analysis methodology. Approach enables rapid tradeoffs of system-level technology impacts to noise.

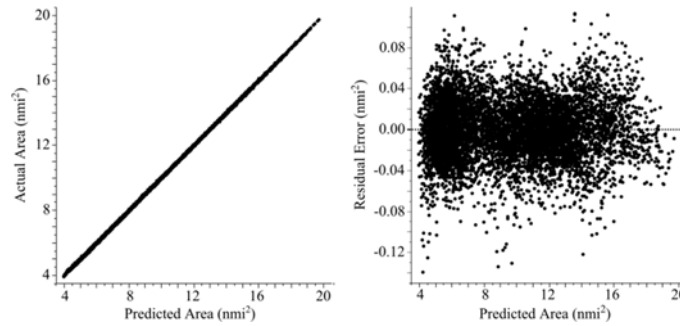
These steps can be listed as:

- i. Define Airport System and Forecast Range
- ii. Define Aircraft Classification and Select Representative Aircraft
- iii. Define Airport Parameter Ranges
- iv. Noise Model Selection and Surrogate Model Generation
- v. Applying Forecast and Equivalency Modeling
- vi. Technology Scenario Analysis
  - a. Reference Technology Scenario
  - b. N+1 Technology Scenario
  - c. Operational Uncertainty & Stimulated Market Analysis

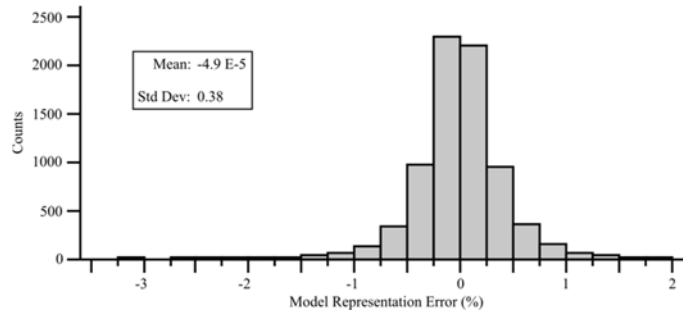
## 2. Calculation

Surrogate models for the contour area were generated and checked to ensure they produced reasonable fits. An Artificial Neural Network (ANN) was used to generate a surrogate model of contour area as a function of the input variables for each generic airport model. Each surrogate model is a function of the vehicle class mixture variables, the total operations, day-night fraction, and the vehicle class stage length settings. In the interest of brevity only the L1 generic airport surrogate model will be discussed in detail.

The L1 surrogate model had a coefficient of determination ( $R^2$ ) of 0.99, and a Root Mean Square Error (RMSE) of 0.029 nmi<sup>2</sup>. The actual-by-predicted and residual-by-predicted plots are shown in Figure 88. The actual-by-predicted plot shows good agreement from the predicted model and includes both fit-cases and validation cases. The residual-by-predicted plot shows a distributed scatter of model residuals about the line of zero error, and also includes fit-cases and validation cases. The magnitude of the residuals is sufficiently low to accept the validity of the model. The Model Representation Error (MRE), shown in Figure 89, measures the ability of the model to predict cases used to create the model, as well as cases that were not used in fitting. The error distribution shows a mean near zero, with a relatively low standard deviation, which also supports the validity of the model. Table 16 summarizes the fit statistics for the remaining generic airport models. Each generic airport surrogate model demonstrates a high  $R^2$ , low RMSE, error distribution mean near zero, and a low standard deviation of error. Smaller generic airport models, particularly the S3 model, were more difficult to fit, as the contours are small, causing the relative error of the contour area to increase significantly. Despite having good fit statistics, outlier cases with very low contour areas resulted in larger standard deviations in the error distributions.



**Figure 88. Actual and residual by predicted. Fit and validation cases both included.**



**Figure 89. Model representation error. Error distribution approximates a Gaussian distribution.**

**Table 16 Surrogate model fit statistics. Overall low error distribution means and standard deviations.**

Generic Airport Model	R <sup>2</sup>	RMSE (nmi <sup>2</sup> )	MRE Mean (%)	MRE Standard Deviation (%)
S1	0.99	0.01	0.02	0.67
S2	0.99	0.02	0.00	1.34
S3	0.99	0.01	0.01	1.68
M1	0.99	0.02	0.00	0.40
M2	0.99	0.03	0.01	0.63
M3	0.99	0.02	0.01	0.84
L1	0.99	0.03	-4.90E-5	0.38
L2	0.99	0.01	0.01	0.14

The scenarios described in Technology Scenario Analysis section were executed through the surrogate models generated to model the airport noise space. These results are discussed with respect to in-group and fleet-wide impacts of the various vehicle classes to the overall response in the results section. Discussions of the results are provided in tandem with each scenario. The surrogate models were used to obtain the baseline contour areas for the generic airport models, which are used to make all results relative to the nominal year.



### 3. Conclusions

This research presented the results of a set of surrogate models designed to predict the behavior of airport noise contour area with respect to several operational factors as modeled in ANGIM. Operational factors examined included total operations, vehicle class distribution, trip-length distribution by vehicle class, and day-night fraction. The surrogate models were constructed by performing Mixture-Design of Experiments (M-DOE) crossed with typical Design of Experiments (DOE) methods around the airport operational models. The airport models constitute average representations of the operational characteristics of the MAGENTA 95 airports in the baseline and forecast years analyzed. Aircraft operations were modeled utilizing generic vehicles, designed to represent the baseline fleet with a single model for six vehicle classes. The models were used to perform several probabilistic scenarios, simulating the noise reduction technology and market performance of each vehicle class through an equivalency mapping.

The first scenario modeled a notional future forecast year, assuming only introduction of current-day technology aircraft using conservative ranges on technology performance. These factors were mapped to the surrogate models using an equivalency approach, where a technology-aircraft is modeled as a percentage of operations of the baseline aircraft. The results of the simulations showed that no future scenarios resulted in system-level reductions to the noise contours, subject to the notional input assumptions. Nevertheless, the results enabled the computation of multiple correlation statistics for each vehicle class, to determine which had the greatest impacts at different airport types.

The second scenario modeled the same notional future forecast year, but with an expanded range on the optimistic side of the noise reduction technology distribution. The new optimistic value was selected based on N+1 program targets. These results demonstrated a potential set of conditions under which improvements to the baseline contour area could be achieved. Reduction in contour area at the system level relied heavily on Small Single Aisle aircraft performing well with respect to both

technology performance and market penetration, although the impacts varied at different generic airport types.

Finally, an operational uncertainty and stimulated-market analysis example were demonstrated. The former demonstrated the impact of +/- 10% uncertainty in total operations growth, highlighting the sensitivity of the contour area to the total operations. The latter demonstrated the impact of notional market stimuli for the Small Single Aisle and Large Single Aisle vehicle classes in the N+1 scenario by modifying the input distributions. These examples serve to demonstrate how the system of surrogate models can be used to rapidly analyze a host of potential technology and market conditions given expert input.

The results presented are intended to show qualitative trends of potential future scenarios. The confidence in the results are ultimately functions of the models used to develop the surrogate models, the quality of the surrogate models, and the assumptions utilized in the simulation of technology improvement and market penetration. Several improvements can be made to the framework established to provide greater confidence in the results.

One limiting assumption of the analysis was an equivalent reduction in noise at all three certification points, which essentially extends to assuming an equivalent reduction in noise at all locations. While the reduction in noise at the certification points must always be assumed, the approach certification noise reduction can be decoupled from the takeoff and sideline certification noise reductions by constructing surrogates that are also a function of approach and departure fraction. While this variable is generally nonsensical because airports generally have a similar approach and departure count, it can be used to subtract operations specifically from either type to distinguish between technology reductions in approach or departure noise. Further research could introduce airport geometry as a variable. While the qualitative trends should not be affected, the total fleet-level area predictions would improve in accuracy. The relative importance of some operational factors may also be affected by more complex contour shapes. The impacts of capacity constraints and additions of new runways could also be examined with the introduction of geometry. Also, instead of tracking

contour area, population exposure or housing units would provide a more relatable measure to users, while also making it easier to connect the models to a cost function. The models are very sensitive to the distributions used in the simulations, and these must be chosen carefully, with expert-driven input, to provide results with greater confidence.

Beyond improving the validity of the models developed, the framework can be applied to a host of different problem formulations. The equivalency assumption essentially projects any changes to the modeled system as an increase or decrease in operations, which enables the analysis of a large number of potential factors using extremely simple surrogate models. For example, a scenario to measure the impacts of M1 airports imposing a noise tax could be analyzed, resulting in airlines strongly considering heavier use of technology-infused aircraft. Allowing for this type of system articulation is simply an extension of the work presented here, and only requires appropriate data sources or reasonable assumptions to achieve. The analysis could also be used to examine the impacts from a normative perspective, assessing the amount of technology improvements in noise reduction and market performance required to achieve system-level improvements. Finally, combining the ability to predict technology impacts to system-level noise with fuel burn and NO<sub>x</sub> predictions is ultimately necessary to analyze the competing trends between these three critical metrics. Combined analyses will enable tradeoffs to find technology investment solutions that enable aviation to grow as expected without undue environmental strain.

These results are meant to demonstrate the capability in combining DOE techniques with a rapid simplified noise model like ANGIM to explore the factors that drive system-level noise. By understanding the link between different vehicle classes, flight proportion, total operations, and general airport operational diversity, better-informed technology investment and policy decisions can be made that will ensure that the future of aviation will not cause significant negative impacts due to airport noise.

**3. Application of Mixture Design of Experiments for Dynamic Fleet-Level Evaluation of Multi-Objective Environmental Technology Trade-offs [Bernardo 2014]**

Recent and projected increases in aviation demand have caused concerns that the environmental impact of aviation may also increase if not properly mitigated. Such issues have engendered technology identification programs to investigate and invest in technologies to reach a level where industry can implement these technologies. Design methodologies have similarly been under development to provide sophisticated frameworks for analyzing large libraries of technologies and technology combinations. While vehicle-level evaluation is critical in any aircraft design, from an environmental metrics standpoint, fleet-level analyses are much more instructive. Evaluating technology impacts at the fleet-level is typically a matter of scaling vehicle-level metrics by the number of flights. For noise, however, because the metric is the contour area of a fixed Day-Night Average Level, this vehicle-to-fleet scaling cannot be done. Noise contours must be calculated from a noise grid of noise levels at various observer points. At proper grid refinements, this would be akin to scaling hundreds of thousands of vehicle-level metrics to the fleet-level. This time consuming process hinders the ability to analyze fleet-level noise dynamically in concert with fuel burn and NOx emissions. Of particular interest is the ability to dynamically change technology variants at the vehicle level, to enter the fleet and measure the environmental impact dynamically. Because of the spatial and temporal nature of noise, fleet-level surrogate modeling requires sampling an airport-level model directly and creating surrogates at the airport-level that can then be scaled to the fleet level. The fleet problem is cast as a mixture-of-mixtures-plus-process-variables problem where the aircraft classes and their variants are the mixture-of-mixture components, and the total flights etc. are the process variables. To analyze this space without reducing model terms, however, requires a caseload in the hundreds of billions. Even a screening test of the space requires too many cases. The terms that can be removed, however, are unknown a priori. The research examines a reduced fleet-level problem at sequentially increasing layers of complexity, characterizing the

response space along the way and identifying which factor interactions can be eliminated from the surrogate model. The resulting models are combined with fleet-level fuel burn and NOx emissions models to examine notional technology scenarios. Recommendations regarding the future use of the traditional mixture-modeling framework as applied to the fleet-level noise prediction problem are provided.

1. Problem Formulation

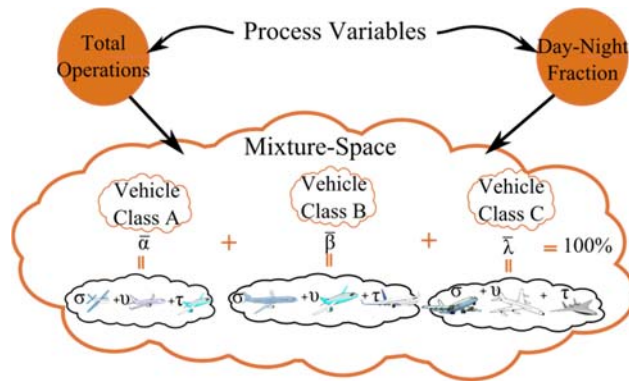


Figure 90 Mixture-of-Mixtures. Process variables also impact the mixture-of-mixture space.

In the fleet-level problem, each aircraft is a component of the mixture, much the same way that ingredients for a cake are treated. Generic vehicle classifications, developed in [LeVine 2014], can be utilized as high-level vehicle types. In the cake analogy, this classification would be similar to separating ingredients as ‘dry’ and ‘liquid’. The proportions of these types with respect to each other describe the overall fleet distribution. Within each vehicle class, there is baseline and technology infused aircraft, which are similarly defined as a separate mixture of components. Again, in the cake analogy, within the ‘dry’ ingredients category there may be flour, cocoa, and sugar among other ingredients, which are combined in relative proportions in the ‘dry’ mixture. The result is a mixture-of-mixtures problem. [Cornell 2002, 2011] The mixture of vehicle classes is called a Major Components Mixture (*M*-Mixture), while the mixture of vehicles within a class is called a Minor Components Mixture (*m*-Mixture). [Cornell 2002, 2011] In order to model interactions in-and-between the *M*-Mixture and *m*-Mixtures, an exponentially larger number of cases are required.

The total number of operations constitutes the amount of the mixture. [Cornell 2002, 2011] Other ‘process’ variables, such as the day-night fraction (relevant for fleet-level noise) can also be accounted for in the current framework developed in the literature. Process variables are non-mixture variables that represent external conditions that impact the entire mixture. [Cornell 2011] In the cake example, this might include oven temperature, cooking time, or ambient humidity in the kitchen. In fact, the amount of the mixture is just a special case of a process variable. [Cornell 2002, 2011] A graphical representation of the mixture-of-mixtures-plus-process-variables problem can be seen in Figure 90.

## 2. Key Challenges

To fit a second-order model that accounts for these variables for each Generic Vehicle class, and allows for several technology variants per class, would require a prohibitive amount of cases. These are the cases required to capture the interactions between the  $M$ -components, the interactions between the  $m$ -components, and the interaction between the  $M$  and  $m$ -components. Finally, the interaction between the aforementioned effects and the process variables must be captured. In order to model all of these interactions, several traditional DOEs and M-DOEs must be crossed. Therefore, even a relatively small problem quickly cascades into an infeasible number of cases. In order to fully model all main effects and 2-factor interactions for eight vehicle classes, two technology vehicles per class (plus the baseline), and the fleet-level process variables would require approximately  $7E10$  cases. Naturally, all of these terms are not necessarily significant, and a large number of them can be reduced. A basic screening design for this problem would still require approximately  $1.8E10$  cases.

Even if these experiments were all possible, the delineation of variables described above would require a set of specific technology infused aircraft variants. Consequently, the experimenter would have to know a priori the technology variants to be integrated into the fleet. The resulting surrogate models built from this information would only be sufficient to analyze the impact of varying proportions of technology vehicles with a fixed technology set. This situation creates incongruence

with the desire to dynamically examine multiple various technology options.

This issue uncovers perhaps the fundamental difference between casting fleet-level environmental analysis as a mixture problem and traditional mixture problems. The aircraft (the ingredients in the fleet-level recipe), can be substantially manipulated to produce a different environmental response at the vehicle-level over a continuous, multi-dimensional design space. The capability to *design* the components of the mixture, either through vehicle/engine characteristics or technology factors, expands the amount of design space that must be explored to provide sufficient surrogate models to address even a scoped fleet-level noise problem. In order to provide a dynamic link from fleet-level noise responses to changes at the vehicle-level, the surrogates must predict the contour area response directly, precipitating the need to implement M-DOEs.

### 3. *Research Objective*

The current canonical framework of M-DOE implies accounting for vehicle-level variables as process variables. The addition of these process variables, however, only further increases the dimensionality of the problem. As is the case with many mixture experiments, there are usually not too many mixture components of interest (generally fewer than six). [Cornell 2002, 2011] In the fleet-level problem, the aircraft space has already been reduced to generic vehicle classes, and further removal of these mixture components would defeat the purpose of examining their effects on the environmental responses. A typical screening approach could be attempted, but would require prior justification for removal of general sets of terms. This approach would not provide generalizable information about which variable types typically do not interact and can be defaulted. For example, there is likely little interaction between the technology factors modifying an aircraft of one vehicle class and the *m*-Mixture proportion of the baseline aircraft, but this is not explicitly known.

Instead, this research proposes to decompose the problem into a series of tests, sequentially adding layers of complexity to a reduced

fleet-level noise mixture problem. At each stage significant terms can be identified to draw inferences over which variable types are significant. By decomposing the mixture-of-mixtures-plus-process-variables problem into its parts, general information regarding which interactions can be ignored in a larger-scope fleet-level noise problem can be retained. By proceeding through different levels of complexity of the M-DOE fleet-level noise problem, the interactions between different model effects can be identified and evaluated to determine which are necessary to carry through the next level of M-DOE complexity, and which can be defaulted. By reducing the dimensionality of the terms in the mixture model at each level, the interactions between differing variable types can be identified, while maintaining a case load that is reasonable utilizing rapid fleet-level analysis tools. This process will be used to evaluate the utility of the classical M-DOE framework in creating a fleet-level noise response to changes in aircraft-level technology infusion.

#### 4. *Approach*

In order to reduce the number of cases required to fit surrogate models for fleet-level noise, the strategy presented here consists of fitting models of increasing complexity. At each level of complexity, the model must be used to screen the factors and subsequent factor interactions that are most important to providing accurate trend predictions. As a result, the crossed M-DOEs required for higher levels of complexity will be fewer, and support building a more complete fleet-level analysis.

The tools, models and sequential model reduction tests used in this research as well as the details of implementation are provided in [Bernardo 2014].

#### 5. *Discussions*

The M-DOE framework was applied to a significantly scoped fleet-level analysis, introducing vehicle-level variables to the fleet-level noise prediction model while capturing uncertainty in total operations, day-night-fraction and vehicle class proportion. This proof-of-concept considered three aircraft classes, the SSA, LSA, and STA, allowing only



the SSA aircraft class to receive technology infusions. The major challenge in expanding this problem to a more complete fleet-level analysis remains a function of how the vehicle-level design variables are treated in the fleet-level model. Across a forecast, it is likely that a handful of aircraft would be introduced for every vehicle class. Moreover, each technology aircraft carries along its own set of design variables that must be crossed into the model. In this study, only 9 variables were considered, but that list could easily be expanded to include other critical factors.

In order to scale this problem a generic approach is absolutely necessary. Without the aircraft models to reduce the baseline fleet to vehicle classes, the full-scope dynamic fleet-level modeling problem would be unmanageable. The problem would become even more unmanageable with the introduction of specific technology vehicles. Furthermore, only one airport model was used to represent the entire airport space. Generic Airport models could be leveraged to limit the variability in the vehicle class proportions and fleet-level process variables, significantly reducing the number of cases required to produce reasonable surrogates for certain airport types.

Another issue deals with properly exploring the aircraft design variable space, and propagating these impacts to the fleet-level. Not only must ranges and compatibilities in design ranges be set appropriately, but error-checking is also required to ensure that the fleet-level model is never utilizing failed cases, which would distort the accuracy of the predictions. Assuming that the vehicle-level space can be sampled appropriately, there is no need to combine these results in full factorial combinations as was done for this research. The full factorial combinations were utilized to ensure the utility of the cases executed was maximized to map the potential space. With more targeted and sophisticated vehicle-level DOE construction, the number of cases required to add technology aircraft for a given vehicle class could also be significantly reduced.

## 6. Conclusions

The research presented in [Bernardo 2014] provides a roadmap for creating fleet-level noise contour area surrogate models that capture vehicle-level technology factors along with fleet-level variables. The approach consisted of building layers of complexity into the surrogate models, utilizing a mixture-modeling framework, and introducing vehicle-level design factors as process variables. As the tests progressed, the quality of the surrogate models was assessed, and possible reductions in terms were explored. The major reduction in terms occurred in the modeling of the vehicle-level design variables and micro-mixture components affected by them. In parallel, fuel burn and NO<sub>x</sub> surrogate models were generated.

Once the fleet-level noise models were successfully developed, these were integrated with the fuel burn and NO<sub>x</sub> surrogates to produce a notional environmental tradeoff metric scenario. This proof-of-concept analyzed the potential for technology infusion in the SSA aircraft class to simultaneously reduce fleet-level noise, fuel burn, and NO<sub>x</sub>, assuming increases in operations between the baseline (2006) and a notional future forecast year in the 2030 time-frame. The results demonstrated that based on the notional underlying assumptions, the insertion of the technology vehicles could not overcome the increase in the environmental impacts due to increased operations. The SSA aircraft was chosen because it was expected to have the greatest impact to the mixture. Without complimentary improvements in the other vehicle classes modeled, a fleet-level reduction was unlikely, given the notional assumptions utilized. Nevertheless, the models constructed demonstrate the capability to simultaneously analyze each of the environmental metrics, and to visualize the competing trends between them.

While models were successfully generated and demonstrated for the scoped problem, the main purpose of the research was to determine the scalability of the approach. As vehicle classes are added to the mixture, and an expansion in vehicle-level variables is required, the basic techniques to properly sample the mixture-of-mixtures-process-variables space become invaluable in maintaining a manageable caseload. The

traditional mixture-DOE framework cannot support the construction of these models without the use of generic vehicle and airport models to serve as foci for the surrogate modeling process. Furthermore, without rapid noise prediction methodologies such as ANGIM, it would be impossible to provide appropriate sampling of the mixture-of-mixtures-process variable space. As cases are reduced, the runtime in such models is also reduced. The convergence of the two leads to the ability to produce more sophisticated models.

The need to link these environmental metrics is great, because it would allow the designer to examine simultaneously the three major environmental metrics, tracking vehicle-level changes directly to the fleet-level. This capability would also enable decision-makers to assess the potential sensitivities and gains that can be achieved with respect to technology versus operations. Without the ability to examine each of the metrics in the same environment, it is likely that decisions made intended to impact one metric could have negative implications for another. Such capabilities can improve the ability to select the appropriate technologies in the present that will yield the desired environmental improvements at the fleet-level to enable the projected increase in aviation operations. By increasing the number of technology combinations that can be analyzed at a preliminary stage, decision-makers can move forward with confidence that the technologies selected for further analysis and development are the most promising based on objective analysis. Making better decisions at this stage will ensure that large sums of money invested in these technology programs will yield beneficial returns to the aviation industry and the environment.

#### **4. A Multi-Stage Surrogate Modeling Approach to Examine Vehicle-Level Technology Impacts at the Airport-Level [Bernardo, Jan. 2015]**

Fleet-level analysis of technology scenarios are necessary to examine the system impact of potential technology packages applied at the aircraft level. Typically, fleet analyses require significant amounts of information to perform detailed model runs. This approach makes it difficult to analyze a broad set of technology scenarios because each one requires time consuming modeling. This paper presents a multi-stage

surrogate modeling approach capable of examining vehicle-level technology impacts to noise at the airport-level. This process was developed to provide a dynamic dashboard evaluation of vehicle-level technology rolled up to the system-level (a representative airport in this case). The approach defines a subset grid of data that are each treated like an individual noise metric at the aircraft level. Surrogate models are developed to represent aircraft-level noise at these locations as a function of aircraft technology and design characteristics. The subset grid is small enough that aircraft-level noise can be aggregated to the airport level almost instantaneously. Once at the airport-level a separate set of surrogate models utilizes the airport-level noise values to determine the location and size of the DNL 65 dB contour. The approach is described in detail, including generation of the surrogate models. Finally several notional scenarios are examined to evaluate the ability of the approach to represent the size and location of the DNL 65 dB contour as a function of aircraft-level settings.

#### *1. Background*

To dynamically assess the system-level environmental impacts of a broad technology space, surrogate modeling approaches have been applied. These consist of creating vehicle-level surrogate models for fuel burn and NO<sub>x</sub> emissions, as a function of vehicle-level technology factors. Once these surrogates are generated, a flight schedule can be used to compute a system-level aggregate in a rapid fashion, supporting dashboard-type tradeoff tools.

Unlike fuel burn and NO<sub>x</sub> emissions, which are evaluated at the fleet level by summing up the individual value of each aircraft, noise depends on both aircraft and airport specific characteristics. At the vehicle level, noise can be defined according to 4 subcategories: jet noise, combustor noise, turbo-machinery noise and aerodynamic noise. In addition to those sources of noise, many other factors are spatial and traffic specific. Airport-level factors are critical in order to assess the noise at the fleet level. Those metrics could be defined according to 2 subcategories: spatial factors such as the number of runways and runway orientation; and traffic factors including operations volume, fleet mix,

and distribution of operations across that fleet. The contribution of airport characteristics is unique and gives noise an unusually high dimensionality as it is scaled up to a fleet-level. As a consequence, it is very difficult to capture its behavior with a reasonable number of cases. Moreover, the other metrics track a total amount, while noise tracks the shape of the contour of a constant level of noise set by regulatory decree. Instead of tracking the amount, noise is tracking the size and shape of area exposed to at least a certain amount of noise. These characteristics make it extremely challenging to develop surrogate models capable of capturing the noise behavior at a fleet level as a function of aircraft-level design changes.

## 2. *Dashboard Requirements*

The higher-level objective that motivated this research was to assess the system-level environmental impacts of a broad technology space. The idea is to offer users the ability to set specific requirements at both the vehicle and fleet level such as on-board technologies or vehicle replacement schedules. This must be done in a dynamic trade-off environment to provide users with a fast and visual feedback about the scenario they defined. It is intended to offer users a 3D-preview of the vehicle geometry as well as multiple system-level metrics such as DNL contours, fuel burn and NO<sub>x</sub> emissions. Aircraft level impacts, geometry, and measures are obtained using EDS. [Jimenez Nov. 2012]

When developing such a platform, processing time becomes a high priority. If users have to wait more than a handful of seconds before obtaining forecasting results, it will inhibit their ability to perform rapid trades and ‘what-if’ scenarios. This speed of computation must be made possible not only for aircraft-level measures but also system-level measures. Processing efficiency of the models that integrate to form the dashboard is a key requirement. For noise specifically, the process that will be discussed must be able to compute the DNL 65 dB contour and its contour area in a time-frame that supports dashboard analysis. The ‘system’ defined for noise is slightly different than those defined for other metrics. Because noise is a local effect, the system will be modeled using a representative airport with a representative set of operational

characteristics. The airport will be modeled as a single runway airport in uni-directional traffic flow, supporting separated analysis of approach and departure contours without confounding results with geometric impacts.

Enabling these types of analysis for airport noise presents a unique challenge: to develop models that can determine, in nearly instantaneous time, the location and size of the DNL 65 dB contour given a set of aircraft noise characteristics that are not entirely known until the user provides definition. To address this unique challenge a novel approach is required, linking vehicle-level impacts in noise directly to the shape and location of the DNL 65 dB contour. The approach leverages previous experience in vehicle-level and airport-level noise surrogate modeling to create a combined approach. By linking these capabilities, the impact of vehicle-level technologies can be viewed in future forecast years of the fleet with respect to the contour area *and* shape.

### 3. *Current Rapid Airport-Noise Assessments*

Rapid airport noise assessments are handled using a number of potential tools depending on the organization performing the analysis. [Tetzloff 2009, FAA 2012, Hollingsworth 2011]. Fleet-level noise is generally tracked by selecting a system of airports, and computing airport-level noise exposure at those system-airports. While different tools provide different types of capabilities, ANGIM is selected for use here due to its availability and relative higher fidelity. [Bernardo May 205]

ANGIM works by making several simplifying assumptions about the noise responses that it chooses to analyze. First, all airports are assumed to be at standard day sea-level conditions. Secondly, all ground tracks (the 2-D projection of the flight path) are assumed to be straight-in/out for approach and departure respectively. These two assumptions enable the pre-calculation of aircraft noise using the modeling standards defined in Ref. [SAE 2012] and [ECAC 2005]. The information database for existing aircraft noise models can be found in [ANP 2012]. This pre-calculation of generalized static noise grids enables the definition of a flight schedule and an airport geometry, which ANGIM uses to call,

sum, and interpolate these grids to produce airport-level noise at the grid of observer points. With this grid, contours, contour areas, and other useful metrics can be computed. ANGIM provides a significant benefit over detailed analysis models in the arena of screening-fidelity scenario analysis, because it removes the specificity that causes runtime to increase exponentially.

ANGIM is relatively quick to execute, with recent performance improvements providing speed well beyond the figures quoted in [Bernardo May 2015]. ANGIM, like other rapid airport noise assessment models, is still difficult to connect to a dashboard process. The reason for this is that ANGIM must know the aircraft flying operations at the analysis airport ahead of time to define them in the flight schedule. The dashboard on the other hand, requires the ability to dynamically edit technology-infused aircraft and visualize the impacts at the contour level. In order for ANGIM to run in-line, it would require the generation of a pre-calculated aircraft noise grid for each dynamically defined aircraft design, followed by an ANGIM run that reads in the new aircraft grids. The grids are time-consuming to generate, largely due to the high number of grid points used to define the airport noise grid. This situation results in a fundamental disconnect between the desired dynamic qualities of the dashboard and the pre-defined flight schedules required by ANGIM.

A solution to the problem must be able to take an unspecified set of aircraft-level noise characteristics and mix them to the fleet-level rapidly. To do this would require a reduction in the number of points used to define the airport noise grid or airport noise contour. Furthermore, the desired output is the contour, not an airport noise grid, so the solution must be able to locate the DNL 65 dB contour and predict its size with a reduced set of points.

#### 4. *Approach*

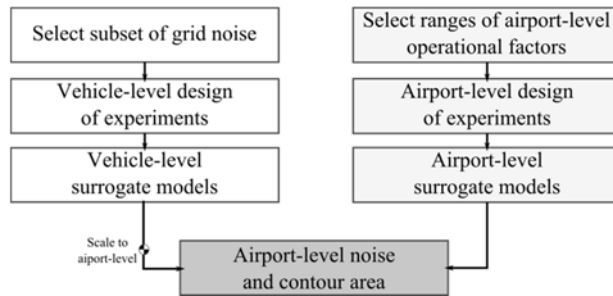
Given the requirements for a dynamic dashboard evaluation of vehicle-level technology aircraft impacts on airport-level noise, an approach was developed to enable a rapid real-time impact assessment of vehicle-level technology packages at the fleet-level. In order to

rapidly provide this linkage while allowing for contour area and contour shape computation, the approach employs several sets of surrogate models that are organized in parallel and in series to provide a solution that bypasses the time consuming aspects of aggregating explicit vehicle-level noise to the airport level.

The approach functions by first defining a grid of points that is relatively sparse (on the order of 100 points). These points are treated as individual metrics, much like total mission fuel burn, or total mission  $\text{NO}_x$ . The vehicle-level noise at these locations can be fit as a function of the aircraft-level technology and design parameters. The noise for all vehicles in the flight schedule can be aggregated to the airport level, providing Day-Night Average Level (DNL) noise values. Because the grid is comprised of only about 100 points, this aggregation can be done in real-time in the dashboard without significantly affecting the user. With these surrogate models in place, the noise at these grid locations needs to be connected to a set of surrogate models that define the location and size of the DNL 65 dB contour.

The main enabling assumption of the approach presented here is that the DNL 65 dB contour can be determined by a reasonably selected subset of grid points. Vehicle-level noise is tracked at this same subset of points, and is scaled to provide an airport-level DNL value at the subset of points, similar to the process ANGIM undertakes to compute airport-level noise. The approach treats local airport noise as a set of individual noise metrics (differentiated by spatial location) that combine to provide the contour shape and area. By generating airport-level noise models that are only functions of the combined DNL values at the subset of grid points, the models can remain robust to dynamic changes in vehicle definitions effected by the dashboard user. Similarly, by reducing the airport noise grid to a significantly smaller subset, scaling vehicle-level noise to airport-level noise becomes computationally feasible within the time-frame of a dashboard application. A summary of the approach is provided in Figure 91. The specifics of each step are outlined in [Bernardo, Jan. 2015].





**Figure 91 Approach summary. Vehicle-level and airport-level surrogates combine to predict vehicle-level impacts on the contour.**

Other important assumptions are required to complete the process in detail. The target airport-level model will be based on a single-runway airport in uni-directional traffic flow, with straight ground tracks. Using this configuration, the impact of aircraft-level decisions on approach and departure can be easily visualized in the context of other aircraft in the fleet. While one airport type will be discussed in this work, a subset of airport types could be modeled to model the diversity of impacts at different system airports. The diverse aircraft space will be treated through a vehicle class designation. The vehicle class designations are utilized to group aircraft into different ‘types’ reducing the number of unique aircraft noise models that must be used to assess airport-level noise. Each category will consist of a baseline representative aircraft, and technology variants introduced over time. Some of these variants will be dynamic, dependent on decisions made in real-time in the dashboard. A summary of the vehicle classes modeled, the representative aircraft, the number of tech variants introduced, and which are dynamic is provided in Table 17. The airport-level surrogate models developed are specific to a certain projected forecast year. Therefore, they are fixed with respect to the total operations (prescribed by the forecast year) and the macro-level vehicle class distributions. To further simplify the data collection and vehicle-level surrogate process, each vehicle class will operate at a representative stage length that is characteristic for aircraft of each type based on observed flight schedule data.

**Table 17. Vehicle class summary. Baseline models, tech variant enumeration, and dynamic designation.**

Vehicle Class	Baseline Model	No. of Tech. Variants		Dynamic (Y/N)
		2030	2050	

Turboprop (TP)	ATR-72	3	6	N
Regional Jet (RJ)	CRJ-100	3	6	N
Small Single Aisle (SSA)	737-600	4	7	N
Large Single Aisle (LSA)	737-800	4	7	Y
Small Twin Aisle (STA)	767-400	2	5	N
Large Twin Aisle (LTA)	777-200	3	6	Y
Very Large Aircraft (VLA)	747-400	2	5	N

Further details of the approach summarized here and implementation are discussed in [Bernardo, Jan. 2015].

### 5. Conclusions

The approach demonstrated in [Bernardo, Jan. 2015] provides a dynamic linkage between vehicle-level technology impacts and the effects of these impacts at the airport-level. The approach achieves this by trading off the number of observer locations at which noise is measured. Aircraft-level noise at these locations is predicted by surrogate models that are functions of the aircraft technology and design factors. All aircraft in the flight schedule can be aggregated using operations counts to an airport-level subset noise grid. Because these observer locations were selected strategically, they can be used to also locate and DNL 65 dB contour and predict its size using appropriate surrogate models. The structure of the design of experiments to collect that data to support the surrogate models was presented. The development of the surrogate models was then demonstrated, including a discussion on the potential impacts of uncertainty propagation caused by nesting surrogate models at different levels. Finally, the framework was demonstrated and compared against four appropriate oracle cases. The results show that the nested framework of surrogate models are providing accurate representations relative to the results that would be obtained by running ANGIM separately under the same conditions. Having demonstrated that the basic approach is working as expected, the value of a dashboard implementation is mostly dominated by the assumptions built into the models. Such assumptions include the number of representative airport models, the number of forecast years analyzed, the airport geometry, the airport traffic flow, the representative aircraft models used for each vehicle class, and the representative stage lengths

selected for each vehicle class. The models are only intended to provide a screening-level of fidelity for technology package assessment, and are not intended as replacements for ANGIM or more detailed airport-noise analysis models. However, the development of dynamic links between aircraft and airport noise enable modelers to instantaneously assess the impacts of numerous cases, providing more analytical information to support decision-making. It is likely that dashboard approaches such as these may require certain maintenance as users produce scenarios that may not be properly capture by the existing set of surrogate models. It is important to maintain this user-developer relationship to provide cases that stress the models to develop strategies for developing more robust sets of dashboard surrogate models.

Typically, predicting airport noise requires fixed aircraft noise models that are difficult to parameterize. The inability to parameterize the aircraft noise response grid precludes the use of rapid airport noise assessment tools. However, by leveraging combined surrogate modeling architectures, the link has been made dynamic, such that it can support dashboard-type analysis in conjunction with fuel burn, and NO<sub>x</sub> emissions. Assessing these environmental impacts in concert allow for a true tradeoff assessment for technologies that must be developed to enable the expected growth in aviation.

##### **5. Development of Generic Airport Categories for Rapid Fleet-Level Noise Modeling [Bernardo, Jun. 2015]**

Operations forecast are projecting significant growth in total operations in the United States and internationally. As a result there has been a concerted effort to identify technology options to reduce the environmental impacts of aviation including fuel burn, NO<sub>x</sub>, and noise emissions. To rapidly evaluate the impact of large sets of diverse and interacting technologies, a screening fidelity generic fleet-level approach to measuring environmental impacts is required. Fuel burn and NO<sub>x</sub> emissions are easily scaled to the fleet-level by generalizing specific flights by aircraft type and route distance. Noise requires airport-level analysis because it is a local and spatial effect. Unique modeling of specific airports does not suit the rapid simplified models of a generic

framework. This research discusses a process to create a set of generic airports by decoupling a subset of U.S. airports into their operational and geometric characteristic to perform grouping. The resulting models are demonstrated to provide an accurate system-level estimation of fleet-level contour area through a series of verification and validation tests. The resulting set of Generic Airports can be used to model the baseline set of airports, as well as to categorize other airports not considered for grouping.

Detailed fleet-level noise analysis requires creating airport-level contours for each airport included in any given study using a detailed tool such as AEDT. Performing this study includes a detailed AEDT model for each airport [Kish 2008, FAA Jul. 2014]. To provide rapid and simple airport noise computation, the Airport Noise Grid Integration Method (ANGIM) is employed for this research. ANGIM is based on the pre-computation of detailed vehicle-level noise grids under certain simplifying assumptions, which can be aggregated to produce airport-level noise contours [Bernardo, May 2015]. These assumptions include standard sea-level atmosphere, and straight ground tracks. ANGIM provides a more appropriate level of fidelity for computing fleet-level noise within the generic framework, as it does not require defining atmospheric characteristics, or unique ground tracks among other detailed airport factors.

#### *1. Research Scope*

The base collection of airports from which groups will be generated will ultimately impact the final group definitions, and will serve as the general classes to which other system airports are ultimately matched. The MAGENTA 95 will be utilized as this base set [Kish 2008, FAA Jul. 2014]. While the categories developed will be optimized to serve these airports, other U.S. or international airports could be included by assigning new airports to existing categories or partitioning extra categories.

For long-term fleet-level analysis, the two main variable categories of interest for this research are operational and infrastructure variables. Atmosphere is fixed in ANGIM, so utilizing these characteristics for

grouping would not be particularly useful. While there is important interaction between operational and infrastructure characteristics, they will be decoupled so that meaningful patterns can be identified. Examining the data-types that define airports operationally and geometrically suggests that searching for patterns within both variable categories simultaneously would be inefficient and unlikely to lead to relevant results. For example, while Los Angeles International Airport (LAX) and Pittsburgh International Airport (PIT) both have four runways, LAX is a major international port with more operations than PIT. When defining characteristics do not sufficiently correlate with each other, it can lead to difficulty in producing effective groupings.

The operational characteristics such as operations volume, fleet mix, and flight distribution constitute a grouping that results in generic runway-types.<sup>1</sup> The geometric characteristics such as the number of runways and runway orientation result in generic infrastructure-types. Decoupling infrastructure and operational aspects are similar to the approach utilized in [Bock 2001].

The decoupling of these two variable categories allows the airport noise contours to be viewed from two separate perspectives. Operational characteristics influence the bulk noise produced by the airport, dominated by the total number of flights, the types of aircraft operating, and the types of routes flown. Infrastructure characteristics, on the other hand, significantly influence how the bulk noise is allocated geospatially, particularly under the modeling assumptions made in ANGIM. Reflective of this decoupling, the sections in [Bernardo, Jun. 2015] address operational variables and infrastructure variables separately, as summarized in Figure 92.

More information on these steps, implementation and discussions are given in [Bernardo, Jun. 2015].

---

<sup>1</sup> The term ‘generic runways’ is applied because the operational characteristics provide enough information to define noise on a single-runway configuration.

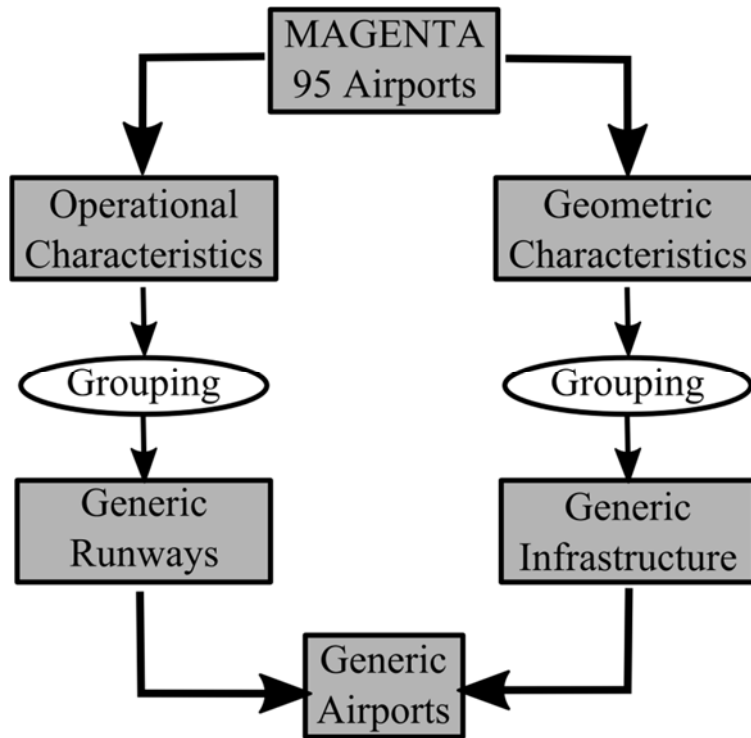


Figure 92 Summary of airport grouping strategy.

## 2. Conclusions

The results of developing generic airports presented in [Bernardo, Jun. 2015] yielded a set of models that support a generic framework for fleet-level environmental analysis. These generic airports can be used to infer noise-specific trends about airports, by simply analyzing the generic version, while saving runtime in early fleet-level airport noise analyses. Generic airports were constructed by decoupling the operational and geometric characteristics, and grouping within these separate characteristics to produce generic runway and generic infrastructure models respectively. Generic runways were created using operational data to group airports by total operations, and vehicle class distribution of flights. Generic runways were then verified to ensure that the mathematical model behaved as expected, and were validated, with respect to fleet diversity and variation in operational scenarios. The generic runways demonstrated that they can predict the baseline fleet-level DNL 65 dB contour area of the MAGENTA 95 sample airports, and preserve trends and accuracy due to a random forecast. Generic infrastructures were created by gathering geometric data, such as actual

runway layout, and resulting contour geometries to create reduced effective runway layouts. These effective geometries were observed and qualitatively categorized to yield seven generic infrastructures. Baseline generic infrastructures were used to examine the direction required for calibration, while a configuration exploration was utilized to define the mode of calibration for each generic classification. Calibration was then performed yielding generic infrastructures capable of accurately predicting the fleet-level DNL 65 dB contour of the MAGENTA 95 airports. Twenty-eight generic airports were then constructed by joining the two components, and similarly shown to provide sufficiently accurate in-group and total predictions of the DNL 65 dB contours for the 95 sample airports.

The categorization of airports was identified as a necessity within a generic framework for fleet-level assessment of aviation because of the inefficiency of calculating a large number of unique airports when performing a fleet-level study. Because noise is a spatial problem at its core, the airport-level cannot be bypassed when generating fleet-level estimates without risking significant inaccuracy. By creating a set of generic airports, only a handful of airport-level noise scenarios are required to approximate fleet-level measures. This reduction in airports allows for a more rapid analysis of the impacts of technology packages on noise, in conjunction with the other environmental metrics.

## **5. Results**

This section contains the results of the fleet level analysis. It should be noted that the dashboard allows the user to reproduce these results given matching assumptions as inputs. Over the period of performance for this effort a number of different results were produced. These were based on updated data as it became available. This ranged from new, updated, and improved vehicle level estimates of environmental performance to updated forecast data. The results shown here represent the best estimates that were available at the end of the period of performance. In some cases, prior results are also shown in order to

illustrate the amount of changes that were the result of repeating the analysis with updated data.

## **1. Fleet Level Results**

### **1. Scenario Fuel Burn Results**

Figure 95 shows the projected jet fuel used on an annual basis by airlines in the US including domestic flights and international flights leaving the US. The specific scenario “Business As Usual” refers to the assumption that no new technologies beyond what currently is in production is introduced in the future. This represents an extremely pessimistic scenario, but nevertheless is useful as a relatively neutral reference scenario that can be used as a guide as to how much additional vehicle technologies will potentially reduce environmental impacts. The three results shown in this scenario show the impact the updated aviation forecasts that were released in the last several years have. The difference in the near future is relatively small, but grows much more significant the farther into the future aviation is projected. This is especially important if goals as far out as 2050 are being considered for aviation.



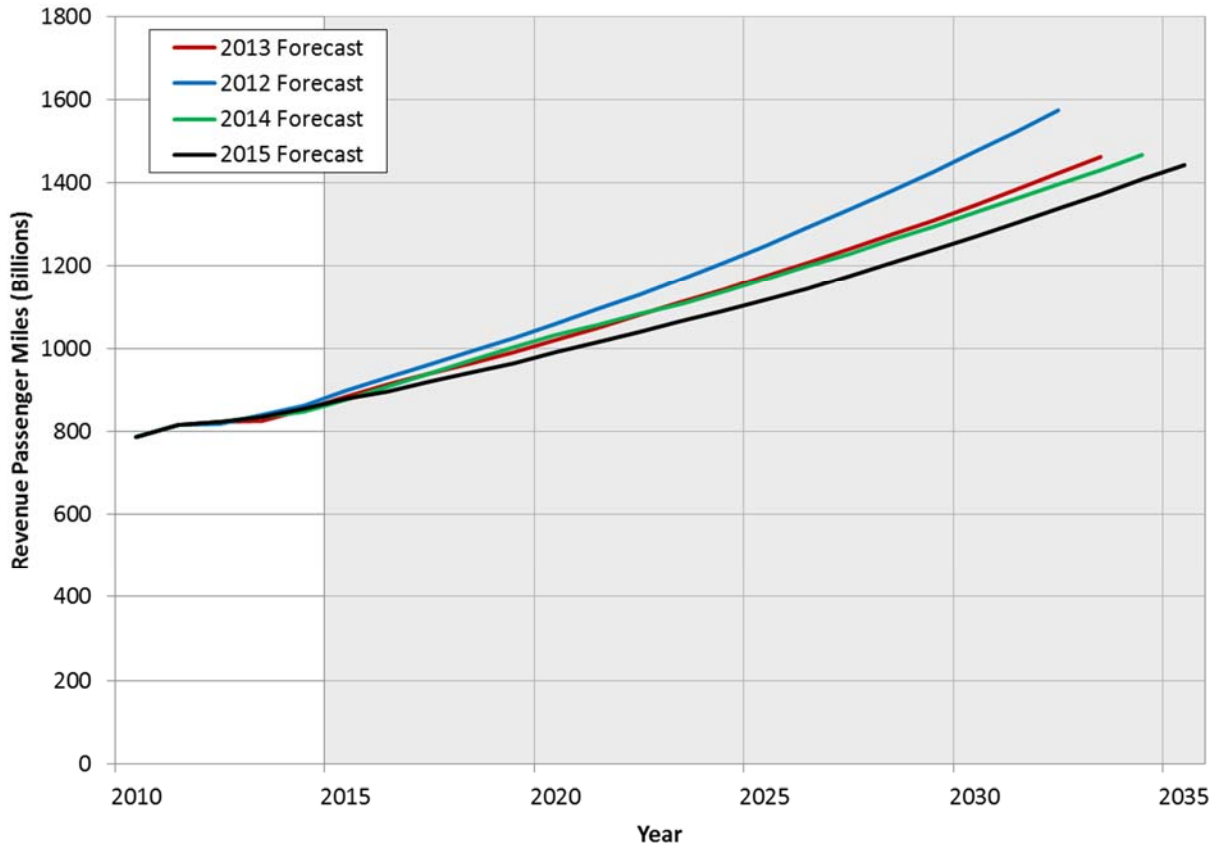
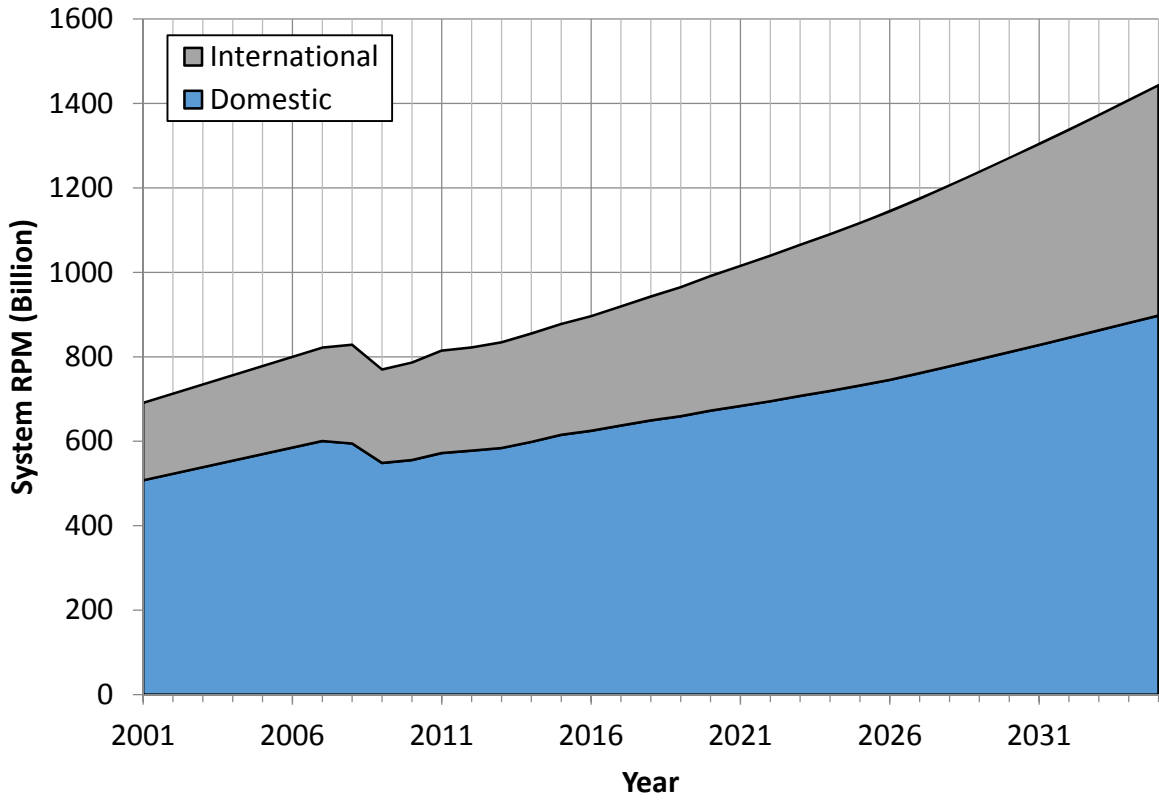
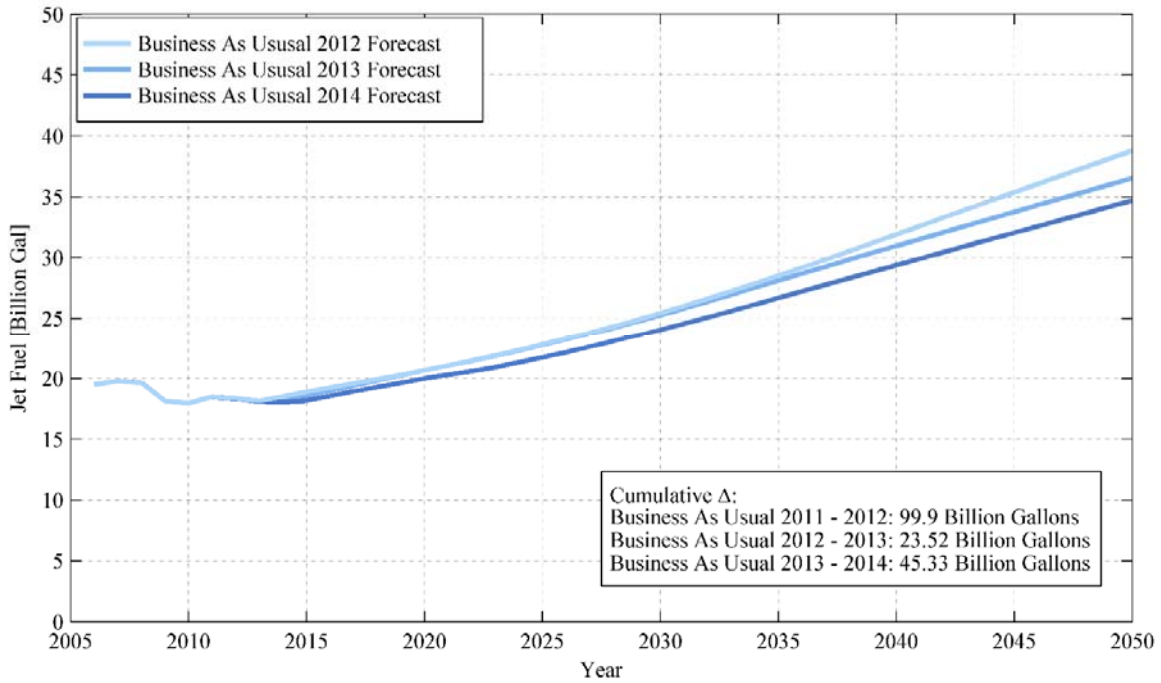


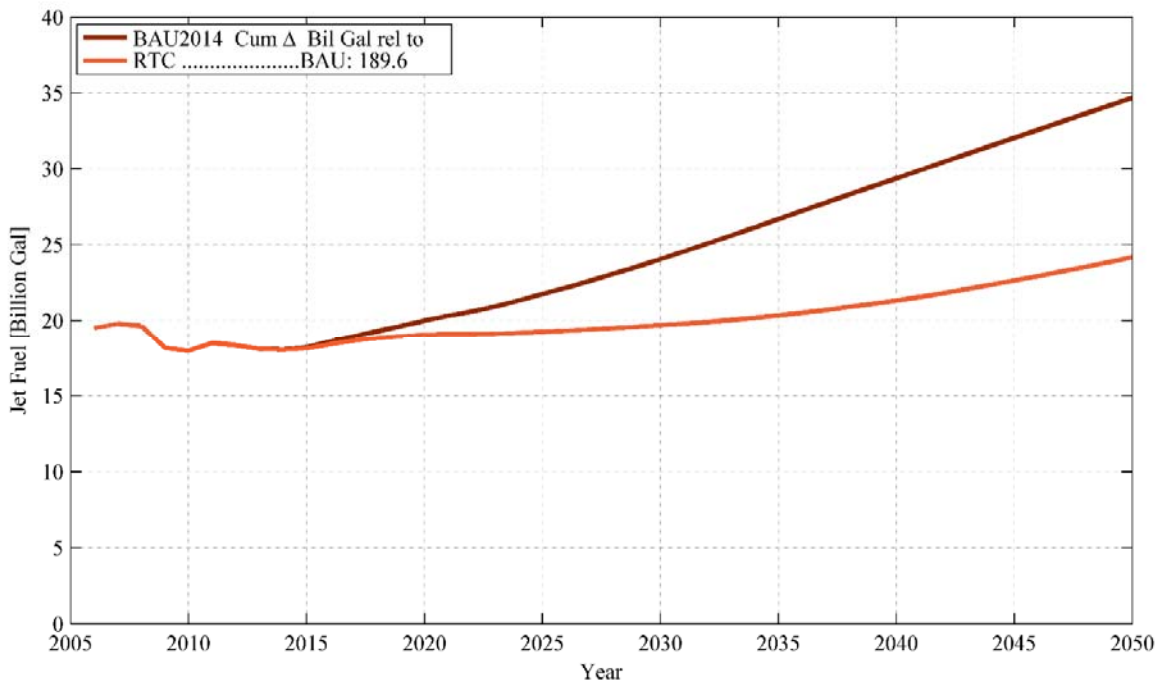
Figure 93 FAA Forecast changes in RPM



**Figure 94 FAA domestic and international forecast in system RPM**



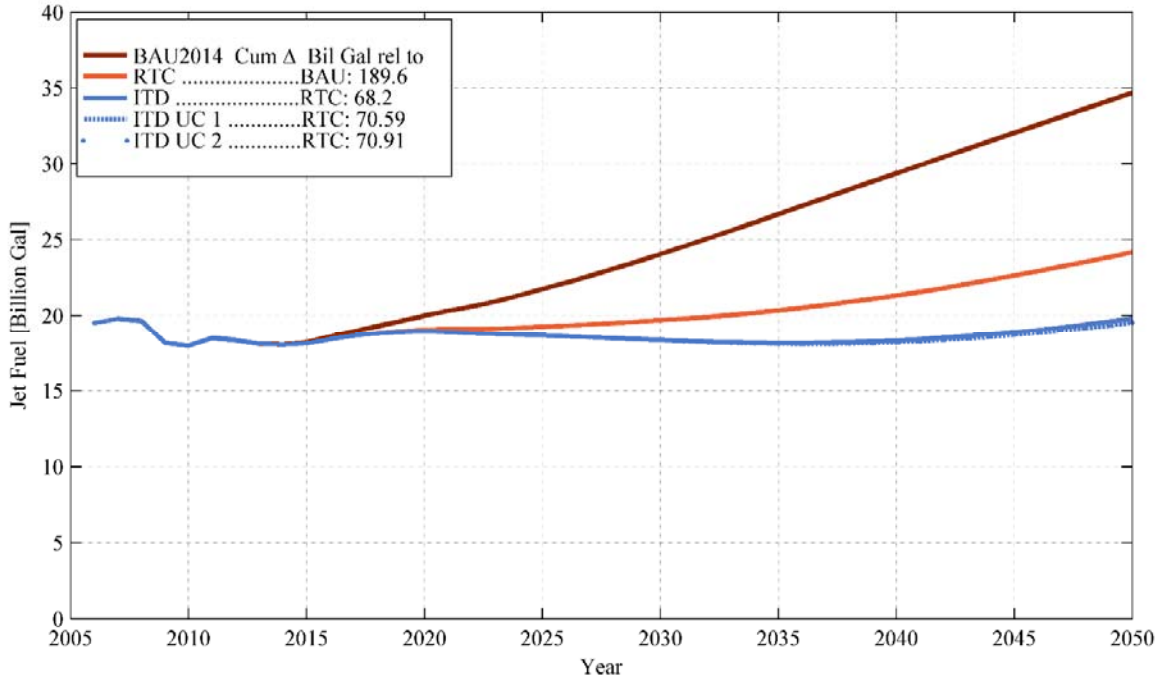
**Figure 95 Business as Usual Comparison of Fuelburn with different Forecasts**



**Figure 96 Comparison of Business as usual to Reference Technology Collector in terms of fuel burn**

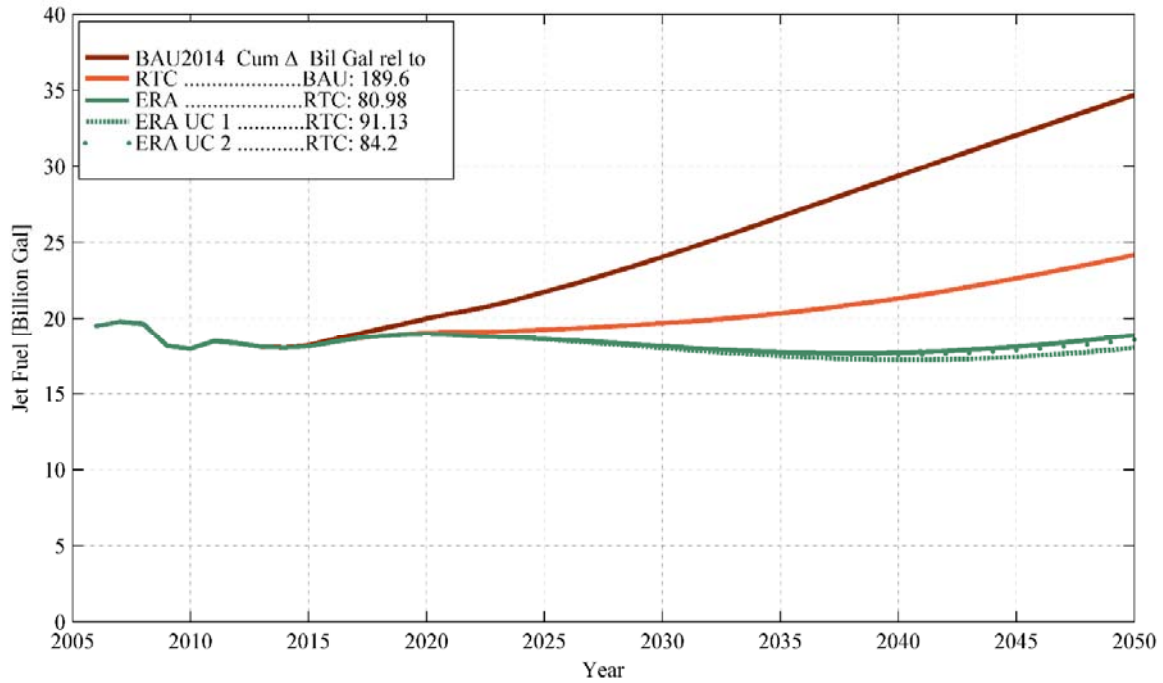
Figure 96 shows the overall trajectory of the RTC scenario as defined above and the cumulative savings relative to the BAU scenario

over the forecast period. This represents the fuel savings due to upgrading the entire fleet to a roughly current level of technology while retiring out of production aircraft.



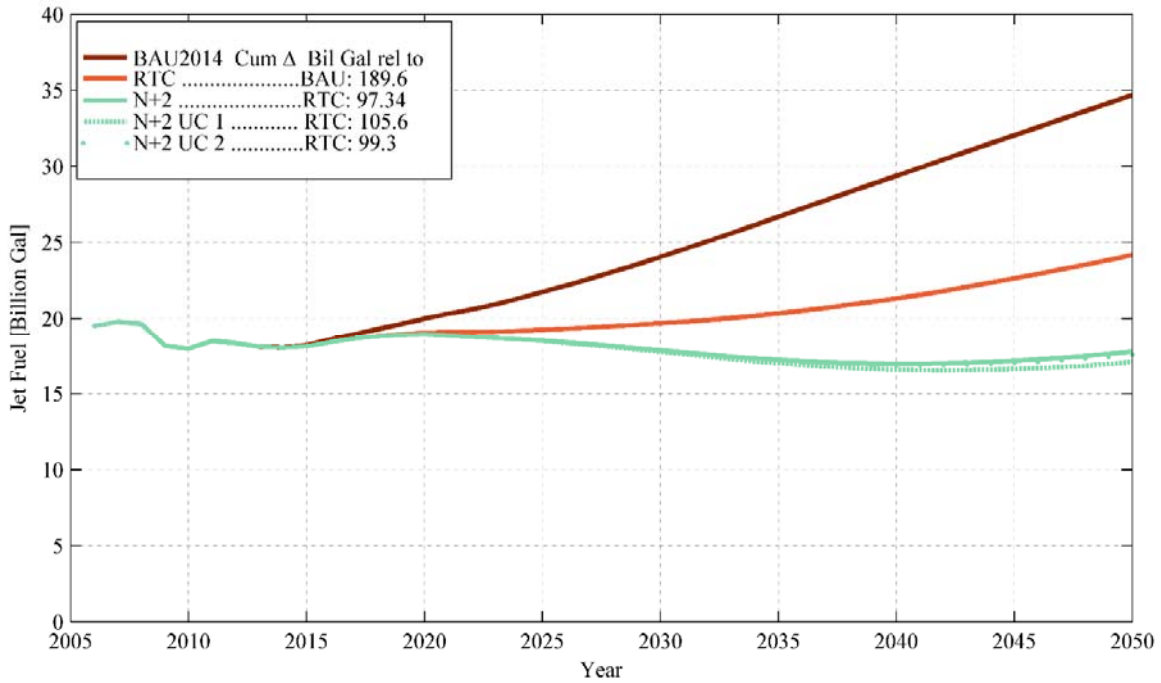
**Figure 97 Comparison of ITD scenarios in terms of fuel burn**

Figure 97 adds the conventional ITD technology scenario to the results.



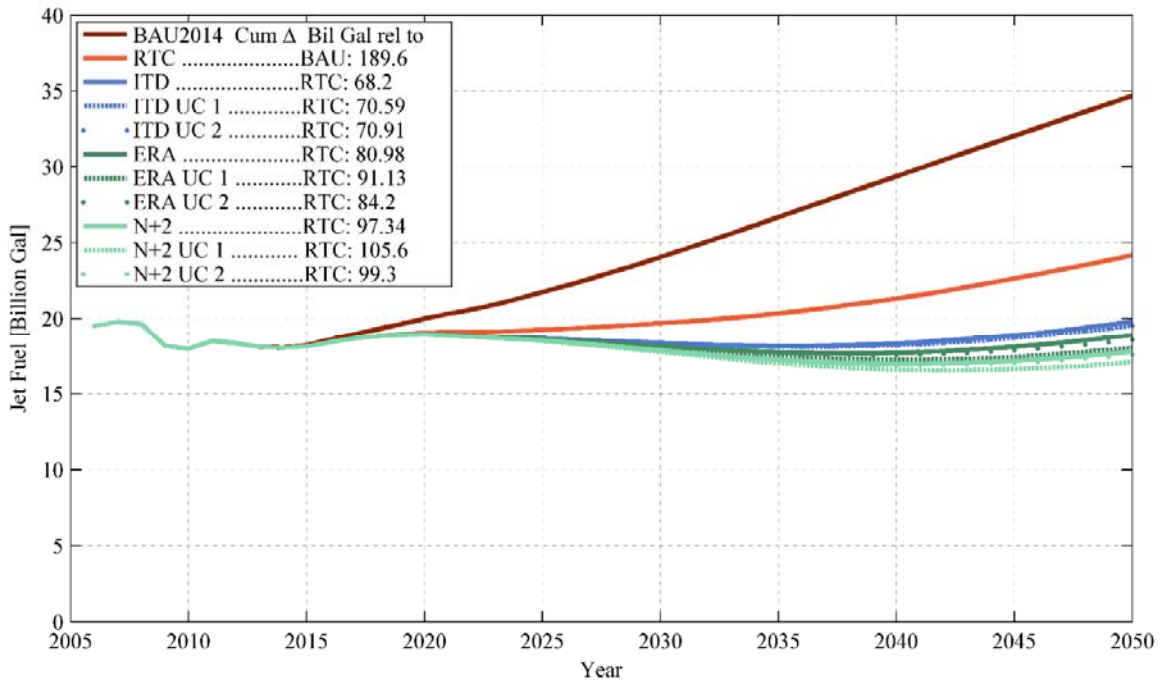
**Figure 98 Comparison of ERA scenarios in terms of fuel burn**

Figure 98 shows the relative comparison of the ERA technology set related scenarios across a number of only conventional tube and wing concepts as well as fuel burn and noise reduction optimized unconventional concepts. It should be noted that the relative overall saving are relatively modest.



**Figure 99 Comparison of N+2 scenarios in terms of fuel burn**

Figure 99 shows similar trends to the previous figures. However, the overall saving compared to the reference scenarios are increased, because this represents the most aggressive technology set considered.



**Figure 100: All fleet scenarios in terms of fuel burn**

Figure 100 repeats the previous results but shows all scenarios in a single chart together. The lowest fuel burn scenario is the fuel burn optimized unconventional scenario with the most aggressive technology set (N+2 UC1).

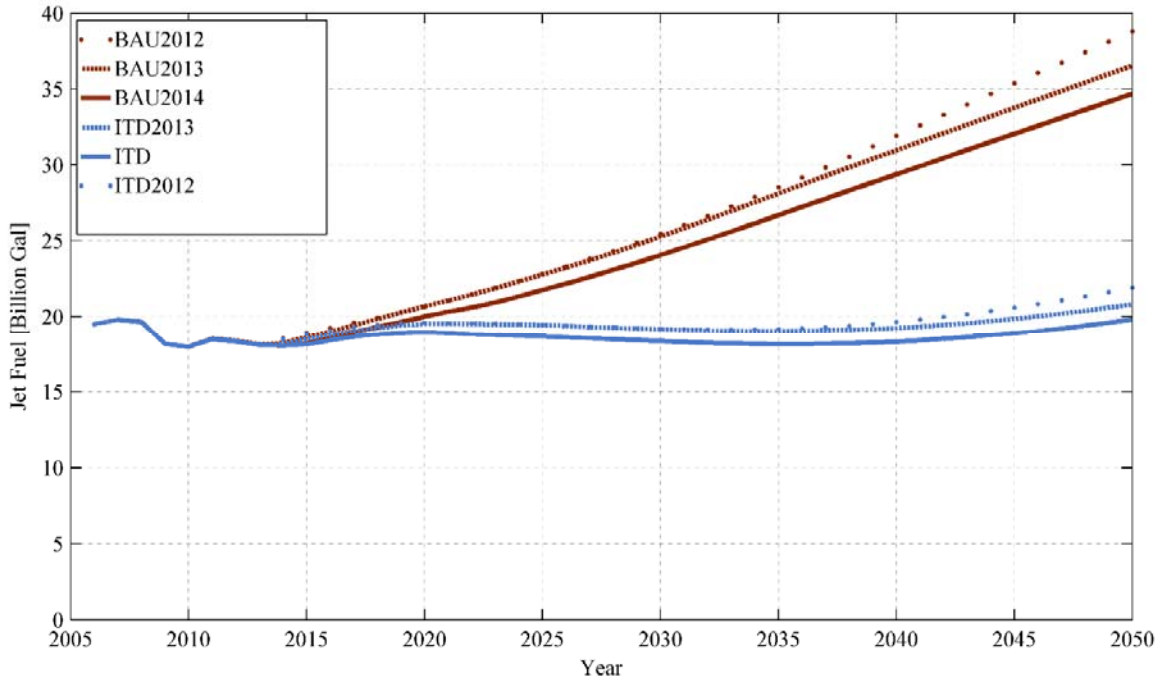


Figure 101 Comparison of forecasts and vehicles in terms of fuel burn

Figure 101 shows the comparison of prior scenario analyses with prior forecast as well as prior vehicle performance data. This shows that the forecast still remains one of the largest factors of uncertainty, while the changes in the vehicle performance estimates were relatively stable.

## 2. Scenario Total NOx Results

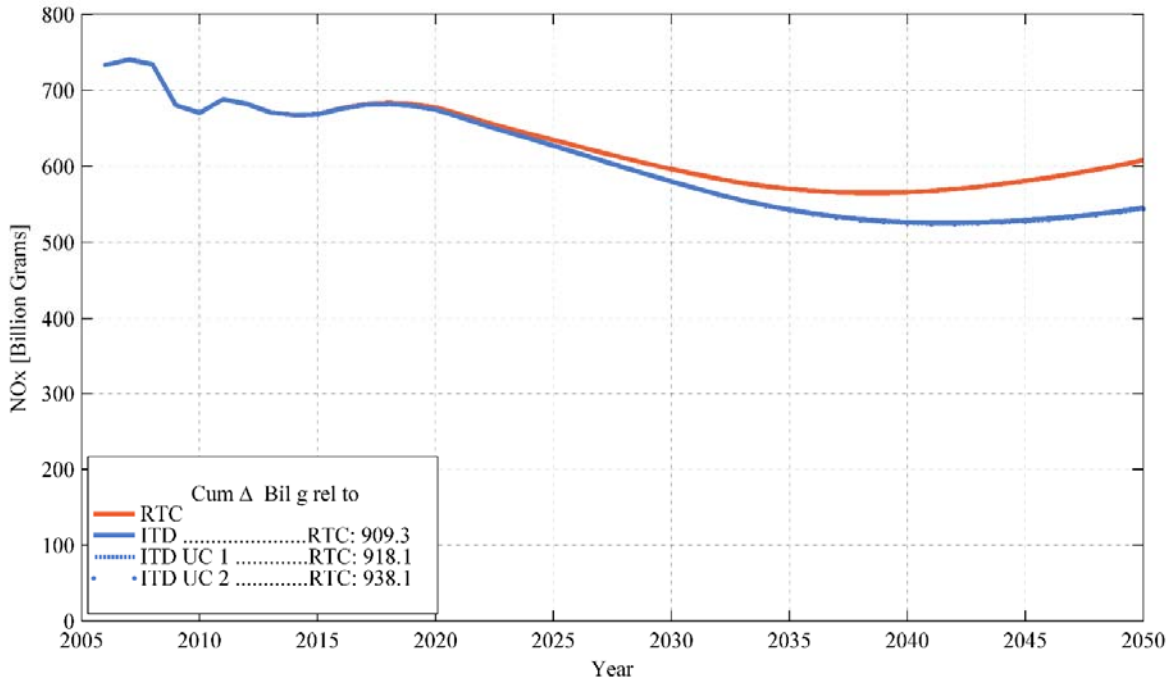
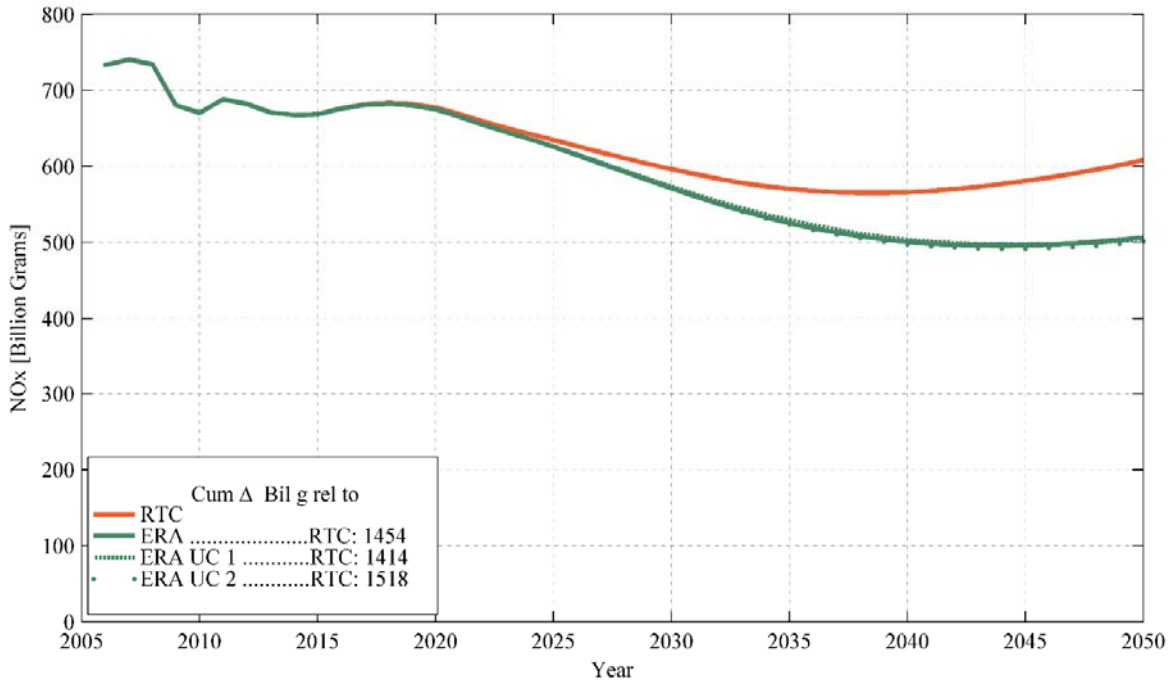


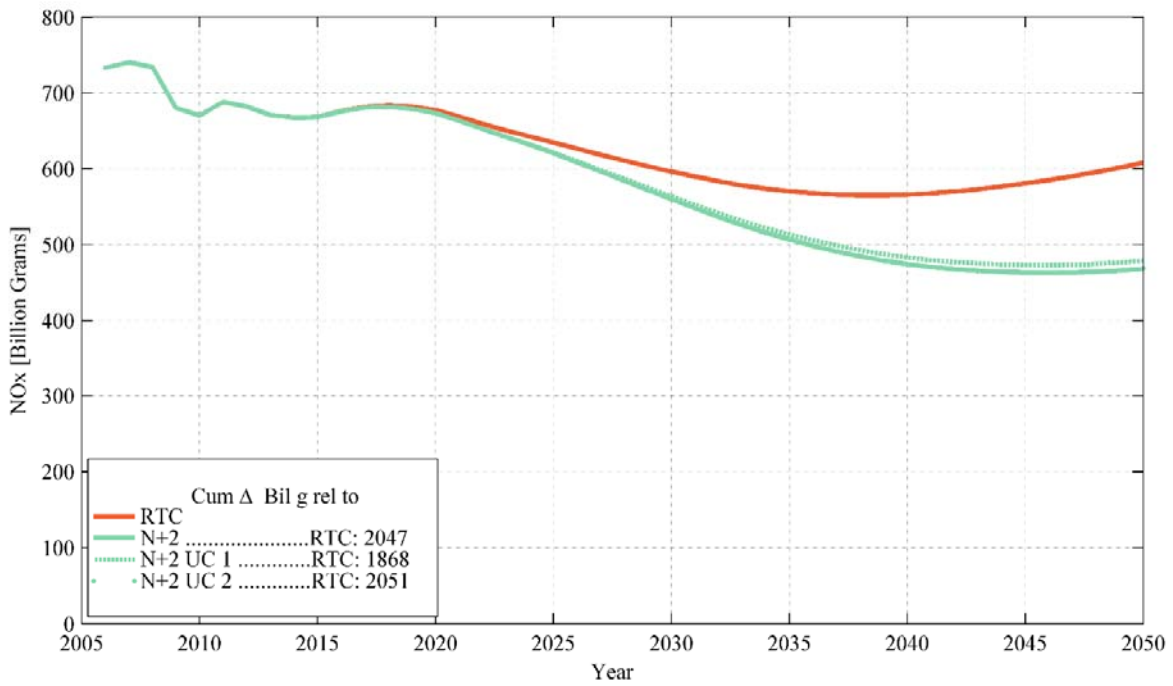
Figure 102 Comparison of ITD scenarios in terms of NOx

Figure 102 shows the comparison of the overall NOx emissions. It should be noted that the per vehicle reductions are often stated in terms on relative engine improvements compared to the certification requirements. The certification requirements however scale with overall pressure ratio and do not directly translate to the absolute level of emission reductions shown here. Still it should be noted that significant reductions are possible even while the forecast contains a large increase in traffic.

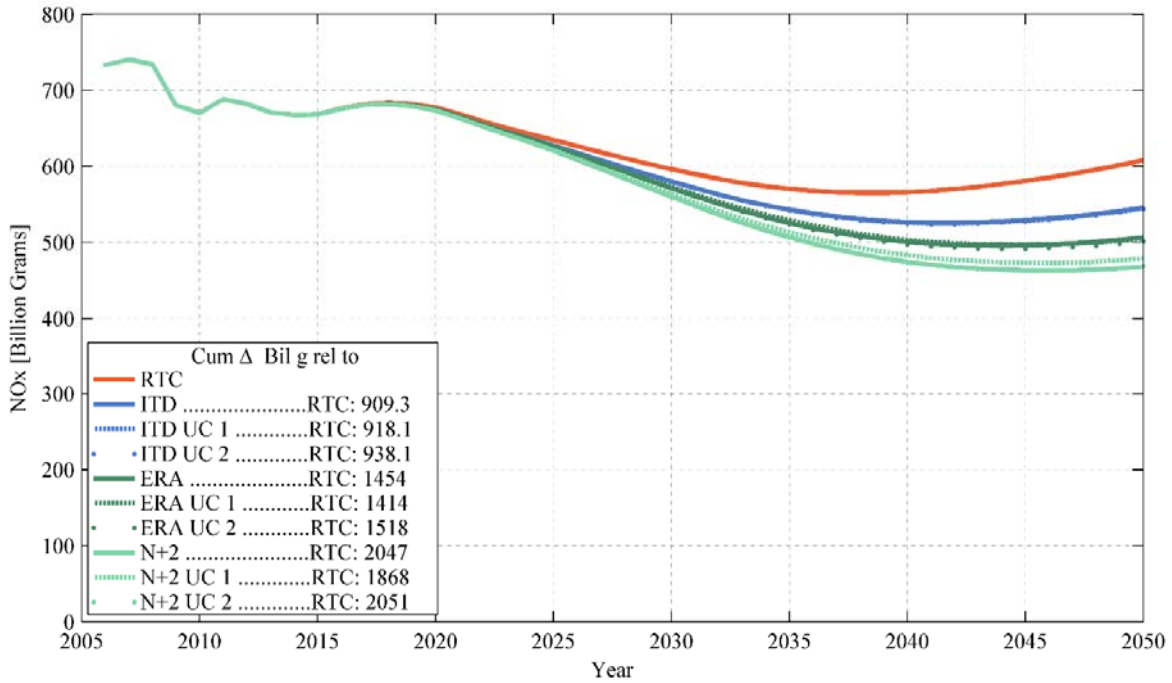




**Figure 103 Comparison of ERA scenarios in terms of NOx**



**Figure 104 Comparison of N+2 scenarios in terms of NOx**



**Figure 105 All Scenarios Fleet Level Total NOx**

Figure 103 to Figure 105 show the comparison of all scenarios with the different sets of technologies. Again the lowest total NOx scenario is N+2 UC2, which is the noise optimized unconventional configuration scenario with the most aggressive technology scenario.

### 3. Scenario Local NOx Results

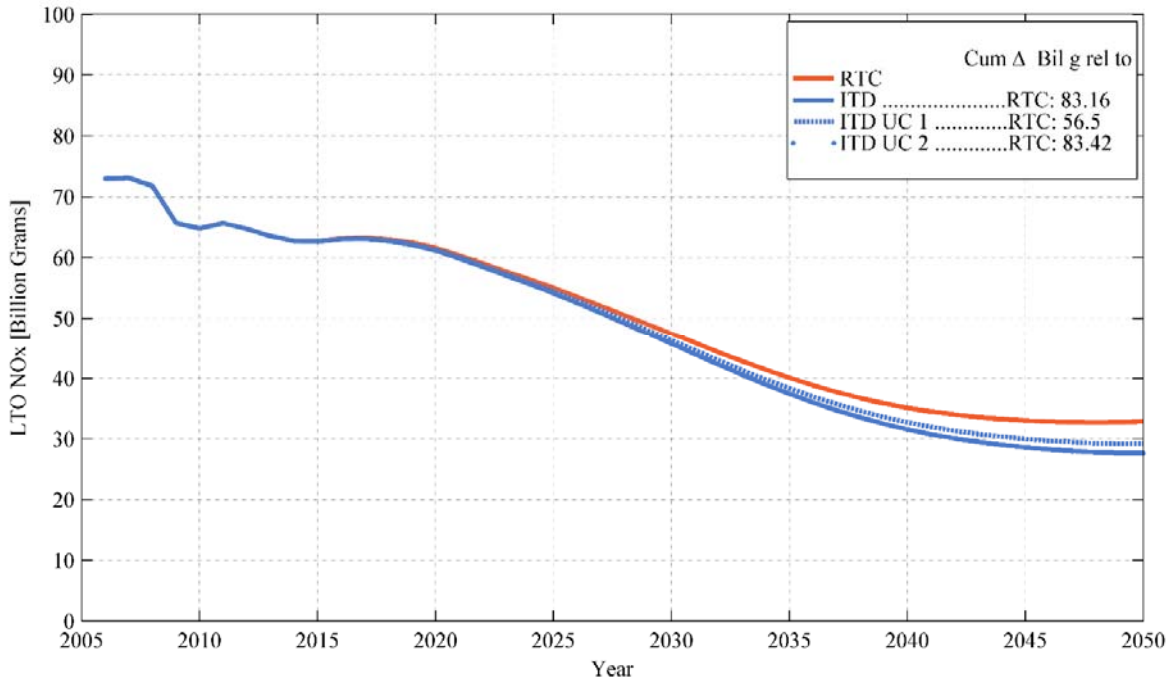
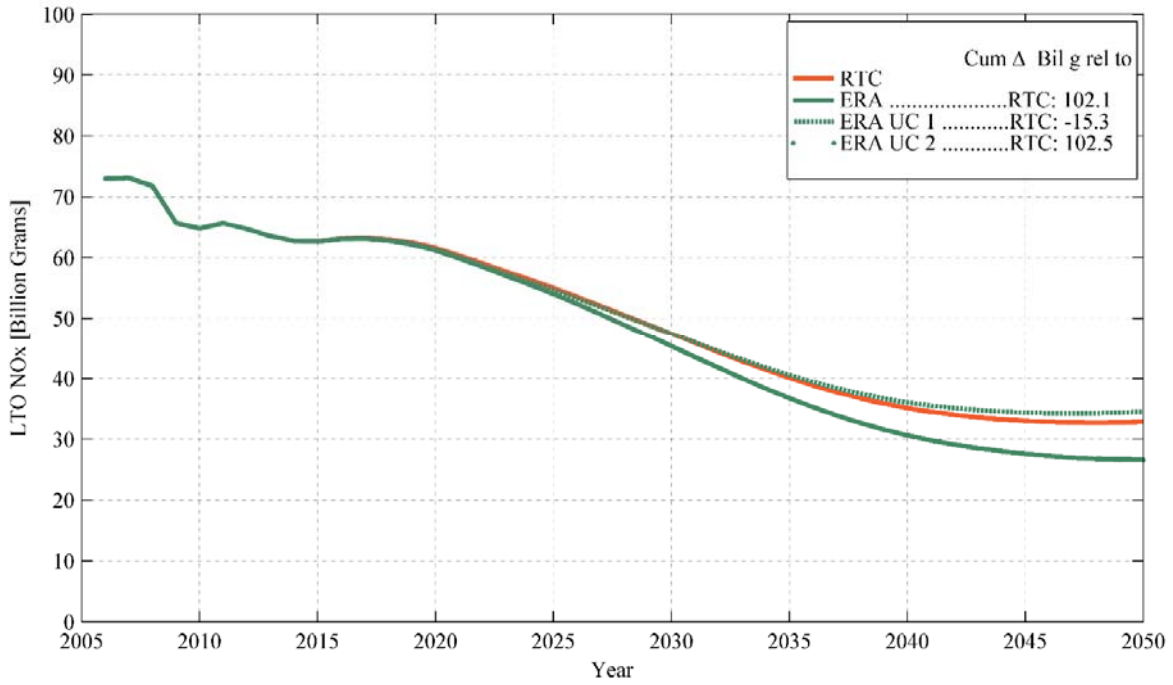
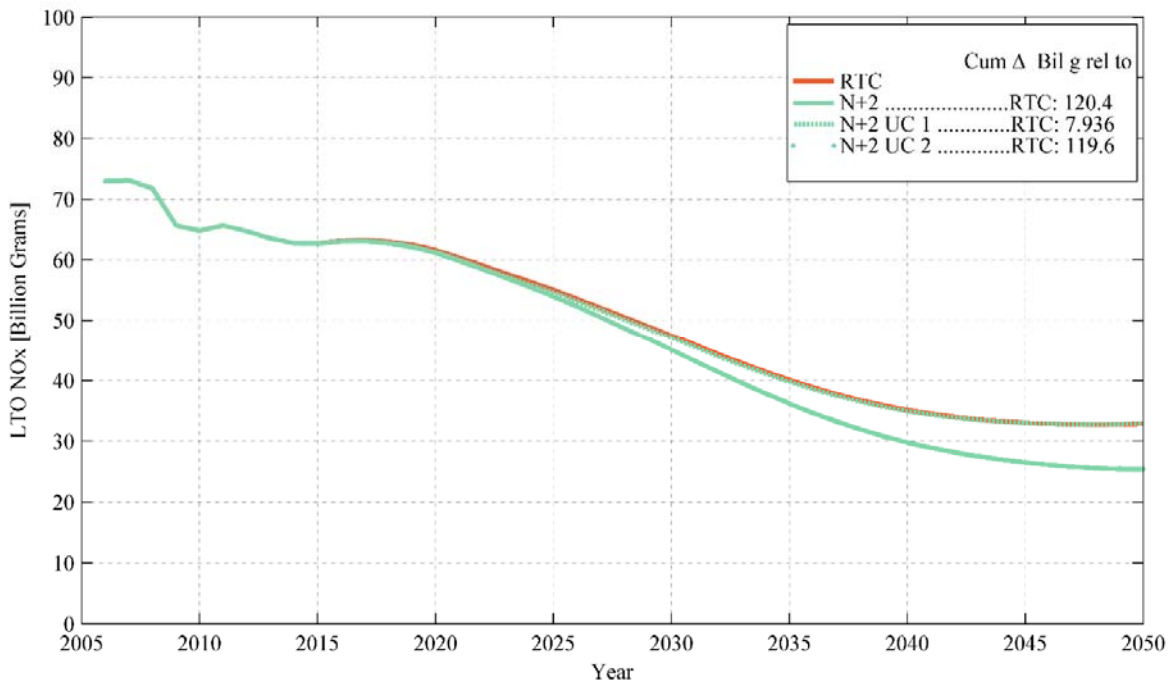


Figure 106 Comparison of ITD scenarios in terms of local NOx

Figure 106 shows the local NOx emissions as compared to the total NOx emissions shown before. Local NOx represents the NOx emissions below 3000 ft above ground level which have been shown to be the emissions that impact the local concentration of what can affect people's health the most. Compared to the overall emissions this represents only roughly 10% of the total. The rest of the NOx emissions happens at levels above this threshold and represent higher altitude emissions. It shows that even current technology scenarios decrease the local emissions significant in the face of a large increase in aviation activity.



**Figure 107 Comparison of ERA scenarios in terms of local NOx**



**Figure 108 Comparison of N+2 scenarios in terms of local NOx**

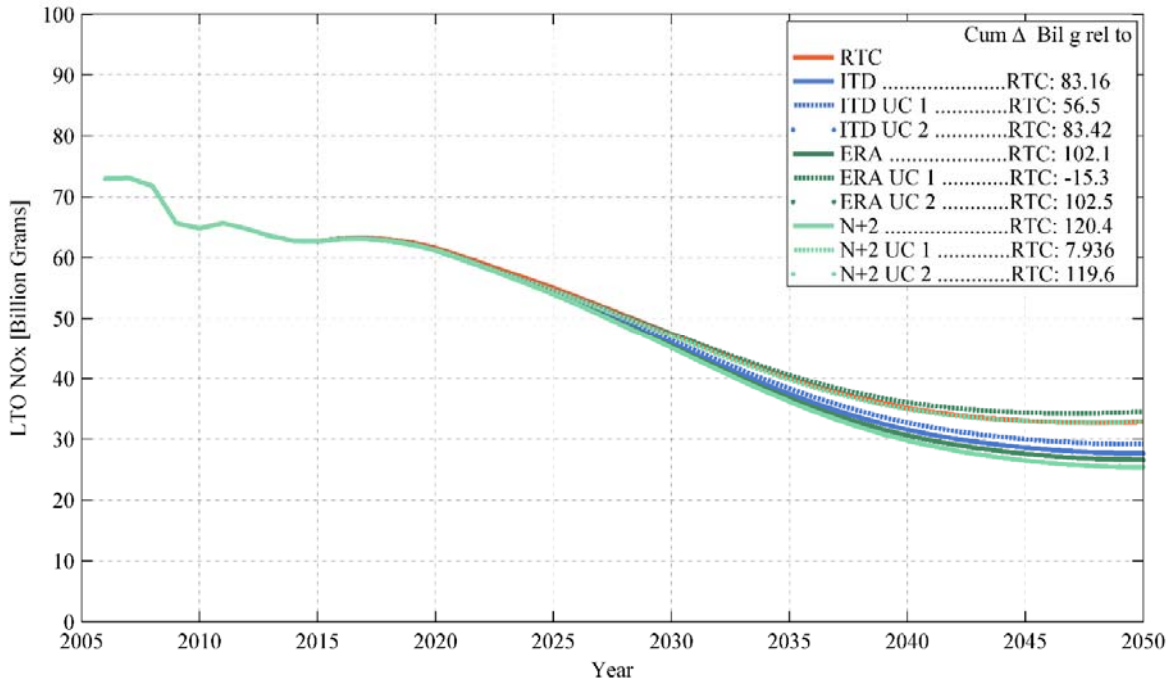


Figure 109 All fleet scenarios in terms of local NOx

Figure 107 to Figure 109 show the comparisons of the various technology scenarios. It should be said that these results are primarily dependent on the combustor modeling assumptions, shown in the vehicle modeling effort, as well as choosing the engine operating behavior in off-design conditions such that it minimizes emissions. As such there is some variability in the results shown, since there is experience yet to be gained in how to operate a new engine architecture (such as the open rotor) in off-design conditions in order to minimize emissions in those conditions.

#### 4. Scenario Noise Results

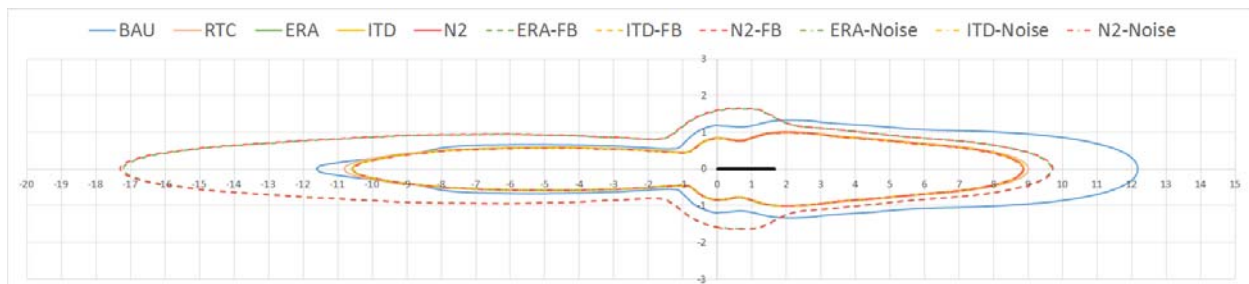
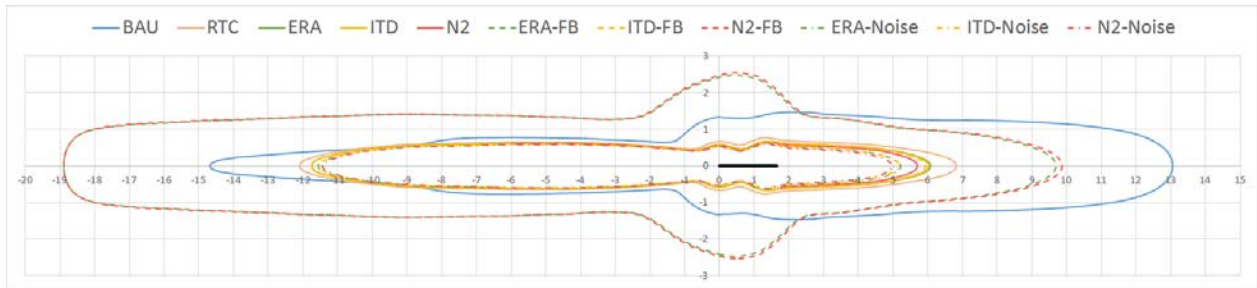
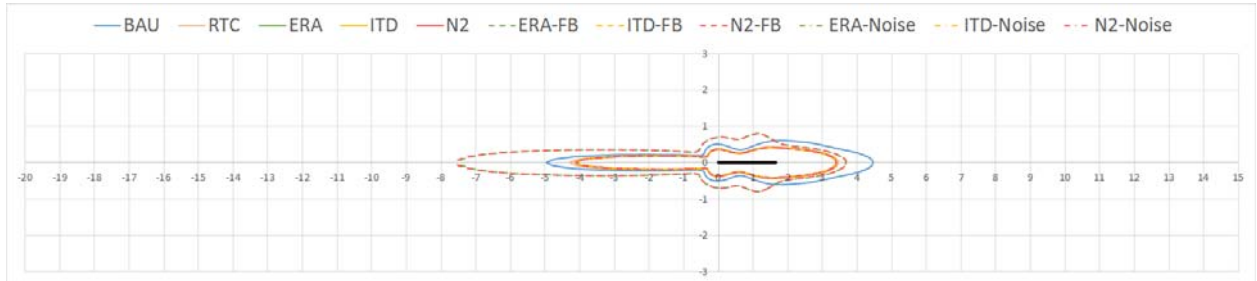


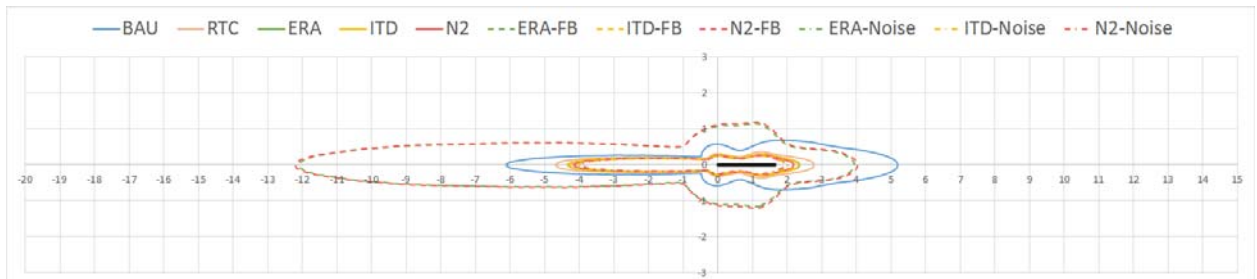
Figure 110 Medium airport 55 DNL contour for 2030



**Figure 111 Medium airport 55 DNL contour for 2050**



**Figure 112 Medium airport 65 DNL contour for 2030**



**Figure 113 Medium airport 65 DNL contour for 2050**

Figure 110 to Figure 113 show the estimated DNL contours at 55 and 65 dB levels for the various scenarios. It should be noted that the airport is a simulated single runway airport with unidirectional flow from left to right. The black bar in the middle represents a 10,000 ft runway. Therefore, the left side represents the approach side of the estimated contour and the right side the departure side of the contour. The assumed fleet mix is derived from averaging several medium size airports forecast traffic that represents a good mix of domestic and international flights with good coverage across all sizes of aircraft in order to better capture the overall effect of noise improvement technologies across all aircraft. The N+2 noise optimized unconventional configurations show on balance the smallest contours, whereas the fuel burn optimized variant is significantly larger. This

shows the magnitude of the trade-off that exists between various unconventional configurations.

### 5. IDEA Results

Finally, the technology scenarios described were run through the IDEA tool. This was done in order to capture the effects of technology with an additional set of scenarios containing either high or low fuel prices. The result of this is shown in Figure 115, which shows the relative demand and ticket prices for these two variants given the BAU scenario with low technology introduction.

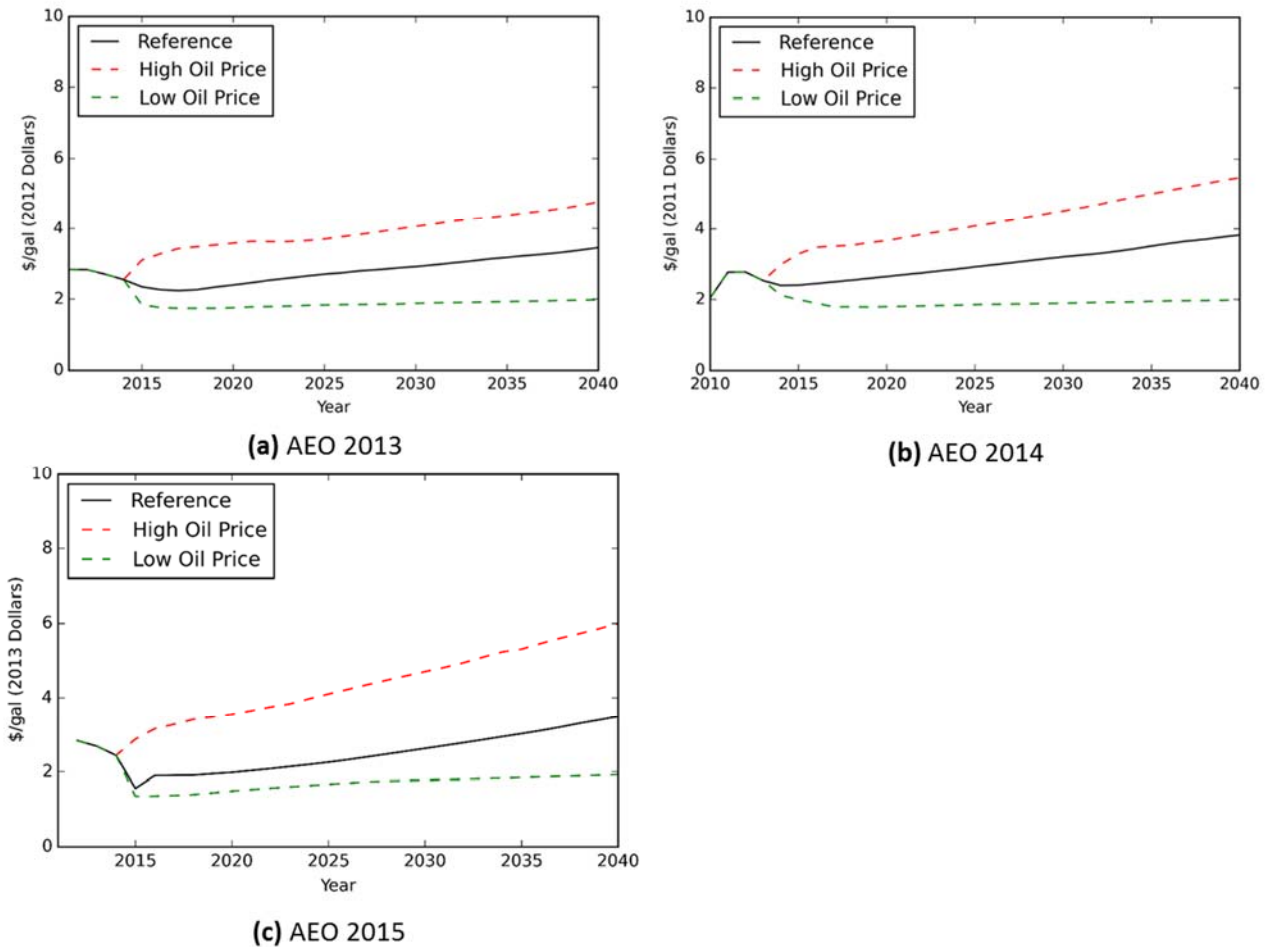


Figure 114 EIA Annual Energy Outlook (AEO) jet fuel price

Figure 114 shows the fuel price scenarios explored with this model.

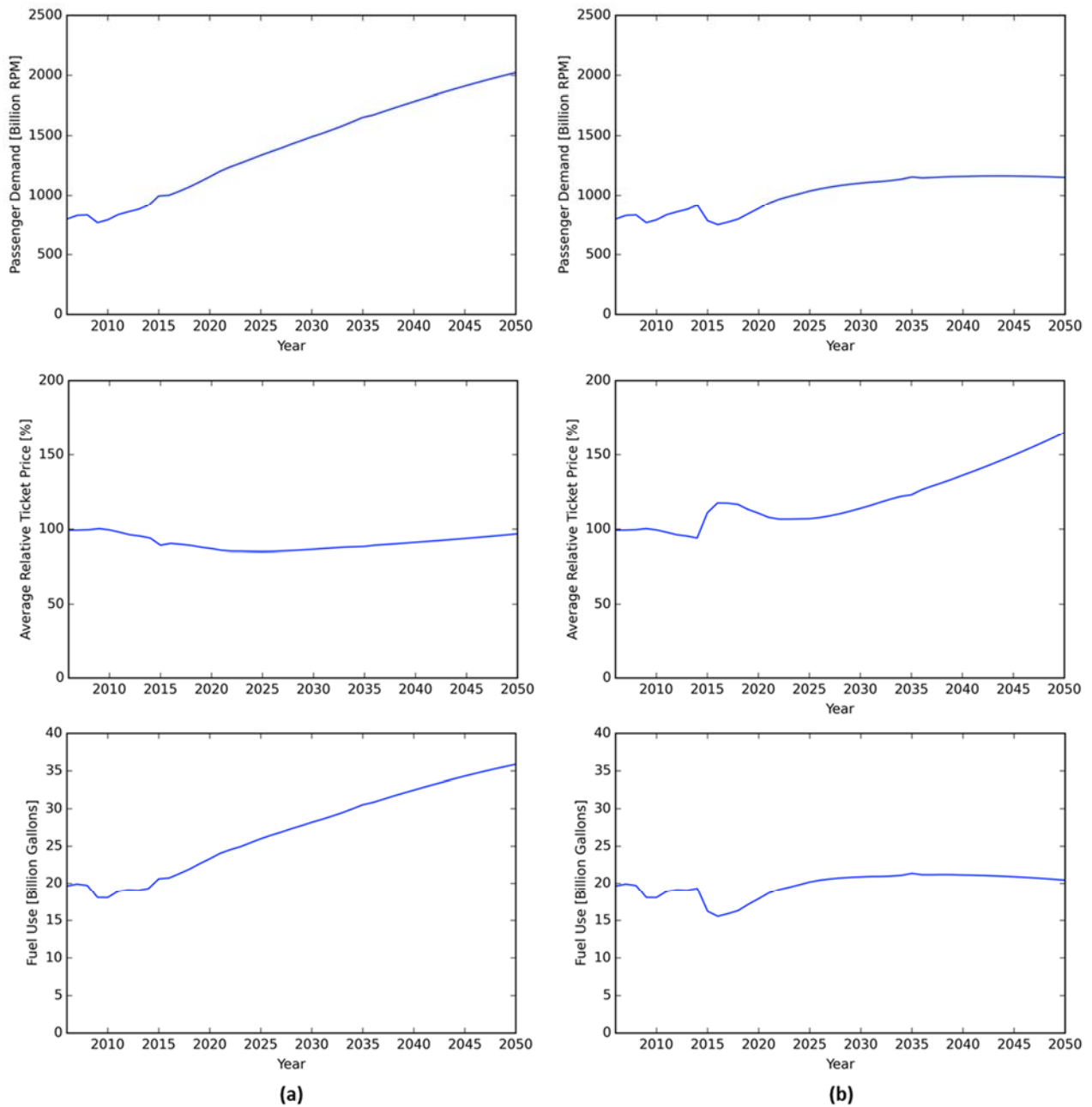


Figure 115 Low technology (a) low fuel price; (b) high fuel price scenarios

Conversely, Figure 116 shows the same data for the most optimistic fuel efficient technology scenario. The results show that low technology adoption will actually subdue demand and therefore lessen the impact of inefficient technology in term of overall fuel use. However, conversely, the adoption of very efficient technologies will actually increase demand somewhat by making air travel cheaper and therefore reduce the benefits



of the more efficient aircraft somewhat and have slightly higher fuel use due to higher demand that would otherwise be expected. This illustrates the dynamic effects of the technology portfolios that can be expected in aviation given variations in external cost parameters such as the fuel price.

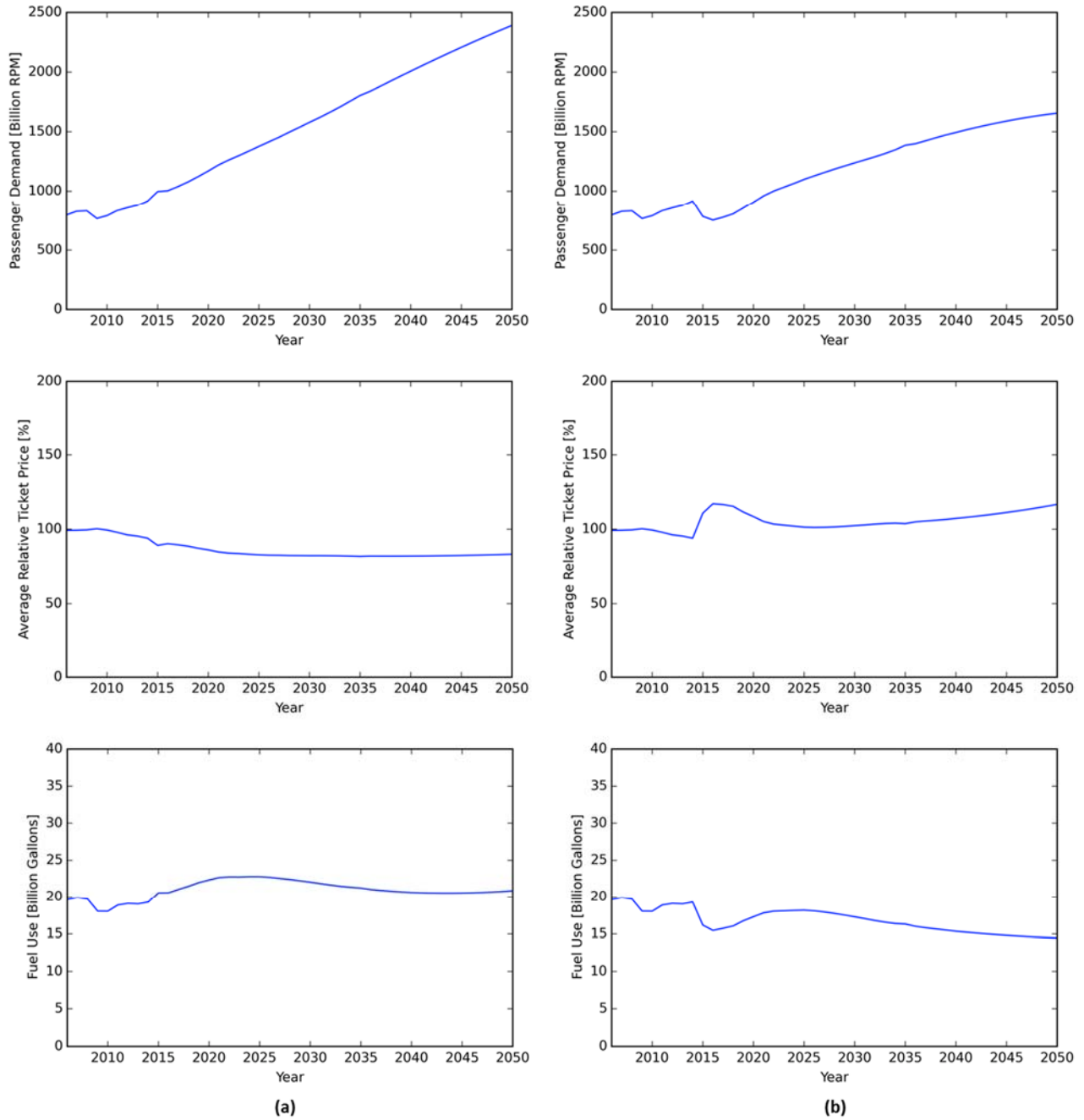


Figure 116 High technology (a) low fuel price; (b) high fuel price scenarios

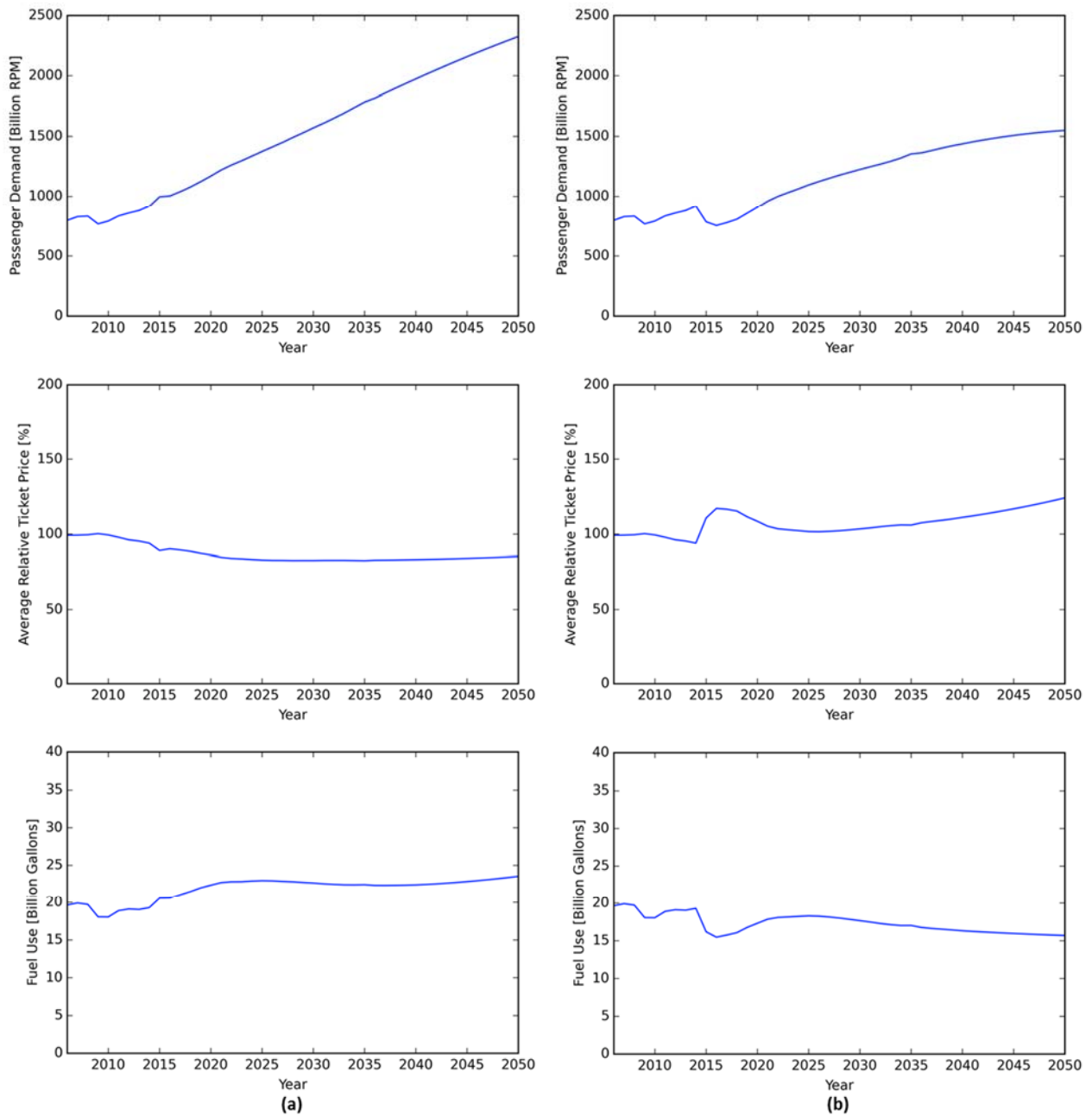


Figure 117 ITD Technology (a) Low fuel price; (b) High fuel price scenarios

## 6. Conclusions

The results obtained in this study show the potential benefits of various technology portfolios in the N+2 timeframe. Ranging from conservative to very optimistic, the results show what would be possible

to achieve as far as overall reductions in aviation environmental impacts considering the fuel use, NOx emissions, as well as noise.

The results show that the demand that is still forecast to grow significantly in the next decades will make it very hard to achieve no increases in environmental footprint or ever more ambitious to even achieve significant reductions. This means that aviation as a whole has to consider more and more aggressive technologies in similar time frames or even beyond the future considered here if aviation is to achieve a substantial reduction on environmental footprint by technology alone.

## 7. References

- [Airbus 2002] Airbus, "Getting to grips with aircraft performance," Airbus, 2002.
- [Airbus 2015] "Adverse Weather Operations, Windshear Awareness," Airbus.
- [Airbus 2015a] "Flight Operations Briefing Notes, " Approach Techniques, Flying Stabilized Approaches," Airbus
- [Anderson 1998] John. D. Anderson. Jr, Aircraft Performance and Design: McGraw-Hill Science/Engineering/Math, 1998.
- [ANP 2012] Aircraft Noise Performance (ANP) Database, Version 2.0, Eurocontrol Experimental Centre, December 2012, URL: [www.aircraftnoisemodel.org](http://www.aircraftnoisemodel.org).
- [Bach 1986] R E Bach jr, R C Wingrove, "The analysis of airline flight records for winds and performance with application to the delta 191 accident," NASA Ames Research Centre, 1986.
- [Bernardo 2015b] Bernardo, J. E., Kirby, M., Mavris, D., "Probabilistic Assessment of Fleet-Level Noise Impacts of Projected Technology Improvements"
- [Bernardo 2014] Bernardo, J. E., Lacouture, E. Kirby, M., Mavris, D., "Application of Mixture Design of Experiments for Dynamic Fleet-Level Evaluation of Multi-Objective Environmental Technology Trade-offs," *AIAA Aviation 2014, AIAA/3AF Aircraft Noise and Emissions Reduction Symposium*, AIAA 2014-2876, June 16<sup>th</sup> - 20<sup>th</sup>, Atlanta, GA, 2014, DOI: 10.2514/6.2014-2734
- [Bernardo, Jan. 2015] Bernardo, J. E., Besson, C., Pfaender, H., Schutte, J., Mavris, D., "A Multi-Stage Surrogate Modeling Approach to Examine Vehicle-Level Technology Impacts at the Airport-Level," *AIAA SciTech 2015, 53rd AIAA Aerospace Sciences Meeting*, AIAA 2015-0743, January 5-9, Kissimmee, FL, 10.2514/6.2015-0743
- [Bernardo, Jun. 2015] Bernardo, J. E., Kirby, M., Mavris, D., "Development of Generic Airport Categories for Rapid Fleet-Level Noise Modeling," *Journal of Aerospace Operations*, Vol. 3, No. 2, pp. 91-119, 2015. DOI: 10.3233/AOP-150045
- [Bernardo, May 2015] Bernardo, J. E., Kirby, M., Mavris, D., "Development of a Rapid Fleet-Level Noise Computation Model," *AIAA Journal of Aircraft*, Vol. 52, No. 3 (2015), pp. 721-733. DOI: 10.2514/1.C032503
- [Bock 2001] Bock, P., Schinwald, C., Airport Capacity Impact of New Aircraft Concepts: How to Manage Airport Diversity and Individuality, *CEAS Aeronautics Journal*, 2 (2001), 3-10.
- [Boeing 2011] "Statistical Summary of Commercial Jet Airplane Accidents, Worldwide operation 1959 - 2011," Aviation Safety, Boeing Commercial Airplanes, 2011.
- [Boeing 2015] Boeing. What is Angle of Attack [Online]. Available: [http://www.boeing.com/commercial/aeromagazine/aero\\_12/whatisaoa.pdf](http://www.boeing.com/commercial/aeromagazine/aero_12/whatisaoa.pdf)
- [Boeing 2015a] Boeing, "Aerodynamic Principles of Large-Airplane Upsets," ed. [http://www.boeing.com/commercial/aeromagazine/aero\\_03/textonly/fo01txt.html](http://www.boeing.com/commercial/aeromagazine/aero_03/textonly/fo01txt.html)
- [Bonet 2011] Bonet, J.T. et.al." Environmentally Responsible Aviation (ERA) Project – N+2 Advanced Vehicle Concepts Study and Conceptual Design of Subscale Test Vehicle (STV) Final Report". NASA CR-2011-XXXX. December 2011
- [Cornell 2002] Cornell, J. A., *Experiments with Mixtures: Designs, Models, and the Analysis of Mixture Data*, John Wiley and Sons, New York, 2002.
- [Cornell 2011] Cornell, J. A., *A Primer on Experiments with Mixtures*, John Wiley and Sons Inc., Hoboken, New Jersey, 2011.
- [Daggett 2003] David L Daggett, Ron Kawai, and Doung Friedman, "Blended Wing Body Systems Studies: Boundary Layer Ingestion Inlets With Active Flow Control," NASA/CR-2003-212670
- [ECAC 2005] ECAC.CEAC Doc 29, Report on Standard Method of Computing Noise Contours around Civil Airports – 3rd Edition, *European Civil Aviation Conference*, Neuilly-sur-Seine Cédex, France, Jul. 2005, URL: [http://www.aircraftnoisemodel.org/pdf/Doc29\\_3rd\\_Edition\\_Vol1\\_final.pdf](http://www.aircraftnoisemodel.org/pdf/Doc29_3rd_Edition_Vol1_final.pdf), Date Accessed: 10/23/2014.

- [Economon 2008] T.Economon, "Effects of Wake Vortices on Commercial Aircraft," AIAA Aerospace Sciences Meeting and Exhibit, 2008.
- [FAA 1989] "Airport Design, AC 150/5300 -13," ed: FAA, US Department of Transportation, 1989.
- [FAA 2012] Federal Aviation Administration, "AEM V. 7.0 - User's Manual," Office of Environment and Energy, Washington, DC, 2012.
- [FAA 2012b] Federal Aviation Administration, "AEM V. 7.0 - User's Manual," Office of Environment and Energy, Washington, DC, 2012.
- [FAA 2012c] FAA, "Air Traffic Organization Policy, Air Traffic Control," vol. JO 7110.65U CHG3, ed, 2012.
- [FAA 2013] Federal Aviation Administration, Terminal Area Forecast Summary Fiscal Years 2012 - 2040, 2013.
- [FAA 2014] Federal Aviation Administration, Terminal Area Forecast Summary Fiscal Years 2013 - 2040, 2014.
- [FAA INM 2014] Federal Aviation Administration, "Integrated Noise Model (INM) Version 7.0 User's Manual," [online government publication], FAA-AEE-08-01, URL: [https://www.faa.gov/about/office\\_org/headquarters\\_offices/apl/research/models/inm\\_model/inm7\\_0d/media/INM\\_7.0\\_User\\_Guide.pdf](https://www.faa.gov/about/office_org/headquarters_offices/apl/research/models/inm_model/inm7_0d/media/INM_7.0_User_Guide.pdf), [cited 18 November 2014].
- [FAA Jul. 2014] Federal Aviation Administration, Environmental Tool Suite Frequently Asked Questions, URL: [http://www.faa.gov/about/office\\_org/headquarters\\_offices/apl/research/models/toolsfaq/](http://www.faa.gov/about/office_org/headquarters_offices/apl/research/models/toolsfaq/), Jul. 2014.
- [FAA 2015] Federal Aviation Administration, Terminal Area Forecast Summary Fiscal Years 2014 - 2040, 2015.
- [FAA 2015a] "Stabilized Approach Concept," FAA Safety, [Online]. Available: <https://www.faasafety.gov/files/gslac/courses/content/35/376/Stabilized%20Approach%20Concept.pdf>
- [FAA Pilot Safety] FAA, "Pilot Guide to Take off Safety," FAA.
- [Flight Safety Foundation 2000] "Flight Safety Foundation ALAR Briefing Note, 8.7 Crosswind Landings," ed: Flight Safety Foundation, Flight Safety Digest, Aug-Nov 2000.
- [Frank 2013] Frank, C., Jimenez, H., Pfaender, H., Mavris, D., "Scenario Development to Evaluate System-wide Environmental Benefits of Aircraft Technologies and Concepts," AIAA AVIATION 2013, AIAA 2013-4317, 2013 Aviation Technology, Integration, and Operations Conference, August 12-14, 2013, Los Angeles, CA
- [Frost 1984] Walter Frost, Ronald L Bowles, "Wind Shear Terms in the Equations of Aircraft Motion," *Journal of Aircraft*, Vol21, No 11, 1984.
- [Gallman 1992] S. C. S. a. I. M. K. John W Gallman, "Optimization of Joined-Wing Aircraft," *Journal of Aircraft*, vol. 30, Nov-Dec 1993 1992.
- [Ghigliazzam 2007] Horacio H. Ghigliazzam, Rodrigo Martinez -Val, Emilio Perez, Ladislav Smrcek, "Wake of Transport Flying Wings," *Journal of Aircraft*, vol. 44, 2007.
- [Hileman 2007] James I Hileman, Tom G Reynolds, Elena de la Rosa Blanco, Thomas R. law, Steven Thomas, "Development of Approach Procedures for Silent Aircraft," AIAA Aerospace Sciences Meeting and Exhibit, 2007.
- [Hollingsworth 2011] Hollingsworth, P., Sulitzer, D., "Investigating the Potential of Using Quota Count as a Design Metric," *AIAA Journal of Aircraft*, Vol. 38, No. 6, 2011, pp. 1894-1902. doi: 10.2514/1.C031294.
- [Jimenez 2012] Jimenez, H., Pfaender, H., Mavris, D., "Fuel Burn and CO2 System-Wide Assessment of Environmentally Responsible Aviation Technologies," *AIAA Journal of Aircraft*, Vol. 49, No. 6, November-December 2012, DOI: 10.2514/1.C031755.
- [Kirby 2008] Kirby, M., and Mavris, D., 2008. "The Environmental Design Space," 26th International Congress of the Aeronautical Sciences. ICAS-2008-4.7.3.
- [Kish 2008] Kish, C., "An Estimate of the Global Impact of Commercial Aviation Noise", Master's Thesis, Massachusetts Institute of Technology, Jun., 2008.

- [Kroo 1989] J. G. Ilan Kroo, and Stephen Smith, "Aerodynamics and Structural Studies of Joined-Wing Aircraft," *Journal of Aircraft*, vol. 28, 1989.
- [Lange 1974] Lange, R. H., Cahill, J. F., Bradley, E. S., Eudaily, R. R., Jenness, C. M. and MacWilkinson, D. G., "Feasibility Study of the Transonic Biplane Concept for Transport Aircraft Application", NASA CR-132462, 1974.
- [LeVine 2014] LeVine, M. J., Wilson, A., Kirby, M., Mavris, D., "Development of Generic Vehicles for Fleet-Level Analysis of Noise and Emissions Tradeoffs," *AIAA Aviation 2014, AIAA/3AF Aircraft Noise and Emissions Reduction Symposium*, AIAA 2014-2731, June 16<sup>th</sup> - 20<sup>th</sup>, Atlanta, GA, 2014, DOI: 10.2514/6.2014-2731.
- [Liu 2007] C. Liu, "Wake Vortex Encounter Analysis with Different Wake Vortex Models Using Vortex Lattice Method," Master of Science in Aerospace engineering, TU Delft Aerodynamics, Delft University of Technology, 2007.
- [Long 1999] Long, Dou, Lee, David, Johnson, Jesse, Gaier, Eric, and Kostiuk, Peter, "Modeling Air Traffic Management Technologies with a Queuing Network Model of the National Airspace System," NASA CR 2001-208988, Jan. 1999.
- [Lowry 1999] John. T. Lowry, *Performance of Light Aircraft*: AIAA, 1999.
- [Park 2016] S Park, Clarke JP, Feron E., Jimenez H., "Separation Assurance and Scheduling Coordination in the Arrival environment," AIAA-2016-1631, Presented at the 54th Aerospace Sciences Meeting, 4-8 Jan, 2016, San Diego CA
- [Pfaender 2009] Holger Pfaender, Peter Hollingsworth, Henry Won, "Environmental Challenge: How to close the gap between policy and technology?" ATIO 2009, Hilton Head, SC; 2009.
- [Pfaender 2010] Pfaender, H., Jimenez, H., Mavris, D., "A System Dynamics Analysis of Fleet Technology and Policy Options for Environmental Impact Mitigation" *27th International Congress of the Aeronautical Sciences*. 2010;Nice, France.
- [Pfaender 2010b] Pfaender, H., Jimenez, H., Mavris, D., "Environmental Impact Analysis of Fleet and Policy Options of Aircraft Operators using System Dynamics", *10th AIAA Aviation Technology, Integration, and Operations Conference (ATIO)*. 2010;Fort Worth, TX.
- [Pfaender 2011] Pfaender, H., Mavris, D., "Technology Effects on Aircraft Fleet Decisions", *11th AIAA Aviation Technology, Integration, and Operations (ATIO) Conference, including the AIAA Balloon Systems Conference and 19th AIAA Lighter-Than Air Conference*, 2011.
- [Plas 2007] A P Plas, M A Sargeant C Madani, D Crinton, E M Greitzer, T P Hynes, C A Hall, "Performance of Boundary Layer Ingesting (BLI) Propulsion System," AIAA Aerospace Sciences Meeting and Exhibit, 2007.
- [Prandtl 1924] Prandtl, L., "Induced Drag of Multiplanes", NACA TN 182, 1924.
- [SAE 2012] Society of Automotive Engineers "Procedure for the Calculation of Airplane Noise in the Vicinity of Airports," [online standard publication], SAE AIR 1845, SAE Committee A-21, Aircraft Noise, URL: <http://standards.sae.org/air1845a/>, Date Accessed: 10/23/2014.
- [Salam 2012] Salam, I. R. and Bil, C., "Preliminary Aerodynamic and Structural Design Tradeoff for a Box-Wing Airliner", AIAA 2012-0251, 2012.
- [Schutte 2012] Schutte, J., Tai, J., Mavris, D., "Multi-Design Point Cycle Design Incorporation into the Environmental Design Space," 48th AIAA/ASME/SAE/ASEE Joint Propulsion Conference & Exhibit, July 2012, AIAA 2012-3812.
- [Skybrary 2015] "Wake Vortex Propagation and Decay," ed: [http://www.skybrary.aero/index.php/Wake\\_Vortex\\_Propagation\\_and\\_Decay](http://www.skybrary.aero/index.php/Wake_Vortex_Propagation_and_Decay)
- [Stouffer 2013] Virginia L Stouffer, Robert V. Hemm, "A Top Level Safety Analysis of N+2 Aircraft in NextGen Operations," presented at the Aviation Technology, Integration, and Operations Conference, Los Angeles CA, 2013.
- [Tetzloff 2009] Tetzloff, I. J., Crossley, W. A., "An Allocation Approach to Investigate New Aircraft Concepts and Technologies on Fleet-Level Metrics," 9th AIAA Aviation Technology, Integration, and Operations Conference (ATIO), AIAA 2009-6979, Hilton Head, South Carolina, 2009.

[Valdes 2011] Rosa Maria Arnaldo Valdes, Fernando Gomez Comendador, Luis Mijares Gordun, Francisco J Saez Nieto, "The development of probabilistic models to estimate accident risk (due to runway overrun and landing undershoot) applicable to the design and construction of runway safety areas," *Safety Science*, 2011.

[Wolkovitch 1985] J. Wolkovitch, "The Joined Wing: An Overview," presented at the AIAA 23rd Aerospace Science Meeting, Reno, NV, 1985.

[Xie 2003] Yue Xie, John Shortle, George Donohue, "Runway Landing Safety Analysis: A Case Study of Atlanta Hartsfield Airport," *IEEE*, 2003.

**REPORT DOCUMENTATION PAGE**

*Form Approved  
OMB No. 0704-0188*

The public reporting burden for this collection of information is estimated to average 1 hour per response, including the time for reviewing instructions, searching existing data sources, gathering and maintaining the data needed, and completing and reviewing the collection of information. Send comments regarding this burden estimate or any other aspect of this collection of information, including suggestions for reducing this burden, to Department of Defense, Washington Headquarters Services, Directorate for Information Operations and Reports (0704-0188), 1215 Jefferson Davis Highway, Suite 1204, Arlington, VA 22202-4302. Respondents should be aware that notwithstanding any other provision of law, no person shall be subject to any penalty for failing to comply with a collection of information if it does not display a currently valid OMB control number.  
**PLEASE DO NOT RETURN YOUR FORM TO THE ABOVE ADDRESS.**

<b>1. REPORT DATE (DD-MM-YYYY)</b> 01-05 - 2016		<b>2. REPORT TYPE</b> Contractor Report		<b>3. DATES COVERED (From - To)</b>	
<b>4. TITLE AND SUBTITLE</b>  Application of Strategic Planning Process with Fleet Level Analysis Methods				<b>5a. CONTRACT NUMBER</b> NNL12AA14C	
				<b>5b. GRANT NUMBER</b>	
				<b>5c. PROGRAM ELEMENT NUMBER</b>	
<b>6. AUTHOR(S)</b>  Mavris, Dimitri N.; Pfaender, Holger; Jimenez, Hernando; Garcia, Elena; Feron, Eric; Bernardo, Jose				<b>5d. PROJECT NUMBER</b>	
				<b>5e. TASK NUMBER</b>	
				<b>5f. WORK UNIT NUMBER</b> 338881.02.07.07.08.66	
<b>7. PERFORMING ORGANIZATION NAME(S) AND ADDRESS(ES)</b> NASA Langley Research Center Hampton, Virginia 23681				<b>8. PERFORMING ORGANIZATION REPORT NUMBER</b>	
<b>9. SPONSORING/MONITORING AGENCY NAME(S) AND ADDRESS(ES)</b> National Aeronautics and Space Administration Washington, DC 20546-0001				<b>10. SPONSOR/MONITOR'S ACRONYM(S)</b>  NASA	
				<b>11. SPONSOR/MONITOR'S REPORT NUMBER(S)</b> NASA/CR-2016-219200	
<b>12. DISTRIBUTION/AVAILABILITY STATEMENT</b> Unclassified - (Unlimited) Subject Category 01 Availability: NASA STI Program (757) 864-9658					
<b>13. SUPPLEMENTARY NOTES</b> Final Report  Langley Technical Monitor: Frank H. Gern					
<b>14. ABSTRACT</b>  The goal of this work is to quantify and characterize the potential system-wide reduction of fuel consumption and corresponding CO2 emissions, resulting from the introduction of N+2 aircraft technologies and concepts into the fleet. Although NASA goals for this timeframe are referenced against a large twin aisle aircraft we consider their application across all vehicle classes of the commercial aircraft fleet, from regional jets to very large aircraft. In this work the authors describe and discuss the formulation and implementation of the fleet assessment by addressing the main analytical components: forecasting, operations allocation, fleet retirement, fleet replacement, and environmental performance modeling.					
<b>15. SUBJECT TERMS</b>  Aircraft; Commercial; Environmental; Fleet; Fuel consumption; Strategic planning					
<b>16. SECURITY CLASSIFICATION OF:</b>			<b>17. LIMITATION OF ABSTRACT</b>	<b>18. NUMBER OF PAGES</b>	<b>19a. NAME OF RESPONSIBLE PERSON</b>
<b>a. REPORT</b>	<b>b. ABSTRACT</b>	<b>c. THIS PAGE</b>			STI Help Desk (email: help@sti.nasa.gov)
U	U	U	UU	208	<b>19b. TELEPHONE NUMBER (Include area code)</b> (757) 864-9658