

SSC16-II-04

Solidifying Small Satellite Access to Orbit via the International Space Station (ISS): Cyclops' Deployment of the Lonestar SmallSat from the ISS

Matthew P. Hershey, Daniel R. Newswander, Brent A. Evernden,
NASA Johnson Space Center
2101 NASA Parkway, Houston, TX 77058; 281-483-2304
matthew.p.hershey@nasa.gov

ABSTRACT

On January 29, 2016, the Space Station Integrated Kinetic Launcher for Orbital Payload Systems (SSIKLOPS), known as "Cyclops" to the International Space Station (ISS) community, deployed Lonestar from the ISS. The deployment of Lonestar, a collaboration between Texas A&M University and the University of Texas at Austin, continued to showcase the simplicity and reliability of the Cyclops deployment system. Cyclops, a NASA-developed, dedicated 10-100 kg class ISS SmallSat deployment system, utilizes the Japanese airlock and robotic systems to seamlessly insert SmallSats into orbit. This paper will illustrate Cyclops' successful deployment of Lonestar from the ISS as well as outline its concept of operations, interfaces, requirements, and processes.

INTRODUCTION

Cyclops, the first dedicated 10-100 kg class small satellite deployment system for the ISS, which became operational following its successful deployment of the SpinSat satellite in November of 2014^{1,2}, depicted by the photograph in Figure 1, repeated its achievement with the deployment of the Lonestar satellite in January of 2016.



**Figure 1: "SpinSat deployment from Cyclops"
(Photo credit: NASA)**

Cyclops provides the ISS Program with a method for transferring large, internally-stowed satellites, referred to as "payloads" through the remainder of the document, of a wide variety of shapes to the external ISS environment and deploying them safely away from the ISS. It is a reusable, on-orbit ISS facility that can be utilized by payload developers easily and cost effectively. Once the ISS Program manifests the customer's payload for flight, the ISS program will

provide a standardized interface upon request, known as the Experiment Attach Fixture (EAF), as well as opportunities for launch and ISS deployment. The payload developer will likely be responsible for any costs associated with the ISS Payload and Safety Processes.

Cyclops was developed as a NASA ISS Program and Department of Defense Space Test Program sponsored device³, designed to go beyond the ISS's existing CubeSat-sized payload deployment capability³. On the ISS, Cyclops expands the limits for deployed payload mass up to 100 kg and volume up to 0.4644 m³ (the largest to-date size of a JEM-Airlock-constrained payload), allowing a new class of larger deployable payloads to utilize the ISS as a research platform.

The successful deployment of the Lonestar satellite, Cyclops' concept of operations, its user interfaces, and a summary of the critical Cyclops' requirements for payload users will be addressed. The available avenues to utilize this unique resource as well as acknowledgements will also be covered.

LONESTAR DEPLOYMENT

Cyclops, which was launched to the ISS on SpaceX CRS-4 in September 2014 and successfully deployed SpinSat later that year, welcomed Lonestar to the ISS in December 2015 on OA-4. Both the satellite and the deployment system were stored inside the ISS until late January 2016, when the ISS crew attached Cyclops and Lonestar to the Japanese Airlock (JEM) Slide Table in preparation for external environment robotic transfer and deployment operations.

On January 29th, 2016, at 14:30 UTC (08:30 CST), Cyclops successfully deployed the Lonestar satellite from the ISS into orbit. Figure 2 is a photograph taken by the crew inside of the JEM showing Lonestar attached to Cyclops temporarily positioned above the JEM Exposed Facility. This occurred after Cyclops had been mounted to the JEM Airlock Slide Table, processed through the Airlock and extended into the external environment.

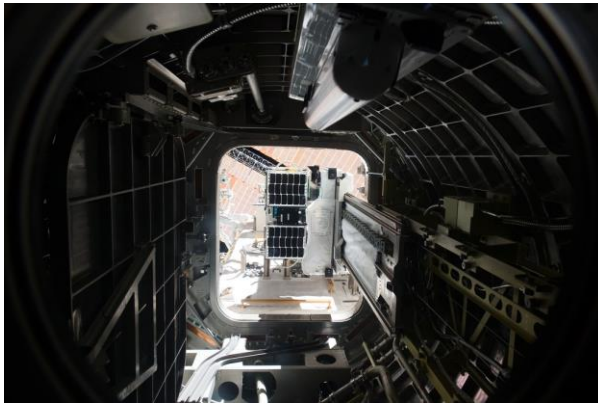

Figure 2: “Cyclops / Lonestar through JEM Airlock” (Photo credit: NASA)

Figures 3 and 4 depict Lonestar moments before its deployment by Cyclops at the end of the JEM Small Fine Arm. Preliminary assessments estimated that the Lonestar departed at a velocity of about 0.1 m/s, and it was confirmed that the satellite reached its planned safe distance from the ISS. Texas A&M University (TAMU) and the University of Texas at Austin (UT) students successfully established communication with Lonestar. Since deployment, Lonestar has continued to accomplish its mission objectives and provide data to TAMU and UT.

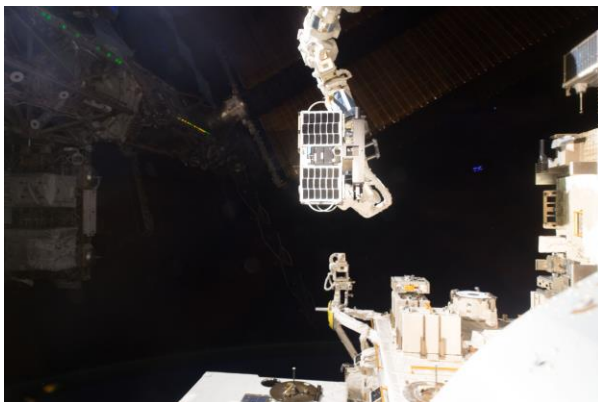

Figure 3: “Lonestar deployment from Cyclops” (Photo credit: NASA)



Figure 4: “Lonestar deployment from Cyclops” (Photo credit: NASA)

CONCEPT OF OPERATIONS

Cyclops hardware components, its sequence for deployment of payloads, and an example of payload deployment will be addressed.

Cyclops Hardware Components

Cyclops is a structural/mechanical system that consists of the following two major components: the Cyclops Unit and the Cyclops Unique Tools. The Cyclops Unit is the system used for airlock translation and deployment. The Cyclops Unique Tools, which are tools used by the crew for Cyclops setup, remain internal to ISS and ensure the Cyclops Unit is properly configured once the deployable payload is installed. The operational nomenclature or Op-Nom “Cyclops” is typically used to refer to only the Cyclops Unit, i.e. the deployment system that transitions through the airlock and that gets moved and actuated by the robotic arm.

The Cyclops Unit itself is comprised of the Mechanical Deployment Subsystem, the Retention & Release

Mechanism and the Robotic Grasp Fixture Interface Plate.

The Mechanical Deployment Subsystem includes the Primary Deployment (pusher-plate) Mechanism, the IVA Preload Interface (for the primary system) as well as a back-up Secondary Spring Deployment Mechanism that will deploy the payload in the event of a pusher-plate mechanism failure.

The Retention & Release Mechanism (RRM) is used to securely retain the payload during translation operations and to release the payload when the Cyclops Unit is actuated for deployment.

The Robotic Grasp Fixture Interface Plate enables robotic translation by the JEM Small Fine Arm (SFA) or by the Special Purpose Dexterous Manipulator (SPDM) as well as the initialization of Cyclops's deployment function.

Each payload planned for deployment is delivered to the ISS separately from Cyclops and is attached to Cyclops by the ISS crew prior to its translation to the external environment and subsequent deployment.

An overview of the Cyclops payload illustrating its major components is shown in Figure 5 below, Cyclops Hardware Overview.

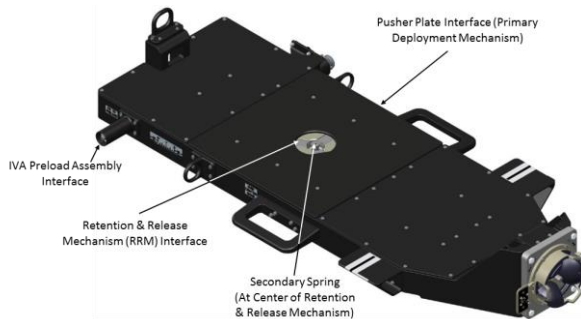

Figure 5: Cyclops Hardware Overview

Cyclops Deployment Sequence

The Operations for a typical Cyclops mission are shown in Figure 6.

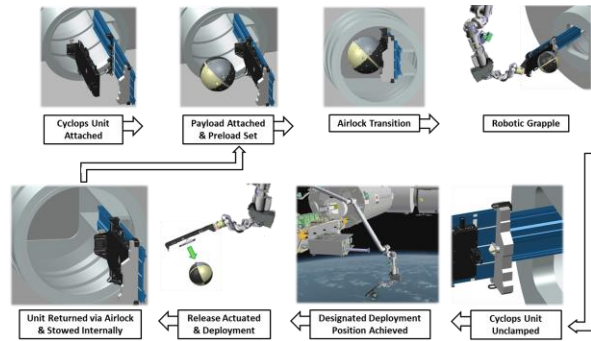

Figure 6: Cyclops Concept of Operations

Cyclops provides a standardized method and interface for deploying payloads from the ISS using either the SPDM or the JEM SFA. Payloads utilizing the Cyclops payload facility are deployed from ISS using the Cyclops Unit and the one of two robotic manipulators.

Once on-orbit, the Cyclops system is stowed in the pressurized environment inside of its own stowage bag. In preparation for Cyclops operations, the Cyclops Unit is installed onto the JEM Airlock Slide Table and retained in place by the Slide Table capture mechanism. After that, the deployable payload is positioned onto the Cyclops Unit's pusher plate and grasped by the Cyclops Unit's RRM. Finally, the preload interface on the Cyclops Unit is used to add stored energy to the system, just prior to Cyclops and its payload being inserted into the JEM Airlock and depressurized for external operations.

Cyclops and its payload are then transferred to their deployment location, where the payload is deployed. Cyclops is then returned through the airlock and stowed for future payload utilization.

Cyclops Payload Deployment Example

Figure 7 shows an example of the deployment of a payload, generically illustrating how Cyclops will apply a force to the payload. Cyclops provides the required deployment velocity (delta velocity or "Delta V") for safe separation from ISS.

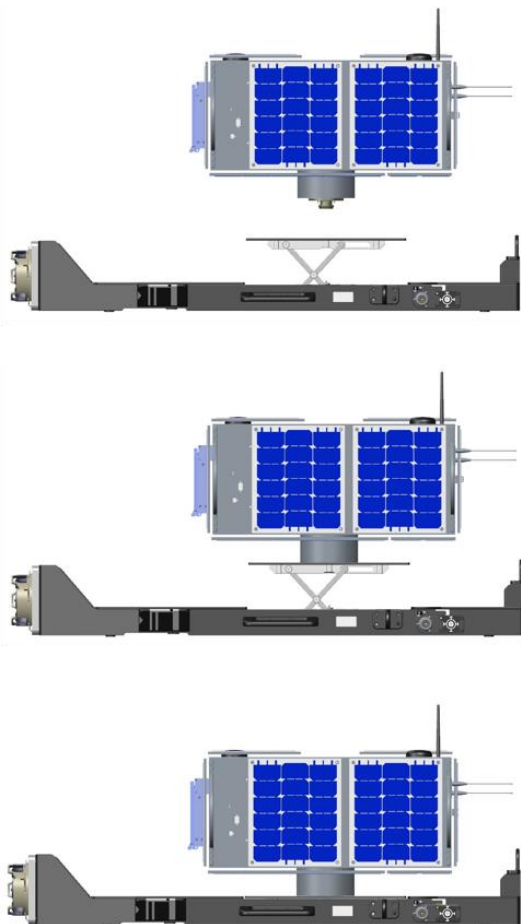

Figure 7: Satellite Deployment Example

USER INTERFACES

Standardized Fixture for Satellites

The (EAF), shown in Figure 8 and provided by the ISS Program, becomes part of the deployable payload itself during the payload’s fabrication, assembly and certification process on the ground. The EAF is the interface that aligns and secures the deployable payload to Cyclops through use of the RRM. Request for procurement of the EAF, including the need date for its installation and integration with the payload, is coordinated between the payload developer and the ISS Program.

Cyclops Interfaces

The Cyclops retention mechanism is closed by the crew via the Robotic Grasp Fixture Interface Plate’s drive bolt. The RRM clamps around the EAF and locks the deployable payload in place for all ensuing operations, including Cyclops & payload transfer from inside to outside the ISS on the slide table, and for robotic manipulation to the deployment location.

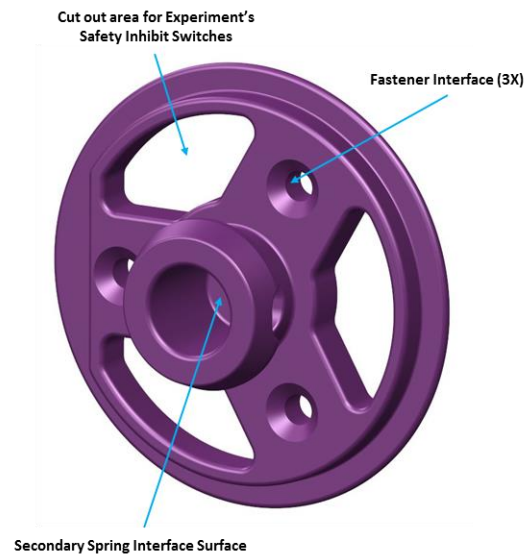

Figure 8: Experiment Attachment Fixture

SUMMARY OF CRITICAL CYCLOPS REQUIREMENTS

Applicability of Cyclops User Requirements

The following sections provide a summary of requirements levied by the Space Station Program on Cyclops Users that may impact early-stage hardware design and project planning activities.

However, it is important to note that due to on-going review and the potential for modification of these requirements, Cyclops Users should work through their ISS POC to obtain the most up-to-date, formalized versions of these and other requirements relevant to ISS payloads.

The deployable payload developer must verify the appropriate subsection of SSP 57003, in Section 3.14 “Deployable Payload Requirements”, will be met to ensure safe deployment from ISS.

Cyclops User Mass, C.G. and Inertia Property Requirements

The Cyclops User requiring Cyclops deployment shall have mass, center of gravity and inertia properties in accordance with Table 1 and Table 2 below, Cyclops User Mass Properties for CG and Inertia. Note that the experiment/satellite assembly includes the EAF. The EAF mass is 0.89 lbm (0.40 kg), not including fasteners. Verification of the Cyclops user mass and CG properties shall be by test.

Table 1: Cyclops User Mass Properties: CG

Mass	CG †		
	X, (in)	Y, (in)	Z, (in)
22.0 to 220.5 lbm (10 to 100 kg)	-1.00 to 1.00	2.00 to 14.20	-1.00 to 1.00

†, Table 1: The X, Y and Z values are defined with respect to the Cyclops user local coordinate system [X, Y, Z]_{EAF} defined in drawing SLG29103601, per View-608 on Sheet 4 and Flag Note 5 on Sheet 1.

Table 2: Cyclops User Mass Properties: Inertia

Mass	Moments of Inertia		
	Ixx, (lbm-in ²)	Iyy, (lbm-in ²)	Izz, (lbm-in ²)
22.0 to 220.5 lbm (10 to 100 kg)	0 to 76900	0 to 64400	0 to 61450

Cyclops User Mounting Interface Requirements

The deployable payload shall use the provided EAF as the only mechanical attachment between the Cyclops and the deployable payload.

The EAF shall be ground installed on the Cyclops deployable payload per the “Jettison System – Interface Control Drawing” SLG29103601, View-608 “Experiment Attachment” on sheet 4, such that it meets the following criteria:

The payload shall meet cleanliness requirements stated in Flag Note 1 of SLG29103601, called out by View-608. The payload base structure to which the EAF is attached shall be made of 7075-T7351 Aluminum Alloy per the notes and specifications in View-608.

The Ø3.50-inch faying surface of the payload, where the EAF will be mounted, shall be chemical conversion coated (Class 1A per NASA/JSC PRC-5005) per View-608.

Inserts for three fasteners shall meet the location specifications, positional tolerances, sealing requirements and part specifications (MS21209F4-15L) per the notes in View-608 and Section B-B of View-608.

The EAF shall be attached to the payload via three fasteners that meet the part specifications (NAS1102E4-14), installation depth and installation torque noted in Section B-B of View-608.

Cyclops User Coordinate System Requirements

The Cyclops User coordinate system shall be defined per the “Jettison System – Interface Control Drawing”

SLG29103601, per View-608 “Experiment Attachment” on Sheet 4, at the coordinate system origin of the NASA-provided Experiment Attachment Fixture (EAF) for Cyclops payloads. See Figure 9 below for reference views of the EAF CSYS axis directions and origin offset. Verification of the Cyclops User coordinate system shall be by inspection.

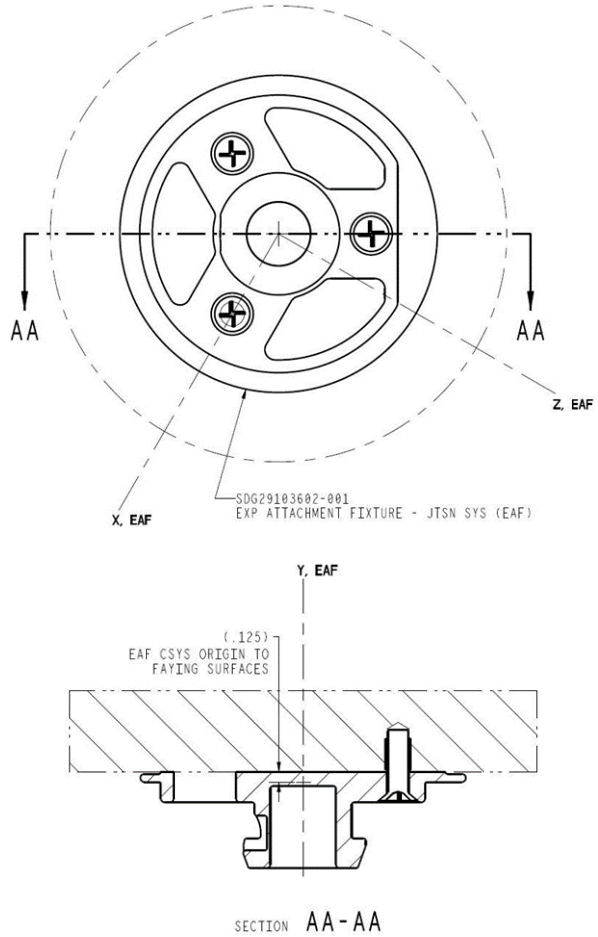

Figure 9: Location and Orientation of EAF Coordinate System Axes

Cyclops User Maximum Envelope Requirements

The deployable payload shall be contained within the envelope for Cyclops deployable payloads as defined in SLG29103601, View-609 “Experiment Envelope” on Sheet 5. This Experiment Envelope is defined relative to the same EAF coordinate system referenced in View-608 on Sheet 4. Figure 9, below, shows a side view of the experiment envelope for reference. Verification of the Cyclops User Maximum Envelope Requirements shall be by Test, through measurements of payload flight hardware dimensions after final assembly, as well as by Analysis which accounts for worst case thermal distortion of the payload dimensions.

The EAF is not considered part of the volumetric envelope, as shown in Figure 10.



Figure 10: Cyclops Experiment Envelope

Cyclops User Switch Installation Requirements

The deployable payload shall design and test their inhibit switch in accordance with SLG29103601, View-610 “Inhibit Switch Configuration” on Sheet 6 and in compliance with Flag Note 3 on Sheet 1.

Verification of the inhibit switch installation and location requirements shall be by Inspection and Test, through the measurement of dimensions of the payload flight hardware after final assembly. Measurements shall be taken and reported relative to the EAF CSYS.

Cyclops User Acceleration Environment Requirements

The deployable payload requiring Cyclops deployment shall be designed to withstand Airlock slide table nominal acceleration load of 0.04 g in any direction.

The deployable payload requiring Cyclops deployment shall be designed to withstand Airlock slide table contingency acceleration loads in accordance with Table 3.

Table 3: Contingency Acceleration along Axis of Slide Table Motion

Deployable Payload Mass *	Acceleration
22.0 to 220.5 lbm (10 to 100 kg)	0.20 g

*, Table 3: Mass does not include Cyclops.

Cyclops User Maximum Deployment Force Requirements

The deployable payload requiring Cyclops deployment shall be designed to withstand acceleration from a maximum deployment force of 35 lb.

This includes the force from the pusher plate, secondary spring, and inhibit switches.

Cyclops User Airlock Pressure Requirements

The deployable payload requiring Cyclops deployment shall maintain positive margins of safety for the range of Airlock pressure and depress/repress rates in accordance with NASDA-ESPC-2903 JEM Payload Accommodation Handbook, paragraph 4.5.2.1 “Airlock Pressure”.

This requirement is applicable to any hardware being transferred within the JEM Airlock. This assessment is performed by the Cyclops User.

From NASDA-ESPC-2903 JEM Payload Accommodation Handbook, Revision B: The pressure inside the AL is the pressure when the air is vacuumed or re-pressurized with the inner/outer hatches closed. The payload shall survive the following pressure range and depressurization/re-pressurization rate: AL pressure of 0 to 104.8kPa, and AL pressure depressurization/re-pressurization rate of 1.0kPa/sec (max).

Cyclops User Thermal Requirements

All relevant thermal constraints on the JEM airlock, the Cyclops components, and the deployable payload are expected to be addressed and confirmed by task-specific assessments based on as-planned transfer operations and timelines, with any constraint violations being controlled through operational means rather than deployable payload design changes. Verification of Cyclops User Thermal Requirements shall be by analysis.

Table 4 shows approximate times for various activities associated with Cyclops deployment, including contingency activities.

Note that thermal requirements are assessed as part of an integrated thermal analysis performed by the Payload Developer, using appropriate thermal models.

Also, the Cyclops thermal model is sustained and provided by NASA. NASA will re-issue the Cyclops model as either Cyclops or JEM Airlock model updates warrant.

Furthermore, the JEM Airlock model is sustained by Japan Aerospace Exploration Agency (JAXA). JAXA will re-issue JEM Airlock model when updates warrant (e.g., to incorporate ISS models that reflect ISS configuration updates). ISS payload models are sustained by the ISS integrator or by the appropriate International Partner provider.

Table 4: Cyclops User Thermal Timeline

Activity	Approximate Time (hours)
Airlock Depressurization	3.0
Airlock Hatch Exit to Deployment	5.0
SPDM Contingency Securing Operations	Addressed during real-time operations in the event of a contingency.
Cyclops Return Transfer to Airlock Hatch (Contingency for Deployable Payload)	5.0
Airlock Re-pressurization (Contingency for Deployable Payload)	20.0

Cyclops User Airlock Thermal Environment Requirements

The deployable payload requiring Cyclops deployment shall be capable of surviving 1.5 hours in the JEM airlock thermal environment, using the thermal interface conditions defined in NASDA-ESPC-2903, Tables 5 and 6, and by Figure 11. Verification of Cyclops User Airlock Thermal Environment Requirements shall be by analysis.

Table 5: Thermal Interface between Capturing Type Payload and the Slide Table

Operation/Airlock Condition		Payload export †	Payload export/import ††	Payload import **
Interface				
Interface Temperature of the Airlock slide table surface		+14 to +33 °C	+10 to +60 °C	+12 to 45 °C
Point of interface	Allowable Heat Flux (W/m ²)	N/A	< 135°C (slide table cold case) * > -375°C (slide table hot case) *	N/A
Payload interface temperature		+14 to +33 °C	N/A	+12 to 45 °C

Definitions for Operation/Airlock conditions in Table 5 are as follows: The Payload export condition is when the slide table is stored in the Airlock (Outer hatch: closed, Airlock Pressure: 1 atm). The Payload export/import condition is when the slide table is extended in the exposed area. The Payload import condition occurs after the slide table is stored and before the Airlock is re-pressurized (Outer hatch: closed, Airlock pressure: 0 atm).

*, Table 5: Radiation/conduction heat exchange between the payload bottom surface and the slide table shall be within this limit when the interface temperature of the Airlock slide table surface is fixed as the

boundary condition for thermal analysis. It is not applicable when the interface temperature of the Airlock slide table surface is not fixed as the boundary condition for thermal analysis. The interface condition of radiation shall comply with the JMX-2010458: JEM Integrated Thermal Mathematical Models. For the cold case of the slide table, heat flow shall be within the shown limit when the slide table boundary temperature is 10°C (the lowest temperature of the slide table when extended). For the hot case of the slide table, heat flow shall be within the shown limit when the slide table boundary temperature is 60°C (the highest temperature of the slide table when extended).

** , Table 5: This temperature condition is required for re-pressurizing the Airlock. (Re-pressurization will be started after this condition is satisfied. Standby time which meets this condition shall be calculated via thermal analysis.)

† , Table 5: Initial conditions of the thermal analysis for the Airlock vacuum exhaust phase can be obtained from the JMX-2010458, JEM Integrated Thermal Mathematical Models. Or alternately, temperature conditions shown in this table can be applied to the analysis.

†† , Table 5: This item shall be verified. Conditions other than the one described by this item are used for initial conditions or boundary conditions of the thermal analysis.

Table 6: Thermal Interface between Bolt-Fixed Type Payload and the Slide Table

Operation/Airlock Condition		Payload export †	Payload export/import ††	Payload import **
Interface				
Interface Temperature of the Airlock slide table surface		+14 to +33 °C	+10 to +60 °C	+12 to 45 °C
Point of interface	Allowable Heat Flux (W/m ²)	N/A	< 135°C (slide table cold case) * > -375°C (slide table hot case) *	N/A
Payload interface temperature		+14 to +33 °C	N/A	+12 to 45 °C

Definitions for Operation/Airlock conditions in Table 6 are as follows: The Payload export condition is when the slide table is stored in the Airlock (Outer hatch: closed, Airlock Pressure: 1 atm). The Payload export/import condition is when the slide table is extended in the exposed area. The Payload import condition occurs after the slide table is stored and

before the Airlock is re-pressurized (Outer hatch: closed, Airlock pressure: 0 atm).

*, Table 6: Radiation/conduction heat exchange between the payload bottom surface and the slide table shall be within this limit when the interface temperature of the Airlock slide table surface is fixed as the boundary condition for thermal analysis. It is not applicable when the interface temperature of the Airlock slide table surface is not fixed as the boundary condition for thermal analysis. The interface condition of radiation shall comply with the JMX-2010458: JEM Integrated Thermal Mathematical Models. For the cold case of the slide table, heat flow shall be within the shown limit when the slide table boundary temperature is 10°C (the lowest temperature of the slide table when extended). For the hot case of the slide table, heat flow shall be within the shown limit when the slide table boundary temperature is 60°C (the highest temperature of the slide table when extended).

** , Table 6: This temperature condition is required for re-pressurizing the Airlock. (Re-pressurization will be started after this condition is satisfied. Standby time which meets this condition shall be calculated via thermal analysis.)

† , Table 6: Initial conditions of the thermal analysis for the Airlock vacuum exhaust phase can be obtained from the JMX-2010458, JEM Integrated Thermal Mathematical Models. Or alternately, temperature conditions shown in this table can be applied to the analysis.

†† , Table 6: This item shall be verified. Conditions other than the one described by this item are used for initial conditions or boundary conditions of the thermal analysis.

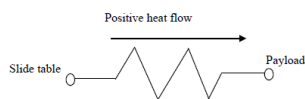

Figure 11: Thermal Model Diagram

Cyclops User Contact Temperature Limits

The deployable payload requiring Cyclops deployment shall ensure that it does not cause the Cyclops/JEM components to exceed their limits as defined in Table 7. Verification of Cyclops User Contact Temperature Requirements shall be by analysis.

Table 7: Cyclops User Contact Temperature Limits

Component *	Lower Limit	Upper Limit
Cyclops Component	-61 °C	+65 °C
JEM: Slide Table	+10 °C	+60 °C
JEM: Active Mechanism	-15 °C	+95 °C

*, Table 7: Timeline-specific, integrated thermal analysis will be used to define constraints to protect all thermal limits and are performed by the Payload Developer (PD).

Cyclops User Survivability

The deployable payload shall remain safe after exposure to the external environment (from the time of exiting the JEM Airlock hatch until deployment) for no less than 10 hours unpowered. Verification of Cyclops User Survivability Requirements shall be by test and analysis.

Cyclops User Bonding Requirements

The deployable payload shall provide a Class S electrical bonding path to the EAF, through the areas where the Teflon coating has been removed as shown in Figure 12, in accordance with SSP 30245. The Electrical Bonding of the deployable payload EPCE shall be verified by Test, Analysis and Inspection.

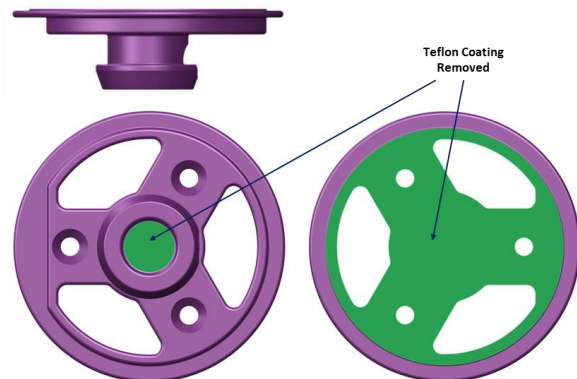

Figure 12: EAF User Bonding Surfaces

Cyclops User Ballistic Number Requirements:

The Attached Payload planned for deployment shall meet the Ballistic Number requirements per Table 8.

Table 8: Ballistic Number Based on Deployment Velocity

Retrograde Deployment Velocity Component, dV †††	Maximum Ballistic Number (based on payload minimum frontal area) *, **, ***, †, ††
$dV \leq 0.5$ m/s	≤ 100 kg/m ²
$dV > 0.5$ m/s	≤ 120 kg/m ²

*, Table 8: Ballistic Number (BN) for payload is computed assuming a coefficient of drag (Cd) of 2.0.

**, Table 8: BN for payloads is computed using payload dimensions with appendages (antennas and solar arrays) in the stowed configuration to account for the failure of appendages to deploy.

***, Table 8: Deployed Payload attitude control systems are accounted for in the BN computation if they are passive and are not dependent on appendage deploys.

†, Table 8: Deorbit devices are not to be considered for BN computation.

††, Table 8: Refer to SSP 57003 (NASA JSC document) section 3.14 for details on BN computation.

†††, Table 8: The retrograde component of deployment velocity is defined as the velocity component in the ISS –X direction, assuming the ISS is in the +XVV Torque Equilibrium Attitude (TEA).

It’s important to note that the deployment velocity from Cyclops is less than 0.5 m/s.

Payload Developers can calculate the payload’s Ballistic Number using the following equation:

$$BN = \frac{M}{C_d A_f} \quad (1)$$

In Equation (1), BN is the Ballistic Number, M is Mass (kg), C_d is the Coefficient of Drag and A_f is the Frontal Area (m²).

UTILIZATION OF CYCLOPS

To find information and assistance on open opportunities for payloads that desire to use ISS, as well as details regarding the ISS payload integration and safety processes, payload developers can visit http://www.nasa.gov/mission_pages/station/research/rsc_h_proposal.html and/or <http://www.iss-casis.org/>.

ACKNOWLEDGEMENTS

The Cyclops Project and its members appreciate all the efforts and assistance of the ISS Program, the DoD STP

office, the NASA JSC Engineering Directorate and its engineering-support contractor organizations for their contributions in the areas of resources and finances, technical input, safety and integration which enabled the development and eventual successful operation of the Cyclops ISS satellite deployment system. The project’s success has also been due to the cooperation and support of the SpinSat and Lonestar teams for patiently assisting in the development of a satellite deployment system that accommodates their needs as well as those of future satellite users. Special gratitude is also extended to the Japan Aerospace Exploration Agency for their extensive collaboration in assisting the Cyclops’ team in ensuring the integration and operation of Cyclops with their JEM airlock and robotic systems.

REFERENCES

1. Hershey, Matthew P., Newswander, Daniel R., James P. Smith, Craig R. Lamb and Perry G. Ballard, “Paving the Way for Small Satellite Access to Orbit: Cyclops’ Deployment of SpinSat, the Largest Satellite ever Deployed from the International Space Station” *Proceedings of the 29th Annual AIAA/USU Conference on Small Satellites*, Logan, UT, August 2015.
2. Wiens, Kyra, “Space Station Astronauts Launch SpinSat; NRL Starts Getting Data.” *United States Naval Research Laboratory*. Disqus, 12 Jan 2015. Web. 6 June 2015.
3. Newswander, Daniel R., James P. Smith, Craig R. Lamb and Perry G. Ballard, “Space Station Integrated Kinetic Launcher for Orbital Payload Systems (SSIKLOPS – Cyclops)” *Proceedings of the 27th Annual AIAA/USU Conference on Small Satellites*, Logan, UT, August 2013.