

ATLAS Beam Steering Mechanism Lessons Learned

Kenneth A. Blumenstock*, Alexander K. Cramer*, Alan B. Gostin*, Claef F. Hakun*, Paul G. Haney*, Matthew R. Hinkle*, Kenneth Y. Lee*, Carlos F. Lugo*, Adam J. Matuszeski*, Armando Morell*, Nerses V. Armani**, Joseph Bonafede**, Molly I. Jackson**, Peter J. Steigner** & Juan J. Stromsdörfer**

Abstract

This paper describes the design, testing, and lessons learned during the development of the Advanced Topographic Laser Altimeter System (ATLAS) Beam Steering Mechanism (BSM). The BSM is a 2 degree-of-freedom tip-tilt mechanism for the purpose of pointing a flat mirror to tightly control the co-alignment of the transmitted laser and the receiver telescope of the ATLAS instrument. The high resolution needs of the mission resulted in sub-arcsecond pointing and knowledge requirements, which have been met. Development of the methodology to verify performance required significant effort. The BSM will fly as part of the Ice, Cloud, and Elevation Satellite II Mission (ICESat II), which is scheduled to be launched in 2017. The ICESat II primary mission is to map the Earth's surface topography for the determination of seasonal changes of ice sheet thickness and vegetation canopy thickness to establish long-term trends.

Introduction

The primary purpose of this paper is to focus upon "Lessons Learned" that came about during the development of the ATLAS Beam Steering Mechanism (BSM). A secondary purpose is to review the configuration and design features of the BSM, as well as to gain understanding of the reasoning behind some of the design features.

Light, Detection, and Ranging (LiDAR) systems have been used for numerous spaceflight missions. High-powered laser pulses fired from the spacecraft are reflected off the Earth's surface and back to the spacecraft, where they are detected. Measurement time from firing to detection determines the distance to the surface, and signal characteristics reveal additional properties of the atmosphere and surface. ATLAS maps the topography of our planet to monitor seasonal changes in ice sheet and vegetation canopy thickness, which is very important in gaining understanding of long-term trends.

As technology advances, there is always a desire to gain better resolution of measurements. ATLAS has the smallest transmitted beam, smallest receiver field of view, and smallest alignment margin among NASA/GSFC space-borne laser altimeters. This resulted in the stringent requirements imposed upon the BSM, which led to further challenges in verifying that those requirements were met.

Design

Overview

An exploded view of the BSM is in Figure 1. Not shown in that figure are both the actuators and the position sensors, which can be seen in the cross sections of Figure 2.

Mirror

The BSM mirror, which reflects a high-powered laser, required a dielectric coating to provide very high reflectivity at the wavelength of the laser. A metal mirror would not support a dielectric coating, resulting in

* NASA Goddard Space Flight Center, Greenbelt, MD

** Stinger Ghaffarian Technologies Inc., Greenbelt, MD

lower reflectivity, causing more heat on the mirror, thus degrading figure requirements. For a dielectric coating a glass substrate is required, coated on both front and back of the mirror to cancel stresses.

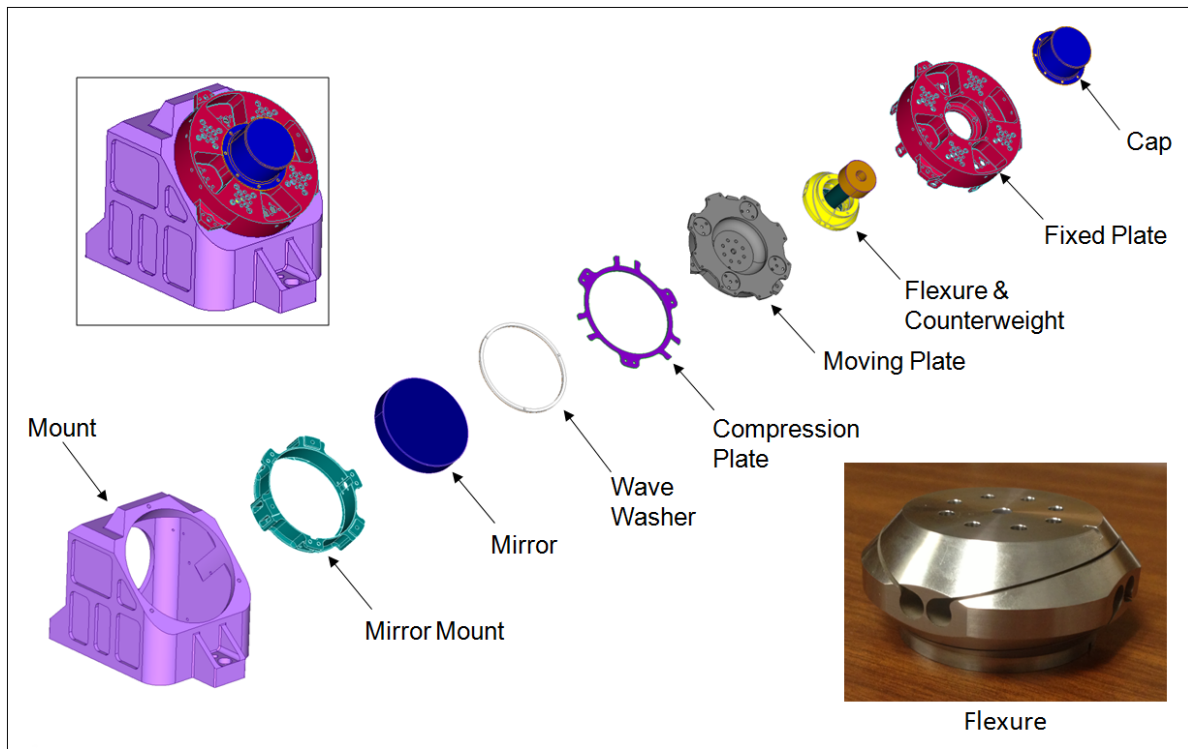

Figure 1. BSM Exploded View

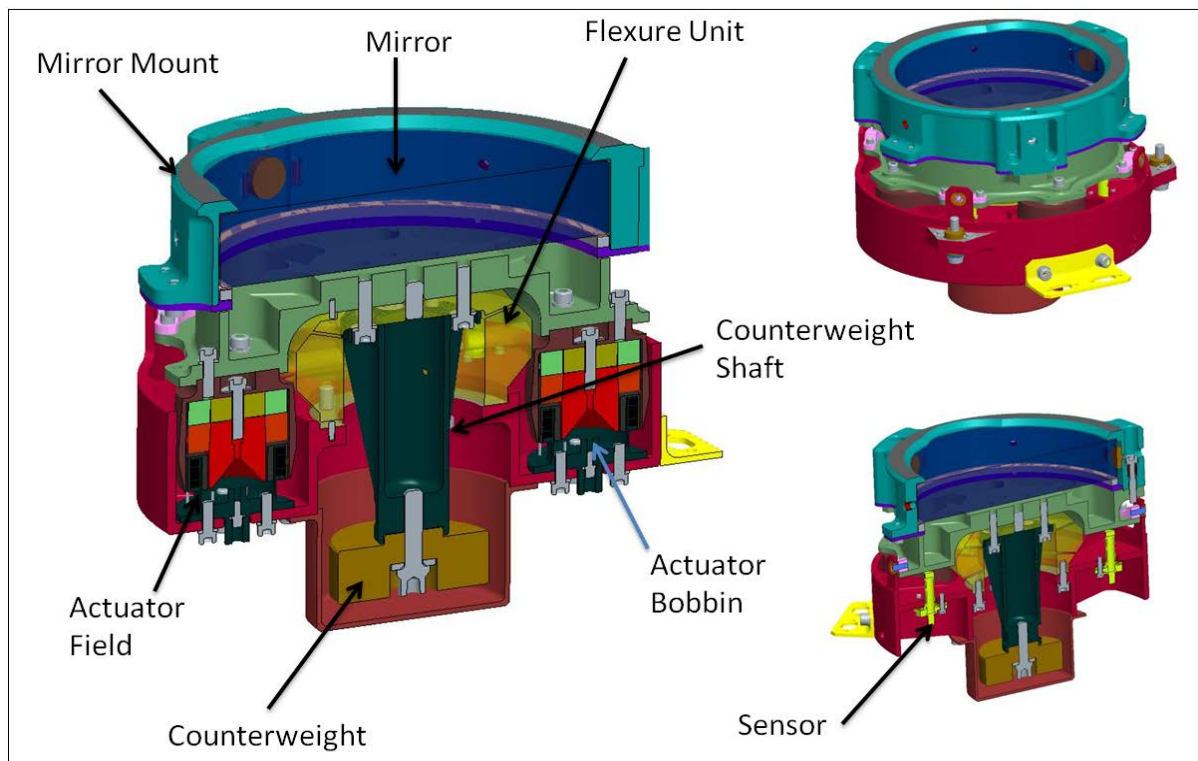

Figure 2. Cross Sections

To meet figure requirements, a rather thick mirror was required, resulting in a significant mass. This mirror mass was a significant design driver. An increase in mirror mass results in the need for a larger counterbalance mass, together increasing the total moving mass. The total moving mass is supported by the flexures, which need to survive launch loads without degradation.

Flexures

The flexures were electrical discharge machined from conventionally machined titanium. Arrangement of the flexures allows the mirror to rotate about two orthogonal axes. Finite Element Method (FEM) structural and modal analysis was used to trade structural mode frequencies to determine the optimal flexure geometry. Flexures were designed to keep stresses within levels to result in infinite life.

Actuators

A pair of voice coil actuators is used to control each axis. The actuators were of an in-house custom design to achieve high efficiency, utilizing a high-performance cobalt-iron alloy along with an arrangement of axial and radial magnets. Cobalt-iron shaping put most of the cobalt-iron near saturation, saving mass. The actuators have redundant windings, with a primary winding in the bobbin center and a secondary winding split inner and outer of the primary winding. This arrangement equalized actuator performance of primary and secondary windings. Equalizing was needed as a result of the air gap magnetic field drop when moving away from the magnet side of the actuator. High damping was incorporated by the inclusion of a copper damping sleeve as a part of each actuator.

Damping

High damping adds greatly to the disturbance rejection capability of the system. Disturbances can originate externally, as a result of jitter from momentum wheels and other sources propagating through the spacecraft structure; or internally, from electrical noise or quantization error in the control system. Damping can be provided by closing a velocity loop, which does not have to waste power to overcome the damping during slew operations.

Implementing a velocity loop, however, results in several issues, including the need for a very sensitive velocity sensor to detect low velocities, and could even result in decreased pointing stability as the result of added electronics noise. Such architecture could result in a very large and heavy velocity sensor with very fine, non-robust wire to achieve a high turn count, and might require pre-amplification near the sensor. Deriving velocity from a position sensor also has its limitations, especially when trying to sense low velocities.

Passive damping with a shorted coil, such as a solid copper sleeve, can waste power when slewing. In the case of the BSM, operational mirror velocities are very small, thus there is insignificant impact upon operational power required to overcome shorted coil passive damping. Thus, shorted coil damping was implemented in the BSM actuator design. Figure 3 shows actuator cross section and component views.



Figure 3. BSM Actuator Cross Section, Bobbin Assy., and Bobbins with Sleeves

Damping also proved very useful for minimizing loads during launch. The mirror is free to move until hard stops are contacted. Much of the energy is absorbed by the passive damping. This prevented the need for implementation of a launch lock mechanism.

Position Sensors

Differential Impedance Transducer position sensors were chosen from Blue Line Engineering. A pair of sensors was used to sense the angle of each axis. Sensor targets were located on the rotation axes as one function of the aluminum "moving plate," to which the mirror mount assembly attaches. The surface was machined to be planar. Keeping the targets close to the rotation axis minimizes target translation, which is a source of sensor error. Ensuring a planar surface minimizes sensor error that would result from target translation.

Modal Considerations

Precision pointing mechanisms require closed-loop control for fast response and required disturbance rejection, which results in the need for high controller bandwidth. It is of critical importance to design the mechanism such that its structural modes are compatible with the controller bandwidth--typically the minimum structural mode must be several times the controller bandwidth frequency. However, high Q modes (high amplitude modal peak) may need to be farther from the controller bandwidth frequency, and lower Q modes could be closer. Also, modes that are in a different direction than the controlled direction might be less of a problem. It is difficult to accurately assess how the structural modes will affect performance until after the hardware is built.

All mechanism components were analyzed for modal frequencies, with the goal of keeping those frequencies to at least four times the controller bandwidth of 70 Hz. In some cases, it was not practical to achieve modal frequencies of four times the controller bandwidth. Most exceptions were modes that analysis showed to be occurring in directions other than in directions that the mirror is controlled.

Thermal Stability

Absolute position knowledge required tight thermal stability, dictating the mechanism materials. The BSM Engineering Model had an aluminum structure that mounted onto an aluminum housing. The housing interfaced with a composite bench with titanium inserts. Analysis found thermal instability to be greater than acceptable, so the housing and BSM structure material was changed to titanium for the BSM Flight Model. So, all is titanium up to and including the flexure. The moving side of the flexure comprises the moving plate and the mirror mount, all of which are aluminum. The titanium flexure to aluminum moving plate interface, with its symmetrical and small diameter connection, did not pose any thermal interface issues.

Lessons Learned

Overview

Various issues came about during the development of the BSM, as happens with any engineering development. Most issues were resolved in short order. Some of these issues and their lessons learned will be discussed. For this project, verification of requirements was a major focus throughout the development, which will be touched upon.

Performance Verification Challenge

Performance verification required a high data sample rate along with highly accurate dynamic measurements over the operating environment, so it was determined that a lab interferometer would be a necessary verification instrument. However, due some measurement non-linearity errors resulting from BSM mirror properties being incompatible with the laboratory interferometer wavelength as well as temperature stability issues of the set-up, static measurements were employed to compensate for these shortcomings. Thus, utilization of multiple measurement instruments along with a data acquisition approach was devised and successful requirements verification was achieved. Pre-planning of the data acquisition approach and the proposed data reduction methods were approved by the project science team early on, paving the way for a very successful outcome.

Verifying the BSM pointing requirements necessitated the use of three separate optical references: a three-axis displacement-measuring interferometer from the Zygo Corporation, a Leviton Inter-target Differential Electronic Autocollimator (IDEA), and a Leica T3000 Theodolite. There was no single metrology solution that could provide high resolution, high accuracy, and absolute position verification over the BSM mirror's full range of motion. Rather, it was necessary to utilize information from multiple reference instruments in order to verify the requirement.

The Zygo interferometer setup consisted of a 3-axis High Stability Plane Mirror Interferometer, driven by a Zygo laser and measured by a Zygo ZMI4100 measurement board (Figure 4). This setup provided both the highest time and spatial resolution, achieving a 10-kHz cadence and having an advertised resolution of just over 20 nanoradians. Unfortunately, its field-of-view (FOV) of ± 3 milliradians, compared to the 5.6 milliradian range to be measured, resulted in the need to realign the interferometer to capture the full FOV. The pitch axis was prone to significant non-linearity, in part caused by a polarization effect of the BSM mirror's dielectric coating, which was tuned to the 532-nm ATLAS laser, but not the 633-nm Zygo laser wavelength. This non-linearity meant that only the yaw axis data of the Zygo was trusted, and led to inconveniently taking Zygo measurements of both BSM axes using only the Zygo yaw axis. The Zygo has no reference, so is not an absolute, but rather is an incremental sensor. The characteristics of the Zygo made it impractical for TVac testing, but it was extensively used for the bulk of testing.

The IDEA autocollimator has a FOV of roughly ± 10 milliradians, is very compact and lightweight, has a very high accuracy of 2.5 microradians, and is very stable. IDEA makes use of a reference flat to measure against, which minimizes measurement drift, making it an absolute measurement instrument. No optical adjustments are required to measure the difference between the reference flat and the mirror of interest, which in this case was the BSM Mirror. An aperture select mechanism is required to alternate IDEA's view between the reference flat and the BSM mirror. The IDEA characteristics made it ideal for measuring thermal stability during Thermal Vacuum (TVac) (Figure 5), though it was also used for non-TVac testing. IDEA is a low bandwidth device, able to achieve a maximum cadence on the order of 5 Hz.

The theodolite offered similar performance as IDEA, though large and bulky, but unlike IDEA, it required manual operation for each measurement. Theodolites have significantly more heritage as an optical reference than IDEA, which is a fairly new development not yet commercially available. Measurements taken with a theodolite were used to determine the BSM sensor scale factors and axis orientation.

Optical measurements during TVac were taken using IDEA, whose wider FOV could tolerate gross motion of the BSM mount due to temperature changes in the vacuum chamber. IDEA measurements were used to make temperature-dependent adjustments to the scale factor, determined before TVac. Performance over the full range was quantified using interferometer data which had been post-processed to remove non-linearities. Processing a combination of data from these three instruments verified BSM pointing performance over its full required range of motion and temperature.

The photo of Figure 6 shows optical references used by the measurement instruments. The BSM cube was used by the theodolite as a position reference. The reference flat was used by IDEA as its position reference.

As position knowledge and pointing requirements for similar systems in the future become more demanding, verifying these requirements will require not only the synthesis of measurements from multiple references, but also deep understanding of the limitations of each reference chosen.

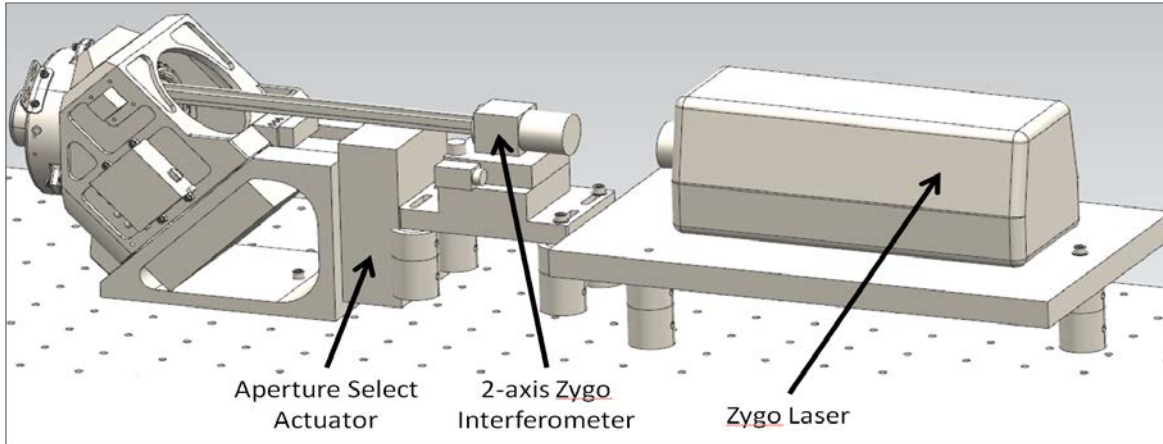

Figure 4. Interferometer Setup

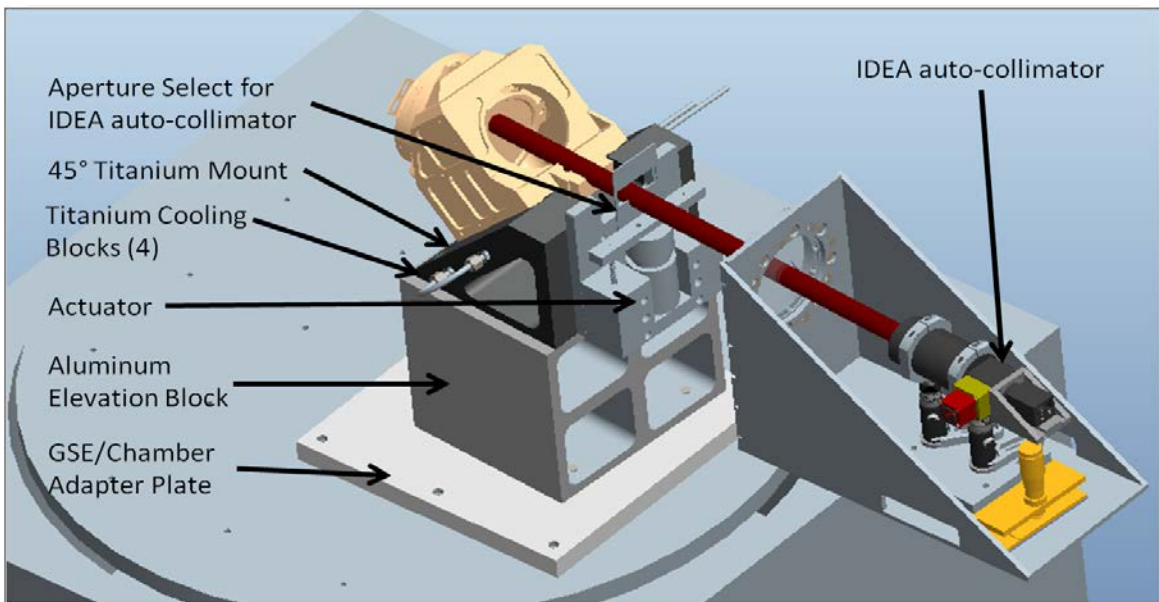

Figure 5. TVac Configuration Using IDEA

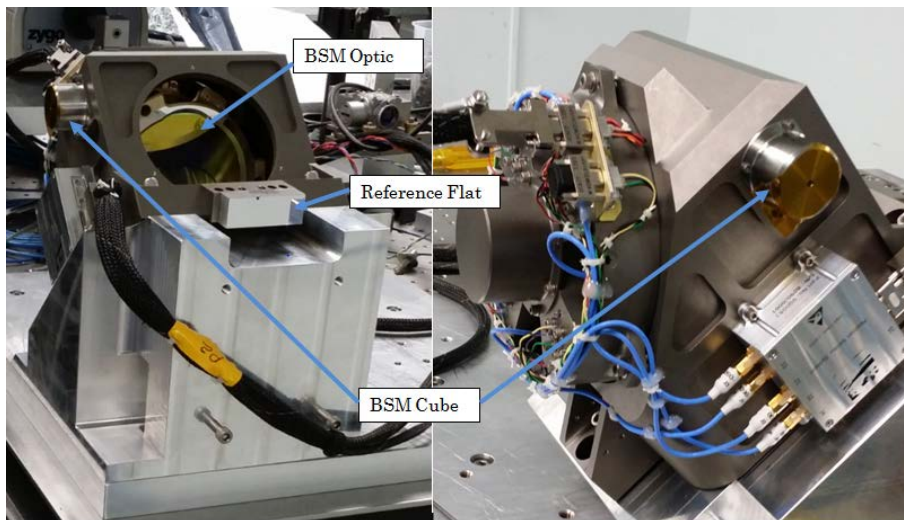

Figure 6. BSM Optic and Optical References

Initial Inconsistent Performance

When the BSM Engineering Model was available for testing, it was mounted to an optical bench and initial frequency response testing was performed. The controls engineers were finding inconsistency upon taking successive frequency responses and it was further found that changing the torque of the mounting hardware changed those responses. Due to the fact that proper hardware for mounting the BSM to the bench was not yet ready, the BSM housing was clamped to the bench using machine tooling. The surface of the honeycomb optical bench is made of a thin section of steel with threaded holes on 1-inch (2.5-cm) centers. There certainly was not concern over the stiffness of the bench that also happened to sit on a very thick granite table, which was floating on a seismic block. However, local attachment threaded holes did not provide adequate stiffness, thus affecting response measurements. The issue was eliminated by adding a half-inch-thick (1.3-cm) aluminum plate between the bench and BSM hardware.

Undesirable Structural Mode

Measurement of the frequency response found there to be a very undesirable structural mode near 900 Hz. While this frequency was quite far from the controller bandwidth, the mode had a very high Q, which made it troublesome. Very unusual was the wide frequency range of the base of this mode, such that it did not have behavior consistent with that of a structural mode. One of the controls engineers was able to implement filtering in order to deal with this mode, sacrificing some phase margin, but still leaving adequate phase margin.

Careful study was made of the modal analysis to determine the source of this behavior, but it is typical to find that modes revealed in the model do not match the measured modes. Using FEM modal analysis, we were unable to determine the source of this very troubling behavior. The modal analysis software tool does not specify an input location, or an output location. Furthermore, guesses are made to choose damping values for the materials to input into the analysis tool. In the physical world, the frequency response input is the current to the actuators, which becomes localized force inputs, and the frequency response output is the position sensor signal, which is the motion of the sensor targets. So, the modal analysis cannot be expected to give an accurate representation of the measured frequency response. We would be pleased to be made aware of analysis tools that can better predict frequency response for a mechanism with actuators and sensors intended for closed-loop control.

Certainly, management was concerned that effort was being expended to correct this modal behavior issue. The question was posed, "Do we meet requirements?" The answer was that we did on the bench, but the possibility of structural mode behavioral changes after integration, or even on-orbit, requires having capability to deal with such changes. The controls engineer had designed in the capability for a maximum number of poles for filtering, but with the unusual mode, there was risk that filter capability could be insufficient to deal with structural mode changes that might potentially come about.

We hit a dead end using FEM analysis, so we chose a brute force method to find out what was causing the troubling structural mode. The BSM does not have many parts. Trial and error changing of parts with modified parts was the technique implemented. Since the BSM required a rather heavy tungsten counterweight, it was theorized that a lack of stiffness of the titanium counterweight shaft could be responsible. The drawing was revised and parts were put into fabrication. After planned testing of the BSM Engineering Model was completed, the new and stiffer ribbed titanium counterweight shaft was installed. The new frequency response showed that the massive and wide structural mode was replaced by small, typical looking structural modes. Problem solved. The before and after open loop frequency responses (of mechanism and controller together) are shown in Figure 7.

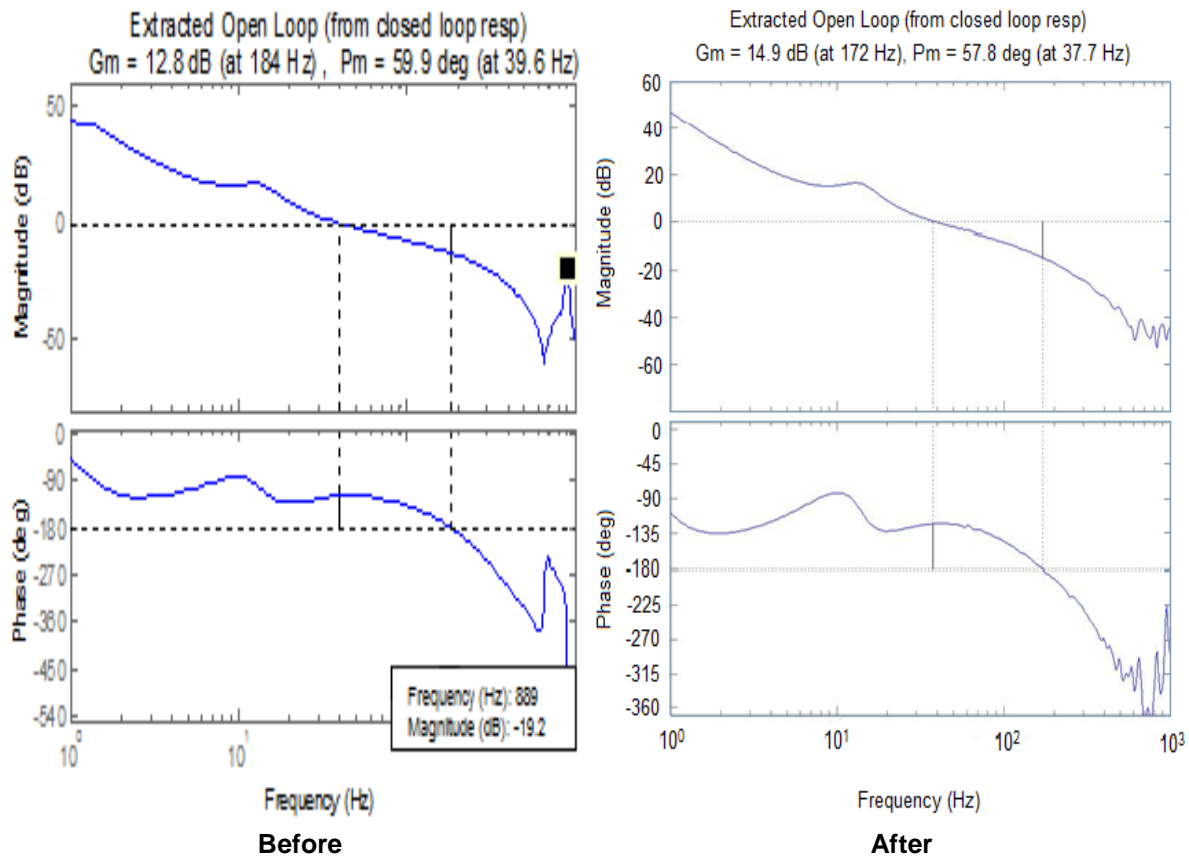

Figure 7. Frequency Response Before and After Counterbalance Shaft Change

Hipot Overtesting Failure

Qualification of the in-house voice coil actuators required high potential (hipot) and insulation resistance testing to be performed. We referred to one of our test specifications documents, and applied a test voltage of over 1000 volts, which resulted in a failed actuator winding. After investigation, it turned out that our test specifications were really intended to be used for cable and connector testing. Furthermore, we found out that lower voltages were regularly being used for most cable testing, more so for cables with miniature connectors. Since our operational voltage was no more than 12 volts, it was decided to test at 250 volts, after which all hipot and insulation resistance tests were passed without issue. So, the lesson learned is to not blindly follow documentation. We should have surveyed the standard practice for motor winding hipot and insulation resistance testing rather to follow a test specification that was not applicable. Another factor was that we were probably overly confident that our design was bullet proof. It is not prudent to overtest.

Undesirable Behavior of the Flight Model

The BSM Flight Model had completed its testing just at the point ready for environmental testing to begin. The controls engineers discovered puzzling behavior of the BSM Flight Model not seen in the BSM Engineering Model. When making mirror motions from one point to another, the trajectory would miss the commanded go-to point and then circle back before arrival to that point. While such behavior was always seen in the BSM Engineering Model, it was not seen at the magnitude observed in the BSM Flight Model. We were privileged to have one of our top technicians perform the assembly of all the BSMs. During our investigation, it was revealed that our technician observed an unusual behavior during the balancing process. The balancing process was dependent upon usage of the highly sensitive internal position sensors. The BSM Flight Model was mounted into a cubical framework that allowed the mechanism to be oriented with gravity in six different directions, two with the counterbalance shaft vertical, and four with the

counterbalance shaft horizontal, with vectors in plus/minus X, Y, and Z (Figure 8). Once balanced, changing the gravity vector direction by 180 degrees should not result in mirror positional changes. However, when checking balance in the X vector, the technician was observing changes in Y, and when checking balance in the Y vector, he was seeing changes in X.

Our technician was advised to not pay attention to changes in the axes he was not balancing since it would only create confusion in the balancing process. That instruction allowed the technician to complete the balancing, but we should have paid attention to the resulting magnitude of the non-gravity-aligned axis. We realized that changing the gravity vector by 180 degrees of what we believed to be a balanced BSM resulted in significant motion in the orthogonal non-gravity aligned axis. This was a very puzzling behavior.

If mirror motions were constrained to flex either one flexure or its orthogonal flexure, axes A and B, that motion would be rotated from the sensor axes X and Y by 45 degrees. The counterweight, its position location Z at the end of the counterbalance shaft, is adjusted by shims to achieve balance. However, flexure rotation locations on Z need to be identical. If flexure rotation locations are different, it is only possible to achieve balance upon one flexure axis or the other. A compromise could be made, such that one flexure axis would be mirror light and the other axis could be equally mirror heavy. The lack of co-alignment of the flexure axes with the sensor axes is important to understanding the behavior observed.

Refer to Figure 9 for the imbalance phenomena explanation that follows. Assume the balance is perfect and the Y axis is aligned with the gravity direction. The mirror will point to position 0 at the origin. Let us move one of the flexure axes in +Z to make the moving assembly mirror light, and then move the other flexure axis in -Z to make the moving assembly mirror heavy. Remember that the flexure axes A and B are such that mirror motion on either flexure axis A and B is constrained to be in a direction that is 45 degrees from the sensor axes. If looking from the back of the mirror along the counterbalance shaft, assume that the mirror light flexure axis A pointed the mirror up and to the right, following the blue arrow to position 1. Motion on the mirror heavy axis B would then be down and to the right, following the red arrow to position 2. The net result is that imbalance did not affect the Y sensor axis in the gravity direction, but rather, the net motion was to the right in the X horizontal, non-gravity-aligned axis, following the purple arrow from position 0 to position 2. It does seem counterintuitive that changing the gravity vector 180 degrees results in motion on an axis that is orthogonal to the gravity vector, yet such motion is an indication of imbalance. Had the flexure axes been aligned with the sensor axes, it would have been apparent that balancing one axis would result in the other axis not being balanced.

The root cause turned out to be that flexure manufacturing tolerances were not met, with the two flexure rotation locations separated in Z by about 0.009 inch (0.23 mm). Inspection reports were incorrect, due to improper fixturing and confusing geometric tolerances. New flexures needed to be manufactured, unfortunately resulting in significant schedule slip. Had there been better awareness of the behavior anomaly, we could have caught the issue sooner.

Unknown Pole

An unknown pole of 150 Hz was present in the frequency response, but was accommodated with filtering. The pole is unknown in that a MATLAB/Simulink model of the BSM, based upon the mechanical and electrical specifications, did not reveal such a pole. Similar behavior was observed on the Cassini Composite Infrared Spectrometer (CIRS) Scan Mechanism developed in the early 1990s, which also had damping designed into its custom actuator. Since in both cases, we needed to deliver hardware on a tight schedule and we were able to meet performance requirements with the extra pole, we moved forward. In both cases the project ended without the opportunity to spend the time to fully understand the physics behind the behavior. However, we believe the unknown pole to be the result of coupling between the actuator windings and the damping sleeve, which were arranged coaxially in both projects (Figure 10).

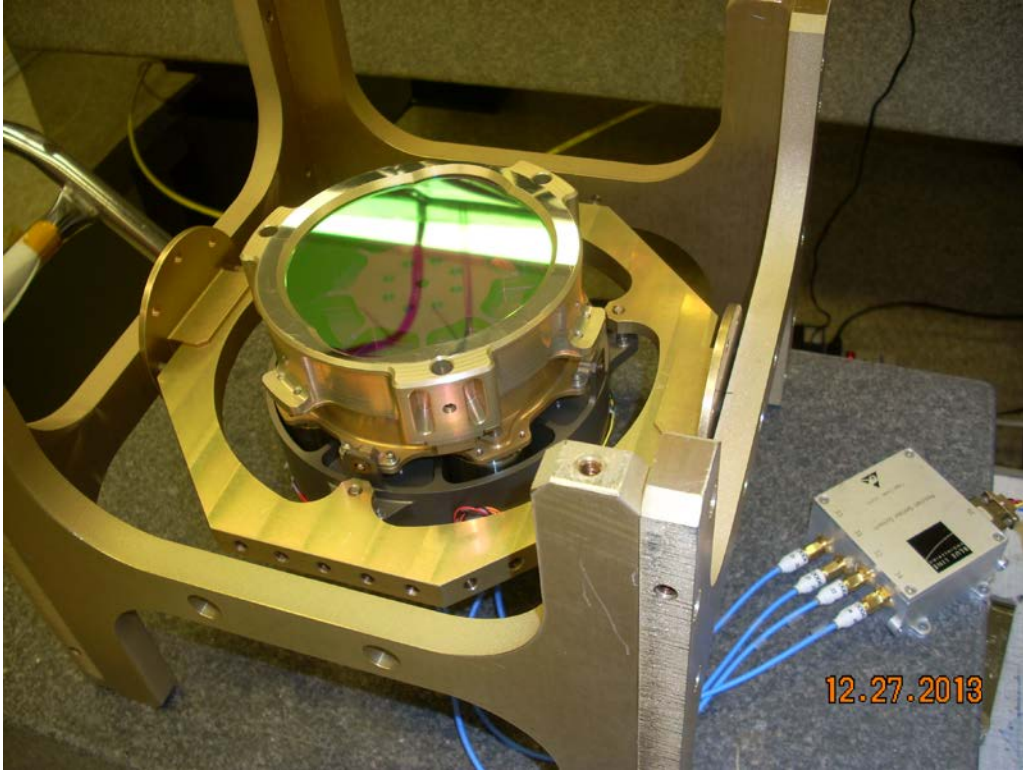

Figure 8. BSM Flight Model Mounted in the 6-Axis Balancing Fixture

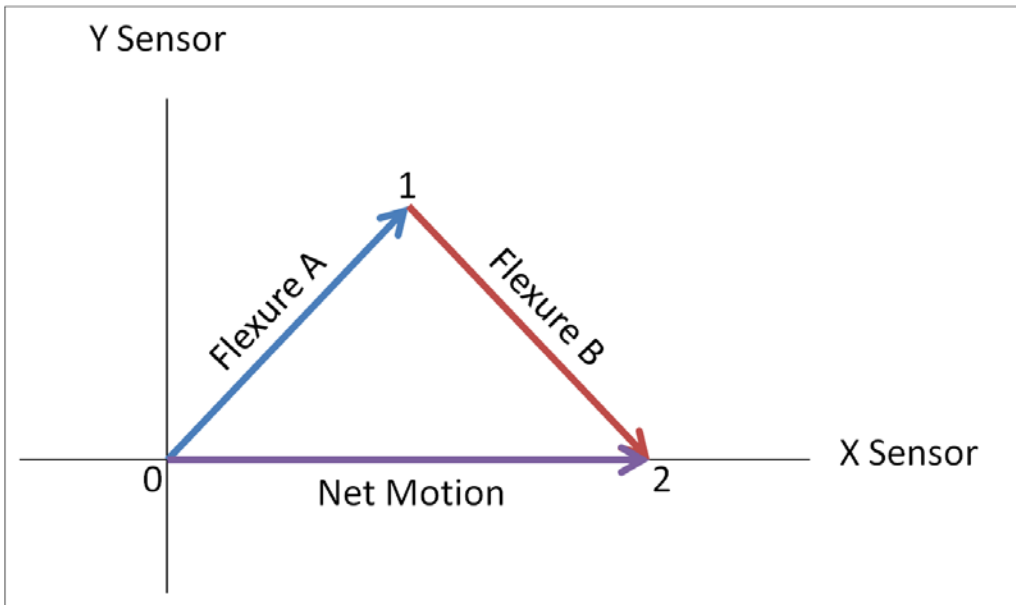

Figure 9. Imbalance Phenomena Explanation Graphic

We did design and fabricate actuator bobbins that separated the windings from the damping sleeves such that they would not be coaxial, but we never had the opportunity to test them. The more prevalent pole was the BSM, and the BSM was designed to have much greater damping than the Scan Mechanism, so it appears that there is a relationship between the amount of damping and the prevalence of the pole. If a non-coaxial design would reduce or eliminate the pole, phase margin could be greater resulting in reduced compensation output, better performance, and increased robustness.

Sensor Fabrication Issue

Our Differential Impedance Transducer sensors vendor, Blue Line Engineering, did an excellent job of providing sensors to meet our specifications. The raw sensor behavior is non-linear, so the sensor electronics undergo a tuning process to trade off various performance parameters. The vendor was able to predict very well what they could achieve. We pushed them to the limits of what was achievable for our application and for their technology.

While the vendor certainly was under schedule pressure, there are usually multiple reasons for explanation of any mishap. An error occurred during manufacture of the flight sensors. The epoxy used for potting the cables into the sensor bodies did not cure, which was one of the final steps in manufacturing the sensors. The root cause was an error in computing the mass of the components that were mixed, so the mix ratio was incorrect. It was necessary to build a new set of sensors, resulting in a small schedule slip. The vendor was very responsive and manufactured a new set of sensors very quickly.

While samples of pucks were provided for all epoxy mixes for outgassing testing, this process did not alleviate the risk of an error, but would catch the error after it occurs. Since significant work was at risk if an error in mixing occurred, it would have been prudent to have more checks in place. One possibility could have been to use premixed epoxy stored at cold temperature that had already been tested for outgassing.

A process error such as this can always happen. This lesson is a reminder to elevate checks to prevent such errors, dependent upon the amount of rework that is at stake if a process fails.

Schedule Pressure

In more recent times, pressure to meet schedule and budget has come under higher levels of scrutiny than in the past. For this particular project, the in-house engineering team was turned on at the 11th hour to produce the entire mechanism from concept to flight. This put us on a tight schedule.

The BSM was initially determined to be supplied from a vendor, but the work was taken in-house after an environmental test failure. The project originally chose the vendor as a cost savings measure since it is more cost effective to buy already developed hardware than it is to develop hardware. However, it turned out that the vendor's hardware had design shortcomings such that flight qualification would require redesign, so the perceived cost savings evaporated. The project further benefited going in-house since BSM requirements were compromised in order to utilize the vendor's hardware, so once the work was brought in-house, optical requirements tightened up significantly.

Being on a tight schedule put us in the spotlight. Management was very concerned and preferred to have hardware sooner than later. Sometimes it is useful to develop some hardware early on to help with the design process if analytical methods lack fidelity, such that the easier path is to build and test. In this case, we determined that any early hardware development would not be of benefit, and also that early hardware development would hurt cost and schedule. Though management desired a quick hardware cycle, we were thankful that the team was permitted to take the necessary time to design and analyze to the degree deemed most efficient.

It takes time and effort to develop hardware. Significant time is expended for procurement and fabrication, followed by time and effort for assembly and testing. The proper approach is to do all your homework and design it right the first time. Ideally, changes to the Engineering Model should be minimal in the Flight Model.

Thus, schedule pressure should not be permitted to result in cutting corners in the design cycle. If by cutting corners in the design cycle, you don't get it right, there is likely not time to do it again. If major changes to the initial configuration are needed, it could result in the need for an additional hardware iteration before the flight build. It could also result in sticking with a troublesome architecture and suffering with performance issues throughout the development and beyond, adding to cost and schedule. Cutting corners in the initial design cycle is a risk not likely to be worth taking. Performing the necessary engineering analyses in the initial design cycle is of key importance in successfully developing hardware efficiently.

Conclusion

The team was very motivated to be tasked with meeting requirements not faced before. In the past, we have developed pointing mechanisms and scanners requiring arcsecond levels of pointing, but we never before developed hardware to meet sub-arcsecond levels of pointing. Pointing requirements were met with margin (Figure 11). If we used the BSM to point a laser from NASA/ARC to San Francisco International Airport, a distance of 40 km, we could keep the center of that beam on a dime.

Various lessons learned have been discussed. Most of the lessons learned dealt with problems that appeared and were in short order, understood and solved. However, throughout the BSM development, verification of pointing was a major focus. In particular, verification of systematic error throughout mission life, full range of motion, and full range of temperature, was extremely challenging. The details of the methodology used for pointing verification go well beyond the scope of this paper, requiring a paper solely on this topic.

Being challenged with each issue that arose, understanding the problem, and finding the solution, is what fulfills us as engineers as each team member can attest. The team is very proud of the BSM development and was recognized by upper management for the outstanding achievements of this very challenging task.

The BSM Flight Model was integrated into ATLAS as shown in Figure 12. The BSM location on ATLAS is identified in Figure 13.

Acknowledgements

Willie E. Barber, Gregory A. Bowers, William G. Bowers, Thomas L. Capon, Gene G. Gochar, Andrea O. Poulin, Joseph P. Schepis, and David S. Schwinger from NASA Goddard Space Flight Center, Eric L. Holt from Stinger Ghaffarian Technologies, Inc., Greenbelt, MD, and Douglas B. Leviton from Leviton Metrology Solutions, Inc., Boulder, CO.

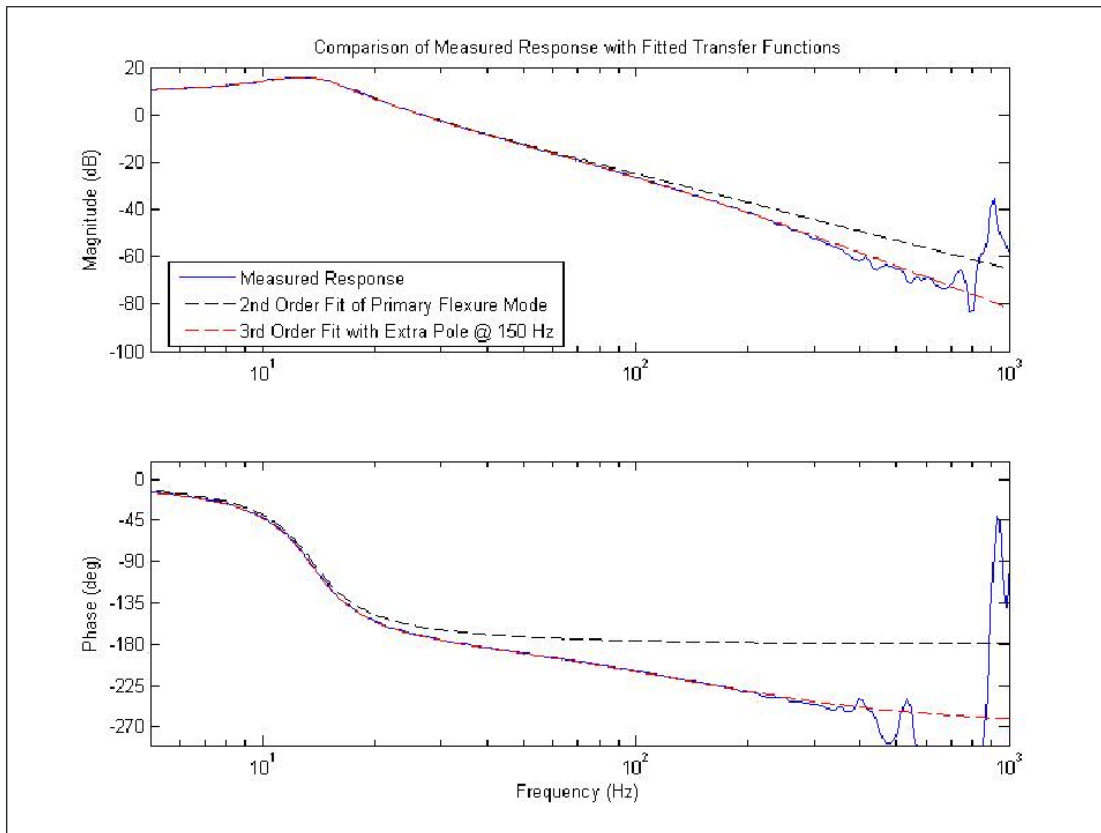

Figure 10. Unknown Pole

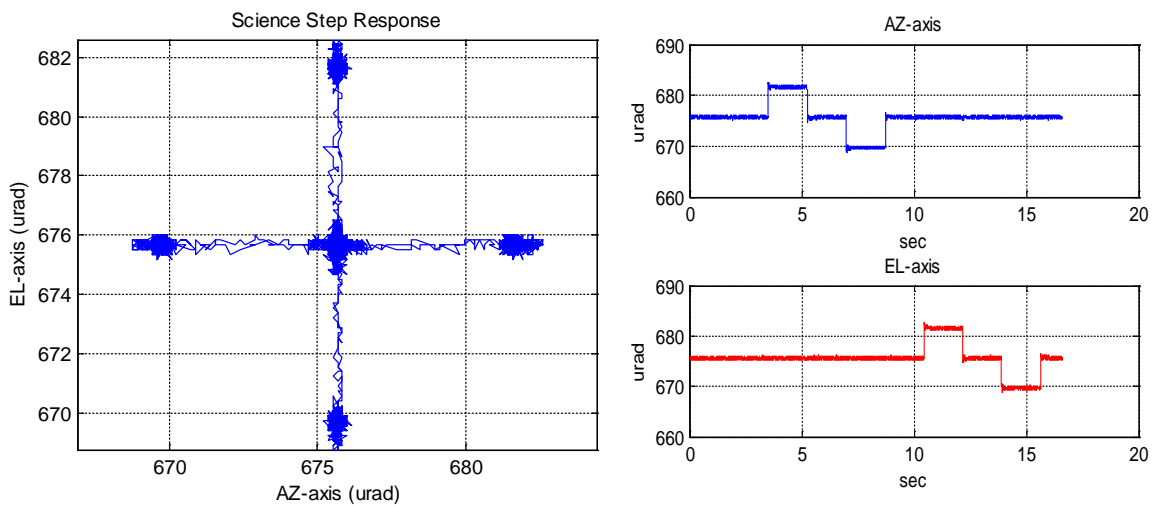

Figure 11. BSM Pointing Stability

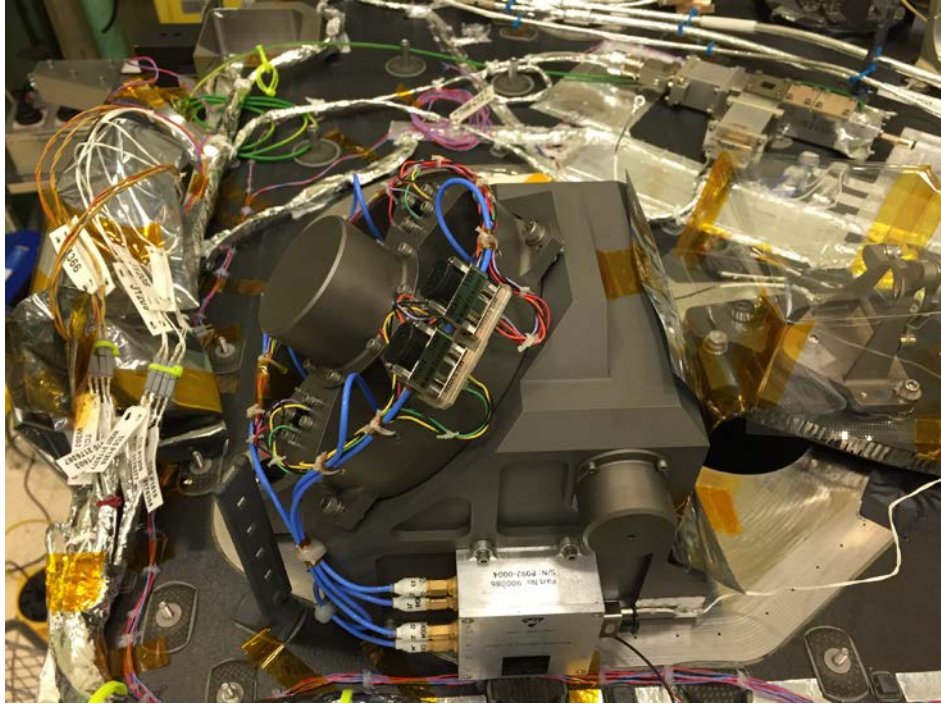

Figure 12. Initial Integration of Beam Steering Mechanism Flight Model onto the ATLAS Bench

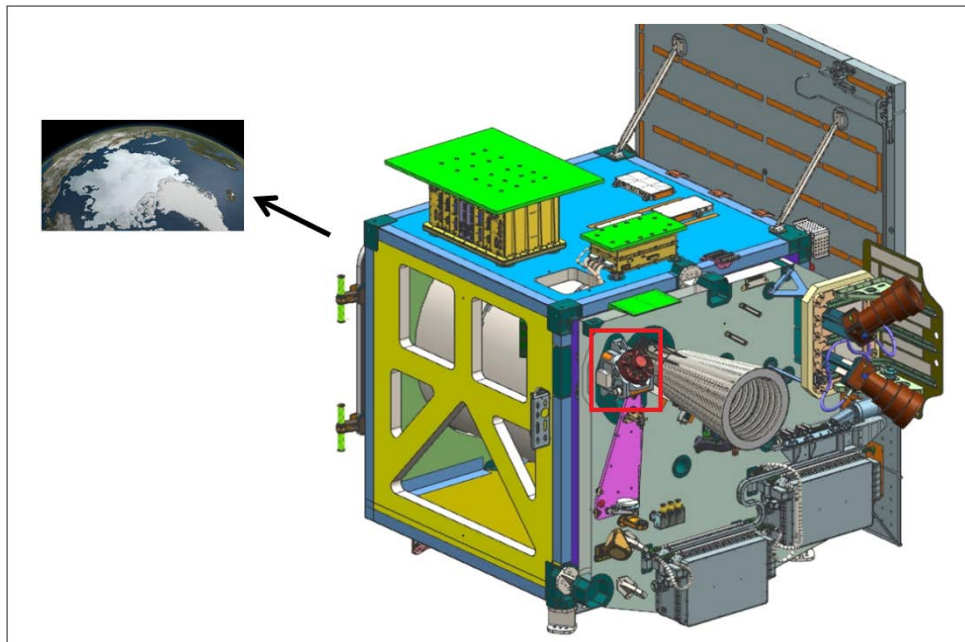

Figure 13. ATLAS Instrument with a Red Rectangle Indicating the BSM Location