

NASA-NIAC 2001 PHASE I RESEARCH GRANT

on

“Aneutronic Fusion Spacecraft Architecture”

Final Research Activity Report

(SEPTEMBER 2012)

P.I.: Alfonso G. Tarditi¹

Collaborators: John H. Scott², George H. Miley³

¹*Dept. of Physics, University of Houston – Clear Lake, Houston, TX*

²*NASA Johnson Space Center, Houston, TX*

³*University of Illinois-Urbana-Champaign, Urbana, IL*

Executive Summary

- Motivation

This study was developed because the recognized need of defining of a new spacecraft architecture suitable for aneutronic fusion and featuring game-changing space travel capabilities. The core of this architecture is the definition of a new kind of fusion-based space propulsion system.

This research is not about exploring a new fusion energy concept, it actually *assumes* the availability of an aneutronic fusion energy reactor. The focus is on providing the best (most efficient) utilization of fusion energy for propulsion purposes.

The rationale is that without a proper architecture design even the utilization of a fusion reactor as a prime energy source for spacecraft propulsion is not going to provide the required performances for achieving a substantial change of current space travel capabilities.

- Highlights of Research Results

This NIAC Phase I study provided led to several findings that provide the foundation for further research leading to a higher TRL: first a quantitative analysis of the intrinsic limitations of a propulsion system that utilizes aneutronic fusion products directly as the exhaust jet for achieving propulsion was carried on.

Then, as a natural continuation, a new beam conditioning process for the fusion products was devised to produce an exhaust jet with the required characteristics (both thrust and specific impulse) for the optimal propulsion performances (in essence, an energy-to-thrust direct conversion). The beam conditioning process was analyzed in details through modeling and simulation.

Another important development was the analysis of the characteristics of the direct energy conversion system (Travelling Wave Direct Energy Conversion, beam energy to electrical energy) was carried on. This system is required for both for electrical power supply of vehicle systems (including power that maybe re-circulated into the fusion core, likely a non-ignited fusion based concept) and for the first stage of the beam conditioning process.

Contents

1. Introduction

- 1.1 - A Game-Changing Concept
- 1.2 - Current Space Propulsion Limitations
- 1.3 - Fusion Propulsion
- 1.4 Differentiating from Fusion Research for Civil Power Applications
- 1.5 A Novel Architecture
- 1.6 Not Just Fusion
- 1.7 An Ambitious Goal

2. Background

- 2.1 Aneutronic Fusion
- 2.2 Fusion Core Flexibility
- 2.3 - Integration of Propulsion and Power
- 2.4 - Minimal Specific Mass

3. Research Results

- 3.1 Analysis of the Basic Aneutronic Fusion Propulsion Architecture
 - 3.1.1 Propulsion Directly from Fusion Product Exhaust
 - 3.1.2 Basic Estimate of Mission Capabilities
- 3.2 Direct Energy Conversion of Fusion Product Energy into Propulsive Thrust
 - 3.2.1 Beam Conditioning for High Thrust Exhaust.
 - 3.2.2 Further Enhancement on the Fast-Slow Bunch non-Thermal Interaction
- 3.3 Modeling and Simulation
 - 3.3.1 Basic Modeling of the Electrostatic Bunch-to-Bunch Interaction
 - 3.3.2 Particle-in-Cell Simulations
- 3.4 Direct Energy Conversion of Fusion Product Energy into Electrical Energy
 - 3.4.1 The TWDEC
 - 3.4.2 Basic Physics of the Energy Conversion in a TWDEC
 - 3.4.3 Modeling TWDEC Bunch-Electrode Coupling
- 3.5 Supporting Laboratory Experiments
 - 3.5.1 Inertial Electrostatic Confinement Plasma Device
 - 3.5.2 Diagnostic Results from the IEC Plasma

4. Recommended Near-Term Research Directions

- 4.1. Identification of Critical Paths to Feasibility Demonstration
 - 4.1.1 Synergistic Approach
 - 4.1.2 Critical Research Directions
- 4.2 Bunch-to-Bunch “Pusher”
 - 4.2.1 Simulation Tools
 - 4.2.2 Production Runs

- 4.2.3 Experiments
- 4.2.4 Investigation of an Old Concept
- 4.3 Electron Neutralization/Ejection
 - 4.3.1 System-Level Analysis
 - 4.3.2 Experiments
 - 4.3.3 Partial Neutralization
 - 4.3.4 Nanoparticle Jet
- 4.4 High-Efficiency, High-Density TWDEC
 - 4.4.1 TWDEC Simulation
 - 4.4.2 Experiments
- 4.5 Fusion Product Collector/Collimator
- 4.6 Fission Hybrid Interim Concept

Conclusions

References

Appendix

1. Introduction

1.1 - A Game-Changing Concept

It can be easily argued that the most important factor in drastically changing the paradigm of space exploration is the development of a new, radically more effective in-space propulsion system. Every other technology development would appear merely incremental compared to that of a new propulsion paradigm that, for any given payload, could increase the ratio of mission distance to trip time by a factor of ten or more.

Therefore, while looking for a revolutionary, visionary concept for space travel, it is difficult not to investigate the realm of new propulsion concepts. Indeed, a new propulsion paradigm, the object of this proposal, is the technology that could have the largest impact on NASA's mission capability.

1.2 - Current Space Propulsion Limitations

For deep-space travel, and for human space missions in particular (where the payload and trip-time requirements are significantly more stringent than for robotic exploration), the current state-of-the-art space propulsion appears largely inadequate.

Using the experience gained from the International Space Station, it can be concluded that a regular schedule of missions required for establishing and maintaining a human outpost away from the Earth orbit cannot be supported at any reasonable cost, even within the inner solar system. On the other hand, electric propulsion concepts offer an appealing potential in terms of shortening long-range space travel time, but their application on a large scale is critically dependent on the availability of a low-mass, multi-MW electric power source.

1.3 - Fusion Propulsion

For these reasons, the utilization of fusion energy for spacecraft propulsion may be one of the most compelling research directions for the development of the future space program. A fusion reactor with net power production capabilities has yet to be demonstrated, but fusion is no longer an exotic technology. It has reached a high level of scientific and technological maturity through a half-century of remarkable progress.

However, even if a fusion reactor were to be available today, its application to space propulsion must consider the proper integration with an electric thruster of some kind: overall system mass and efficiency are ultimately all that matter if a significant step-change in the potentials of space travel is to be achieved.

1.4 Differentiating from Fusion Research for Civil Power Applications

The design of a viable fusion reactor for civil power generation (such as the International Thermonuclear Experimental Reactor-ITER Program) is driven by engineering constraints and economic issues that are very different from those that must be considered in a space power system.

Thus, it would be unwise for the space community to wait for a power-utility-driven fusion reactor to become available before engaging in fusion developments tailored for space applications.

In fact, a large plasma confinement machine designed for deuterium-tritium fusion with neutron-to-electric heat engine conversion technology is unlikely to be suitable for space travel. Moreover, as the goal of a terrestrial power reactor is nearing reality, fusion research resources will likely be shifted away even further from the innovative/advanced fusion concepts that might enable “lighter” technologies and neutron-free electric power generation.

1.5 A Novel Architecture

The object of this research is to investigate the technical feasibility for a *novel direct fusion propulsion architecture* (Figure 1.5-1) that integrates an innovative beam conditioning/nozzle concept with a direct energy converter to obtain *propulsive thrust directly from the fusion products* of an aneutronic fusion core, without significant energy loss and ultimately enabling a new paradigm for human and robotic space exploration.

This effort is focused on the achievable overall spacecraft performance (integrating the power generation and propulsion systems) rather than on a specific fusion reactor concept development in order to identify paths in the parameter space that lead to optimal design, higher efficiencies, and mission-enabling solutions.

Fusion Energy to Thrust Direct Conversion

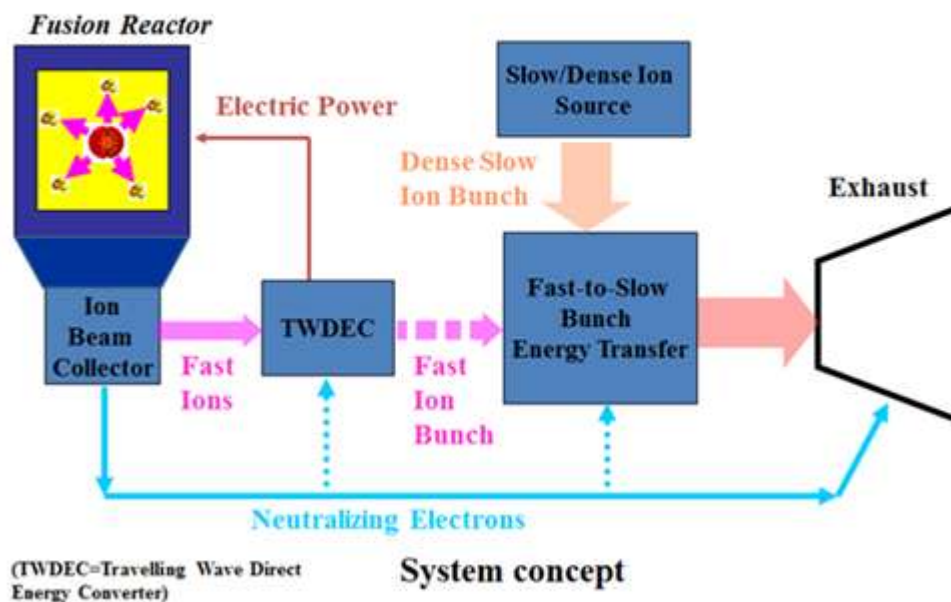

Figure 1.5-1. General scheme of the proposed architecture

1.6 Not Just Fusion

Furthermore, to provide a potentially advantageous *interim* option and not to be constrained by the immediate availability of fusion energy, the scope of this study includes the analysis of the utilization of a sub-critical fusion reactor (as part of a solar or nuclear fission-powered spacecraft) to replace “conventional” electric propulsion scheme, which might involve high-power plasma generation/acceleration.

1.7 An Ambitious Goal

This Phase I study is targeting a new spacecraft architecture to enable an unprecedented range of mission capabilities that, for the purpose of simple comparison, can be summarized as 10 times faster, 10 times further, and 10 times heavier with respect to the current state of the art. The improved traveling capabilities offer new, exciting mission possibilities and, in fact, an entire new paradigm for approaching the solar system exploration and colonization.

The development of the different components of the proposed architecture will require the exploration of new regimes for the physics of particle beam dynamics. However, this being a strong feature of the proposed concept, the outlined paths for reaching these different regimes of operation are based on existing technology and known physics. The concept has solid physics foundations and is characterized by credible engineering, not requiring out-of-the-ordinary investments.

The proposed architecture is currently in its early stage of development and of its maturing process and, provided that continuing support is obtained, can be projected to reach the time of practical utilization a decade down the line.

2. Background

2.1 Aneutronic Fusion

The best candidate for a truly neutron-free fusion is the proton-boron-11 reaction ($p-^{11}\text{B}$) [Glasstone, 1975], [Rostoker, 2003]. Due to the high relative collision energy required for obtaining a sufficient fusion yield from $p-^{11}\text{B}$, colliding-beam or non-thermal equilibrium plasma based schemes need to be considered [Rostoker,2002], [Rostoker, 2003].

The deuterium-helium-3 ($\text{D}-^3\text{He}$) reaction is also often considered for aneutronic fusion concepts. Its larger fusion cross section at lower collision energies (when compared to $p-^{11}\text{B}$) makes it technically more appealing. This advantage is partially offset by the fact that ^3He is quite rare and that if a significant number of collisions among deuterium nuclei occur, then neutrons will be generated from a D-D reaction. Moreover, energy is produced both as alpha particles and protons, requiring a somewhat more complex energy-conversion process (unless alpha particles are retained for the purpose of igniting a thermal plasma). If a scheme could be devised in which the collisions at high-energy occur only among the D and the ^3He particles, then the $\text{D}-^3\text{He}$ process becomes actually aneutronic.

Both of these options will be considered as part of exploring the parameter space to identify the most advantageous scenario. The optimal choice may change as incremental progress is made in fusion technology. However, the value to the proposed study remains, because the study is based on a parametric analysis where the fusion core is just one element of the overall fusion propulsion architecture.

2.2 Fusion Core Flexibility

This study is not focused on the specific process to make fusion a reality. Instead, it assumes an available fusion reactor (here also referred to as “fusion core”) that can produce a neutron-free flow of energy in the form of charged particles. The reference scenarios that are considered assume aneutronic fusion using the proton-boron 11 ($p-^{11}\text{B}$) reaction [Glasstone, 1975], [Rostoker, 2003] with Inertial Electrostatic Confinement (IEC, [Bussard, 1991], [Burton, 2003], [Miley, 2004]) and/or non-thermal plasma in a Field Reversed Configuration (FRC, [Tuszewski, 1989]). These are not, however, critical assumptions for the proposed work.

The proposed study will include the validation of options for a “sub-critical” fusion regime option. In this case, the fusion core is not able to produce more energy than it requires and is basically acting as a combined particle beam source and accelerator (electrical power is flowing in, and a particle beam at high energy is produced).

In this case, the focus is on how to properly design an overall system that is advantageous compared to a “conventional” plasma thruster, wherein electric power is utilized to generate, accelerate, and channel a plasma to form a suitable jet that produces thrust.

There is an immediate technological justification for this focus, because a fusion reactor with net energy yield (also referred as a “ $Q>1$ ” system, where Q is the useful power output divided by the required input power) does not exist yet. Moreover, this approach can effectively support research on

incrementally more competitive fusion-based propulsion systems, without being constrained by the requirement of immediate availability of a $Q>1$ fusion core.

2.3 - Integration of Propulsion and Power

The availability of a fusion reactor represents only a starting point of a technological process that leads to a paradigm shift in space propulsion. In order to achieve game-changing mission capability, a standalone aneutronic fusion reactor is not sufficient, nor is it enough to develop only an efficient advanced (electric) thruster. A deep integration of spacecraft power and propulsion management is required.

Overall, the key drivers are *low mass and high power* (achieving a *low overall dry mass* of the spacecraft architecture per unit of propulsive jet power produced). This is usually referred to as *specific mass* “ α ” and is typically expressed in kg/kW. The specific mass defines the basic figure-of-merit to be considered for evaluating any spacecraft architecture in terms of its mission capabilities [Moeckel, 1972].

2.4 - Minimal Specific Mass

The present study focuses on providing the framework required to make fusion propulsion an appealing proposition for long-range space travel. This objective requires the design of a propulsion architecture that ultimately minimizes α . Typically for “interesting” missions in the outer solar system, a value of α on the order of 1 kg/kW or less is required [Williams, 1996], [Miley, 1999], [Moeckel, 1972], [Jarboe, 2005], [Williams, 2001].

Ideally, to achieve the best efficiency with minimal components between power generation and propulsion, a fusion core should directly eject its reaction products into space in the direction of thrust. Thus, to reach this goal, the proposed research is investigating the feasibility of a system that allows direct conversion of the products of aneutronic fusion reactions into useful thrust. Direct conversion into electrical power sufficient to support the operation of the fusion reactor itself will be also considered.

However, due to the typically high energy of the fusion products (MeV range), if the products of aneutronic fusion reactions were utilized directly as propellant, the thruster would provide, at best, a propulsive jet with a speed (or specific impulse) that is excessively high for most practical missions (in particular for the exploration of the solar system).

3. Research Results

3.1 Analysis of the Basic Aneutronic Fusion Propulsion Architecture

3.1.1 Propulsion Directly from Fusion Product Exhaust

This study is focused on aneutronic fusion propulsion since the nuclear reaction involved are producing energy in the form of a charged particle flux and charged particles are required for direct conversion. A “conventional” ignited D-T plasma would produce energy in the form of a neutron flux from which energy can only be extracted by heating a fluid followed by a “heat engine” conversion into electricity, a process that would produce an efficiency penalty, as compared to the direct conversion.

The most straightforward approach to aneutronic fusion propulsion is to collect and collimate the reaction product particle flow (in general isotropic) and re-direct it in the direction for thrust.

For the p-¹¹B aneutronic fusion reaction (the best “truly aneutronic” candidate) the energy of the α -particle products is in the order of 3 MeV. This gives an α -particle ejection speed of about $1.2 \cdot 10^7$ m/s like. Assuming a 100 MW net fusion power output, there will be a flow of about $2 \cdot 10^{20}$ particles/s carrying this power. The thrust T that this flow can produce is equal to the mass flow (kg/s) times the speed (assuming the ideal case of laminar flow). The mass flow for α -particles is $7 \cdot 10^{-27}$ kg/particle $\cdot 10^{20}$ particles/s = $7 \cdot 10^{-7}$ kg/s. The resulting thrust is then $T = 7 \cdot 10^{-7}$ kg/s $\cdot 1.2 \cdot 10^7$ m/s ≈ 8 N and the specific impulse is $I_{sp} \approx 1.2 \cdot 10^6$ s.

3.1.2 Basic Estimate of Mission Capabilities

The mission capabilities for deep-space travel can be quickly estimated in the gravity-free approximation ([Moeckel, 1972], valid in conditions where the spacecraft acceleration is much larger than the local gravity acceleration).

As an example, a Mars rendez-vous trip is considered. For a constant acceleration in gravity-free environment the choice of the desired trip time determines the maximum peak velocity that needs to be achieved (“delta-v”).

Following [Moeckel, 1972] and assuming an initial spacecraft mass (high Earth orbit) of 350 metric tons (mT) and a final (payload) mass of 35 mT, it can be shown (Appendix) that a constant acceleration, variable specific impulse 50 days trip to Mars, will require a maximum specific impulse of 5300 s, and an initial thrust of about 13000 N.

From this example it is clear that the direct utilization of the fusion product in the propulsive jet exhaust does not fit the required scenario. To generate a thrust in the order of 10,000 N with the specific impulse provided by the 3 MeV α -particles a jet power more than three order of magnitude larger than in the example of section 3.1.1 is required, i.e. more than 100 GW, clearly beyond any feasible projection at this time.

In summary, the aneutronic fusion reaction products, due to their high kinetic energy (MeV range), cannot directly provide a propulsive jet with a speed (or specific impulse) suitable for most practical missions (in particular for the exploration of the solar system).

3.2 Direct Energy Conversion of Fusion Product Energy into Propulsive Thrust

The previous considerations led to the exploration of alternatives that would allow to increase the thrust and to decrease the specific impulse without incurring in significant power losses. In other words, a proper conditioning of the flow of fusion products should be implemented in order to meet the optimal propulsion constraints with minimal energy loss.

3.2.1 Beam Conditioning for High Thrust Exhaust.

The charged particles flow from aneutronic fusion reactions is assumed to have been collected and magnetically channeled into a unidirectional beam.

The first step consists in guiding the ion beam through a traveling-wave direct energy converter [Momota, 1992].

This conversion produces some amount of electrical power (as it may be required for the steady-state operation of the fusion core) but also produces a *bunching* pattern in the beam. A solenoidal magnetic field guides the (fast) ion bunches to approach a slower, denser ion bunches that are injected separately.

Electrostatic energy exchange causes the fast bunch to slow-down and the slow one to speed up, eventually producing a beam with increased mass flow and lower speed in the direction of propulsion and thereby achieving the lower specific impulse and higher thrust required meet mission design parameters (Figure 3.2.1-1).

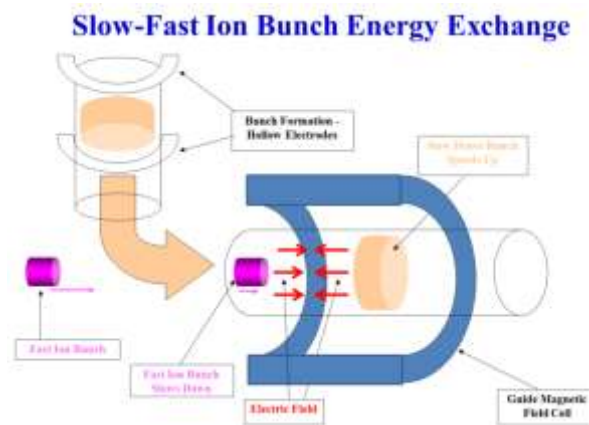

Figure 3.2.1-1- Conceptual scheme for fast to slow bunch interaction

3.2.2 Further Enhancement on the Fast-Slow Bunch non-Thermal Interaction

A traveling wave magnetic field approaching a slower (or stationary) particle bunch could in principle be utilized as an accelerator. This concept was illustrated for example in [Kunkel, 1966] as a “magnetic piston”. In order to produce this effect the α -particles are first injected with a large angle w.r.t. the axis of a solenoidal magnetic field: the longitudinal speed will be then reduced and particles will follow a spiral orbit (Figure 3.2.2-1). For example, for a 1 T magnetic field the gyro-radius of a 2.9 MeV α -particle is about 0.25 m.

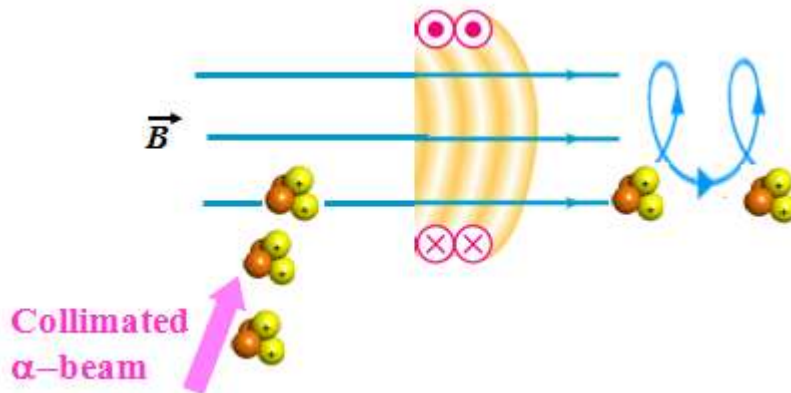

Figure 3.2.2-1 - Formation of the “magnetic piston”: are injected in a solenoidal magnetic field

Since the particles of the beam are already arranged in “bunches” a non-adiabatic mechanism to capture the ions can be realized by imposing a local fluctuation of the magnetic field in synchronization with the incoming bunches.

As the particle bunches are captured by the magnetic field a hollow cylindrical current layer is formed: with sufficient current build-up the increased magnetic field can push the “target” slower particle bunch (Figure 3.2.2-2).

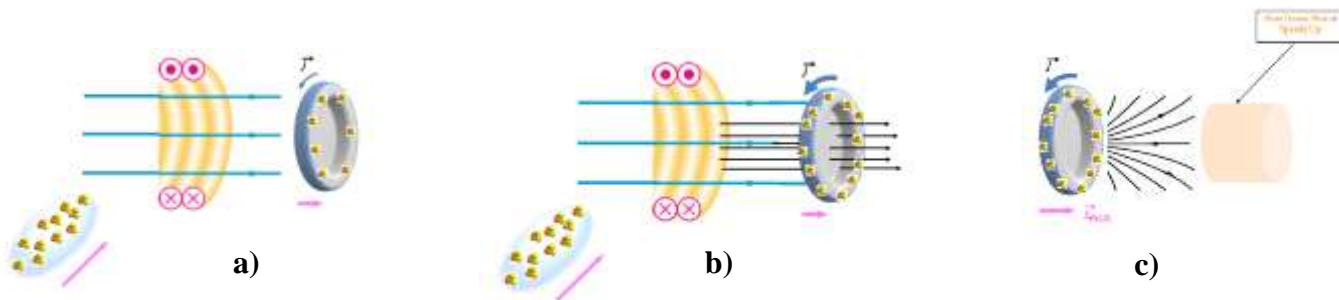

Figure 3.2.2-2 - Formation of the “magnetic piston”. a) Formation of current layer in a cylindrical shape b) As more particles are collected the current in the layer increases that, in turn, increases the magnetic field. c) The moving layer approaches and pushes the bunch.

3.3 Modeling and Simulation

3.3.1 Basic Modeling of the Electrostatic Bunch-to-Bunch Interaction

The basic process that allows to transform a high-specific impulse, low-thrust beam into a lower specific impulse, higher-thrust one is based on the electrostatic interaction of particle bunches. In this context a basic model can describe the interaction between two bunches for the purpose of guiding more accurate modeling through computer simulation.

The model considers a "fast" bunch approaching a "slow" bunch. The fast bunch has particle velocity v_f , density n_f , mass m_f , charge q_f , radius R_f length L_f . For the "slow" bunch, the same notations are considered with the change the index from "f" to "s".

The total charge on the fast bunch (assuming a cylindrical shape)

$$\text{will be } Q_f = q_f \cdot n_f \cdot \pi \cdot R_f^2 \cdot L_f$$

A similarly expression can be written for the charge Q_s of the slow bunch.

$$\text{The total mass of the fast bunch will be } M_f = m_f \cdot n_f \cdot \pi \cdot R_f^2 \cdot L_f$$

and a similar expression holds for the total mass M_s of the slow bunch.

The two bunches have (center of mass) coordinated $z_f(t)$ and $z_s(t)$ and all their particles are considered lumped together ("billiard ball" model).

The electric field acting on the fast bunch is produced by the slow bunch charge Q_s , and vice versa. The repulsive force due to the electric field E_f on the fast bunch will be (note the minus sign in front of Q_s):

$$F_f = M_f \cdot \frac{d^2}{dt^2} z_f(t) = Q_f \cdot E_f = Q_f \cdot \frac{-Q_s}{4\pi \epsilon_0 \cdot (z_f(t) - z_s(t))^2}$$

and similarly (now without minus sign)

$$F_s = M_s \cdot \frac{d^2}{dt^2} z_s(t) = Q_s \cdot E_s = Q_s \cdot \frac{Q_f}{4\pi \epsilon_0 \cdot (z_s(t) - z_f(t))^2}$$

The last two equations can be re-written as:

$$\frac{d^2}{dt^2} z_f(t) = Q_f \cdot E_f = \frac{-Q_s \cdot Q_f}{M_f \cdot 4\pi \epsilon_0 \cdot (z_f(t) - z_s(t))^2}$$

$$\frac{d^2}{dt^2} z_s(t) = Q_s \cdot E_s = \frac{Q_f \cdot Q_s}{M_s \cdot 4\pi \epsilon_0 \cdot (z_s(t) - z_f(t))^2}$$

By subtracting the last two equations it is found:

$$\frac{d^2}{dt^2} (z_s(t) - z_f(t)) = \frac{1}{(z_s(t) - z_f(t))^2} \cdot \frac{Q_f \cdot Q_s}{4\pi \epsilon_0} \cdot \left(\frac{1}{M_s} + \frac{1}{M_f} \right)$$

By defining $\xi(t) = z_s(t) - z_f(t)$ and equation for the evolution of the relative distance between the two bunches can be written as:

$$\frac{d^2}{dt^2} (\xi(t)) = K \cdot \xi^{-2} \text{ where } K \text{ lumps all the } M\text{'s and } Q\text{'s etc.}$$

A numerical solution of the previous equation (for normalized parameter choices) gives:

$$\xi''(t) - 10 \cdot \xi(t)^{-2} = 0 \quad \xi(0) = 1 \quad \xi'(0) = -5$$

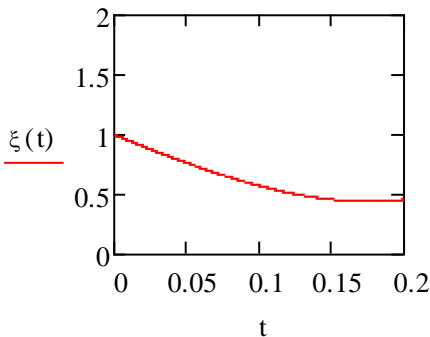

For realistic calculations the constant K , for example a bunch linear dimension in the order of 1 cm, bunch particle density in the 10^{15} m^{-3} range the constant K is in the order of 10^8 and the time scale needs to be scaled down by the same factor (thus in the tens of nanoseconds range) to observe a significant change of the relative distance between the bunches.

3.3.2 Particle-in-Cell Simulations

Detailed simulations of the bunch momentum exchange process have been performed with the particle-in-cell simulation code XOOPIC [XOOPIC]. The simulations done so far have been limited to the electrostatic model, as the interaction between bunches is predominantly electrostatic. The effect of a solenoidal field has been also simulated to observe the bunch radial confinement. The model considers a cylindrical geometry (r-z coordinates) thus ignoring azimuthal asymmetries.

A basic test example is shown in Figure 3.3.2-1 where the expansion of an α -particle bunch is followed on the time scale determined by its space charge.



Figure 3.3.2-1 – PIC simulation of a traveling α -particle bunch in cylindrical geometry.

The simulations have been focused on the analysis of the worst case scenario, where no magnetic field confinement is being provided, to study the free evolution of bunches under the effect of their space charge.

The most effective interaction between bunches is obtained when the collective effect of the bunch charge on the other bunch dominates the internal repulsive dynamics. In order to enhance this effect, the bunches have been shaped as thin charged layers drifting towards each other. In the simulation the target, heavier bunch is initially at rest and the fast, light bunch is approaching (Figure 3.3.2-2).

The target bunch has a density of $5 \cdot 10^{17} \text{ m}^{-3}$ while for the fast bunch the density is 10^{15} m^{-3} and the speed is $3 \cdot 10^6 \text{ m/s}$ (in the negative z-direction). The dimensions are in meters.

The simulations show the repulsive effect in the frame of reference of the initial position of the target bunch. Extrapolation to realistic configuration can be done by adding a bias drift velocity (Figures 3.3.2-3 and 3.3.2-4).

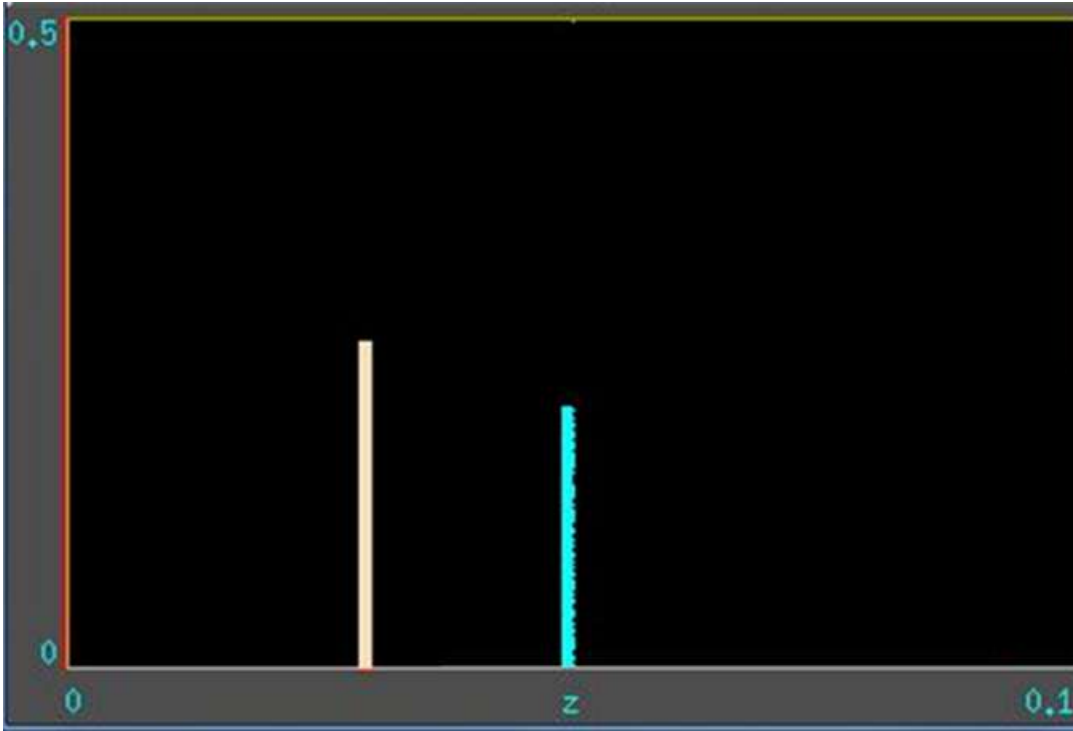

Figure 3.3.2-2 – Initial condition for the bunch interaction simulation: the heavy bunch (white) is at rest while the light bunch (blue) is approaching.

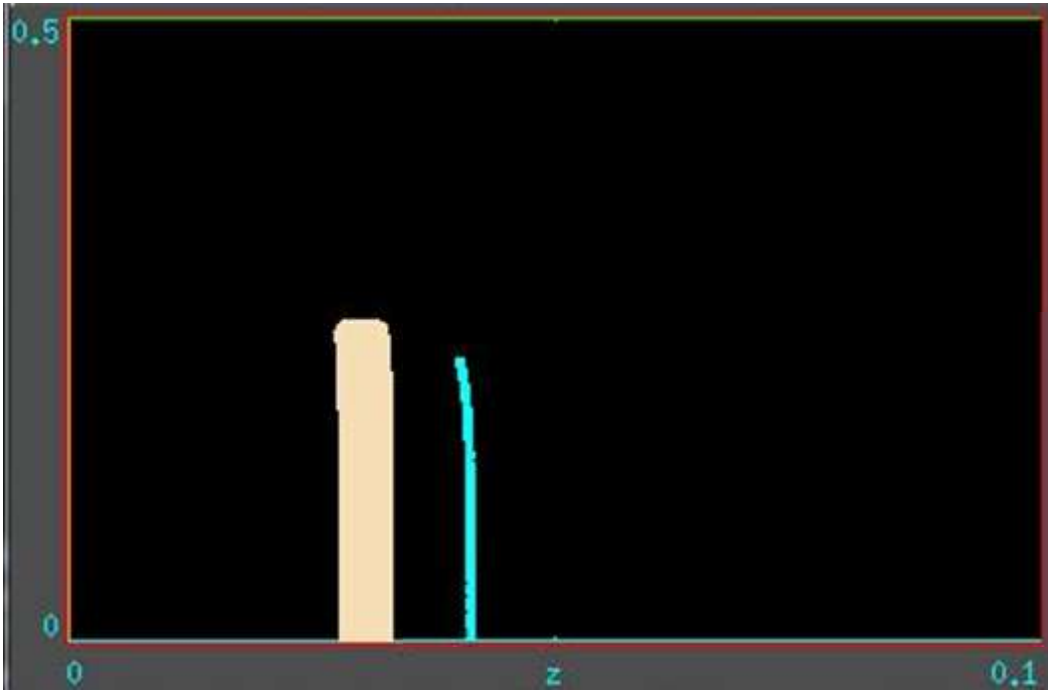

Figure 3.3.2-3 –Time evolution of the previous initial scenario: the fast bunch is close to the minimum approach condition and is reversing its velocity in this frame of reference.

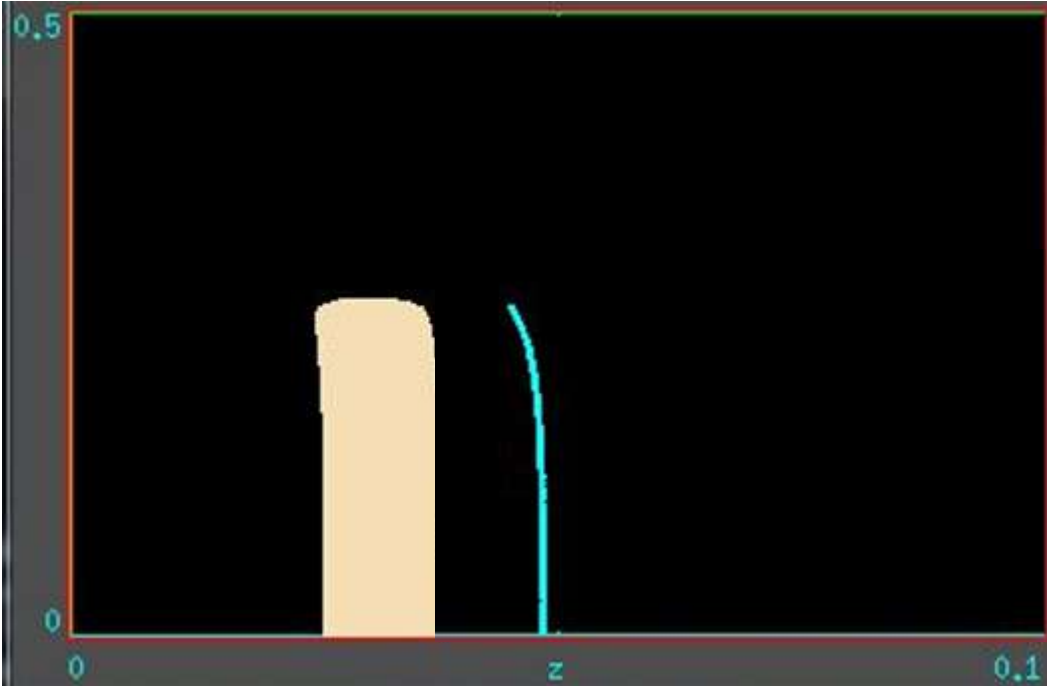

Figure 3.3.2-4 –Further evolution in time of the bunch interaction: the fast bunch has reversed its velocity. The radial expansion is also now noticeable (there is no confining magnetic field). The axial (z-) expansion is more pronounced for the slow bunch as it has higher density.

3.4 Direct Energy Conversion of Fusion Product Energy into Electrical Energy

3.4.1 The TWDEC

An important component of the overall architecture is the system for direct energy conversion (DEC) of the beam energy into electricity. In this concept the energy conversion is carried on only partially, most of the energy of the fusion products is to be delivered to the beam conditioning system to enhance the thrust.

The DEC system that is being considered is the Travelling Wave Direct Energy Converter (TWDEC) [Momota, 1992]: the TWDEC has here the dual function of generating some electricity and of inducing the beam bunching required by the thrust enhancement process.

The TWDEC has been studied in some detail for the purpose of integrating it in the overall simulation model. In this context some new features have been considered for the TWDEC design to allow for higher density beams and hollow, grid-less electrodes.

The motivation for the study of a TWDEC device at high beam density is related to the limits presented by the low-density, space charge limited, ion beams, as they would be able to support only a low power density direct energy conversion.

For the perspective of utilizing the TWDEC concept with a large fusion power reactor, a low-power density TWDEC require a very large structure, resulting in additional engineering constraints for a ground-based reactor and a large mass penalty for a reactor operating on a spaceship.

Another aspect of this investigation is related to the achievable efficiency. The latest composite-cycle steam powered turbine generator can achieve efficiency up to 60%: a robust development program for DEC technologies would be then justified if the perspective of reaching conversion efficiencies near 90% would appear, at least in principle, realistic. A TWDEC process in the high-density regime is then here considered to investigate options that would allow to increase the efficiency.

Conceptually, if the density is high enough (possibly the beam will have to be partially neutralized), collective (plasma like) effects would start to play a role, allowing in principle to develop fast-growing unstable mode that would transfer quickly the beam energy to the EM field, before particle losses would occur in a large number.

3.4.2 Basic Physics of the Energy Conversion in a TWDEC

The ion beam in a TWDEC travels across a modulator section that induces a bunching of the beam followed by a series of grids on which the alternating potentials are induced. As the bunch travels,

capacitive coupling between the beam and the grid conducting structure induces a time-dependent electric potential difference between adjacent grids.

Let C_{bg} be the capacitance between a grid electrode and the closest ion bunch. At any given time a charge Q_b will induce a potential $V = Q_b/C_{bg}$. The capacitance is obviously time-dependent, as the bunch travels, first approaching, then moving away from the electrode.

An estimate of the capacitance C_{bg} can be made to outline the role of the beam (bunch) density. Let the ion bunch be approximated by a spherical charge distribution of radius R_b . The grid electrode will be first approximated by a conducting plane with a circular hole, corresponding to the cross section of the beam (Figure 3.4.2-1).

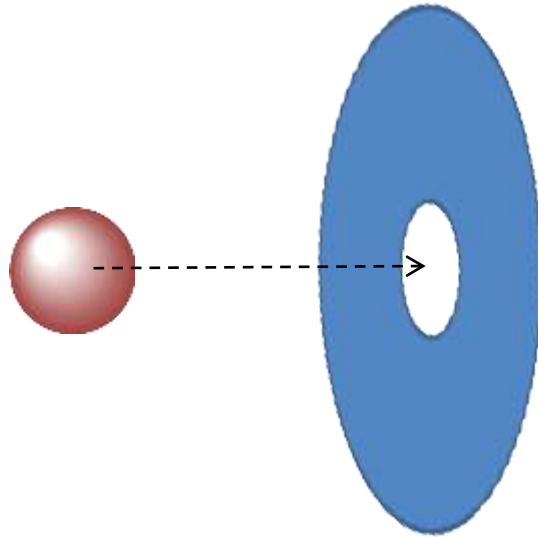

Figure 3.4.2-1– Ion bunch approaching electrode

The capacitance of a sphere of radius R_b near a large flat conductor at distance d is considered, neglecting for now the effect of the hole.

For $d \gg R_b$ the capacitance is approximated by [Kaiser, 2005]

$$C_{sp} \approx \frac{4\pi\epsilon_0}{\frac{1}{R_b} - \frac{1}{2d}} \quad (0.1)$$

The potential induced by the ion bunch will be then

$$V_b = \frac{Q_b}{C_{sp}} \approx \frac{Q_b}{4\pi\epsilon_0} \cdot \left(\frac{1}{R_b} - \frac{1}{2d} \right) \approx \frac{Q_b}{4\pi\epsilon_0} \frac{1}{R_b}, \quad (0.2)$$

That is, the electrostatic coupling between the bunch and the electrode increases with the charge and decreases with the distance.

3.4.3 Modeling TWDEC Bunch-Electrode Coupling

A conceptual model for the capacitive coupling in the TWDEC has been devised and verified in some preliminary PIC simulations. The model considers the ion beam in a TWDEC travelling across a modulator section that induces a bunching of the beam followed by a series of grids on which the alternating potentials are induced.

As the bunch travels, capacitive coupling between the beam and the grid conducting structure induces a time-dependent electric potential difference between adjacent grids.

Let C_{bg} be the capacitance between a grid electrode and the closest ion bunch. At any given time a charge Q_b will induce a potential $V = Q_b/C_{bg}$. The capacitance is obviously time-dependent, as the bunch travels, first approaching, then moving away from the electrode. In TWDEC electrostatic induction one must consider the capacitances between a traveling bunch and the two adjacent electrodes, as in Figure 3.4.3-1.

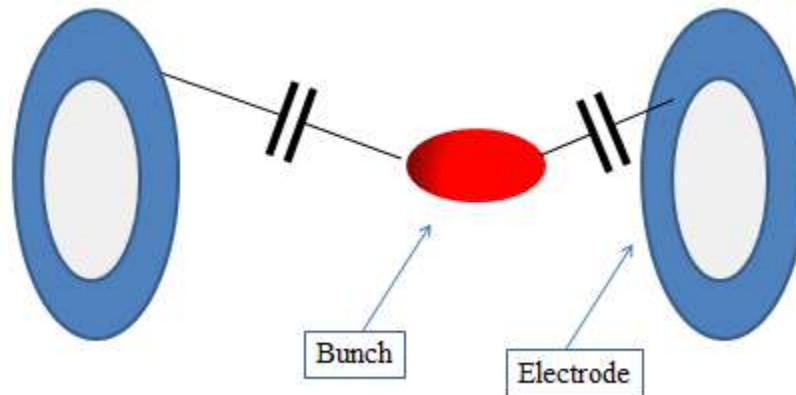

Figure 3.4.3-1 – Schematic of the capacitive coupling of the bunch in between two TWDEC electrodes

As the bunch travels, the highest potential difference between two adjacent electrodes as the bunch passes through one of them while zero potential difference when the bunch is half-way in between the two electrodes (Figure 3.4.3-2).

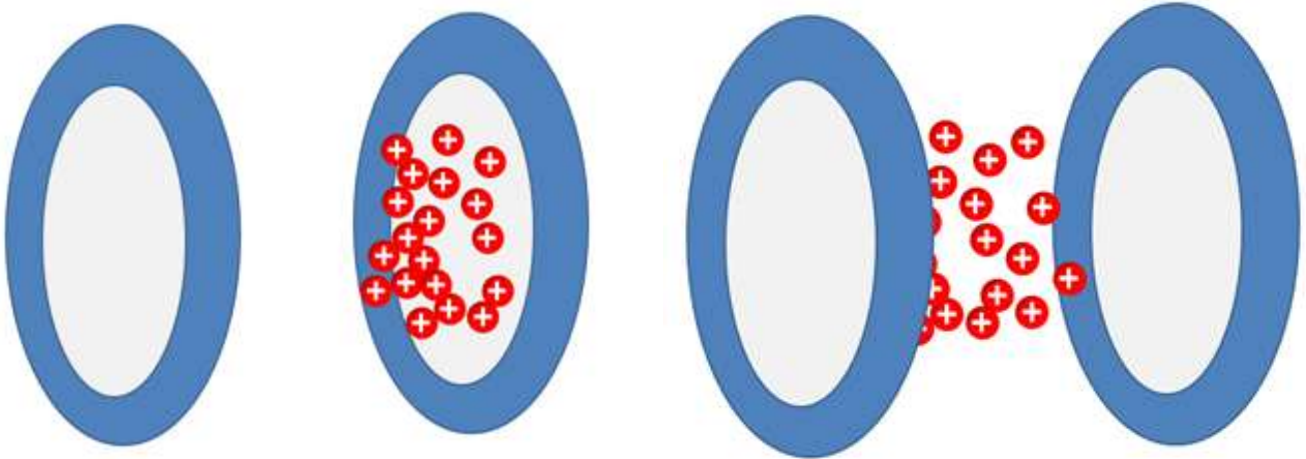

Figure 3.4.3-2 –Capacitive coupling of the bunch in between two TWDEC electrodes: conditions for maximum and minimum value of the induced potential difference

For the case where the bunch is crossing right through the electrode a different model needs to be considered.

This model relates to the condition where the highest potential difference between two adjacent electrodes is reached as the bunch passes through one of them: the model is that of coaxial cylinders (coax cable) with length much greater than the radius (Figure 3.4.3-3).



Figure 3.4.3-3 –Capacitive coupling of the bunch passing through a long TWDEC electrode: coaxial cable approximation

The model approximates the capacitance between the bunch and the passing-through electrode by the capacitance of two concentric cylinders (coax cable):

$$C_{max} = \frac{2 \cdot \pi \cdot \epsilon_0 \cdot l_{th}}{\ln\left(\frac{r_{ele}}{r_b}\right)}$$

where l_{th} is the axial length of the cylindrical electrode, r_{ele} is its radius, $l_{th} \ll r_{ele}$ and r_b is the bunch radius.

For example, with $l_{th}=10 \text{ cm}$, $r_{ele}=1 \text{ cm}$ and $r_b=0.9 \text{ cm}$ it is found $C_{max}=53 \text{ pF}$.

The induced potential on the electrode for a given charged bunch of charge Q_b will be $V_{ele}=Q_b/C_{max}$ α -particle bunch density 10^{15} m^{-3} , bunch length $l_{th}=10 \text{ cm}$, $2.54 \cdot 10^{10}$ particles per bunch and $Q_b = 8.1 \cdot 10^9 \text{ C}$.

The induced potential on the electrode for a given bunch of charge Q_b will be $V_{ele}=Q_b/C_{max}=154 \text{ V}$.

3.5 Supporting Laboratory Experiments

An experimental plan on key physics issues has been carried on at University of Illinois Urbana-Champaign (UIUC) Fusion Studies Laboratory. The goals of these experiments are to provide the ability of testing key physics aspects of the beam conditioning for the proposed spacecraft architecture. These aspects include:

- Testing of the TWDEC at higher density
- Validating the direct energy-to-thrust conversion via beam bunches interaction
- Utilization of the Helicon Injected Inertial Plasma Electrostatic Rocket (HIIPER) plasma jet for the generation of a high-density ion “bunched” beam
- Realistic, initial experiment on the implementation of the TWDEC concept at high densities by means of a TWDEC stage directly connected to a IEC plasma device

3.5.1 Inertial Electrostatic Confinement Plasma Device

A basic IEC device (Figures 3.5.1-1 and 3.5.1-2) has been utilized for generating a plasma jet (Figure 3.5.1-3) and collecting preliminary diagnostics on plasma parameters with a Faraday cup.



Figure 3.5.1-1. IEC Device at UIUC: 50 kV, 50 mA, 1 kW max. 44” diameter spherical stainless steel IEC chamber. Base vacuum $<10^{-6}$ Torr.

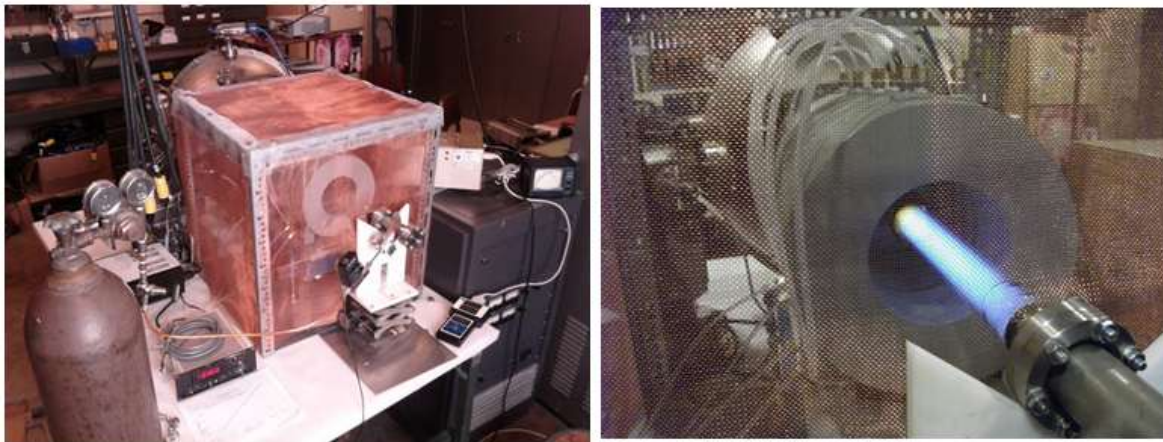

Figure 3.5.1-2. IEC Device at UIUC: plasma from a 300 W Helicon source

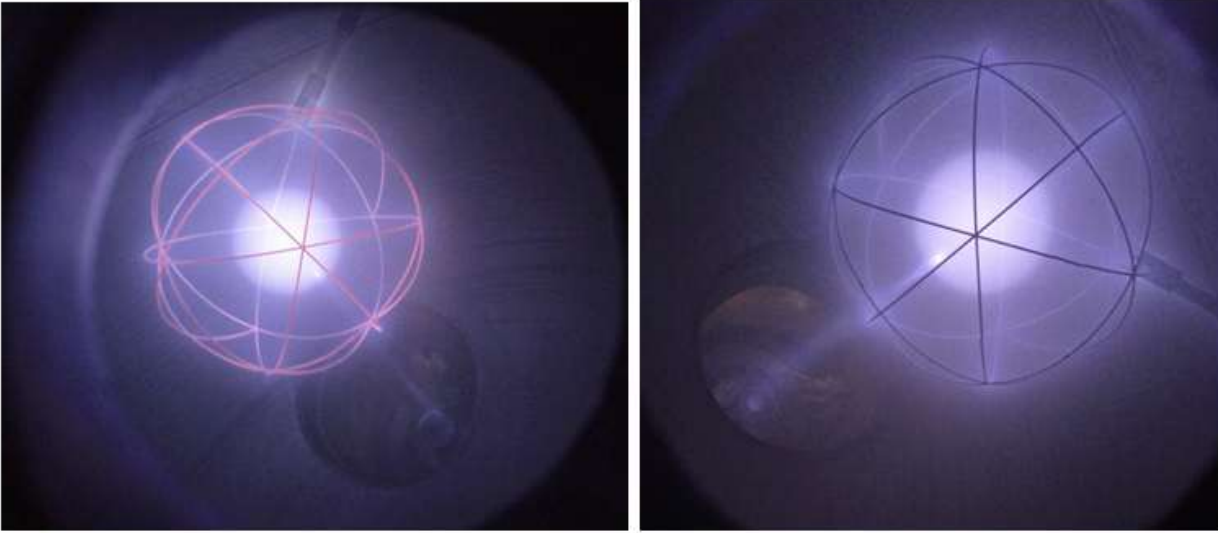

Figure 3.5.1-3. IEC Device at UIUC: IEC plasma with energized grid and formation of plasma jet

3.5.2 Diagnostic Results from the IEC Plasma

A force sensor has been tested to measure the dynamics effect of the plasma jet. The sensor measures the total force exerted by the plasma jet by means of a configuration of 4 temperature-compensated piezoelectric sensors (Micron Instruments Inc.) as illustrated in Figure 3.5.2-1.

The sensor calibration was performed by measuring $\text{mV}/\mu\text{m}$ deflection and compared with COMSOL simulation of $\text{N}/\mu\text{m}$ deflection to obtain mV/N calibration curve. The noise floor was estimated at $\sim 10 \mu\text{N}$.

A Faraday cup was installed with the dual capability of measuring currents and heat flux due to the impinging jet (Figure 3.5.2-2). A Platinum Resistance Temperature Detector (RTD) gives heating rate measurement allowing calculation of power delivered in jet. Current measurements can be used along with the RTD measurements to infer the density of the jet.

The slope of the temperature data for each IEC power level can be used to determine the heat flux (energy flux) into the Faraday cup. The slope of the temperature data for each IEC power level can be used to determine the heat flux (energy flux) into the Faraday cup (Figure 3.5.2-3).

Determining the value of the specific heat of the cup is non-trivial due to geometry, position of the sensor, and use of three different materials (SS, Al, Al_2O_3). A Comsol simulation model was used to provide a calibration curve of heat input vs. dT/dt for the RTD.

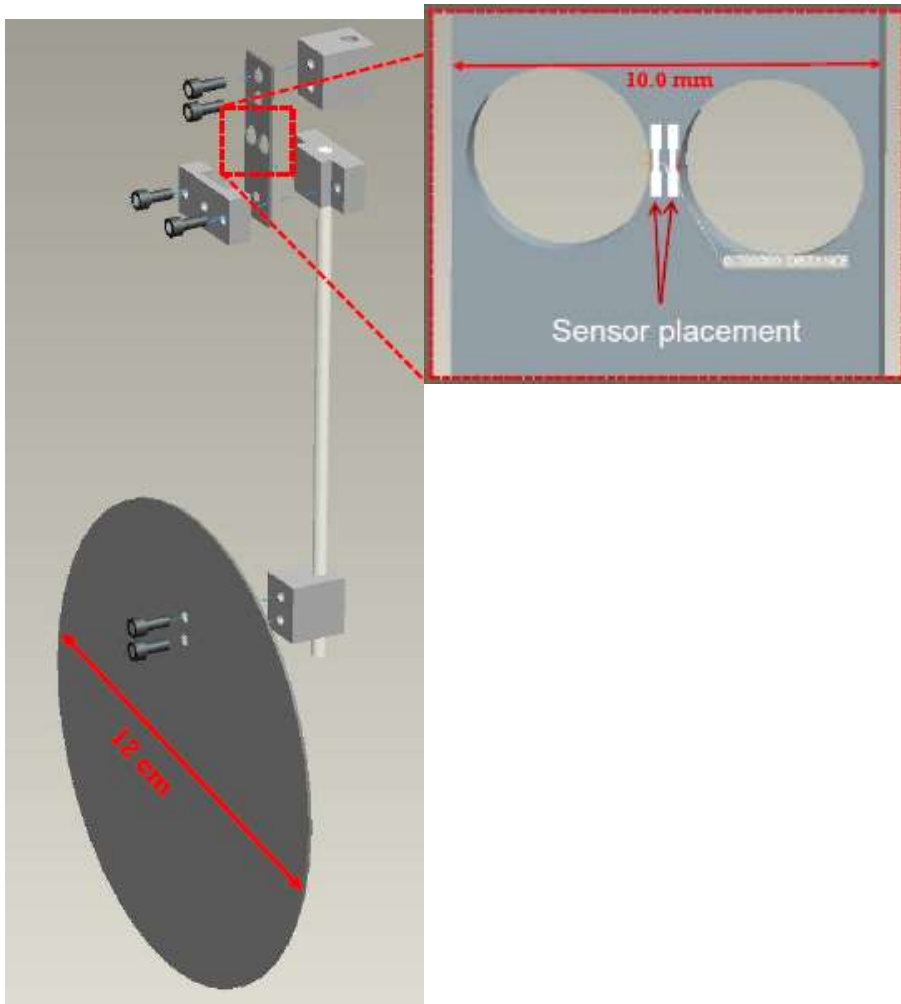

Figure 3.5.2-1. Force sensor to diagnose the plasma jet dynamics



Figure 3.5.2-2. Faraday cup

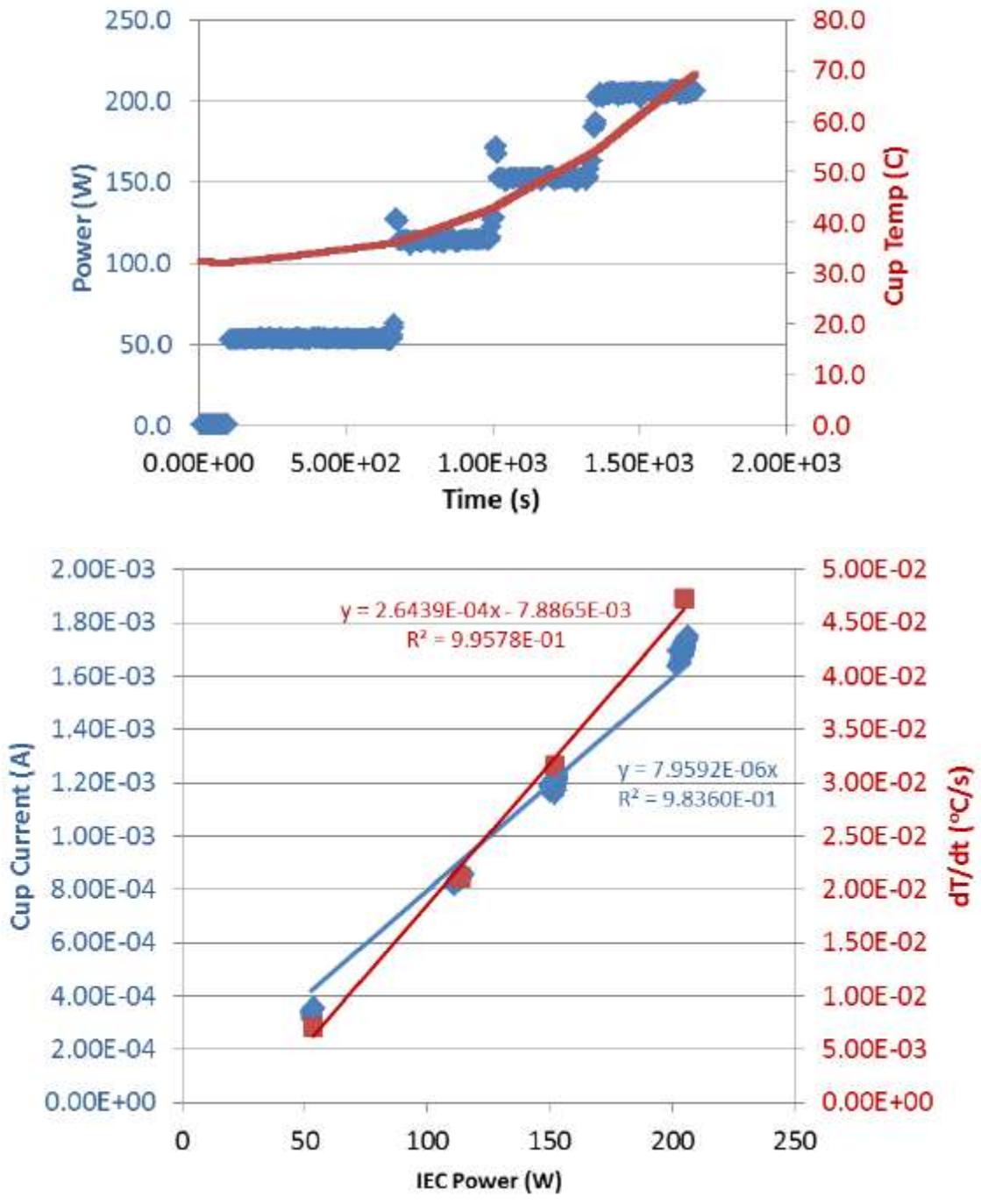

Figure 3.5.2-3 Thermal data from the Faraday cup

4. Recommended Near-Term Research Directions

4.1. Identification of Critical Paths to Feasibility Demonstration

The present research results are pointing towards a development path leading to a higher TRL. The new physics elements need to be tested with a well integrated modeling and experimental effort.

4.1.1 Synergistic Approach

The specific implementation of a future research plan is here outlined in reference to the feasibility demonstration. A definite experimental proof of the proposed concept poses an extremely high challenge and is beyond the resources that the NIAC program can provide. However, this proposed effort is relying on a synergy of theory developments, computer modeling, and selected experimental investigations to study the technical feasibility of key issues for the realization of proposed aneutronic fusion spacecraft architecture concept.

4.1.2 Critical Research Directions

From the analysis conducted in Phase I, there are four critical elements that have been identified for further research on the proposed concept, prioritized as follows:

- Fast bunch-to-slow bunch “pusher”
- Charge neutralization/ejection
- High-efficiency, high-density Travelling Wave Direct Energy Convertor (TWDEC)
- Fusion product collector/collimator

A fifth key element is the feasibility of a fission hybrid interim concept, which is important as long as an actual aneutronic fusion core is not available.

4.2 Bunch-to-Bunch “Pusher”

4.2.1 Simulation Tools

The basic simulation research tool is the PIC simulation, taking advantage of the experience acquired in Phase I. The proven, already acquired tools like OOPIC and COMSOL (with self-consistent particle interaction package) can be utilized. A more powerful PIC simulation tool like VORPAL is recommended.

4.2.2 Production Runs

Increasingly realistic production runs shall be considered to explore the parameter space, seeking the most effective conditions in terms of efficiency of the energy transfer from the fast ion bunches to the slow, massive ones.

Variation of the bunch density profile and magnetic and an electrodynamic (traveling potential well) approach to control and maintain the desired configuration are to be explored.

COMSOL simulations will allow validating the PIC production runs and begin to study three dimensional configurations.

4.2.3 Experiments

Experimental plans shall be devised to utilize and leverage available experimental facilities within the research team institutions to diagnose the time-dependent profile of the ion bunches under the effect of the mutually repulsive, long-range electrostatic forces. Investigation of the generation of high-density target ion bunches can be planned within the resources utilized in this study and leveraging hardware available or in current acquisition process both at UIUC and JSC.

4.2.4 Investigation of an Old Concept

Investigation on the condition for implementing an effective “magnetic piston” effect for the bunch “pusher” shall be first attempted computationally.

An experimental plan shall be devised consisting of a basic test on bunch injection and trapping in a constant magnetic field. The experiment will be equipped with sensitive diagnostics for recording magnetic fluctuations. The results will be correlated with the modeling results with equivalent parameters.

4.3 Electron Neutralization/Ejection

4.3.1 System-Level Analysis

A system-level design of the overall neutralization scheme will be developed with the COMSOL package. PIC simulation of neutralizations paths will follow with focus on smaller scale dynamics.

4.3.2 Experiments

Experiments on electron/ion separation shall be designed both in reference to slow ion bunch production and fast ion bunched beams at high density and performed in correlation or as part of other experimental plans being developed under this proposal.

4.3.3 Partial Neutralization

The possibility of limiting the natural tendency of the ion bunches to expand and thermalize by considering a partial neutralization of the bunch space charge can be investigated with dedicated simulation tests.

As the particle bunches travel very fast and the length of the thruster has to be reasonably limited, even a small reduction of the expansion rate could have an important impact on the effectiveness of the energy transfer. The key assumption behind this investigation is that the bunch

repulsion is mainly a surface effect, while the expansion is a volume effect. A partially neutralizing “core” may be able to decrease the expansion rate without affecting significantly the repulsion field.

4.3.4 Nanoparticle Jet

A novel concept involving a charge-neutralizing flow carried by a jet of negatively charged nanoparticles can be investigated from a complex plasma theory approach and with both PIC and COMSOL modeling.

Efficiency issues related to the production of the nanoparticle jet will be addressed by leveraging existing contacts with other experimental groups in the field.

4.4 High-Efficiency, High-Density TWDEC

4.4.1 TWDEC Simulation

PIC simulations from Phase I need to be extended to a multistage configuration. The effect of a particle energy spread and possible countermeasures based on the “fan” type electrode architecture [Yasaka, 2009] shall be investigated. The analysis of the effectiveness of hollow and extended (profiled, cylindrical versus flat) electrode design shall be also addressed in the presence of high-density bunches.

4.4.2 Experiments

With the already acquired hardware, an effort is in progress for developing a TWDEC test article at JSC.

Under this proposed effort, a vetted experimental measurement program on TWDEC technology that is relevant to the proposed concept are being considered.

Should further resources become available for the TWDEC JSC experimental activity, the current plan is to utilize that resource to push the state-of-the-art knowledge related to high-density TWDEC conversion, bunched beam production, and velocity space collimation to produce the most favorable conditions for the fast-to-slow ion bunch energy transfer.

4.5 Fusion Product Collector/Collimator

Particle collector modeling via simulation of particle trajectories can be developed with the COMSOL package for studying the trapping, redirection, and collimation of MeV energy particles from an isotropic spherical source (representing the fusion core).

The simulation needs to be extended to describe the electron dynamics. This process is essential in designing the “feeder” of the TWDEC from the fusion core.

4.6 Fission Hybrid Interim Concept

A system level analysis that extends the Phase I system level study shall be conducted including compact fission reactor performance for state-of-the-art and near-term foreseeable designs. This particular investigation is aimed at providing a high-level assessment of the “ α ” obtainable for different scenarios in which fission power provides all or part of the energy required for running the aneutronic fusion core and producing the ion flow.

Estimates of the performance of these fission-fusion hybrid scenarios will allow a direct comparison with more conventional concepts of fission energy to power a nuclear thermal thruster or thermal plasma rocket, in which case the overall performance shall take into account the presence of the magnetic nozzle.

Conclusions

A novel fusion propulsion architecture has been investigated to enable the proper conditioning of the fusion product flow in order to meet optimal propulsion requirements with minimal energy loss.

In order to achieve game-changing mission capability a stand-alone aneutronic fusion reactor is not sufficient, nor is it enough to develop only an efficient advanced (electric) thruster. A deep integration of spacecraft power and propulsion management is required.

Thus, to reach this goal, the proposed research is investigating the feasibility of a system that allows direct conversion of the products of aneutronic fusion reactions into useful thrust.

The proposed architecture approximates an ideal propulsion scheme, wherein a high-density primary energy source directly ejects mass (the propellant) in the direction of thrust. This concept is based on aneutronic nuclear fusion as the high-density primary energy source. Some energy is then extracted from the fusion reaction products via direct energy conversion to recirculate power as required for the operation of the fusion core. The remaining flow of reaction products is ejected into space for producing the required propulsive thrust. At this final stage, the ejected beam will have been conditioned to achieve the actual values of thrust and specific impulse that are required for a given phase of the mission profile.

This concept is realized essentially in a three-stage process, with most of the truly innovative aspect contained in the third stage:

- (i) The flow of charged particles originating from the fusion reactions is collected and channeled (magnetically) into a unidirectional beam.
- (ii) A direct energy-conversion process (based on cusp and traveling-wave direct energy converters [15]) re-circulates electric energy into the fusion core, as required for its regime operation. The “leftover” beam then exiting the converter is in the form of fast “bunches,” facilitating further conditioning and utilization.
- (iii) The “fast bunch beam” is injected into a solenoidal magnetic field, confined on a large spiral trajectory. This increases somewhat the beam’s average density while lowering its kinetic energy in the direction of thrust. In order to achieve the lower specific impulse and the higher thrust needed to meet target design parameters, it is required to transfer to the energy of the fast bunches to slower, higher-density ion bunches being injected as targets downstream. The process relies on the mutual electrostatic repulsion of particle bunches enhanced by a “magnetic piston” effect caused by the current induced by the fast-bunch trajectory.

The object of this study is a new advanced space propulsion architecture that can significantly change the paradigm of both human and robotic space exploration. A new propulsion paradigm that enables faster and extended space travel is arguably the technology development that could have the largest impact on the overall scope of the NASA mission, essentially enabling the most defining and important aspect of the agency’s role.

References

- [Burton, 2003] R. Burton, *et al.*, Space Technology and Applications International Forum (STAIF-2003) APS, Conf. Proc. 654, 553, (2003).
- [Bussard, 1991] R. Bussard, Fusion Technology, 19 (2), 273 (1991)
- [Glasstone, 1975] S. Glasstone, R. H. Lovberg, "Controlled Thermonuclear Reactions," Krieger Pu. (1975)
- [Jarboe, 2005] T. R. Jarboe *et al.*, J. Propulsion and Power, 21 (2), 218 (2005)
- [Kaiser, 2005] K. L. Kaiser: "*Electromagnetic Compatibility Handbook*", CRC Press (2005)
- [Kunkel, 1966] W.B. Kunkel, "Plasma Physics in Theory and Applications", Wiley (1966)
- [Miley, 1999] G. H. Miley *et al.*, AIAA-99-2140 (1999)
- [Miley, 2004] G. H. Miley *et al.*, Space Technology and Applications International Forum (STAIF-2004) APS, Conf. Proc. 699, 399, (2004).
- [Moeckel, 1972] W. E. Moeckel, J. Spacecraft, 9 (12), 863 (1972)
- [Momota, 1992] Fusion Technology, 21,2307 (1992)
- [Rostoker, 2002] Rostoker *et al.*, Proc. Symp. Current trends in international fusion research, E. Panarella Ed. p. 79 (2002)
- [Rostoker, 2003] Rostoker *et al.*, J. Fusion Energy, 22 (2), 83 (2003)
- [Tuszewski, 1989] M. Tuszewski, "Field reversed configurations," Nucl. Fusion, 28, 2033–2091 (1988)
- [Williams, 1996] C. H. Williams, NASA Technical Memorandum 107058 (1996)
- [Williams, 2001] C. H. Williams *et al.*, AIAA 2001-3805 (2001)
- [XOOPIC] <http://ptsg.eecs.berkeley.edu/pub/codes/xoopic/>
- [Yasaka, 2009] Y. Yasaka *et al.*, Nucl. Fus., 49, 075009 (2009)

Appendix

As discussed in [Moeckel, 1972] under a constant acceleration assumption, the " Δv " required for a rendez-vous trip of length R_R and duration T is found from

$$R_R = \Delta v \cdot \frac{T}{3}$$

The maximum specific impulse required is then

$$I_{spMax} = \frac{\Delta v}{g} = \frac{3R_R}{g \cdot T}$$

For a Mars trip with $R_R \approx 0.5$ A.U. By using the previous example and converting to SI units

$$\Delta v := \frac{3 \cdot R_R \cdot \text{AU}}{T_{\text{Mars}} \cdot \text{yr}} = 5.229 \times 10^4 \frac{\text{m}}{\text{s}}$$

$$I_{spMax} := \frac{3 \cdot R_R \cdot \text{AU}}{g \cdot T_{\text{Mars}} \cdot \text{yr}} = 5.332 \times 10^3 \text{ s}$$

The constant acceleration is simply $a_0 = 3 \Delta v / T$ and the corresponding required initial thrust (at zero velocity) is $F_T = m_i a_0$. The thrust as function of time will vary during the trip and is found by replacing the actual mass at any given instant in the previous expression.