

THE UNIVERSITY OF WARWICK

Original citation:

Liu, Teng, Gao, Weiguo, Tian, Yanling, Zhang, Hongjie, Chang, Wenfen, Mao, Ken and Zhang, Dawei. (2014) A differentiated multi-loops bath recirculation system for precision machine tools. Applied Thermal Engineering, 76 . pp. 54-63.

Permanent WRAP url:

<http://wrap.warwick.ac.uk/76431>

Copyright and reuse:

The Warwick Research Archive Portal (WRAP) makes this work of researchers of the University of Warwick available open access under the following conditions. Copyright © and all moral rights to the version of the paper presented here belong to the individual author(s) and/or other copyright owners. To the extent reasonable and practicable the material made available in WRAP has been checked for eligibility before being made available.

Copies of full items can be used for personal research or study, educational, or not-for-profit purposes without prior permission or charge. Provided that the authors, title and full bibliographic details are credited, a hyperlink and/or URL is given for the original metadata page and the content is not changed in any way.

Publisher statement:

© 2014 Elsevier, Licensed under the Creative Commons Attribution-NonCommercial-NoDerivatives 4.0 International <http://creativecommons.org/licenses/by-nc-nd/4.0/>

A note on versions:

The version presented here may differ from the published version or, version of record, if you wish to cite this item you are advised to consult the publisher's version. Please see the 'permanent WRAP url' above for details on accessing the published version and note that access may require a subscription.

For more information, please contact the WRAP Team at: publications@warwick.ac.uk

warwick**publications**wrap

highlight your research

<http://wrap.warwick.ac.uk/>

A Differentiated Multi-loops Bath Recirculation System for Precision Machine Tools

Teng Liu¹, Weiguo Gao^{1,2*}, Yanling Tian^{1,2}, Hongjie Zhang^{1,3}, Wenfen Chang^{1,4}, Ken Mao², and Dawei Zhang¹

¹ *Key Laboratory of Mechanism Theory and Equipment Design of Ministry of Education, Tianjin University, Tianjin 300072, China*

² *School of Engineering, University of Warwick, Coventry, CV4 7AL, UK*

³ *School of Mechanical Engineering, Tianjin Polytechnic University, Tianjin 300387, China*

⁴ *Beijing Precision Machinery & Engineering Research Co., Ltd., Beijing 101312, China*

Abstract: Traditional bath recirculation cooler for precision machine tools always has the uniform and open-loop cooling strategy onto different heat generating parts. This causes redundant generated heat being transferred into the machine structure, and results in unsatisfactory thermal errors of precision machine tools. For the solution of this problem, this paper presents the differentiated multi-loops bath recirculation system. The developed system can accomplish differentiated and close-loop cooling strategies onto machine heat generating parts during its operation. Specially, in order to illustrate the advantages of this system, constant supply cooling powers strategy is presented with its applications onto a certain type of built-in motorized spindle. Consequently, advantages of the proposed strategy based on the differentiated multi-loops bath recirculation system are verified experimentally in the environment within consistent temperature ($T_R=20\pm 0.3^\circ\text{C}$). Compared with room temperature tracing strategy based on the traditional bath recirculation cooler, the constant supply cooling powers strategy is verified to be advantageous in spindle temperature stabilization and thermal errors decrease.

Keywords: Differentiated multi-loops bath recirculation system, Constant supply cooling powers strategy, Close-loop, Thermal errors, Built-in motorized spindle

*E-mail address of the corresponding author: gaowg@tju.edu.cn

1 Introduction

2 The internal heat, generated from the running machine tool, gives rise to its unexpected
3 temperature fluctuation, and consequently results in the machine thermal errors. Generally, in
4 precision machining, thermal errors contribute to about 70% of machine comprehensive errors
5 ^[1,2]. In other words, the thermal factor plays a major role to disturb the machine accuracy, and
6 should be mainly reduced to improve the machine precision.

7 The bath recirculation cooling, being a conventional and effective method to handle the
8 internal generated heat of machine, has been applied onto kinds of precision machine tools.
9 When the precision machine tool is in operation, the recirculation coolants are applied directly
10 onto heat generating parts to take away the heat ^[3]. By this method, bath recirculation cooling
11 can effectively stabilize the machine temperature field and then reduce its thermal errors.

12 However, with the rapid evolution of precision machine tools, deficiencies are emerging in
13 the applications of traditional bath recirculation cooling. Generally, different kinds of machine
14 heat generating parts (motor, bearings. etc) have different heat power scales. But in traditional
15 bath recirculation cooling applications, the flowing coolant from bath recirculation cooler is
16 always guided by flow divider in order to cool different machine heat generating parts. This
17 cooling behavior results in the uniform supply temperature onto the different heat generating
18 parts, and differentiated supply temperature controls onto heat generating parts of machine tool
19 are hardly accomplished. Besides, traditional bath recirculation coolers always have open-loop
20 cooling strategies onto precision machine tools. These strategies cannot accomplish real-time
21 responses of coolant supply temperature onto machine time-varying thermal behaviors in its
22 operation. All these above result in that: although internal generated heat of precision machine
23 tool can be dissipated by using the traditional bath recirculation cooler, there is the redundant
24 generated heat being transferred into machine structure, and causing unsatisfactory thermal
25 errors ^[4,5]. Generally, the scales of these thermal errors are too large to be ignored for precision
26 machine tools.

27 In order to resolve this problem, the differentiated multi-loops bath recirculation system is
28 developed. This system can accomplish the independent and differentiated supply temperature
29 controls onto different heat generating parts in machine operation. Furthermore, the constant
30 supply cooling powers strategy is developed for illustrating the advantages of this system. This
31 strategy is accomplished experimentally onto a certain type of built-in motorized spindle (Room
32 temperature = $20\pm 0.3^{\circ}\text{C}$). The paper structure is arranged as follows: Section 2 provides the
33 structure and working principle of differentiated multi-loops bath recirculation system. Based

1 on this system, Section 3 discusses the theory and accomplishment of constant supply cooling
2 powers strategy, based on the real-time temperature feedback of spindle coolant outlets. Finally,
3 Section 4 illustrates the effectiveness verifications of this strategy in the spindle temperature
4 stabilization and the thermal errors decrease, by the method of contrasting experiments. Section
5 5 draws the conclusions and prospects of the study.

6 **2 Differentiated Multi-loops Bath Recirculation System**

7 In order to accomplish the independent and differentiated supply temperature controls onto
8 heat generating parts of precision machine tool, the differentiated multi-loops bath recirculation
9 system is developed. This section introduces the structure and working principle of this system.
10 That is the device preparation for the constant supply cooling powers strategy in Section 3.

11 **2.1 Working Principle of Differentiated Multi-loops Bath Recirculation System**

12 The differentiated multi-loops bath recirculation system is developed based on 2 recirculation
13 coolers having the same supply pressure, several independent coolant blenders and control units.
14 As illustrated in Fig.1, 2 recirculation coolers are in 2 recirculation trunks respectively, and can
15 supply recirculation coolants at high and low temperatures; every recirculation branch, being
16 equipped with an independent coolant blender, is connected with the coolant channel via
17 machine heat generating parts. First of all, recirculation coolants, from 2 recirculation coolers,
18 are directed from 2 trunks into independent coolant blenders by input electric valve groups ^[6].
19 Then the supply blended coolants (according to supply temperature and flow rate instructions
20 from control units) in branches are flowing into machine channels to cool the heat generating
21 parts. Finally, all the recirculation coolants in branches return, through output electric valve
22 groups, to 2 recirculation coolers in trunks. The accomplishment principles of differentiated
23 supply temperatures and volume flow rates in branches are as follows.

24 **2.2 Accomplishment Method of Differentiated Supply Temperatures in Branches**

25 In the differentiated multi-loops bath recirculation system, every recirculation branch is
26 connected with 2 trunks by the input and output electric valve group, and every group includes
27 2 electric valves to direct recirculation coolant from or to 2 trunks respectively. The detailed
28 design is described in Fig.2: First of all, the input electric valve from trunk 1(2) has the
29 self-lock with the output electric valve to trunk 1(2). This can ensure that the input and output
30 electric valves connected with the same trunk have the same open range, thus to ensure a

1 constant volume flow rate. Besides, inside any input and output electric valve group, any one
2 electric valve has the interlock with the other. That means, in any electric valve group, the open
3 range of one valve is always opposite to the open range of the other. This can make the 2
4 electric valves in the same group reach any open range ratio, to make the independent coolant
5 blender provide approximately this branch with any objective supply temperature; certainly the
6 current branch supply temperature must be higher than the low trunk supply temperature, and
7 lower than the high one.

8 In each branch, the control unit receives the instructions (objective supply temperature). Then
9 it controls the blending ratio, inside the independent coolant blender, of trunk recirculation
10 coolant at high and low supply temperature, to approach and accomplish the objective branch
11 supply temperature, thus to cool the machine heat generating parts. The various blending ratios
12 in branches result in the independent and differentiated supply temperature controls onto heat
13 generating parts of precision machine tool.

14 **2.3 Accomplishment Method of Differentiated Supply Volume Flow Rates in Branches**

15 In every branch of the differentiated multi-loops bath recirculation system, the independent
16 coolant blender is equipped with a centrifugal pump, to control the supply pressure into this
17 branch. As shown in Fig.3, when the control unit receives the instructions (objective supply
18 pressure), it will control the centrifugal pump to modify the branch supply pressure. Because
19 the branch supply volume flow rate can increase only if its supply pressure increases, the
20 modifiable supply pressure can accomplish independent and differentiated supply volume flow
21 rate of recirculation coolant in any branch.

22 **2.4 Signal Instruction Conveying of Control Units**

23 All the control units of independent coolant blenders and bath recirculation coolers are
24 connected with the host computer by the communication unit (USB converted to RS485), which
25 is shown in Fig. 4. The host computer software contains 2 modules: control module and
26 monitoring module (the latter is concerned in Section 4). In control module, the signal
27 instructions of objective supply temperatures and volume flow rates in recirculation trunks and
28 branches can be set. Then the instructions are conveyed to all the control units to perform in
29 recirculation trunks and branches.

30 The control units perform these instructions by PID control mode. As shown in Fig.4, there
31 are digital LED displays to illustrate the objective and current supply temperatures on the

1 controller panels of every bath recirculation cooler and independent coolant blender. The
2 current supply temperature is detected by the temperature sensors inside them. Besides, the
3 current branch volume flow rates and trunk supply pressures can also be observed on the bath
4 recirculation coolers and independent coolant blenders.

5 **3 Constant Supply Cooling Powers Strategy Applied onto Built-in Motorized Spindle**

6 Constant supply cooling powers strategy is the first and typical close-loop cooling strategy
7 based on differentiated multi-loops bath recirculation system. This section discusses the theory
8 and accomplishing method of this developed strategy, with its applications onto a certain type
9 of built-in motorized spindle.

10 **3.1 Internal Heat Generating Parts and Coolants of Built-in Motorized Spindle**

11 Fig. 5 shows the structure of a certain type of built-in motorized spindle. As illustrated in it,
12 its main heat generating parts contains front bearings, back bearing, and the built-in motor
13 (stator and rotor). Meanwhile, 3 helical coolant channels are designed nearby every spindle heat
14 generating part to support recirculation coolants to take away the internal generated heat. In the
15 operation of built-in motorized spindle, some generated heats are absorbed by recirculation
16 coolants, but there is still the residual heat being conveyed via contact surfaces of other spindle
17 parts and causes a fluctuation in the temperature field. This transferred heat triggers the spindle
18 thermal errors.

19 In order to detect the input and output temperatures of spindle coolants, inlets and outlets of
20 coolant channels are located with RTD sensors respectively. That is the preparation for the
21 establishment of differentiated multi-loops bath recirculation platform for the built-in motorized
22 spindle (in Section 3.2).

23 **3.2 Differentiated Multi-loops Bath Recirculation Platform for Built-in Motorized Spindle**

24 Because there are 3 helical coolant channels inside built-in motorized spindle, 3 recirculation
25 branches are adopted in differentiated multi-loops bath recirculation system in this paper. Fig. 6
26 shows the establishment of differentiated multi-loops bath recirculation platform for the built-in
27 motorized spindle. Firstly, 3 spindle coolant channels are connected with 3 independent coolant
28 blenders (3 recirculation branches) to accomplish the differentiated cooling controls onto spindle
29 heat generating parts (front bearings, back bearing, and the built-in motor) respectively. Besides,
30 temperature signals from RTD sensors (located to inlets and outlets of 3 spindle coolant channels)

1 are collected by signal acquisition system, and conveyed to the host computer software of
2 differentiated multi-loops bath recirculation system. Eventually, cooling strategy instructions are
3 triggered by the control module in host computer software, and conveyed to independent coolant
4 blenders and bath recirculation coolers, during the spindle operation.

5 **3.3 Theory and Accomplishment of Constant Supply Cooling Powers Strategy for Built-in** 6 **Motorized Spindle**

7 Based on the differentiated multi-loops bath recirculation platform above, the constant supply
8 cooling powers strategy applied onto built-in motorized spindle is introduced as follows.

9 **3.3.1 Disadvantage of Cooling Strategies based on Traditional Bath Recirculation Cooler**

10 Generally, traditional bath recirculation cooler has 2 open-loop cooling strategies: constant
11 supply temperature strategy and room temperature tracing strategy (coolant supply temperature
12 is always equal to room temperature). Open-loop cooling strategies cannot accomplish real-time
13 adjustments of coolant supply temperature according to machine time-varying thermal
14 behaviors in operation. So if the built-in motorized spindle in Fig.5 is equipped with traditional
15 bath recirculation cooler and running under these 2 cooling strategies, the supply cooling
16 powers of recirculation coolants will generally have time-increasing scales. The reason is as
17 follows: Generally, in the initial period of machine operation, although its internal generated
18 heat is transferred into machine structure, there are always small temperature differences
19 between machine structure and flowing coolants. The reason is that the structural temperature
20 of machine tool is varying so slowly during its operation. According to 2nd law of
21 thermodynamics, these small temperature differences lead to small scales of coolant supply
22 cooling powers. Then these small scales of coolant supply cooling powers result in the fact: In
23 the initial period of machine operation, the major of internal generating heat is always not taken
24 away by recirculation coolants, but transferred into machine structure to cause unsatisfactory
25 thermal deformations. However, with the internal heat accumulation of machine structure, the
26 structural temperature is gradually increasing with time. Temperature differences between
27 machine structure and flowing coolants are growingly large to increase supply cooling powers
28 of coolants, and then thermal deformations increase more slowly or even decrease. Therefore,
29 open-loop strategies based on traditional bath recirculation cooler are unsatisfactory for
30 decreasing the machine thermal errors. The reason is that the thermal deformations in initial
31 operation period usually increase rapidly and mainly contribute to total machine thermal errors.

1 The effective method of decreasing thermal errors is to intensify the coolant supply cooling
2 powers in initial period of machine operation.

3 **3.3.2 Theory of Constant Supply Cooling Powers Strategy**

4 In order to intensify supply cooling powers in initial period of machine operation and reach
5 the time-averaged cooling effect, the constant supply cooling powers strategy is developed by
6 the close-loop controlling method. The accomplishment of this strategy relies on differentiated
7 multi-loops bath recirculation system (in Section 3.2). The theory of this strategy is illustrated
8 with the built-in motorized spindle being an example: Generally, the real-time supply cooling
9 powers in spindle operation onto 3 heat generating parts can be calculated as following:

$$11 \quad H^i = c\rho Q^i \Delta T_i^i, i = 1, 2, 3 \quad (1)$$

12
13 In equation (1), i is number of spindle coolant channel (shown in Fig. 5); H^i is supply cooling
14 power of coolant in i th channel (J/s); c is special heat of coolant (J/ (kg K)); ρ is density of
15 coolant (kg/m³); Q^i is supply volume flow rate of coolant in i th channel (L/min); ΔT^i is coolant
16 temperature difference between outlet and inlet of i th coolant channel (°C). Based on strategies
17 of traditional bath recirculation cooler, the time-increasing H^i is attributed to the time-increasing
18 ΔT^i , for c , ρ and Q^i is consistent with time. Therefore, the constant supply cooling powers can
19 be accomplished only if temperature differences between outlet and inlet of coolant channels
20 can be constant and controllable. Because different spindle heat generating parts have different
21 heat power scales, the required values of constant cooling powers onto them are different. Thus
22 this strategy must be accomplished by differentiated multi-loops bath recirculation system.

23 **3.3.3 Accomplishment Principle of Constant Supply Cooling Powers Strategy onto Built-in** 24 **Motorized Spindle**

25 The constant temperature differences between outlet and inlet of coolant channels in spindle
26 operation must be accomplished by close-loop controlling method: The differentiated multi-loops
27 bath recirculation platform in Section 3.2 brings the possibility of real-time signal detection and
28 the further strategy calculations (in control module of host computer) about the coolant outlet
29 temperatures. So in the operation of built-in motorized spindle, constant temperature differences
30 above can be accomplished by the following function:

31

$$T_{su,t+1}^i = T_{ou,t}^i - \overline{\Delta T}^i, i = 1, 2, 3 \quad (2)$$

In equation (2), $T_{su,t+1}^i$ is supply temperature onto i th coolant channel at $t+1$ moment ($^{\circ}\text{C}$); $T_{ou,t}^i$ is the outlet temperature of i th coolant channel at t moment ($^{\circ}\text{C}$); $\overline{\Delta T}^i$ is objective coolant temperature difference between outlet and inlet of i th coolant channel ($^{\circ}\text{C}$). This is a required parameter that must be given before the operation. According to equation (1), $\overline{\Delta T}^i$ determines the objective scales of constant supply cooling powers onto spindle heat generating parts. In the spindle operation, coolant supply temperatures are continuously accomplished by equation (2), which is based on the time-varying coolant outlet temperatures, thus to ensure the constant supply cooling powers onto spindle heat generating parts.

Generally, the temperature variation of coolant is a slow process. Thus only if the interval of moment t and $t+1$ is short enough, $T_{su,t}^i$ and $T_{ou,t}^i$ are approximately equal to $T_{su,t+1}^i$ and $T_{ou,t+1}^i$ respectively, and coolant temperature differences between outlet and inlet of coolant channels are approximately constant with time. Therefore, supply cooling powers onto spindle heat generating parts can be accomplished approximately to be constant with time.

4 Experiments

This section introduces the experimental verification of the effectiveness and advantage of constant supply cooling powers strategy in Section 3.3. The advantage of the proposed strategy can be verified by contrasting thermal behaviors of the built-in motorized spindle under the constant supply cooling powers strategy and the room temperature tracing strategy respectively in experiments.

4.1 Experimental Setup

The experiments were performed for verifying the advantage of the constant supply cooling powers strategy in Section 3. The schematic of the experimental procedure is illustrated in Fig. 7: In the operation of built-in motorized spindle, the temperatures and thermal errors were measured by RTD sensors and eddy current displacement sensors respectively. The signals obtained from those 2 kinds of sensors were conveyed by signal acquisition system to the host computer software (monitoring module).

Specially, the locations of thermal sensors nearby spindle heat generating parts are illustrated in Fig.8: T_A and T_B are measured to be the temperature of front bearings; T_C - T_F stand for the

1 built-in motor temperature, and T_G and T_H are used for detecting the back bearing temperature.
2 T_R corresponds to the room temperature. Besides, the setting methods of the spindle inspection
3 bar and eddy current displacement sensors are shown in Fig. 9: they are located onto the spindle,
4 according to the standard measuring method of spindle thermal errors ^[7].

5 **4.2 Experimental Method**

6 In order to illustrate the advantage of constant supply cooling powers strategy, the built-in
7 motorized spindle is required to be equipped with traditional bath recirculation cooler and
8 differentiated multi-loops bath recirculation system respectively. In experiments, the room
9 temperature tracing strategy is accomplished based on the traditional bath recirculation cooler,
10 and the constant supply cooling powers strategy is accomplished based on the differentiated
11 multi-loops bath recirculation system. In the environment with a consistent room temperature
12 ($T_R=20\pm 0.3\text{ }^\circ\text{C}$), the experimental operation of built-in motorized spindle lasts for 5 hours. In
13 the same running condition of built-in motorized spindle, its experimental thermal behaviors
14 (temperature and thermal errors) caused by the constant supply cooling powers strategy will be
15 contrasted with the ones caused by the room temperature tracing strategy. Crucially, the
16 effectiveness of contrasting experimental verification above is based on the prerequisite: Onto
17 every heat generating part, the same average cooling power is applied under both 2 strategies
18 above in spindle operation.

19 Besides, the contrasting experiments are done in 2 running conditions of spindle: constant
20 and progressive speed rotation cases. The aim is to get the comprehensive verification for the
21 effectiveness of the proposed constant supply cooling powers strategy. As shown in Fig. 10, in
22 the constant speed rotation case, the built-in motorized spindle is in 3000RPM operation for 5
23 hours; but in the progressive speed rotation case, the spindle is running from 1000RPM to
24 5000RPM (increasing step is 1000RPM), every speed condition lasts for 1 hour ^[8].

25 **4.3 Experimental Results and Discussions**

26 The obtained experimental thermal behaviors of built-in motorized spindle are shown and
27 analyzed as follows, so as to verify the advantage of constant supply cooling powers strategy
28 based on differentiated multi-loops bath recirculation system.

29 **4.3.1 Supply Temperatures**

30 Compared with the traditional bath recirculation cooler, the differentiated multi-loops bath

1 recirculation system has an obvious characteristic: The differentiated supply temperatures onto
2 different spindle heat generating parts. As illustrated in Fig. 11, in progressive speed rotation
3 case, constant supply cooling powers strategy makes various and time-varying coolant supply
4 temperatures onto different heat generating parts of built-in motorized spindle. However, the
5 coolant supply temperatures caused by room temperature tracing strategy are uniform and
6 constant (equal to room temperature $20\pm 0.3\text{ }^{\circ}\text{C}$). This shows that the cooling effects from
7 differentiated multi-loops bath recirculation system are more flexible. Because the heat powers
8 of different heat generating parts always have different scales, the differentiated supply
9 temperatures are more advantageous in stabilization of machine temperature and decrease of
10 thermal errors. This conclusion can be obtained in the constant speed rotation case of built-in
11 motorized spindle as well.

12 **4.3.2 Temperature Differences between Outlet and Inlet of Spindle Coolant Channels**

13 The real-time temperature differences between outlet and inlet of 3 spindle coolant channels
14 (for front bearings, motor, back bearing) are detected in experiments. It can be seen from Fig.12
15 (a) that, temperature differences caused by room temperature tracing cooling strategy is
16 time-increasing. This situation occurs based on the traditional bath recirculation cooler, and in
17 progressive speed rotation case of built-in motorized spindle. The density ρ and special heat c
18 of the coolant adopted in this paper are 910 kg/m^3 and 2090 J/(kg K) . According to equation
19 (1), owing to the constant supply volume flow rates, time-increasing temperature differences
20 mean time-increasing supply cooling powers.

21 In order to verify the advantage of constant supply cooling powers strategy, the differentiated
22 multi-loops bath recirculation system in experiment is required to do the cooling work whose
23 scale is similar with traditional bath recirculation cooler. That means the time-averaged supply
24 cooling powers onto spindle front bearings, motor, back bearing caused by room temperature
25 tracing strategy must be calculated. Then these 3 time-averaged supply cooling powers, being
26 objective constant supply cooling powers, are applied onto 3 spindle heat generating parts by
27 differentiated multi-loops bath recirculation system. In order to ensure the situation above, the
28 time-averaged temperature differences between outlet and inlet of 3 coolants caused by room
29 temperature tracing cooling strategy are calculated respectively, to be the objective temperature
30 differences of equation (2). Then this strategy can be accomplished by the differentiated
31 multi-loops bath recirculation system. As illustrated in Fig. 12(b), experimental temperature
32 differences of 3 coolants are almost reliable to their objective values. That means the supply
33 cooling powers onto 3 spindle heat generating parts are approximately constant with time. The

reason is that the density ρ , special heat c and supply volume flow rate Q of coolant in equation (1) are assumed to be constant with time. The same situation can be seen in the constant speed rotation case of built-in motorized spindle as well. The supply volume flow rates, time-averaged temperature differences between outlet and inlet of coolants, time-averaged supply cooling powers onto 3 spindle heat generating parts are listed in Table 1. These experimental parameters are in both the constant and progressive speed rotation cases.

4.3.3 Spindle Temperatures

When the built-in motorized spindle is in experimental operations, the spindle temperatures are continuously detected by RTD sensors in Fig.8. Then temperatures of front bearings, motor and back bearing are calculated by the averaging methods respectively:

$$T_{Fr} = \frac{1}{2}(T_A + T_B) \quad (3)$$

$$T_{Mo} = \frac{1}{4}(T_C + T_D + T_E + T_F) \quad (4)$$

$$T_{Ba} = \frac{1}{2}(T_G + T_H) \quad (5)$$

It can be seen from Figs. 13(a) that, in progressive speed rotation case, the spindle temperatures caused by room temperature tracing strategy are obviously increasing with time. Oppositely, the temperatures in Figs. 13 (b), brought by constant supply cooling powers strategy, are more stable and close to room temperature ($20 \pm 0.3^\circ\text{C}$). That shows: the same scale of cooling work having been done in 5 hours, constant supply cooling powers strategy is more effective than room temperature tracing cooling strategy in spindle temperature stabilization. This can be concluded from constant speed rotation case of built-in motorized spindle as well.

4.3.4 Spindle Thermal Errors

There are 3 translational thermal errors ($\delta_X/ \delta_Y/ \delta_Z$) of built-in motorized spindle being considered in this paper. After the experimental operations of the spindle, these 3 translational thermal errors can be calculated based on detected data of eddy current displacement sensors (shown in Fig. 9). The calculating methods^[7] are described in Fig. 14: Thermal deformations of Point O are seen as thermal errors of built-in motorized spindle. The thermal displacement from Sensor Z is the translational thermal error δ_Z of the spindle, and the translational thermal errors

1 δ_X and δ_Y can be calculated by these methods:

$$3 \quad \delta_X = \frac{\delta_{X(A)} - \frac{L_{OA}}{L_{OB}} \delta_{X(B)}}{\left(1 - \frac{L_{OA}}{L_{OB}}\right)} \quad (6)$$

$$4 \quad \delta_Y = \frac{\delta_{Y(A)} - \frac{L_{OA}}{L_{OB}} \delta_{Y(B)}}{\left(1 - \frac{L_{OA}}{L_{OB}}\right)} \quad (7)$$

5
6 In equations (6) and (7), $\delta_{X(A)}$, $\delta_{X(B)}$ and $\delta_{Y(A)}$, $\delta_{Y(B)}$ are thermal displacements detected by
7 Sensors X(A), X(B) and Y(A), Y(B); L_{OA} and L_{OB} are distances from Point O to A and from
8 Point O to B respectively on the spindle inspection bar. After these calculations, translational
9 thermal errors caused by constant supply cooling powers strategy are contrasted with the ones
10 caused by room temperature tracing strategy. Fig. 15 shows the contrasting in constant and
11 progressive speed rotation cases respectively. It can be seen from the figures that, spindle
12 thermal errors are increasing with time. Meanwhile, the maximum values of thermal errors
13 caused by constant supply cooling powers strategy are lower than the ones caused by room
14 temperature tracing cooling strategy. This condition can be concluded in both the constant and
15 progressive speed rotation cases. That is to say, compared with the room temperature tracing
16 strategy, constant supply cooling powers strategy can effectively reduce spindle thermal errors.
17 The reducing percentages are listed in Table. 2. These percentages reflect the advantage of
18 constant supply cooling powers strategy based on differentiated multi-loops bath recirculation
19 system in decrease of spindle thermal errors.

20 **5 Conclusions and Prospects**

21 This paper introduces a differentiated multi-loops bath recirculation system, which can
22 accomplish the differentiated and close-loop cooling strategies onto different heat generating
23 parts of precision machine tools. In order to verify the advantages of this system, the constant
24 supply cooling powers strategy is described and applied onto a certain type of built-in
25 motorized spindle for the experiments. The advantages of the proposed strategy based on the
26 differentiated multi-loops bath recirculation system are verified in the experiments. In summary,
27 conclusions of the paper are as follows:

28 (1) The differentiated multi-loops bath recirculation system can accomplish the differentiated

1 and close-loop cooling strategies onto different heat generating parts of precision machine tools.
2 Compared with traditional bath recirculation cooler, it is more flexible and advantageous in the
3 controls of temperature field and thermal errors of precision machine tools.

4 (2) The constant supply cooling powers strategy can be accomplished based on differentiated
5 multi-loops bath recirculation system. It brings constant supply cooling powers onto heat
6 generating parts in machine operation. Compared with room temperature tracing strategy based
7 on traditional bath recirculation cooler, it is more effective in stabilizing machine temperature
8 field and reducing thermal errors, which has been verified by the contrasting experiments onto
9 the built-in motorized spindle.

10 Study prospects: Besides the constant supply cooling powers strategy developed, it may be
11 speculated that there will probably be other differentiated and close-loop cooling strategies for
12 precision machine tools. The further studies about differentiated multi-loops bath recirculation
13 system will concentrate on some new cooling strategies in decrease of machine tool errors.

14 **Acknowledgements**

15 This study work is supported by a grant from the National High Technology Research and
16 Development Program of China (No. 2012AA040701).

17 **References**

- 18 [1] M. Weck, P. McKeown, R. Bonse, U. Herbst, Reduction and Compensation of Thermal
19 errors in Machine Tools. *CIRP Annals-Manufacturing Technology* 44 (1995) 589-598
20 [2] J. Bryan, International Status of Thermal errors Research. *CIRP Annals-Manufacturing*
21 *Technology* 39 (1990) 645-656
22 [3] C. Chou, D. B. DeBra, Liquid Temperature Control for Precision Tools. *CIRP*
23 *Annals-Manufacturing Technology* 39 (1990) 535-543
24 [4] M. A. Donmez, M. H. Hahn, J. A. Soons, A Novel Cooling System to Reduce Thermally
25 Induced Errors of Machine Tools. *CIRP Annals-Manufacturing Technology* 56 (2007)
26 521-524
27 [5] J. Jędrzejewski, W. Kwasny, Study on Reducing Energy Consumption in Manufacturing
28 Systems. *Journal of Machine Engineering* 11 (2011) 7-20
29 [6] S. W. Lee, H. K. Yeom, H. K. Lee, Improvement of Temperature Accuracy in Oil Cooler
30 System with Gas Bypass. *International Journal of Precision Engineering and*
31 *Manufacturing* 12 (2011) 39-45

1 [7] ISO 230-3 2007, Test Code for Machine Tools--Part 3 Determination of Thermal Effects
2 [8] A. Statham, A. Martin, D. M. S. Blackshaw, Assessing the Thermal Distortion Caused by
3 Spindle Rotation of a Machining Center Using Draft Standard ISO/DIS 230-3. Laser
4 Metrology and Machining Performance III 16 (1997) 101-111

5

6

7

8

9

10

11

12

13

14

15

16

-
- 1 **Figure and Table captions**
- 2 Figure 1- Structure and principle of differentiated multi-loops bath recirculation system
- 3 Figure 2- Accomplishment of differentiated supply temperature in branch
- 4 Figure 3- Accomplishment of differentiated supply volume supply rate in branch
- 5 Figure 4- Signal instructions conveying to control units
- 6 Figure 5- Heat generating parts and coolant channels inside built-in motorized spindle
- 7 Figure 6- Differentiated multi-loops bath recirculation cooling platform for built-in motorized
- 8 spindle
- 9 Figure 7- Experimental schematic
- 10 Figure 8- Layout of RTD sensors
- 11 Figure 9- Setting method of eddy current displacement sensors
- 12 Figure 10- Running conditions of built-in motorized spindle in experiments
- 13 Figure 11- Contrasting of supply temperatures (Progressive speed rotation case)
- 14 Figure 12- Contrasting of temperature differences between outlet and inlet of spindle coolants
- 15 (Progressive speed rotation case)
- 16 Figure 13- Contrasting of spindle temperatures (Progressive speed rotation case)
- 17 Figure 14- Calculations of spindle thermal errors based on the detections of eddy current
- 18 displacement sensors
- 19 Figure 15- Contrasting of thermal errors of built-in motorized spindle caused by different cooling
- 20 strategies
- 21 Table 1- Cooling parameters for built-in motorized spindle in experiments
- 22 Table 2- Reducing percentages of spindle thermal errors caused by constant supply cooling
- 23 powers strategy (compared with room temperature tracing strategy)
- 24
- 25

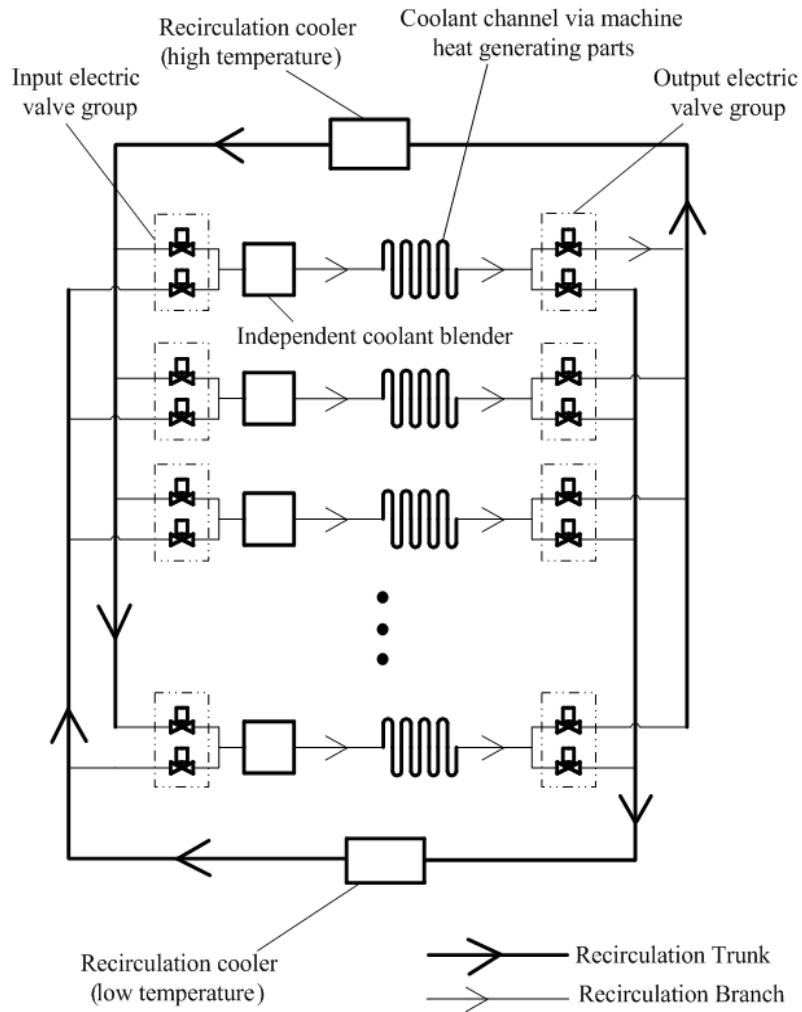

1

2

Fig. 1 Structure and principle of differentiated multi-loops bath recirculation system

3

4

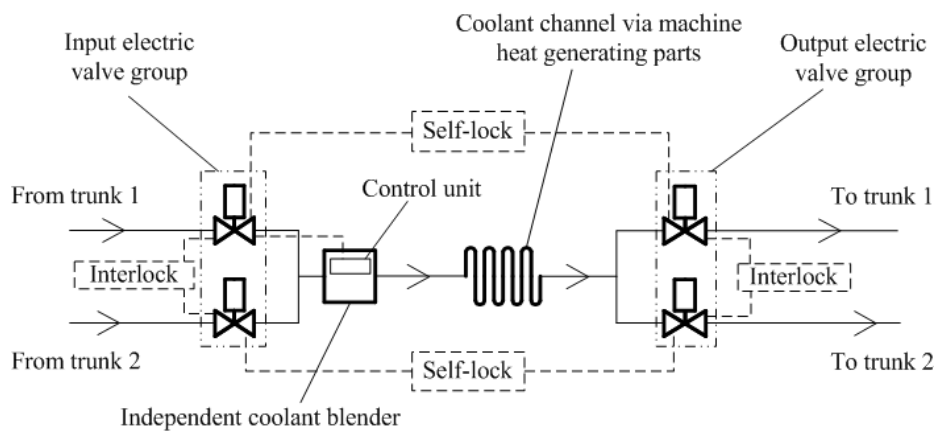

5

6

Fig. 2 Accomplishment of differentiated supply temperature in branch

7

8

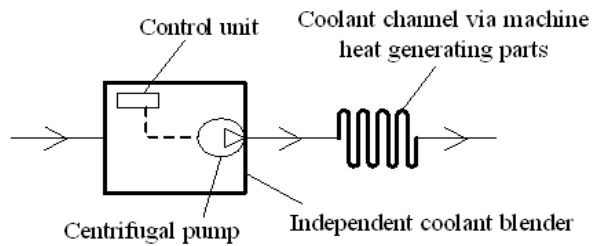

1
2
3
4
5
6
7
8
9
10
11
12

Fig. 3 Accomplishment of differentiated supply volume supply rate in branch

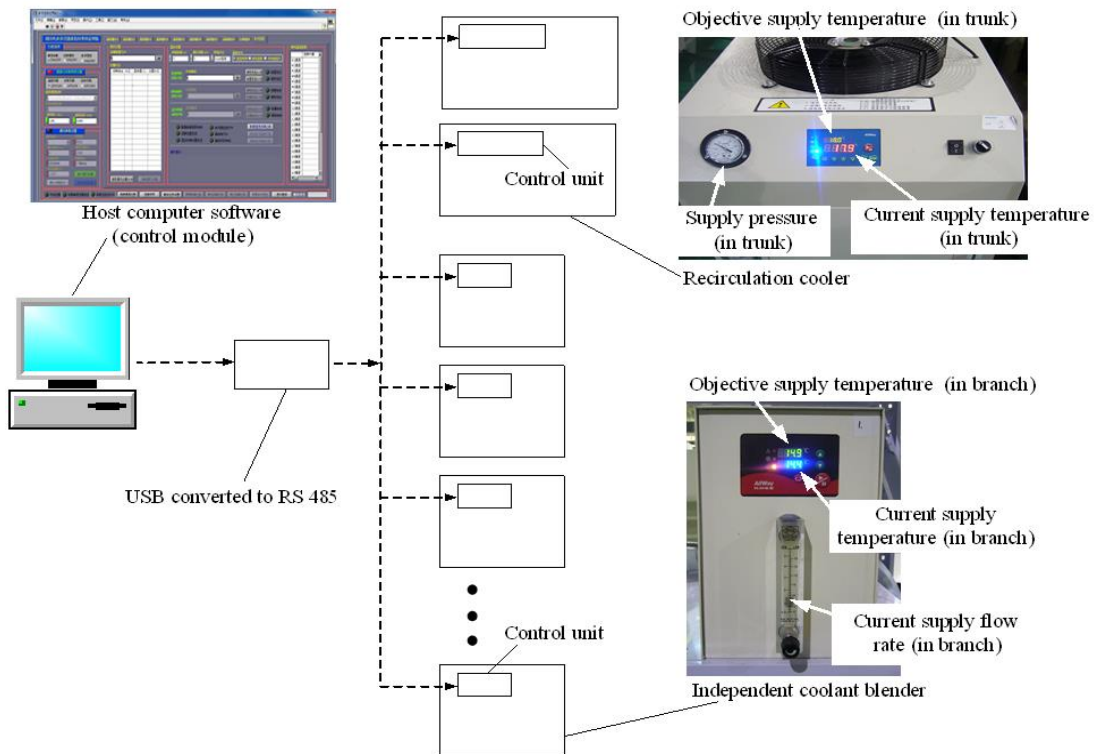

13
14
15

Fig. 4 Signal instructions conveying to control units

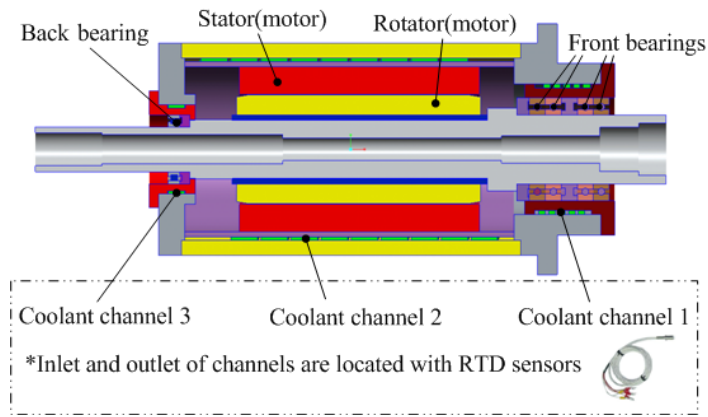

1
2
3
4
5
6
7
8
9
10
11

Fig. 5 Heat generating parts and coolant channels inside built-in motorized spindle

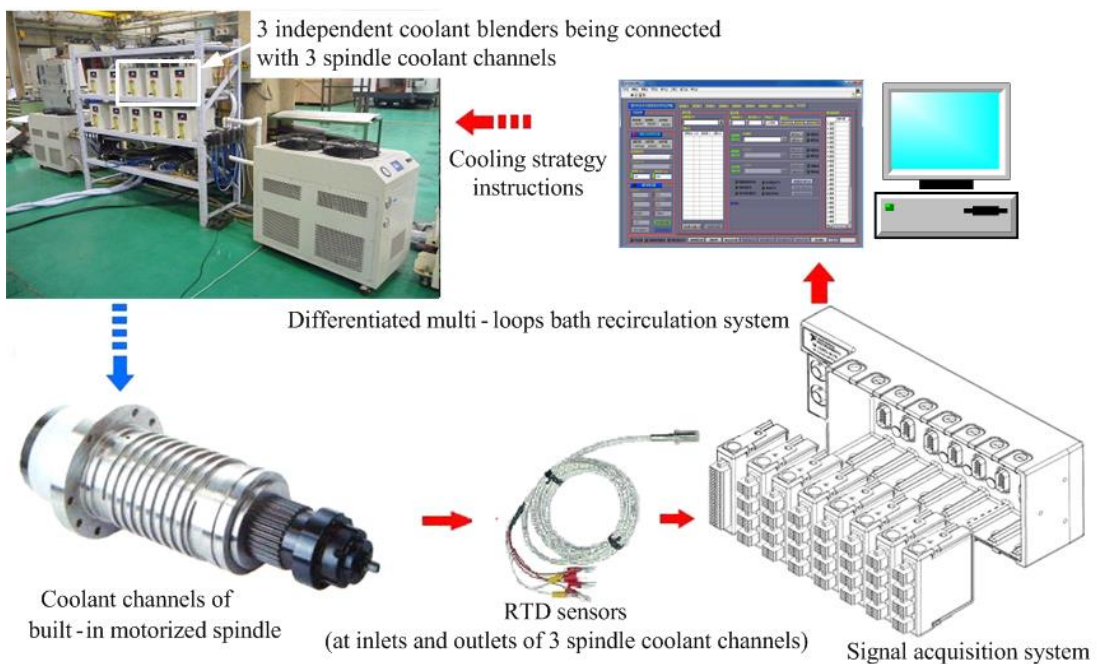

12
13
14
15

Fig. 6 Differentiated multi-loops bath recirculation cooling platform for built-in motorized spindle

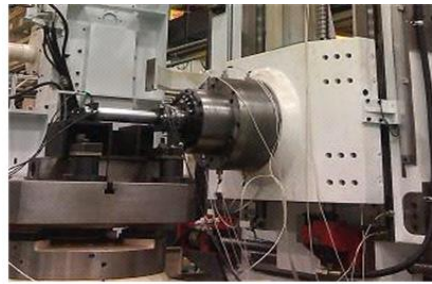

Built-in motorized spindle

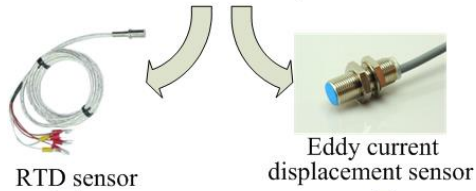

RTD sensor

Eddy current displacement sensor

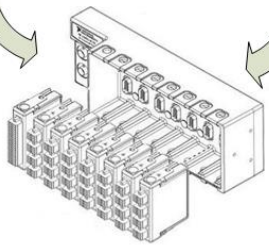

Signal acquisition system



Host computer software
(monitoring module)

1

2

3

Fig. 7 Experimental schematic

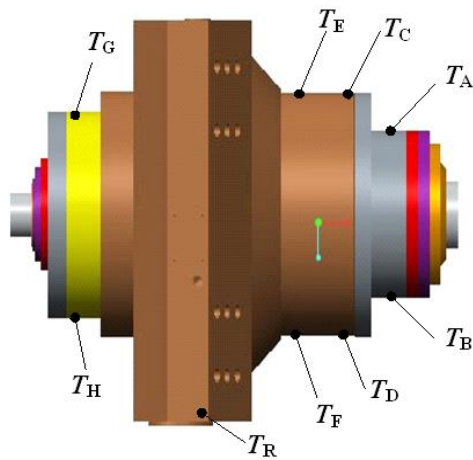

4

5

Fig. 8 Layout of RTD sensors

1

2

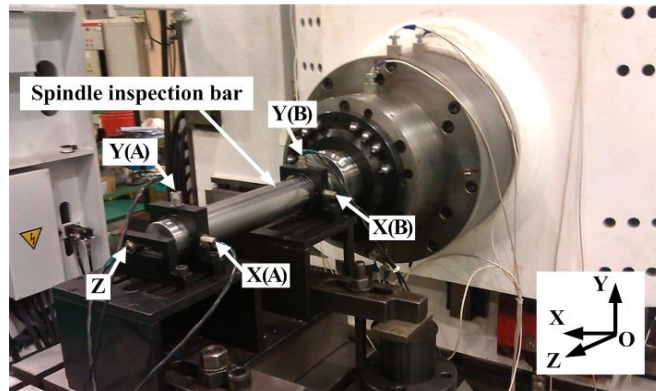

3

4

Fig. 9 Setting method of eddy current displacement sensors

5

6

7

8

9

10

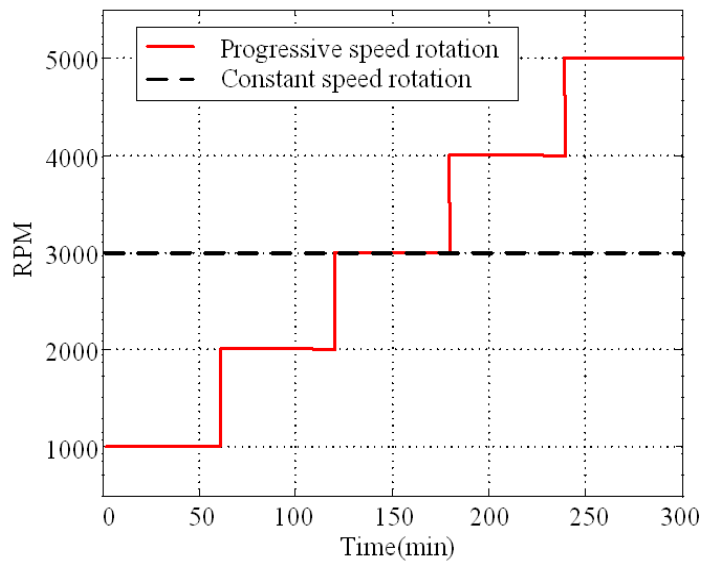

11

12

Fig. 10 Running conditions of built-in motorized spindle in experiments

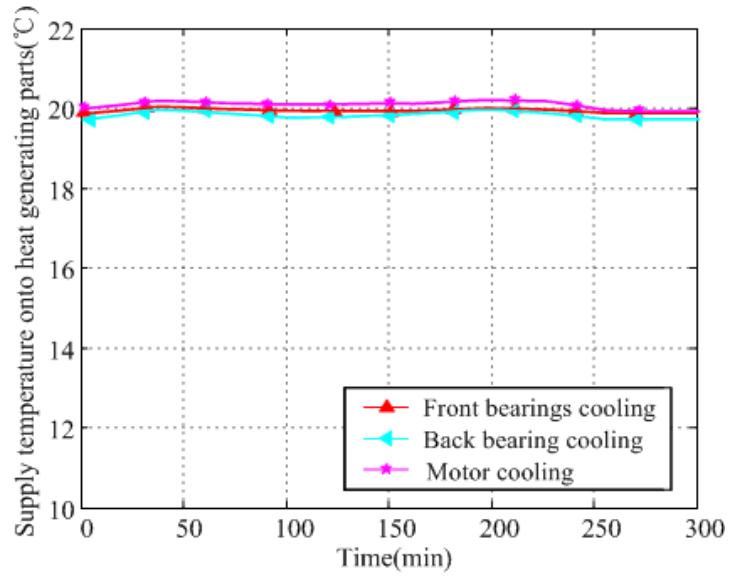

(a) Room temperature tracing strategy

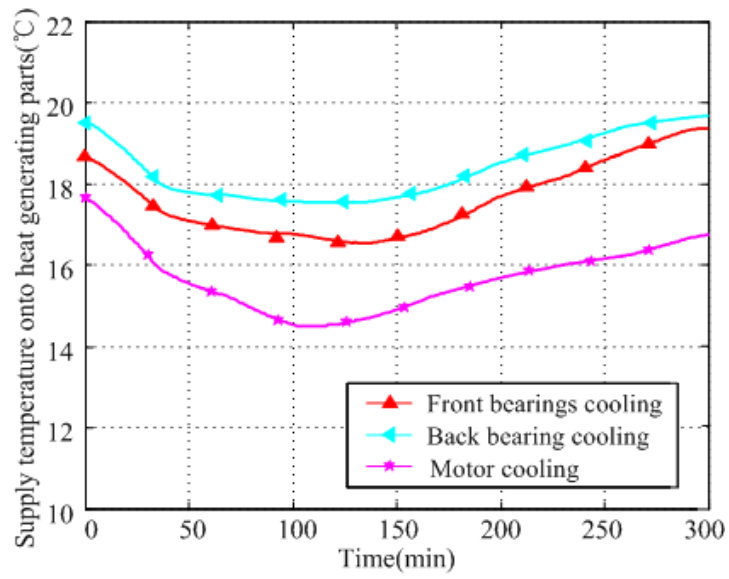

(b) Constant supply cooling powers strategy

1 Fig. 11 Contrasting of supply temperatures (Progressive speed rotation case)

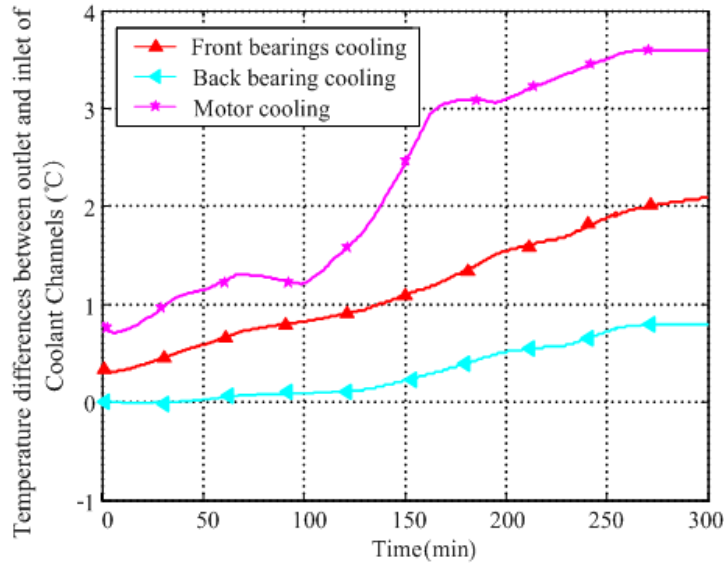

(a) Room temperature tracing strategy

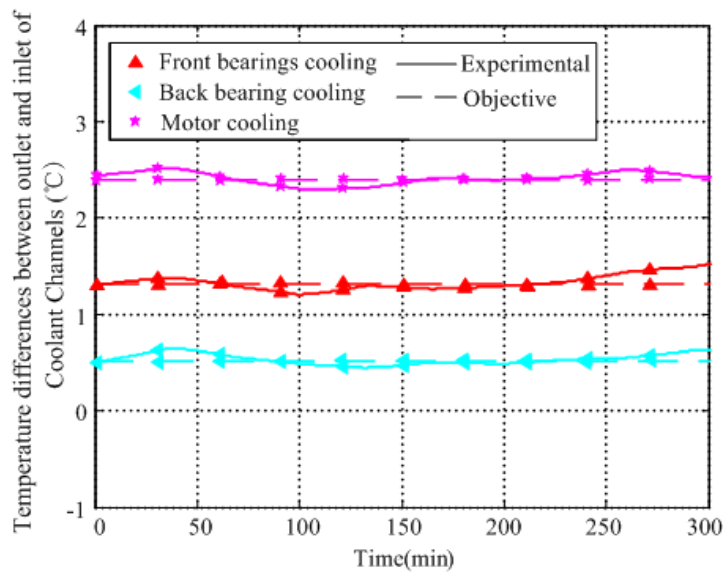

(b) Constant supply cooling powers strategy

1 Fig. 12 Contrasting of temperature differences between outlet and inlet of spindle coolants
 2 (Progressive speed rotation case)

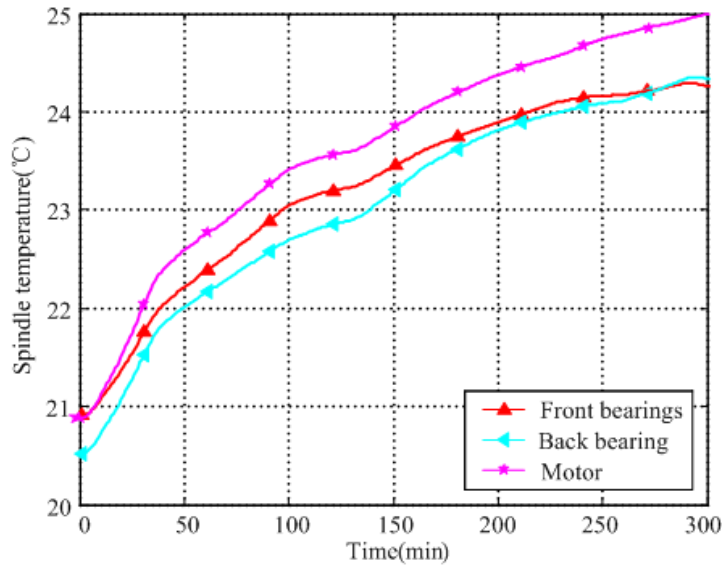

(a) Room temperature tracing strategy

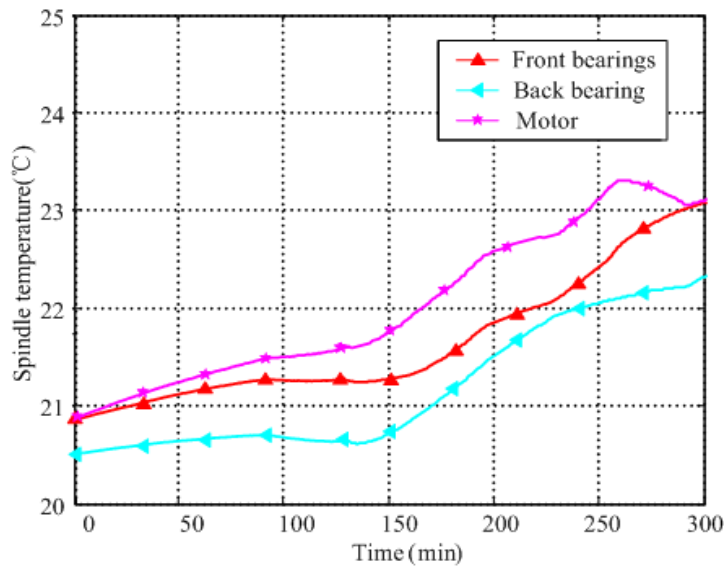

(b) Constant supply cooling powers strategy

1 Fig. 13 Contrasting of spindle temperatures (Progressive speed rotation case)

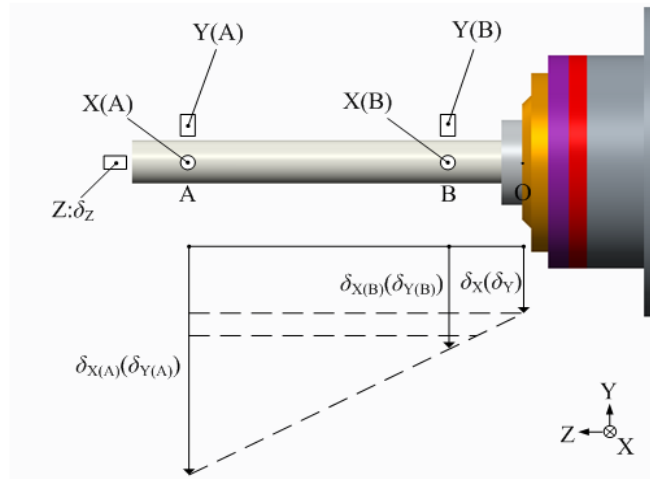

1

2

Fig. 14 Calculations of spindle thermal errors based on the detections of eddy current displacement sensors

3

4

5

6

7

8

9

10

11

12

13

14

15

16

17

18

19

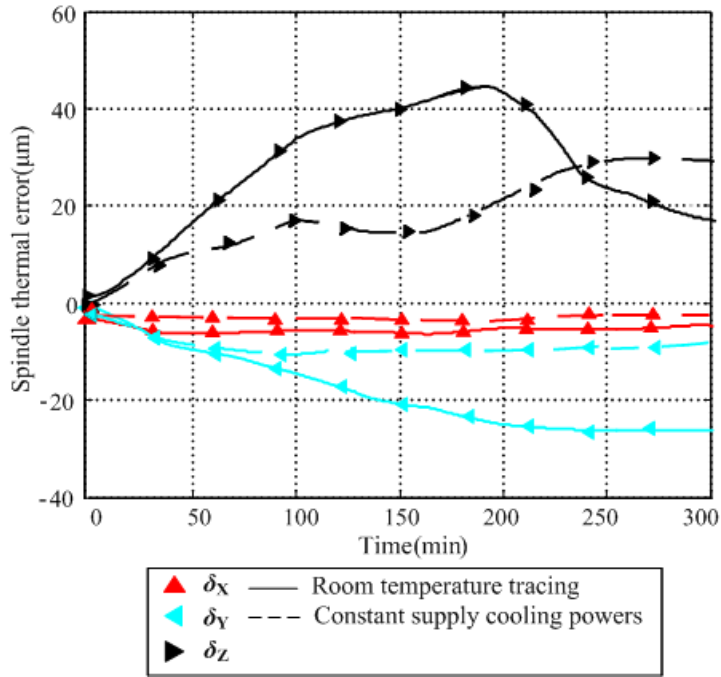

(a) Constant speed rotation case

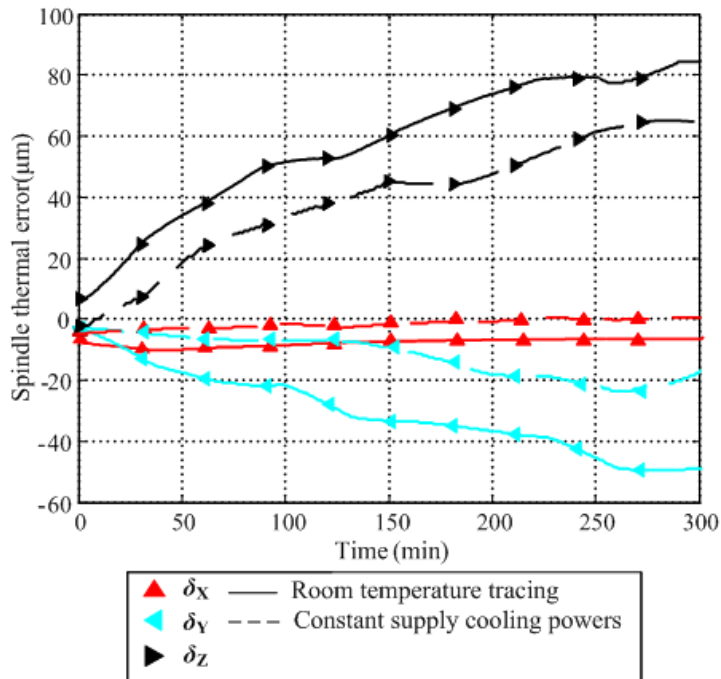

(b) Progressive speed rotation case

1 Fig. 15 Contrasting of thermal errors of built-in motorized spindle caused by different cooling
 2 strategies

3

1 Table 1. Cooling parameters for built-in motorized spindle in experiments

	Coolant for front bearings	Coolant for built-in motor	Coolant for back bearing
Supply volume flow rate (L/min)	4	5	3
Time-averaged temperature difference between outlet and inlet of coolants, constant speed rotation case (°C)	1	2.6	0.4
Time-averaged temperature difference between outlet and inlet of coolants, progressive speed rotation case (°C)	1.3	2.4	0.5
Time-averaged supply cooling power, constant speed rotation case (W)	126.8	412.1	38.0
Time-averaged supply cooling power, progressive speed rotation case (W)	164.8	380.4	47.5

2
3
4 Table 2. Reducing percentages of spindle thermal errors caused by constant supply cooling
5 powers strategy (compared with room temperature tracing strategy)

	δ_x	δ_y	δ_z
Constant speed rotation case	51.3%	64.3%	37.2%
Progressive speed rotation case	61.7%	52.5%	22.6%

6
7