

# Classification of singular fibres of stable maps from 4-manifolds to 3-manifolds and its applications

Takahiro Yamamoto\*

December 10, 2003

## Abstract

In this paper we classify the singular fibres of a stable maps from a closed 4-manifolds to a 3-manifolds up to the right-left equivalence. Furthermore, we obtain several results on the co-existence of the singular fibres of such maps. As a consequence, we show that Euler characteristic of the source 4-manifold with the suitable condition, has the same parity as the total number of specified singular fibres. In orientable case, the crucial result is obtained by O.Saeki [14]. The main theorem of this paper is a generalization of his theorem.

2000 *Mathematics Subject Classification*. Primary 57R45; Secondary 57N13

*Key words*. Stable map, singular fibre, Euler characteristic, two color decomposition.

## 1 Introduction

As pioneer, L.Kushner, H.Levine and P.Port studied the singular fibres of stable maps from a closed 3-manifold to plane, in [6]. But it seems that they did not state clearly the definition of singular fibre and equivalence relation among the fibres. Recently, in the paper [14], O.Saeki stated the precise definition of singular fibres, introduced the equivalence relation among singular fibres and classified the singular fibres of a stable map from a closed orientable 4-manifolds to a 3-manifolds. Moreover he proved the following: For any stable map  $f : M^4 \rightarrow N^3$  from an orientable closed 4-manifold  $M^4$  to a connected 3-manifold  $N^3$ , the number of singular fibre as in Figure 1 and Euler characteristic of  $M^4$  are of the same parity.

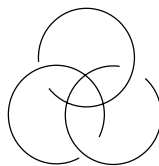

Figure 1:

Then naturally we ask:

---

\*taku\_chan@math.sci.hokudai.ac.jp

*Are there any formula of same type when source manifold is non-orientable ?*

In this paper we give the classification of singular fibres including non-orientable cases, for a stable maps from a closed 4 manifolds to a 3-manifolds; Figure 6, 7. Moreover we present a partial answer to the above question; Theorem 1.1.

**Theorem 1.1** *Let  $f : M^4 \rightarrow N^3$  be a stable map from a closed 4-manifold  $M^4$  to a connected 3-manifold  $N^3$ . If  $f$  satisfies either  $H_1(N, \mathbb{Z}_2) = 0$  or  $f_*[S(f)] = 0 \in H_2(N, \mathbb{Z}_2)$ , then we have*

$$\begin{aligned} \chi(M) \equiv & |III^{0,2,2}(f)| + |III^{1,2,2}(f)| + |III^{2,2,2}(f)| + |III^{0,7}(f)| \\ & + |III^{1,7}(f)| + |III^{2,6}(f)| + |III^{2,7}(f)| + |III^{12}(f)| \\ & + |III^{18}(f)| + |III^{19}(f)| + |III^{25}(f)| + |III^{26}(f)| \\ & + |III_A^{13}(f)| \pmod{2} \end{aligned}$$

where  $S(f) \subset M$  denotes the singular points set of  $f$ ,  $\chi(M)$  denotes Euler characteristic of  $M$  and, each  $|III^*(f)|$  is the number of the singular fibre of  $III^*$  type in Figure 6 and 7.

We note that  $f(S(f))$  is an embedded 2 dimensional simplicial complex in  $N$ . Now  $N$  is stratified by the fibre of types of the right-left equivalence. Then the set of regular values  $N \setminus f(S(f))$  consists of 3-strata while the set of singular values  $f(S(f))$  consists of 2, 1 and 0-strata. Then we assign each 3-strata in  $N \setminus f(S(f))$  the number of connected components of fibres. We note that the number is constant at any point on each stratum.

On the other hand, the assumption of Theorem 1.1,  $H_1(N, \mathbb{Z}_2) = 0$  or  $f_*[S(f)] = 0 \in H_2(N, \mathbb{Z}_2)$ , is a two colorable condition for  $N \setminus f(S(f))$ . Under this assumption, for any point in  $f(S(f))$ , we notice that the coloring of 3-strata which are adjacent to the point. We combine the color of the adjacent 3-strata and the corresponding number of connected components of the fibres. Then we can further divide several classes of singular fibres by right-left equivalence into 2 types  $A, B$ .

We note that the number of the singular fibre of  $III^{13}$  type is even for an arbitrary stable maps  $f : M^4 \rightarrow N^3$  between as above manifolds. Consequently,  $|III_A^{13}(f)|$  and  $|III_B^{13}(f)|$  has same parity. Therefore in Theorem 1.1 we may replace  $III_A^{13}(f)$  by  $III_B^{13}(f)$ . If  $M$  is orientable then  $f_*[S(f)]$  always vanishes, namely the assumption of theorem is automatically fulfilled. Then the singular fibres of  $III^{0,2,2}$ ,  $III^{1,2,2}$ ,  $III^{2,2,2}$ ,  $III^{0,7}$ ,  $III^{1,7}$ ,  $III^{2,6}$ ,  $III^{2,7}$ ,  $III^{13}$ ,  $III^{18}$ ,  $III^{19}$ ,  $III^{25}$  and  $III^{26}$  types never appear. Thus Theorem 1.1 gives the O.Saeki's result when the source manifold is orientable. It seems to be interesting to remark that just the singular fibre of  $III^{13}$  type are labeled A (or B), in our formula.

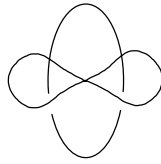

Figure 2: The interesting singular fibre  $III^{13}$  in Theorem 1.1

In the paper [5], M.Kobayashi constructed the stable map  $g : \mathbb{C}P^2 \rightarrow \mathbb{R}^3$  whose  $g(S(g))$  has two triple points, each of them is  $III^{0,0,0}$  or  $III^{12}$ . Theorem 1.1 implies that  $\chi(\mathbb{C}P^2)$  is odd

number. In fact  $\mathbb{C}P^2$  is orientable and  $\chi(\mathbb{C}P^2) = 3$ . In the paper [12], O.Saeki constructed a non-orientable closed 4-manifold  $E$  and a fibration  $p : E \rightarrow \mathbb{R}P^2$  whose fibre is  $\mathbb{R}P^2$ . He also constructed the stable map  $h : E \rightarrow \mathbb{R}^3$  whose  $h(S(h))$  has 27 triple points. They consist of 8  $\text{III}^{0,0,0}$  points, 12  $\text{III}^{0,0,2}$  points, 6  $\text{III}^{0,2,2}$  points, and one  $\text{III}^{2,2,2}$  point. Theorem 1.1 show that  $\chi(E)$  must be an odd number.

This paper is organized as follows. In §2, we give definitions of the equivalence relations among the fibres of a stable map. In §3, we classify the singular fibres up to  $C^\infty$  equivalence, and give the tables of the singular fibres for the stable maps from a closed 4-manifolds to a 3-manifolds. In §4, we give some co-existence relation of singular fibres for the stable maps from a closed 4-manifolds to a 3-manifolds. In §5, we show that Euler characteristic of the source manifold have the same parity of the total number of the specified singular fibres, Theorem 1.1, and Proposition 5.4.

Throughout this paper, all manifolds and maps are  $C^\infty$  class unless state otherwise, and  $\chi$  denote Euler characteristic and, for finite set  $X$  we denote by  $|X|$  the number of its elements. In this paper, we call the connected elements of stratification *stratum*.

The author would like to thank Professor Osamu Saeki for his valuable comments and constant encouragement. The author would like to thank Professor Go-o Ishikawa for continusly encouragement and advice.

## 2 Preliminaries

Let us begin by some fundamental definitions. They will be very important for the classification of the singular fibres of a stable map  $f : M \rightarrow N$  such that  $\dim M > \dim N$ .

**Definition 2.1** *Let  $M_i$  be smooth manifolds and  $A_i$  be subsets of  $M_i$ ,  $i=0,1$ . A continuous map  $g : A_0 \rightarrow A_1$  is said to be smooth if for every point  $q \in A_0$ , there exists a smooth map  $\tilde{g} : V \rightarrow M_1$  defined on a neighborhood  $V$  of  $q$  in  $M_0$  such that  $\tilde{g}|_{V \cap A_0} = g|_{V \cap A_0}$ . And, a smooth map  $g : A_0 \rightarrow A_1$  is a diffeomorphism if it is a homeomorphism and its inverse is also smooth.*

*Let  $f_i : M_i \rightarrow N_i$  be smooth maps,  $i=0,1$ . For  $q_i \in N_i$ , we say that the fibres over  $q_0$  and  $q_1$  are diffeomorphic if  $(f_0)^{-1}(q_0) \subset M_0$  and  $(f_1)^{-1}(q_1) \subset M_1$  are diffeomorphic in the above sense. Furthermore, we say that the fibres over  $q_0$  and  $q_1$  are  $C^\infty$  equivalent or right-left equivalent, if for some open neighborhood  $U_i$  of  $q_i$ , there exist diffeomorphisms  $\Phi : (f_0)^{-1}(U_0) \rightarrow (f_1)^{-1}(U_1)$  and  $\varphi : U_0 \rightarrow U_1$  which make the following diagram:*

$$\begin{array}{ccc} ((f_0)^{-1}(U_0), (f_0)^{-1}(q_0)) & \xrightarrow{\Phi} & ((f_1)^{-1}(U_1), (f_1)^{-1}(q_1)) \\ f_0 \downarrow & & \downarrow f_1 \\ (U_0, q_0) & \xrightarrow{\varphi} & (U_1, q_1) \end{array}$$

*is commutative.*

If  $q \in N$  is a regular value of a differential map  $f : M \rightarrow N$  between manifolds, we call  $f^{-1}(q)$  a *regular fibre*; otherwise, a *singular fibre*.

### 3 Singular fibres of stable map from 4-manifold to 3-manifold

In this section we recall the characterization of the stable maps from a closed 4-manifolds to a 3-manifolds. In general, we say  $f \in C^\infty(M, N)$  is stable if  $\mathcal{A}$ -orbit of  $f$  is open in  $C^\infty(M, N)$  with respect to the Whitney  $C^\infty$ -topology. Here  $\mathcal{A}$ -orbit of  $f \in C^\infty(M, N)$  means as follows. Let  $\text{Diff}(N)$  denote the group which consists of all diffeomorphisms  $\Psi : N \rightarrow N$ . Then  $\text{Diff}(M) \times \text{Diff}(N)$  acts on  $C^\infty(M, N)$  as  $(\Phi, \Psi)f = \Psi \circ f \circ \Phi^{-1}$ , where  $(\Phi, \Psi) \in \text{Diff}(M) \times \text{Diff}(N)$  and  $f \in C^\infty(M, N)$ . Then  $\mathcal{A}$ -orbit of  $f \in C^\infty(M, N)$  is the orbit through  $f$ .

**Proposition 3.1** *A differential map  $f : M \rightarrow N$  from a closed 4-manifold  $M$  to a 3-manifold  $N$  is  $C^\infty$ -stable if and only if the following conditions are satisfied.*

1. (local condition) *For every  $p \in M$ , there exist local coordinates  $(x, y, z, w)$  and  $(X, Y, Z)$  around  $p \in M$  and  $f(p) \in N$  respectively such that one of the following holds:*

$$(X \circ f, Y \circ f, Z \circ f) = \begin{cases} (x, y, z) & p : \text{regular point} \\ (x, y, z^2 + w^2) & p : \text{definite fold} \\ (x, y, z^2 - w^2) & p : \text{indefinite fold} \\ (x, y, z^3 + xz - w^2) & p : \text{cusp} \\ (x, y, z^4 + xz^2 + yz + w^2) & p : \text{definite swallow-tail} \\ (x, y, z^4 + xz^2 + yz - w^2) & p : \text{indefinite swallow-tail} \end{cases}$$

2. (global condition) *Set  $S(f) = \{p \in M \mid \text{rank } df_p < 3\}$ , which is a closed 2-dimensional submanifold of  $M$  under the above local condition. Then, for every  $q \in f(S(f))$ ,  $f^{-1}(q) \cap S(f)$  consists of at most three points and the multi-germ*

$$(f|_{S(f)}, f^{-1}(q) \cap S(f))$$

*is right-left equivalent to one of the six multi-germs as described in Figure 3, this figures represent local form of  $f(S(f))$  in  $N$ : (1) corresponds to a single fold point, (2) and (3) represent normal crossings two and three immersion germs, respectively, each of which corresponds to a fold point, (4) corresponds to a cusp point, (5) represents a transverse crossing of a cuspidal edge as in (4) and an immersion germ corresponding to a fold point, and (6) corresponds to a swallow-tail.*

Proposition 3.1 is proved similarly as [2, 3, 8].

Let  $p$  be a singular point of the stable map  $f : M \rightarrow N$  from a closed 4-manifold  $M$  to a 3-manifold  $N$ . Then, based on the local normal condition of Proposition 3.1 1, it is easy to determine the diffeomorphism type of the neighborhood of  $p$  in  $f^{-1}(f(p))$ .

**Lemma 3.2** *Every singular point  $p$  of a stable map  $f : M \rightarrow N$  from a closed 4-manifold  $M$  to a 3-manifold  $N$  has one of the following neighborhood in its corresponding singular fibre  $f^{-1}(f(p))$  (see Figure 4):*

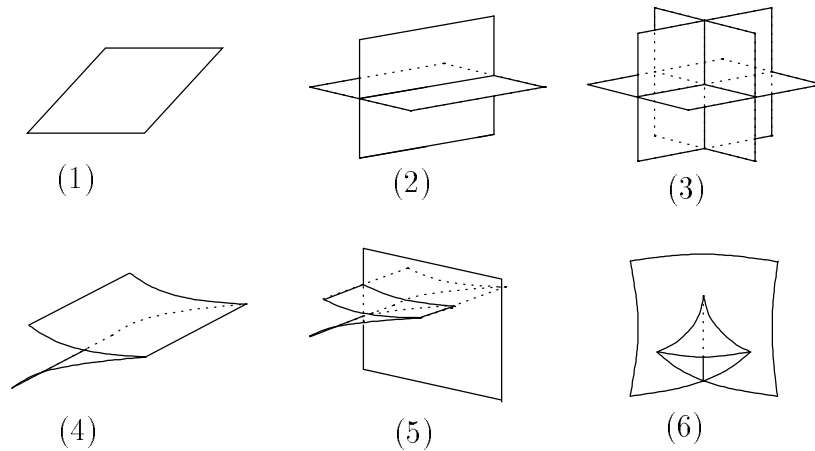

Figure 3: Multi-singularities of  $f|_{S(f)}$

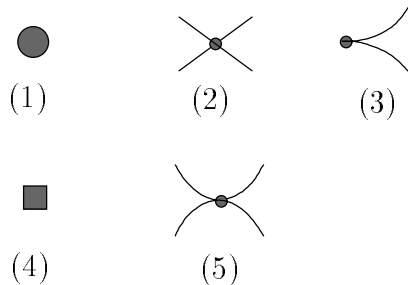

Figure 4: Neighborhood of a singular point in a singular fibre

1. isolated point diffeomorphic to  $\{(x, y) \in \mathbb{R}^2 \mid x^2 + y^2 = 0\}$ , if  $p$  is a definite fold point,
2. union of two transverse arcs diffeomorphic to  $\{(x, y) \in \mathbb{R}^2 \mid x^2 - y^2 = 0\}$ , if  $p$  is an indefinite fold point,
3. cuspidal arc diffeomorphic to  $\{(x, y) \in \mathbb{R}^2 \mid x^3 - y^2 = 0\}$ , if  $p$  is a cusp point,
4. isolated point diffeomorphic to  $\{(x, y) \in \mathbb{R}^2 \mid x^4 + y^2 = 0\}$ , if  $p$  is a definite swallowtail,
5. union of two tangent arcs diffeomorphic to  $\{(x, y) \in \mathbb{R}^2 \mid x^4 - y^2 = 0\}$ , if  $p$  is an indefinite swallowtail point.

We note that in Figure 4, both the black dot (1) and the black square (4) represent isolated points which are diffeomorphic but not right-left equivalent each other; we use the distinct symbols in order to distinguish them. And we note that each singular point  $p \in M$ , except for definite fold and definite swallow-tail points, is adjacent to some 1 dimensional simplexes in its neighborhood in  $f^{-1}(f(p))$ . We call these 1 dimension simplexes *hand* appeared from  $p$ . For the local nearby fibres, we have the following.

**Lemma 3.3** *Let  $f : M \rightarrow N$  be a stable map from a closed 4-manifold  $M$  to a 3-manifold  $N$  and  $p \in S(f)$  be a singular point such that  $f^{-1}(f(p)) \cap S(f) = \{p\}$ . Then the local fibres near  $p$  are described in Figure 5:*

1.  $p$  is a definite fold point,
2.  $p$  is an indefinite fold point,
3.  $p$  is a cusp point,
4.  $p$  is a definite fold point,
5.  $p$  is an indefinite fold point,

where each 1-dimensional object represents a portion of the fibre over the corresponding point in the target and each 2-dimensional object represents  $f(S(f)) \subset N$  near  $f(p)$ .

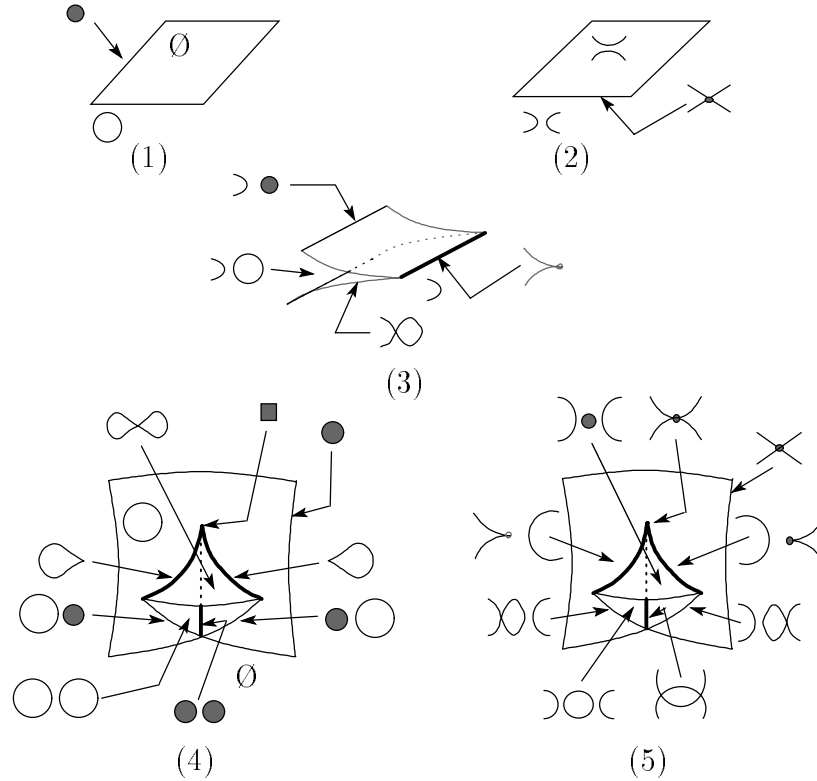

Figure 5: Local degeneration of fibres

Then, based on the global condition of Proposition 3.1 2, we join each hands appeared from each singular points in  $f^{-1}(f(p))$  and classify them. We have following.

**Theorem 3.4** *Let  $f : M \rightarrow N$  be a stable map from a closed 4-manifold  $M$  to a 3-manifold  $N$ . Then, every singular fibre of  $f$  is  $C^\infty$  equivalent to the disjoint union of one of the fibres as in Figure 6, 7 and finite number of circles.*

In Figure 6 and 7,  $\kappa$  denotes the codimension of the set of points in  $N$  whose corresponding fibres are  $C^\infty$  equivalent to the relevant one.

Let  $f : M \rightarrow N$  be as above. We note that, for every point  $q \in N$ , the map of germ  $(f, f^{-1}(q))$  is right-left equivalent to  $(\tilde{f}, id_{D^2}) : S \times D^2 \rightarrow I \times D^2$ , where  $S$  is 2-manifold with boundary,  $I$  is closed interval and  $\tilde{f}_t = \tilde{f}(\cdot, t) : S \rightarrow I$  is degenerate Morse function. We call  $S$

$\kappa = 1$

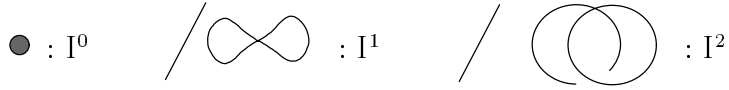

$\kappa = 2$

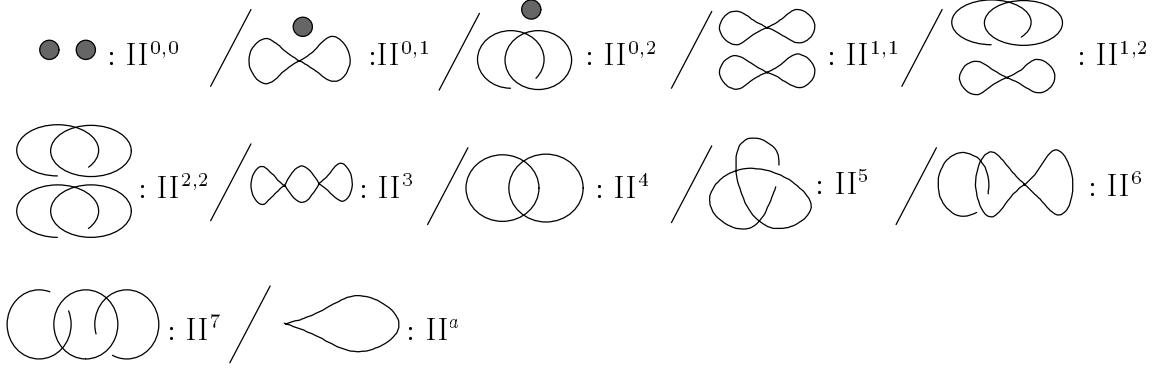

$\kappa = 3$

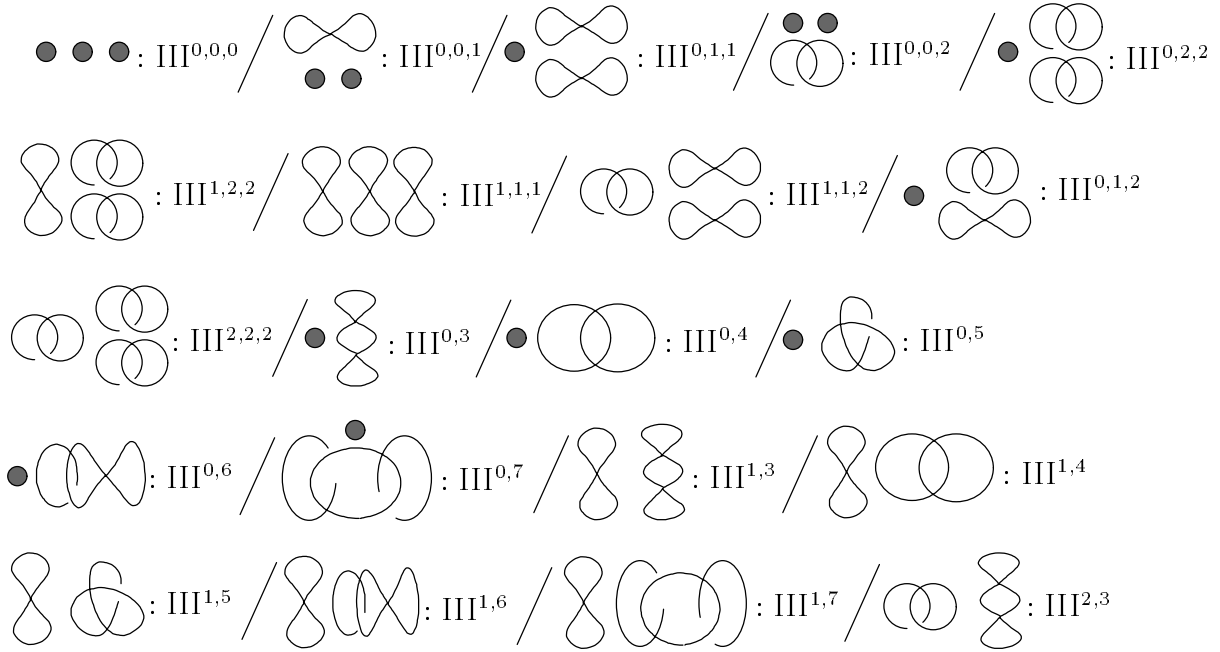

Figure 6: List of singular fibres; 1

$\kappa = 3$

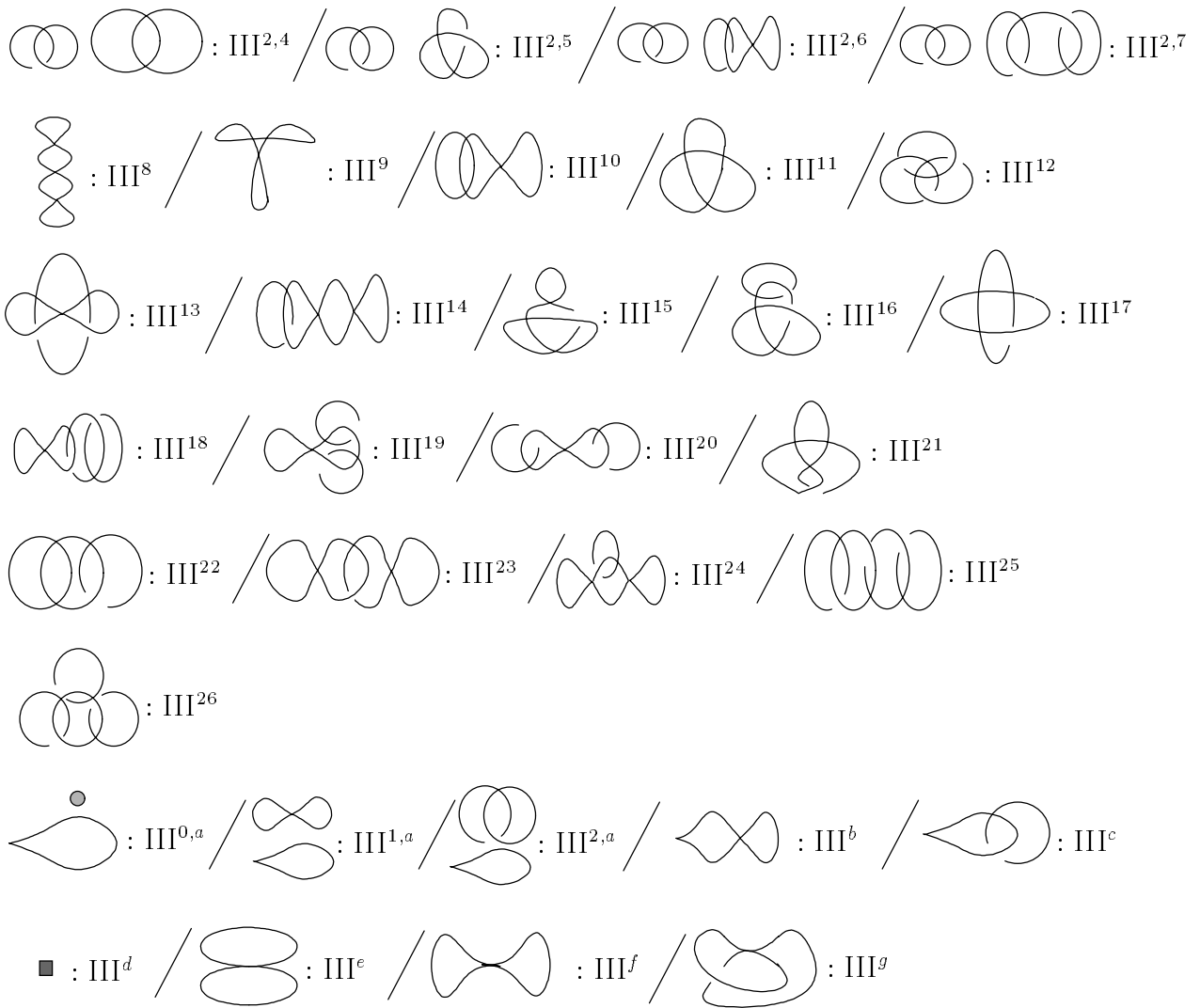

Figure 7: List of singular fibres; 2

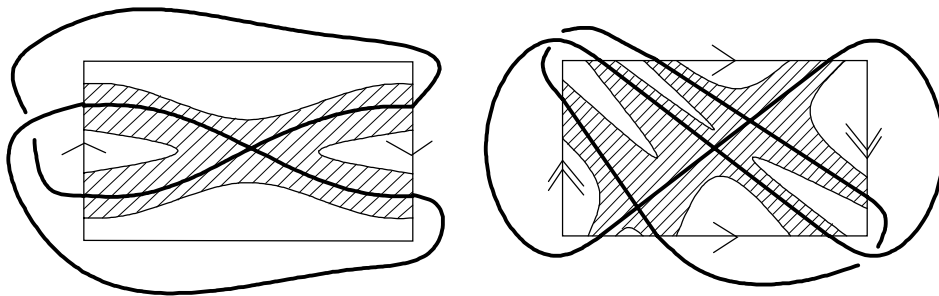

Figure 8: Left hand side is punctured Möbius band, right is Klein bottle with three holes



a *transverse surface* corresponding to the singular fibre  $f^{-1}(q)$ . For every singular fibre, there is stable map from a open 4-manifold  $M_0$  to  $\mathbb{R}^3$  which has certain singular fibre in this sense. Then we can extend the map to a smooth map from closed 4-manifold  $M$  containing  $M_0$  to  $\mathbb{R}^3$ . Perturbing the extended map slightly, we obtain a desired stable map. Theorem 3.4 is proved by constructing these transverse surface, see O.Saeki [14].

If the source 4-manifold is orientable then the transverse surface for an any singular fibre is orientable. On the other hand, if the source 4-manifold is non-orientable then there must be the singular fibre of  $I^2$  type. And the transverse surface which corresponds to the singular fibre of  $I^2$  type is punctured Möbius band, namely Möbius band with 1-hole; Figure 8.

We remark that for a stable map  $f : M \rightarrow N$  from an orientable closed 4-manifold  $M$  to a 3-manifold  $N$ , the singular fibres of the following types never appear since these fibres have non-orientable surface as corresponding transverse surface.  $I^2$ ,  $II^{0,2}$ ,  $II^{1,2}$ ,  $II^5$ ,  $II^6$ ,  $II^7$ ,  $III^{0,0,2}$ ,  $III^{0,2,2}$ ,  $III^{2,2,2}$ ,  $III^{1,1,2}$ ,  $III^{1,2,2}$ ,  $III^{0,5}$ ,  $III^{0,6}$ ,  $III^{0,7}$ ,  $III^{1,5}$ ,  $III^{1,6}$ ,  $III^{1,7}$ ,  $III^{2,3}$ ,  $III^{2,4}$ ,  $III^{2,5}$ ,  $III^{2,6}$ ,  $III^{2,7}$ ,  $III^{13}$ ,  $III^{14}$ ,  $III^{15}$ ,  $III^{16}$ ,  $III^{17}$ ,  $III^{18}$ ,  $III^{19}$ ,  $III^{20}$ ,  $III^{21}$ ,  $III^{22}$ ,  $III^{23}$ ,  $III^{24}$ ,  $III^{25}$ ,  $III^{26}$ ,  $III^{2,a}$ ,  $III^c$ , and  $III^g$ . For example, the transverse surface which corresponds to the singular fibre of  $III^{13}$  type is Klein bottle with three holes; Figure 8.

## 4 Relations among the numbers of singular fibres

Let  $f : M^4 \rightarrow N^3$  be a stable map from a closed 4-manifold  $M^4$  to a 3-manifold  $N^3$ . In this section, we consider a natural stratification of  $N^3$  induced by the  $C^\infty$  equivalence classes of fibres of  $f$ , and obtain some relations among the numbers of singular fibres of codimension three.

Let  $f : M^4 \rightarrow N^3$  be as above map, and  $\mathcal{F}$  be the  $C^\infty$  equivalence class of one of the singular fibres appearing in Figure 6, 7. We define  $\mathcal{F}(f)$  to be the set of points  $q \in N^3$  such that the fibre  $f^{-1}(q)$  over  $q$  is  $C^\infty$  equivalent to the union of  $\mathcal{F}$  and some circles. Then we obtain stratification of  $N$ . This stratification consists of  $\mathcal{F}(f)$  and  $N \setminus f(S(f))$  where  $\mathcal{F}$  runs all  $C^\infty$  equivalence of singular fibres in Figure 6, 7. Furthermore, we define  $\mathcal{F}(f)_o$  (resp.  $\mathcal{F}(f)_e$ ) to be the subset of  $\mathcal{F}(f)$  consisting of the points  $q \in \mathcal{F}(f)$  such that the number of connected components of the fibre is odd (resp. even). We denote the closures of  $\mathcal{F}(f)$ ,  $\mathcal{F}(f)_o$  and  $\mathcal{F}(f)_e$  in  $N$  by  $\overline{\mathcal{F}(f)}$ ,  $\overline{\mathcal{F}(f)_o}$  and  $\overline{\mathcal{F}(f)_e}$ , respectively. It is easy to see that each  $\overline{\mathcal{F}(f)}$ ,  $\overline{\mathcal{F}(f)_o}$  and  $\overline{\mathcal{F}(f)_e}$  is a  $(3 - \kappa)$  dimensional simplicial complex in  $N^3$ , where  $\kappa$  is the codimension of  $\mathcal{F}$ . In particular if the codimension  $\kappa$  is equal to two, then  $\overline{\mathcal{F}(f)_o}$  and  $\overline{\mathcal{F}(f)_e}$  are finite graphs embedded in  $N^3$ . Their vertices correspond to points over which a singular fibre with  $\kappa=3$  lies. For a equivalence class of the singular fibre  $\mathcal{G}$  of  $\kappa=3$ , the degree of the vertex corresponding to  $\mathcal{G}(f)_o$  (or  $\mathcal{G}(f)_e$ ) in the graph  $\overline{\mathcal{F}(f)_o}$  is given by Table 1, 2, 3. These tables are obtained by the description of nearby fibres as in Figure 5. We note that the degrees in the graph  $\overline{\mathcal{F}(f)_e}$  can be obtained by interchanging  $\mathcal{G}(f)_o$  with  $\mathcal{G}(f)_e$  in the table. In these tables, most upper row  $*_o$  denotes  $\overline{II^*(f)_o}$ .

The lemma of the classical graph theory *The handshake lemma* claims that in the finite graph the total number of degree through all vertices is equal to the double of the total number of all edges.

We apply this lemma to the graphs  $\overline{II^{0,0}(f)_o}$ ,  $\overline{II^{0,0}(f)_e}$ ,  $\overline{II^{0,1}(f)_o}$ ,  $\overline{II^{0,1}(f)_e}$ ,  $\overline{II^{1,1}(f)_o}$ ,  $\overline{II^{1,1}(f)_e}$ ,  $\overline{II^{0,2}(f)_o}$ ,  $\overline{II^{0,2}(f)_e}$ ,  $\overline{II^{1,2}(f)_o}$ ,  $\overline{II^{1,2}(f)_e}$ ,  $\overline{II^{2,2}(f)_o}$ ,  $\overline{II^{2,2}(f)_e}$ ,  $\overline{II^3(f)_o}$ ,  $\overline{II^3(f)_e}$ ,  $\overline{II^4(f)_o}$ ,  $\overline{II^4(f)_e}$ ,  $\overline{II^5(f)_o}$ ,  $\overline{II^5(f)_e}$ ,  $\overline{II^6(f)_o}$ ,  $\overline{II^6(f)_e}$ ,  $\overline{II^7(f)_o}$ ,  $\overline{II^7(f)_e}$ ,  $\overline{II^a(f)_o}$  and  $\overline{II^a(f)_e}$ . Then we obtain 23 co-existence

relations among the number of  $\kappa = 3$  singular fibres  $\mathcal{G}(f)_o$  and  $\mathcal{G}(f)_e$ . Then we eliminate the term of the forms  $|\mathcal{G}(f)_o|$  and  $|\mathcal{G}(f)_e|$ . Thus we obtain the following.

**Proposition 4.1** *Let  $f : M \rightarrow N$  be a stable map from a closed 4-manifold  $M$  to a 3-manifold  $N$ . Then the following numbers are always even.*

1.  $|\text{III}^{0,a}(f)| + |\text{III}^d(f)|$
2.  $|\text{III}^{0,a}(f)| + |\text{III}^{1,a}(f)| + |\text{III}^b(f)|$
3.  $|\text{III}^8(f)| + |\text{III}^{1,a}(f)|$
4.  $|\text{III}^{2,a}(f)| + |\text{III}^c(f)|$
5.  $|\text{III}^{2,a}(f)| + |\text{III}^{14}(f)|$
6.  $|\text{III}^{20}(f)|$
7.  $|\text{III}^8(f)| + |\text{III}^{11}(f)| + |\text{III}^{17}(f)| + |\text{III}^b(f)| + |\text{III}^f(f)|$
8.  $|\text{III}^{11}(f)| + |\text{III}^{13}(f)| + |\text{III}^{21}(f)| + |\text{III}^e(f)|$
9.  $|\text{III}^{17}(f)| + |\text{III}^{21}(f)| + |\text{III}^g(f)|$
10.  $|\text{III}^{14}(f)| + |\text{III}^c(f)|$
11.  $|\text{III}^{13}(f)| + |\text{III}^{20}(f)|$

It is easy to see that the 11 numbers appearing in Proposition 4.1 are all even if and only if the following arguments hold.

1.  $|\text{III}^{0,a}(f)| \equiv |\text{III}^d(f)| \pmod{2}$
2.  $|\text{III}^{1,a}(f)| \equiv |\text{III}^8(f)| \pmod{2}$
3.  $|\text{III}^{2,a}(f)| \equiv |\text{III}^c(f)| \equiv |\text{III}^{14}(f)| \pmod{2}$
4.  $|\text{III}^{13}(f)| \equiv 0 \equiv |\text{III}^{20}(f)| \pmod{2}$
5.  $|\text{III}^d(f)| + |\text{III}^e(f)| + |\text{III}^f(f)| + |\text{III}^g(f)| \equiv 0 \pmod{2}$
6.  $|\text{III}^{0,a}(f)| + |\text{III}^{1,a}(f)| + |\text{III}^b(f)| \equiv 0 \pmod{2}$

We note that the left hand side of congruence 6 is nothing but the total number of swallow-tail points. And the left hand side of congruence 3 and 6 imply that the total number of multi-germ of cusp and fold is always even.

We combine above 23 co-existence relations among singular fibres  $\mathcal{G}(f)_o$  and  $\mathcal{G}(f)_e$  well. Thus we obtain following co-existence formula.

$$\begin{aligned}
& |\text{III}^{0,0,0}(f)| + |\text{III}^{0,0,1}(f)| + |\text{III}^{0,1,1}(f)| + |\text{III}^{1,1,1}(f)| + |\text{III}^{0,2,2}(f)| + |\text{III}^{0,3}(f)| + |\text{III}^{0,4}(f)| \\
& + |\text{III}^{0,5}(f)| + |\text{III}^{0,7}(f)| + |\text{III}^{1,2,2}(f)| + |\text{III}^{1,3}(f)| + |\text{III}^{1,4}(f)| + |\text{III}^{1,5}(f)| + |\text{III}^{1,7}(f)| \\
& + |\text{III}^{2,6}(f)| + |\text{III}^8(f)| + |\text{III}^9(f)| + |\text{III}^{10}(f)| + |\text{III}^{11}(f)| + |\text{III}^{13}(f)| + |\text{III}^{15}(f)| \\
& + |\text{III}^{18}(f)| + |\text{III}^{19}(f)| + |\text{III}^{20}(f)| + |\text{III}^{21}(f)| + |\text{III}^d(f)_e| + |\text{III}^e(f)_e| + |\text{III}^f(f)_o| \\
& + |\text{III}^g(f)_o| \equiv 0 \pmod{2}
\end{aligned}$$

We call this formula (T), and we will use this relation in the next section.

	0,0o	0,1o	1,1o	0,2o	1,2o	2,2o	3o	4o	5o	6o	7o	ao
$\text{III}^{0,0,0}(f)_o$	3											
$\text{III}^{0,0,0}(f)_e$	3											
$\text{III}^{0,0,1}(f)_o$	1	2										
$\text{III}^{0,0,1}(f)_e$	1	2										
$\text{III}^{0,1,1}(f)_o$		2	1									
$\text{III}^{0,1,1}(f)_e$		2	1									
$\text{III}^{1,1,1}(f)_o$			3									
$\text{III}^{1,1,1}(f)_e$			3									
$\text{III}^{0,0,2}(f)_o$	2			2								
$\text{III}^{0,0,2}(f)_e$				2								
$\text{III}^{0,2,2}(f)_o$				4			1					
$\text{III}^{0,2,2}(f)_e$							1					
$\text{III}^{2,2,2}(f)_o$							6					
$\text{III}^{2,2,2}(f)_e$												
$\text{III}^{1,1,2}(f)_o$			2		2							
$\text{III}^{1,1,2}(f)_e$					2							
$\text{III}^{1,2,2}(f)_o$					4	1						
$\text{III}^{1,2,2}(f)_e$						1						
$\text{III}^{0,1,2}(f)_o$		2		1	1							
$\text{III}^{0,1,2}(f)_e$				1	1							
$\text{III}^{0,3}(f)_o$		2					1					
$\text{III}^{0,3}(f)_e$		2					1					
$\text{III}^{0,4}(f)_o$		4						1				
$\text{III}^{0,4}(f)_e$								1				
$\text{III}^{0,5}(f)_o$		2		2					1			
$\text{III}^{0,5}(f)_e$									1			
$\text{III}^{0,6}(f)_o$		2		1						1		
$\text{III}^{0,6}(f)_e$				1						1		
$\text{III}^{0,7}(f)_o$	2			4							1	
$\text{III}^{0,7}(f)_e$											1	
$\text{III}^{1,3}(f)_o$			2				1					
$\text{III}^{1,3}(f)_e$			2				1					
$\text{III}^{1,4}(f)_o$			4					1				
$\text{III}^{1,4}(f)_e$								1				
$\text{III}^{1,5}(f)_o$			2		2				1			
$\text{III}^{1,5}(f)_e$									1			
$\text{III}^{1,6}(f)_o$			2		1					1		
$\text{III}^{1,6}(f)_e$					1					1		
$\text{III}^{1,7}(f)_o$					4						1	
$\text{III}^{1,7}(f)_e$											1	
$\text{III}^{2,3}(f)_o$					2		2					
$\text{III}^{2,3}(f)_e$					2							
$\text{III}^{2,4}(f)_o$					4			2				
$\text{III}^{2,4}(f)_e$												
$\text{III}^{2,5}(f)_o$					2	2			2			
$\text{III}^{2,5}(f)_e$												
$\text{III}^{2,6}(f)_o$					2	1				2		

Table 1: Degree of each vertex in the graphs

	0,0o	0,1o	1,1o	0,2o	1,2o	2,2o	3o	4o	5o	6o	7o	ao
$\text{III}^{2,6}(f)_e$						1						
$\text{III}^{2,7}(f)_o$						4					2	
$\text{III}^{2,7}(f)_e$												
$\text{III}^{0,a}(f)_o$		1										1
$\text{III}^{0,a}(f)_e$	1											1
$\text{III}^{1,a}(f)_o$			1									1
$\text{III}^{1,a}(f)_e$		1										1
$\text{III}^{2,a}(f)_o$					1							2
$\text{III}^{2,a}(f)_e$				1								
$\text{III}^8(f)_o$							3					
$\text{III}^8(f)_e$			1				2					
$\text{III}^9(f)_o$							3					
$\text{III}^9(f)_e$							3					
$\text{III}^{10}(f)_o$							4	1				
$\text{III}^{10}(f)_e$								1				
$\text{III}^{11}(f)_o$							3	3				
$\text{III}^{11}(f)_e$												
$\text{III}^{12}(f)_o$								6				
$\text{III}^{12}(f)_e$												
$\text{III}^{13}(f)_o$								1	4		1	
$\text{III}^{13}(f)_e$												
$\text{III}^{14}(f)_o$					1		2			2		
$\text{III}^{14}(f)_e$										1		
$\text{III}^{15}(f)_o$		2	1				2		1	2		
$\text{III}^{15}(f)_e$									1			
$\text{III}^{16}(f)_o$									2	2	2	
$\text{III}^{16}(f)_e$												
$\text{III}^{17}(f)_o$							3		3			
$\text{III}^{17}(f)_e$												
$\text{III}^{18}(f)_o$										4	1	
$\text{III}^{18}(f)_e$											1	
$\text{III}^{19}(f)_o$										4	1	
$\text{III}^{19}(f)_e$											1	
$\text{III}^{20}(f)_o$										4	1	
$\text{III}^{20}(f)_e$						1						
$\text{III}^{21}(f)_o$								1	3	2		
$\text{III}^{21}(f)_e$												
$\text{III}^{22}(f)_o$								2		4		
$\text{III}^{22}(f)_e$												
$\text{III}^{23}(f)_o$							2			2		
$\text{III}^{23}(f)_e$										2		
$\text{III}^{24}(f)_o$							2			2		
$\text{III}^{24}(f)_e$										2		
$\text{III}^{25}(f)_o$											6	
$\text{III}^{25}(f)_e$												
$\text{III}^{26}(f)_o$											6	
$\text{III}^{26}(f)_e$												

Table 2: Degree of each vertex in the graphs

	0, 0o	0, 1o	1, 1o	0, 2o	1, 2o	2, 2o	3o	4o	5o	6o	7o	ao
$\text{III}^b(f)_o$							1					1
$\text{III}^b(f)_e$		1										1
$\text{III}^c(f)_o$										1		2
$\text{III}^c(f)_e$				1								
$\text{III}^d(f)_o$												2
$\text{III}^d(f)_e$	1											
$\text{III}^e(f)_o$								1				2
$\text{III}^e(f)_e$												
$\text{III}^f(f)_o$							1					
$\text{III}^f(f)_e$												2
$\text{III}^g(f)_o$									1			2
$\text{III}^g(f)_e$												

Table 3: Degree of each vertex in the graphs

## 5 Parity of the Euler characteristic

In this section we study the relation between the total number of specified singular fibres and Euler characteristic of the source 4-manifold, based on the co-existence results among singular fibres obtained in the previous section.

Let  $f : M \rightarrow N$  be a stable map from a closed 4-manifold to a 3-manifold, we recall that we obtained the stratification of  $N$  in the previous section. We can further subdivide this stratification in the following way. We define  $\mathcal{O}_n(f)$  be the set of points in  $N \setminus f(S(f))$  such that the number of connected components of the fibre is  $n$ . Then we obtain second stratification of  $N$ . This stratification consist of  $\mathcal{F}(f)$  and  $\mathcal{O}_n(f)$  where  $\mathcal{F}$  runs all of  $C^\infty$  equivalence class of singular fibres in Figure 6, 7 and  $n$  runs all of natural numbers. Thus the set of regular values  $N \setminus f(S(f))$  consists of 3-strata  $\mathcal{O}_n(f)$  ( $n = 0, 1, 2, \dots$ ) while the set of singular values  $f(S(f))$  consists of 2, 1 and 0 strata. Throughout this section, stratification means this stratification of  $N$ , not that of §4. Then we assign each 3-stratum the number of connected components of fibre. We replace the *Number of Connected Components of the Fibre* with the *NCCF*.

Let  $X$  be a 2 dimensional simplicial complex embedded in a connected 3-manifold  $Y$ . We say  $Y \setminus X$  has two color decomposition if there exist non-empty disjoint open subset  $R, B$  of  $Y$  such that  $Y \setminus X = R \cup B$  and  $\partial R = \partial B = X$ . We call a pair  $(R, B)$  *two color decomposition* for  $Y \setminus X$  if  $R$  and  $B$  satisfied the above condition. In the following we study when  $N \setminus f(S(f))$  has two color decomposition for a stable map  $f : M^4 \rightarrow N^3$  from a closed 4-manifold  $M$  to a connected 3-manifold  $N$ .

Let  $f : M^4 \rightarrow N^3$  be as above, and we define  $\Delta(f)_o$  (resp.  $\Delta(f)_e$ ) be the set of points in  $N \setminus f(S(f))$  such that the NCCF is odd (resp. even). Then  $\Delta(f)_o$  and  $\Delta(f)_e$  are the union of 3-strata of the above stratification. It is easy to see that they are disjoint open subsets of  $N$ . Furthermore, the closure  $\overline{\Delta(f)_o}$  (resp.  $\overline{\Delta(f)_e}$ ) of  $\Delta(f)_o$  (resp.  $\Delta(f)_e$ ) is compact since  $M$  is compact. If  $M$  is orientable then we have

$$\overline{\Delta(f)_o} \cap \overline{\Delta(f)_e} = \partial \Delta(f)_o = \partial \Delta(f)_e = f(S(f)),$$

since the difference of the NCCF of two 3-strata which adjoint each other is always one. (Where “two 3-strata adjoint each other” means that the closure of these strata contain 2-stratum as a part of common boundary.) Namely if  $M$  is orientable then the pair  $(\Delta(f)_o, \Delta(f)_e)$  is two color

decomposition for  $N \setminus f(S(f))$ . But if  $M$  is non-orientable then the NCCF of adjoined two 3-strata might be same. In fact if  $S \subset f(S(f))$  is a 2 dimensional object whose corresponding fibre is  $I^2$  type then the NCCF of two 3-strata which are adjacent to  $S$  is same, Figure 9. And if  $M$  is non-orientable,  $I^2$  type fibre always appear. Hence, we have

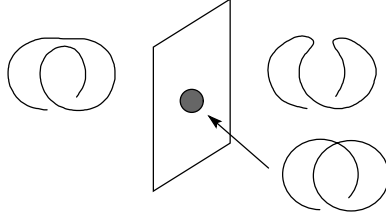

Figure 9: Degeneration of  $I^2$  type fibre

$$\overline{\Delta(f)_o} \cap \overline{\Delta(f)_e} = \partial\Delta(f)_o = \partial\Delta(f)_e \neq f(S(f)).$$

Thus if  $M$  is non-orientable then the pair  $(\Delta(f)_o, \Delta(f)_e)$  never be two color decomposition for  $N \setminus f(S(f))$ . Next Lemma claims that  $N \setminus f(S(f))$  has two color decomposition under suitable condition .

**Lemma 5.1 (J.J. Nuño Ballesteros-O. Saeki)** *Let  $g : X \rightarrow Y$  be a stable map from a closed 2-manifold  $X$  to a connected 3-manifold  $Y$  such that either  $H_1(Y, \mathbb{Z}_2) = 0$  or  $g_*[X] = 0 \in H_2(Y, \mathbb{Z}_2)$ . Then  $Y \setminus g(X)$  has two color decomposition pair  $(R, B)$ .*

We note that the map  $f|_{S(f)} : S(f) \rightarrow N$  is a topologically stable surface, where  $f : M \rightarrow N$  is as above. The smooth surface  $g : X^2 \rightarrow Y^3$  is topologically stable surface when there exists  $C^\infty$  stable surface  $\tilde{g} : \tilde{X}^2 \rightarrow \tilde{Y}^3$ , and homeomorphism  $\phi : X \rightarrow \tilde{X}$ ,  $\psi : Y \rightarrow \tilde{Y}$  such that  $\psi \circ g = \tilde{g} \circ \phi$ . We note that Lemma 5.1 is useful for topological stable surface. Thus we can apply this Lemma to  $f|_{S(f)}$ . For a stable map  $f : M \rightarrow N$  which is as above, if we assume that  $f|_{S(f)} : S(f) \rightarrow N$  satisfied  $f_*[S(f)] = 0 \in H^2(N, \mathbb{Z}_2)$  or  $H^1(N, \mathbb{Z}_2) = 0$  then there exists two color decomposition pair  $(R, B)$  for  $N \setminus f(S(f))$ . In the following we call the assumption that  $g : X^2 \rightarrow Y^3$  satisfies either  $H_1(Y, \mathbb{Z}_2) = 0$  or  $g_*[X] = 0 \in H_2(Y, \mathbb{Z}_2)$ , *two colorable condition*.

Next theorem is very important tool to connect our singular fibres and topology of source manifold.

**Theorem 5.2 (J.J. Nuño Ballesteros-O. Saeki)** *Let  $g : X \rightarrow Y$  be a stable map from a closed 2-manifold  $X$  to a connected 3-manifold  $Y$  such that  $g$  satisfies two colorable condition. Then we have;*

$$T(g) + \sum_{q:\text{whitney umbrella}} n(q, g) \equiv \chi(X),$$

where  $T(g)$  is total number of triple point of  $f$ , and  $n(q, g)$  is the index of Whitney umbrella point  $q$  conveniently defined by around two color decomposition of  $q$  as Figure 10.

The swallow-tail point of  $f$  is correspond to a Whitney umbrella point of  $f|_{S(f)}$ , and Theorem 5.2 is also useful for topologically stable surface.

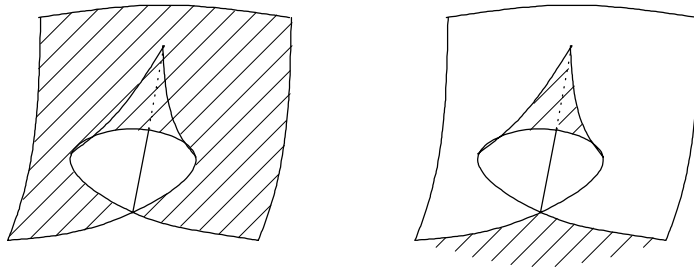

Figure 10: Left hand side is indexed by 1, and right is 0

On the other hands, if we assign no condition for  $f : M^4 \rightarrow N^3$  then we do not know how indexed to Whitney umbrella point of  $f|_{S(f)}$ . However if  $f : M \rightarrow \mathbb{R}^3$  is a stable map from a closed 4-manifold to  $\mathbb{R}^3$  which has no swallow-tail points then we see that

$$T(f) \equiv \chi(S(f)) \pmod{2},$$

by Theorem 5.2 or Banchoff result; For any (generic) immersion  $f : X^2 \rightarrow \mathbb{R}^3$  from closed surface  $X^2$  to  $\mathbb{R}^3$  the number of triple points of immersion  $f$  and Euler characteristic of the surface  $X^2$  are of the same parity.

We combine the co-existence of singular fibres (T), acquired in section 4, and this Banchoff result. Then we obtain,

$$\begin{aligned} & |III^{0,0,2}(f)| + |III^{0,6}(f)| + |III^{1,1,2}(f)| + |III^{1,6}(f)| + |III^{0,1,2}(f)| + |III^{2,2,2}(f)| + |III^{2,3}(f)| + |III^{2,4}(f)| \\ & + |III^{2,5}(f)| + |III^{2,7}(f)| + |III^{12}(f)| + |III^{14}(f)| + |III^{16}(f)| + |III^{17}(f)| + |III^{22}(f)| + |III^{23}(f)| \\ & + |III^{24}(f)| + |III^{25}(f)| + |III^{26}(f)| \equiv \chi(S(f)) \pmod{2}. \end{aligned}$$

On the other hand we have,

**Theorem 5.3 (T.Fukuda, O.Saeki)** *Let  $h : V \rightarrow N$  be a stable map from a closed  $n$ -manifold  $V$  to a 3-manifold  $N$ . Then we have*

$$\chi(V) \equiv \chi(S(h)) \pmod{2}.$$

Thus we obtain the following proposition.

**Proposition 5.4** *Let  $f : M \rightarrow \mathbb{R}^3$  be a stable map from 4-manifold to  $\mathbb{R}^3$  which has no swallow tail points. Then we have*

$$\begin{aligned} \chi(M) \equiv & |III^{0,0,2}(f)| + |III^{1,1,2}(f)| + |III^{2,2,2}(f)| + |III^{0,1,2}(f)| + |III^{0,6}(f)| \\ & + |III^{1,6}(f)| + |III^{2,3}(f)| + |III^{2,4}(f)| + |III^{2,5}(f)| + |III^{2,7}(f)| \\ & + |III^{12}(f)| + |III^{14}(f)| + |III^{16}(f)| + |III^{17}(f)| + |III^{22}(f)| \\ & + |III^{23}(f)| + |III^{24}(f)| + |III^{25}(f)| + |III^{26}(f)| \pmod{2}. \end{aligned}$$

Secondly we consider a stable map  $f : M \rightarrow N$  from a closed 4-manifold  $M$  to a connected 3-manifold  $N$ , and suppose  $f|_{S(f)}$  satisfies two colorable condition. Then, based on two color decomposition  $(R, B)$  for  $N \setminus f(S(f))$ , we divide several singular fibres of  $\kappa = 1, 2, 3$  into two

types  $A, B$ . At first, for any class  $\mathcal{E}$  of  $\kappa = 1$ ,  $\mathcal{E}(f)$  is defined in §4,  $\mathcal{E}(f)$  is adjacent to two 3-strata. If  $\mathcal{E}$  is  $I^0$  or  $I^1$  then the difference of the NCCF of the two 3-strata which are adjacent to  $\mathcal{E}(f)$  is always one. (Where “ $\mathcal{F}(f)$  adjacent to  $n$  3-strata” means that for any point  $q$  in  $\mathcal{F}(f)$  and any sufficiently small open neighborhood  $U$  of  $q$  in  $N$ ,  $U$  intersects  $n$  3-strata.) Thus if the 3-strata whose corresponding number is higher is colored by  $R$  then we define corresponding singular fibre is  $I_A^*$ , otherwise  $I_B^*$  (here  $*$  = 0 or 1). If  $\mathcal{E}$  is  $I^2$  then the difference of the NCCF of the two 3-strata which are adjacent to  $\mathcal{E}(f)$  is always zero; Figure 9. We can not divide  $I^2$  types into type  $A$  and  $B$ . In next, for any equivalence class  $\mathcal{F}$  of  $\kappa = 2$ , except for  $II^a$ ,  $\mathcal{F}(f)$  is adjacent to four 3-strata. Now we combine the NCCF and the color for each 3-strata which are adjacent to  $\mathcal{F}(f)$ . Then we can divide 2 types  $A$  or  $B$  as following way. If the NCCF of two red parts are differ (resp. same) then we define corresponding singular fibre is  $II_A^*$  (resp.  $II_B^*$ ), Figure 11, 12. In this way we see  $II^{0,0}(f)$ ,  $II^{0,1}(f)$ ,  $II^{1,1}(f)$ ,  $II^3(f)$ ,  $II^4(f)$ , and  $II^5(f)$  have two types  $A$  and  $B$ . But  $II^{0,2}$ ,  $II^{1,2}$ ,  $II^{2,2}$ ,  $II^6$ ,  $II^7$  don not divide into 2 type, Figure 13. As same way as  $I^0$  or  $I^1$ , the singular fibre of  $II^a$  type has 2 types  $A$  and  $B$ .

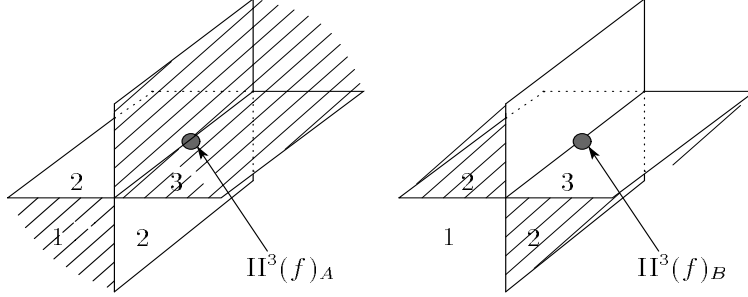

Figure 11: Type  $A, B$  of  $II^3$

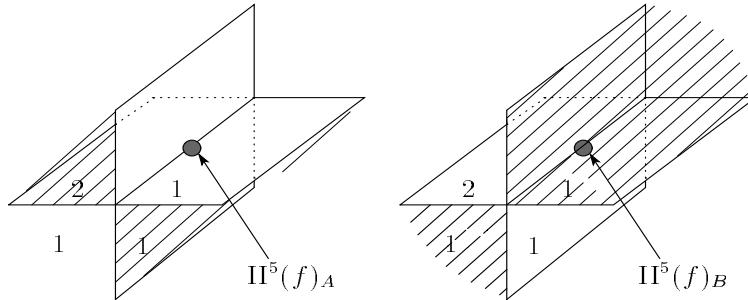

Figure 12: Type  $A, B$  of  $II^5$

In Figure 11, 12, 13, 14, 15 and 16, we note that some number in 3-strata is the NCCF of each 3-strata, when the centered singular value has no circle in its fibre.

In last  $\kappa = 3$  we see  $III^{0,0,0}(f)$ ,  $III^{0,0,1}(f)$ ,  $III^{0,1,1}(f)$ ,  $III^{1,1,1}(f)$ ,  $III^{0,3}(f)$ ,  $III^{0,4}(f)$ ,  $III^{0,5}$ ,  $III^{1,3}(f)$ ,  $III^{1,4}(f)$ ,  $III^{1,5}(f)$ ,  $III^8(f)$ ,  $III^9(f)$ ,  $III^{10}(f)$ ,  $III^{11}(f)$ ,  $III^{12}(f)$ ,  $III^{13}(f)$ ,  $III^{15}(f)$ ,  $III^{17}(f)$ ,  $III^{21}(f)$ ,  $III^{0,a}(f)$ ,  $III^{1,a}(f)$ ,  $III^b(f)$ ,  $III^d(f)$ ,  $III^e(f)$ ,  $III^f(f)$  and  $III^g(f)$  have type  $A, B$ , by the similar way as  $\kappa = 2$ ; Figure 14, 15, and 16. The singular fibre of other types do not have type  $A, B$ .

Let  $f : M^4 \rightarrow N^3$  be as above and  $f|_{S(f)}$  satisfy two color condition. And let  $\mathcal{F}$  be the equivalence class of one of the singular fibres appearing in Figure 6 of  $\kappa = 2$ . If  $\mathcal{F}$  has types



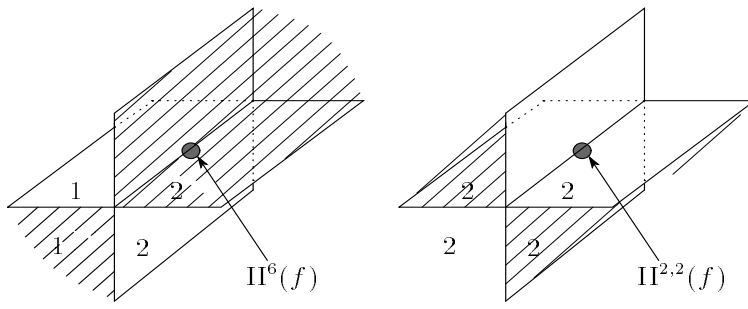

Figure 13: These type have only one type

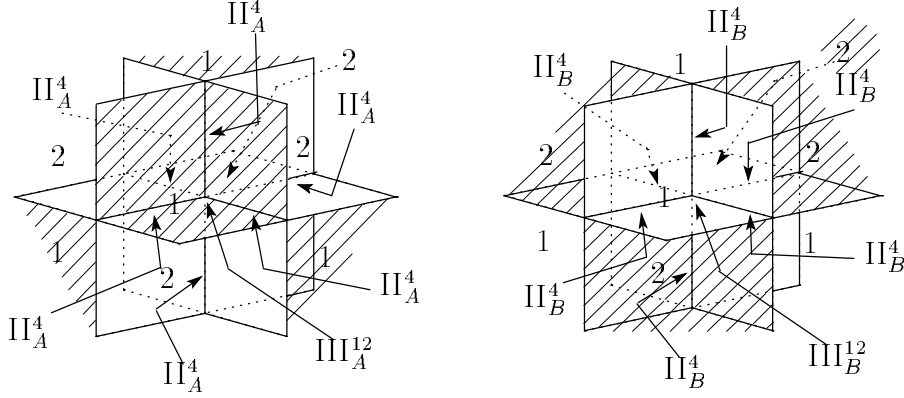

Figure 14: Type  $A, B$  of  $\text{III}^{12}$

$A, B$  then we define  $\mathcal{F}(f)_A$  (resp.  $\mathcal{F}(f)_B$ ) be the set of points  $q \in \mathcal{F}(f)$  such that around  $q$  colored as  $A$ -type (resp.  $B$ -type). If  $\mathcal{F}$  do not have type  $A, B$  then we consider just  $\mathcal{F}(f)$ . Then  $\mathcal{F}(f)_A, \mathcal{F}(f)_B$  and  $\mathcal{F}(f)$  are finite graphs embedded in  $N$ . Their vertices correspond to points over which lies a singular fibre with  $\kappa = 3$ .

We again apply classical graph theory lemma to the graphs  $\overline{\Pi^{0,0}(f)_A}, \overline{\Pi^{0,0}(f)_B}, \overline{\Pi^{0,1}(f)_A}, \overline{\Pi^{0,1}(f)_B}, \overline{\Pi^{1,1}(f)_A}, \overline{\Pi^{1,1}(f)_B}, \overline{\Pi^{0,2}(f)}, \overline{\Pi^{1,2}(f)}, \overline{\Pi^{2,2}(f)}, \overline{\Pi^3(f)_A}, \overline{\Pi^3(f)_B}, \overline{\Pi^4(f)_A}, \overline{\Pi^4(f)_B}, \overline{\Pi^5(f)_A}, \overline{\Pi^5(f)_B}, \overline{\Pi^6(f)}, \overline{\Pi^7(f)}, \overline{\Pi^a(f)_A}$  and  $\overline{\Pi^a(f)_B}$ . Then we obtain 18-th co-existence relation among singular fibres.

**Proposition 5.5** *Let  $f : M \rightarrow N$  be a stable map from a closed 4-manifold  $M$  to a connected 3-manifold  $N$ . Suppose  $f|_{S(f)}$  satisfied two color condition. Then the following numbers are always even;*

1.  $|\text{III}^{0,0,0}(f)| + |\text{III}^{0,0,1}(f)| + |\text{III}^{0,0,2}(f)| + |\text{III}^{0,a}(f)_A| + |\text{III}^d(f)_A|$
2.  $|\text{III}^{0,0,0}(f)| + |\text{III}^{0,0,1}(f)| + |\text{III}^{0,0,2}(f)| + |\text{III}^{0,a}(f)_B| + |\text{III}^d(f)_B|$
3.  $|\text{III}^{0,a}(f)_A| + |\text{III}^{1,a}(f)_A| + |\text{III}^b(f)_A| + |\text{III}^{0,6}(f)| + |\text{III}^{0,1,2}(f)|$

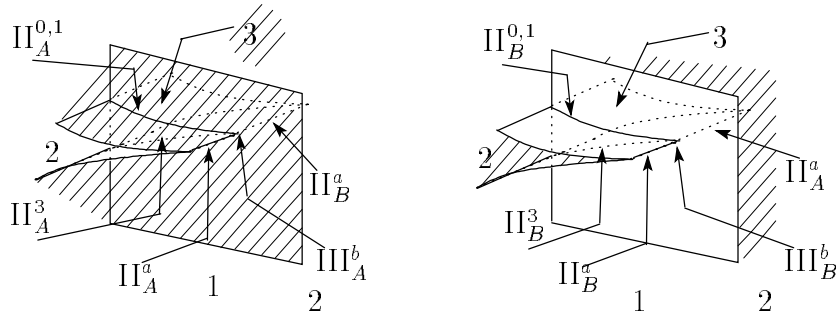

Figure 15: Type A, B of  $\text{III}^b$

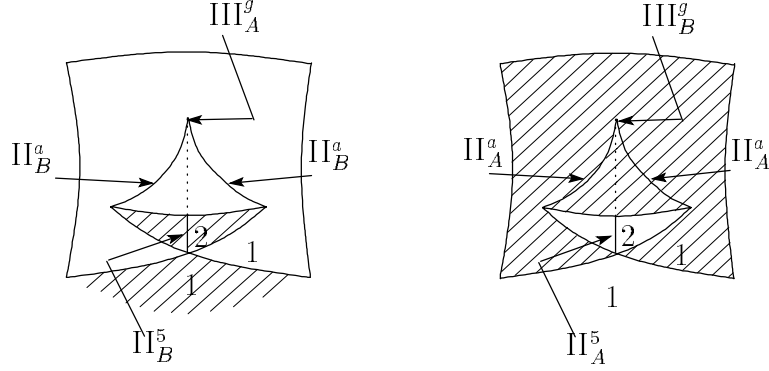

Figure 16: Type A, B of  $\text{III}^g$

4.  $|\text{III}^{0,a}(f)_B| + |\text{III}^{1,a}(f)_B| + |\text{III}^b(f)_B| + |\text{III}^{0,6}(f)| + |\text{III}^{0,1,2}(f)|$
5.  $|\text{III}^{1,1,1}(f)| + |\text{III}^{0,1,1}(f)| + |\text{III}^{1,1,2}(f)| + |\text{III}^{1,6}(f)| + |\text{III}^8(f)_B| + |\text{III}^{1,a}(f)_A|$
6.  $|\text{III}^{1,1,1}(f)| + |\text{III}^{0,1,1}(f)| + |\text{III}^{1,1,2}(f)| + |\text{III}^{1,6}(f)| + |\text{III}^8(f)_A| + |\text{III}^{1,a}(f)_B|$
7.  $|\text{III}^{2,a}(f)| + |\text{III}^c(f)|$
8.  $|\text{III}^{14}(f)| + |\text{III}^{2,a}(f)|$
9.  $|\text{III}^{20}(f)|$
10.  $|\text{III}^{0,3}(f)| + |\text{III}^{1,3}(f)| + |\text{III}^{2,3}(f)| + |\text{III}^8(f)_A| + |\text{III}^9(f)| + |\text{III}^{11}(f)_A| + |\text{III}^{14}(f)| + |\text{III}^{17}(f)_A| + |\text{III}^{23}(f)| + |\text{III}^{24}(f)| + |\text{III}^b(f)_A| + |\text{III}^f(f)_A|$
11.  $|\text{III}^{0,3}(f)| + |\text{III}^{1,3}(f)| + |\text{III}^{2,3}(f)| + |\text{III}^8(f)_B| + |\text{III}^9(f)| + |\text{III}^{11}(f)_B| + |\text{III}^{14}(f)| + |\text{III}^{17}(f)_B| + |\text{III}^{23}(f)| + |\text{III}^{24}(f)| + |\text{III}^b(f)_B| + |\text{III}^f(f)_B|$

12.  $|III^{0,4}(f)| + |III^{1,4}(f)| + |III^{2,4}(f)| + |III^{10}(f)| + |III^{11}(f)_A| + |III^{13}(f)_B| + |III^{21}(f)_A| + |III^{22}(f)| + |III^e(f)_B|$
13.  $|III^{0,4}(f)| + |III^{1,4}(f)| + |III^{2,4}(f)| + |III^{10}(f)| + |III^{11}(f)_B| + |III^{13}(f)_A| + |III^{21}(f)_B| + |III^{22}(f)| + |III^e(f)_A|$
14.  $|III^{0,5}(f)| + |III^{1,5}(f)| + |III^{2,5}(f)| + |III^{15}(f)| + |III^{16}(f)| + |III^{17}(f)_A| + |III^{21}(f)_B| + |III^g(f)_B|$
15.  $|III^{0,5}(f)| + |III^{1,5}(f)| + |III^{2,5}(f)| + |III^{15}(f)| + |III^{16}(f)| + |III^{17}(f)_B| + |III^{21}(f)_A| + |III^g(f)_A|$
16.  $|III^{14}(f)| + |III^c(f)|$
17.  $|III^{13}(f)| + |III^{20}(f)|$
18.  $|III^{0,a}(f)| + |III^{1,a}(f)| + |III^b(f)|$

We eliminate the terms of the forms  $|III^*(f)_A|$  and  $|III^*(f)_B|$  in previous modulo 2 relations. Then we obtain the completely same co-existence relation of singular fibres as Proposition 4.1.

We add the items (1), (3), (5), (9), (10), (13), and (15) of Proposition 5.5, then we obtain

$$\begin{aligned}
& |III^{0,0,0}(f)| + |III^{0,0,1}(f)| + |III^{0,0,2}(f)| + |III^{0,1,1}(f)| + |III^{1,1,1}(f)| + |III^{0,1,2}(f)| + |III^{1,1,2}(f)| \\
& + |III^{0,3}(f)| + |III^{0,4}(f)| + |III^{0,5}(f)| + |III^{0,6}(f)| + |III^{1,3}(f)| + |III^{1,4}(f)| + |III^{1,5}(f)| \\
& + |III^{1,6}(f)| + |III^{2,3}(f)| + |III^{2,4}(f)| + |III^{2,5}(f)| + |III^8(f)| + |III^9(f)| + |III^{10}(f)| \\
& + |III^{11}(f)| + |III^{14}(f)| + |III^{15}(f)| + |III^{16}(f)| + |III^{17}(f)| + |III^{20}(f)| + |III^{21}(f)| \\
& + |III^{22}(f)| + |III^{23}(f)| + |III^{24}(f)| + |III^{13}(f)_A| + |III^d(f)_A| + |III^e(f)_A| + |III^f(f)_A| \\
& + |III^g(f)_A| \equiv 0 \pmod{2}.
\end{aligned}$$

We call this relation (S).

We recall that Theorem 4.2 claims that

$$\chi(S(f)) \equiv T(f) + \sum_{q:\text{whitney umbrella}} \text{ind}(q; f) \pmod{2}.$$

We add (S) to right hand side of above formula, then we obtain

$$\begin{aligned}
\chi(S(f)) & \equiv |III^{0,2,2}(f)| + |III^{1,2,2}(f)| + |III^{2,2,2}(f)| + |III^{0,7}(f)| + |III^{1,7}(f)| \\
& + |III^{2,6}(f)| + |III^{2,7}(f)| + |III^{12}(f)| + |III^{18}(f)| + |III^{19}(f)| \\
& + |III^{25}(f)| + |III^{26}(f)| + |III_A^{13}(f)| + |III_A^d(f)| + |III_A^e(f)| \\
& + |III_A^f(f)| + |III_A^g(f)| + \sum \text{ind}(q; f) \pmod{2}.
\end{aligned}$$

Finally, we recall that

$$\sum_{q:\text{whitney umbrella}} \text{ind}(q; f) = |\text{III}^d(f)_A| + |\text{III}^e(f)_A| + |\text{III}^f(f)_A| + |\text{III}^g(f)_A|,$$

and Theorem 5.3 then we obtain our Theorem 1.1.

## References

- [1] T. Fukuda, *Topology of folds, cusps and Morin singularities*, in “A Fete of Topology”, eds. Y. Matsumoto, T. Mizutani and S. Morita, Academic Press, 1987, pp.331–353.
- [2] C. G. Gibson, *Singular points of smooth mappings*, Pitman, London 1979.
- [3] C. G. Gibson, K. Wirthmüller, A. A. du Plessis, E. J. N. Looijenga, *Topological Stability of Smooth Mappings* Lect. Notes. in Math. 552, Springer, Berlin 1976.
- [4] M. Golubitsky and V. Guillemin, *Stable mappings and their singularities*, Grad. Texts in Math. 14, Springer, New York, Heidelberg, Berlin, 1973.
- [5] M. Kobayashi, *Two nice stable maps of  $\mathbb{C}^2P$  into  $\mathbb{R}^3$* , Sūrikaisekikenkyūsho Kōkyūroku 926 Geometric aspects of real singularities (Japanese) 73–81.
- [6] L. Kushner, H. Levine, and P. Porto, *Mapping three manifold into the plane*, Bol. Soc. Mat. Mex. vol. 29 no. 1 (1984) 11–34.
- [7] H. Levine, *Elimination of cusps*, Topology 3 (suppl.2). 1965. 263–296.
- [8] H. Levine, *Classifying Immersions into  $\mathbb{R}^4$  over Stable Maps of 3-Manifolds into  $\mathbb{R}^2$* , Lect. Notes in Math. 1157, Springer, Berlin, 1985.
- [9] J. Martinet, *Singularities of Smooth Functions and Maps*, London Mathematical Society, Lecture Note Series 58 1982.
- [10] J. N. Mather, *Stability of  $\mathbb{C}^\infty$  mapping: VI, the nice dimension*, Lect. Notes in Math. 192, Springer, 1971, pp.207–253.
- [11] J. J. Nuño Ballesteros and O. Saeki, *On the number of singularities of a generic surface with boundary in a 3-manifold*, Hokkaido Math. J. 27 (1998), 517–544.
- [12] O. Saeki, *Note on the topology of folds*, J.Math. Soc. Japan 44 (1992), 551–544.
- [13] O. Saeki, *Studying the topology of Morin singularities from a global viewpoint*, Math. Proc. Camb. Phil. Soc. 117 (1995), 617–633.
- [14] O. Saeki, *Topology of singular fibres of generic maps*, preprint
- [15] A. Szücs, *Surface in  $\mathbb{R}^3$* , Bull. London Mrth. Soc. 18 (1986), 60–66.