

JUNE 2008

ISSN 1675-7009

# SCIENTIFIC RESEARCH JOURNAL



# SCIENTIFIC RESEARCH JOURNAL

## Chief Editor

Prof. Dr. Zaiki Awang,  
Universiti Teknologi MARA, Malaysia

## Managing Editor

Assoc. Prof. Dr. Razidah Ismail,  
Universiti Teknologi MARA, Malaysia

## Editorial Advisory and Review Board

Prof. Dr. Ir. Wahyu Kuntjoro, Universiti Teknologi MARA, Malaysia  
Assoc. Prof. Dr. Salmiah Kasolang, Universiti Teknologi MARA, Malaysia  
Assoc. Prof. Ir. Dr. Muhammad Azmi Ayub, Universiti Teknologi MARA, Malaysia  
Prof. Dr. Ichsan Setya Putra, Bandung Institute of Technology, Indonesia  
Prof. Dr. Mohd. Nasir Taib, Universiti Teknologi MARA, Malaysia  
Prof. Dr. Ir. Shah Rizam Mohd. Shah Baki, Universiti Teknologi MARA, Malaysia  
Prof. Dr. Titik Khawa Abd. Rahman, Universiti Teknologi MARA, Malaysia  
Prof. Dr. Luciano Boglione, University of Massachusetts Lowell, USA  
Prof. Dr. K. Ito, Chiba University, Japan  
Prof. Dr. Azni Zain Ahmed, Universiti Teknologi MARA, Malaysia  
Prof. Ir. Dr. Ideris Zakaria, Universiti Malaysia Pahang, Malaysia  
Prof. Dr. Abd. Aziz Dato' Abd. Samad, Universiti Tun Hussein Onn, Malaysia  
Prof. Sr. Ir. Dr. Suhaimi Abd. Talib, Universiti Teknologi MARA, Malaysia  
Assoc. Prof. Ir. Dr. Kartini Kamaruddin, Universiti Teknologi MARA, Malaysia  
Assoc. Prof. Dr. Hamidah Mohd. Saman, Universiti Teknologi MARA, Malaysia  
Dr. Robert Michael Savory, Universiti Teknologi MARA, Malaysia  
Assoc. Prof. Dr. Mohd Hanapiah Abidin, Universiti Teknologi MARA, Malaysia

Copyright © 2008 Universiti Teknologi MARA, 40450 Shah Alam, Selangor, Malaysia.

All rights reserved. No part of this publication may be reproduced, stored in a retrieval system or transmitted in any form or by any means; electronics, mechanical, photocopying, recording or otherwise; without prior permission in writing from the Publisher.

*Scientific Research Journal is jointly published by Research Management Institute (RMI) and University Publication Centre (UPENA), Universiti Teknologi MARA, 40450 Shah Alam, Selangor, Malaysia.*

*The views and opinion expressed therein are those of the individual authors and the publication of these statements in the Scientific Research Journal do not imply endorsement by the publisher or the editorial staff. Copyright is vested in Universiti Teknologi MARA. Written permission is required to reproduce any part of this publication.*

# SCIENTIFIC RESEARCH JOURNAL

---

Vol. 5 No. 1

June 2008

ISSN 1675-7009

---

1. Bending Behaviour of Dowelled Mortise and Tenon Joints  
in Kempas 1  
*Rohana Hassan*  
*Azmi Ibrahim*  
*Zakiah Ahmad*
  
2. Properties of Ternary Blended Cement Containing Metakaolin  
and Fly Ash 13  
*Mohd Fadzil Arshad*  
*Megat Azmi Megat Johari*  
*Muhd Nurhasri Mohd Sidek*  
*Mazlee Mohd Noor*
  
3. Fatigue Life Monitoring Program of RMAF MiG-29 27  
*Wahyu Kuntjoro*  
*Ibrahim Bahari*  
*Abdul Ghani Ujang*  
*Assanah M Mydin*
  
4. Assessment of Soil Dispersibility Behaviour In-Relation to  
Soil Internal Erosion Resistance 39  
*Fauzilah Ismail*  
*Mazidah Mukri*  
*Zainab Mohamed*
  
5. Consensus and Source Properties of Malaysian Aggregates  
for Superior Performing Asphalt Pavements 53  
*Juraidah Ahmad*  
*Mohd Yusof Abdul Rahman*  
*Zainab Mohamed*

# Bending Behaviour of Dowelled Mortise and Tenon Joints in Kempas

Rohana Hassan<sup>1</sup>, Azmi Ibrahim & Zakiah Ahmad

*Institute for Infrastructure Engineering and Sustainable Management (IIESM)  
Faculty of Civil Engineering  
Universiti Teknologi MARA (UiTM), Malaysia  
<sup>1</sup>Email: rohan742@salam.uitm.edu.my*

## ABSTRACT

*Mortise and tenon are commonly used as timber connections between beam and column with enhancement by pultruded dowel. At present the data on the performance of mortise and tenon joints manufactured using Malaysian tropical timber is not available. Therefore there is a need to provide such data for better guidance and references in design purposes. This study investigates the behavior and strength properties of dowelled mortise and tenon timber connections using selected Malaysian tropical timber with different types of dowels namely steel and timber. Bending tests were performed on mortise and tenon beam-column joints of Kempas when plugged with steel or wood dowel. It is found that pegging the connections with the respective steel and timber dowels resulted in a bending load capacity of 6.09 and 5.32 kN, taken as the average of three samples, the latter being 12 % lower than former. Visual observation of the failed test pieces revealed steel dowels exhibiting yield mode  $I_m$  and wood, mode  $III_s$ . The wood dowels yielded in bending at one plastic hinge point per shear plane with an associated wood crushing while the steel dowels remained practically undeformed with an associated crushing of the main member.*

**Keywords:** *Bending, Dowelled joint, Mortise and tenon, Timber connection, Yield mode*

## **Introduction**

Mortise and tenon are the most common type of connection for jointing the beam and column member in timber frame structures. This connection is also one of the typical connections applied in the recent building construction system that is industrial building system (IBS). The basic mortise and tenon comprises of a tongue (tenon) cut into one rail and a mortise cut through the other rail.

The load carrying behavior of timber joints made with Malaysian tropical timber with regard to rigidity, load capacity and ductility are not well documented. The design of timber joint using steel connectors is given in MS 544: Part 5 [1], however the design code for traditional structural connection such as mortise and tenon are not available. On the other hand, the current European Yield Model (EYM) is also developed according to the double shear strength mechanical behavior which is not the true mortise and tenon joint. Thus, the true mechanical behavior of mortise and tenon joints are largely yet to cover.

Concerns of structural timber-frame particularly in mortise and tenon studies started prior to the publication of a dissertation by Brungraber [2]. He studied the mortise and tenon using wood dowel as an individual joint, together with full-scale frame testing, finite element analysis of joint behavior and a computer model that incorporated connection behavior. Erikson [3] commented that in continuation to Brungraber's work, the researchers from Germany, Kessel and Augustin reported that the oak dowel has sufficient strength for use in modern wood construction. Investigation of structural performance of timber pegged mortise and tenon joints and timber frame structures to develop methods for analyzing their strength and stiffness were then explored by few researchers such as Bulliet *et al.* [4], Sandberg *et al.* [5], Erikson [3], Miller [6], Shank and Walker [7] and Walker *et al.* [8].

Present design codes or codes of practice of timber that is the BS 5268 [9] and MS 544 [1] do not include the design of wood dowelled mortise and tenon connections. BS 5268 especially excluded the traditional methods of timber construction which have been employed successfully over a long period of time [7]. Due to the lack of proper guidance and references, current designers may only consider using the steel dowel as the fastener for mortise and tenon joints as outlined in BS 5268 and the American National Design Specification for Wood Construction (NDS) [10] and not wood dowels. As a consequence, joints become very

expensive and preference is given to cheaper dowels with only a small number of bolts. Hence, the investigation on the comparison of performance of wood and steel dowel is required. Kempas species has been selected for this study since it is one of the easily available and common species for structural member. The specific objective of this study is to experimentally obtain the load-carrying capacities of the connections when fastened using wood and steel dowels by loaded in bending. The value of concerns is the proportional limit, 5 % offset diameter, ultimate load capacity and bending moment of the connections. It is also to identify the mode of failure of the dowels and the physical behavior of mortise and tenon failures.

## **Bending Moments of Mortise and Tenon Joints**

Bending moments in mortise and tenon do have some resistance, though it is commonly simplified as pin-jointed connections. The tenon member will rotate around the corner of the tenon shoulder once a bending moment is applied to a single dowel connection. Resistance to bending is provided by the lateral strength and stiffness of the dowel. It is acting at a lever-arm from the effective centre of rotation to the dowel centre line. The effective centre of rotation is at the corner of the tenon shoulder located at B (Figure 1), creating an effectively solid hinge point [11]. Moment rotation at A is the value of force at the load ( $P_1$ ) times the distance of  $d_1$  and equals to force at dowel ( $P_2$ ) times the distance of  $d_2$ .

$$M_A = P_1 \times d_1 = P_2 \times d_2$$

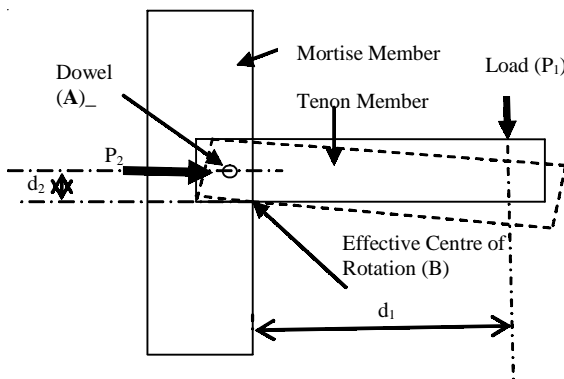

Figure 1: Effective Centre of Rotation at Corner of the Tenon Shoulder

Structural performance of dowels for Malaysian species is hardly found. As for now, only bending and withdrawal strengths of dowels for Malaysian timber species namely Nyatoh (a species of Sapotaceae), Ramin (*Gonystylus* sp.) and Rubberwood (*Hevea brasiliensis*) have been reported by Ahmad *et al.* [12]. Their finding was for mortise and tenon dowelled with two fasteners and meant for furniture uses. In their studies, dowels made from Rubberwood are recommended in terms of application wise.

### **European Yield Model (EYM)**

Design codes require that structures remain elastic under gravity loads. Therefore, it is important to know the yield point, when the plastic deformation begins, and ductility, how much plastic deformation the structure can undergo without significant loss of strength. In timber connections, the yielding of assemblies is the result of a combination of the wood and connector deformations which eventually lead to the failure of the assembly. A series of equations based on the yield theory were developed by Johansen [1949] enabling one to predict the yield mode and resistance of dowel-type connections. Therefore, in analyzing the properties and behavior of mortise and tenon joints when fastened with wood and steel dowel, the ultimate yield models developed by Johansen's [1949] yield theory and expanded upon by Larsen [13] have been applied [6].

EYM describe the mechanism by which the components of a timber connection are deformed beyond the elastic region. The equations based on this theory predict the load-carrying capacity of a single dowel, per shear plane, loaded perpendicular to the axis. It is depending on the material properties of the dowels and on the geometry of the connections as stated in National Design Specification for Wood Construction [1]. The 2001 AFPA requires the calculation of lateral connection design values for all applicable yield modes, the smallest value being the design value corresponding to the predicted yielding mechanism.

### **Experimental**

Six (6) series of tests each were composed from Kempas. These readymade specimens prepared by the local timber manufacturer were kept in controlled conditioned with  $20 \pm 3$  °C and  $65 \pm 2$  % relative humidity.

The tenon was tight in the mortise with less than 2 mm gap between tenon width and mortise length. The actual structural size of column and beam connected with mortise and tenon joint inserted with single dowel were tested and observed. Pre-drilling of the timber elements, in exact size as possible to the dowel diameter was adopted in all specimens. All dowel diameters were cut with  $\pm 1$  mm to 20.6 mm diameter. A gap within 1 mm was allowed within the dowel and the pre-drill hole. Wood dowels were also made of Kempas. Nominal moisture content of the specimens was within 11 % at the time of test. The rate of loading was applied at 7.0 mm/min for all tests for steel dowel and 9.0 mm/min for wood dowel. These constant rates were set to achieve maximum load in not less than 6 minute and not more than 20 minute in accordance to ASTM D 198 [1997]. Limiting rotation was defined by the maximum stroke of the hydraulic jack (250 mm). The peak load at this rotation had been reached once the connection stiffness had stopped increasing.

### **Bending Test Set Up**

The configuration of bending test set up is shown in Figure 2. Five (5) numbers of Linear Voltage Displacement Transducers (LVDT) denoted as 1, 2, 3, 4 and 5 were mounted on the column and beam to measure the respective displacements. Loading was applied in the direction perpendicular to the grain of the beam member, in the axis of the beam, at 1000 mm from the face of column member. Figure 3 shows the actual experimental set up of the bending test.

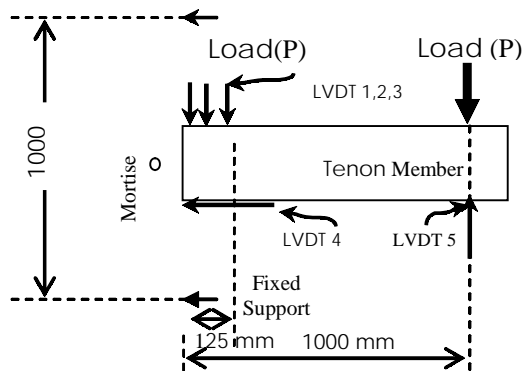

Figure 2: Configuration of Experimental Bending Set-up





Figure 3: Experimental Bending Set-up

### Specimens Geometry Selection

Mortise and tenon were made of two pieces of timber dimensioned as  $200 \times 200 \times 1200$  mm and  $100 \times 150 \times 1000$  mm respectively. A square mortise hole dimensioned with  $41 \times 100 \times 150$  mm was made at each of the column, whilst the tenon is at one end of each beam with  $41 \times 89 \times 150$  mm in dimension. Tenon thickness and distance from the face to the tenon was 41 mm for a 20.6 mm peg (twice the peg diameter). A gap, typically 10-15 mm, was left between the end of the tenon and the mortise base to ensure that as the timber shrinks the tenon does not come to bear on the mortise. The plan view of mortise and tenon configuration is shown in Figure 4.

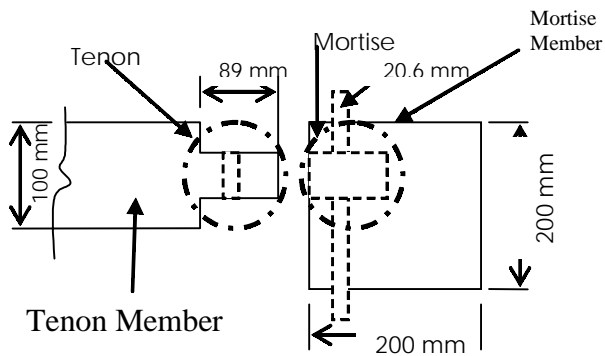

Figure 4: Plan View of Mortise and Tenon Configuration

## Results and Discussions

Typical load-displacement curve measured during testing is shown in Figure 5. Initially, the response is linear elastic, where a linear increase in displacement corresponds to a linear increase in load. Later a non linear load-displacement curve develops due to mortise, tenon, or dowel failure. It was found that the rotational responses are similar to all three tests for each type of dowel and are approximately linear at 4 kN for steel dowel and at around 2.8 kN for wood dowel.

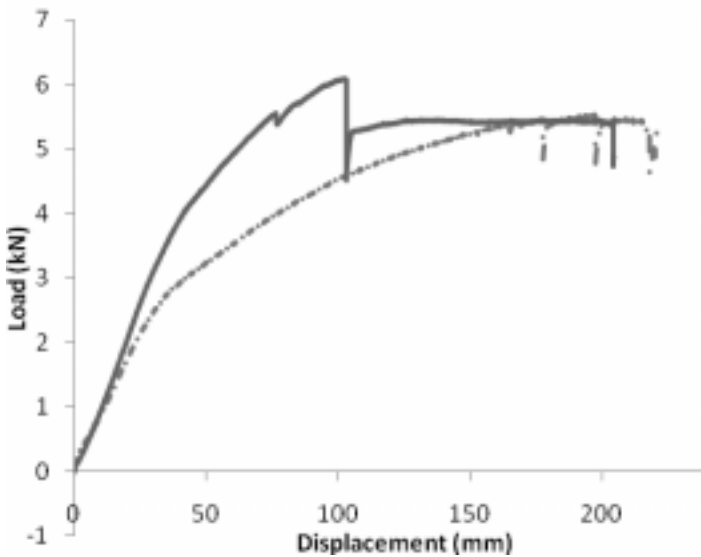

Figure 5: Typical Load versus Displacement Curves

Stiffness of steel dowel keep increasing until it reach maximum load at 6.09 kN, after which rotational stiffness decreases by the sudden drop, followed by smooth plateau associated with tenon end crushing on the mortise. Wood dowel shows lower stiffness with the maximum load of 5.32 kN. Initial linear responses are governed by the rotation of dowel, until the tenon end get in contact with the mortise, which the stiffness for wood dowel increases due to bearing. The rigid steel has pried the tenon hole but the flexibility and densifying of wood dowel allows the bearing to slowly dense and yield.

The bending moment at which the dowel yields can be calculated from the ratio of the dowel to corner of tenon shoulder lever arm and distance from the load point to the centre of rotation. Bending moment at centre of rotation (Table 1) of wood dowel mortise and tenon joint is found approximately 12 % lower than steel connection.

Table 1: Bending Moment at Centre of Rotation

| Type of dowel | Peak Load (kN) | Bending Moment at Centre of Rotation (kNmm) |
|---------------|----------------|---|
| Steel         | 6.09           | 5,481                                       |
| Wood          | 5.32           | 4,788                                       |

Dowel failure occurred as one (or both) dowels sheared, bent, or a combination there of (Figure 6). Wood dowel failure in bending may be described theoretically as a variant of National Design Specification (NDS) for Wood Construction 2005 Edition [10] yield mode  $III_s$  where a single plastic hinge is formed in the wood dowel accompanied by crushing in the mortise. In this case, steel dowel is found to fail in Yield Mode  $I_m$  (Figure 6 and 7 (a)). Wood dowel failed in Yield Mode  $III_s$  as shown in Figure 7 (b). Yield Mode  $I_m$  is when wood crushing in the tenon, a mode that is typical of a stiff dowel. This indicates that mortise and tenon joint with steel dowel performed better than mortise and tenon joint with wood dowel.

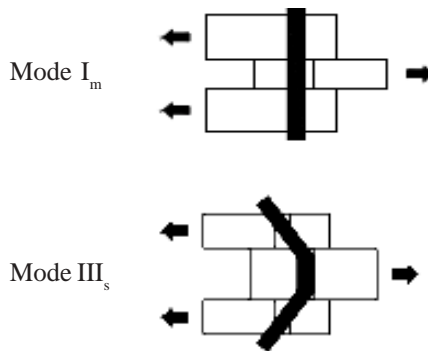
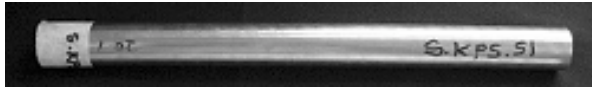

Figure 6: Double Shear Yield Limit Model from National Design Specification for Wood Construction (AFPA) (2005)



(a) Steel dowel



(b) Wood dowel

Figure 7: Form of Dowels after Testing

## Conclusions

Results presented in this paper are the initial findings of an ongoing investigation into the analysis of Kempas connections. It was found that maximum bending load capacity of mortise and tenon when fastened with steel dowel and wood dowel is in average of 6.09 kN and 5.32 kN respectively. Bending moment of mortise and tenon connection when fastened with steel dowel is found approximately 12 % higher than when fastened with wood dowel. Yield Mode of steel dowel is in Mode  $I_m$  that is wood crushing in the main member shows that steel dowel stiffness is greater than wood strength. Yield Mode of wood dowel is in Mode  $III_s$  that is the dowel yield in bending at one plastic hinge point per shear plane and associated wood crushing.

## Acknowledgement

The authors would like to thank the Ministry of Science, Technology and Environment, Malaysia for funding the project through FRGS, UiTM.

## References

- [1] Malaysian Timber Standard, MS544: Part 5. 2001. *Code of practice for structural use of timber. Part 5 – Timber joints*. Department of Standard Malaysia (SIRIM).

- [2] Brungraber, R. 1985. *Traditional timber joinery: A modern approach*. PhD Thesis, University of Stanford.
- [3] Erikson, R. G. 2003. *Behaviour of traditional timber frame structures subjected to lateral loading*. PhD Thesis, University of Wyoming.
- [4] Bulleit, W. M., Sandberg, L. B., Drewek, M. W. and O'Bryant, T. L. 1999. Behaviour and modeling of wood-pegged timber frames. ASCE, *Journal of Structural Engineering*, vol. 125, no. 1, January, pp. 3-9.
- [5] Sandberg, L. B., Bulleit, W. M. and Reid, E. H. 2000. Strength and stiffness of Oak pegs in traditional timber-frame joints. ASCE, *Journal of Structural Engineering*, 2000. vol. 126, no. 6, June, pp. 21620.
- [6] Miller, J. F. 2004. *Capacity of pegged mortise and tenon joinery*. Master Science Thesis, University of Wyoming.
- [7] Shanks, J. D. and Walker, P. 2005b. Experimental performance of mortise and tenon connections in green Oak. *The Structural Engineer*, pp. 40-45.
- [8] Walker, C. R., Fonseca, F. S., Judd, J. P. and Thorley, P. R. 2008. Tensile capacity of timber-frame mortise and tenon connections. *10<sup>th</sup> World Conference on Timber Engineering (WCTE)*, Miyazaki, Japan.
- [9] British Standard Institution, BS 5268. 2002. *Structural use of timber – Part 2*. British Standard Institutes.
- [10] American Forest and Paper Association (AF&PA). 2005. *National design specification (NDS) for wood construction*. 2005 Edition, AF&PA American Wood Council, Washington, D.C., pp. 174.
- [11] Shanks, J. D. 2005a. *Developing rational design guidelines for traditional joints in Oak frame construction*. Unpublished Phd. Thesis, University of Bath, United Kingdom.

- [12] Ahmad, S., Haji Amin, A., Ali, R. and Md Tahir, H. 1992. Withdrawal and bending strengths of dowels from three Malaysian timbers. *Journal of Tropical Forest Science* 6(1): 74-80. pp. 74-80.
- [13] Larsen, H. J. and Thelanderson, S. 2003. *Timber Engineering*. Wiley, pp. 316-322.