

HEAT AND HELIUM PRODUCTION DURING EXOTHERMIC REACTIONS BETWEEN GASES THROUGH PALLADIUM GEOMETRICAL ELEMENTS LOADED WITH HYDROGEN

GIUSEPPE AGELAO and MARIA CARMELA ROMANO
*Dipartimento di Ingegneria Nucleare, Università di Palermo
Viale delle Scienze, 90128 Palermo, Italy*

FRANCESCO ITALIANO* *Istituto di Geochimica dei Fluidi—CNR
via Ugo La Malfa 153, 90146 Palermo, Italy*

Received February 16, 1998

Accepted for Publication January 12, 2000

In this research, the effect of the shape of hydrogen-loaded palladium elements on exothermic reactions between gases is shown. It was found that an element with parts of its surface next to each other spontaneously triggers reactions, whereas an element whose surfaces are not next to each other needs outside triggering. The heat developed makes the temperature of the elements rise even by a few hundredths of a degree centigrade.

Through photographic techniques, it was shown that the elements, when releasing heat, emit radiation connected to nuclear fusion reactions. These reactions, confirmed also by the analysis of the used hydrogen, showed helium formation. All these tests have confirmed the reproducibility of the phenomenon.

I. INTRODUCTION

In 1989, the electrochemistry experiments conducted by M. Fleischmann and S. Pons¹ indicated that nuclear fusion reactions may occur in solids at ambient temperature. This kind of fusion was described as "cold fusion." It is related with the crystalline structure of the solid, whose atoms vibrate incessantly around their re-

ticular positions. In fact, the lattice's vibrational energy, which is quantized in elastic waves called phonons, propagates inside the solids at the speed of sound, and it is capable of moving the collided atoms. A collided atom may move and, during its path, may collide again with another atom with an energy so high as to be able to overcome the repulsive Coulomb barrier of the atomic nuclei and to fuse them. This kind of nuclear fusion has a low probability at temperatures for which the physical state is solid. However, the fusion reaction is more frequent with light particles (i.e., hydrogen and deuterium atoms), which possess high mobility in the lattice. Therefore, the solids that absorb the largest number of light atoms, like Pd, Ti, etc., are those most suitable for nuclear fusion reactions. The experimental approach that has been followed most frequently is that employing these solids, with a more or a less modified structure, immersed in electrolytes under the action of electric fields.

A different research path, which was adopted in the present work, is that based on solids immersed in gases. It focuses attention on the solid's surface, regarded as a frontier for the exchange of matter between the inside and the outside of the solid. The geometrical shape of the latter is of fundamental importance in the induction of exothermic reactions, either chemical or nuclear in nature, which seem to occur preferentially in a thin surface layer.

The solid employed was Pd, charged either with H₂ or with D₂. According to the shape of the Pd sample, heat production by exothermic reactions occurred spontaneously or had to be triggered by an external thermal solicitation.

*E-mail: italiano@igf.pa.cnr.it

During the same experiments, helium was also produced, and it was detected by mass spectrometry in concentration up to 217 ppm v, well above the initial helium concentration in the adopted hydrogen (38.2 ppm v).

II. GENERAL ASPECTS

In this research, gas absorption into solids is examined in relation to heat production by **exothermic** reactions. The aforementioned absorption into a solid can happen only through the separating surface between the solid matter and the surrounding gas. The atoms or molecules of the absorbed gas place themselves in the solid interstices and, solicited by thermic excitation, continuously migrate through it, interacting among themselves and with the atoms of the host matter. Because of nuclear fusion reactions, some of these interactions generate new atoms whose production is **quantitatively insignificant**.

An important aspect of the phenomena concerning the surface of solids in relation to their **shape**^{2,3} was **examined**. Assuming a homogeneous spatial distribution of matter, the ratio between the surface area that delimits a solid body and its volume (**S/V**) plays a fundamental role. **Furthermore**, if interactions between surface portions of a solid body also come into play in a phenomenon, its shape takes on a remarkable importance.

Interactions among different portions of the surfaces can occur in many configurations: in the roll (Fig. 1), that is, a foil in the shape of a strip wound in a spiral, each portion of the front face looks at a portion of the back face of the same foil. In the bellows (Fig. 1), that is, a foil folded within the boundaries of a parallelepiped; the portions of the same surface look at each other. Generally, patterns of different shapes suitably folded and porous bodies present mutually facing surfaces?

Phenomena correlated to shape also concern a body divided into more parts, even reduced to dust. In this case,

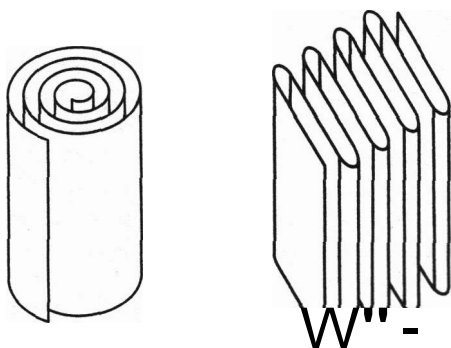

Fig. 1. I category palladium elements: left, the roll; right, the bellows.

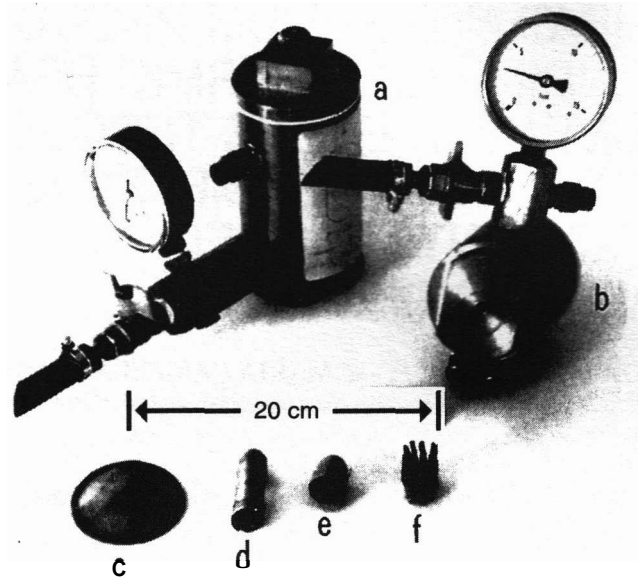

Fig. 2. (a) 320-cm³ yellow-brass container; (b) 187-cm³ yellow-brass container; Pd samples: (c) disk; (d and e) rolls; and (f) bellows.

the surface ratio of all the dust grains with respect to the volume is **remarkable**.^a In fact, each granule looks at the surrounding ones whose number depends on their instantaneous spatial distribution.

Palladium was chosen as the solid because of its remarkable features in absorbing gas; hydrogen was chosen because of its high permeability into solids.⁵ At room temperature, hydrogen, pressurized between 8 and 14 bars, is easily absorbed by palladium in great quantity. At saturation, 1 cm³ of palladium absorbs about 1 g of hydrogen, that is **H/Pd = 0.79**.

The speed of hydrogen absorption mainly increases with the extension of the sample surface in relation to its volume; that is, it increases with the **S/V** ratio. For high ratios, as in the samples having a roll or bellows shape, saturation is reached in **—20 min** or less. Hydrogen in a palladium sample remains in dynamic equilibrium if sealed in a constant temperature container, filled with pressurized hydrogen (Fig. 2). Tests have shown that after many months, no pressure variations are observed;

^aThe surface increment in a body subdivided in equal parts can be easily calculated. In fact a cube divided into 8ⁿ equal smaller cubes (with **n = 1,2,3,...**) presents a **total** surface of a value **S_n = 2ⁿ · S**, where **S** is the surface of the starting cube. The same result is valid for a sphere of a volume equal to 8ⁿ equal smaller spheres; in general, this rule holds for the regular polyhedra and, with a good approximation, for any other form if **n** is large enough. Therefore, the shape ratio for dust, with good approximation, is the following: **S_n/V = 2ⁿ · S/V**.

TABLE I
 Mass Spectrometric Helium Analyses*

Model ^a	Weight (g)	Total Surface (cm ²)	Reactive Surface (cm ²)	Time (10 ⁵ s)	⁴ He (ppm v)	A ⁴ He (ppm v)	Production Rate (⁴ He atoms·cm ⁻² ·s ⁻¹)
Roll 1	40.6	327.32	151.1	6.843	112.7 ± 14.4	74.6 ± 16.0	1.83 × 10 ¹⁰
Roll2	93.7	587.46	270	8.457	217.4 ± 2.7	179.2 ± 4.3	1.87 × 10 ¹⁰
Disk	35.0	16.30	0	6.843	48.7 ± 2.4	14.5 ± 3.5	—

*Models, characteristics, and results of palladium samples adopted during nuclear fusion tests. The ⁴He is the total helium concentration measured in the sampled gas, while A ⁴He represents the concentration of helium excess in respect to the adopted hydrogen. The production rate = ⁴He production for unity of time and reactive surface.

^aGeometrical characteristics of the adopted samples:

1. **model roll 1**: from Pd strip (37 × 4.4 × 0.0208 cm) wound in a cylindrical shape of 9 spirals. Dimensions: radius 0.9 cm; height 4.4 cm
2. **model roll 2**: from Pd strip (43 × 6.8 × 0.0267 cm) wound in a cylindrical shape of 10 spirals. Dimensions: radius 1.06 cm; height 10 cm
3. **model disk**: Pd cylinder. Dimensions: radius 1.63 cm; height 0.35 cm.

however, at a microscopic level, variations, shown by gas analysis, have occurred.

Spectrometric analyses detected helium formation clearly due to nuclear fusion reactions started from hydrogen. Since helium production was much higher for geometric models (i.e., rolls) having mutually facing surfaces, it can, therefore, essentially be said that helium is generated through the reciprocal bombardment between those surfaces, called reactive surfaces."

A small part of helium is produced by interactions taking place inside the palladium mass, but most of it is produced by interactions due to hydrogen bombardment, which, going out from a portion of a surface, affects another portion and vice versa. The newly formed helium seems to be deposited in a superficial thin layer of the sample, thus obstructing, as it develops, the interactions between the reactive surfaces, as has been shown by experimental tests with a coil-shaped palladium element.

III. NUCLEAR FUSION REACTIONS

Some tests were carried out with the aim of determining possible helium production due to fusion reactions triggered by palladium.^{6,7} For performing a test, a palladium sample was placed inside a brass container (Fig. 2) under 11 bars of hydrogen pressure for measured time intervals (Table I). Among the possible palladium models, tests were performed using two rolls of different size and a disk (Table I).

Before the tests progressed, gas samples of hydrogen adopted for tests were taken straight from the bottle (10 ℓ, 200 bars) and analyzed to evaluate helium contamination, which was found to be 38.2 ± 1.6 ppm v.

The gas sample was admitted to a static vacuum noble gas purification line, and helium concentration was measured by a computer-controlled quadrupole mass spectrometer^b equipped with two detectors, a faraday cup, and a multiplier, with sensitivities respectively of 1.9 × 10⁻⁴ A·mbar⁻¹ and >75 A·mbar⁻¹. Minimum detectable partial pressure is 5 × 10⁻¹⁴ mbar on the multiplier, which allows detection limits for helium of 10⁻¹² mbar.

Since quadrupole mass spectrometers give analytical results as partial pressure values, helium concentration was calculated against a gas standard containing a known amount of helium. Atmospheric air was used as a running standard considering its homogeneous helium concentration (5.24 ppm v) on a global scale. Other standard gas mixings were adopted to verify the linear response of the quadrupole mass spectrometer in the concentration range 1 to 1000 ppm v.

Every sample was analyzed following a rigorous procedure that consists of alternatively running a standard and a sample. Gases to be analyzed were admitted through a special vacuum valve of known volume (0.3056 ml), where a pressure gauge was fitted. In this way, the analytical result (partial pressure in millibars) was referred to a sample having known volume and pressure. This allowed the calculation of helium concentration as follows:

$$[\text{He}]_s = [P_s / (P_g \times [\text{He}]_g)] \times IP_g / IP_s ,$$

where

[He] = helium concentration

P_s = measured helium partial pressure of the sample

^bModel VG Quartz 100 from VG Instruments.

P_g = measured partial pressure of the gas standard

IP = inlet pressure

g and s subscripts = gas standard and sample, respectively.

Measuring errors have been calculated following the minimum squared errors method on at least five measurements performed on both air standard and gas sample. Typical helium blank values were 10^{-10} mbars. Possible contribution on mass 4 by cracking of higher masses (i.e., ⁴⁰Ar, ¹²C, etc.) was also found to be negligible (10^{-11} mbars).

Results showed that helium was produced inside the brass container, increasing the original helium concentration of the adopted hydrogen to the values listed in Table I. Since helium was mainly produced during experiments involving rolls, the presence of reactive surfaces seems to be of basic importance for fusion reactions. Calculations were performed in order to quantify the helium production. Taking into account the free volume of the container (≈80 ml) and the total pressure (11 bars), a total amount of helium produced by fusion processes can be calculated as follows:

$$He_{atoms} = Q\Delta He V_m^{-1} N_A,$$

where

Q = amount of gas contained inside the container (standard temperature and pressure conditions)

ΔHe = concentration of helium produced by fusion reactions

V_m = molar volume (22414 ml)

N_A = Avogadro number (6.022 × 10²³).

Considering the extension of the reactive surfaces and the test duration, a very similar production rate was calculated for both rolls (Table I).

The obtained results are reminiscent of the well-known theoretical reactions proposed in 1938 by Bethe and Weizsacker to interpret the energy production by nuclear fusion occurring in stars. Starting from hydrogen, through reactions known as a "hydrogen-hydrogen cycle" or a "proton-proton chain," it is possible to form ⁴He and to generate energy as in the following schematic reaction:

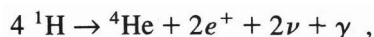

with the production of -27 MeV of total energy.

It is worth noticing that during test development, the temperature of the brass container (weight 8.2 kg, Fig. 2a) measured on the outside surface was always 0.1 to 0.2°C above room temperature.

IV. TEMPORARY HEAT PRODUCTION AND ELEMENT SHAPE

As already mentioned, a palladium sample, kept inside a container with pressurized hydrogen (8 + 14 bars), absorbs a great quantity of gas, so a dynamic equilibrium of an undetermined time duration is developed.

If more hydrogen is added, only the pressure in the container increases proportionally. On the contrary, if hydrogen is taken out, new equilibrium conditions are established; at first the pressure drops, and then it slowly starts to grow again up to a new equilibrium value because a part of the absorbed hydrogen comes out of the sample. An experimental test trial was carried out on a container of a small volume in such a way that modest variations of hydrogen quantities could correspond to easily measurable pressure variations.

When the sample is removed from its container and is placed in the open environment, the equilibrium conditions no longer exist; the new gas (air)⁸ is at a lower pressure (atmosphere). The absorbed hydrogen starts to go out from the palladium and interacts with the new gas, which tends to go into the palladium. Therefore, heat production from the exothermic reaction makes the palladium temperature⁵⁻⁷ rise up to a maximum, after which it decreases and tends toward room temperature since the absorbed hydrogen is released from the metal (Fig. 3).

Heat production from hydrogen burning in the atmosphere is a well-known chemical reaction that probably occurred even during our experiments. Hydrogen burning in the atmosphere, however, needs the addition of an external energy source to start. It is worth noticing that in our case no energy source was added but the energy produced inside the palladium samples by fusion nuclear reactions.

The main palladium elements used in this research are divided into two types according to the value of the shape ratio S/V and the reactive surface extension.

IV.A. First Category

These elements have a large shape ratio and very large reactive surfaces. They spontaneously generate heat (Figs. 3a, 3b, and 3d), presumably due to the reciprocal bombardment, mainly of protons (Figs. 4b and 4d; Figs. 5b, 5d, and 5f) between the reactive surfaces.

The simplest shapes are the roll and the bellows shown in Fig. 1. To prepare the aforementioned elements, the palladium is treated according to the following procedures:

1. Rolling.

2. Annealing for 24 h or more at a temperature between 400 and 800°C for a structural settling of the metal crystal grains and gas⁸ elimination. The sample becomes soft and easily shaped.

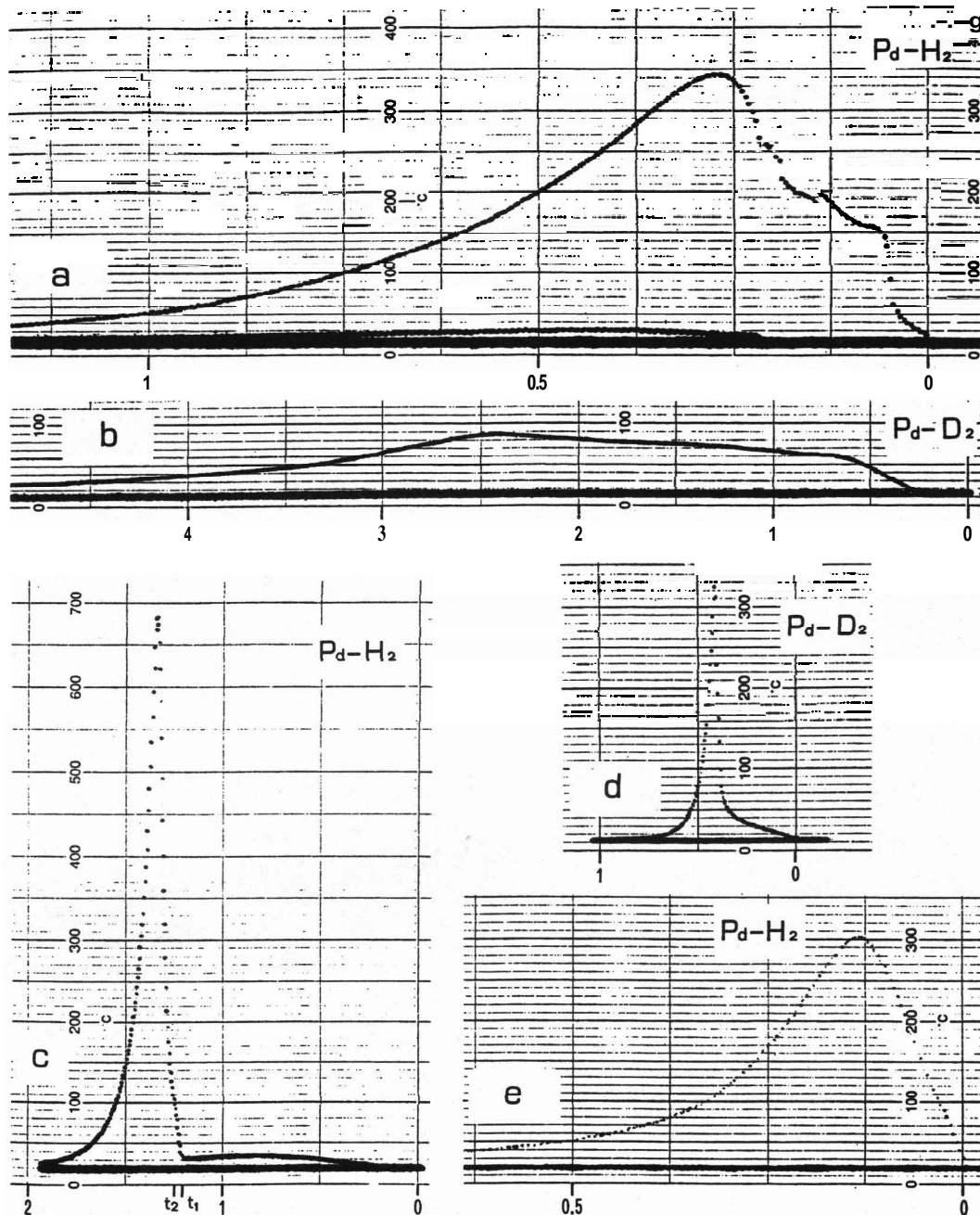

Fig. 3. Temperature increase in the palladium samples. Abscissa: time in hours. Ordinate: temperature in degrees Celsius. Straight line below: room temperature. In 3a, the intermediate curve refers to the bottle temperature. The other data are in Table II.

3. Cleaning the surface with thin-grain-size abrasive paper (or cloth). In this way, the oxides formed during the open-air annealing are removed, and the surface increases slightly due to the tracks left by abrasion.^{2,12,13}

4. Cleaning with water and detergent. Drying with paper followed by heating at a temperature between 50 and 80°C for several minutes.

5. Sample shaping.

IV.B. Second Category

These are elements with a small shape ratio and without reactive surfaces, which generate heat only if stimulated. Among them, there are the sphere and all solids having convex surfaces. At equal volume, the sphere is, among these, the shape with the smallest shape ratio: $S/V = 3/r$, where r is the radius. They release heat only if any one of their parts is heated up to $70 \div 80^\circ\text{C}$

TABLE II
Data Related to Tests*

Figure 3 ^{a,b}	Category	Model	Weight (g)	Volume (cm ³)	Gas
a	I	Roll	38.25	$42.4 \times 4.41 \times 0.017 = 3.18$	H ₂
b	I	Roll	35.18	$34.5 \times 3.45 \times 0.0246 = 2.93$	D ₂
c	II	Disk	61.48	$\pi \times 1.652 \times 0.598 = 5.11$	H ₂
d	I	Roll	35.18	$34.5 \times 3.45 \times 0.0246 = 2.93$	D ₂
e	I; II	Filing	8	0.66	H ₂

*In the samples consisting of a single body (roll, bellows, and disk), the thermocouple was placed near the geometrical center of the element.

^aFigure 3, (a) and (b): tests in a closed bottle with air at room pressure. The sample saturated with gas was placed in its center. Some water condensed on the inside wall. In (c), in the time gap t_2 to t_1 the sample was heated up.

^bFigure 3, (c), (d), and (e): open-air test. The gas-saturated sample was placed in an open-air environment. In (e), the recorded temperature is referred to that in the center of the crucible (66 g), where the filing, dropped from the height of 12 cm, collected.

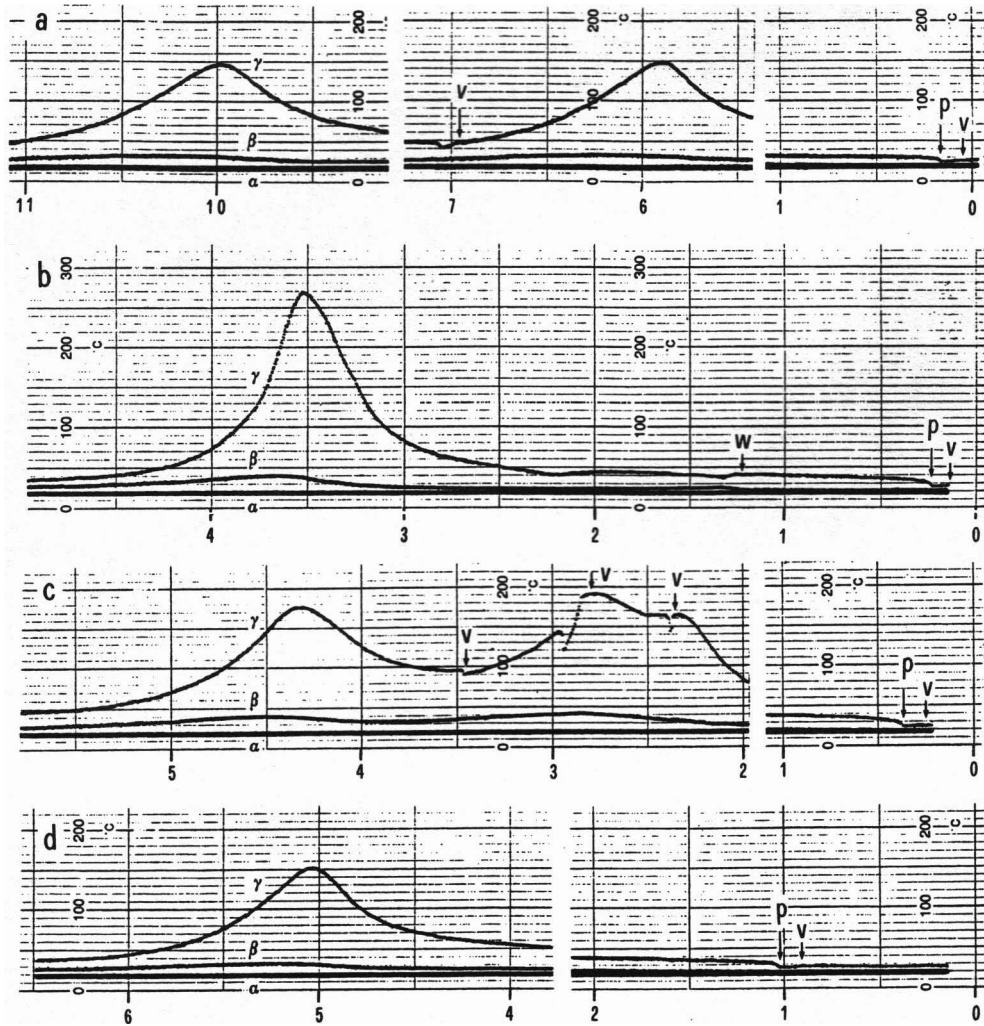

Fig. 6. Palladium coil. Temperature behavior. Abscissa: time in hours. Ordinate: temperature in degrees Celsius. **Curve a:** room temperature. **Curve beta:** barycenter of the brass disk (2.6 kg). **Curve gamma:** intermediate turn of the coil (0.203 kg). Symbols: p: pressure; v: vacuum; w: heating. Other data in Table III.

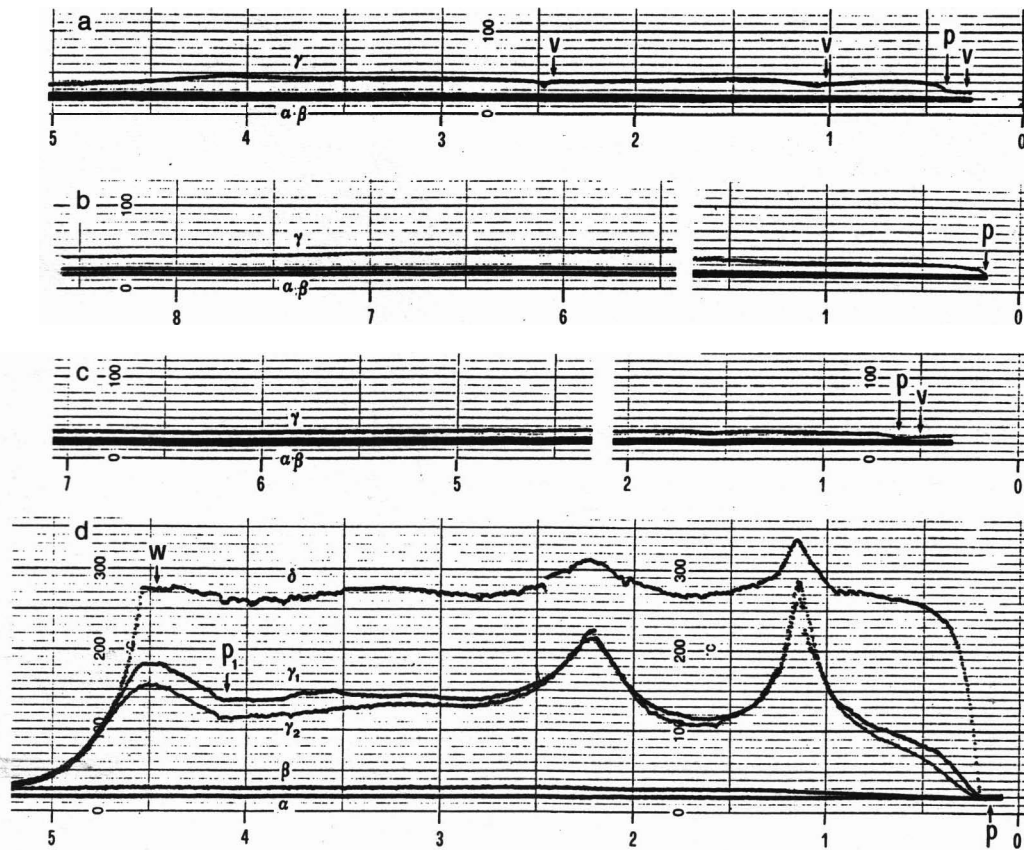

Fig. 7. Palladium coil. Temperature behavior. Abscissa: time in hours. Ordinate: temperature in degree Celsius. Curve α : m temperature. Curve β : barycenter of the brass disk (2.6 kg). Curve γ : intermediate turn of the coil (0.203 kg). In (d), p_1 indicates the increase imposed on the hydrogen pressure inside the coil, from 10.4 to 12.5 bars. Curve δ : electric heater at 1 cm from contact with the coil. Curve γ_1 : point of the coil at 1 cm from contact. Curve γ_2 : point of the coil diametrically opposite to the former contact point. In w, the electric heater has been switched off. Symbols: p: pressure; v: vacuum; w: heating. Other data in Table III.

recorder with six thermocouples was connected to a digital reader accurate to one-tenth of a degree. Figure 3 shows some of the results from some tests, and the relative data are reported in Table II. It can be noted that after reaching its peak, the temperature goes back to that of the surroundings.

V. CONTINUOUS HEAT PRODUCTION ELEMENT

A continuous heat production element must be constantly fed with hydrogen. This can be easily obtained with the second category of elements, by obtaining inside them a cavity communicating with a hydrogen bottle. Good elements are tubular wireworks conveniently folded in such a way that reactive surfaces are facing each other.

One of these simulations consisted of heating up a random point of the coil (see point W on Figs. 6b and 7d). Another one consisted of keeping the inside of the

palladium tube in a vacuum for some minutes, to "free" the superficial layer clogged by gases heavier than hydrogen, which kept on depositing (see point v on Figs. 6b, 6c, 6d, 7a, and 7c).

In this work, a system was used essentially consisting of a palladium tube with a circular section^c bent into a coil shape with loops next to each other and connected to a hydrogen container under pressure (8 ÷ 14 bars) (see Fig. 8).

Hydrogen permeates the wall of the palladium tube by moving from the inside surface to the outside surface, where most of the exothermic reactions take place with the gases in the air, which tend to penetrate into it. A remarkable contribution comes from the hydrogen atom ions that emerge from the outside surface of one loop of the coil and that affect the other loops. This is the

^c An elliptical or rectangular section increases the area of the reactive surfaces. Compatibly with the diameter size, the tube internal surface is also a reactive surface.

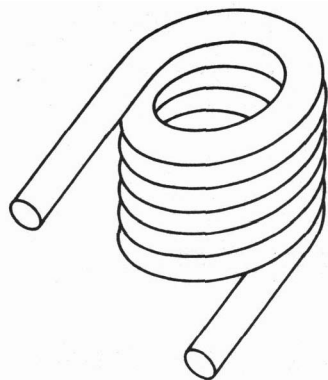

Fig. 8. Palladium element obtained with a tube shaped in a coil pattern with the turns next to each other (tube length 102.5 cm, inside diameter 4 mm, outside diameter 6 mm, weight 184.25 g). Inside it contains 18.13 g of filing sealed by two palladium-shaving corks (0.57 g).

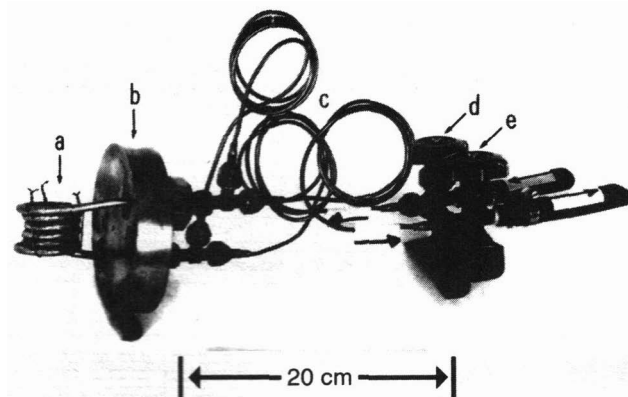

Fig. 9. Main part of the heat production system: (a) palladium tube coil, 102.5 cm, 203 g; (b) brass disk, 2.6 kg; (c) copper capillary tube circuit; (d) hydrogen input valve; and (e) hydrogen output valve.

contribution from the reciprocal proton bombardment between reactive surfaces (Figs. 4b, 4d; 5b, 5d, and 5f).

Some test results, reported in Figs. 6 and 7, show the temperature progression of the coil. As can be seen, the goal of heat production has been reached, but the goal of power regulation has not been fully attained. In fact, power drops as the hydrogen pressure inside the coil decreases. The power increment, instead, seems to be always casual, in any type of working condition.

Therefore, at the moment, it is not possible to stabilize the power on preestablished values, although, after each test, it tends to a constant low value. At the present value, the coil stays at 3°C above room temperature with a small hydrogen consumption ($-100 \text{ cm}^3/\text{h}$).

V.A. Procedure and Results

The palladium coil, fixed on a brass plate^d (diameter 11.9 cm, thickness 2.51 cm, weight 2.6 kg), was connected to a copper capillary tube with two valves (Fig. 9), which allowed it to be connected either to a pressurized 10-ℓ hydrogen bottle ($8 \div 14$ bars) or to another high vacuum 7-ℓ bottle. Before being assembled, the palladium tube went through treatments 2, 3, 4, and 5 already described in Sec. IV.A for the elements of the first category.

The coil was kept in a vacuum for ~ 10 min. Then, it was connected to a pressurized hydrogen bottle, and after a delay of a few minutes, exothermic reactions occurred between the hydrogen that had permeated through

^dThe plate, besides functioning as a bearing structure for the circuit, helps to remove the air from the extremities of the palladium tube which, held tightly by conical joints, crosses it.

the thickness of the palladium tube and the air gases that pressed on the outside coil surface. Figures 6 and 7 show the temperature evolution, which happens either spontaneously or following external stimulation. In any case, in these kinds of experiments, the temperature always remains higher than the surroundings.

One of these stimulations consisted of heating up a random point of the coil. Another one consisted of keeping the inside of the palladium tube in a vacuum for some minutes, to "free" the superficial layer clogged by gases heavier than hydrogen, which kept on depositing. Such gases are impurities from the hydrogen bottle, and some products from nuclear fusion reactions occurred inside the tube. Some trials were run by covering the coil with aluminum or Plexiglas covers that were either airtight or not airtight. Figures 6 and 7 show the results from some tests, and Table III reports the relative data.

VI. RADIATION FROM THE PALLADIUM COIL

During the low-power operation, with a temperature rise of 15°C decreasing slowly to 3°C with respect to the room temperature, it was possible to make long-range observations aimed, above all, to a first evaluation of the radiation that emanated from the nuclear fusion reactions, currently still unknown. At this temperature, it was possible to run tests in a dark room with bare photographic films touching the coil. Radiographic films with a photographic emulsion of 10 μm on each side of the 175-μm-thick support, were used as detectors. Under microscopic examination, the films exposed to the radiation generated in the coil reveal some tracks¹⁴⁻¹⁶ along

TABLE III
Data Relative to Tests with Palladium Coil

Figs. 6; 7	Outside Gas	Coil				Average H ₂ Consumption		Initial H ₂ Pressure (bars)	
		Outside Cover (0.8 ℓ)		Gas Exchange in the Cover	Stimulation~~		(cm ³ /h) ^b		(h)
		Material	Airtight		Heat (w min)	Vacuum (v min)			
6a	Air	---	---	---	---	5; 5	1620	12	12
6b	Air	Aluminum	No	Through holes	5 ^c	5	1320	6.25	12.4
6c	Air	Aluminum	No	Through holes	---	5; 1 5;1/6	2420	6.5	10.9
6d	Air	Plexiglas	No	Through 4-cm ² hole	---	5	1380	5.38	13
7a	Air	Plexiglas	Yes	Suction pump 10 cm ³ /min	---	5; 1; 5	1150	7.5	13
7b	Air	Plexiglas	No	Through 4-cm ² hole	---	---	900	8	12.9
7c	Nitrogen	Plexiglas	Yes	Less than 3 cm ³ /min ^d	---	5	450	24	13
7d	Air	Air	---	---	^e	---	5930	4.33	13

^aShown are the time intervals (in minutes) adopted during the heating of the sample (w min) and during the evacuation of the system (v min). The vacuum v was made in the circuit's section (Fig. 9) that went from the (closed) valve d to the (open) valve e, which included the coil and the copper capillary tube (14 cm³). This section was connected to the high-vacuum 7-ℓ bottle. The heating system was made up of an electric resistance set at one end of a copper rod (10 x 1 x 0.5 cm); the other end was fixed on a middle loop of the palladium coil with a <10-mm² contact between the two metals. In some trials, hot air (-150°C) was blown through a copper tube (of 5-mm diameter) on the palladium coil. In every trial where the coil had an outside cover, some water was formed.

^bIncluded hydrogen dispersing in air without interacting.

^cHot-air heating (150°C).

^dExchange through continuous nitrogen flow (from bottle) in the coil outside cover.

^eContinuous electric heating at constant power.

the path of the charged particles** in the photographic emulsion. These are dotted lines formed by clusters of silver atoms whose size and position mostly depend upon the mass, the energy, and the electric charge of the particle.

Bare films were exposed by putting them directly in contact with the coil, and films covered with black cardboard (0.27 mm thick) were exposed at different distances, always in a dark room. A bare film was rolled up and placed inside the coil. As can be noted (Figs. 4 and 5), the density of the tracks is high in portions of film near the coil. On them, the particles have left longer or shorter tracks according to the angle of incidence. The particles are monatomic hydrogen ions, ions from other elements, and nuclear fusion products, among which there are fast neutrons (Fig. 10c). Every exposed film also reveals tracks of recoil ions formed through the collision of particles with the film atoms (mostly hydrogen atoms and other atoms as carbon, silver, bromine, etc.). There are also star^{14,15} branches generated through the fission of the film's atoms. Figures 4, 5, and 10 show a few of the very many events present in the films exposed to the radiation that emanated from the coil. The little white rings are microbubbles caught in Canada balsam used during microscopic photography.

Figure 11 shows the configuration of an unexposed film, Fig. 11 b that of a bare film exposed in a dark room for 142.5 h; the thin tracks are a characteristic of the film. In Fig. 12, two tracks of alpha particles from natural thorium are shown.

Figures 4, 5, 10, and 12 show, on the left, films with tracks of charged particles and, on the right, regions of the same films enlarged ten times. The photographic emulsion layer closer to the coil is marked with I, the other with II, and for an overexposed film, with III and IV.

VII. CONCLUDING REMARKS

This research work highlighted two basic aspects concerning exothermic reactions induced by hydrogen-loaded palladium samples whenever they are exposed to the same or a different gas.

The former aspect takes into account fusion reactions of hydrogen atoms that produce helium during their stay inside the palladium sample. It has been found that the amount of helium produced is related to the sample shape and to the presence of reactive surfaces. Experimental data have shown that samples having reactive surfaces produce helium at a rate of 18 billion atoms-s⁻¹ · cm⁻².

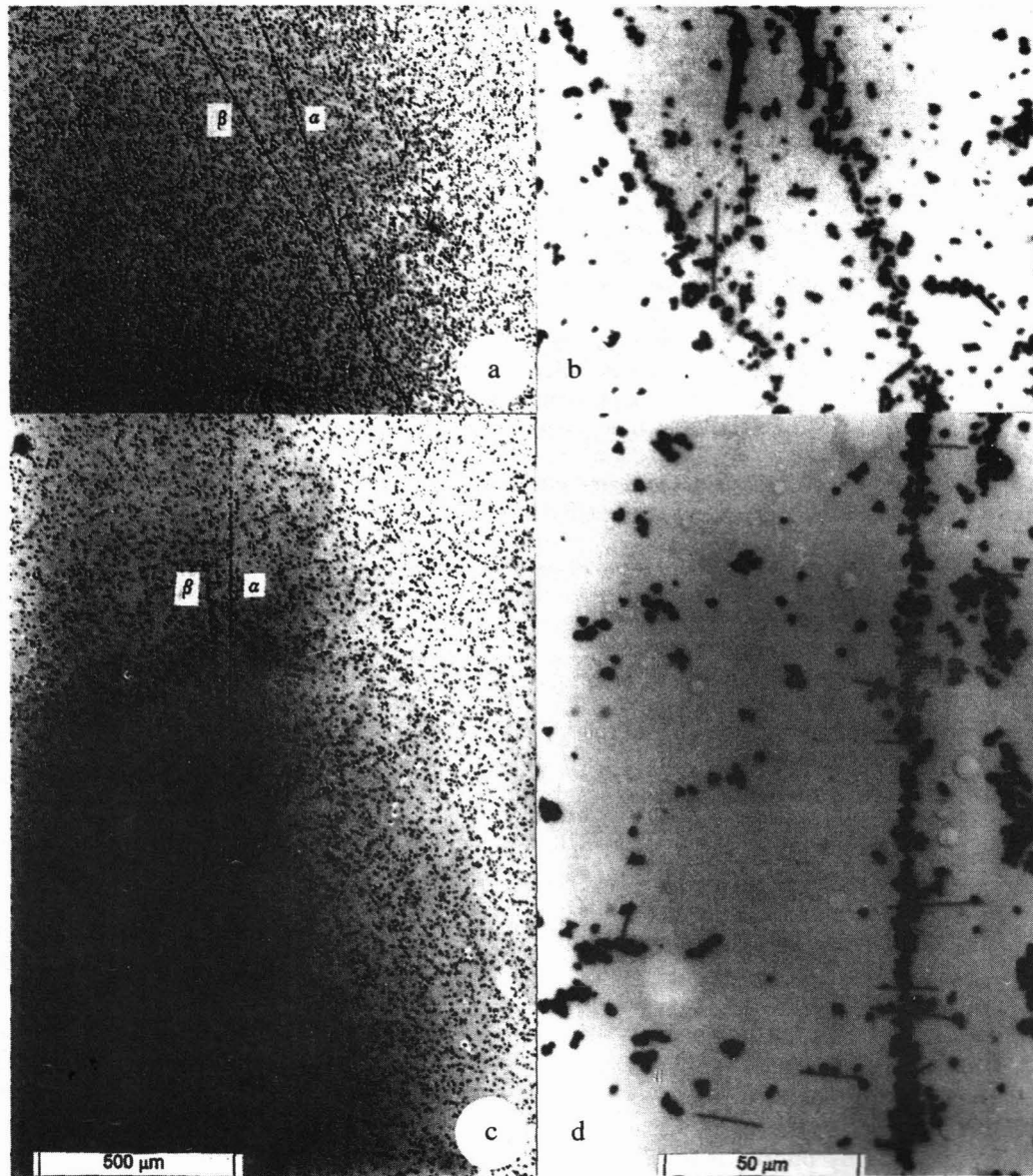

Fig. 10. (a) and (b) Bare film in contact with the outside of the coil, exposure time 20.75 h. Tracks in the IV layer, length: $\alpha = 1.5$ mm; $\beta = 9.21$ mm. (c) and (d) Film wrapped in black cardboard (0.27 mm), exposure time 96.38 h at 65 cm from the coil. A shield made with 2 bricks (2.04 g/cm^3) with a total thickness of 11 cm was placed between coil and film at 20 cm from the coil. Tracks in the I layer, length: $\alpha = 3.22$ mm; $\beta = 1.63$ mm.

The latter aspect concerns other nuclear fusion reactions (tracks in photographic emulsion) and chemical reactions (water formation) that happen together with the aforementioned ones, when palladium samples are taken out of the container, under hydrogen pressure, and exposed to the atmospheric air. The reactive surfaces play a basic role even in this case, since they allow the spontaneous initiation of exothermic reactions that increase the temperature of the model up to hundreds of degrees.

Measurements carried on over long time intervals, 30 cm far from the palladium samples (both inside and

outside the brass container), proved that the increase of radiation to the background (gamma rays, fast neutrons) is negligible.

Nevertheless, the proposed results concern samples made of palladium; we consider it possible that other metals and alloys may have the same behavior. In our opinion, in the light of the results obtained during this research work, the exploitation of a continuous and clean heat source from an exothermic reaction (both nuclear and chemical) induced by the Pd-H₂-air system may be considered possible.

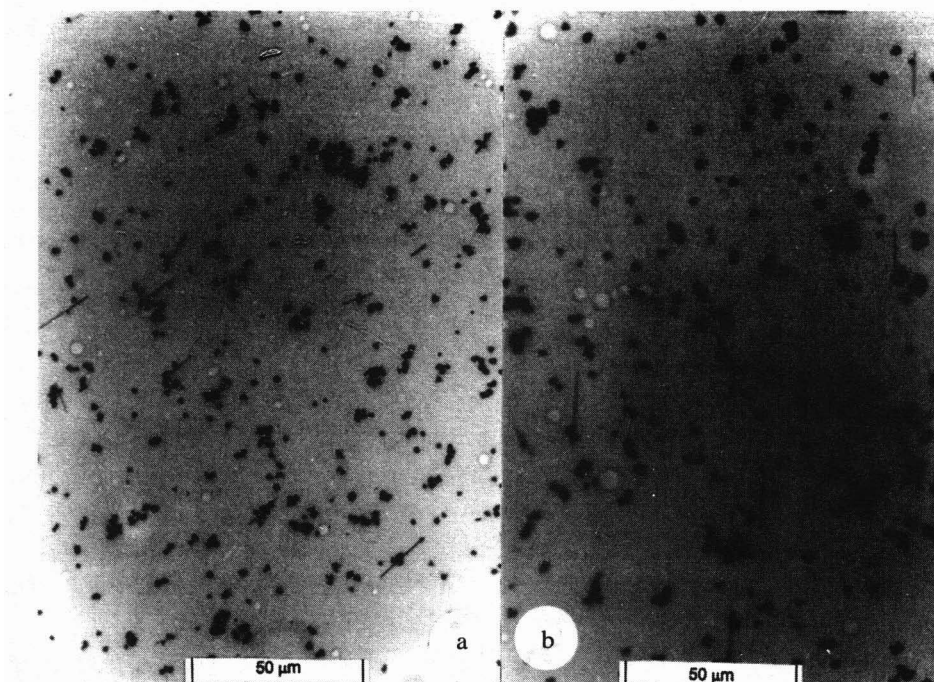

Fig. 11. (a) Unexposed film; beside the Ag atom clusters, there are thin tracks, which are a characteristic of this type of film, (b) bare film exposed for 142.5 h in a dark room.

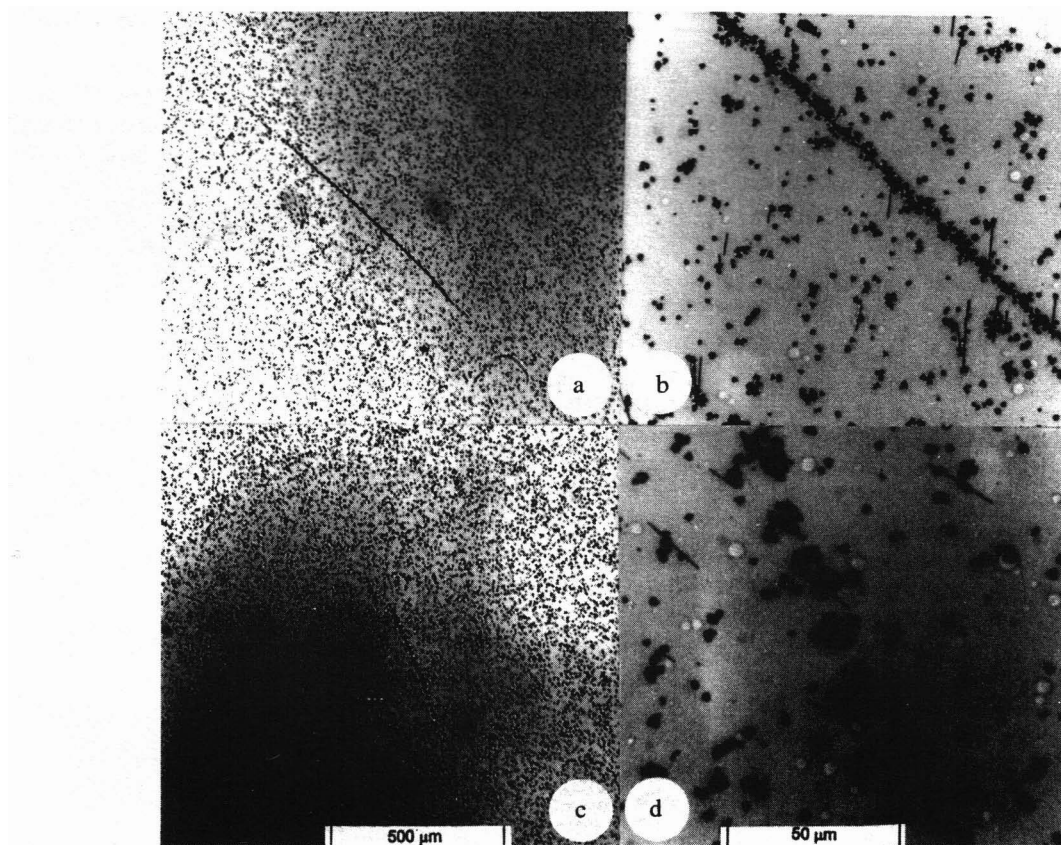

Fig. 12. (a) and (b) Alpha-particle traces that emanated from a natural thorium source.

ACKNOWLEDGMENTS

The authors wish to thank two anonymous referees who greatly improved the earlier version of the manuscript. Many thanks also to M. Valenza and S. Gumeri, for their help in starting helium analyses at the Geochemical Fluid Institute, CNR, and to V. **Marcianó**, Electronic Microscopy Laboratory, Human Anatomy Section, University of Palermo, for the **photo-**micrographs of the irradiated films.

REFERENCES

1. M. **FLEISCHMANN** and S. **PONS**, "Electrochemically Induced Nuclear Fusion of Deuterium." *J. Electroanal. Chem.*, **261**, 301 (1989).
2. Y. **ARATA** and Y.-C. **ZHANG**, "Reproducible Cold Fusion Reaction Using a Complex Cathode," *Fusion Technol.*, **22**, 287 (1992).
3. E. D. **KLEMA** and G. W. **ISELER**, "Spark-Induced Radiation from Hydrogen or Deuterium-Loaded Palladium," *Fusion Technol.*, **30**, 114 (1996).
4. G. **AGELAO**, "Fusione spontanea di gas in solidi. Il contributo dell'aria per le alte temperature," Serie "Quaderni" del Dipartimento di Ingegneria Nucleare dell'Università di Palermo (1996).
5. "Hydrogen in Intermetallic Compounds II," L. **SCHLAPBACH**, Ed., Springer Verlag, Berlin, Germany (1992).
6. T. **MATSUMOTO**. "Nattoh' Model for Cold Fusion," *Fusion Technol.*, **16**, 532 (1989).
7. M. H. **MILES**, B. F. **BUSH**, and J. J. **LAGOWSKI**, "Anomalous Effects Involving Excess Power, Radiation, and Helium Production During D₂O Electrolysis Using Palladium Cathodes," *Fusion Technol.*, **25**, 478 (1994).
8. M. K. S. **RAY** et al., "The Fleischmann-Pons Phenomenon—A Different Perspective," *Fusion Technol.*, **22**, 395 (1992).
9. D. **DAS** and M. K. S. **RAY**, "Fusion in Condensed Matter—A Likely Scenario," *Fusion Technol.*, **24**, 115 (1993).
10. A. E. **PARK**, "Some Thoughts on a Simple Mechanism for the $^2\text{H} + ^2\text{H} \rightarrow ^4\text{He}$ Cold Fusion Reaction," *Fusion Technol.*, **24**, 319 (1993).
11. J. **YANG** et al., "'Abnormal' Nuclear Phenomena and Possible Nuclear Process," *Fusion Technol.*, **25**, 203 (1994).
12. M. **RABINOWITZ** and D. H. **WORLEDGE**, "An Analysis of Cold and Lukewarm Fusion," *Fusion Technol.*, **17**, 344 (1990).
13. R. W. **KÜHNE**, "The Possible Hot Nature of Cold Fusion," *Fusion Technol.*, **25**, 198 (1994).
14. T. **MATSUMOTO**, "observation of Stars Produced During Cold Fusion," *Fusion Technol.*, **22**, 518 (1992).
15. R. K. **ROUT** et al., "Reproducible, Anomalous Emissions from Palladium Deuteride/Hydride," *Fusion Technol.*, **30**, 273 (1996).
16. C. F. **POWELL**, P. H. **FOWLER**, and D. H. **PERKINS**, *The Study of Elementary Particles by the Photographic Method*, Pergamon Press, New York (1959).
17. A. **KITAMURA**, T. **SAITOH**, and H. **ITOH**, "In Situ Elastic Recoil Detection Analysis of Hydrogen Isotopes During Deuterium Implantation into Metals," *Fusion Technol.*, **29**, 372 (1996).

Giuseppe Agelao [BS, physics, Messina University, Italy, 1956; MS, applied nuclear physics, Comitato Nazionale per le Ricerche Nucleari (CNRN), Italy, 1960] was a professor in the Department of Nuclear Engineering of Palermo University from 1962 to 1997. He is now retired. He was responsible for the radioprotection system of the nuclear reactor AGN 201 "Costanza." He was also responsible for the Laboratory of Thermoluminescence, where he still develops his experiments on fusion.

Maria Carmela Romano (BS, physics, Palermo University, Italy, 1954; MS, applied nuclear physics, CNRN, Italy, 1960) was active in research in the Department of Nuclear Engineering, Palermo University, from 1961 to 1997. She is now retired. She still develops research projects and does experimental work on fusion.

Francesco Italiano (BS, geology, Palermo University, Italy, 1981) has been a researcher in the Istituto di Geochimica dei Fluidi, Consiglio Nazionale delle Ricerche (CNR). He develops studies and experimental work on geochemistry of fluids from volcanic, seismic, and submarine areas. Since 1990, he has been responsible for the laboratory of $^3\text{He}/^4\text{He}$ and noble gas isotopic ratios.