

Anti-intruder port protection “MAC (Magnetic ACoustic) System”: advances in the magnetic component performance.

Oswaldo Faggioni, Amleto Gabellone, Reginald Hollett, Ronald T. Kessel, Maurizio Soldani

1) Oswaldo Faggioni
Istituto Nazionale di Geofisica e Vulcanologia – Via Pezzino Basso 2, 19025 Fezzano (SP), Italy
faggioni@ingv.it

2) Amleto Gabellone
Istituto per le Telecomunicazioni e l'Elettronica della Marina militare, Viale Italia 72, 57126 Livorno, Italy
amleto.gabellone@marina.difesa.it

3) Reginald Hollett
Nato Undersea Research Centre, Viale San Bartolomeo 400, 19100 La Spezia, Italy
hollett@nurc.nato.int

4) Ronald T. Kessel
Nato Undersea Research Centre, Viale San Bartolomeo 400, 19100 La Spezia, Italy
kessdel@nurc.nato.int

5) Maurizio Soldani
Istituto Nazionale di Geofisica e Vulcanologia – Via Pezzino Basso 2, 19025 Fezzano (SP), Italy
soldani@ingv.it

Abstract

In the following, we report the advances made in the development of a magnetic component for peripheral monitoring of port environments for anti-intruder systems. The project was initiated by the Office of Research and Development, COMFORDRAG, Italian Navy, in 2004, with the aim of improving the detection performance of current acoustic-based anti-intruder systems, in the vicinity of quays or the seabed or in acoustic-shadow zones behind natural or artificial objects. In the five-year period from 2004 to 2008, the system has been subjected to detection-performance tests in experiments involving divers equipped with air tanks and rebreather kits in real port environments and, at the same time, the associated signal processing has been subjected to development, to enhance detection performance. In tests involving simulated diver attacks against a vessel moored alongside a quay in the port of La Spezia, the system has been proved particularly effective by detecting 9 divers out of 9. The processing of the magnetic signal has been enhanced by implementing an amplitude threshold, as a means of filtering the

passive energy components, termed Passive Energy Cutting (PEC), that is, the elimination of components that comprise no useful information regarding diver transits. The use of PEC boosts the reliability of the system in terms of detection versus false alarm rate, as evidenced by the comparison of the ROC curves for the system with and without PEC.

Rationale

In the new world military scenario, potential terrorist action against vulnerable port facilities is of increasing concern. In this context, attacks conducted by individual divers can be particularly dangerous. In fact, divers can approach protected littoral areas by exploiting regions inaccessible to acoustic-based systems, such as acoustic shadow zones near the seabed (due to the refractive properties of the sound-speed profile), or behind obstacles (natural or man-made), or in regions of high reverberation (in the vicinity of quays), and so on. The magnetic-detection method offers a potentially interesting solution to this problem in that such regions are relatively confined in proximity to the seabed or the confines of the port or obstacles. As a result, the distance from source to sensor is limited and the likelihood of detection by modern magnetometers is high. A major problem with magnetic detection in port environments is the low signal-to-noise ratio which results from the high levels of magnetic noise. The problem is compounded by the necessity to detect a target of transitory nature such as that of a diver. The conventional approach to a solution is based on the classification of the magnetic noise components in the environment (human noise, environmental magnetic variations, magnetic field induced by waves and sea currents and so on) and on the elimination of such components by filtering. This approach leads to unreliable and subjective results, often totally dependent on the magnetic environment of the measurements and consequently unstable; if, in addition, it is required to detect low magnetic signatures such as those of a diver, the approach is entirely ineffective. In contrast, MACmag (the magnetic component of the MAC System), exploits the spatial stability of the target (diver) and noise signals, obtained from at least two magnetometers; the first (sentinel), registers both the target and the noise, the second (reference magnetometer), only the noise. If these instruments are positioned on the seabed in an appropriate geometrical arrangement (in such a way as to correlate the noise yet decorrelate the target), the reference signal can be used to remove the noise component from the sentinel's signal, to result in enhanced discernment of target transients.

The MAC System magnetic component design approach and architecture

MACmag is the magnetic component in the design of a magneto-acoustic port (and coastal) protection system for defense against divers (Fig. 1). MACmag's role is the defense of peripheral regions of ports and littoral environments in which discernment of targets by acoustic means (the principal component of defense), is obscured by physical obstacles or by refraction or reverberation.

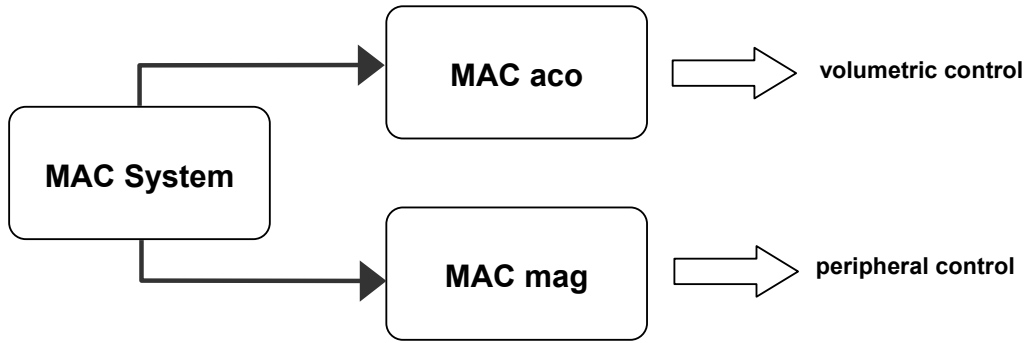

Fig. 1

The magnetic sensors available today have extremely high sensitivities and, in principle, are capable of detecting the signals caused by divers without difficulty. In practice, this prerogative is strongly compromised by the spectral content of the Earth's magnetic field in port areas which exhibits an extremely wide band with components of amplitude often exceeding that of the target. If we indicate by E_i the energy associated with the i th elementary spectral component of the magnetic field, the information content Q of the field is given by

$$Q = \sum_{i=0}^N E_i,$$

whereas, the information capacity C_i , that is, the capacity to associate an individual elementary spectral component with its physical generator, is given by the ratio of the energy E_i to the total energy in which it is dispersed

$$C_i = E_i / Q.$$

Values of C_i range from 1 (monochromatic signal), to 0 (white noise or insufficient target signal amplitude);

$$\lim_{Q \rightarrow E_i} C_i = 1; \lim_{Q \rightarrow \infty} C_i = 0; \lim_{E_i \rightarrow 0} C_i = 0,$$

in which the third condition, indicative of technological insufficiency of the sensor, is, as already stated, entirely overcome at distances in the proximity of modern magnetometers.

The effectiveness of the magnetic component of the MAC System is governed by the second of the limit conditions: in ports, we are faced with conditions of high Q and diver targets have low E , therefore, we can reasonably state that divers, even equipped with commercial respiratory kit (air tanks), are close to the limit of 0. This condition, of phenomenological type, that is, metrological and not modifiable

by numerical procedure, makes it unreliable to seek solutions based on conventional classification and filtering of the signal. Even the classical approaches aimed at amplifying the target signal are not suitable to the solution of this problem as these necessitate the identification of the signal prior to detection. However, in physical reality, in the Earth's magnetic field, the elementary magnetic signal from the target is present and, although not distinguishable from the background noise, is characteristic in terms of its amplitude, phase and wavelength. In consequence, the target signal can be isolated, to within numerical accuracy, by utilizing a magnetogram of noise (only), to filter the magnetogram of target signal with noise. In this regard, the geometrical distance between the points of observation is a critical parameter in the MACmag detection system. The distance is required to be large enough to ensure registration of the target signal in only one of the magnetograms, yet not too large, to ensure maximum correlation between the noise components in both magnetograms (Faggioni, 2005). If this condition is satisfied, then the signal comprising target and noise ($F(N+T)$) filtered by the signal comprising noise only ($F(N)$), results in a signal comprising the target only ($F(T)$). If the signals from the two magnetometers (sentinel and reference), are acquired with the same clock, then the filtering operation is a simple subtraction; in the case uncertainties in clock timing (even minimal uncertainties), the filtering operation is performed in the frequency domain (with an increase in numerical inaccuracy), (Fig. 2).

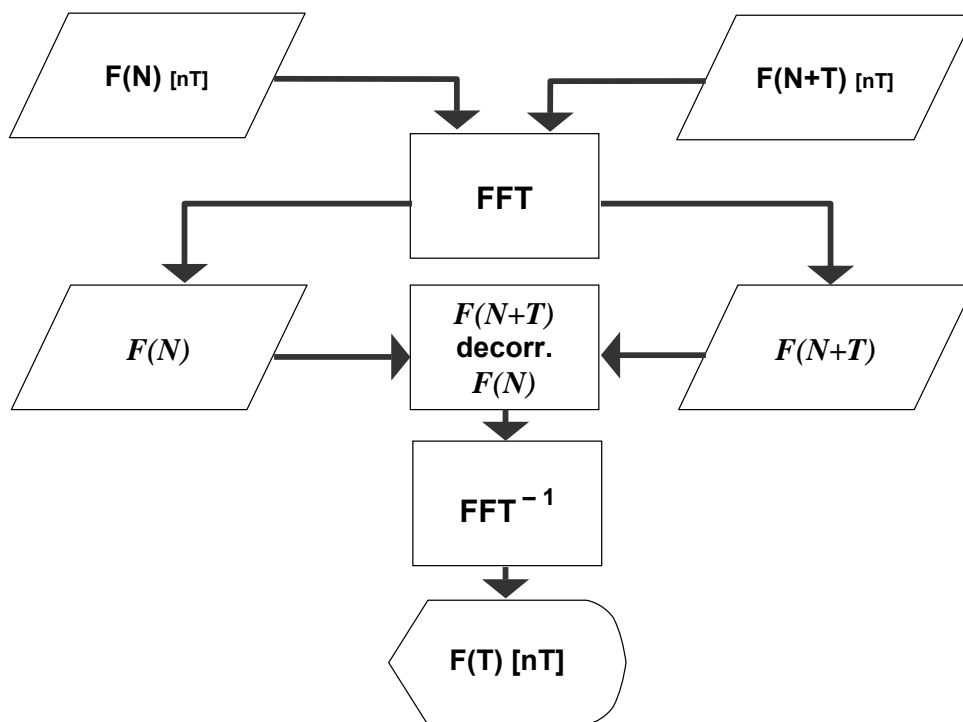

Fig. 2

This result can be obtained by two different architectures for the magnetometric system: one architecture employs the magnetogram from the preceding or

succeeding instrument in the chain as the noise reference (so that the instruments in the chain act alternately as sentinel and reference); the other architecture employs a chain of instruments with a single instrument as noise reference external to the rest (so that the instruments in the chain all act as sentinels). The first architecture is known as a SIMAN-type network (Self-referred Integrated Magnetic Network), the second as a RIMAN-type network (Referred Integrated Magnetic Network), (Gabellone et al., 2007). The system utilized in experiments to date has consisted of two magnetometers in a SIMAN arrangement; it has provided the inputs $F(N)$ and $F(N+T)$ to the flow diagram in Fig. 2. However, this arrangement does not represent a full operational unit of the SIMAN network for the simple reason that a target crossing halfway between the two sensors results in the same signal at both and consequently cancellation of the target in the filtering process. In practice, a full operational unit comprises a third magnetometer which allows comparisons between the first pair (ΔF_{12}), and the second pair (ΔF_{23}), such that cancellation of the target can occur for at most one pair only (Fig. 3).

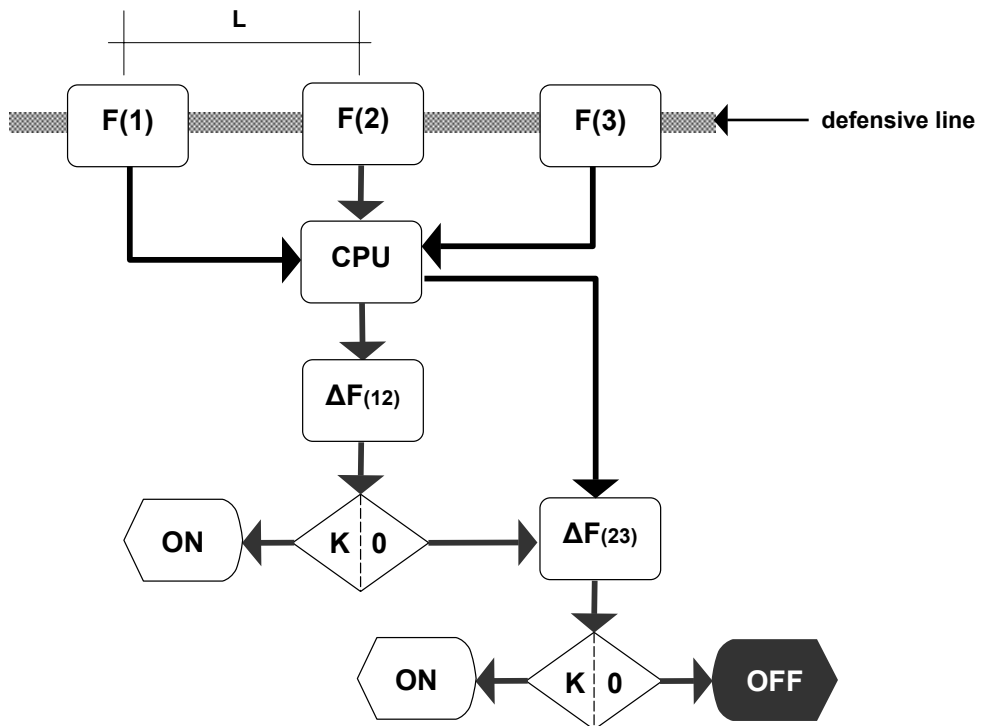

Fig. 3

The experimental arrangement utilized to date, comprising two magnetometers, is clearly suitable for experimental validation of the MACmag component, with the exclusion of target crossings halfway between the magnetometers, that is at $L/2$.

Experimental effectiveness and detection performance

We describe MACmag's detection capability in terms of results obtained in a port-protection experiment conducted under realistic conditions.

The experimental measurements were made in the harbour inlet adjacent to the NATO Undersea Research Centre (NURC), inside the port of La Spezia. NURC's Coastal Research Vessel "Leonardo" was berthed alongside the inlet's southern quay. The experimental system, comprising two magnetometers in an elementary SIMAN arrangement, was deployed to protect Leonardo against diver attack. Several attack runs were made by military divers equipped with air tanks (initially), and rebreather kit (subsequently). The divers were made to approach Leonardo from outside the inlet, keeping to acoustic shadow zones close to the seabed and the inlet's southern quay. The magnetic noise environment in the inlet was typical of port scenarios: in our case, composed of magnetic signals associated with normal urban activity, nearby shipyards, background noise associated with the electric power station "E. Montale" in the vicinity, low frequency transients generated by railway traffic and the natural activity of the Earth's magnetic field. In addition, some dozens of automobiles were parked on the quay, one with its engine running. Also, Leonardo's diesel engines were started to simulate conditions prior to departure.

The variations of the magnetic field measured by the two magnetometers during two of the diver runs (four transits, forth and back), are plotted in Fig. 4. The magnetogram in Fig. 4A shows the signal produced by the sentinel component of the magnetometer pair. This allows us to assess the detection performance of a conventional system in magnetic detection mode: the magnetic field appears to be characterized by a high level of background noise (with respect to the measurement capabilities of the magnetometers used), and shows four singularities which appear attributable to the diver transits (signals 1, 2, 4 and 5), together with a composite signal (3), possibly from a fifth transit. These observations, according to conventional procedures for magnetic detection, are summarized in Table 1, in terms of alarm ON/OFF decisions (presence/absence of diver transit).

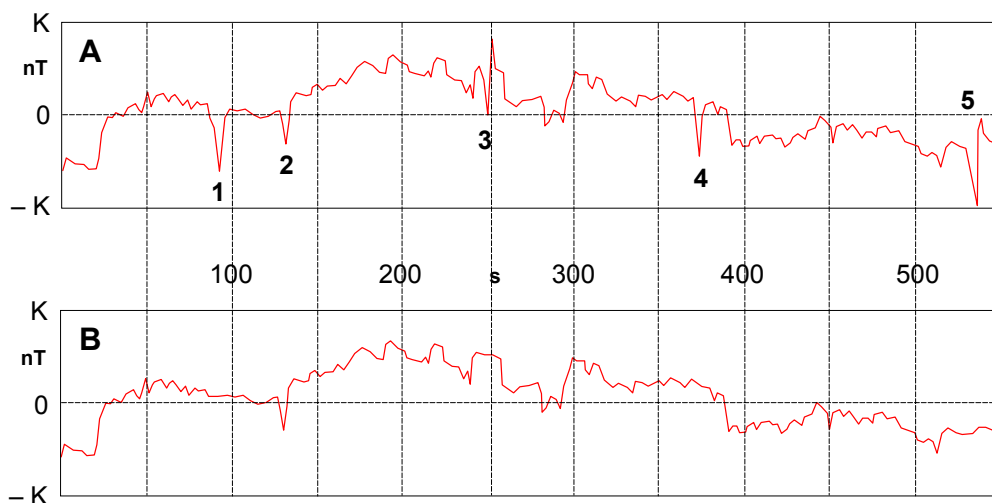

Fig. 4

Table 1 provides an assessment of the magnetic detection performance to be expected from a conventional system (that is, without a reference magnetometer to provide decorrelation filtering of the noise), and although it provides an indication of the diver transits, its effectiveness is limited (certainty of alarm is low and signal clarity is low).

N.	type	alarm
1	impulse	yes
2	impulse	yes
3	composite	human decision
4	impulse	yes
5	dipole	yes

Table 1

In brief, detections based on the observation of the form of the transitory signals leads us to declare four clear alarms and one uncertain alarm.

In contrast, MACmag not only utilizes the magnetogram of Fig. 4A as a sentinel, it also utilizes the magnetogram of Fig. 4B as its noise reference, according to the flow diagram of Fig. 2. The magnetogram of Fig. 4B was obtained from a magnetometer spaced at sufficient distance to decorrelate the diver signals yet not too distant to maintain correlation of the noise (basic requirement of the system: spatial stability of the temporal fluctuations of the field). The result of decorrelation filtering of the noise is shown in Fig. 5: the output magnetogram exhibits high-frequency background noise (due to the decorrelation filtering), of low level, together with four well-defined signals characterized by amplitudes much higher than the background level. Clearly, the detection performance of the sentinel is notably increased as a result of the extra input from the noise reference. In particular, signal 2, which is reported in Table 1 as a certain alarm (conventional system output), is absent after decorrelation filtering and therefore an environmental noise spike, whereas signal 3 which is reported as composite in Table 1 (and difficult to interpret), is enhanced after decorrelation filtering and therefore a diver transit. This increased detection performance relates directly to increased reliability in automatic monitoring of acoustic shadow zones.

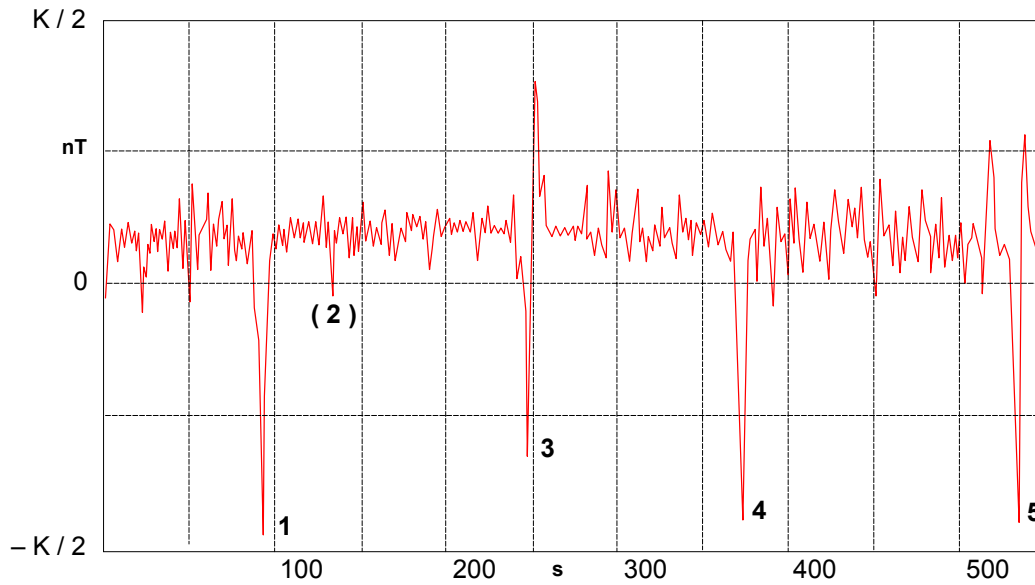

Fig. 5

MACmag's detection performance (as deduced from the output magnetogram of Fig. 5), is summarized in Table 2.

N.	type	alarm
1	impulse	yes
3	dipole	yes
4	impulse	yes
5	dipole	yes

Table 2

The comparison of the two tables indicates that the detection uncertainties associated with a conventional system based on only one magnetometer, are overcome using the technique based on a pair of magnetometers which exploits the spatial stability of the temporal magnetic signals. In particular, the SIMAN unit distinguishes four transits out of four, eliminating the false signal 2 (Table 1), and confirming the signal 3 (Table 1). It is interesting to note that the decorrelation filtering, while outputting impulse/dipole signals at the true target transits, also outputs a background of high-frequency micronoise; such noise is due to the low

spatial stability of magnetic noise at high frequency. Noise belonging to this high-frequency band is generally not correlated, even at relatively close spatial separations, and consequently passes through the decorrelation filter to sum in amplitude and phase in the filter output. This phenomenon is not of great concern as the noise amplitude is generally modest and, above all, its spectral components are much higher than those of the target signals, so that, if required, the noise can be easily controlled by an FFT-based lowpass filter (Kanasewitch, 1981).

Of further interest are some observations on the numerical behaviour of the decorrelation filter (Fig. 5):

- Suppression of signal 2

Signal 2, even though of the same form as a target signal, is suppressed in the output, owing to the fact that it is present in both input magnetograms. A comparison of the harmonic parameters of signal 2 with respect to signal 1, both before and after the decorrelation filtering, indicates that A_2 (the amplitude of signal 2), decreases from 65% of A_1 to 15% of A_1 and that λ_2 (the wavelength of signal 2), decreases from 90% of λ_1 to 5% of λ_1 . Upon close observation of the form of signal 2 in Fig. 5, we note that it includes a residual feature of modest amplitude and high frequency which makes the signal appear dipolar: we interpret this residual feature as due to a small phase error between the measured signal of the first magnetometer and that of the second. This is probably the result of measurement errors in our data acquisition system and not attributable to some physical phenomenon of electromagnetic propagation.

- Enhancement of signal 3

The form of signal 3 after decorrelation filtering (Fig. 5), is not that of a classical dipole; instead, it exhibits sharp singularities at the beginning and end of the signal. Upon close observation of the magnetograms in Fig. 4, we note that these singularities correspond to the superimposed noise components at the beginning and end of the signal which are unaffected by the decorrelation filter. This confirms the small phase error in our data sampling system which permits the noise samples to pass through the decorrelation filter at the beginning and end of the signal, at which times the noise samples are not completely coincident (Fig. 6). Clearly, this problem can be solved by ensuring that all instruments are sampled using a common clock (GPS clock).

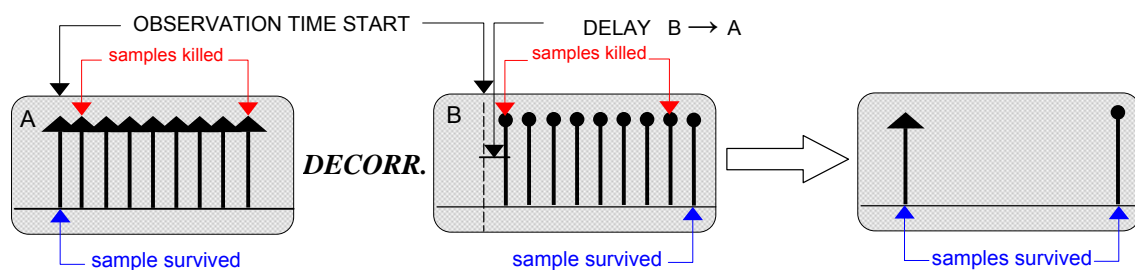

Fig. 6

In order to emphasize the performance of the MACmag system, we report the statistics obtained from observations based on a conventional magnetic-detection system (Fig. 7A), and those based on the MACmag system, that is, the concept of spatial stability of the temporal fluctuations of the field (Fig. 7B). The statistics shown include all the experiments performed to date (24 runs), and are clearly in line with the specific example cited (Figures 4 and 5).

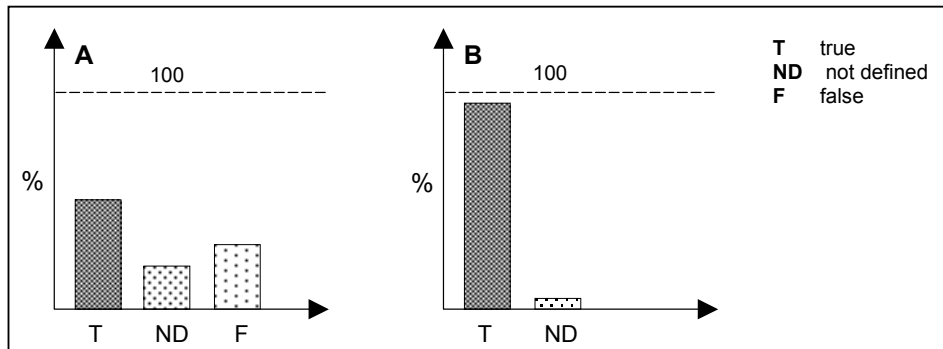

Fig. 7

In brief, for all the runs to date, the true alarm cases (T), increase from 50% of the total for the conventional magnetic-detection technique (Fig. 7A), to 95% for the MACmag technique (in SIMAN configuration), (Fig. 7B); the cases of events not defined (ND), decrease from 25 % to 5% and false alarms (F) from 30% to 0%; for the specific example cited (Figures 4 and 5), the true alarm cases increase from 60% to 100%, the cases of events not defined decrease from 20% to 0% and false alarms from 20% to 0%.

The P.E.C. amplitude filter contribution

In order to implement reliable automatic monitoring with MACmag, we have introduced an amplitude filter, designed to eliminate passive energy (or that considered passive from our point of view), present in the decorrelation filter output magnetogram. The objective of the design is the elimination of the high-frequency micronoise; prior to the actual filtering, the signal is treated for stabilization.

- Signal stabilization

The magnetic signal registered in zones of high noise can be subjected to measurement/numerical discontinuities which, in effect, interrupt the information flow. Such discontinuities, generally attributable to the technical characteristics of the instruments employed, are essentially of three types: instrument saturation, spikes, instrument unlocking. These phenomena alter the information flow and can confuse the data registration and interpretation system with fatal consequences for MACmag. Stabilization of the signal in the presence of these phenomena is therefore essential and we report the steps taken

to address the problem (prior to application of the P.E.C. filter). In discussion of the steps taken, we refer to data registered during the experiment ‘CF05EX-II’, conducted by NURC from an offshore islet (Island of Palmaria, Italy), with divers carrying commercial air tanks, in average noise conditions (Fig. 8).

The phenomenon of instrument saturation is due to the finite precision of the data sample representation in memory, in our case 16 bits (1 sign bit plus 15 data bits), which implies, in terms of the measured field, a maximum value of ± 400 nT. Beyond this limit, the measurement instrument is subject to discontinuities termed overflow/underflow (Fig. 8A)

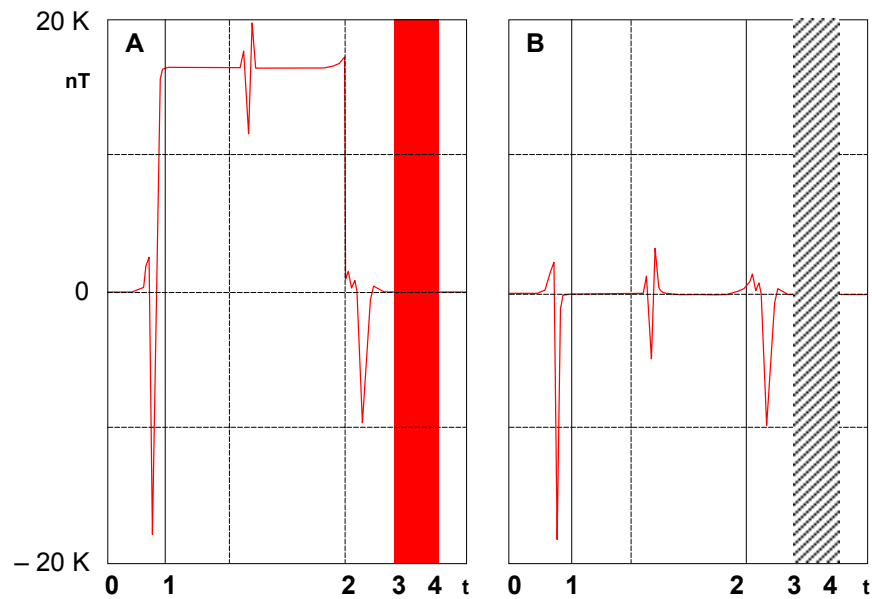

Fig. 8

Instrument saturation often occurs in the presence of quasi-static sources in proximity to the sensor: in our case the situation occurred by moving CRV Leonardo close to the operating zone. Despite this, the measured field, in terms of the fluctuations about the average, still makes sense (segment 1 to 2, Fig. 8A). The problem of recovering saturated segments of data is solved by subtracting the average during saturation, estimated by comparison with averages from neighbouring unsaturated segments (before and after each saturated segment). In the case of the saturated segment in Fig. 8A, the average during saturation from 1 to 2, is estimated from the averages in the segments from 0 to 1 minus δt and from 2 plus δt to 3, for a sampling interval δt . The onset and duration of saturated segments are estimated by determining and thresholding the sample-to-sample gradient. In practice, a sliding window of 100 samples is passed sample-by-sample over the data series and if discontinuities of length greater than 50 samples are detected then the average

is subtracted. In the case of the saturated segment of Fig. 8A, the result of this processing is shown in Fig. 8B.

The problem of spikes occurs on brief occasions ($\Delta t < 10\delta t$, or approximately 0.2 s of acquisition time), in which the instrument outputs spurious values. Such phenomena are often associated with high values of the temporal gradient of the field:

$$(dF / dt)\delta t > \text{DMC (Device Measurement Capacity)}.$$

In the case of the data shown in Fig. 8A, a sequence of spikes occurs in the segment 3 to 4, generated by moving a rubber boat, with outboard motor running, close to the instrument. The samples output during occurrences of spikes are devoid of physical significance and are eliminated. The occurrence of spikes is detected by determining and thresholding the gradient. In the case of single, well-isolated spikes, the eliminated samples are directly substituted by the samples occurring immediately prior to the spikes. In the case of long sequences of spikes, uninterrupted by segments of real data sufficient to enable direct substitution, the solution is provided by synthetic reconstruction of the signal (Faggioni et al., 1991). This technique is based on isolating the low-frequency band and its associated (slowly-varying) time series, represented at a reduced sampling rate, such that the sampling interval corresponds to the length of the sequence corrupted by spikes plus $2\delta t$, centred on the sequence (Fig. 9).

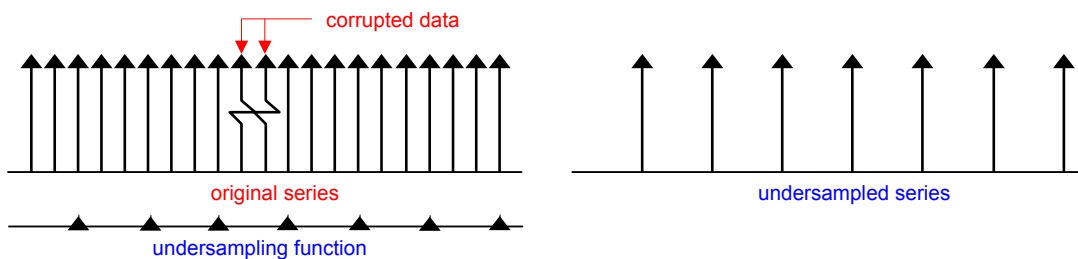

Fig. 9

The time series, created in this way, is used to reconstruct the low-frequency variation in the sequence corrupted by spikes. The high-frequency variation in the corrupted sequence is reconstructed by superposition of the high-frequency variation in the data immediately prior to the sequence, obtained by highpass filtering.

- P.E.C. filter (Passive Energy Cutter)

The term “passive energy” refers to that part of the energy present in the signal which bears no relevant information regarding the source to be detected (diver target). Analyses of magnetic recordings made in port areas confirm that passive-energy components with the same wavelength as those from divers, can occur in the vicinity of one or other of the sensors for reasons which are not easily identified (artificial and/or natural). These components are of lesser

amplitude than those of the target signal which generally exceed values of 2 to 4 nT, even for respiratory equipments with low magnetic signatures. The problem can therefore be addressed by applying an amplitude threshold to the spectral components, termed Passive Energy Cutter or P.E.C. filter (Fig. 10).

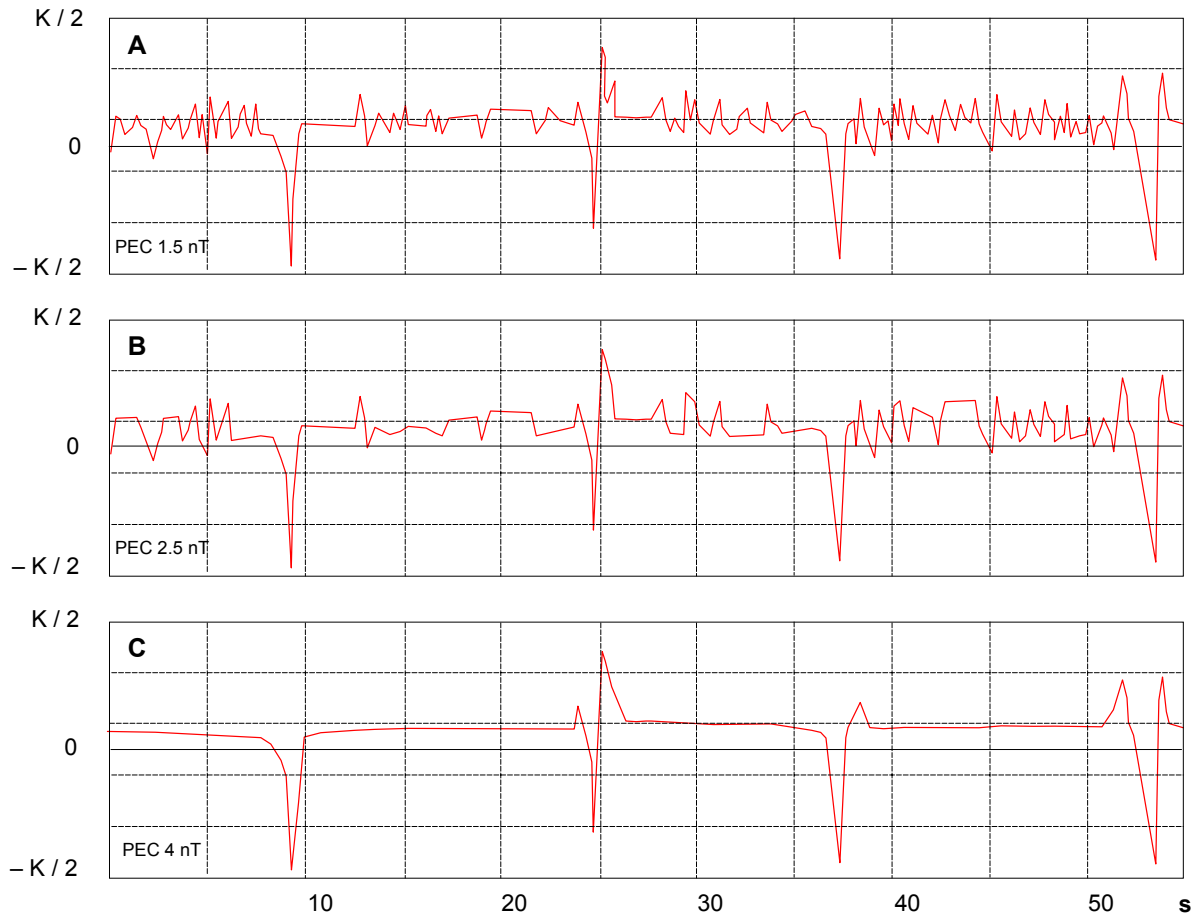

Fig. 10

In practice the P.E.C. filter eliminates all spectral components with amplitudes less than the specified threshold setting by substituting the component values with zero. The P.E.C. filter introduces flexibility into the system in that the operator has the option to raise the threshold setting to obtain increased stability in the output (Fig. 10). Consequently, the system can be adjusted, in terms of the signal-to-noise ratio in the decorrelated magnetograms, to take into account variations in environmental noise (location, time), and target characteristics (equipment, tactics). The effect of increasing the threshold setting in the P.E.C. filter is shown in Fig. 10 for various settings: Fig. 10A, P.E.C. filter response for a setting of 1.5 nT; fig. 10B, for a setting of 2.5 nT; Fig. 10C, for a setting

of 4 nT. The effectiveness of introducing the P.E.C. filter is best expressed in terms of the Receiver Operating Characteristic (R.O.C.), of the system with and without the filter (Fig. 11).

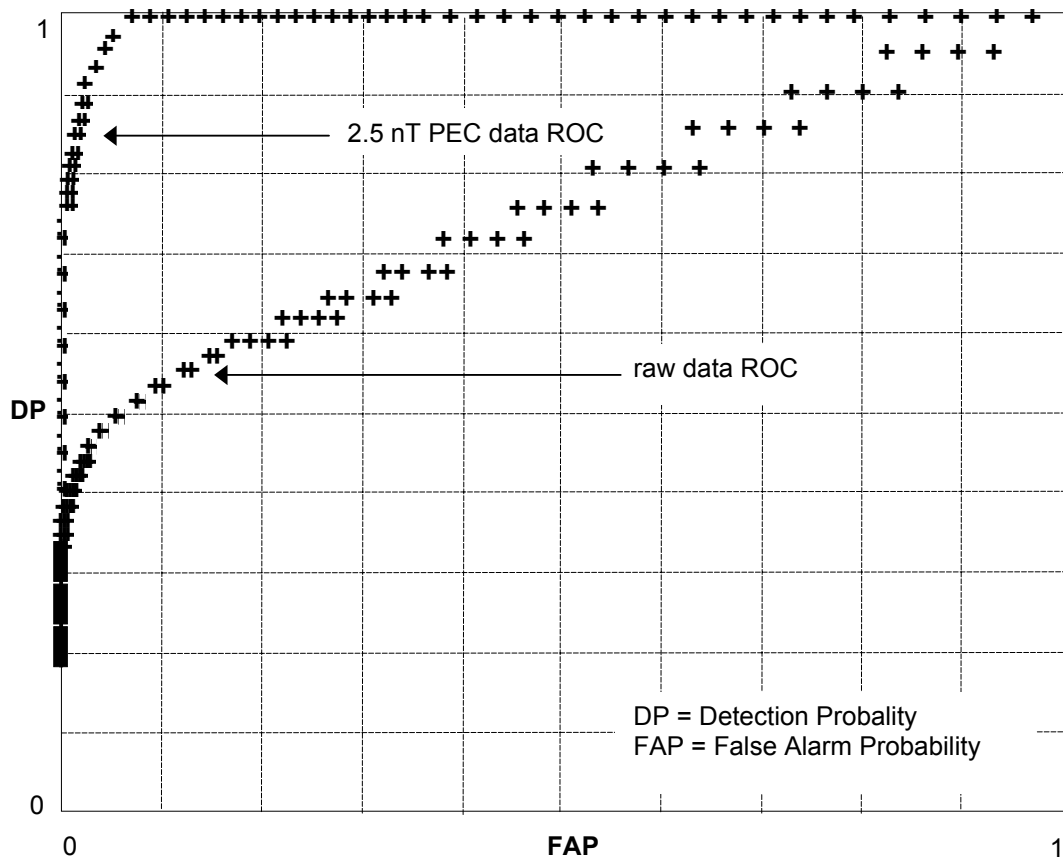

Fig. 11

Fig. 11 clearly demonstrates that the characteristic of the MACmag system, while already good without the filter, becomes excellent with the filter inserted (P.E.C. threshold set to 2.5 nT). In fact, the characteristic with the filter approaches the ideal case of a curve comprising two straight lines, $FAP = 0$ and $DP = 1$, that is, fully separated signal and noise distributions. This characteristic emphasizes MACmag's potential for operational effectiveness in terms of an automatic monitoring and alarm system.

With further regard to the use of the P.E.C. filter, a close examination of Fig. 10 reveals that, particularly at the upper threshold setting (4 nT), the output magnetogram exhibits the tendency to drift away from the zero. In order to avoid this leading to eventual saturation over extended periods of registration,

we have introduced a simple filter to check for minimal gradients and eliminate any drift from zero (Fig. 12A).

Current and future efforts

With a view to current efforts, we mention a processing technique to make the system amenable to operators with little or no experience in signal analysis. In brief, signals arising from detected target transits are replaced by vertical impulses at the times of transit (Fig. 12B).

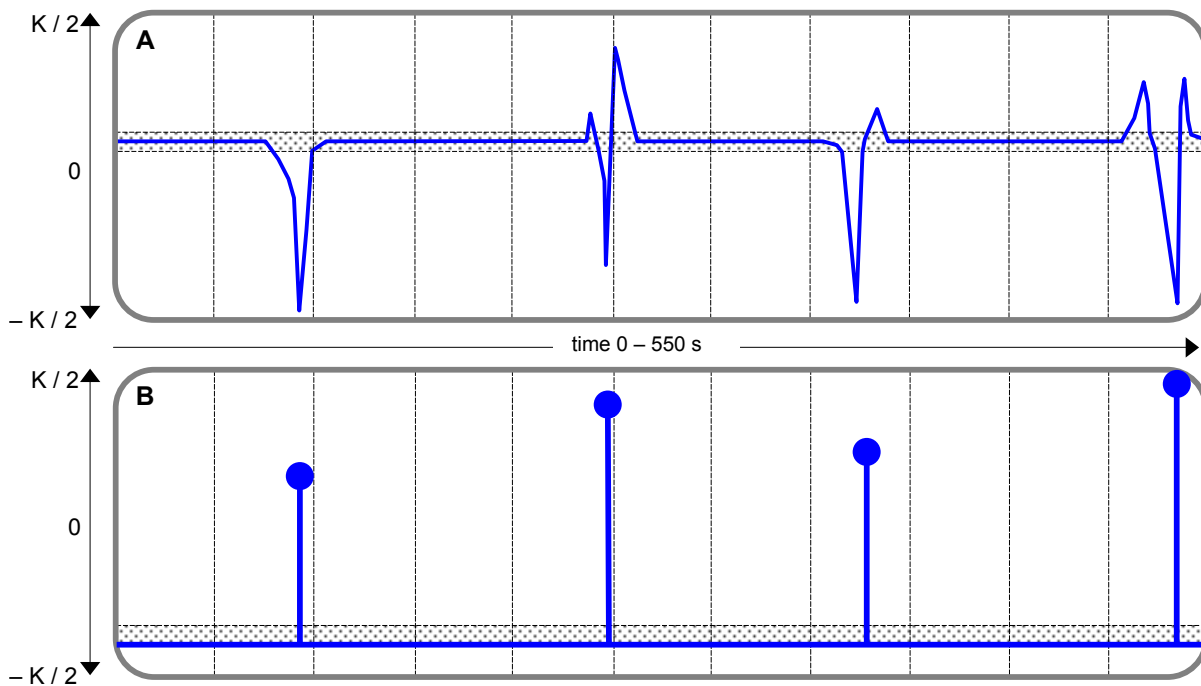

Fig. 12

In Fig. 12B (operator display), the heights of the impulses represent the absolute values of the signal amplitudes and the times of occurrences of the impulses represent the times at the signal peaks, in the case of impulsive signatures, or the times of zero crossings, in the case of dipole signatures. In addition to providing a simplified operator display, these impulse representations provide the basic information for vector tracking of the intruder, currently under development as a future enhancement of the MACmag system.

Conclusions

The application of analysis techniques to the spatial stability (coherence), of the temporal fluctuations in underwater magnetic fields has made magnetic detection by seabed networks of magnetometers a practical option and has notably increased the sensitivity of magnetic systems for undersea defense. Experimental tests carried out on the MACmag system, in undersea environments with high magnetic noise, have

emphasized its effectiveness in detecting divers transiting in proximity, both in the case of divers equipped with commercial air tanks and in the case of rebreathers. The introduction of the signal stabilization technique termed Passive Energy Cutting (P.E.C.), has led to a further enhancement of system reliability, which in all of the experiments performed, has approached 100%. False alarm rates, which in the case of conventional (classical), magnetic detection systems, have proven to be an insurmountable problem in the area of port protection, have been reduced practically to zero. Even the cases of uncertainty have been reduced to only 5% of all true detections. These results allow us to accept the actuation of a system alarm even in the rare cases of uncertainty since MACmag's false alarm rate is so low.

In brief, in the context of antiterrorist systems of the MAC class, the MACmag component is required to supplement the acoustic component in peripheral acoustic shadow zones close to the seabed, port confines and so on. In this regard, MACmag has provided extremely positive operational results. On the basis of experimental testing, in its current configuration, the system has met its objectives, in terms of intruder detection performance, robustness against noise and reliability.

References

1. O. Faggioni, P. Palangio, E. Pinna, *Osservatorio Geomagnetico Stazione Baia Terra Nova (Antarctica): Ricostruzione Sintetica del Magnetogramma 01.00(UT)GG1.88:12.00(UT)GG18.88*, Atti X Conv. Gr. Naz. Geof. Terra Solida, pp. 687-706, Roma 1991.
2. O. Faggioni; *Protocollo Operativo CF05EX*, COMFORDRAG Italian Navy, La Spezia 2005, I.N. classified.
3. A. Gabellone, O.Faggioni, M.Soldani, P.Guerrini, *CAIMAN Coastal Anti Intruders Magnetic Network*, XX UDT Europe Conference, Naples 2007.
4. A. Gabellone, O. Faggioni, M. Soldani, P. Guerrini, *CAIMAN (Coastal Anti Intruder MAGnetometers Network)*, RTO-MP-SET-130 Symposium on NATO Military Sensing, Orlando, Florida, USA, 12-14 March 2008, NATO classified.
5. E.R. Kanasewich, *Time Sequence Analysis in Geophysics*, The University of Alberta Press, Canada, 1981.