

# Solar panel simulator

Giovanni Romeo and Giuseppe Urbini

*Istituto Nazionale di Geofisica e Vulcanologia  
Roma, Italia*

This is a funny kind of power supply, not stable in voltage or in current: it simulates the comportment of a solar panel and can be very useful if you are playing around a solar powered device in a raining day. We designed it for internal use, but it may have a general value. We may roughly schematise a solar panel with the equivalent circuit shown in figure 1.

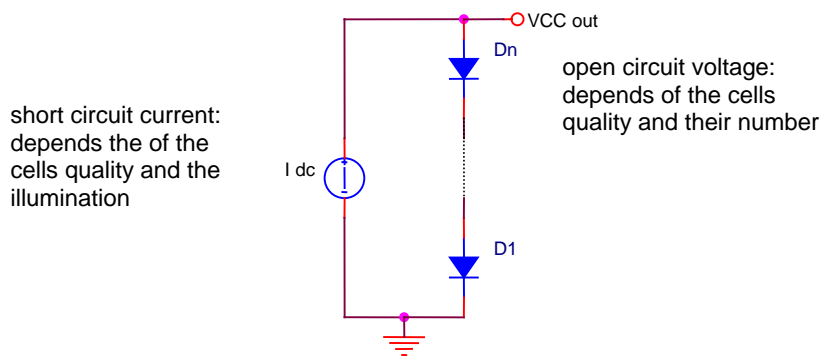

Fig. 1: Solar panel equivalent scheme. The current produced depends of the illumination and of the nature of the cells (surface, material, geometry) and the voltage is tied also to the number of cells.

There is a simple way to ‘boost’ a generator saving its I-V characteristic: it’s shown in fig 2.

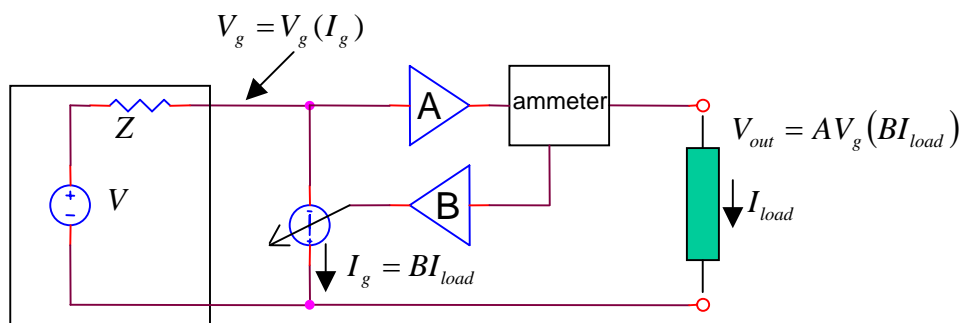

Fig 2: a generator booster. The output is transferred to the out using an amplifier (A), and the current through the load is measured and used to control the reference generator current through the scale factor B. This circuit saves the I-V generator shape, supplying the power defined by the scale factors A and B.

You may tune the values of A and B to obtain the wanted output using the I-V shape of the reference generator.

The schematic in fig. 3 is the designed to work simulator, obtained by a generator (like the one in Fig. 1) boosted following the principle illustrated in fig. 2.

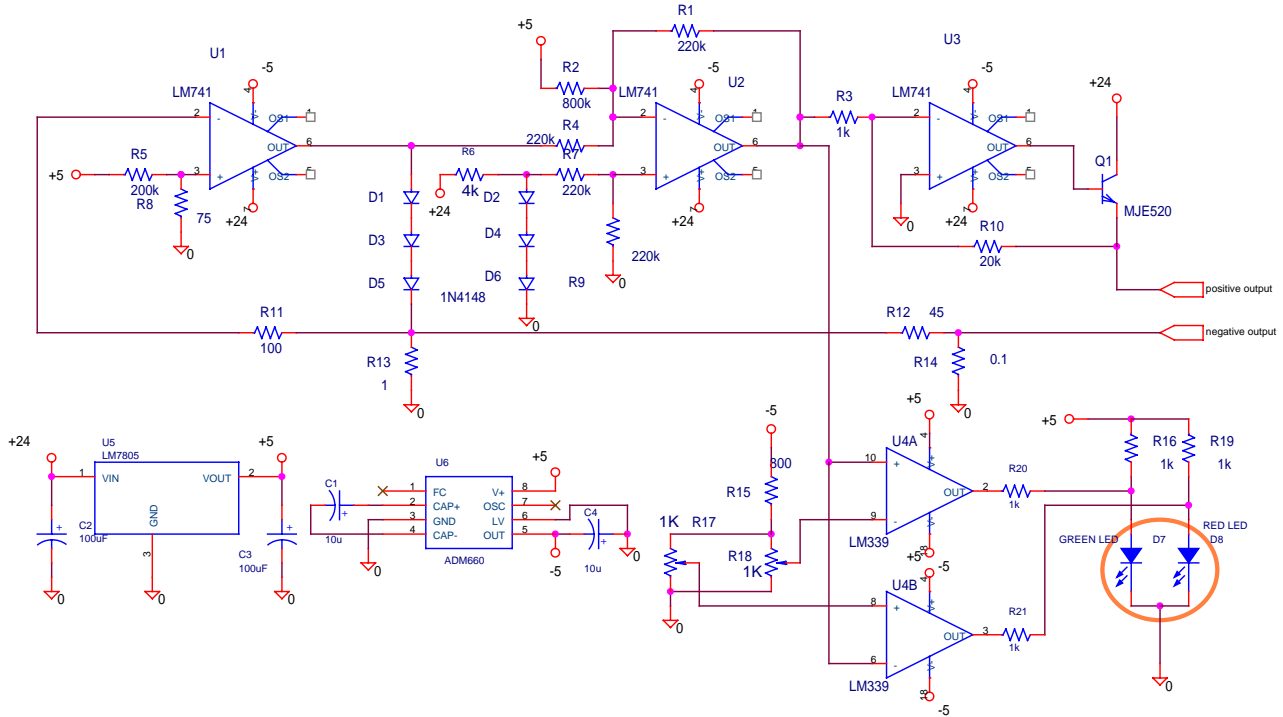

Fig. 3. The simulator designed to work. The circuit is 24 volts powered (bubble +24 and analog ground), using a floating power supply (we used a DC-DC converter). The output is between 'positive output' and 'negative output'.

U1 is used as current generator, and the constant current, flowing through a series of diodes (D1, D3, D5) is obtained by reading the shunt R13; the diodes and the constant current source form the reference generator (as shown in fig.1). D2, D4, D6 and U2 operate a temperature correction. U3 and Q1 (fig. 3) are used as output amplifier. The information about the load current is obtained by the shunt R14. Both of the shunts, R13 and R14 work in the low side; this is not elegant but, since a solar panel is a floating device, you need to power the whole circuit with a floating voltage source, and the low side shunts work perfectly. The number of cells (open circuit voltage) is obtained changing the output gain modifying the R10 value (A gain in fig.2); the resistor R12 regulates the short circuit current ( $I_{dc}$  in fig. 1) by changing the B gain (fig. 2). Op amps are not critical, and many modern quad op amps may replace the old beloved 741.

The circuit shows the power coupling conditions using a two-colours LED. It lights green when the load is too weak, red when it is too heavy, and orange when it approaches the maximum power transfer, indicating that your load is well coupled with the simulated panel. This is useful to quickly check MPPT charge regulators.

This LED is operated by a couple of comparators (U4 A and B) looking at the voltage of the diodes series. This is done after the thermal correction.

Fig.4 shows the simulator compartment, the blue curve is the typical V-I curve of a solar panel.

The orange curve represents the power output. The traces red and green represent the LED status.

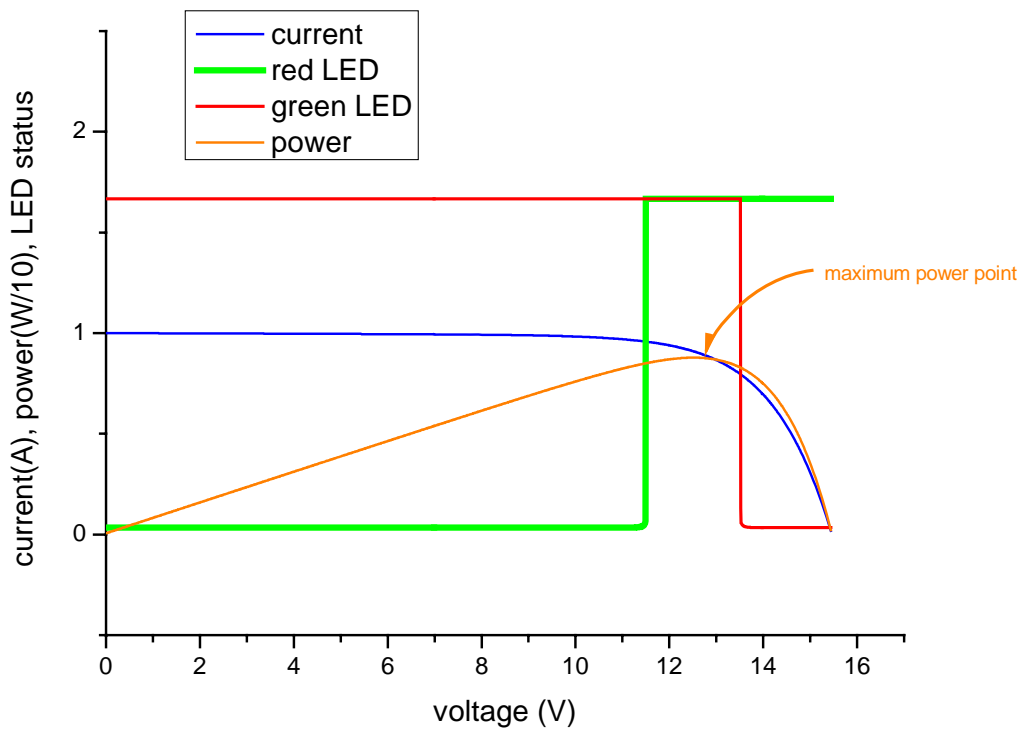

Fig. 4: Simulator compartment. The blue trace shows a typical I-V curve of a solar panel; red and green traces show the LEDs actions. The light is green in case of weak load (low current, high voltage), red in case of heavy load (high current, low voltage) and orange (both LEDs on) around the MPP. The LEDs thresholds can be tuned using R17 and R18 in Fig. 3. The orange trace represents the output power.