

|             |   |
|-------------|---|
| Title       | Beam Control Technologies With a High-Efficiency Phased Array for Microwave Power Transmission in Japan   |
| Author(s)   | Shinohara, Naoki  |
| Citation    | Proceedings of the IEEE (2013), 101(6): 1448-1463   |
| Issue Date  | 2013-06   |
| URL         | <a href="http://hdl.handle.net/2433/174333">http://hdl.handle.net/2433/174333</a>   |
| Right       | © 2013 IEEE. Personal use of this material is permitted. Permission from IEEE must be obtained for all other uses, in any current or future media, including reprinting/republishing this material for advertising or promotional purposes, creating new collective works, for resale or redistribution to servers or lists, or reuse of any copyrighted component of this work in other works. |
| Type        | Journal Article   |
| Textversion | author  |

# Beam Control Technologies with a High Efficiency Phased Array for Microwave Power Transmission in Japan

Naoki Shinohara

Research Institute for Sustainable Humanosphere, Kyoto University

**ABSTRACT** — Beam control and/or beamforming technologies involving phased arrays can be used to enable highly efficient microwave power transmission (MPT) systems. In Japan, several field MPT experiments using a phased array were conducted over the years. In 1992, a joint collaborative group successfully conducted a fuel-free flight experiment using phased array technology, which was referred to as the Microwave Lifted Airplane eXperiment. In 2008, Kobe University and a US research group successfully conducted a MPT experiment using a phased array that resulted in power transmission over a distance of 150 km. Furthermore, Kyoto University proposed and demonstrated a magnetron-based phased array and conducted MPT from an airship to the ground in the spring of 2009. In FY2010, Kyoto University developed new highly efficient phased arrays for MPT and Solar Power Satellites. This study provides an overview of past and present Japanese MPT experiments using phased array technologies.

**Index Terms** — Microwave Power Transmission, Wireless Power Transmission, Phased Array, Antenna, Retrodirective, DOA

## I. INTRODUCTION

A microwave frequency band is suitable for wireless power transmission (WPT) because of the following reasons:

- 1) Microwave technologies are well developed, efficient, and cost effective in comparison with those operating at higher frequencies.
- 2) System size, particularly antenna size, is smaller than systems operating at lower frequencies.
- 3) There are reduced power losses owing to less absorption and diffusion by air and rain when compared to millimeter wave and terahertz frequencies.

In fact, the first WPT, conducted by W.C. Brown in the 1960s, owed a large portion of its success to the highly developed nature of microwave technology. Wireless power was concentrated for the first time to a receiving target via 2.45-GHz-band microwave radiation [1].

On the basis of radio wave theory, the beam efficiency  $\eta$  between transmitting and receiving antennas can be calculated by the following equations:

$$\tau^2 = \frac{A_t A_r}{(\lambda D)^2} \quad (1)$$

$$\eta = \frac{P_r}{P_t} = 1 - e^{-\tau^2} \quad (2)$$

where  $P_r$ ,  $P_t$ ,  $G_r$ ,  $G_t$ ,  $A_r$ ,  $A_t$ ,  $\lambda$ , and  $D$  are received power, transmitted power, antenna gain of the receiving antenna, antenna gain of the transmitting antenna, aperture area of the receiving antenna, aperture area of the transmitting antenna, wave length, and distance between the transmitting and receiving antennas, respectively. Two confronting aperture antennas are assumed in these equations. They indicate the beam efficiency in the near field. Equation (1), itself, indicates the efficiency in the far field on the basis of the Friis equation. These equations indicate that higher frequencies realize higher beam efficiency under otherwise identical conditions. These equations also indicate that transmission distance increases with frequency for a given efficiency under otherwise identical conditions. In contrast, efficiency of circuits, semiconductors, and tubes decrease with increasing frequency. Owing to these considerations, microwave frequencies are presently most suitable for long distance WPT. Other types of WPT, such as inductive coupling and resonance coupling, cannot theoretically be applied over a long distance WPT.

However, if we design microwave power transmission (MPT) systems based on the wireless communication system approach, microwave beam power and efficiency tends to be much larger and smaller, respectively, than what users actually require. For example, the Goldstone MPT experiment conducted at 2.388 GHz in 1975 used a 26-m diameter parabolic antenna [2] placed 1.54 km away from a  $3.4 \text{ m} \times 7.2 \text{ m}$  rectenna array. The overall efficiency of the transmitted microwave power from the parabolic antenna to DC power on the rectenna array was only 6.7% (30-kW DC delivered with a 450-kW beam power), which included an 82% RF-DC conversion efficiency of the rectenna array. The transmission efficiency of the Goldstone experiment was poor and the system size was larger than that required for wired power transmission.

The other merit of MPT is that power can be transmitted to moving targets using microwave beamforming techniques. In this manner, it is easy to change the beam direction to accommodate moving targets using phased array techniques without any motion of the transmitting antenna. This suggests that wireless microwave power can be transmitted to/from moving targets with high-beam efficiency. In the 1960s and 1970s, MPT experiments were conducted using parabolic or horn antennas. Such systems were unable to change the beam direction without physically changing the antenna direction. However, for a Solar Power Satellite (SPS) designed at the end of 1970s by National Aeronautics and Space Administration, Department of Energy, and Raytheon in the US, a phased array was adopted to control the microwave beam direction [3]. Phased arrays for MPT were mainly

developed for SPS applications. From the 1980s, SPSs were designed by Japan Aerospace Exploration Agency (JAXA) and The Institute for Unmanned Space Experiment Free Flyer, presently J-Spacesystems / Ministry of Economy, Trade, and Industry (USEF/METI), the efforts of which were supported by many universities and companies. Recent concept designs of SPS systems in Japan are shown in Fig. 1. Figures 1(a) and (b) show a basic microwave-type model SPS and an advanced microwave-type model SPS, respectively [4]. As a result, SPS applications have driven the development of phased array technologies.

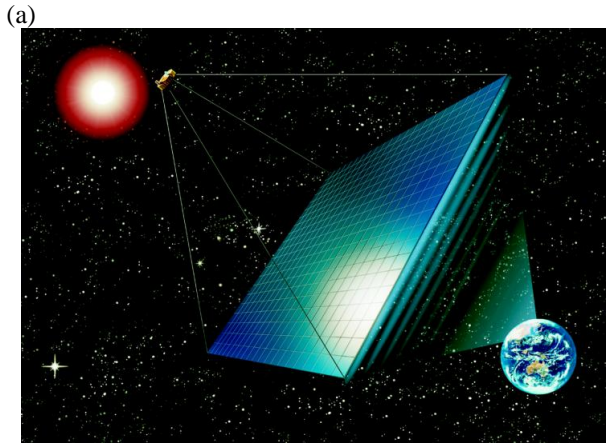

(a)

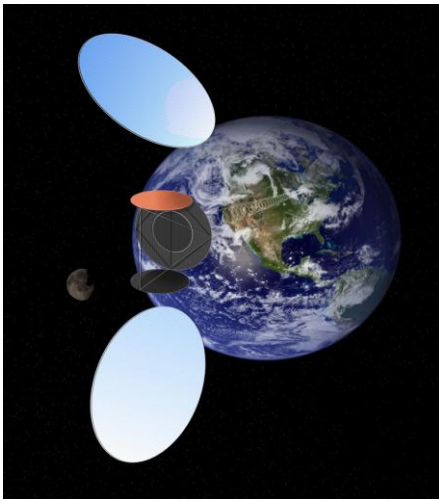

(b)

Fig.1 Recent concept designs of SPS in Japan. (a) Basic microwave-type model SPS, and (b) Advanced microwave-type model [4]

Phased arrays are typically used for radar or remote sensing. For example, a phased array in the S-band, which was composed of 4,000 phased shifters/arrays and 936,000 manufactured elements, is used for the AEGIS radar system [5]. A Japanese group, whose members include the National Institute of Polar Research, the University of Tokyo, Kyoto University, many other universities, national institutes, and companies, is building a Mesosphere/Stratosphere/Troposphere (MST) radar/incoherent scatter (IS) radar in the Antarctic to measure atmospheric phenomena. This project is called the Program of the Antarctic Syowa MST/IS Radar. This project includes approximately 1,000 antenna elements

with a center frequency of 50 MHz and a diameter of approximately 160 m.

We know that the beam direction of a phased array can be controlled. However, the compatibility of high-efficiency beamforming of MPT is very difficult. In Japan, MPT experiments using phased arrays were conducted in 1990s and in the 21<sup>st</sup> century. Phased array with semiconductors for MPT applications in Japan are described in Section 2, which were developed for the MICrowave Lifted Airplane eXperiment (MILAX) and International Space Year-Microwave Energy Transmission in Space (ISY-METS) experiments conducted in the 1990s. JAXA's SPS demonstrator, USEF/METI's active integrated antenna (AIA) system, and cooperative works between Mitsubishi Electric Corporation and Kyoto University are described in Section 3. In Section 4, a magnetron phased array, which was developed in Kyoto University, is described. Retrodirective target detection techniques using radio waves are essential elements in MPT. Japanese trials using phased arrays and retrodirective target detecting systems are described in Section 5.

Each phased array project was independent, adopted the latest technologies, and had its own research target, for example, to fly a fuel-free airplane using MPT, to develop the thickest phased array, or to develop a magnetron phased array. The basic trends in phased array development are shown in Fig. 2. The keywords describing these efforts are "higher frequency," "higher efficiency," and "larger size and lightweight."

## II. PHASED ARRAYS IN 1990's

In 1983, Kyoto University's group in Japan conducted the first successful MPT rocket experiment called the Microwave Ionosphere Nonlinear Interaction eXperiment (MINIX). The experiment yielded new plasma data and theories about the nonlinear interaction between high-power microwave beams and ionospheric plasmas [6]-[8]. For the MINIX project, a cooker-type magnetron and waveguide antenna was used to transmit the 2.45-GHz microwave signal from the mother transmitter rocket to the daughter receiver rocket. Ten years later, the next rocket MPT experiment was called the ISY-METS and was conducted by Kyoto University, Kobe University, Texas A&M University from the US, Communication Research Laboratory (CRL), presently known as the National Institute of Information and Communications Technology (NICT), and the Institute of Space and Astronautical Science (ISAS). This second experiment included a phased array with the objective of describing detailed plasma physics. Data about the angle between the magnetic field and excited plasma wave were required to calculate the amplitude of the excited plasma wave, which is caused by the high-power microwave beam. The study also required that the microwave power be concentrated to a narrow area in order to estimate the angle between the magnetic field and excited plasma wave. Phased array technology was well suited to control the microwave beam direction and calculate the angle between the magnetic field and excited plasma wave. The magnetic field could be measured in the rocket experiment. The microwave beam direction was estimated by the beam control data together with experimental data about beam direction collected before the rocket experiment.

## Semi-Conductors

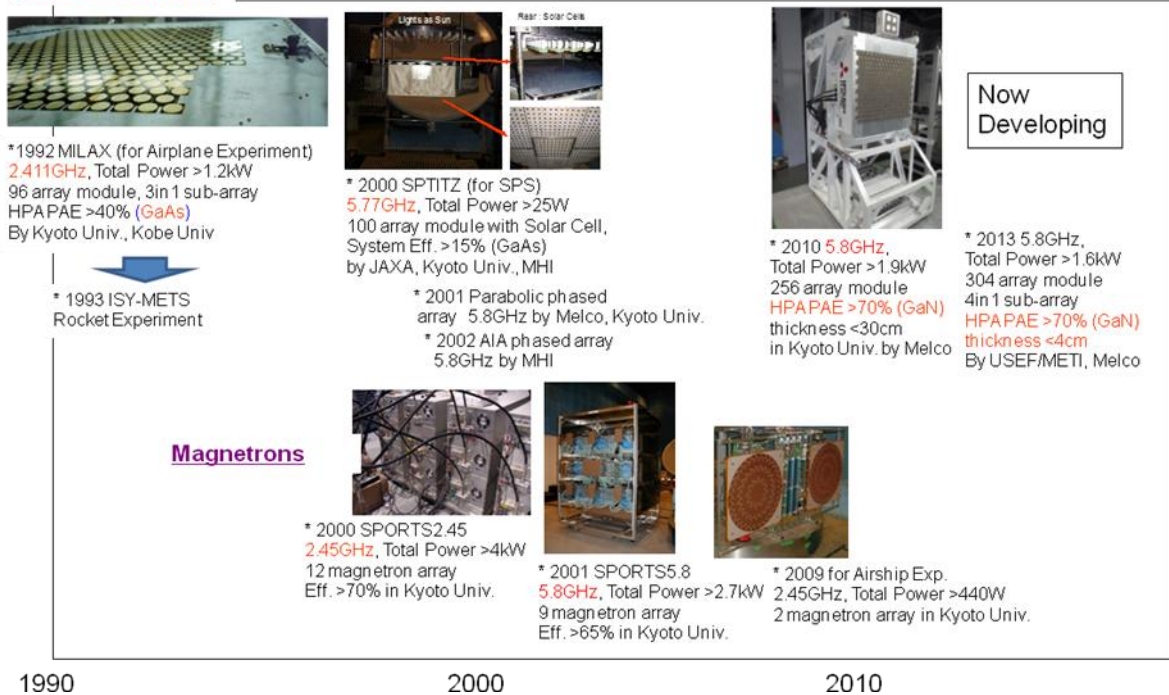

Fig.2 Schematic diagram illustrating the history of phased array technology in Japan

Shortly before the ISY-METS experiment, the fuel-free airplane experiment called the MILAX was conducted in August 1992 [9]. The phased array developed for ISY-METS was used to transmit the microwave power for the MILAX. In total, 96 GaAs semiconductor amplifiers and 4-bit digital phase shifters were connected to 288 antenna elements at 2.411 GHz. This indicates that there were three antennas for every amplifier sub-array (Fig. 3). The diameter of the phased array was approximately 1.3 m. The measured beam pattern is shown in Fig. 4. The beam width was approximately 6 degrees. The gain of the amplifier was 42 dB at 0 dBm input. Output power was approximately 42 dBm (Fig. 5). The power added efficiency (PAE) of the amplifier was approximately 40%. The total microwave power was 1.25 kW and consisted of a continuous wave (CW) with no modulation. The measured power density is shown in Fig. 6.

The phased array was assembled on the roof of a car. The car drove under the fuel-free airplane as much as possible, and the microwave beam was directed toward the fuel-free model airplane using a computer and data from two CCD cameras, which detected the position of the target (Fig. 7). One of the CCD cameras is shown on the right side of Fig. 3. The rectenna array on the airplane's body is shown in Fig. 8. There were 120 rectennas in all. The element spacing was  $0.7 \lambda$ . The efficiency of the rectenna was approximately 61% at 1-W output DC power. The airplane flew freely using only the microwave power that was delivered by the phased array. The airplane flew at approximately 10 m above ground level. The maximum DC power obtained from the rectenna array was approximately 88 W and sufficient to fly the airplane. This was the first MPT field experiment in the world that used a phased array.

However, before and after the MILAX, two MPT experiments were conducted to supply microwave power to a flying target that did not use a phased array system. The

experiment conducted previously in 1987 was called the Stationary High Altitude Relay Platform experiment by the Communication Research Centre in Canada. The researchers transmitted a 2.45-GHz, 10-kW microwave to a flying model airplane having a total span of 2.9 m, a wingspan of 4.5 m, and flying more than 150 m above ground level. The later experiment was called the Energy Transmission toward High-altitude long endurance airship Experiment (ETHER), and was conducted by Kobe University and CRL in 1995. The researchers transmitted a 2.45-GHz, 10-kW microwave to an airship flying 35–45 m above ground level. In both experiments, a parabolic antenna MPT system with a microwave tube was adopted.



Fig.3 First phased array used for a MPT application for the MILAX in 1992

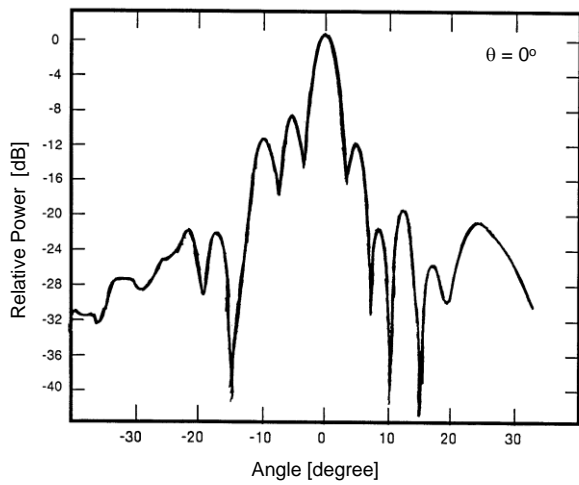

Fig.4 Beam pattern created by the MILAX phased array

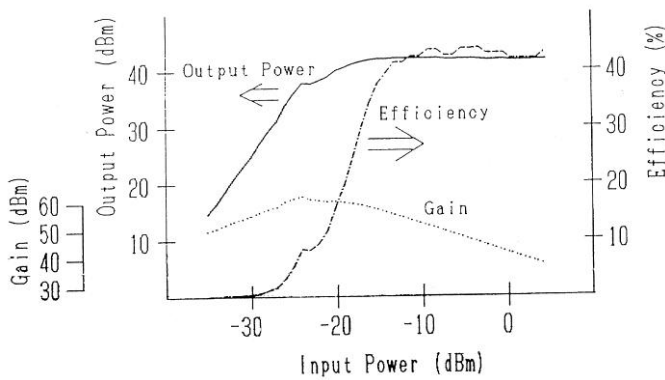

Fig.5 Measured output power, efficiency, and gain of the GaAs amplifiers used for the MILAX and ISY-METS

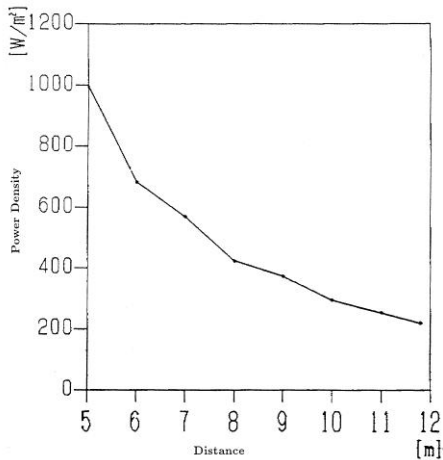

Fig.6 Transmitted power density at different distances from the MILAX phased array



Fig.7 First MPT field experiment with phased array in 1992

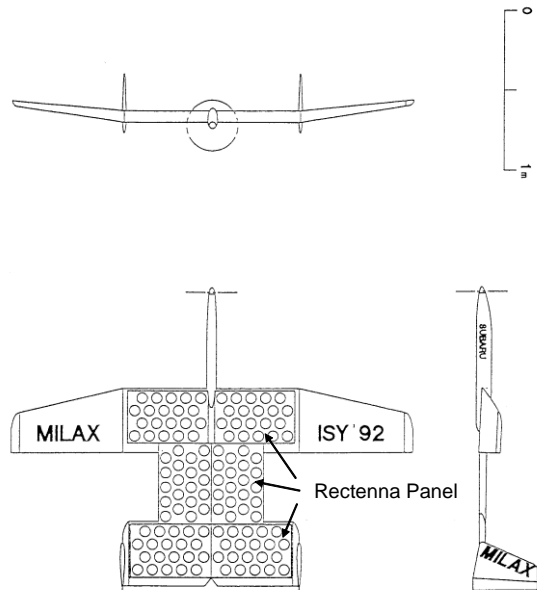

Fig.8 MILAX airplane and rectenna array

After the success of the MILAX, the ISY-METS rocket experiment was conducted in February 1993 [10]. The phased array was arranged to cross plane, and was folded into the head cone of the rocket, as described in Fig. 9. There were ( $2 \times 8 = 16$ ) antennas fitted to each of the four panels. The researchers used the same GaAs semiconductor amplifiers and 4-bit digital phase shifters as those used for the MILAX project. Figure 10 shows the measured beam pattern documented by the researchers that was concentrated at a point 10 m away from the antenna [10]. Owing to the condition of

the data presented, we should consider the vertical axis as the relative power only. The large side lobe was achieved by the positioning of the antennas. Figure 11 shows the concentrated power received by a dipole antenna at different distances from the transmitting array antenna by a solid line, while circles indicate the flight data [11].

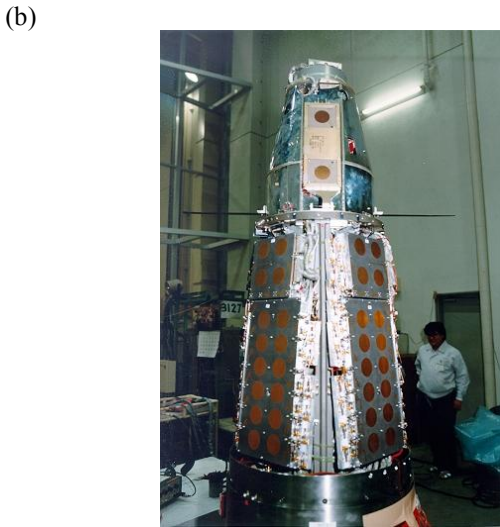

Fig.9 Phased array used in the ISY-METS rocket experiment.  
 (a) Its expanded shape for the experiments, and  
 (b) Its folded shape for launch

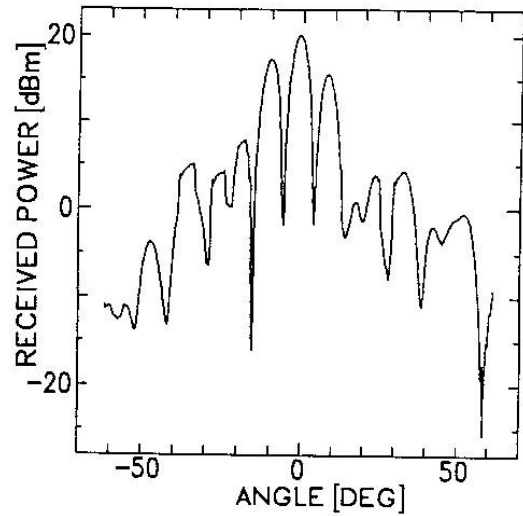

Fig.10 Measured beam pattern of the ISY-METS phased array

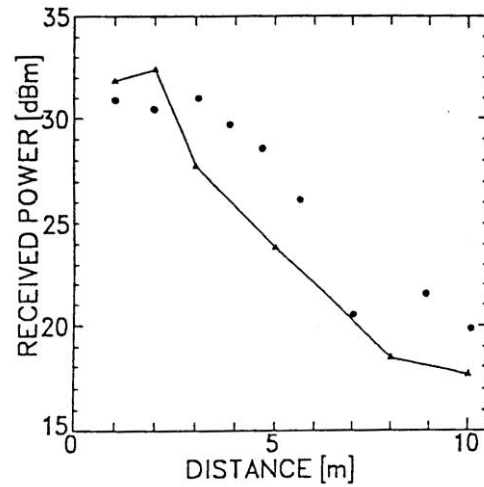

Fig.11 Power received by a dipole antenna at different distances from the ISY-METS array

### III. PHASED ARRAYS IN 2000's

The phased arrays utilized in the MILAX and ISY-METS were insufficient for power transmission. Recently, the phased array technology itself has advanced into synthetic aperture radar. The related technology of adaptive arrays advanced into multiple-input multiple-output (MIMO) systems. However, MPT requires phased array systems with high efficiency.

In Japan, in the 2000s, some trials as part of the development of high-efficiency phased arrays were conducted mainly for SPS applications by the Japanese SPS committee. In FY2000, the SPS committee within JAXA conducted a phased array experiment with solar cells for SPS called the Solar Power Radio Integrated Transmitter (SPRITZ), which was developed mainly by the Mitsubishi Heavy Industries, Ltd. (Fig. 12) [12]. The characteristics of the SPRITZ are as follows:

- 1) Frequency: 5.77-GHz CW, no modulation
- 2) 100 circular microstrip antennas with  $0.75 \lambda$  element spacing

- 3) Right-handed circular polarization
- 4) DC power supply from solar cells (15% efficiency), approximately 166 W
- 5) System: one high power amplifier, a feeder network (power divider of 1 to 100), and a 3-bit phase shifter for each antenna
- 6) Microwave radiation: > 25 W
- 7) Total efficiency: > 15%
- 8) Spurious: < -77.5 dBc
- 9) For demonstration purposes, a LED should be lighted at a distance of 1–2 m.

The total system efficiency of the phased array was 15%, which is without solar cells and includes losses in the feeder network and phase shifter. This efficiency was not sufficient; however, this was an initial trial of a sandwich-type phased array, which was composed of rear solar cells and a front phased array. Theoretical and measured beam patterns are shown in Fig. 13. The beam width was 7.3 degrees. The antenna gain was 17.6 dBi, and the equivalent isotropic radiated power was 58 dBm. A rectenna with 51.2% efficiency received the microwave power and LEDs were activated when the microwave beam was detected.

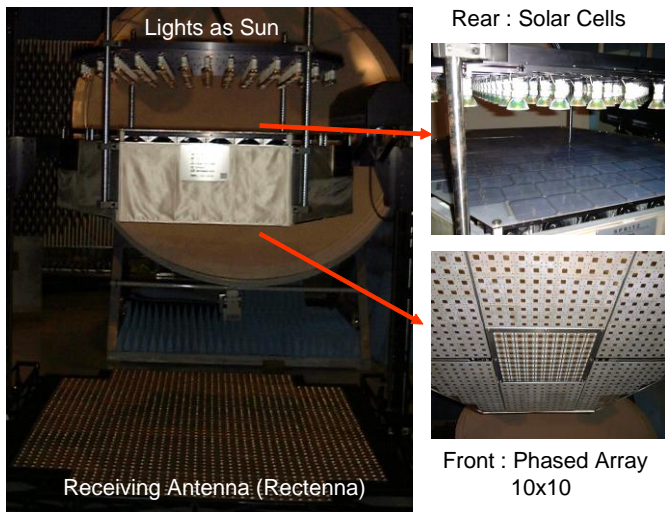

Fig.12 The SPRITZ project conducted in FY2000, demonstrating the phased array developed for the SPS application

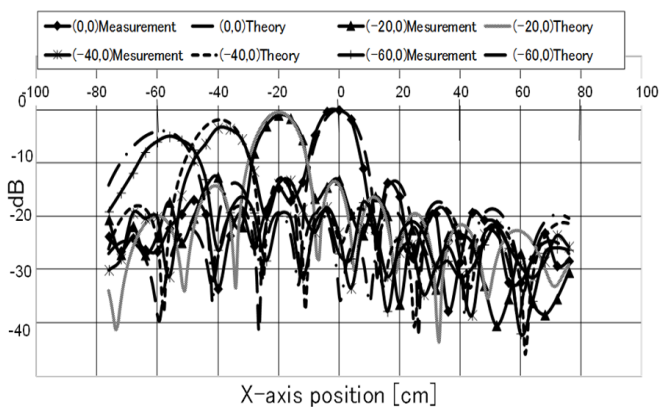

Fig.13 Theoretical and measured beam patterns of the SPRITZ phased array

High efficiency is essential for MPT phased array applications. Innovation aimed at increasing the efficiency or decreasing the loss of high-efficiency microwave circuits was required. In FY2001, Kyoto University and Mitsubishi Electric Corporation developed a parabolic antenna phased array operating at 5.8 GHz in order to attain high-efficiency microwave circuits (Fig. 14). Power loss is evident in the microwave circuitry (except in microwave high-power amplifiers), for example, driver amplifiers, phase shifter and beam control circuits, isolators, or occurrence of grating lobes. Therefore, to decrease power loss, a parabolic antenna phased array incorporating the following innovations was developed [13][14]:

- 1) Direct digital synthesizer (DDS)/PLL oscillators to reduce phase shifter losses.
- 2) A phased array radiator to control the element factor and suppress grating lobe losses.
- 3) A parabolic antenna phased array to concentrate the microwave power (high gain).

One DDS/PLL oscillator generates over 8 W of continuous microwave power. Three DDS/PLLs are used in one parabolic antenna and the phased array is composed of three parabolic antennas; therefore, the total radiated power is above 72 W (8 W × 3 W × 3 W). The diameter and gain of the reflector are 1.2 m and 32.2 dB, respectively. The controllable beam direction is within 5 degrees on the horizontal line. The parabolic antenna spacing is 1.25 m. The theoretical and measured beam patterns at the Fresnel region (7 m away from the baseline) are shown in Fig. 15. The beam direction of the parabolic antenna phased array can be controlled by suppressing grating lobes.

(a)

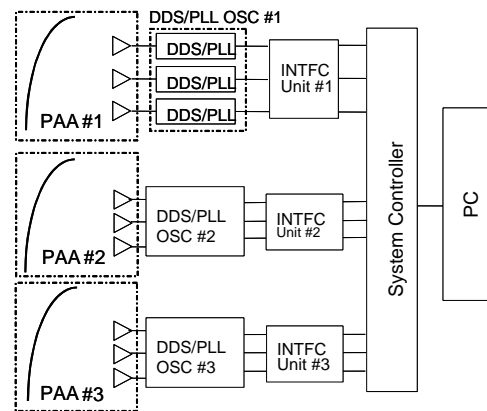

(b)



Fig.14 Parabolic phased array using DDS/PLL oscillators.

(a) System block diagram, and (b) Image of the array

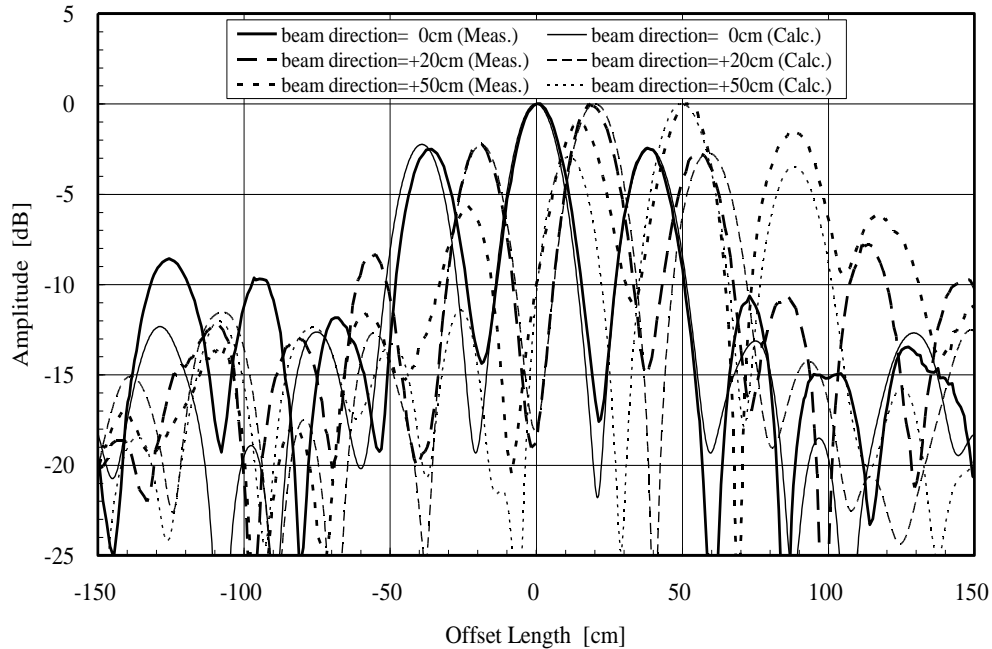

Fig.15 Theoretical and measured beam pattern of the parabolic antenna phased array at the Fresnel region

The USEF SPS Study Team in Japan developed further types of phased arrays for SPS applications. In FY2002, the USEF SPS Study Team and Mitsubishi Heavy Industries, Ltd. developed a phased array with the following characteristics [15]:

- 1) Frequency: 5.77-GHz CW, no modulation
- 2) Nine circular microstrip antennas with  $0.75 \lambda$  element spacing
- 3) High-power amplifier (HPA) with a power and efficiency of  $> 2 \text{ W}$  and  $> 51\%$ , respectively (Fig. 16)
- 4) HPA: class-AB amplifier
- 5) 4-bit digital phase shifters
- 6) Spurious:  $< -50 \text{ dBc}$  at the 2<sup>nd</sup> and 3<sup>rd</sup> harmonics.

The phased array was composed of three layers with receiving, phase-shifting, and transmitting parts as an AIA (Fig. 17). The microwave source was fed from behind the AIA, through the air, and the received microwave was amplified and controlled through the phase-shifting and transmitting parts. The array was approximately  $360 \text{ mm} \times 360 \text{ mm} \times 70 \text{ mm}$  and the antenna gain was 10.8 dBi. The total weight was approximately 11 kg. The radiation efficiency of the transmission antennas was more than 90% with a beam width of approximately 37 degrees (Fig. 18). The measurement result of the beam pattern is shown in Fig. 19, where the microwave beam was controlled in the horizontal direction.

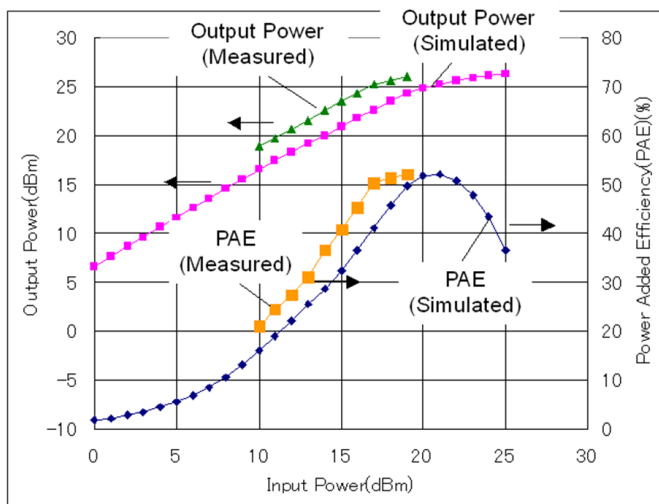
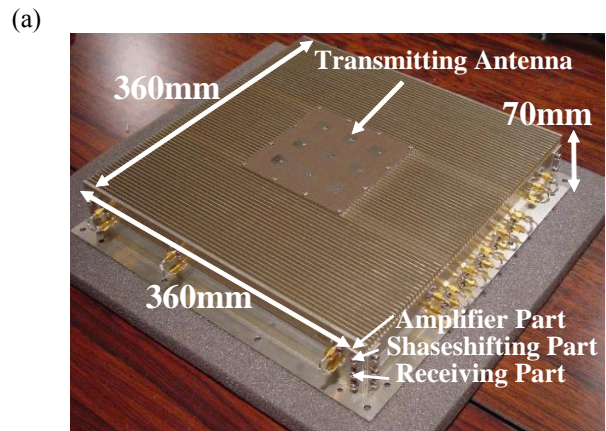

Fig.16 Measured output power, efficiency, and gain of the GaAs amplifiers used in the AIA developed by the USEF SPS Study Team





(b)

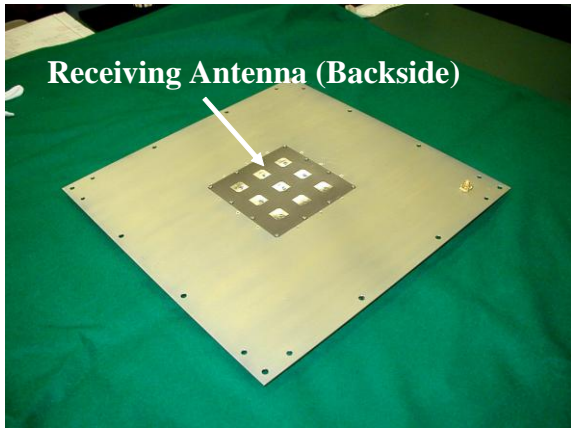

Fig. 17 AIA developed for MPT applications in FY2002

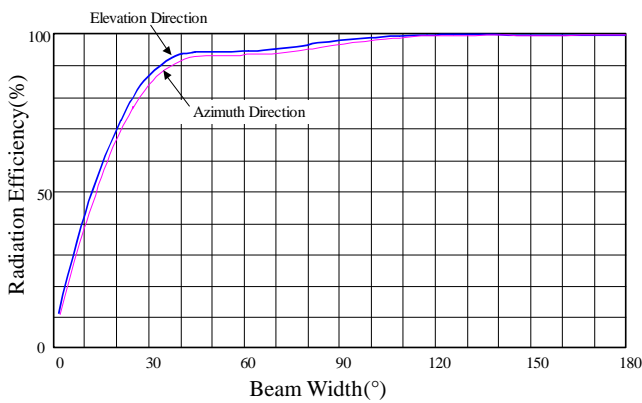

Fig.18 AIA radiation efficiency vs beam width

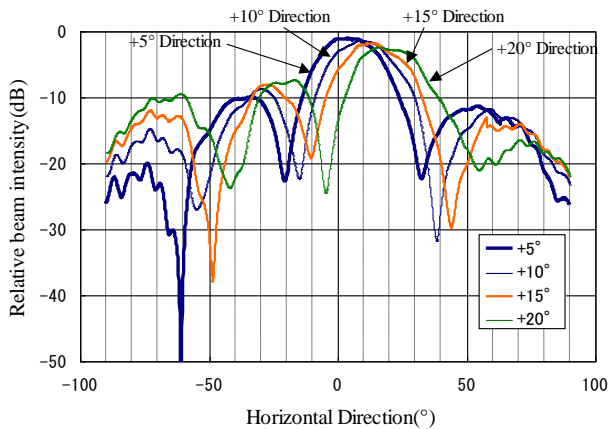

Fig.19 Measured beam pattern of the USEF AIA

The USEF continued to develop a phased array with high efficiency for SPS applications. The Basic Plan for Space Policy was established by the Strategic Headquarters for Space Policy in June 2009. This Basic Plan for Space Policy was based on the Basic Space Law established in May 2008 and was Japan's first basic policy relating to space activities. In this plan, on the basis of nine systems and programs, SPS was

selected for the use and R&D of space resources as follows [16][17]:

"As a program that corresponds to the following major social needs and goals for the next 10 years, a Space Solar Power Program will be targeted for the promotion of the 5-year development and utilization plan." and "government will conduct ample studies, then start technology demonstration projects in orbit utilizing "Kibo" or small sized satellites within the next three years to confirm the influence in the atmosphere and system checks."

On the basis of this plan, a high-efficiency and thin phased array development project, which is supported by METI, started in FY2009 [18]. The author is the Chairperson of this project and Mitsubishi Electric Corporation is developing the phased array. The target of the phased array is as follows:

- 1) Frequency: 5.8-GHz CW, no modulation
- 2) > 70% PAE GaN semiconductor MMIC amplifier (Fig. 20)
- 3) MMIC 5-bit phase shifters
- 4) < 40 mm thickness phased array (Fig. 21)
- 5) 120 cm × 120 cm array
- 6) 76 amplifier/phase shifter modules on each panel of a four-panel system (76 × 4 = 304 modules in the system)
- 7) Four antennas, 1 module sub-array
- 8) Total power > 1.6 kW CW.

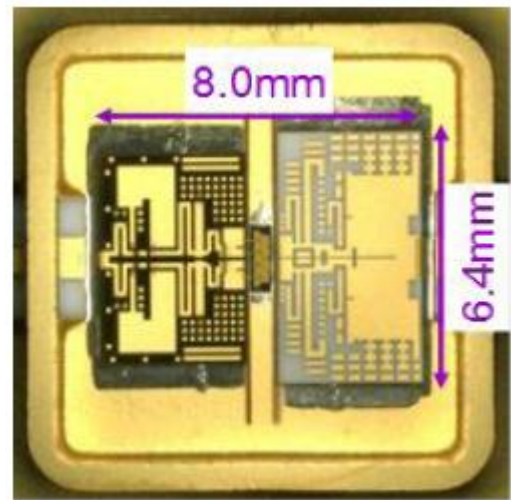

Fig.20 Metal packaged GaN HEMT amplifier [18]

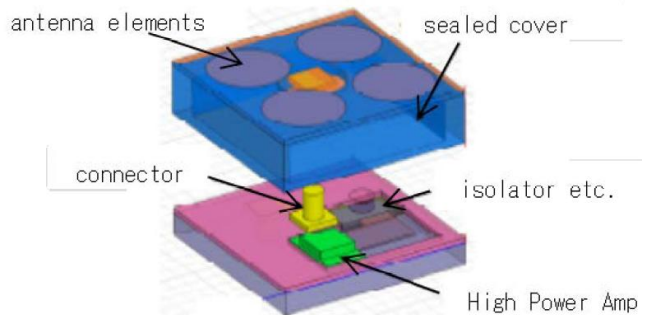

Fig.21 Structure image of the sub-array [18]

In 2008, another field experiment using a phased array was conducted in Hawaii by a team from Kobe University, Japan, and John Mankins from the US. They transmitted

approximately 20 W of microwave power toward a target 150 km away using a phased array. Even though they could not receive enough microwave power, which depended on distance and antenna aperture, the transmission scheme formed the basis for their follow-up work.

At the end of FY2010, a new phased array was installed in Kyoto University as a multipurpose research equipment (Fig. 22) [19][20]. The characteristics of the phased array in Kyoto University are as follows:

- 1) Frequency 5.8-GHz CW, no modulation
- 2) Separated module antenna/active circuits system
- 3) Rigid antenna plane
- 4) 256 elements
- 5) Active phased array with one active circuit for each antenna
- 6) 1.5-kW output microwave power
- 7) Class-F power amplifiers with GaN FETs
- 8) > 7 W output of high-power amplifier as a final stage
- 9) > 70% power added efficiency in the microwave high-power amplifier as the final stage (Fig. 23)
- 10) > 40% as total DC-microwave conversion efficiency
- 11) 5-bit MMIC phase shifters
- 12) < 30 cm thickness as an universal experimental equipment

The phased array system is composed of the phased array equipment, beam control units, and a cooling unit. The beam control units are composed of an antenna control unit, a PC, and the retrodirective equipment. The rectenna array system is composed of the rectenna array, a DC/DC converter, a load, and the retrodirective equipment. Figure 24 shows a simulated beam pattern, and Fig. 25 shows measured beam patterns when the main beam is steered to EL = (-15, -10, -5, 0, 5, 10, and 15) degrees. For each beam steering angle, the obtained steering accuracy was within 0.1 degrees. The phased array is open for inter-university use and international collaborative studies.



Fig.22 New phased array for MPT with GaN FET and F-class amplifier circuits installed in Kyoto University and developed by Mitsubishi Electric Corporation in FY2010

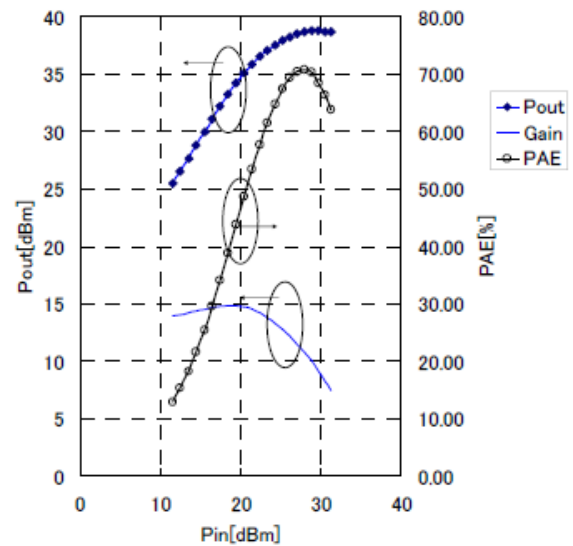

Fig.23 Measured output power, efficiency, and gain of the GaN amplifiers in Kyoto University's phased array

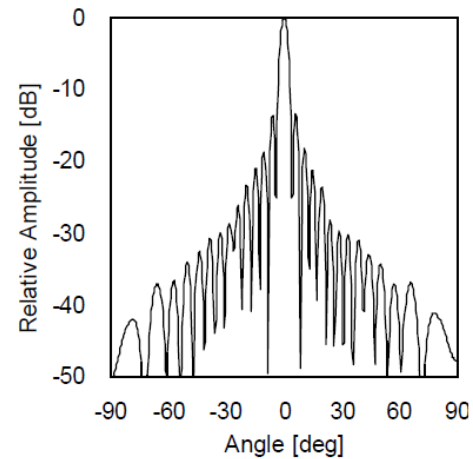

Fig.24 Simulated beam pattern of Kyoto University's phased array

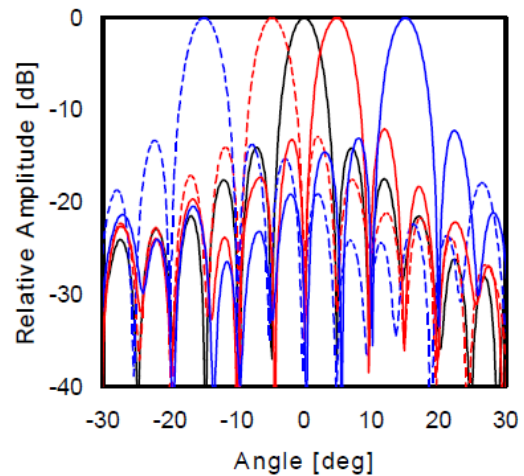

Fig.25 Measured elevation beam pattern of the phased array (beam steering angle: EL = -15, -5, 0, 5, and 15 degrees (AZ = 0 degree))

#### IV. PHASED ARRAYS WITH MAGNETRONS

The compatibility of high-efficiency beamforming of MPT has not been realized with semiconductor technology yet. We at Kyoto University proposed and developed a new phased array using magnetrons. The efficiency of the magnetron is above 70%, and it is the cheapest available microwave device. We cannot control the phase of the magnetron itself because it is a high-power generator. However, we developed a phase controlled magnetron (PCM) with an injection locking technique and a PLL feedback to the magnetron voltage source [21]. The original idea of a PCM came from W. C. Brown [22]. We revised the PCM and developed a phased array using PCMs operating at 2.45 GHz in FY2000 and at 5.8 GHz in FY2001, which are called the Space Power Radio Transmission System for 2.45 GHz (SPORTS-2.45) and the Space Power Radio Transmission System for 5.8 GHz (SPORTS-5.8), respectively [23].

The characteristics of the SPORTS-2.45 array are as follows:

- 1) Frequency: 2.45-GHz CW, no modulation
- 2) 12 (PCMs Output power (matched load) of a single PCM: > 340 W
- 3) PCM efficiency: > 70.5%
- 4) Total (12 PCMs) microwave power: > 4 kW
- 5) 5-bit digital phase shifters on each PCM
- 6) Two-type array antennas (horns and dipoles)
- 7) It includes a retrodirective system with a CW pilot signal of 400 MHz.

For the SPORTS-2.45 array, we always turn off the filament current during power transmission after stable oscillation is achieved because the filament current causes noise in the magnetron. We cannot turn off the filament current in the cooker-type magnetron because a half-wave rectification voltage source is used for the microwave oven. The current heats the filament and heat usually supports electron emission to generate a microwave. Therefore, enough electrons cannot be provided in the cooker-type magnetron with a half-wave rectification voltage source in the absence of filament current. However, when we use a stabilized DC current source with the same cooker-type magnetron, the filament is heated enough without the filament current because the stabilized DC current obstructs filament cooling. We achieved better than  $10^{-8}$  frequency stability, relative to the frequency stability of an input reference signal, using the stabilized DC power source without filament current.

We can select from two types of antenna in SPORTS-2.45 array (Fig. 26). One type is a twelve-horn antenna array with low power loss but with a limited narrow beam scanning capability. The size and gain of each horn antenna are 192 mm  $\times$  142 mm and 17.73 dBi, respectively. System efficiency of the horn array is high, but large side and grating lobes appear when we change the beam direction. The simulated beam pattern in the front direction is shown in Fig. 27. When we change the beam direction to a wide range, grating lobes arise.

The other is a 96 dipole antenna array with power dividers and 1-bit sub-phase shifters. Element spacing is  $0.7 \lambda$ . To expand the beam control area without creating large side and grating lobes, we should shorten the element spacing. But the power of the PCM is too large to connect a small dipole. Therefore, we should divide the power from the PCM to provide for a small dipole. This is the concept of a sub-array. The normal sub-array creates a grating lobe that diffuses the microwave power except for the target when we change the beam direction. Therefore, we proposed a 1-bit sub-phase

shifter that is installed after a power divider to suppress the appearance of a grating lobe. Loss in the digital phase shifter is commonly estimated as 1 dB/1 bit. Therefore, the loss of the 1-bit sub-phase shifter is smaller than that of 4-bit or 5-bit phase shifters. If we do not use any sub-phase shifters, then the loss is the same as a sub-array system, and large side and grating lobes appear. However, we can suppress the grating lobes with the sub-phase shifter system; therefore, we can retain a high-efficiency phased array [23].

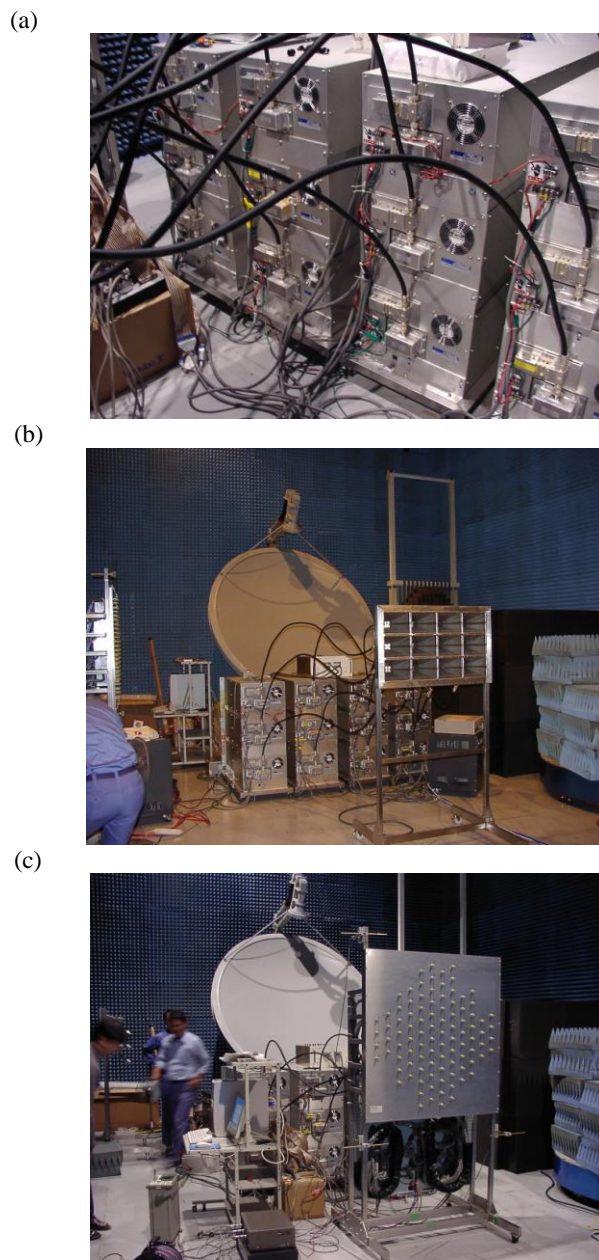

Fig.26 SPORTS-2.45 magnetron phased array.

- (a) 12 PCMs,
- (b) Horn antenna array that is directly connected to the PCMs, and
- (c) Antennas connected to PCMs through 1-bit sub-phase shifters after 8-way power dividers

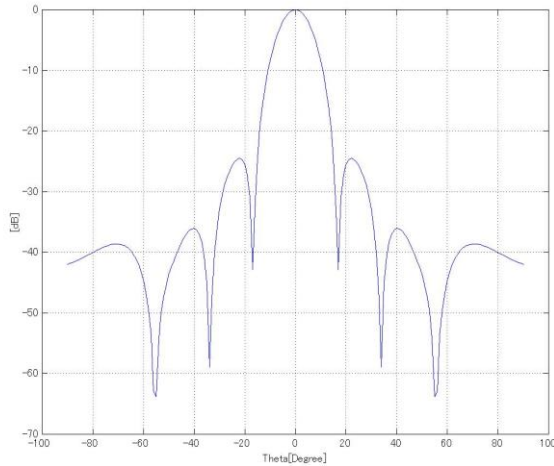

Fig.27 Simulated beam pattern of the 12 horn antenna array

The characteristics of the SPORTS5.8 phase array are as follows:

- 1) Frequency: 5.77-GHz CW, no modulation
- 2) Nine PCMs
- 3) Output power (matched load) of one PCM: > 300 W
- 4) Efficiency of the PCM: > 70%
- 5) Total (nine PCMs) microwave power: > 1.26 kW
- 6) 4-bit digital phase shifters on each PCM
- 7) 288 microstrip antenna in which one PCM is connected to 32 microstrip antenna elements each
- 1) It includes a retrodirective system with a CDMA modulated pilot signal of 4.8 GHz

For the SPORTS-5.8 array, we only adopt a sub-array with power dividers after the 5.8-GHz PCMs without any sub-phase shifters (Fig. 28). The power loss after the PCM is below 1.5 dB. The 5.8-GHz magnetron was developed by Panasonic co. Similarly, we always turn off the filament current during power transmission after stable oscillation is achieved.

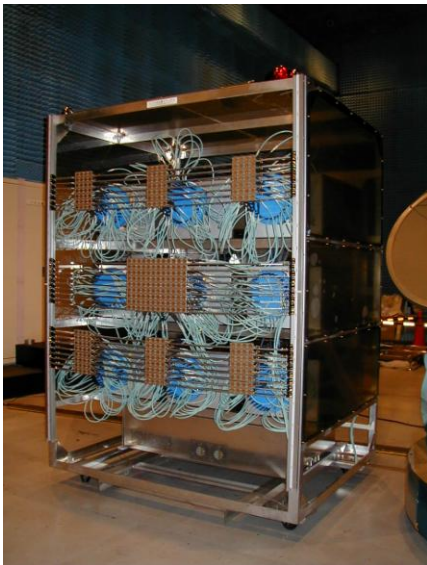

Fig. 28 SPORTS-5.8 magnetron phased array

In 2009, Kyoto University succeeded in a field MPT experiment using PCM technology. We transmitted 2.46-GHz microwave power with two 110-W output power PCMs from an airship to the ground (Fig. 29(a)) [24]. We used two radial slot antennas whose diameter were 72 cm and had a gain and aperture efficiency of 22.7 dBi and 54.6%, respectively. Element spacing was 116 cm (Fig. 29(b)). Theoretical and measured beam patterns are shown in Figs. 30 and 31, respectively. The characteristics of this magnetron phased array are as follows:

- 1) Frequency: 2.46-GHz CW, no modulation, two PCMs,
- 2) Output power (matched load) of one PCM: > 110 W,
- 3) Analog phase shifters on each PCM,
- 4) Two radio slot antennas,
- 5) Weight: < 45 kg (transmitters, antenna, batteries, telemeters, etc.),
- 6) It includes a retrodirective system with a CW pilot signal of 5.8 GHz,
- 7) Data links between the airship and ground with 2.45-GHz Wireless LAN and 429 MHz specified low power radio.

In Kyoto University and Kyushu Institute of Technology we also applied the PCM phased array for MPT to a Mars observation airplane [25]. We consider the magnetron phased array as one of the primary solutions for a high-efficiency phased array system.

(a)

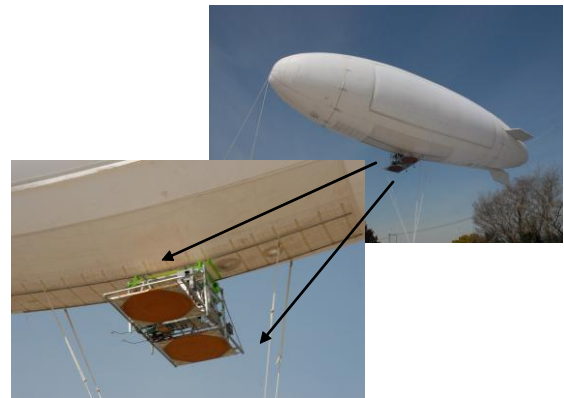

(b)

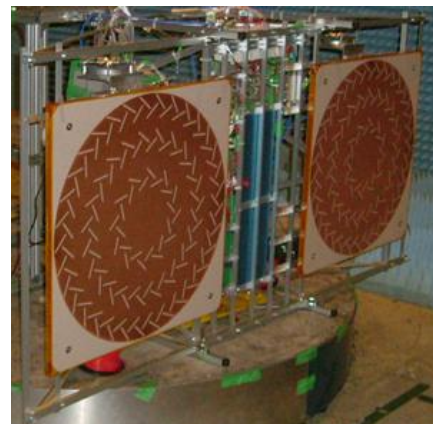

Fig.29 (a) Description of the airship to the ground MPT experiment conducted in 2009, and (b) Radial slot antenna array with two PCMs

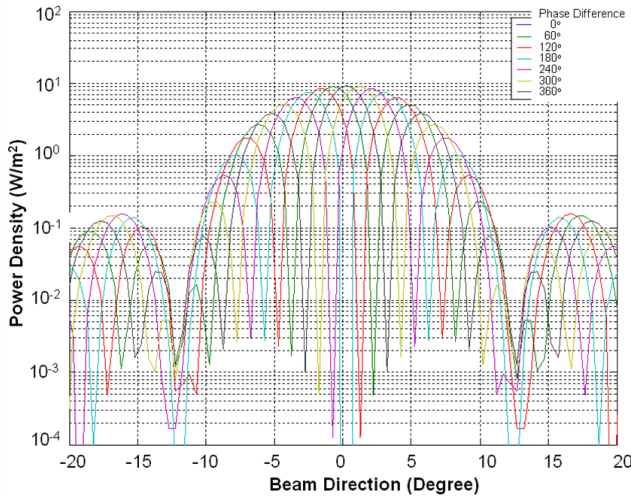

Fig.30 Theoretical beam pattern of the two radial slot antenna array

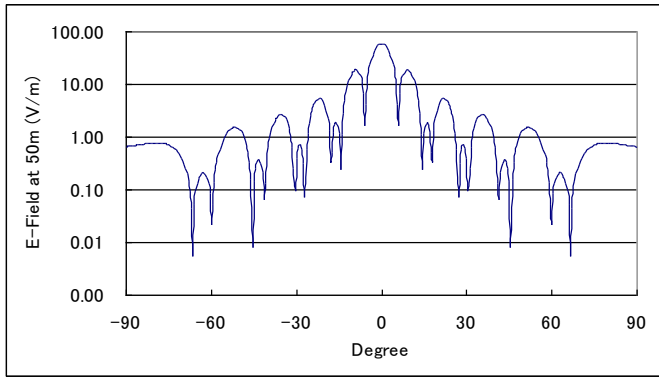

Fig.31 Measured beam pattern (E-field) of the two radial slot antenna array at a distance of 50 m for a radiated microwave power of 600 W

## V. RETRODIRECTIVE SYSTEM IN JAPAN

Target detection is essential for the phased array MPT system to ensure accurate and high-efficiency microwave power transmission. Retrodirective target detection, in which a pilot signal is used for detecting both the target and antenna positioning, is often used for the MPT system. In the world, extensive research is being conducted on retrodirective systems for wireless communications [26]. There are various target detection methods, for example, GPS, optics, and methods of direction of arrival (DOA), such as Multiple Signal Classification. The difference between the retrodirective and other target detecting methods is that only the former can detect both the position of the target and that of the antenna elements (i.e., the shape of the array antenna) in the phased array.

In the conventional retrodirective system, a local oscillator and phase conjugate circuits are installed in the transmitter. Some retrodirective systems use a DOA algorithm with a pilot signal and phase shifters controlled by the DOA result instead of phase conjugate circuits. For the DOA algorithm, the shape

of the array antenna must be assumed. A pilot signal is used in both systems.

In Japan, some types of retrodirective systems were developed after the 1980s. Prior to that, in 1987, Kyoto University and Mitsubishi Electric Corporation developed a retrodirective system with two asymmetric pilot signals (Fig. 32) [27]. Typically, the same frequency for the pilot signal and transmitting microwave is used in the conventional retrodirective systems; therefore, interference between the pilot signal and transmitting microwave may occur. Therefore, researchers proposed two asymmetric pilot signal systems composed of  $\omega_t + \Delta\omega$  and  $\omega_t + 2\Delta\omega$ . Seven antennas were used for receiving two pilot signals as well as microwave power transmission. The microwave frequency was 2.45 GHz.

In 1996, Kyoto University and Nissan Motor Company (presently IHI Aerospace) developed another type of the retrodirective system. In order to suppress interference between the pilot signal and transmitting microwave, they proposed to use a 1/3 frequency pilot signal (817 MHz, Fig. 33) [27]. The transmitting microwave frequency was 2.45 GHz. Eight transmitting antennas were put in a one-dimensional line. On both sides of the transmitting antennas, pilot signal receiving antennas were placed. When we consider only a one-dimensional horizontal line, each pilot signal receiving antenna corresponds to a transmitting antenna. The system did not contain a local oscillator to reduce the unmatched frequency between the pilot signal and local oscillator. Figure 34 illustrates the measured beam pattern of this retrodirective system. When there is no retrodirective target detected, the data indicates the array pattern itself. When the retrodirective system is operating, the microwave beam chases the pilot signal source and data indicates the element pattern.

In FY2003, the USEF SPS Study Team together with Mitsubishi Electric Corporation developed a PLL-heterodyne retrodirective system [28]. The microwave frequency was 5.77 GHz and the pilot signal frequency was 3.884 GHz. There were eight transmitting antennas (the other antennas shown in Fig. 35 are dummies). Beam patterns are shown in Figs. 36(a)–(c).

(a)



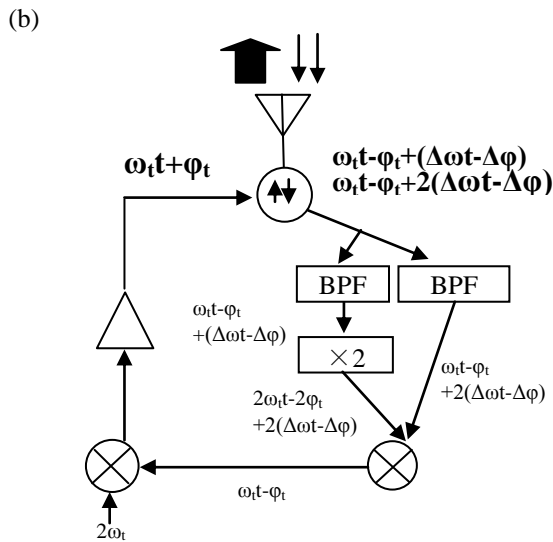

Fig.32 Retrodirective system composed of two asymmetric pilot signals developed by Kyoto University and Mitsubishi Electric Corporation.

- (a) Image of the phased array, and  
 (b) Block diagram of the retrodirective system composed of two asymmetric pilot signals

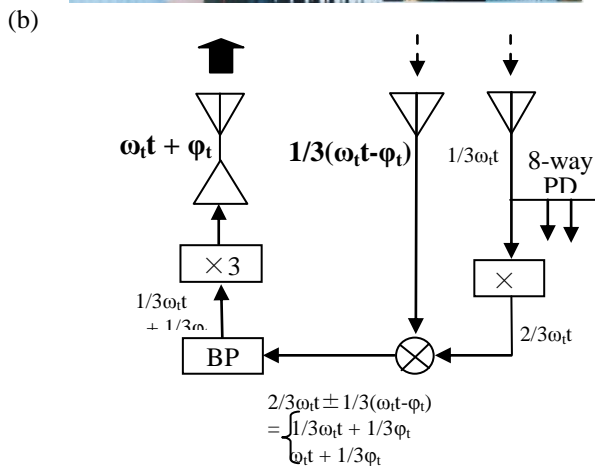
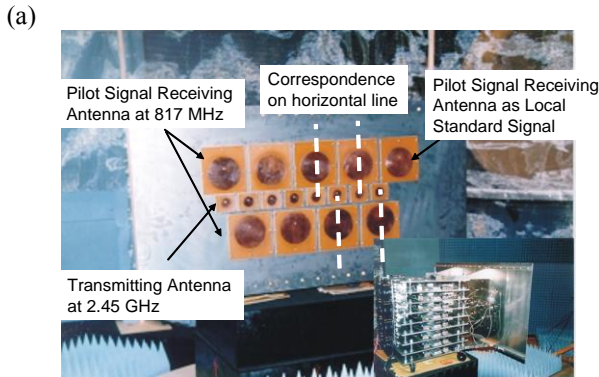

Fig.33 Retrodirective system using the 1/3 frequency pilot signal developed by Kyoto University and Nissan Motor Company.

- (a) Image of the phased array, and  
 (b) Block diagram of the retrodirective system using the 1/3 frequency pilot signal

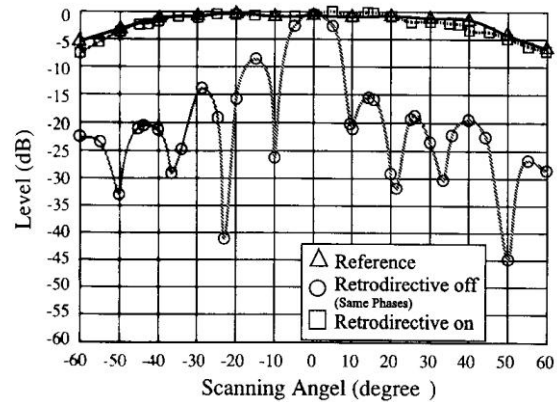
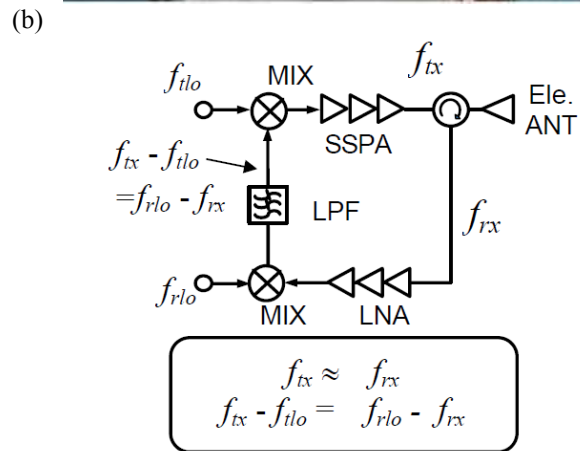

Fig.34 Measured beam pattern owing to retrodirective on and off states



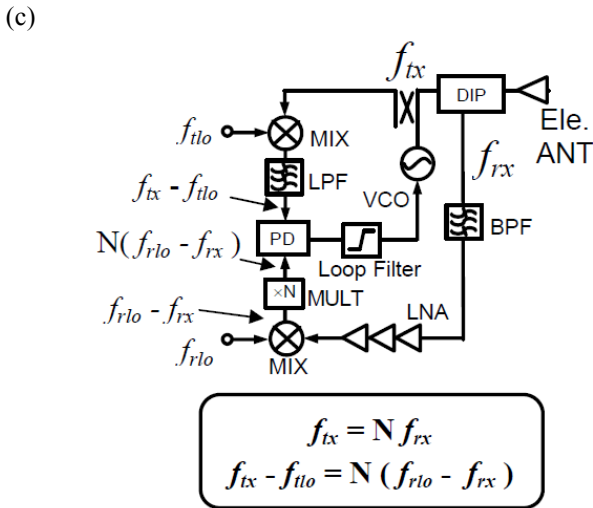

Fig.35 PLL-heterodyne retrodirective system developed by Mitsubishi Electric Corporation and the USEF SPS Study Team in FY2003 [27].  
 (a) Image of the system,  
 (b) Block diagram of the conventional retrodirective system, and  
 (c) Block diagram of the PLL-heterodyne retrodirective system

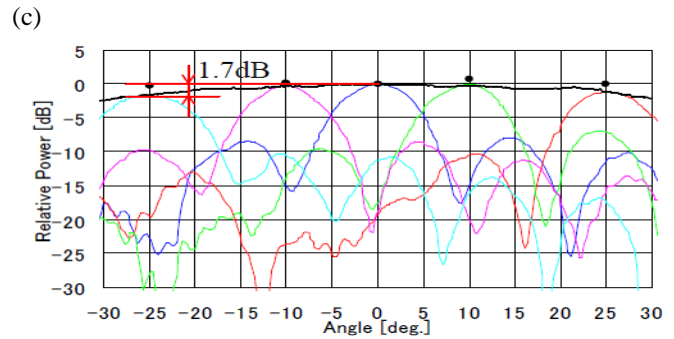
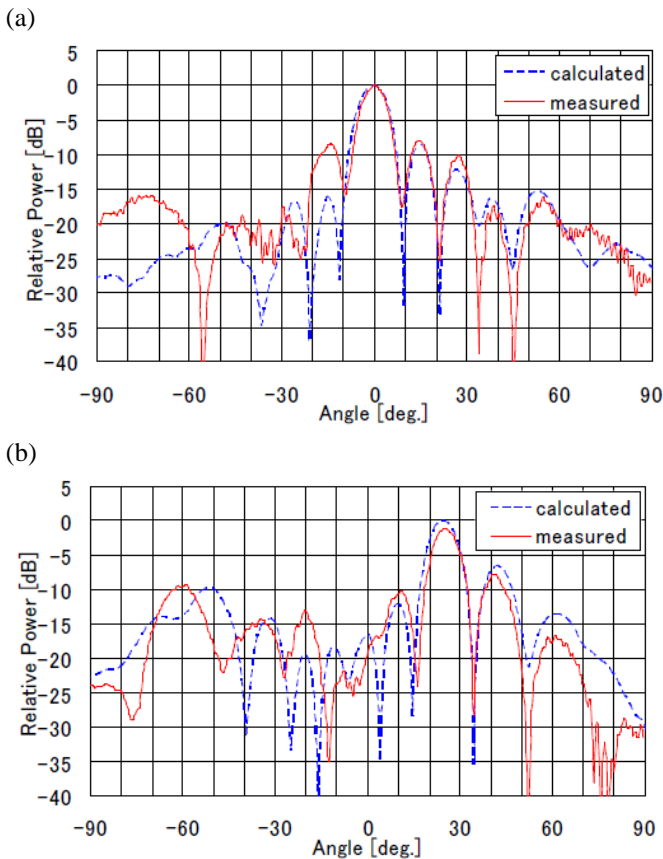

Fig.36 Beam pattern of the PLL-heterodyne retrodirective system [27].  
 (a) Beam target of 0 degree,  
 (b) Beam target of 25 degrees, and  
 (c) Beam pattern with and without the retrodirective system engaged

In January 2006, Kobe University, ISAS, and ESA's research group conducted a successful retrodirective MPT experiment from a rocket to the ground [29][30]. The MPT system structure on the rocket was opened and transmitted microwave power to the pilot signal target.

## VI. CONCLUSIONS

The history of MPT began in the 1960s as efforts aimed at microwave beam concentration in order to increase beam efficiency. To completely develop MPT technology, we require high-efficiency phased arrays and accurate target detection using pilot signals. In Japan, several trials to develop high-efficiency phased arrays and retrodirective target detecting systems have been conducted by Kyoto University, Kobe University, JAXA, ISAS, USEF, NICT, etc. and Mitsubishi Electric Corporation, Mitsubishi Heavy Industries, Ltd., Nissan Motor Company (presently IHI Aerospace), and many other companies. Almost all trials were conducted with regard to SPS applications and in order to satisfy definite experimental targets, for example, to fly a fuel-free airplane. The keywords describing these efforts are "higher efficiency," "higher accuracy of beam control and target detection," and "larger size and light weight" for SPS applications in space and "lower cost" for commercial products. Certainly, some trials were not successful for SPS or commercial applications. By equations (2), the number of antenna elements for SPS applications would need to be larger by six to seven orders of magnitude than those in presently developed projects in order to realize highly efficient MPT at a 36,000 km distance using a 2.45-GHz or 5.8-GHz frequency. In addition, the weight of the phased array would need to be smaller by two to three orders of magnitude in order to reduce the launch costs for the SPS systems. For commercial use, such a large number of the antenna elements and light weight are not required. However, cost is the most important factor for the MPT using the phased array to be widespread. In addition, it is supposed that the cost would need to be lower by three to six orders of magnitude than those of presently available systems. Phased array efficiency is also important because the power is transmitted by the microwaves. But new technologies, such as wide band gap semiconductors, drive the innovation of phased array technologies. With these new technologies, we would like to apply phased array MPT toward becoming a ubiquitous power

source and a means of energy harvesting. We consider that these trials will result in commercially successful and viable MPT applications in the near future.

#### REFERENCES

- [1] Brown, W.C.; "The history of power transmission by radio waves", *IEEE Trans. MTT*, MTT-32, No.9, pp.1230-1242, 1984.
- [2] Dickinson, R. M., "Performance of a high-power, 2.388-GHz receiving array in wireless power transmission over 1.54 km", *1976 MTT-S Int. Microwave Symp. Digest*, pp.139-141, 1976
- [3] DOE and NASA report ; "Satellite Power System ; Concept Development and Evaluation Program", *Reference System Report*, Oct. 1978 (Published Jan. 1979).
- [4] Sasaki, S., K. Tanaka, and Advanced Mission Research Group, "Wireless Power Transmission Technologies for Solar Power Satellite", *Proc. of 2011 IEEE MTT-S International Microwave Workshop Series on Innovative Wireless Power Transmission: Technologies, Systems, and Applications (IMWS-IWPT2011)*, pp.3-6, 2011
- [5] Brookner, E., "Phased Arrays and Radars —Past, Present and Future", *Microwave Journal*, Cover Feature, 2006.1.
- [6] Matsumoto, H. and T. Kimura, "Nonlinear excitation of electron cyclotron waves by a monochromatic strong microwave: computer simulation analysis of the MINIX results", *Space Solar Power Review*, Vol.6, pp.187 –191, 1986
- [7] Kaya, N., H. Matsumoto. S. Miyatake, I. Kimura, M. Nagatomo and T. Obayashi, "Nonlinear Interaction of strong microwave beam with the ionosphere: MINIX rocket experiment", *Space Solar Power Review*, Vol.6, pp.181-186, 1986
- [8] Nagatomo, M., N. Kaya, and H. Matsumoto, "Engineering Aspect of the Microwave- Ionosphere Nonlinear Interaction Experiment (MINIX) with a Sounding Rocket", *Acta Astronautica*, Vol.13, pp.23 – 29, 1986
- [9] Matsumoto, H., N. Kaya, M. Fujita, Y. Fujino, T. Fujiwara, and T. Sato, "MILAX Airplane Experiment and Model Airplane (in Japanese)", *Proc. of the 11th ISAS Space Energy Symposium*, pp.47-52, 1993
- [10] Kaya, N., H. Matsumoto, and R. Akiba, "Rocket Experiment METS Microwave Energy Transmission in Space", *Space Power*, Vol.11, No.1&2, pp.267 – 274, 1993
- [11] Akiba, R., K. Miura, M. Hinada, H. Matsumoto, and N. Kaya, "ISY-METS Rocket Experiment", *The Institute of Space and Astronautical Science report No.652*, 1993.9
- [12] Matsumoto, H., "Research on Solar Power Station and Microwave Power Transmission in Japan : Review and Perspectives", *IEEE Microwave Magazine*, pp.36-45, December 2002.
- [13] Ikematsu, H., T. Mizuno, H. Satoh, K. Takada, I. Mikami, "SPS Concept with High Efficiency Phase Control Technology", *Proc. of Asia-Pacific Microwave Conference 2002*, WS-9-2, 2002
- [14] Mikami, I. T. Mizuno, H. Ikematsu, H. Satoh, N. Shinohara, K. Hashimoto, and H. Matsumoto, "Some Proposals for the SSPS Actualization from Innovative Component Technology Standpoint", *Proc. of 2004 URSI EMT-S*, pp.317 -319, 2004
- [15] Kimura, T., K. Yamamoto, T. Nakada, and USEF SSPS Study Team, "Development of Highly Efficient Active Integrated Antenna", *Proc. of the 4<sup>th</sup> Int. Conf. on Solar Power from Space – SPS'04*, pp.125-130, 2004
- [16] [http://www.kantei.go.jp/jp/singi/utyuu/basic\\_plan.pdf](http://www.kantei.go.jp/jp/singi/utyuu/basic_plan.pdf)
- [17] [http://www.kantei.go.jp/jp/singi/utyuu/keikaku/pamph\\_en.pdf](http://www.kantei.go.jp/jp/singi/utyuu/keikaku/pamph_en.pdf)
- [18] Fuse, Y., T. Saito, S. Mihara, K. Ijichi, K. Namura, Y. Honma, T. Sasaki, Y. Ozawa, E. Fujiwara, and T. Fujiwara, "Outline and Progress of the Japanese Microwave Energy Transmission Program for SSPS", *Proc. of 2011 IEEE MTT-S International Microwave Workshop Series on Innovative Wireless Power Transmission: Technologies, Systems, and Applications (IMWS-IWPT2011)*, pp.47-50, 2011
- [19] Homma, Y., T. Sasaki, K. Namura, F. Sameshima, T. Ishikawa, H. Sumino and N. Shinohara, "New Phased Array and Rectenna Array Systems for Microwave Power Transmission Research", *Proc. of 2011 IEEE MTT-S International Microwave Workshop Series on Innovative Wireless Power Transmission: Technologies, Systems, and Applications (IMWS-IWPT2011)*, pp.59-62, 2011
- [20] Yamanaka, K., Y. Tuyama, H. Ohtsuka, S. Chaki, M. Nakayama, and Y. Hirano, "Internally-matched GaN HEMT High Efficiency Power Amplifier for Space Solar Power Stations", *Proc. of Asia-Pacific Microwave Conference 2010*, pp.119-122, 2010
- [21] Shinohara, N., H. Matsumoto and K. Hashimoto, "Solar Power Station/Satellite (SPS) with Phase Controlled Magnetrons", *IEICE TRANS. ELECTRON.*, Vol. E86-C, No. 8, pp. 1550 - 1555, 2003
- [22] Brown, W. C., 'The SPS transmitter designed around the magnetron directional amplifier', *Space Power*, vol.7, no.1, pp.37-49, 1988
- [23] Shinohara, N., H. Matsumoto, and K. Hashimoto, "Phase-Controlled Magnetron Development for SPORTS : Space Power Radio Transmission System", *The Radio Science Bulletin*, No.310, pp.29-35, 2004
- [24] Mitani, T., H. Yamakawa, N. Shinohara, K. Hashimoto, S. Kawasaki, F. Takahashi, H. Yonekura, T. Hirano, T. Fujiwara, K. Nagano, H. Ueda, and M. Ando, "Demonstration Experiment of Microwave Power and Information Transmission from an Airship", *Proc. of 2<sup>nd</sup> Int. Symp. on Radio System and Space Plasma 2010*, pp.157-160, 2010
- [25] Nagahama, A., T. Mitani, N. Shinohara, N. Tsuji, K. Fukuda, Y. Kanari, and K. Yonemoto, "New Phased Array and Rectenna Array Systems for Microwave Power Transmission Research", *Proc. of 2011 IEEE MTT-S International Microwave Workshop Series on Innovative Wireless Power Transmission: Technologies, Systems, and Applications (IMWS-IWPT2011)*, pp.63-66, 2011
- [26] Miyamoto, R. Y. and T. Itoh, "Retrodirective Arrays for Wireless Communications", *IEEE Microwave Magazine*, pp.71-79, March 2002
- [27] Matsumoto, H., N. Shinohara, and K. Hashimoto, "Activities of Study of Solar Power Satellite/Station (SPS) in RASC of Kyoto University (in Japanese)", *Tech. Report of IEICE*, SPS2002-07 (2002-11) pp.9-14, 2002



- [28] Mizuno T., K. Nishida, H. Okegawa, K. Takada, H. Ikematsu, H. Satoh, and USEF-SSPS Study Team., “Development of a PLL-Heterodyne Hardware Retro directive Antenna (in Japanese)”, 1B06, *Proc of the 48<sup>th</sup> Aerospace Science and Technology Conference*, 2004
- [29] Nakasuka, S., T. Funane, Y. Nakamura, Y. Nojiri, H. Sahara. F. Sasaki, and N. Kaya, “Sounding Rocket Flight Experiment for Demonstrating ”FUROSHIKI SATELLITE” for Large Phased Array Antenna”, *Proc. of International Astronautical Congress (IAC) 2005*, IAC-05-C3.3.01.pdf
- [30] Kaya, N., , M. Iwashita, K. Tanaka1, S. Nakatsuka, and L. Summerer, “Rocket Experiment on Microwave Power Transmission with Furoshiki Deployment”, *Proc. of International Astronautical Congress (IAC) 2006*, IAC-06-C3.3.03.pdf



**Naoki Shinohara** received the B.E. degree in electronic engineering, the M.E. and Ph.D (Eng.) degrees in electrical engineering from Kyoto University, Japan, in 1991, 1993 and 1996, respectively. He was a research associate in the Radio Atmospheric Science Center, Kyoto University from 1998. He was a research associate of the Radio Science Center for Space and Atmosphere, Kyoto University by recognizing the Radio Atmospheric Science Center from 2000, and there he was an associate professor since 2001. he was an associate professor in Research Institute for Sustainable Humansphere, Kyoto University by recognizing the Radio Science Center for Space and Atmosphere since 2004. From 2010, he has been a professor in Research Institute for Sustainable Humansphere, Kyoto University. He has been engaged in research on Solar Power Station/Satellite and Microwave Power Transmission system. He is a member of the IEEE, URSI, the Institute of Electronics, Information and Communication Engineers (IEICE) and the Institute of Electrical Engineers of Japan (IEEJ)