

Title	Current Limiting Performance of Three-Phase Concentric Transformer Type SFCL at Unbalanced Fault Conditions
Author(s)	Shirai, Yasuyuki; Noda, Syo; Yamabe, Kenta; Hattori, Keisuke; Baba, Jumpei; Nishihara, Taichi; Nitta, Tanzo; Kobayashi, Shinichi; Sato, Kenichi
Citation	IEEE Transactions on Applied Superconductivity (2013), 23(3)
Issue Date	2013-06
URL	<a href="http://hdl.handle.net/2433/171245">http://hdl.handle.net/2433/171245</a>
Right	© 2013 IEEE. Personal use of this material is permitted. Permission from IEEE must be obtained for all other uses, in any current or future media, including reprinting/republishing this material for advertising or promotional purposes, creating new collective works, for resale or redistribution to servers or lists, or reuse of any copyrighted component of this work in other works.
Type	Journal Article
Textversion	author

# Current Limiting Performance of Three-phase Concentric Transformer Type SFCL at Unbalanced Fault Conditions

Yasuyuki Shirai, *Member IEEE*, Syo Noda, Kenta Yamabe, Keisuke Hattori, Jumpei Baba, Taichi Nishihara, Tanzo Nitta, *Member IEEE*, Shinichi Kobayashi and Kenichi Sato

**Abstract**— We have proposed a transformer type SFCL whose primary and secondary superconducting coils have rewound structure. The primary coil is connected to a power line. The secondary one is short-circuited and has less turns than the primary coil. For small fault current, only the secondary coil turns to normal state. Inductive component of impedance at the primary terminal mainly appears. For larger fault current, the primary coil also turns to normal state, resistive component additively appears. A three-phase concentric model of the proposed SFCL was designed and fabricated. Each phase SFCL must works independently without large interference among phases. Fundamental current limiting characteristics of the proposed SFCL were reported at a three-line-to-ground fault using a lab scale power transmission system. In this paper, current limiting performance of the SFCL at unbalanced fault conditions was investigated and discussed. Influence of operations of the fault phase SFCL to the non-fault phase ones was discussed. It was confirmed that fault current limiting operation was successfully performed in single-line-to-ground fault, double-line-short fault and double-line-ground fault.

**Index Terms**— superconducting fault current limiter, unbalanced fault, transformer type, inductive limiting, resistive limiting, rewound structure

## I. INTRODUCTION

SINCE electric power systems have been getting more complex, a fault current is getting larger and a capacity of circuit breakers are increasing. Superconducting Fault Current Limiters (SFCLs) are expected to be introduced in order not only to solve the fault current problems but also to improve reliability and stability of the power system. Many studies on SFCL have been carried out [1], [2].

For the application of high temperature superconducting (HTS) wires to a superconducting/normal transition type SFCL, larger resistance of the wire at normal state is preferable. A major problem for the resistive limiting type SFCL is large dissipated power and long recovery time. The

inductive limiting, for example the transformer type SFCL, has more advantages in recovery characteristics than the resistive one. However, in inductive limiting SFCL, when the required inductance is given, the length of the HTS wire and the size of the SFCL may be larger than those of the resistive one.

To solve this problem, a special structure of the transformer type SFCL with rewound coils [3]-[5] has been proposed. A three-phase concentric model of proposed SFCL was designed and fabricated [6]. Basic current limiting characteristics of the proposed SFCL were reported at a three-line-to-ground fault using a lab scale power transmission system [7].

Each phase SFCL must works independently without large interference of the other phase SFCLs especially at unbalanced fault conditions. In this paper, current limiting performance of the SFCL at unbalanced fault conditions was investigated and discussed. Influence of operation of the fault phase SFCL to the non-fault phase ones was discussed with experimental results.

## II. PROPOSED SFCL WITH REWOUND COIL

### A. Concept of Three-phase Coaxial SFCL

The three-phase coaxial SFCL consists of three transformer type SFCLs. The SFCL for each phase has two co-axially wound superconducting coils, that is, a primary coil and a secondary short-circuited coil. The primary coil was wound on two cylinders of different diameter, so that the magnetic field of the inner area of the smaller cylinder became as small as possible, while the flux between cylinders remains (i.e. rewound structure). The primary coil was connected to a power system. The secondary coil was wound in a same way on the same bobbin over the primary coils but with smaller turns and short-circuited. The remained flux between cylinders is cancelled by induced current of the secondary short-circuited coils, therefore a SFCL reactance is small in stand-by mode. The three transformer SFCLs were set with concentric arrangement. Therefore, the three-phase coaxial SFCL has six coils and six cylinders. Here, two inner coils, two middle coils, and two outer coils are called A-phase, B-phase, and C-phase, respectively. The three-phase coaxial SFCL can save its cryostat size, because the A-phase SFCL and the B-phase SFCL were set inside the C-phase SFCL.

It was designed to meet the following three criteria. First,

Manuscript received 9 October 2012.

Y. Shirai, S. Noda and K. Yamabe are with Department of Energy Science & Technology, Kyoto University, Yoshida-Honmachi, Sakyo-ku, Kyoto, 606-8501 Japan (Tel.:+81-75-753-3328 e-mail: shirai@pe.energy.kyoto-u.ac.jp).

K. Hattori and J. Baba are with Dept. of Electrical Engineering, the univ. of Tokyo, Tokyo Japan.

T. Nishihara and T. Nitta are with Meisei Univ, Tokyo Japan.

S. Kobayashi and K. Sato are with Sumitomo Electric Industries, Ltd., Oasaka, Japan..

the impedance of each phase SFCL is same. Second, the trigger current level for limiting of each phase SFCL is same. Third, each phase SFCL must work independently without large interference of the other phase SFCLs.

### B. Design of Three-phase Coaxial SFCL

Specification of BSCCO wire used is indicated in Table I. A cross section of A-phase SFCL and photo of the whole view of the three-phase coaxial SFCL with rewound structure is indicated in Fig. 1. Six cylinders (bobbins) with 500 mm height (400 mm: winding area), and 110, 150 mm diameter for A-phase coil, 190 and 230 mm diameter for B-phase, 270 and 310 mm diameter for C-phase. Lengths of the HTC wires for each phase to get the same reactance are different, while they should be same to get the same resistance at normal state. Therefore, the primary and the secondary coils of A- and B-phase SFCL have non-inductive coils (bifilar wound) in series.

TABLE I  
SPECIFICATION OF BSCCO WIRE USED

Sumitomo DI-BSCCO wire Type ACT (SCT02-2010-017)	
Materials	Silver sheathed BSCCO
Laminate materials	Copper alloy
Width	2.8 mm
Average thickness	0.31 mm
$I_c$ (77K, Self field)	60 A
n-value (77K, Self field)	14
Cross-section ratio (BSCCO : silver : copper alloy)	1 : 3 : 2
Composition ratio of copper alloy (Cu : Sn : others)	99.8 : 0.15 : 0.05

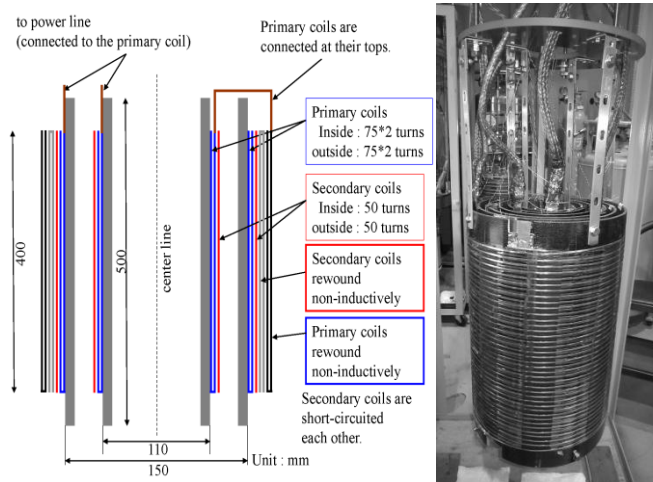

Fig. 1 Cross section of A-phase SFCL and Photo view of model SFCL with rewound structure.

## III. CURRENT LIMITING IMPEDANCE

### A. Current Limiting Impedance of the Proposed SFCL

The current limiting impedance of each phase SFCL was investigated. Fig. 2 shows the equivalent circuit and the

equation of impedance of the SFCL for single phase. The primary coil voltage  $V_1$  and current and  $I_1$  denote the terminal voltage  $V_{fcl}$  and the current  $I_{fcl}$  of SFCL, respectively. While in stand-by mode, since both primary and secondary coils were superconducting mode, the magnetic flux caused by the primary coil is cancelled by the secondary short-circuited coil current  $I_2$ . The impedance of SFCL is only the leakage reactance. For small fault current, only the secondary coil turns to the normal state. Due to the resistance  $R_2$  of the secondary coil, the flux appears and the reactive component due to the primary coil inductance works mainly as the limiting impedance, that is, inductive (L-type) limiting. For larger fault current, both the primary and the secondary coils turn to the normal state, the resistance  $R_1$  of the primary coil is added, that is, the resistive and reactive (R+L-type) limiting.

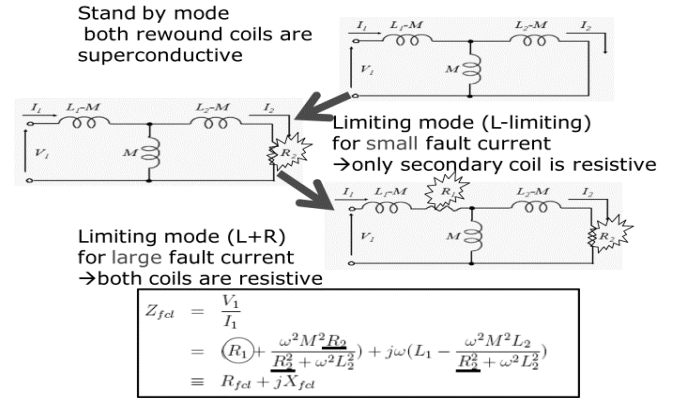

Fig. 2 Equivalent circuit of the proposed SFCL for single phase.

### B. Basic Test of the proposed SFCL

The SFCL was immersed in liquid nitrogen. One of three SFCL was excited by AC power supply (60 Hz, volt slider), while the other ones were not connected to the power supply. Fig. 3 shows one of the experimental result with B-phase SFCL, where the supply voltage  $V_{cir}$ , the terminal voltage of SFCL  $V_{fcl}$ , the current through SFCL (primary coil)  $I_{cir}=I_{fcl}$  and the secondary coil current  $I_2$  from top to bottom during the current limiting operation. Fig. 4 shows the resistance of the primary coil  $R_1$  and that of the secondary coil  $R_2$ . The current of the secondary short-circuited coil ( $I_2$ ) was measured by use of a Rogowski coil.

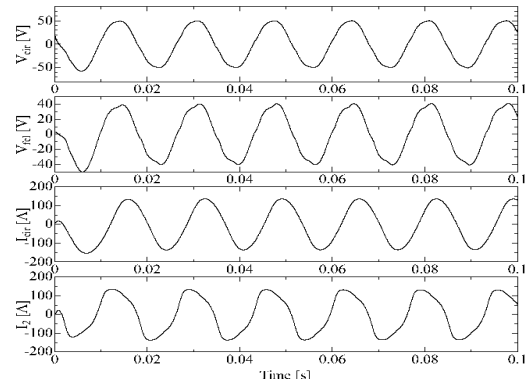

Fig. 3 Basic test result of the current limiting operation with single phase power supply (B-phase SFCL).

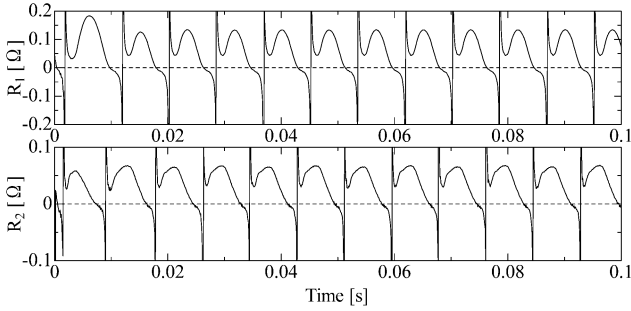

Fig. 4 Resistance of the primary and the secondary coils during the current limiting operation shown in Fig.3.

Fig. 5 shows the measured impedance of B-phase SFCL as a function of the peak value of the current. The impedance of the SFCL increased in two stages. The leakage reactance is about  $0.05 \Omega$ . The current peak exceeds  $38 \text{ A}$ , the secondary coil turns to normal state, the impedance, mainly reactance component, increases as the current increases. As the current peak exceeds about  $80 \text{ A}$ , the primary coil also turns to the normal state, and the resistance component increases.

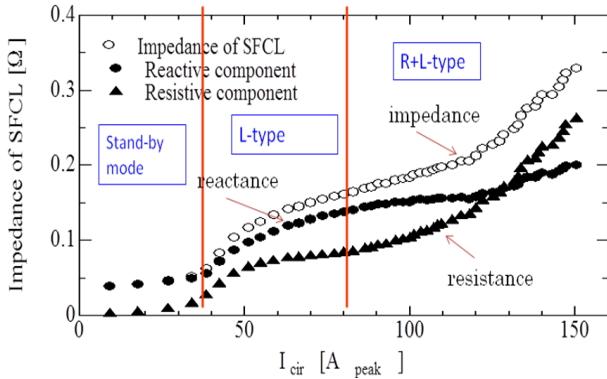

Fig. 5 Impedance of the SFCL as a function of the SFCL current peak value.

### C. Interaction among Each Phase SFCL

Three SFCLs were set in concentric arrangement. During the single phase excitation test, the secondary short-circuited coils of the other un-excited SFCLs are excited by the magnetic flux caused by the excited SFCL. Fig. 6 shows the secondary coil currents of each phase SFCL while B-phase SFCL was excited. During the stand-by mode, as the magnetic flux was small (only the leakage component), the interaction was small. When the current limitation started (break line), the induced current appeared in A- and C-phase SFCL secondary coils and increased as the fault current increased. However, the induced current peak was  $30 \text{ A}$  even when the B-phase primary current (fault current) peak was  $150 \text{ A}$ . The secondary coils of A- and C-phase were still below enough their critical current ( $60 \text{ A}$ ). The A- and C-phase SFCL was kept in stand-by mode. It was confirmed experimentally that the model SFCL can limit each phase fault current individually. The detailed analysis of the proposed SFCL considering mutual inductances among three-phase-concentric SFCL will be performed in another paper.

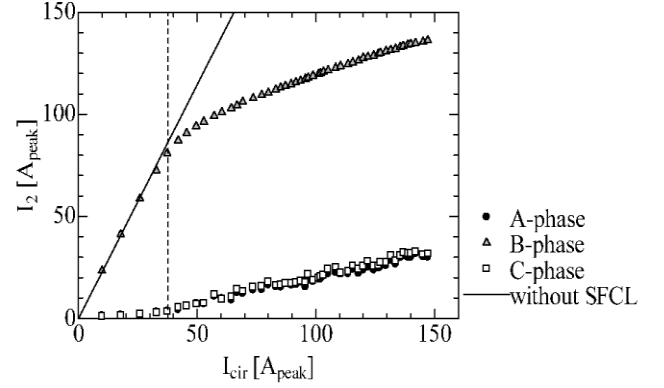

Fig. 6 Secondary coil current of each phase SFCL, while only B-phase SFCL was excited.

## IV. EXPERIMENT AT UNBALANCED FAULTS

### A. Experimental Circuit

Fig. 7 shows the schema of the experimental one-machine infinite bus transmission system of lab-scale. The 3-phase synchronous generator of  $18.26 \text{ kVA}$ ,  $210 \text{ V}$ ,  $50 \text{ Hz}$  was connected to the infinite bus through double transmission lines ( $12.8 \text{ mH}$  air-gap reactors) and the reactor  $L_t$  ( $0.37 \text{ mH}$ ). The switches (Sw1 and Sw2) simulated the Circuit Breakers (CB).

The several unbalanced fault conditions, such as single-line-to-ground (1LG) fault, double-line-short (2LS) fault and double-line-ground (2LG) fault at the generator-side Bus was simulated using Sw3. The model 3-phase SFCL was installed between Sw1 and the fault point. The switch operation sequence is also shown in Fig. 7. At the fault, the Sw3 closed and after  $100 \text{ ms}$ , the fault line was rejected by opening Sw1 and 2. At  $200 \text{ ms}$  after the initiation of the fault, the fault cleared (Sw3 opened). The Sw1 and 2 were re-closed at  $800 \text{ ms}$  to recover the initial operating condition.

In order to confirm the effects of the SFCL, small reactors whose inductances were almost equal to the leakage reactance of SFCLs were installed instead of the SFCLs for “without SFCL” condition.

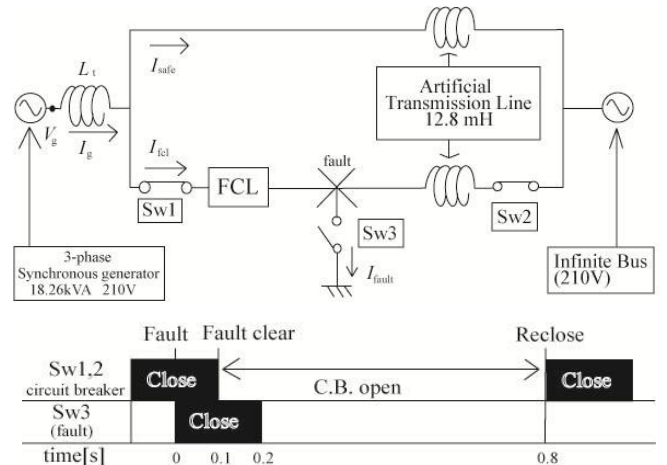

Fig. 7 Schema of the experimental one-machine infinite bus transmission system of lab-scale with SFCL and switch sequence of simulated fault..

**B. Experimental Results and Discussion**

One of the experimental results is shown in Fig.8. The 2LG fault was simulated. The fault was occurred at A and C phase-line. Left figures are with SFCL and right ones are without SFCL. The peak value of the fault line currents  $I_{fcl-A}$  and  $I_{fcl-C}$  exceeded 550 A without SFCL, while they were reduced less than 230 A with SFCL as indicated with break lines.

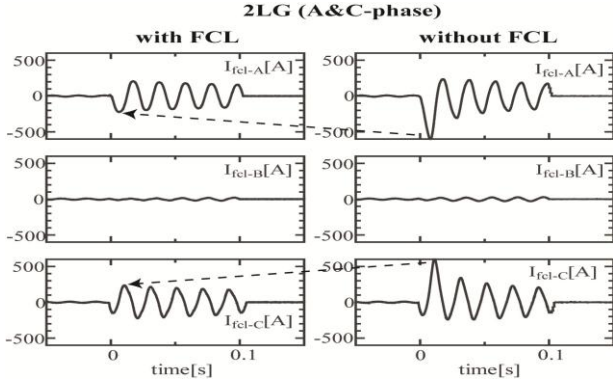

Fig. 8 Fault current at 2LG fault (A and C phase) with and without SFCL.

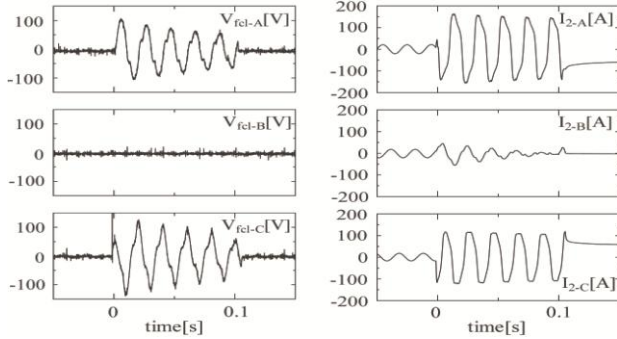

Fig. 9 FCL voltage and secondary coil current at 2LG fault (A and C phase).

Fig. 9 shows the terminal voltages and the secondary coil induced currents of SFCLs. Only the voltages  $V_{fcl-A}$  and  $V_{fcl-C}$  were appeared. The B-phase SFCL was kept in stand-by mode. The secondary coil current of B-phase was kept less than critical current of the wire.

The voltage and the current of A-phase SFCL were shown again together in Fig. 10. The voltage wave forms have two peaks (top peak : middle peak indicated with break lines) within one cycle. It is considered that the lower peak was due to the reactance component of the limiting impedance, while the higher peak was due to the resistance one. The secondary coil resistance is related to the reactance component of the SFCL and the primary coil resistance is related to the resistance component. This result was due to the phase difference between the primary coil resistance and the secondary coil one as shown in Fig. 4. The instantaneous power  $P_A = V_{fcl-A} I_{fcl-A}$  is also shown in Fig. 10. The power  $P_A$  became negative during the inductive limiting period. The dissipated energy, which is given by integral of  $P_A$ , was reduced due to the reactive component of the limiting impedance. It was confirmed that the SFCL was recovered successfully to stand-by mode at the CB reclosure which was 700 ms after the fault line rejection.

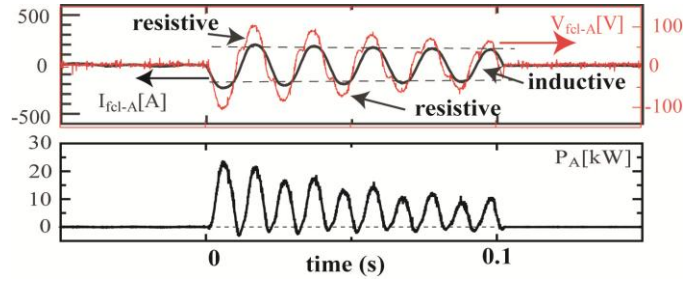

Fig. 10 Phase difference between voltage and current of the A-phase SFCL at 2LG fault and instantaneous power in A-phase SFCL.

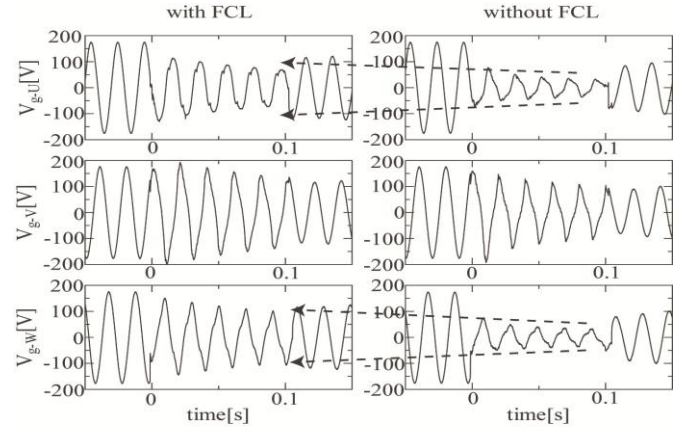

Fig. 11 Generator terminal voltage at 2LG fault (A and C phase) with and without SFCL..

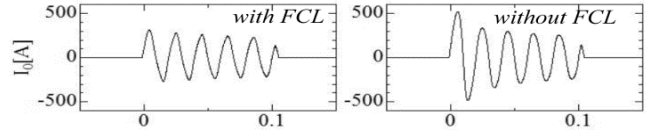

Fig. 12. Zero-phase current  $I_0$  with and without SFCL during the fault.

Seen from the generator terminal voltage  $V_{g-u}$ ,  $V_{g-v}$ ,  $V_{g-w}$ , unbalanced components were observed with and without SFCL (see Fig. 11). The generator voltage was maintained to a certain extent and the generator continued stable operation due to the SFCL current limiting performance.

The ground-fault current  $I_{fault}$  (= zero-phase current  $I_0$ ) was measured as shown in Fig. 12. It was reduced almost half of that without SFCL.

Figs. 13 and 14 show the experimental result of voltage and current of SFCLs at two-line-ground fault with different fault phases, that is, A- and B-phase and B- and C-phase, respectively. There was no considerable difference due to the fault phases.

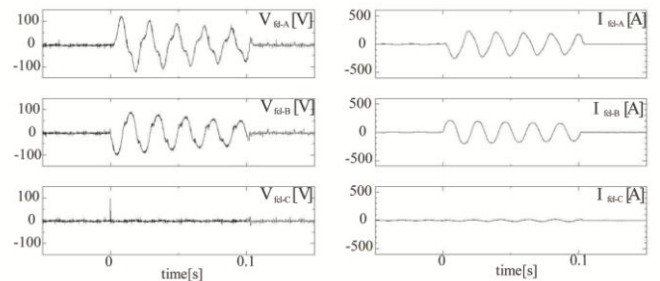

Fig. 13. SFCL voltage and current at 2LG fault (A and B phase).



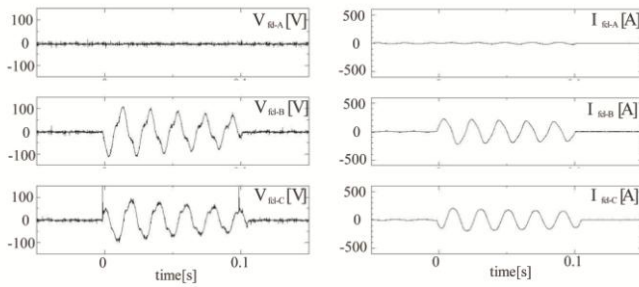

Fig. 14. SFCL voltage and current at 2LG fault (B and C phase).

The current limiting experiments were also carried out at 1LG and 2LS fault with different fault phase combinations.

Fig. 15 shows test result of current limiting performance at 1LG (C-phase) fault. The C-phase fault current peak of 500 A without SFCL reduced to 200 A with SFCL. The secondary coil current  $I_2$  of non-fault phases (A and B) was kept less than the wire critical current. Only the C-phase SFCL terminal voltage was observed.

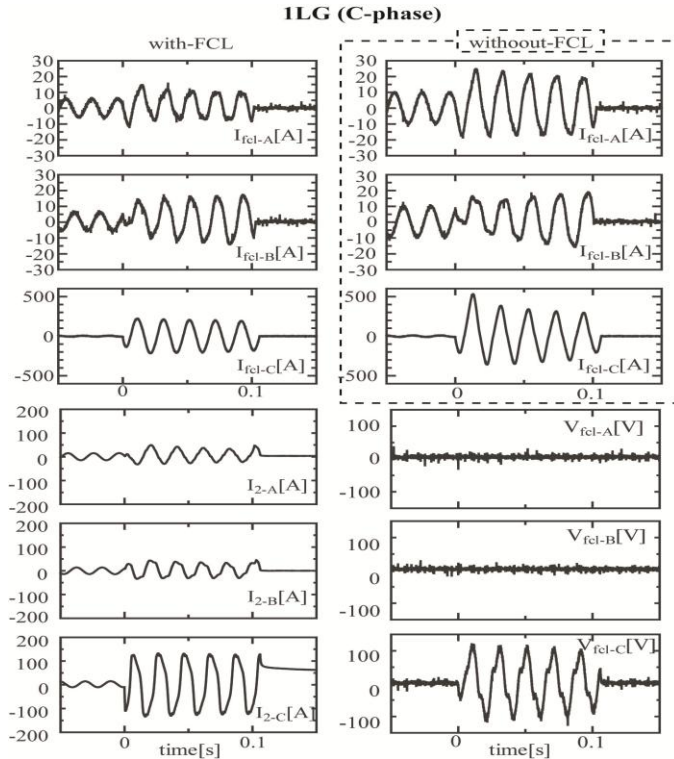

Fig. 15. Voltages and currents of SFCLs at 1LG fault (C phase).

Fig. 16 shows test result of current limiting performance at 2LS (A- and C-phase) fault. The A and C-phase fault current peak of 500 A without SFCL reduced to 200 A with SFCL successfully.

It was confirmed that the current limiting operation of the proposed SFCL was successfully performed even under the unbalanced fault conditions.

## V. CONCLUSION

The new design of a transformer type SFCL, the three-phase coaxial SFCL with rewind structure was proposed.

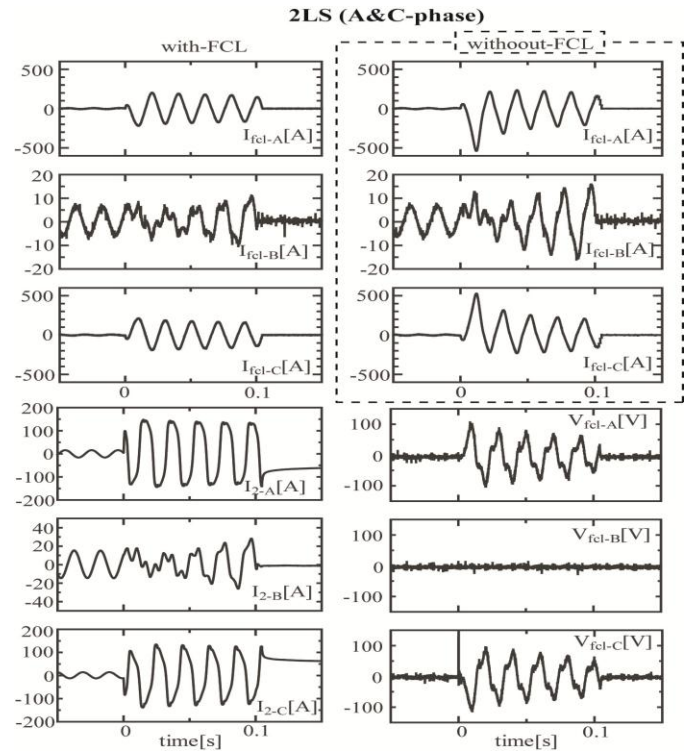

Fig. 16. Voltages and currents of SFCLs at 2LS fault (A and C phase).

Model unit was designed and made for a lab-scale power transmission test facility.

The current limiting performance tests were carried out at the unbalanced fault conditions (1LG, 2LS and 2LG). The fault current peak of around 550 A without SFCL reduced to 220 A at 2LG fault with SFCL, for example. It was confirmed experimentally that the interaction in current limiting operation between the fault phase SFCL and the non-fault phase one at unbalanced fault conditions was not observed.

## REFERENCES

- [1] K. Fushiki, et al., "Design and Basic Test of SFCL of Transformer Type by Use of Ag Sheathed BSCCO Wire," *IEEE Trans. on Applied Superconductivity*, vol. 17, No. 2, pp. 1815–1818, June 2007.
- [2] K. Suzuki, et al., "Conceptual Design of an SFCL by Use of BSCCO Wire," *Journal of physics. Conference series*, Vol. 97, No. 1, p. 012293, 2008.
- [3] T. Nii, et al., "Basic Experiments on Transformer Type SFCL of Rewound Structure Using BSCCO Wire," *IEEE Trans. on Applied Superconductivity*, vol. 19, No. 2, pp. 1892–1895, June 2009.
- [4] Y. Shirai, et al., "Current Limiting Characteristics of Transformer Type HTS Superconducting Fault Current Limiter with Rewound Structure," *Journal of Physics. Conference Series*, Vol. 234, No. 3, p. 032053, 2010.
- [5] S. Oda, et al., "Current Limiting Experiment of Transformer Type Superconducting Fault Current Limiter with Rewound Structure Using BSCCO Wire in Small Model Power System," *IEEE Trans. on Applied Superconductivity*, Vol. 21, No. 3, pp.1307–1310, June 2011.
- [6] S. Oda, et. al. Current Limiting Characteristics of Three-phase Coaxial Transformer Type Superconducting Fault Current Limiter with Rewound Structure, presented at 22nd International Conference on Magnet Technology, Sept. 2011.
- [7] Y. Shirai, et al., Current limiting performance test of 3-phase tri-axial transformer-type SFCL with re-wound structure at 3LG fault in lab-scale transmission system, doi:10.1016/j.physc.2012.03.039, in press, *Physica C: Superconductivity*.