

Title	Pharmacokinetic considerations for targeted drug delivery.
Author(s)	Yamashita, Fumiyoshi; Hashida, Mitsuru
Citation	Advanced drug delivery reviews (2013), 65(1): 139-147
Issue Date	2013-01
URL	http://hdl.handle.net/2433/170274
Right	© 2013 Published by Elsevier B.V.
Type	Journal Article
Textversion	author

Submission To:

Advanced Drug Delivery Review, 25th Anniversary issue

Pharmacokinetic Considerations for Targeted Drug Delivery

Fumiyoshi Yamashita¹ and Mitsuru Hashida^{1,2*}

¹Department of Drug Delivery Research, Graduate School of Pharmaceutical Sciences, Kyoto University, Yoshidashimoadachi-cho, Sakyo-ku, Kyoto 606-8501, Japan.

²Institute for Integrated Cell-Material Sciences, Kyoto University, Yoshidaushinomiya-cho, Sakyo-ku, Kyoto 606-8501, Japan.

*Correspondence author info:

Phone: 81-75-753-4535

Fax: 81-75-753-4575

E-mail: hashidam@pharm.kyoto-u.ac.jp

Abstract

Drug delivery systems involve technology designed to maximize therapeutic efficacy of drugs by controlling their biodistribution profile. In order to optimize a function of the delivery systems, their biodistribution characteristics should be systematically understood. Pharmacokinetic analysis based on the clearance concepts provides quantitative information of the biodistribution, which can be related to physicochemical properties of the delivery system. Various delivery systems including macromolecular drug conjugates, chemically or genetically modified proteins, and particulate drug carriers have been designed and developed so far. In this article, we review physiological and pharmacokinetic implications of the delivery systems.

Keywords: drug delivery system, targeted drug delivery, pharmacokinetics, tissue uptake clearance, macromolecular prodrugs, chemical modified proteins, nanoparticles, liposomes

Contents

1. Introduction
2. Clearance analysis for tissue distribution of drug carriers
 - 3.1. Reduction of glomerular filtration
 - 3.1.1. Physicochemical properties determining glomerular filtration
 - 3.1.2. Prolonged blood retention of therapeutic proteins by chemically or genetically modification
 - 3.2. Reduction of reticuloendothelial uptake
 - 3.2.1. Complement activation by drug carriers
 - 3.2.2. Physicochemical properties determining phagocytosis of particulate drug carriers
 - 3.2.3. Prolonged blood retention of particulate drug carriers
4. Enhanced permeability retention (EPR) effect for tumor drug targeting
5. Control of drug release from polymer conjugates
6. Acceleration of delivery of drugs to organs and tissues
 - 6.1. Enhanced delivery by cationization
 - 6.2. Receptor-mediated delivery of therapeutic proteins
 - 6.3. Receptor-mediated delivery of particulate carriers
 - 6.4. Pharmacokinetic considerations of receptor-mediated drug delivery
7. Conclusions and future directions

1. Introduction

In vivo fate of a drug following administration is determined by its physicochemical (e.g., passive diffusion) and biochemical (e.g., interactions with metabolizing enzymes and transporters) properties, in addition to biophysical properties of the body. Since drugs are not usually endogenous substances that play important roles in maintaining homeostasis of the body, they are not provided by the biological system with an appropriate biodistribution profile. In other words, pharmacokinetics of a drug is not necessarily optimized to exhibit its pharmacological actions. Lack of selectivity in biodistribution sometimes leads to unwanted side effects, particularly for anti-cancer drugs that have severe cytotoxicity. In order to ensure safety and efficacy, drugs are required to be delivered to their target site selectively at an optimal rate.

Drug delivery system involves technology designed to maximize therapeutic efficacy of drugs by controlling their biodistribution profile. To offer such a function, the delivery system itself is required to have an optimal selectivity and specificity towards the target tissues or cells. A number of techniques intended for targeted drug delivery have been proposed and developed so far, being classified roughly into macromolecular and particulate drug carriers. The biodistribution profiles of carrier systems are determined by their physicochemical and biochemical properties, similarly to the case of drugs. To clarify qualitative and quantitative relationships of these properties with pharmacokinetics is important in developing new carrier systems suitable for targeted drug delivery. Physiologically-based pharmacokinetics (PBPK) modeling that was proposed first by Bischoff and Dedrick [1; 2] in the late 60's is a powerful tool for understanding the pharmacokinetic profile of drugs mechanistically. In addition, the introduction of clearance concepts, where clearance in drug elimination organ is derived from the blood flow and the intrinsic ability of the organ to eliminate a drug, clarified the physiological interpretation of drug elimination [3]. The PBPK modeling approach is also available for evaluating pharmacokinetic profiles of drug delivery system [4; 5].

By linking pharmacokinetic evaluations with physicochemical properties of the systems, various factors influencing their biodistribution have been clarified so far. This article aims to review physiological and pharmacokinetic implications of various drug delivery systems, especially paying attention to the physicochem/pharmacokinetics relationship.

2. Clearance analysis for tissue distribution of drug carriers

Since mass transfer is a probabilistic event, it is proportional to the concentration (or mass) of the substance. Taken together with that, the mass balance in tissue involving uptake and elimination can be represented as,

$$\frac{dX_i}{dt} = CL_{app,i} \cdot C_p - k_{elim} \cdot X_i \quad (1)$$

where X_i and C_p represent the amount of a substance in tissue and its concentration in plasma, respectively; and $CL_{app,i}$ and k_{elim} represent apparent tissue uptake clearance and elimination rate constant, respectively. At an initial time phase, the efflux process is negligible, so that Eq. 1 can be approximated to:

$$\frac{dX_i}{dt} = CL_{app,i} \cdot C_p \quad (2)$$

In other words, by analyzing the data at earlier time points, tissue uptake characteristics of the substance can be estimated.

An appropriate selection of tracer agents can ensure the approximation. Generally, macromolecular and particulate carriers are likely to undergo degradation following cellular uptake. When traced with radioisotopes, the presence of radioactive degradation fragments may interfere with the evaluation of distribution kinetics of an intact carrier system. Therefore, radiolabeling with ^{111}In is preferred for biodistribution studies for protein drugs and plasmid DNA, because the metabolite ^{111}In -chelate complex is trapped in the cells due to its plasma membrane-impermeability [6].

Integration of Eq. 2 gives:

$$CL_{app,i} = X_i(t) / \int_0^t C_p dt = X_i(t) / AUC_{p,0-t} \quad (3)$$

where $AUC_{p,0-t}$ represents the area under the plasma concentration-time curve. Plasma concentration-time profile can be expressed as a function of one or more exponentials in many cases. Then, the $AUC_{p,0-t}$ values at any time point can be calculated by fitting an equation to the experimental data using a least-squares method. According to Eq. 3, $CL_{app,i}$ can be estimated from the slope of regression for $AUC_{p,0-t}$ vs $X_i(t)$ relationship.

(Figure 1)

The clearance concept allows us to assess an absolute efficiency of mass transfer. Since tissue uptake or urinary excretion processes are in parallel, the amount in tissue or eliminated depends on a balance of the entire processes. Therefore, the amount in tissue or eliminated cannot simply be referred to as the measure of mass transfer. The rate of transport can be normalized as clearance, under the assumption that mass transfer occurs from the blood or plasma. Therefore, clearance depicts mutually independent tissue uptake rate. To compare disposition characteristics of drug delivery systems directly and systematically, application of the clearance concept is necessary. Figure 1 shows a scatter plot of hepatic uptake versus urinary excretion clearances for various macromolecules and proteins. As it will be discussed later, the clearance analysis helps us to understand relationship between pharmacokinetic properties and physicochemical or biochemical properties.

3. Prolongation of retention time in blood

Prolonged retention time in blood provides drugs with a chance to distribute to their target tissue/organ, leading to an increase in duration of their pharmacological activities. Glomerular filtration and hepatic uptake of drug carriers should be avoided, as long as neither kidney nor liver is a drug target.

3.1. Reduction of glomerular filtration

3.1.1. Physicochemical properties determining glomerular filtration

There are numerous pores, called as fenestrae, in the glomerular endothelium. Since the diameter of the fenestrae is as large as 70-90 nm [7; 8], macromolecules freely pass through the endothelium. Therefore, the rate of glomerular filtration is rather limited by transport across basement membranes which support glomerular endothelial cells. According to electron tomography studies, the glomerular slit-pores are 35 Å (3.5 nm) in diameter [9]. It is limited for molecules of the size of albumin (about 80×80×30 Å) to pass through these pores [9]. However, it has been reported that quantum dots with a final hydrodynamic diameter of smaller than 5.5 nm (e.g., 4.99 and 4.36 nm) are rapidly excreted into urine [10]. It is in good

agreement with a general finding that macromolecules with a molecular weight of <50,000 (approximately 6 nm in diameter) are susceptible to glomerular filtration [4]. In fact, dextran with the molecular weight of 70kDa has a 50-times less urinary excretion clearance than that of 10kDa dextran (Figure 1). Charge of macromolecules is another determinant of glomerular filtration. Since the basement membrane of glomerulus is mainly comprised of glycosaminoglycans, negatively charged polysaccharides, it also exhibits permselectivity towards charged macromolecules [7; 8]. Positively charged macromolecules are filtered more effectively than anionic macromolecules. cationization with diethylaminoethyl group (DEADex) increases the urinary excretion of 70kDa dextran, whilst anionization with carboxymethyl group (CMDex) decreases it (Figure 1). Urinary clearance of bovine serum albumin (67kDa) is much lower than 70kDa dextran and CMDex, in spite of a similar molecular size. It is attributed to involvement of specialized endocytic reabsorption mechanisms [11; 12].

3.1.2. Prolonged blood retention of therapeutic proteins by chemically or genetically modification

Clinical application of protein drugs is often limited by their short biological half-lives [13]. Various factors are involved in rapid elimination of proteins, including proteolytic degradation, reticuloendothelial uptake, and receptor-mediated clearance. Glomerular filtration is a major problem for many therapeutic proteins. Conjugation with biocompatible polymers is a simple and effective way to reduce glomerular filtration of protein drugs and subsequently prolong their blood circulation time. Polyethylene glycol is the most popular macromolecular modifier for this purposes, as represented by pegylated interferon α (PEG-IFN α) [14] and granulocyte colony-stimulating factor (PEG-GCSF) [15]. In addition, pegylation of proteins can reduce their hepatic uptake. Catalase (235 kDa), one of anti-oxidant enzymes, is known to be rapidly taken up by the liver, mainly by the hepatocytes [16]. Pegylation of catalase reduced total body clearance by 67 times (34,900 and 520 μ L/h for native catalase and PEG-catalase, respectively) [16]. The total body clearance of PEG-catalase is on the same order of that of BSA (131 μ L/h) and dextran (685 μ L/h). Prolonged retention of catalase in plasma resulted in augmented inhibitory effects on tumor metastasis [17; 18; 19] and diabetes [20]. However, it expectedly hampered a protective effect of catalase on reactive oxygen

species (ROS)-mediated liver injury, due to reduction of hepatic uptake [16]. As it will be described later, catalase must be delivered to liver non-parenchymal cells to weaken ROS-mediated liver injury.

Introduction of lipophilic moieties to the proteins prolongs their plasma half-life due to binding to plasma proteins or blood cells. A typical example is SMANCS, which is poly(styrene-co-maleic acid/half-n-butyl ester) (SMA) conjugated with neocarzinostatin (NCS) [21; 22]. In spite of the molecular size being 16 kDa, SMANCS is bound to albumin and apparently exhibits a molecular size of ~80 kDa which is large enough to escape from glomerular filtration. Lecithinized SOD is another example of prolongation of the plasma half-life [23; 24; 25]. It possesses a high affinity to plasma membrane components and promiscuously binds to blood and endothelial cells [23]. Another method to prolong the plasma half-life and pharmacological activity is to genetically fuse therapeutic peptide/protein drugs with albumin. Successful examples include glucagon-like peptide 1 [26], interferon alfa-2b [27], thioredoxin [28], and single chain diabodies [29]. Fusion protein technologies have also been used for active targeting, which includes RGD peptide-fused endostatin [30] and tumor necrosis factor-related apoptosis-inducing ligand (TRAIL) [31] for targeted delivery to the tumor neovasculature.

3.2. Reduction of reticuloendothelial uptake

The reticuloendothelial system (RES) is a part of the immune system, comprised of phagocytic cells in different organs of the body. Phagocytic cells are capable of engulfing microorganisms and foreign substances that may cause harm to the body. Particulate drug carriers are required to escape from reticuloendothelial uptake for long-term retention in the systemic circulation.

3.2.1. Complement activation by drug carriers

Phagocytosis of particulate drug carriers is accelerated by association with complements and immunoglobulins [32; 33]. There are three pathways of complement activation: i.e., classical pathway, alternative pathway, and lectin pathway. The classical pathway starts binding of C1q to antigen-bound IgG or IgM, followed by C1 complex formation and activation of C2-C9 components. Even in the absence of immunoglobulins, C1q can bind via its collagen-like stalks to a variety of

substances including proteins, polyanions, DNA, and anionic liposomes. The alternative pathway started with C3 components without involving the binding C1, which is mainly activated by complex polysaccharides and lipopolysaccharides. In the lectin pathway, the complement is activated by a serum protein, called mannan (mannose)-binding protein (MBP) or mannan (mannose)-binding lectin (MBL), which is able to bind particular carbohydrates, such as D-mannose, L-fucose, and N-acetylglucosamine, on the surface of microorganisms. MBP is known to bind to and accelerate phagocytosis of mannosylated liposomes [34; 35].

On the other hand, serum albumin might partially protect nanoparticles from being opsonized, based on the finding that pre-incubation of polystyrene nanoparticles with serum albumin reduces their clearance from blood [36]. It has also been known that particulate carrier systems such as liposomes [37; 38] and polystyrene microspheres [39; 40] are associated with serum albumin in a nonspecific manner. However, it should be noted that, unless polystyrene nanoparticles were pre-incubated with serum albumin, the total body clearance of the particles was 4-5 times higher [36]. The total body clearance of polystyrene nanoparticles is as high as to correspond to the single-pass hepatic extraction of approximately 40 %. Thus, the protective effect of serum albumin would be limited under in vivo condition, even though a high concentration (~4 g/dL) of serum albumin is present in serum.

3.2.2. Physicochemical properties determining phagocytosis of particulate drug carriers

Particulate drug carriers are nano-sized assemblies that are stably dispersed by the help of amphipathic ingredients. They are primarily divided into lipid/surfactant-based (liposomes and emulsions) and polymer-based (polymeric nanospheres and micelles). Formulation characteristics such as structural integrity, sustainability, drug-holding capacity depends largely on the structural characteristics of the particulate carriers. However, overall pharmacokinetic behavior appears to be rather influenced by macroscopic characteristics of the particulate carriers such as the size and surface properties.

Particle size is a key parameter affecting phagocytic uptake of particulate carriers. For various polymer particles, higher phagocytic uptake has been observed when their size increases from around 200 nm to several microns [41]. This might

be related to opsonization of the particles. Adsorption of opsonins is known to be lower for smaller particles [39; 42; 43], presumably due to geometrical problems in efficient arrangement of complements on their highly curved surface structure [44].

Surface properties such as charge and hydrophobicity are critical in determining interactions of particulate carriers with biological components. It has been known for a long time that negatively charged liposomes containing certain anionic lipids such as phosphatidylserine, phosphatidylglycerol, and phosphatidic acid are rapidly taken up by macrophages [38; 45; 46]. Although involvement of scavenger receptors is controversial [47; 48], activation of the complement system is responsible for hepatic clearance of anionic liposomes [38; 49]. Hydrophobicity also plays an important role in biodistribution of particulate carriers. Serum proteins including IgG and other opsonins have high affinities to the hydrophobic surface of particles [50]. Coating with lecithins has been shown to significantly reduce hepatic uptake clearance of polystyrene nanospheres, as well as uptake by isolated Kupffer cells [51].

3.2.3. Prolonged blood retention of particulate drug carriers

It has been well-known for many years that particulate drug carriers are rapidly taken up by the RES, including liposomes [45; 52] and microspheres [53; 54]. For example, hepatic uptake clearance of polystyrene microspheres with a particle size of 500 nm have been estimated to be 7.6 mL/min in rats [39], which indicates that approximately a half of microspheres flowing into the liver is taken up by the liver. However, grafting hydrophilic polymers onto particulate carriers can sterically hinder interaction of the particle cores with opsonins and cell membranes. Among hydrophilic polymers, polyethylene glycol (PEG) has been most extensively used for this purpose [41; 55]. Lipid nanoparticles including liposomes can be pegylated by anchoring PEG-phospholipids or PEG-lipids. Pegylation of polymeric nanoparticles can be achieved by adhering surfactants like poloxamers or polysorbates onto nanoparticles, or by formulating nanoparticles with copolymers comprising PEG and a biodegradable moiety. Due to the highly flexible, well-hydrated nature of PEG chains, the PEG layer forms a water cloud, i.e., a considerable exclusion volume [44]. The water cloud represents a minimal interfacial free energy, leading to reduction in attraction force towards environmental proteins including opsonins. In fact, a number of studies have demonstrated that pegylation of particulate carriers results

in dramatically reduced RES uptake and prolonged circulation half-life.

The second dose of pegylated liposomes after several days interval exhibits a significantly faster clearance from blood as compared to the first dose, being referred to as the “accelerated blood clearance (ABC) phenomenon” [56; 57; 58]. It is attributed to production of anti-PEG IgM from spleen in response to an injected dose of pegylated liposomes. Anti-PEG IgM leads to opsonization of a second dose of pegylated liposomes by C3 fragments and enhanced uptake by the Kupffer cells in liver. This phenomenon is observed with “empty” pegylated liposomes, but not with doxorubicin-containing liposomes since doxorubicin inhibits the proliferation of B cells in the spleen [59]. Regarding drugs other than antiproliferative agents (e.g., nucleic acids), caution should be paid to the ABC phenomenon [60].

4. Enhanced permeability retention (EPR) effect for tumor drug targeting

In a wide range of disorders such as solid tumors and inflammation tissues, pathological angiogenesis occurs. Abnormal microvascular proliferation results in production of immature and fragile blood vessels. Various vascular mediators such as bradykinin, nitric oxide, and prostaglandins induce extensive vascular permeability [22]. Passive targeting is a localized drug delivery technique to exploit pathophysiological vascular architecture of tumors and inflammation tissues. In comparison to the normal tissues, tumor microvascular endothelium exhibits elevated permeability to macromolecules. Along with lack of lymphatic drainage, extravasated macromolecules accumulate in tumor tissues for long periods. This is called “enhanced permeability and retention” (EPR) effect [21; 22] (Figure 2).

(Figure 2)

The first demonstration of the EPR effect was done with SMANCS/Lipiodol [21; 22]. When SMANCS/Lipiodol is infused intraarterially, a significantly high tumor/blood ratio of the drug can be obtained. Thereafter, the EPR effect has been observed with various polymer conjugates such as dextran [61; 62], albumin [63; 64], poly(hydroxypropylmethacrylamide) (HPMA) copolymer [65; 66], polyethylene glycol [67; 68], and polyvinyl alcohol [69]. Although they are mostly investigated in rodents, PK1 (HPMA-doxorubicin conjugate) has been shown to achieve response rates of 21% and 11.5% in patients with metastatic breast and lung cancer,

respectively [70]. Although not polymer conjugates, Doxil, which is a pegylated liposome that encapsulates doxorubicin, was approved for the treatment of Kaposi sarcoma and late stage ovarian cancer. Abraxane is a paclitaxel nanoparticle consisting of strongly albumin-bound paclitaxel, which is intended for metastatic breast cancer.

Although several commercial products exploiting the EPR effect have already been launched, it has been pointed out that translational research in EPR-based medicines is too slow [71]. Possible reasons raised were dilemmas in uptake and drug release, substantially low targeting efficiency, validity of animal models, and biological diversity of tumors [71]. Stealth properties of the nanocarriers are not exceptional for target tumor cells; that is, their hydrophilic shells prevent interaction with tumor cells as well as do so with opsonins and phagocytes. A similar dilemma exists in drug release. If active drugs were stably associated or conjugated with carriers, drug release would be slow in both the systemic circulation and the target tissue. In tumor tissues, convective transport is limited due to high internal fluid pressure [72]. Therefore, it is ideal that active drugs, having higher diffusivity than drug carriers, are efficiently released once the carriers reach tumor tissues. To solve these problems, target-site specific machineries for drug release might have to be implemented in carrier systems [73; 74]. Another point raised is that, with success of EPR-based targeting, accumulation of active drug inside the tumor rarely exceeds 5% of the injected dose [71; 75]. However, the tumor/blood (T/B) concentration ratio would rather be an important measure from the pharmacokinetic/pharmacodynamic point of view, since concentration (but not amount) of active drug determines intensity of pharmacological and toxicological response. The most critical point appears to be difference in the progression rate of tumors between animal models and human patients. The authors cautioned that the EPR effect is emphasized in animal xenograft models producing a large quantity of VEGF and vascular mediators [71; 75].

5. Control of drug release from polymer conjugates

Prodrug linkers have been designed to effectively release a parent drug at the target site. Commonly used linkers include ester, amide, disulfide, and imine/hydrazone [76]. Ester bonds are the most common linkages in prodrug design,

since carboxy and hydroxy groups are available in most parent drugs. The ester bonds would often be inappropriate because they can easily be hydrolyzed by esterase ubiquitously distributed in the body. Amide bonds, which are another commonly used linkage, exhibit relatively higher enzyme stability than ester bonds. Target-specific drug release can be achieved by paying attention to physiological and biochemical differences between target and non-target tissues. The differences include expression of specific enzymes, interstitial or intracellular pH, and redox balance [73; 74].

Peptide linkers are cleaved selectively by tissue-specific enzymes and liberate the parent drug at the target site [77; 78; 79]. Lysosomal cysteine proteases such as cathepsin B are overexpressed in tumor cells [80]. In the study of lysosomotropic modified dextran-doxorubicin conjugates, the concentration of liberated doxorubicin in the tumor was gradually increased over 48 h following intravenous injection, whereas that in the plasma was negligibly small [79]. When two dextran-doxorubicin conjugates having GGFG and GGIG peptide linkers were compared, in vitro release rate of liberated doxorubicin from the conjugates in tumor cell homogenates was 10-fold different, whilst in vivo concentration profiles for liberated doxorubicin, as well as those for the conjugates, were similar in both conjugates after intravenous injection [79]. The in vitro-in vivo discrepancy can be explained by assuming that uptake of the conjugates by tumor cell is much slower than release of doxorubicin from the conjugates. It has also been demonstrated that both conjugates showed significant anti-tumor activity in tumor-bearing mice but the conjugate having GGPG linker did not [79]. Peptide linkers sensitive to matrix metalloprotease-2 (MMP-2) and MMP-9 were also found to be effective for tumorotropic drug delivery. Dextran-methotrexate conjugate with the PVGLIG linker was much less toxic in the small intestine and bone marrow than that with a MMP-insensitive GIVGPL linker, while both conjugates significantly inhibited tumor growth [62]. The hydrazone bond is relatively stable at neutral pH, but it undergoes hydrolysis at acidic pH (pH4.5-6.5). Therefore, macromolecular prodrugs with such an acid-cleavable linker can release the parent drug in endosomal compartments following internalization into the cell interior. Prostaglandin E1 covalently bonded to lactosylated poly(L-glutamic hydrazide) is efficiently released after internalization into hepatocytes, and exhibits a significant anti-inflammatory effect in mice with fulminant hepatitis [81]. Various acid-cleavable linkers have been introduced to be available for site-specific drug release in tumors [82] and rheumatoid arthritis [83]. Generally, cleavage rate and sensitivity of

acid-responsive linkers are variable for each conjugate, and in some cases cleavage at the site other than hydrazine bond occurs [84; 85]. Since the cleavage rate of linkers is critical in therapeutic efficacy of conjugates, the linkers need to be carefully designed and evaluated.

6. Acceleration of delivery of drugs to organs and tissues

6.1. Enhanced delivery by cationization

Alteration of net charge by chemical modification is also an effective approach for targeted delivery of protein drugs (Figure 1). It is known that large-molecular-weight, cationic macromolecules tend to accumulate rapidly in the liver [61; 86], even though they might interact with blood components. The liver sinusoids possess a number of fenestrae with mean diameter of approximately 100 nm and lack a diaphragm and a basal lamina underneath the endothelium. Due to the specialized vascular structure, macromolecules are freely accessible to parenchymal cells. Therefore, cationic macromolecules are rapidly taken up by the liver, primarily hepatocytes, via electrostatic interaction with negatively charged cell surfaces. Although slower than that observed in receptor-mediated endocytosis, massive internalization of the proteins into the cell interior occurs by absorptive endocytosis [86]. Hepatic targeting of cationic derivatives of dextran bearing mitomycin C [61] and superoxide dismutase [87] has been reported.

On the other hand, cationic molecules that are small enough to undergo glomerular filtration can be taken up by the kidney not only from the capillary side but from the luminal side. Superoxide dismutase cationized within such an extent that the loss of activity is acceptable is taken up by the kidney more effectively than native superoxide dismutase [88]. It exhibits much greater therapeutic potency against kidney ischemia/reperfusion injury in rats [89].

6.2. Receptor-mediated delivery of therapeutic proteins

Glycoconjugates have been extensively studied for active targeting of protein drugs to specific cell types. Liver parenchymal cells, i.e., hepatocytes, express exclusively asialoglycoprotein receptors, which recognize galactose terminal

residues of glycoproteins. Although the targeting efficiency depends on the molecular size of a protein drug and the number of galactose moieties conjugated [90; 91], galactosylated proteins are almost completely delivered to hepatocytes. The hepatic uptake clearances for galactosylated proteins are almost the same as hepatic plasma flow [90; 91], indicating that the uptake rates by hepatocytes are much higher than the hepatic plasma flow. Conjugation with mannose or fucose enables delivery of the protein to antigen-presenting cells, e.g., macrophages and dendritic cells, expressing specialized receptors [16; 92; 93; 94]. When mannosylated and fucosylated proteins are injected intravenously, they also rapidly distribute to the liver but to different cell types than galactosylated proteins. Mannosylated bovine serum albumin (Man-BSA) is taken up by liver endothelial cells and Kupffer cells, and fucosylated BSA is taken up more specifically by Kupffer cells [95]. Kupffer cells, which are the resident macrophages of the liver, produce ROS and release lysosomal enzymes by various pathophysiological stimuli including ischemia-reperfusion and septic shock. Mannosylated and fucosylated catalase following intravenous injection were found to be effective for these ROS-mediated injuries [16; 92; 93; 94].

Highly negatively charged molecules are recognized by scavenger receptors expressed on a variety of cells including macrophages, Kupffer cells, and sinusoidal endothelial cells. Proteins modified with maleic acid or succinic acid are ligands for the scavenger receptors, which are also rapidly taken up by the liver [93; 94; 96]. A physiological pharmacokinetic model, involving a saturable process with Michaelis-Menten kinetics, revealed that the surface density of negative charges was correlated with the affinity of succinylated proteins for the hepatic scavenger receptors [96]. These results also provide a caution towards chemical modification of proteins. The amino group of lysine residue is the first choice for chemical modification. Reaction at the amino group usually reduces a positive charge or increases net negative charge of proteins. In fact, conjugation of para-aminophenyl-mannopyranoside to albumin with thiophosgen increased net negative charge with an increase in sugar density, resulting in greater affinity to scavenger receptor than to mannose receptor [97]. When lysine residues are modified, the ratio of modification should be minimal or the modification method that leaves unchanged net charge of a protein molecule should be selected.

6.3. Receptor-mediated delivery of particulate carriers

Receptor-mediated endocytic pathways have been exploited for cell-specific delivery of particulate carriers. Due to their sufficient size, particulate carriers have the potential of being modified with a variety of functional molecules ranging from small organic molecules to proteins. Representative proteins intended as a targeting ligand includes transferrin [98; 99], asialoglycoproteins [100], apolipoproteins [101], and antibodies [102]. Homing peptides, including synthetic peptides identified by phage display or other screening techniques, have also been used as a targeting ligand [103]. The advantages of using peptides instead of proteins include more reproducible preparations and lower immunogenicity. Carbohydrates [104; 105] and nucleic acids (i.e., aptamers) [106; 107] have also been exploited for targeted drug delivery of particulate carriers. Two transferrin-modified nanoparticles, i.e., CALAA-01 (cyclodextrin polymer-based nanoparticles containing ribonucleotide reductase siRNA) [108] and MBP-426 (liposomes containing oxaliplatin) [109], are now under clinical trials for the treatment of malignant tumors.

Efficiency of active targeting with particulate carriers depends on biophysical interactions at different layers. At the level of the particle-membrane interface, specific (ligand-receptor) and nonspecific interactions must decrease the free energy at the contact site to overcome the resistive forces that hinder particle uptake (e.g., stretching and elasticity of cell membrane) [110]. Mathematical models to describe the thermodynamics of receptor-mediated endocytosis have been proposed, which consider specific and nonspecific interactions, diffusion of the receptors in membrane, and elastic bending of the membrane [111; 112]. The models can relate endocytic performance of nanoparticles to the particle size, the ligand density, etc. Although the exact mechanism remains unclear, it has been known that two galactosylated liposomes that contain the same amount of galactosylated cholesterol derivative but vary in the ratio of distearoylphosphatidylcholine and cholesterol exhibit different internalization rates in HepG2 cells [113]. Biophysical characteristics of the liposome carriers, e.g., elasticity and fluidity, would be an important factor in determining cellular uptake. Effect of ligand density on cellular uptake has been investigated with galactosylated liposomes [114]. In vitro cellular uptake of the galactosylated liposomes was not changed up to 2.5 mol% galactolipid, but increased linearly from 2.5 to 7.5 mol% (the highest tested).

At the organ/tissue level, effect of physiological parameters such as the blood flow must be considered. If the intrinsic capacity of receptor-mediated uptake is

sufficiently high, the delivery rate becomes equal to the blood flow. In fact, in vivo pharmacokinetic analysis has demonstrated that hepatic uptake clearance of the galactosylated liposomes containing 5.0 mol% or higher galactolipid is almost the same as the hepatic blood flow. It should also be noted that the ligand-receptor interaction is a saturable process. In vivo hepatic uptake clearance of galactosylated liposomes decreases at a higher dose [115]. This means that the rate-limiting step in the hepatic uptake changes from the blood flow to the intrinsic uptake clearance due to the saturation of the ligand-receptor interaction. Moreover, at a high dose, the galactosylated liposomes are taken up by non-parenchymal cells rather than by hepatocytes, and can inhibit the uptake of mannosylated and fucosylated liposomes [115]. This indicates that contribution of the low-affinity high-capacity pathway is not negligible under saturation of the main pathway.

6.4. Pharmacokinetic considerations of receptor-mediated drug delivery

Receptor-mediated drug targeting to the liver is relatively easier than to other organs and tissues. Ligand-receptor interactions are possible only when the two components are in close proximity (<0.5nm) [75]. Due to unique vascular structures of the liver, drug carriers are freely accessible to all cell types in the liver. Therefore, overall probability for a ligand-bearing drug carrier to be taken up by the receptor is much higher for the liver than for the tissues where the blood flow is poor and vascular permeability of the carrier is restricted.

Figure 3 represents overall probability for carriers to be taken up into the cell interior. The total process for movement from the systemic blood vessel to the cell interior consists of kinetic steps connected in a serial manner. According to a well-stirred model, the extraction ratio (E_i) in the i -th organ is expressed as:

$$E_i = \frac{P_{in,i} \cdot \left(\frac{U_{in,i}}{P_{out,i} + U_{in,i}} \right)}{Q_{out,i} + P_{in,i} \cdot \left(\frac{U_{in,i}}{P_{out,i} + U_{in,i}} \right)} = \frac{1}{1 + \frac{Q_{out,i}}{P_{in,i}} \cdot \left(1 + \frac{P_{out,i}}{U_{in,i}} \right)} \quad (4)$$

where $Q_{out,i}$, $P_{in,i}$, $P_{out,i}$, and $U_{in,i}$ are blood flow rate, influx permeability across endothelium, efflux permeability across endothelium, and intrinsic clearance for cellular uptake, respectively. As endothelial permeability ($P_{out,i}$) is higher, E_i is more sensitive to U_i . Since endothelial permeability is sufficiently high in the liver,

benefits of exploiting receptor-mediated uptake mechanism for enhanced drug delivery is more pronounced than in other organs. This is the reason why delivery directed to hepatocytes using specific ligands is effective. If the receptor-mediated uptake is also high enough, the E_i becomes unity, suggesting that the blood flow is rate-limiting.

How about application of active targeting techniques to tumor targeting? There are several reviews dealing with this topic [75; 116; 117], but we are going to explain it from the pharmacokinetic point of view. It is meaningful at least to take up extravasated drug carriers in a concentrative manner. It depends on the balance of $P_{out,i}$ vs. U_i whether or not extravasation of circulating drug carriers is accelerated by exploiting active targeting techniques. If looks at Eq. 4, one can realize that as efflux permeability ($P_{out,i}$) is higher, application of active targeting is more meaningful. However, it cannot be expected so much. EPR-based medicines continue to accumulate slowly into tumor over a few days in spite that their plasma concentration gradually decreases. Possible reasons why the tumor uptake did not reach plateau within the days include slow vascular efflux permeability, in addition to large distribution volume of tumor relative to blood flow. If vascular efflux permeability is slow, application of active targeting techniques would not work well, as suggested from Eq. 4. In fact, it has been reported that introduction of targeting ligands to pegylated nanoparticles sometimes show no effects on pharmacokinetics [118] or attenuates their stealth function [119]. On the other hands, if relative tumor volume against blood flow is large (that is, tumor tissue is poorly perfused), chemotherapy itself is difficult. It has generally been known that tumors vasculature is highly irregular and heterogeneous [72; 120]. Insufficient blood supply induces nutrient deprivation and subsequently cell cycle arrest. In other words, the rate of proliferation of tumor cells is slower in poorly-perfused region than in well-perfused region [72; 120]. Tumor cells distally located from blood vessels is inevitably resistant to chemotherapeutic agents that target cell proliferation [120]. When delivery of the agents to the region is poor, it is extremely difficult to kill distal tumor cells.

7. Conclusions and future directions

To precisely control drug disposition behavior by the use of drug delivery technologies, thorough understandings of pharmacokinetic characteristics at the

whole body, organ, and cellular levels are required. Undoubtedly, clearance concept-based pharmacokinetic analyses have been contributing to exploring biodistribution of macromolecular and particulate drug carriers quantitatively in relation to their physicochemical and biological characteristics and developing a strategy for rational design of targeted drug delivery system. Ideally, however, optimization of therapy should be done based not only on pharmacokinetics but on pharmacodynamics. With the progress of molecular pharmacokinetics/pharmacodynamics (PK/PD) analyses, PK/PD modeling has been developing from a descriptive to a mechanism-based approach. In other words, relevant processes on the causal-effect link between drug administration and drug effect are recently being considered in PK/PD modeling. Moreover, systems biology and systems pharmacology are expected to provide new information on identification of multiple targets against complex diseases. Development of drug delivery system will, in near future, deal with “when, where and what should be delivered”. Therefore, it is essential that fundamental research be carried out to address these issues. The future of drug delivery system will depend on rational design of nanotechnology materials and methods based on a detailed and thorough understanding of biological processes.

References

- [1] K.B. Bischoff, and R.L. Dedrick, Thiopental pharmacokinetics. *J Pharm Sci* 57 (1968) 1346-51.
- [2] K.B. Bischoff, R.L. Dedrick, D.S. Zaharko, and J.A. Longstreth, Methotrexate pharmacokinetics. *J Pharm Sci* 60 (1971) 1128-33.
- [3] M. Rowland, L.Z. Benet, and G.G. Graham, Clearance concepts in pharmacokinetics. *J Pharmacokinetic Biopharm* 1 (1973) 123-36.
- [4] Y. Takakura, and M. Hashida, Macromolecular carrier systems for targeted drug delivery: pharmacokinetic considerations on biodistribution. *Pharm Res* 13 (1996) 820-31.
- [5] M. Nishikawa, Y. Takakura, and M. Hashida, Theoretical considerations involving the pharmacokinetics of plasmid DNA. *Adv Drug Deliv Rev* 57 (2005) 675-88.
- [6] M. Nishikawa, F. Staud, S. Takemura, Y. Takakura, and M. Hashida, Pharmacokinetic evaluation of biodistribution data obtained with radiolabeled proteins in mice. *Biol Pharm Bull* 22 (1999) 214-8.

- [7] M.P. Bohrer, C. Baylis, H.D. Humes, R.J. Glassock, C.R. Robertson, and B.M. Brenner, Permselectivity of the glomerular capillary wall. Facilitated filtration of circulating polycations. *J Clin Invest* 61 (1978) 72-8.
- [8] R.L. Chang, W.M. Deen, C.R. Robertson, and B.M. Brenner, Permselectivity of the glomerular capillary wall: III. Restricted transport of polyanions. *Kidney Int* 8 (1975) 212-8.
- [9] J. Wartiovaara, L.G. Ofverstedt, J. Khoshnoodi, J. Zhang, E. Mäkelä, S. Sandin, V. Ruotsalainen, R.H. Cheng, H. Jalanko, U. Skoglund, and K. Tryggvason, Nephrin strands contribute to a porous slit diaphragm scaffold as revealed by electron tomography. *J Clin Invest* 114 (2004) 1475-83.
- [10] H.S. Choi, W. Liu, P. Misra, E. Tanaka, J.P. Zimmer, B. Itty Ipe, M.G. Bawendi, and J.V. Frangioni, Renal clearance of quantum dots. *Nat Biotechnol* 25 (2007) 1165-70.
- [11] H. Birn, and E.I. Christensen, Renal albumin absorption in physiology and pathology. *Kidney Int* 69 (2006) 440-9.
- [12] L.M. Russo, R.M. Sandoval, M. McKee, T.M. Osicka, A.B. Collins, D. Brown, B.A. Molitoris, and W.D. Comper, The normal kidney filters nephrotic levels of albumin retrieved by proximal tubule cells: retrieval is disrupted in nephrotic states. *Kidney Int* 71 (2007) 504-13.
- [13] D.S. Pisal, M.P. Kosloski, and S.V. Balu-Iyer, Delivery of therapeutic proteins. *J Pharm Sci* 99 (2010) 2557-75.
- [14] J. Heathcote, and S. Zeuzem, Pegylated interferon monotherapy for chronic hepatitis C. *Semin Liver Dis* 24 Suppl 2 (2004) 39-45.
- [15] G. Molineux, The design and development of pegfilgrastim (PEG-rmetHuG-CSF, Neulasta). *Curr Pharm Des* 10 (2004) 1235-44.
- [16] Y. Yabe, M. Nishikawa, A. Tamada, Y. Takakura, and M. Hashida, Targeted delivery and improved therapeutic potential of catalase by chemical modification: combination with superoxide dismutase derivatives. *J Pharmacol Exp Ther* 289 (1999) 1176-84.
- [17] K. Hyoudou, M. Nishikawa, Y. Kobayashi, Y. Kuramoto, F. Yamashita, and M. Hashida, Inhibition of adhesion and proliferation of peritoneally disseminated tumor cells by pegylated catalase. *Clin Exp Metastasis* 23 (2006) 269-78.
- [18] K. Hyoudou, M. Nishikawa, M. Ikemura, Y. Kobayashi, A. Mendelsohn, N. Miyazaki, Y. Tabata, F. Yamashita, and M. Hashida, Prevention of pulmonary metastasis from subcutaneous tumors by binary system-based sustained delivery of catalase. *J Control Release* 137 (2009) 110-5.
- [19] M. Nishikawa, A. Tamada, H. Kumai, F. Yamashita, and M. Hashida, Inhibition of experimental pulmonary metastasis by controlling biodistribution of catalase in

- mice. *Int J Cancer* 99 (2002) 474-9.
- [20] M. Ikemura, M. Nishikawa, K. Hyoudou, Y. Kobayashi, F. Yamashita, and M. Hashida, Improvement of insulin resistance by removal of systemic hydrogen peroxide by PEGylated catalase in obese mice. *Mol Pharm* 7 (2010) 2069-76.
- [21] H. Maeda, J. Wu, T. Sawa, Y. Matsumura, and K. Hori, Tumor vascular permeability and the EPR effect in macromolecular therapeutics: a review. *J Control Release* 65 (2000) 271-84.
- [22] H. Maeda, The enhanced permeability and retention (EPR) effect in tumor vasculature: the key role of tumor-selective macromolecular drug targeting. *Adv Enzyme Regul* 41 (2001) 189-207.
- [23] R. Igarashi, J. Hoshino, A. Ochiai, Y. Morizawa, and Y. Mizushima, Lecithinized superoxide dismutase enhances its pharmacologic potency by increasing its cell membrane affinity. *J Pharmacol Exp Ther* 271 (1994) 1672-7.
- [24] T. Ishihara, K. Tanaka, Y. Tasaka, T. Namba, J. Suzuki, S. Okamoto, T. Hibi, M. Takenaga, R. Igarashi, K. Sato, Y. Mizushima, and T. Mizushima, Therapeutic effect of lecithinized superoxide dismutase against colitis. *J Pharmacol Exp Ther* 328 (2009) 152-64.
- [25] M. Takenaga, Y. Ohta, Y. Tokura, A. Hamaguchi, M. Nakamura, H. Okano, and R. Igarashi, Lecithinized superoxide dismutase (PC-SOD) improved spinal cord injury-induced motor dysfunction through suppression of oxidative stress and enhancement of neurotrophic factor production. *J Control Release* 110 (2006) 283-9.
- [26] G.H. Tomkin, Albiglutide, an albumin-based fusion of glucagon-like peptide 1 for the potential treatment of type 2 diabetes. *Curr Opin Mol Ther* 11 (2009) 579-88.
- [27] V.K. Rustgi, Albinterferon alfa-2b, a novel fusion protein of human albumin and human interferon alfa-2b, for chronic hepatitis C. *Curr Med Res Opin* 25 (2009) 991-1002.
- [28] S. Ikuta, V.T. Chuang, Y. Ishima, K. Nakajou, M. Furukawa, H. Watanabe, T. Maruyama, and M. Otagiri, Albumin fusion of thioredoxin--the production and evaluation of its biological activity for potential therapeutic applications. *J Control Release* 147 (2010) 17-23.
- [29] R. Stork, E. Campigna, B. Robert, D. Müller, and R.E. Kontermann, Biodistribution of a bispecific single-chain diabody and its half-life extended derivatives. *J Biol Chem* 284 (2009) 25612-9.
- [30] Y. Jing, H. Lu, K. Wu, I.V. Subramanian, and S. Ramakrishnan, Inhibition of ovarian cancer by RGD-P125A-endostatin-Fc fusion proteins. *Int J Cancer* 129 (2011) 751-61.
- [31] L. Cao, P. Du, S.H. Jiang, G.H. Jin, Q.L. Huang, and Z.C. Hua, Enhancement of

- antitumor properties of TRAIL by targeted delivery to the tumor neovasculature. *Mol Cancer Ther* 7 (2008) 851-61.
- [32] P. Opanasopit, M. Nishikawa, and M. Hashida, Factors affecting drug and gene delivery: effects of interaction with blood components. *Crit Rev Ther Drug Carrier Syst* 19 (2002) 191-233.
- [33] P.R. Cullis, A. Chonn, and S.C. Semple, Interactions of liposomes and lipid-based carrier systems with blood proteins: Relation to clearance behaviour in vivo. *Adv Drug Deliv Rev* 32 (1998) 3-17.
- [34] P. Opanasopit, Y. Higuchi, S. Kawakami, F. Yamashita, M. Nishikawa, and M. Hashida, Involvement of serum mannan binding proteins and mannose receptors in uptake of mannosylated liposomes by macrophages. *Biochim Biophys Acta* 1511 (2001) 134-45.
- [35] T. Terada, M. Nishikawa, F. Yamashita, and M. Hashida, Influence of cholesterol composition on the association of serum mannan-binding proteins with mannosylated liposomes. *Biol Pharm Bull* 29 (2006) 613-8.
- [36] K. Ogawara, K. Furumoto, S. Nagayama, K. Minato, K. Higaki, T. Kai, and T. Kimura, Pre-coating with serum albumin reduces receptor-mediated hepatic disposition of polystyrene nanosphere: implications for rational design of nanoparticles. *J Control Release* 100 (2004) 451-5.
- [37] K. Maruyama, A. Mori, S. Bhadra, M.T. Subbiah, and L. Huang, Proteins and peptides bound to long-circulating liposomes. *Biochim Biophys Acta* 1070 (1991) 246-52.
- [38] A. Chonn, S.C. Semple, and P.R. Cullis, Association of blood proteins with large unilamellar liposomes in vivo. Relation to circulation lifetimes. *J Biol Chem* 267 (1992) 18759-65.
- [39] K. Ogawara, M. Yoshida, J. Kubo, M. Nishikawa, Y. Takakura, M. Hashida, K. Higaki, and T. Kimura, Mechanisms of hepatic disposition of polystyrene microspheres in rats: effects of serum depend on the sizes of microspheres. *J Control Release* 61 (1999) 241-50.
- [40] H. Ayhan, A. Tuncel, N. Bor, and E. Pişkin, Phagocytosis of monosize polystyrene-based microspheres having different size and surface properties. *J Biomater Sci Polym Ed* 7 (1995) 329-42.
- [41] H. Hillaireau, and P. Couvreur, Nanocarriers' entry into the cell: relevance to drug delivery. *Cell Mol Life Sci* 66 (2009) 2873-96.
- [42] H. Harashima, K. Sakata, K. Funato, and H. Kiwada, Enhanced hepatic uptake of liposomes through complement activation depending on the size of liposomes. *Pharm Res* 11 (1994) 402-6.
- [43] A. Vonarbourg, C. Passirani, P. Saulnier, P. Simard, J.C. Leroux, and J.P. Benoit,

- Evaluation of pegylated lipid nanocapsules versus complement system activation and macrophage uptake. *J Biomed Mater Res A* 78 (2006) 620-8.
- [44] A. Vonarbourg, C. Passirani, P. Saulnier, and J.P. Benoit, Parameters influencing the stealthiness of colloidal drug delivery systems. *Biomaterials* 27 (2006) 4356-73.
- [45] R.L. Juliano, and D. Stamp, The effect of particle size and charge on the clearance rates of liposomes and liposome encapsulated drugs. *Biochem Biophys Res Commun* 63 (1975) 651-8.
- [46] G. Gregoriadis, and B.E. Ryman, Lysosomal localization of -fructofuranosidase-containing liposomes injected into rats. *Biochem J* 129 (1972) 123-33.
- [47] K.D. Lee, R.E. Pitas, and D. Papahadjopoulos, Evidence that the scavenger receptor is not involved in the uptake of negatively charged liposomes by cells. *Biochim Biophys Acta* 1111 (1992) 1-6.
- [48] K. Nishikawa, H. Arai, and K. Inoue, Scavenger receptor-mediated uptake and metabolism of lipid vesicles containing acidic phospholipids by mouse peritoneal macrophages. *J Biol Chem* 265 (1990) 5226-31.
- [49] A.J. Bradley, D.E. Brooks, R. Norris-Jones, and D.V. Devine, C1q binding to liposomes is surface charge dependent and is inhibited by peptides consisting of residues 14-26 of the human C1qA chain in a sequence independent manner. *Biochim Biophys Acta* 1418 (1999) 19-30.
- [50] H. Chen, R. Langer, and D.A. Edwards, A Film Tension Theory of Phagocytosis. *J Colloid Interface Sci* 190 (1997) 118-33.
- [51] K. Furumoto, K. Ogawara, S. Nagayama, Y. Takakura, M. Hashida, K. Higaki, and T. Kimura, Important role of serum proteins associated on the surface of particles in their hepatic disposition. *J Control Release* 83 (2002) 89-96.
- [52] R.L. Juliano, D. Stamp, and N. McCullough, Pharmacokinetics of liposome-encapsulated antitumor drugs and implications for therapy. *Ann N Y Acad Sci* 308 (1978) 411-25.
- [53] U. Scheffel, B.A. Rhodes, T.K. Natarajan, and H.N. Wagner, Albumin microspheres for study of the reticuloendothelial system. *J Nucl Med* 13 (1972) 498-503.
- [54] I. Sjöholm, and P. Edman, Acrylic microspheres in vivo. I. Distribution and elimination of polyacrylamide microparticles after intravenous and intraperitoneal injection in mouse and rat. *J Pharmacol Exp Ther* 211 (1979) 656-62.
- [55] G. Pasut, and F.M. Veronese, State of the art in PEGylation: The great versatility achieved after forty years of research. *J Control Release* (2011).
- [56] T. Ishida, and H. Kiwada, Accelerated blood clearance (ABC) phenomenon upon

- repeated injection of PEGylated liposomes. *Int J Pharm* 354 (2008) 56-62.
- [57] E.T. Dams, P. Laverman, W.J. Oyen, G. Storm, G.L. Scherphof, J.W. van Der Meer, F.H. Corstens, and O.C. Boerman, Accelerated blood clearance and altered biodistribution of repeated injections of sterically stabilized liposomes. *J Pharmacol Exp Ther* 292 (2000) 1071-9.
- [58] T. Ishida, R. Maeda, M. Ichihara, Y. Mukai, Y. Motoki, Y. Manabe, K. Irimura, and H. Kiwada, The accelerated clearance on repeated injection of pegylated liposomes in rats: laboratory and histopathological study. *Cell Mol Biol Lett* 7 (2002) 286.
- [59] T. Ishida, K. Atobe, X. Wang, and H. Kiwada, Accelerated blood clearance of PEGylated liposomes upon repeated injections: effect of doxorubicin-encapsulation and high-dose first injection. *J Control Release* 115 (2006) 251-8.
- [60] T. Tagami, K. Nakamura, T. Shimizu, N. Yamazaki, T. Ishida, and H. Kiwada, CpG motifs in pDNA-sequences increase anti-PEG IgM production induced by PEG-coated pDNA-lipoplexes. *J Control Release* 142 (2010) 160-6.
- [61] Y. Takakura, T. Fujita, M. Hashida, and H. Sezaki, Disposition characteristics of macromolecules in tumor-bearing mice. *Pharm Res* 7 (1990) 339-46.
- [62] Y. Chau, N.M. Dang, F.E. Tan, and R. Langer, Investigation of targeting mechanism of new dextran-peptide-methotrexate conjugates using biodistribution study in matrix-metalloproteinase-overexpressing tumor xenograft model. *J Pharm Sci* 95 (2006) 542-51.
- [63] F. Kratz, R. Müller-Driver, I. Hofmann, J. Dreves, and C. Unger, A novel macromolecular prodrug concept exploiting endogenous serum albumin as a drug carrier for cancer chemotherapy. *J Med Chem* 43 (2000) 1253-6.
- [64] A.M. Burger, G. Hartung, G. Stehle, H. Sinn, and H.H. Fiebig, Pre-clinical evaluation of a methotrexate-albumin conjugate (MTX-HSA) in human tumor xenografts in vivo. *Int J Cancer* 92 (2001) 718-24.
- [65] Y. Noguchi, J. Wu, R. Duncan, J. Strohal, K. Ulbrich, T. Akaike, and H. Maeda, Early phase tumor accumulation of macromolecules: a great difference in clearance rate between tumor and normal tissues. *Jpn J Cancer Res* 89 (1998) 307-14.
- [66] P.M. Loadman, M.C. Bibby, J.A. Double, W.M. Al-Shakhaa, and R. Duncan, Pharmacokinetics of PK1 and doxorubicin in experimental colon tumor models with differing responses to PK1. *Clin Cancer Res* 5 (1999) 3682-8.
- [67] M. Pechar, K. Ulbrich, V. Subr, L.W. Seymour, and E.H. Schacht, Poly(ethylene glycol) multiblock copolymer as a carrier of anti-cancer drug doxorubicin. *Bioconjug Chem* 11 (2000) 131-9.
- [68] R. Tomlinson, J. Heller, S. Brocchini, and R. Duncan, Polyacetal-doxorubicin conjugates

- designed for pH-dependent degradation. *Bioconjug Chem* 14 (2003) 1096-106.
- [69] A. Kakinoki, Y. Kaneo, T. Tanaka, and Y. Hosokawa, Synthesis and evaluation of water-soluble poly(vinyl alcohol)-paclitaxel conjugate as a macromolecular prodrug. *Biol Pharm Bull* 31 (2008) 963-9.
- [70] L.W. Seymour, D.R. Ferry, D.J. Kerr, D. Rea, M. Whitlock, R. Poyner, C. Boivin, S. Hesslewood, C. Twelves, R. Blackie, A. Schatzlein, D. Jodrell, D. Bissett, H. Calvert, M. Lind, A. Robbins, S. Burtles, R. Duncan, and J. Cassidy, Phase II studies of polymer-doxorubicin (PK1, FCE28068) in the treatment of breast, lung and colorectal cancer. *Int J Oncol* 34 (2009) 1629-36.
- [71] S. Taurin, H. Nehoff, and K. Greish, Anticancer nanomedicine and tumor vascular permeability; Where is the missing link? *J Control Release* (2012).
- [72] R.K. Jain, Determinants of tumor blood flow: a review. *Cancer Res* 48 (1988) 2641-58.
- [73] T.L. Andresen, D.H. Thompson, and T. Kaasgaard, Enzyme-triggered nanomedicine: drug release strategies in cancer therapy. *Mol Membr Biol* 27 (2010) 353-63.
- [74] E. Fleige, M.A. Quadir, and R. Haag, Stimuli-responsive polymeric nanocarriers for the controlled transport of active compounds: concepts and applications. *Adv Drug Deliv Rev* 64 (2012) 866-84.
- [75] Y.H. Bae, and K. Park, Targeted drug delivery to tumors: myths, reality and possibility. *J Control Release* 153 (2011) 198-205.
- [76] R. Mahato, W. Tai, and K. Cheng, Prodrugs for improving tumor targetability and efficiency. *Adv Drug Deliv Rev* 63 (2011) 659-70.
- [77] P.A. Vasey, S.B. Kaye, R. Morrison, C. Twelves, P. Wilson, R. Duncan, A.H. Thomson, L.S. Murray, T.E. Hilditch, T. Murray, S. Burtles, D. Fraier, E. Frigerio, and J. Cassidy, Phase I clinical and pharmacokinetic study of PK1 [N-(2-hydroxypropyl)methacrylamide copolymer doxorubicin]: first member of a new class of chemotherapeutic agents-drug-polymer conjugates. Cancer Research Campaign Phase I/II Committee. *Clin Cancer Res* 5 (1999) 83-94.
- [78] Y. Shiose, Y. Ochi, H. Kuga, F. Yamashita, and M. Hashida, Relationship between drug release of DE-310, macromolecular prodrug of DX-8951f, and cathepsins activity in several tumors. *Biol Pharm Bull* 30 (2007) 2365-70.
- [79] Y. Shiose, H. Kuga, H. Ohki, M. Ikeda, F. Yamashita, and M. Hashida, Systematic research of peptide spacers controlling drug release from macromolecular prodrug system, carboxymethyl dextran polyalcohol-peptide-drug conjugates. *Bioconjug Chem* 20 (2009) 60-70.
- [80] C. Palermo, and J.A. Joyce, Cysteine cathepsin proteases as pharmacological targets in cancer. *Trends Pharmacol Sci* 29 (2008) 22-8.

- [81] K. Akamatsu, Y. Yamasaki, M. Nishikawa, Y. Takakura, and M. Hashida, Synthesis and pharmacological activity of a novel water-soluble hepatocyte-specific polymeric prodrug of prostaglandin E(1) using lactosylated poly(L-glutamic hydrazide) as a carrier. *Biochem Pharmacol* 62 (2001) 1531-6.
- [82] F. Kratz, U. Beyer, and M.T. Schütte, Drug-polymer conjugates containing acid-cleavable bonds. *Crit Rev Ther Drug Carrier Syst* 16 (1999) 245-88.
- [83] F. Yuan, L.D. Quan, L. Cui, S.R. Goldring, and D. Wang, Development of macromolecular prodrug for rheumatoid arthritis. *Adv Drug Deliv Rev* (2012).
- [84] D. Funk, H.H. Schrenk, and E. Frei, Development of a novel polyethylene glycol-corticosteroid-conjugate with an acid-cleavable linker. *J Drug Target* 19 (2011) 434-45.
- [85] C.C. Lee, A.T. Cramer, F.C. Szoka, and J.M. Fréchet, An intramolecular cyclization reaction is responsible for the in vivo inefficacy and apparent pH insensitive hydrolysis kinetics of hydrazone carboxylate derivatives of doxorubicin. *Bioconjug Chem* 17 (2006) 1364-8.
- [86] K. Nishida, K. Mihara, T. Takino, S. Nakane, Y. Takakura, M. Hashida, and H. Sezaki, Hepatic disposition characteristics of electrically charged macromolecules in rat in vivo and in the perfused liver. *Pharm Res* 8 (1991) 437-44.
- [87] T. Fujita, M. Nishikawa, C. Tamaki, Y. Takakura, M. Hashida, and H. Sezaki, Targeted delivery of human recombinant superoxide dismutase by chemical modification with mono- and polysaccharide derivatives. *J Pharmacol Exp Ther* 263 (1992) 971-8.
- [88] Y. TAKAKURA, K. MIHARA, and M. HASHIDA, CONTROL OF THE DISPOSITION PROFILES OF PROTEINS IN THE KIDNEY VIA CHEMICAL MODIFICATION. *Journal of Controlled Release* 28 (1994) 111-119.
- [89] K. Mihara, Y. Oka, K. Sawai, Y. Takakura, and M. Hashida, Improvement of therapeutic effect of human recombinant superoxide dismutase on ischemic acute renal failure in the rat via cationization and conjugation with polyethylene glycol. *J Drug Target* 2 (1994) 317-21.
- [90] M. Nishikawa, H. Hirabayashi, Y. Takakura, and M. Hashida, Design for cell-specific targeting of proteins utilizing sugar-recognition mechanism: effect of molecular weight of proteins on targeting efficiency. *Pharm Res* 12 (1995) 209-14.
- [91] M. Nishikawa, C. Miyazaki, F. Yamashita, Y. Takakura, and M. Hashida, Galactosylated proteins are recognized by the liver according to the surface density of galactose moieties. *Am J Physiol* 268 (1995) G849-56.
- [92] Y. Yabe, Y. Koyama, M. Nishikawa, Y. Takakura, and M. Hashida, Hepatocyte-specific distribution of catalase and its inhibitory effect on hepatic ischemia/reperfusion

- injury in mice. *Free Radic Res* 30 (1999) 265-74.
- [93] Y. Yabe, N. Kobayashi, T. Nishihashi, R. Takahashi, M. Nishikawa, Y. Takakura, and M. Hashida, Prevention of neutrophil-mediated hepatic ischemia/reperfusion injury by superoxide dismutase and catalase derivatives. *J Pharmacol Exp Ther* 298 (2001) 894-9.
- [94] Y. Yabe, N. Kobayashi, M. Nishikawa, K. Mihara, F. Yamashita, Y. Takakura, and M. Hashida, Pharmacokinetics and preventive effects of targeted catalase derivatives on hydrogen peroxide-induced injury in perfused rat liver. *Pharm Res* 19 (2002) 1815-21.
- [95] Y. Higuchi, M. Nishikawa, S. Kawakami, F. Yamashita, and M. Hashida, Uptake characteristics of mannosylated and fucosylated bovine serum albumin in primary cultured rat sinusoidal endothelial cells and Kupffer cells. *Int J Pharm* 287 (2004) 147-54.
- [96] Y. Yamasaki, K. Sumimoto, M. Nishikawa, F. Yamashita, K. Yamaoka, M. Hashida, and Y. Takakura, Pharmacokinetic analysis of in vivo disposition of succinylated proteins targeted to liver nonparenchymal cells via scavenger receptors: importance of molecular size and negative charge density for in vivo recognition by receptors. *J Pharmacol Exp Ther* 301 (2002) 467-77.
- [97] R.W. Jansen, G. Molema, T.L. Ching, R. Oosting, G. Harms, F. Moolenaar, M.J. Hardonk, and D.K. Meijer, Hepatic endocytosis of various types of mannose-terminated albumins. What is important, sugar recognition, net charge, or the combination of these features. *J Biol Chem* 266 (1991) 3343-8.
- [98] H. Li, and Z.M. Qian, Transferrin/transferrin receptor-mediated drug delivery. *Med Res Rev* 22 (2002) 225-50.
- [99] M. Singh, Transferrin As A targeting ligand for liposomes and anticancer drugs. *Curr Pharm Des* 5 (1999) 443-51.
- [100] J. Wu, M.H. Nantz, and M.A. Zern, Targeting hepatocytes for drug and gene delivery: emerging novel approaches and applications. *Front Biosci* 7 (2002) d717-25.
- [101] P.C. Rensen, R.L. de Vreeh, J. Kuiper, M.K. Bijsterbosch, E.A. Biessen, and T.J. van Berkel, Recombinant lipoproteins: lipoprotein-like lipid particles for drug targeting. *Adv Drug Deliv Rev* 47 (2001) 251-76.
- [102] G. Bendas, Immunoliposomes: a promising approach to targeting cancer therapy. *BioDrugs* 15 (2001) 215-24.
- [103] N. Svensen, J.G. Walton, and M. Bradley, Peptides for cell-selective drug delivery. *Trends Pharmacol Sci* 33 (2012) 186-92.
- [104] M. Marradi, I. García, and S. Penadés, Carbohydrate-based nanoparticles for potential

- applications in medicine. *Prog Mol Biol Transl Sci* 104 (2011) 141-73.
- [105] K. Jain, P. Kesharwani, U. Gupta, and N.K. Jain, A review of glycosylated carriers for drug delivery. *Biomaterials* 33 (2012) 4166-86.
- [106] L. Yang, X. Zhang, M. Ye, J. Jiang, R. Yang, T. Fu, Y. Chen, K. Wang, C. Liu, and W. Tan, Aptamer-conjugated nanomaterials and their applications. *Adv Drug Deliv Rev* 63 (2011) 1361-70.
- [107] E. Levy-Nissenbaum, A.F. Radovic-Moreno, A.Z. Wang, R. Langer, and O.C. Farokhzad, Nanotechnology and aptamers: applications in drug delivery. *Trends Biotechnol* 26 (2008) 442-9.
- [108] M.E. Davis, The first targeted delivery of siRNA in humans via a self-assembling, cyclodextrin polymer-based nanoparticle: from concept to clinic. *Mol Pharm* 6 (2009) 659-68.
- [109] K.K. Sankhala, A.C. Mita, R. Adinin, L. Wood, M. Beeram, S. Bullock, N. Yamagata, K. Matsuno, T. Fujisawa, and A. Phan, A phase I pharmacokinetic (PK) study of MBP-426, a novel liposome encapsulated oxaliplatin, 2009, pp. S2535.
- [110] A.E. Nel, L. Mädler, D. Velegol, T. Xia, E.M. Hoek, P. Somasundaran, F. Klaessig, V. Castranova, and M. Thompson, Understanding biophysicochemical interactions at the nano-bio interface. *Nat Mater* 8 (2009) 543-57.
- [111] P. Decuzzi, and M. Ferrari, The role of specific and non-specific interactions in receptor-mediated endocytosis of nanoparticles. *Biomaterials* 28 (2007) 2915-22.
- [112] H. Gao, W. Shi, and L.B. Freund, Mechanics of receptor-mediated endocytosis. *Proc Natl Acad Sci U S A* 102 (2005) 9469-74.
- [113] A. Murao, M. Nishikawa, C. Managit, J. Wong, S. Kawakami, F. Yamashita, and M. Hashida, Targeting efficiency of galactosylated liposomes to hepatocytes in vivo: effect of lipid composition. *Pharm Res* 19 (2002) 1808-14.
- [114] C. Managit, S. Kawakami, F. Yamashita, and M. Hashida, Effect of galactose density on asialoglycoprotein receptor-mediated uptake of galactosylated liposomes. *J Pharm Sci* 94 (2005) 2266-75.
- [115] S. Kawakami, J. Wong, A. Sato, Y. Hattori, F. Yamashita, and M. Hashida, Biodistribution characteristics of mannosylated, fucosylated, and galactosylated liposomes in mice. *Biochim Biophys Acta* 1524 (2000) 258-65.
- [116] K.F. Pirollo, and E.H. Chang, Does a targeting ligand influence nanoparticle tumor localization or uptake? *Trends Biotechnol* 26 (2008) 552-8.
- [117] Y.H. Bae, Drug targeting and tumor heterogeneity. *J Control Release* 133 (2009) 2-3.
- [118] D.B. Kirpotin, D.C. Drummond, Y. Shao, M.R. Shalaby, K. Hong, U.B. Nielsen, J.D. Marks, C.C. Benz, and J.W. Park, Antibody targeting of long-circulating lipidic

- nanoparticles does not increase tumor localization but does increase internalization in animal models. *Cancer Res* 66 (2006) 6732-40.
- [119] Y. Bae, N. Nishiyama, and K. Kataoka, In vivo antitumor activity of the folate-conjugated pH-sensitive polymeric micelle selectively releasing adriamycin in the intracellular acidic compartments. *Bioconjug Chem* 18 (2007) 1131-9.
- [120] O. Trédan, C.M. Galmarini, K. Patel, and I.F. Tannock, Drug resistance and the solid tumor microenvironment. *J Natl Cancer Inst* 99 (2007) 1441-54.
- [121] K. Kawabata, Y. Takakura, and M. Hashida, The fate of plasmid DNA after intravenous injection in mice: involvement of scavenger receptors in its hepatic uptake. *Pharm Res* 12 (1995) 825-30.
- [122] E.M. Renkin, Filtration, diffusion, and molecular sieving through porous cellulose membranes. *J Gen Physiol* 38 (1954) 225-43.

Figure Captions

Figure 1. Hepatic uptake and urinary excretion clearances of macromolecules in mice following intravenous injection. Dex10, dextran (10kDa); Dex70, dextran (70kDa); CMDex, carboxymethyl Dex70; DEAEDex, diethylaminoethyl Dex70; IgG, immunoglobulin G; BSA, bovine serum albumin; catBSA, cationized BSA; sucBSA, succinylated BSA; SOD, superoxide dismutase; CMDexSOD, CMDex-SOD conjugate; DEAEDexSOD, DEAEDex-SOD conjugate; pCAT, plasmid DNA encoding chloramphenicol acetyltransferase; T₁₀, thymidine decamer. The original data were collected from the literatures [61; 87; 121].

Figure 2. Restricted penetration through porous membranes. The ordinate (A/A_0) indicates relative effective area for penetration in porous membranes. The solid and broken lines assume the pore radius of 50 nm and 300 nm, respectively. As the solute radius increases, steric hindrance becomes larger. The theoretical curves are obtained using the Renkin equation [122]:

$$\frac{A}{A_0} = \left(1 - \frac{a}{r}\right)^2 \left[1 - 2.104 \cdot \left(\frac{a}{r}\right) + 2.09 \cdot \left(\frac{a}{r}\right)^3 - 0.95 \cdot \left(\frac{a}{r}\right)^5 \right]$$

where a and r are the solute radius and the pore radius, respectively.

Figure 3. Process of movement from systemic circulation to cell interior. Extraction ratio is proportion of single-pass extraction at the steady state, which can be calculated from difference between inlet and outlet concentrations. Q , P , and U represent blood flow, endothelial permeability, and intrinsic uptake clearance, respectively.

Figure 1

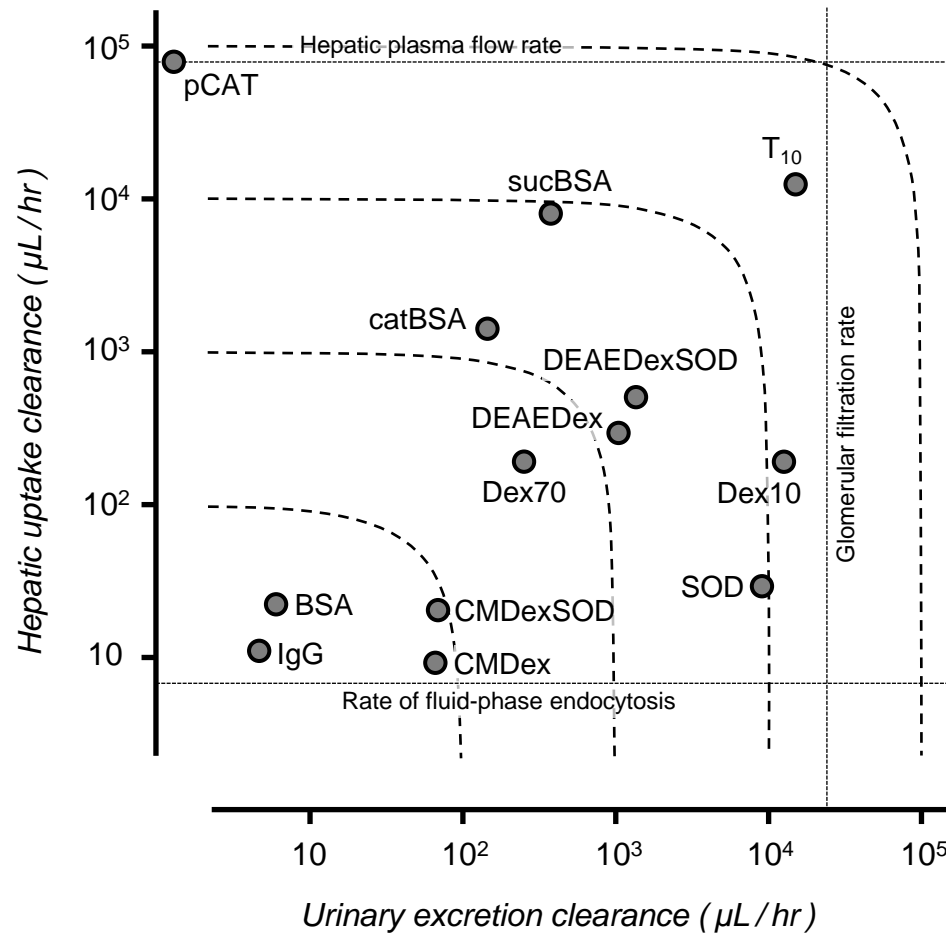

Figure 2

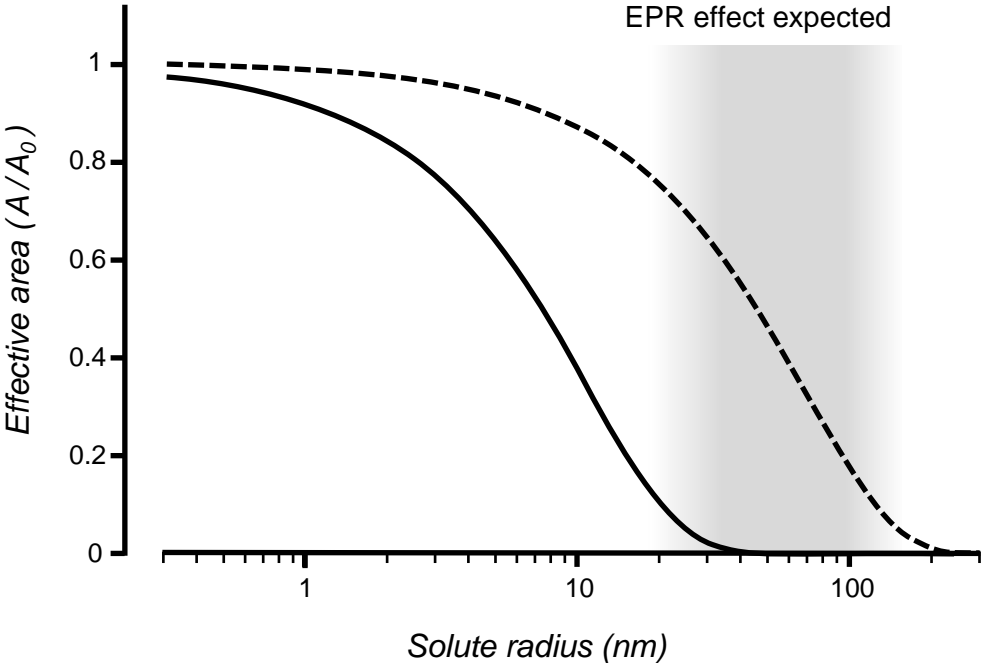
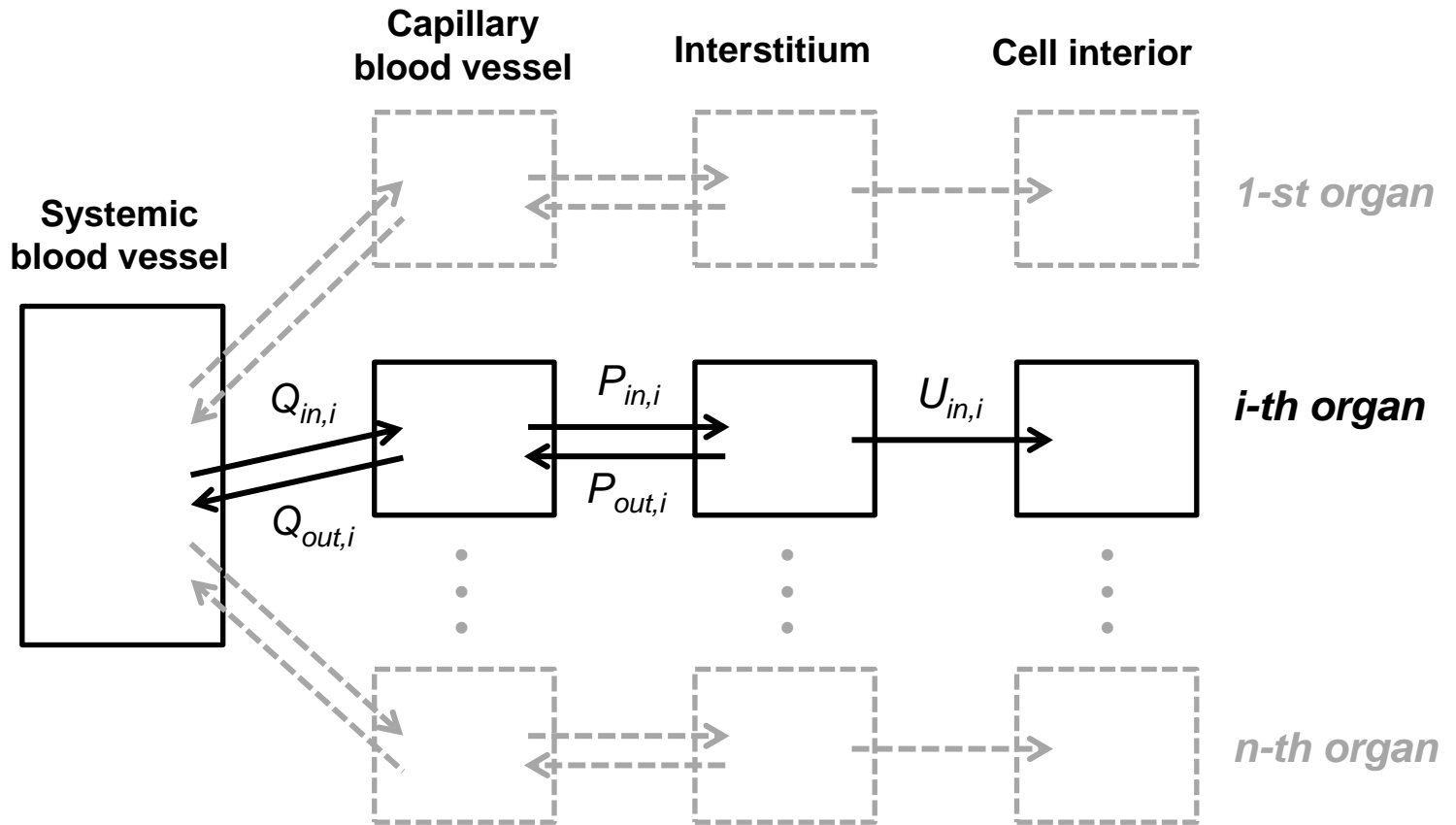

Figure 3



$$\text{Extraction Ratio}(E_i) = \frac{1}{1 + \frac{Q_{out,i}}{P_{in,i}} \cdot \left(1 + \frac{P_{out,i}}{U_{in,i}} \right)}$$