

Title	A new formulation of laser step diagonal measurement—Three-dimensional case
Author(s)	Ibaraki, Soichi; Hata, Takafumi
Citation	Precision Engineering (2010), 34(3): 516-525
Issue Date	2010-07
URL	http://hdl.handle.net/2433/113249
Right	
Type	Journal Article
Textversion	author

A New Formulation of Laser Step Diagonal Measurement – Three-dimensional Case–

Soichi Ibaraki*and Takafumi Hata

Department of Micro Engineering, Kyoto University
Yoshida-honmachi, Sakyo-ku, Kyoto, 606-8501, Japan

Abstract

To ensure the motion accuracy of a machine tool over its entire three-dimensional workspace, it is important to evaluate all the volumetric errors associated with three linear axes including three linear displacement errors, six straightness errors and three squareness errors. The laser step diagonal measurement modifies the diagonal displacement measurement, described in the standard ISO 230-6, by executing a diagonal as a sequence of single-axis motions. It has been claimed that the step diagonal test enables the identification of all the volumetric error components by using a linear laser interferometer only. This paper first shows that the conventional formulation of step diagonal measurements is potentially subject to a significant estimation error caused by setup errors in mirror and laser directions. We then propose a new formulation of laser step diagonal measurement, in order to accurately identify three-dimensional volumetric errors even under the existence of setup errors. The effectiveness of the modified identification scheme is experimentally investigated by an application example of three-dimensional laser step diagonal measurements to a high-precision vertical machining center.

Key Words: Step diagonal measurement, volumetric accuracy, laser interferometer, machine tools, measurement.

*Corresponding author: Address: Department of Micro Engineering, Kyoto University, Yoshida-honmachi, Sakyo-ku, Kyoto, 606-8501, Japan; phone: +81-75-753-5227; fax: +81-75-753-5227; e-mail:ibaraki@prec.kyoto-u.ac.jp

1 Introduction

In ISO standards(e.g. ISO 230-1 [1]), the motion accuracy of a feed drive of a machine tool is basically evaluated in the axis-to-axis basis; the linear positioning error and straightness errors are separately measured for each axis, and the squareness error between two axes is then measured. Error measurements for a coordinate measuring machine (CMM) described in ISO 10360 series contain tests with a different concept. By using an artefact such as a ball plate, all the three-dimensional position error components (in X, Y, and Z) for the given reference location are directly measured over the entire workspace. The importance of the evaluation of such volumetric errors has been recently recognized also by many machine tool builders [2]. Currently, technical committees in ASME (TC52) and ISO (TC39) are working on the standardization of the definition of volumetric accuracy for machine tools [3].

In accuracy measurement of machine tools, linear positioning errors are typically measured by using a laser interferometer. Straightness and squareness errors are often measured by using a high-precision displacement sensor and an artifact such as a straight edge or a square edge. Naturally, the artifact must have geometric and dimensional accuracies guaranteed to be higher than the accuracy of the measured machine. Furthermore, since the measurement is one-dimensional, an operator must change the setup of a sensor and an artifact every time for the measurement of each different error component. For orthogonal three-axis machines, 3 linear displacement errors, 6 straightness errors and 3 squareness errors must be measured by different setups. Dual-beam laser systems or autocollimators to measure straightness and squareness errors are also available from many companies. They do not require an artifact such as a straight edge, but it is the same in that a different setup

is needed to measure each different error component.

For quicker, lower-cost evaluation of volumetric errors of a machine tool, the standards ASME B5.54 [4] and ISO230-6 [5] define the diagonal measurement by using a laser interferometer. As is illustrated in Fig. 1, the machine moves along each body diagonal of the machine's workspace, and the diagonal displacement is measured by using a laser interferometer. Chapman [6] discussed in details that it is not possible to use the diagonal measurement to identify each volumetric error component, although it can be used for a quick check of squareness errors. It is not possible to distinguish linear errors, straightness errors, and squareness errors of each axis from the results of diagonal tests.

As an extension of diagonal measurement, the step diagonal measurement, or the vector measurement, has been proposed by Wang [7, 8]. The step diagonal measurement modifies the diagonal measurement by executing a diagonal as a sequence of single-axis motions. Figure 2 illustrates the three-dimensional (3D) step diagonal measurement. Unlike the diagonal measurement, Wang claimed that total three step diagonal measurements for different diagonals can separately identify all volumetric errors, including 3 linear displacement errors, 6 straightness errors and 3 squareness errors. Compared to conventional measurements using a straight edge and a square edge, it is thus significantly more time-efficient. Since it does not require an artefact, it is lower cost, especially for a large-sized machine, where large artefacts of high geometric accuracy are needed.

Chapman [6] also discussed an issue with the step diagonal test. He showed that the misalignment of mirror direction, as well as the machine's angular motion errors, may causes a significant error in identified volumetric errors. In our previous publication [9], we further extended this discussion to show that the conventional formulation by Wang [7] is valid only

when implicit assumptions related to laser and mirror setups are met, and that it is generally not possible to guarantee these conditions when volumetric errors of the machine are unknown.

Then, for the two-dimensional (2D) version of step diagonal measurement, we [9] proposed its new formulation such that all volumetric errors can be identified even when significant setup errors exist. We showed that linear positioning errors must be independently measured, and then normal error components (straightness and squareness errors) can be identified by using the proposed formulation.

Another potentially critical error factor for step diagonal measurements is angular errors of each axis (i.e. yaw, pitch and roll). Soons [10] formulated their effect on the 3D step diagonal measurement and clarified that they may cause a significant identification error. He also suggested an interesting formulation to separately identify angular errors from step diagonal tests. However, he only presented its mathematical formulation, without discussing its validity in practical industrial environment.

The main objective of this paper is to extend our discussion in [9] to the 3D version of laser step diagonal measurement. Major contributions of this paper, other than those previously presented in [9], are summarized as follows: 1) A new formulation of 3D laser step diagonal measurement is presented. The extension from 2D to 3D cases is not obvious, as will be discussed in Remark #1 in Section 3.2. 2) The feasibility of the cancellation of the machine's angular errors in step diagonal measurements is studied with considering measurement uncertainties of laser measurement. 3) An experimental validation of step diagonal measurement is presented. Since Wang's first publication[7], to our knowledge, there has been few publication that experimentally demonstrated its estimation accuracy by com-

paring the estimates to conventional, more reliable measurements. The experimental studies presented in this paper will be essential to promote its practical application to the industry.

2 Review: Conventional Formulation of Laser Step Diagonal Measurement and Its Inherent Issues

This section briefly reviews the conventional formulation of the identification of volumetric errors by step diagonal measurements presented by Wang [7], and then its inherent issues discussed in our previous publication [9].

Figure 3 illustrates the setup of the 3D step diagonal measurement. For the simplicity of drawing, only single block is depicted. Define $\Delta e_x(x(k))$, $\Delta e_y(x(k))$ and $\Delta e_z(x(k))$ as the positioning error in X-, Y-, and Z-directions, respectively, when the machine moves toward the X-direction from the reference position $x(k-1)$ to $x(k)$ ($k = 1, \dots, N$). In other words, when the machine moves from the point A to B in Fig. 3, the vector representing its actual motion is given by $\left[a_x + \Delta e_x(x(k)) \quad \Delta e_y(x(k)) \quad \Delta e_z(x(k)) \right]^T$. $\Delta e_x(y(k))$, $\Delta e_z(y(k))$, $\Delta e_x(z(k))$, $\Delta e_y(z(k))$, and $\Delta e_z(z(k))$ are defined similarly. The subscript of $\Delta e_*(*)$ represents the error direction, and the symbol in parentheses represents the direction of motion. In this paper, these total $9N$ error components are collectively called volumetric errors.

The nominal size of each block is given by $a_x \times a_y \times a_z$ (in X×Y×Z), as shown in Fig. 2 (i.e. $x(k) = x(k-1) + a_x$, $y(k) = y(k-1) + a_y$, and $z(k) = z(k-1) + a_z$ in Fig. 3). When the laser is aligned to the body diagonal AG in Fig. 3, the diagonal displacement with the motion toward X, Y, and Z directions in the k -th block are respectively given by $R_{x,ppp}(k)$,

$R_{y,ppp}(k)$, and $R_{z,ppp}(k)$. This laser beam setup is referred to as ppp measurement hereafter. Note that “p” stands for “positive,” and “ppp” indicates that all of x, y and z components of the laser beam direction vector are positive. The subscript of $R_{*,*}(k)$ represents the direction of motion (x, y, z) and the laser direction. A similar measurement is done as the laser is aligned along body diagonals BH and DF. They are respectively referred to as npp and pnp measurements (“n” stands for “negative”). $R_{x,npp}(k)$, $R_{y,npp}(k)$, $R_{z,npp}(k)$, $R_{x,pnp}(k)$, $R_{y,pnp}(k)$, and $R_{z,pnp}(k)$ are defined similarly.

For example, $R_{x,ppp}(k)$ is given by:

$$R_{x,ppp}(k) = \begin{bmatrix} l_{x,ppp} & l_{y,ppp} & l_{z,ppp} \end{bmatrix} \cdot \begin{bmatrix} a_x + \Delta e_x(x(k)) \\ \Delta e_y(x(k)) \\ \Delta e_z(x(k)) \end{bmatrix} \quad (1)$$

where $k = 1, \dots, N$. $(l_{x,ppp}, l_{y,ppp}, l_{z,ppp})$ is the unit vector representing the laser direction in the ppp measurement. $(l_{x,npp}, l_{y,npp}, l_{z,npp})$ and $(l_{x,pnp}, l_{y,pnp}, l_{z,pnp})$ are defined analogously.

By combining similar formulations for other diagonal displacements, we have [7]:

$$\begin{bmatrix} l_{x,ppp} & l_{y,ppp} & l_{z,ppp} & 0 & 0 & 0 & 0 & 0 & 0 \\ 0 & 0 & 0 & l_{x,ppp} & l_{y,ppp} & l_{z,ppp} & 0 & 0 & 0 \\ 0 & 0 & 0 & 0 & 0 & 0 & l_{x,ppp} & l_{y,ppp} & l_{z,ppp} \\ -l_{x,npp} & -l_{y,npp} & -l_{z,npp} & 0 & 0 & 0 & 0 & 0 & 0 \\ 0 & 0 & 0 & l_{x,npp} & l_{y,npp} & l_{z,npp} & 0 & 0 & 0 \\ 0 & 0 & 0 & 0 & 0 & 0 & l_{x,npp} & l_{y,npp} & l_{z,npp} \\ l_{x,pnp} & l_{y,pnp} & l_{z,pnp} & 0 & 0 & 0 & 0 & 0 & 0 \\ 0 & 0 & 0 & -l_{x,pnp} & -l_{y,pnp} & -l_{z,pnp} & 0 & 0 & 0 \\ 0 & 0 & 0 & 0 & 0 & 0 & l_{x,pnp} & l_{y,pnp} & l_{z,pnp} \end{bmatrix} \begin{bmatrix} a + \Delta e_x(x(k)) \\ \Delta e_y(x(k)) \\ \Delta e_z(x(k)) \\ \Delta e_x(y(k)) \\ a + \Delta e_y(y(k)) \\ \Delta e_z(y(k)) \\ \Delta e_x(z(k)) \\ \Delta e_y(z(k)) \\ a + \Delta e_z(z(k)) \end{bmatrix} = \begin{bmatrix} R_{x,ppp}(k) \\ R_{y,ppp}(k) \\ R_{z,ppp}(k) \\ R_{x,npp}(N - k + 1) \\ R_{y,npp}(k) \\ R_{z,npp}(k) \\ R_{x,pnp}(k) \\ R_{y,pnp}(N - k + 1) \\ R_{z,pnp}(k) \end{bmatrix} \quad (2)$$

Assume their nominal laser directions, i.e.:

$$\begin{aligned} \begin{bmatrix} l_{x,ppp} & l_{y,ppp} & l_{z,ppp} \end{bmatrix} &= \frac{1}{\|a\|} \begin{bmatrix} a_x & a_y & a_z \end{bmatrix} \\ \begin{bmatrix} l_{x,npp} & l_{y,npp} & l_{z,npp} \end{bmatrix} &= \frac{1}{\|a\|} \begin{bmatrix} -a_x & a_y & a_z \end{bmatrix} \\ \begin{bmatrix} l_{x,pnp} & l_{y,pnp} & l_{z,pnp} \end{bmatrix} &= \frac{1}{\|a\|} \begin{bmatrix} a_x & -a_y & a_z \end{bmatrix} \end{aligned} \quad (3)$$

where $\|a\| := \sqrt{a_x^2 + a_y^2 + a_z^2}$. Then, all the volumetric errors, $\Delta e_x(x), \dots, \Delta e_z(z)$ can be estimated by solving Eq. (2).

Our previous paper [9] has discussed inherent issues with this conventional formulation. Notice that the conventional formulation is valid only when the following conditions are satisfied: 1) laser beam directions are precisely aligned to nominal directions, and 2) the flat mirror is precisely aligned perpendicular to the laser beam, and 3) the machine's angular errors are sufficiently small. In practical setup of step diagonal measurement, the direction of the laser beam and the flat mirror can be only aligned based on the motion of the machine to be measured. In such a case, it is generally not possible to guarantee the satisfaction of 1) and 2), when volumetric errors of the machine are unknown. Therefore, volumetric errors identified by the conventional formulation generally contain a potentially significant identification error. This discussion applies to the 3D case (2) as well.

3 New Formulation of 3D Laser Step Diagonal Measurement

3.1 Sensitivity of Setup Errors in Conventional Formulation

To propose a new formulation of laser step diagonal measurement such that setup errors do not impose any effect on estimated volumetric errors, this section first formulates the sensitivity of setup errors on the estimates of volumetric errors in the conventional formulation (2). The misalignment errors of laser and mirror directions are collectively referred to as setup errors hereafter. To simplify the discussion, this section assumes that the machine's angular error is negligibly small. The influence of angular errors will be discussed later in Section 3.3.

In the k -th block, suppose that the “nominal” diagonal distance for the x-motion is denoted by $\tilde{R}_{x,ppp}(k)$, when the laser direction is perfectly aligned to the nominal direction and the mirror is aligned perfectly perpendicular to the laser direction. The symbol $\tilde{}$ indicates the nominal distance without setup errors. As has been discussed in [9], the misalignment of laser and mirror directions gives a constant error to the diagonal displacement at each block. Suppose that this misalignment error in ppp measurement is given by $\delta R_{x,ppp}$. In other words,

$$R_{x,ppp}(k) = \tilde{R}_{x,ppp}(k) + \delta R_{x,ppp} \quad (4)$$

Under the assumption that the machine’s angular error is negligibly small, we can approximate that the effect of setup errors, $\delta R_{x,ppp}$, is the same for all the blocks. Other parameters, $\delta R_{y,ppp}$, $\delta R_{z,ppp}$, $\delta R_{x,npp}$, $\delta R_{y,npp}$, $\delta R_{z,npp}$, $\delta R_{x,pnp}$, $\delta R_{y,pnp}$, $\delta R_{z,pnp}$, are defined analogously. Notice that we have:

$$\delta R_{x,ppp} + \delta R_{y,ppp} + \delta R_{z,ppp} \approx 0 \quad (5)$$

which applies also to npp and pnp measurements. By solving Eq.(2), we have:

$$\Delta \hat{e}_x(x(k)) = \frac{\|a\|}{2a_x} \{R_{x,ppp}(k) + R_{x,npp}(N - k + 1) - (\delta R_{x,ppp} + \delta R_{x,npp})\} - a_x \quad (6)$$

$$\Delta \hat{e}_y(x(k)) = \frac{\|a\|}{2a_y} \{R_{x,ppp}(k) - R_{x,pnp}(k) - (\delta R_{x,ppp} - \delta R_{x,pnp})\} \quad (7)$$

$$\Delta \hat{e}_z(x(k)) = \frac{\|a\|}{2a_z} \{R_{x,pnp}(k) - R_{x,npp}(N - k + 1) - (\delta R_{x,pnp} - \delta R_{x,npp})\} \quad (8)$$

$$\Delta \hat{e}_x(y(k)) = \frac{\|a\|}{2a_x} \{R_{y,ppp}(k) - R_{y,npp}(k) - (\delta R_{y,ppp} - \delta R_{y,npp})\} \quad (9)$$

$$\Delta \hat{e}_y(y(k)) = \frac{\|a\|}{2a_y} \{R_{y,ppp}(k) + R_{y,pnp}(N - k + 1) - (\delta R_{y,ppp} + \delta R_{y,pnp})\} - a_y \quad (10)$$

$$\Delta \hat{e}_z(y(k)) = \frac{\|a\|}{2a_z} \{R_{y,npp}(k) - R_{y,pnp}(N - k + 1) - (\delta R_{y,npp} - \delta R_{y,pnp})\} \quad (11)$$

$$\Delta \hat{e}_x(z(k)) = \frac{\|a\|}{2a_x} \{R_{z,ppp}(k) - R_{z,npp}(k) - (\delta R_{z,ppp} - \delta R_{z,npp})\} \quad (12)$$

$$\Delta \hat{e}_y(z(k)) = \frac{\|a\|}{2a_y} \{R_{z,ppp}(k) - R_{z,pnp}(k) - (\delta R_{z,ppp} - \delta R_{z,pnp})\} \quad (13)$$

$$\Delta \hat{e}_z(z(k)) = \frac{\|a\|}{2a_z} \{R_{z,npp}(k) + R_{z,pnp}(k) - (\delta R_{z,npp} + \delta R_{z,pnp})\} - a_z \quad (14)$$

Note that the symbol $\hat{\cdot}$ represents the estimate under setup errors. Equations (6)~(14) indicate that the estimated volumetric errors are subject to the influence of setup errors by a factor of $\frac{\|a\|}{2a_x}$. In practical setups, it is generally not valid to assume that they are negligibly small. Furthermore, it can be easily observed that it is not possible to identify nine setup errors, $\delta R_{x,ppp}, \dots, \delta R_{z,pnp}$ from three step diagonal measurements only.

3.2 New Formulation to Identify Volumetric Errors under Setup Errors

In order to cancel setup errors, we propose to directly measure linear error components, $\Delta e_x(x(k))$, $\Delta e_y(y(k))$ and $\Delta e_z(z(k))$ ($k = 1, \dots, N$). First, for the simplicity of notation, define:

$$\begin{aligned}
\lambda_{xx} &:= \delta R_{x,ppp} + \delta R_{x,npp}, & \lambda_{yx} &:= \delta R_{x,ppp} - \delta R_{x,pnp}, \\
\lambda_{zx} &:= \delta R_{x,pnp} - \delta R_{x,npp}, & \lambda_{xy} &:= \delta R_{y,ppp} - \delta R_{y,npp}, \\
\lambda_{yy} &:= \delta R_{y,ppp} + \delta R_{y,pnp}, & \lambda_{zy} &:= \delta R_{y,npp} - \delta R_{y,pnp}, \\
\lambda_{xz} &:= \delta R_{z,ppp} - \delta R_{z,npp}, & \lambda_{yz} &:= \delta R_{z,ppp} - \delta R_{z,pnp}, \\
\lambda_{zz} &:= \delta R_{z,npp} + \delta R_{z,pnp}
\end{aligned} \tag{15}$$

which represent the effect of setup errors in Eqs. (6)~(14), respectively. For example, λ_{xx} represents the setup error term in the formulation of $\Delta \hat{e}_x(x(k))$ (Eq. (6)). The subscript of each symbol indicates the volumetric error that contains it. Then, when linear positioning errors, $\Delta e_x(x(k))$, $\Delta e_y(y(k))$, $\Delta e_z(z(k))$ ($k = 1, \dots, N$), are given, from Eqs. (6), (10), and (14), λ_{xx} , λ_{yy} , and λ_{zz} can be respectively estimated as follows:

$$\begin{aligned}
\hat{\lambda}_{xx} &:= \text{mean} \left\{ -\frac{2a_x}{\|a\|} (\Delta e_x(x(k)) + a_x) + (R_{x,ppp}(k) + R_{x,npp}(N - k + 1)) \right\} \\
\hat{\lambda}_{yy} &:= \text{mean} \left\{ -\frac{2a_y}{\|a\|} (\Delta e_y(y(k)) + a_y) + (R_{y,ppp}(k) + R_{y,pnp}(N - k + 1)) \right\} \\
\hat{\lambda}_{zz} &:= \text{mean} \left\{ -\frac{2a_z}{\|a\|} (\Delta e_z(z(k)) + a_z) + (R_{z,npp}(k) + R_{z,pnp}(k)) \right\}
\end{aligned} \tag{16}$$

where the function “mean” represents the mean value over $k = 1, \dots, N$. Notice that the orientation of the coordinate system can be arbitrarily set. For example, the coordinate system can be defined such that:

$$\text{mean} \{ \Delta e_y(x(k)) \} = \text{mean} \{ \Delta e_z(x(k)) \} = \text{mean} \{ \Delta e_y(z(k)) \} = 0 \tag{17}$$

Under this assumption, λ_{yx} , λ_{zx} , and λ_{yz} , can be estimated from Eqs. (7)(8)(13) as follows:

$$\begin{aligned}
\hat{\lambda}_{yx} &:= \text{mean} \left\{ -\frac{2a_y}{\|a\|} \Delta \hat{e}_y(x(k)) + (R_{x,ppp}(k) - R_{x,pnp}(k)) \right\} \\
\hat{\lambda}_{zx} &:= \text{mean} \left\{ -\frac{2a_z}{\|a\|} \Delta \hat{e}_z(x(k)) + (R_{x,pnp}(k) - R_{x,npp}(N - k + 1)) \right\} \\
\hat{\lambda}_{yz} &:= \text{mean} \left\{ -\frac{2a_y}{\|a\|} \Delta \hat{e}_y(z(k)) + (R_{z,ppp}(k) - R_{z,pnp}(k)) \right\}
\end{aligned} \tag{18}$$

Now, from the definitions (15) and Eq. (5), we have:

$$\begin{aligned}
\hat{\lambda}_{xy} &= -\hat{\lambda}_{yx} - \hat{\lambda}_{zx} - \hat{\lambda}_{xz} \\
\hat{\lambda}_{zy} &= -\hat{\lambda}_{yx} - \hat{\lambda}_{yz} - \hat{\lambda}_{xy} \\
\hat{\lambda}_{xz} &= -\hat{\lambda}_{zx} - \hat{\lambda}_{xx} - \hat{\lambda}_{yy} - \hat{\lambda}_{zz}
\end{aligned} \tag{19}$$

From Eqs. (16)(18)(19), we can identify all of nine parameters in Eq. (15). $6N$ volumetric errors, $\Delta\hat{e}_y(x(k)) \sim \Delta\hat{e}_y(z(k))$, can be then identified by Eqs. (6)~(14).

Remark #1:

In the 2D case discussed in [9], setup errors only affect the estimates of linear error components, $\hat{e}_x(x(k))$ and $\hat{e}_y(y(k))$. In other words, when $\hat{e}_x(x(k))$ and $\hat{e}_y(y(k))$ are replaced with measured values, the conventional formulation (2D version of Eq. (2)) gives good estimates for normal error components, $\hat{e}_y(x(k))$ and $\hat{e}_x(y(k))$ ($k = 1, \dots, N$). This is not the case with the three-dimensional case. As has been discussed above, the conventional formulation (2) may give a significant estimation error for normal error components, even when linear error components are directly measured and excluded from the estimation.

Remark #2:

Both conventional and proposed formulations of step diagonal measurement assume that the machine's volumetric errors are precisely repeatable. Clearly, the machine's unrepeatable errors cause an estimation error. Laser measurement uncertainties in total 6 measurements also deteriorate the estimation accuracy. Although it is not possible to assure the estimation uncertainty lower than the accumulated positioning uncertainties and measurement uncer-

tainties, we claim that a significant practical value of step diagonal measurement is in that it can evaluate straightness and squareness errors by using a linear laser interferometer only. Compared to the conventional artifact-based measurement, it requires lower cost, applying a laser interferometer to the evaluation of all the errors, without using a artifact of high geometric accuracy. It is particularly advantageous for a large-sized machine.

Remark #3:

When linear error components, $\Delta e_x(x(k))$, $\Delta e_y(y(k))$ and $\Delta e_z(z(k))$, are known, Eq. (2) can be reformulated as follows:

$$\begin{aligned}
& \begin{bmatrix} l_{y,ppp} & l_{z,ppp} & l_{x,ppp} & l_{z,ppp} & l_{x,ppp} & l_{y,ppp} \\ -l_{y,npp} & -l_{z,npp} & l_{x,npp} & l_{z,npp} & l_{x,npp} & l_{y,npp} \\ l_{y,pnp} & l_{z,pnp} & -l_{x,pnp} & -l_{z,pnp} & l_{x,pnp} & l_{y,pnp} \\ l_{y,pnp} & l_{z,pnp} & 0 & 0 & 0 & 0 \\ 0 & 0 & l_{x,ppp} & l_{z,ppp} & 0 & 0 \\ 0 & 0 & 0 & 0 & l_{x,ppp} & l_{y,ppp} \end{bmatrix} \begin{bmatrix} \Delta e_y(x(k)) \\ \Delta e_z(x(k)) \\ \Delta e_x(y(k)) \\ \Delta e_z(y(k)) \\ \Delta e_x(z(k)) \\ \Delta e_y(z(k)) \end{bmatrix} \\
& = \begin{bmatrix} (R_{x,ppp}(k) + R_{y,ppp}(k) + R_{z,ppp}(k)) - (a_x + a_y + a_z) - (\Delta e_x(x(k)) + \Delta e_y(y(k)) + \Delta e_z(z(k))) \\ (R_{x,npp}(N - k + 1) + R_{y,npp}(k) + R_{z,npp}(k)) - (a_x + a_y + a_z) - (\Delta e_x(x(k)) + \Delta e_y(y(k)) + \Delta e_z(z(k))) \\ (R_{x,pnp}(k) + R_{y,pnp}(N - k + 1) + R_{z,pnp}(k)) - (a_x + a_y + a_z) - (\Delta e_x(x(k)) + \Delta e_y(y(k)) + \Delta e_z(z(k))) \\ R_{x,pnp}(k) - a_x - \Delta e_x(x(k)) \\ R_{y,ppp}(k) - a_y - \Delta e_y(y(k)) \\ R_{z,ppp}(k) - a_z - \Delta e_z(z(k)) \end{bmatrix} \quad (20)
\end{aligned}$$

By solving Eq. (20), for example, $\Delta e_y(x(k))$ and $\Delta e_z(x(k))$ can be respectively given as follows with the consideration of setup errors represented as in Eq. (4):

$$\begin{aligned}
\Delta \hat{e}_y(x(k)) &= \frac{\|a\|}{2a_y} (R_{x,ppp}(k) - R_{x,pnp}(k)) - \frac{\|a\|}{2a_y} (\delta R_{x,pnp} + \delta R_{y,ppp} + \delta R_{z,ppp}) \\
\Delta \hat{e}_x(y(k)) &= \frac{\|a\|}{2a_x} \{-R_{x,ppp}(k) - (R_{x,npp}(N - k + 1) + R_{y,npp}(k) + R_{z,npp}(k)) - (R_{y,pnp}(N - k + 1) + R_{z,pnp}(k))\} \\
&\quad + \frac{\|a\|}{a_x} (a_x + a_y + a_z) + \{\Delta e_x(x(k)) + \Delta e_y(y(k)) + \Delta e_z(z(k))\} + \frac{\|a\|}{2a_x} (\delta R_{x,pnp} + \delta R_{y,ppp} + \delta R_{z,ppp}) \quad (21)
\end{aligned}$$

where nominal laser beam directions (4) are assumed. Under the assumption in Eq. (17), the effect of setup errors on the first equation is given by:

$$\delta \hat{R}_{x,pnp} + \delta \hat{R}_{y,ppp} + \delta \hat{R}_{z,ppp} = \text{mean} \left\{ -\frac{2a_y}{\|a\|} \Delta \hat{e}_y(x(k)) + (R_{x,ppp}(k) - R_{x,pnp}(k)) \right\} \quad (22)$$

which can remove the effect of setup errors on the estimate of $\Delta \hat{e}_x(y(k))$ given by the second equation in Eq. (21). Analogous relationship can be observed for $\Delta \hat{e}_z(x(k))$ and $\Delta \hat{e}_x(z(k))$,

$\Delta\hat{e}_z(y(k))$ and $\Delta\hat{e}_y(z(k))$. Therefore, by simply solving Eq. (20), one can estimate $6N$ volumetric errors, $\Delta\hat{e}_y(x(k)) \sim \Delta\hat{e}_y(z(k))$, removing the influence of setup errors. This is an alternative formulation of the proposed estimation scheme presented in this subsection.

3.3 Cancellation of the Effect of Angular Errors

The straightness error of a feed drive caused by the deformation of guideways is often accompanied with angular errors (yaw, pitch, and roll) [11]. The formulation (2) ignores the influence of angular errors. When angular errors are not negligibly small compared to position errors, they may cause significant estimation errors. Soons [10] formulates the effect of angular errors on the 3D step diagonal measurement (it is partially presented also by Yang et al. [12]). Soons also presented a formulation to identify angular error from step diagonal measurements. This section first briefly reviews Soons' formulation. The contribution of this paper is on the discussion of the feasibility of this scheme with the consideration of practical measurement uncertainties of laser measurement, which will be presented in Section 4.2.

This section assumes the machine configuration depicted in Fig. 4 (the experimental machine presented in Section 4 has the same configuration). Define the position errors with respect to the reference position $x(k)$ in X-, Y-, and Z-directions by $e_x(x(k)) := \sum_{i=1}^k \Delta e_x(x(i))$, $e_y(x(k)) := \sum_{i=1}^k \Delta e_y(x(i))$, and $e_z(x(k)) := \sum_{i=1}^k \Delta e_z(x(i))$. $e_*(y(k))$, $e_*(z(k))$ are defined analogously ($* = x, y, z$). The angular errors around X-, Y- and Z-axes at the reference position $x(k)$ are defined by $\epsilon_x(x(k))$, $\epsilon_y(x(k))$, and $\epsilon_z(x(k))$, respectively. $\epsilon_*(y(k))$ and $\epsilon_*(z(k))$ are defined analogously ($* = x, y, z$).

Including the influence of angular errors, the position error in X, Y, and Z directions for

the reference position $(x(k), y(k), z(k))$ can be respectively given as follows [10, 12]:

$$\begin{aligned}
e_x(x(k), y(k), z(k)) &= e_x(x(k)) + e_x(y(k)) + e_x(z(k)) + z(k) \cdot \epsilon_y(x(k)) + z(k) \cdot \epsilon_y(y(k)) \\
e_y(x(k), y(k), z(k)) &= e_y(x(k)) + e_y(y(k)) + e_y(z(k)) + x(k) \cdot \epsilon_z(y(k)) - z(k) \cdot \epsilon_x(y(k)) \\
&\quad - z(k) \cdot \epsilon_x(x(k)) \\
e_z(x(k), y(k), z(k)) &= e_z(x(k)) + e_z(y(k)) + e_z(z(k)) - x(k) \cdot \epsilon_y(y(k))
\end{aligned} \tag{23}$$

Angular errors also change the relative direction of the mirror to the laser beam direction. For example, as shown in Fig. 5, suppose that the diagonal displacement in the pnp measurement (i.e. the laser beam is aligned to the diagonal DF) when the mirror moves from the point D to A is represented by $R_{DA,pnp}(k)$. Similarly, the diagonal displacement with the motion from C to B is represented by $R_{CB,pnp}(k)$. Considering all the effects of angular errors, we have:

$$R_{DA,pnp}(k) - R_{CB,pnp}(k) = -a_x \cdot \frac{a_z}{\|a\|} \cdot \Delta\epsilon_x(x(k)) + a_x \cdot \frac{a_x}{\|a\|} \cdot \Delta\epsilon_z(x(k)) \tag{24}$$

It contains angular errors only, with no influence of positioning errors. Similarly, we have:

$$R_{HG,pnp}(k) - R_{DC,pnp}(k) = a_y \cdot \frac{a_z}{\|a\|} \cdot \Delta\epsilon_y(z(k)) + a_y \cdot \frac{a_y}{\|a\|} \cdot \Delta\epsilon_z(x(k)) \tag{25}$$

$$R_{AD,npp}(N-k) - R_{BC,npp}(N-k) = a_y \cdot \frac{a_z}{\|a\|} \cdot \Delta\epsilon_x(x(k)) + a_y \cdot \frac{a_x}{\|a\|} \cdot \Delta\epsilon_z(x(k)) \tag{26}$$

$$R_{EH,npp}(k) - R_{AD,npp}(k) = -a_y \cdot \frac{a_z}{\|a\|} \cdot \Delta\epsilon_x(z(k)) - a_y \cdot \frac{a_y}{\|a\|} \cdot \Delta\epsilon_z(z(k)) \tag{27}$$

$$R_{FE,npp}(k) - R_{BA,npp}(k) = -a_y \cdot \frac{a_z}{\|a\|} \cdot \Delta\epsilon_y(x(k)) + a_y \cdot \frac{a_y}{\|a\|} \cdot \Delta\epsilon_z(z(k)) \tag{28}$$

By solving these five equations, five out of nine angular errors for each block can be identified [10].

4 Experimental validation

4.1 Estimation of volumetric errors

The problems with the conventional formulation of laser step diagonal measurement, and the effectiveness of its proposed formulation, are experimentally validated by an application example to a three-axis vertical-type high-precision commercial machining center.

The machine configuration is shown in Fig. 4. It has three orthogonal linear axes, which are all driven by a ball screw and a servo motor with a slide guideway. Its positioning resolution is $0.1 \mu\text{m}$ in all the axes. The machine's strokes are: X: 900mm , Y: 500mm , Z: 350mm. For laser measurements, a laser doppler displacement meter, MCV-500 by Optodyne, Inc. is used. Laser beam directions are aligned by using a quad-detector, LD42 by Optodyne, Inc. The step diagonal measurements are done with the step size $a_x = a_y = a_z = 10 \text{ mm}$, over the entire range of $120 \text{ mm} \times 120 \text{ mm} \times 120 \text{ mm}$ (i.e. 12 blocks in X, Y, and Z directions). Figure 6 shows the experimental setup of laser step diagonal measurement.

First, volumetric errors are estimated by the conventional formulation (2). Figures 7 to 9 show estimated position errors with respect to the reference position (“Estimated by conventional formulation”). For each of step diagonal measurement, the same measurement is repeated by five times. Figures 7 to 9 plot the mean of estimated errors by the marks “o”, as well as their variation at each measurement point by horizontal parallel lines (“=”).

For the comparison, linear positioning errors in X, Y, and Z directions, $e_x(x(k))$, $e_y(y(k))$, and $e_z(z(k))$, were measured by using the same laser interferometer aligned directly toward X, Y, and Z directions, respectively. The straightness errors in X, Y, and Z directions were measured by using a laser displacement sensor, LK-G10 by Keyence Corp. (measurement

resolution: $0.01 \mu\text{m}$), and an optical flat as the straight-edge (according to the manufacturer's calibration chart, its straightness error is $< \text{PV } \lambda/4$, $\lambda = 0.6328\mu\text{m}$). The squareness errors of X-Y, Y-Z, X-Z axes were measured by using the same laser displacement sensor, and the square-edge by Fujita Works, Ltd. (according to the manufacturer's calibration chart, its squareness error is $\leq 0.5 \mu\text{m} / 150 \text{ mm}$). Measured position errors in the direction normal to the feed directions, $e_y(x(k))$, $e_z(x(k))$, \dots , are given by combining measured straightness and squareness errors. In Figs. 7 to 9, these measured values are also plotted ("Measured by using artefact"). Similarly as the estimated values, the same measurement was repeated by five times, and their mean values as well as their variation are plotted in the figures.

Then, volumetric errors are estimated based on the proposed formulation of step diagonal measurements presented in Section 3.2, by using displacement profiles in ppp-, npp-, pnp-, X-, Y-, and Z- directions. First, we assume that the machine's angular errors are negligibly small. Estimated profiles are also plotted in Figs. 7 to 9 ("Estimated by proposed formulation"). Note that in all the cases, the coordinate system is defined as shown in Eq. (17).

Table 1 summarizes measured and estimated straightness and squareness errors. Here, the straightness error is defined by the maximum variation of mean values of normal errors (for example, $e_y(x(k))$ for the straightness error of X axis to the Y direction) from their least-square mean line. The squareness errors are defined by the gradient of the least-square mean line of $e_x(y(k))$ (X-Y), $e_x(z(k))$ (X-Z), and $e_z(y(k))$ (Y-Z) with respect to that of $e_y(x(k))$, $e_z(x(k))$, and $e_y(z(k))$, respectively.

From Figs. 7 to 9 and Table 1, it can be clearly observed that, when the conventional formulation (2) is used, the estimated volumetric errors from step diagonal measurements have significant estimation errors. The estimation error is particularly large in the estimates

of linear positioning errors in Y and Z directions (at maximum about 22 μm over 120mm in the Z direction).

In overall, volumetric errors of the measured machine are smaller than typical general-purpose machining centers in the market. The straightness errors of X, Y, and Z axes are all smaller than 1 μm . Considering the measurement uncertainties associated with the laser doppler displacement meter or the artefacts, it is difficult to draw any conclusion from the comparison in straightness errors. On the other hand, the squareness errors of the measured machine are relatively larger, and thus clearer comparison of measured and estimated values are possible. Fig. 8(a) (\rightarrow the squareness of X-Y), Fig. 9(a) (\rightarrow the squareness of X-Z), and Fig. 9(b) (\rightarrow the squareness of Y-Z), show that the conventional formulation of step diagonal measurements results in larger estimation errors (see also Table 1). For example, as is shown in Fig. 8(a), the measured squareness error between X and Y axes is -1.4 $\mu\text{m} / 120 \text{ mm}$. The conventional formulation of step diagonal measurements gives its estimate of 3.2 $\mu\text{m} / 120 \text{ mm}$. The estimate by the proposed formulation is -1.2 $\mu\text{m} / 120 \text{ mm}$. The estimated by the proposed formulation show better match with the measured value. Similar observation can be made for all the squareness errors shown in Table 1.

4.2 Identification of angular errors

A small difference between measured volumetric errors and their estimates by the proposed formulation may be caused by the machine's angular errors. The angular errors are estimated by applying the formulation (24)~(28). Note that all the necessary diagonal displacements can be obtained by performing three measurements moving the mirror in the sequence of X \rightarrow Y \rightarrow Z (i.e. D \rightarrow C \rightarrow B \rightarrow F in Fig. 5 in pnp measurement), Y \rightarrow Z \rightarrow X (D \rightarrow A \rightarrow E \rightarrow F),

Z→X→Y (D→H→G→F) for each diagonal.

Figure 10 shows estimated angular errors by using the formulation (24)~(28). Compared to actual angular errors of the experimental machine, the estimates in Fig. 10 are clearly too large.

For example, from Eqs. (24) and (26), $\Delta\epsilon_x(x(k))$ can be estimated by:

$$\Delta\epsilon_x(x(k)) = \frac{\sqrt{3}}{2a} \{R_{AD, npp}(N-k) - R_{BC, npp}(N-k) - R_{DA, pnp}(k) + R_{CB, pnp}(k)\} \quad (29)$$

where it is assumed that $a_x = a_y = a_z = a$ for the simplicity of computation. Suppose that measured diagonal measurements have an uncertainty of $0.1 \mu\text{m}$ in one block. From Eq. (29), it is observed that this measurement uncertainty may cause the estimation uncertainty of $\Delta\epsilon_x(x(k))$ up to 3.5×10^{-5} rad at the worst case ($a = 10 \text{ mm}$). In 12 blocks, this may be accumulated to $\epsilon_x(x(12)) = 4.2 \times 10^{-4}$ rad. To make the estimation uncertainty sufficiently small to evaluate angular errors on typical machining centers, the uncertainty of laser diagonal measurements must be much smaller than $0.1 \mu\text{m}$ for one block ($10\sqrt{3} \text{ mm}$), which is practically quite difficult in a typical factory environment. We conclude that, although it is mathematically possible to estimate a part of angular errors by the formulation presented by Soons [10], it is practically difficult under typical uncertainty of laser measurement in a factory environment.

5 Conclusion

The conventional formulation of the step diagonal measurement proposed by Wang [7] is valid only when the following implicit conditions are met: (1) laser beam directions are precisely aligned to nominal directions, (2) the flat mirror is precisely aligned perpendicular

to the laser beam direction, and (3) the machine's angular errors are sufficiently small. An inherent problem with the conventional formulation is that it is generally not possible to meet (1) and (2) by the adjustment of the setup, when volumetric errors of the machine are unknown. The new formulation proposed in this paper suggests that linear positioning errors must be independently measured, and then normal error components (namely, straightness and squareness error components) can be identified by using step diagonal measurements even under the existence of setup errors.

As an application example, the proposed scheme was applied to estimate three-dimensional volumetric errors on a machining center of the positioning resolution of $0.1 \mu\text{m}$. Experimental results indicated that the proposed formulation resulted in much smaller estimation errors than those by the conventional formulation. Based on the proposed formulation, the squareness error of X-Y, X-Z, and Y-Z axes were estimated with an estimation error of at maximum about $3 \mu\text{m}$.

The practical validity of the estimation of angular errors from step diagonal measurements based on Soons' formulation [10] was also studied in experiments. Due to the uncertainty of laser displacement measurements in a typical factory environment, we showed that it is difficult to cancel the influence of angular errors by using this formulation. Step diagonal measurements may deteriorate when the machine to be measured has significant angular errors.

References

- [1] International Standards Organization (ISO), ISO 230-1:1996 Test code for machine tools
– Part 1: Geometric accuracy of machines operating under no-load or finishing condi-

tions.

- [2] Wang, C., 2005, "A Definition of Volumetric Error," *Manufacturing Engineering*, 134, 1.
- [3] Svoboda, O., Bach P., Liotto, G., Wang, C. 2004, "Definitions and correlations of 3D volumetric positioning errors of CNC machining centers," *The IMTS 2004 Manufacturing Conference*.
- [4] American Society of Mechanical Engineers (ASME), 1992, B5.54: Methods for performance evaluation of computer numerically controlled machining centers.
- [5] International Standards Organization (ISO), 2002, ISO 230-6: Test code for machine tools, Part 6: Determination of positioning accuracy on body and face diagonals (diagonal displacement tests).
- [6] Chapman, M. 2003, "Limitations of laser diagonal measurements," *Precision Engineering*, 27, 401-406.
- [7] Wang, C., 2000, "Laser vector measurement technique for the determination and compensation of volumetric positioning errors. Part 1: Basic theory," *Review of Scientific Instruments*, 71, 10, 3933-3937.
- [8] Wang, C., 2003, Vector measurement for coordinate measuring machine. U.S. Patent No. 6519043.
- [9] Ibaraki, S., Hata, T., Matsubara, A., 2009, "A New Formulation of Laser Step Diagonal Measurement – Two-dimensional Case –, ", *Precision Engineering*, 33, 1, 56-64.

- [10] Soons, J. A. 2005, "Analysis of the step-diagonal test," *Laser Metrology and Machine Performance VII*, 126-137.
- [11] Ekinici, T. O., Mayer, J. R. R, 2007, "Relationships between straightness and angular kinematic errors in machines," *International Journal of Machine Tools & Manufacture*, 47, 1997-2004.
- [12] Yang, J., Ren, Y., Wang, C., Liotto, G., 2005, "Theoretical derivations of 4 body diagonal displacement errors in 4 machine configurations," *Laser Metrology and Machine Performance VII*, 190-199.

Table 1: Measured and estimated straightness and squareness errors.

	Measured	Conventional estimation	Proposed estimation
Positioning error in X	0.8 μm	1.7 μm	–
Positioning error in Y	0.2 μm	-18.3 μm	–
Positioning error in Z	-1.1 μm	20.9 μm	–
Straightness of X axis (Y direction)	0.5 μm	0.4 μm	0.4 μm
Straightness of X axis (Z direction)	0.4 μm	0.7 μm	0.4 μm
Straightness of Y axis (X direction)	0.1 μm	0.6 μm	0.5 μm
Straightness of Y axis (Z direction)	0.2 μm	0.3 μm	0.7 μm
Straightness of Z axis (X direction)	0.3 μm	0.6 μm	0.8 μm
Straightness of Z axis (Y direction)	0.8 μm	1.1 μm	0.9 μm
Squareness of X-Y	-1.2 μm	3.2 μm	-1.4 μm
Squareness of X-Z	1.2 μm	-4.3 μm	0.1 μm
Squareness of Y-Z	2.7 μm	-3.9 μm	-0.1 μm

* All the errors are over the range of 120 mm.

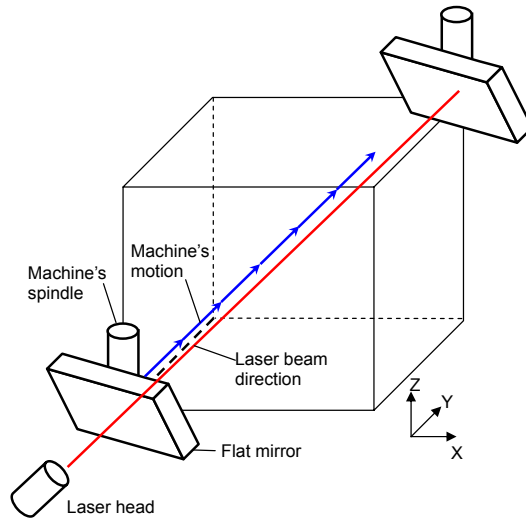

Figure 1: Schematics of diagonal measurement

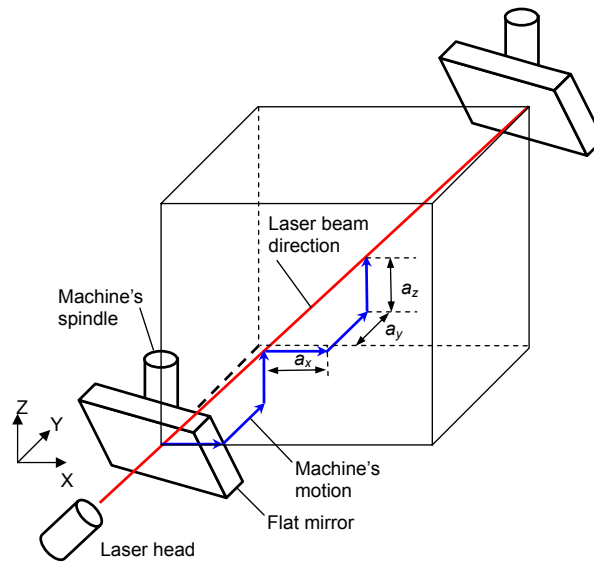

Figure 2: Schematics of 3D laser step diagonal measurement

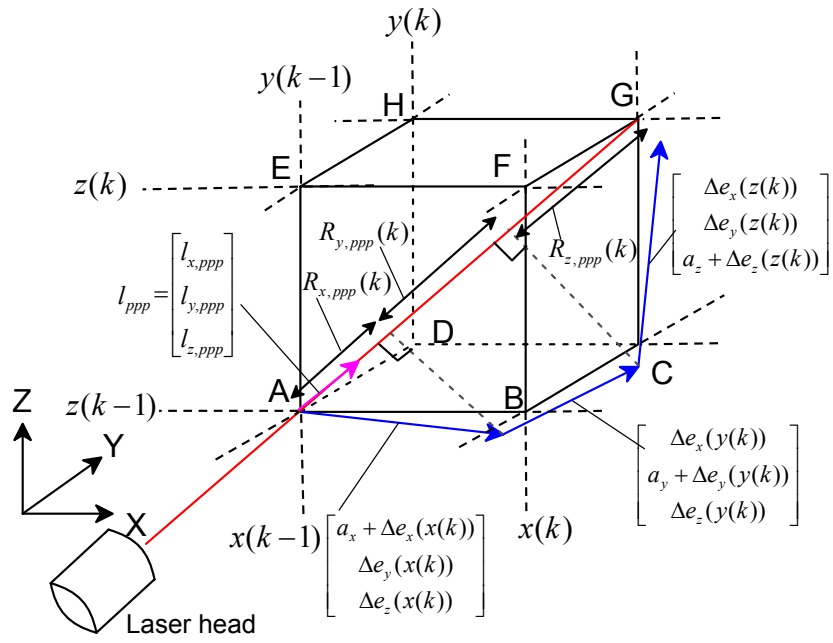

Figure 3: Volumetric errors and diagonal displacements in single block

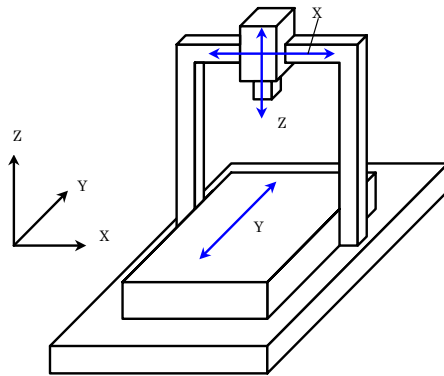

Figure 4: Configuration of experimental machine.

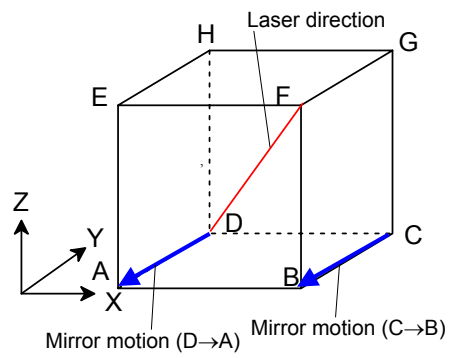

Figure 5: Comparison of two diagonal displacements for the estimation of angular errors.

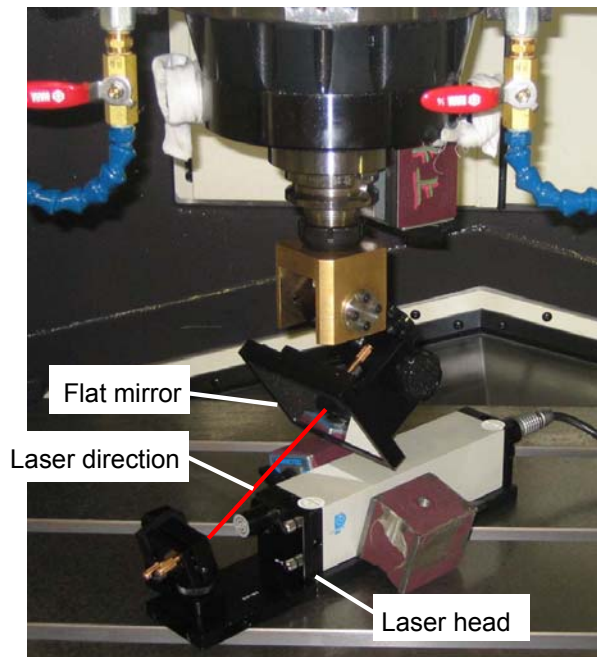
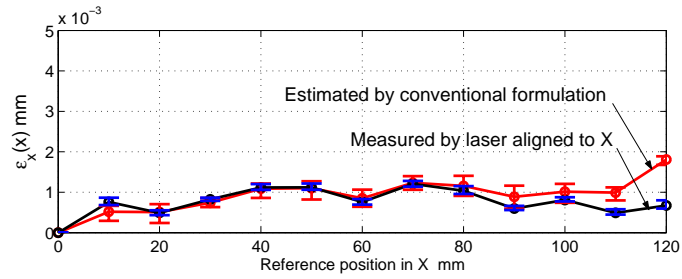
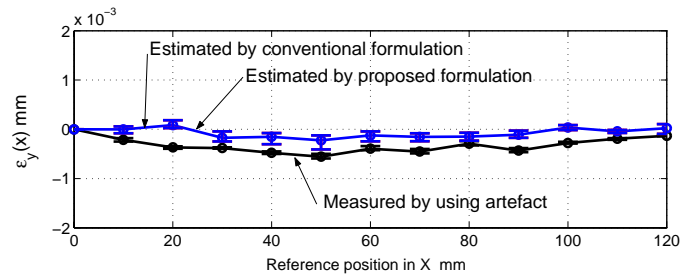

Figure 6: Experimental setup.



(a) The positioning error in X with the motion toward X, $e_x(x(k))$



(b) The positioning error in Y with the motion toward X, $e_y(x(k))$

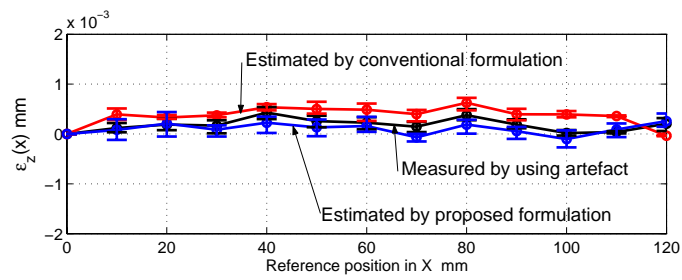

(c) The positioning error in Z with the motion toward X, $e_z(x(k))$

Figure 7: Measured and identified volumetric errors for the motion toward X direction.

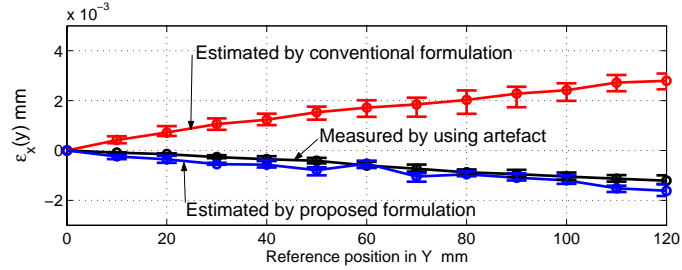

(a) The positioning error in X with the motion toward Y, $e_x(y(k))$

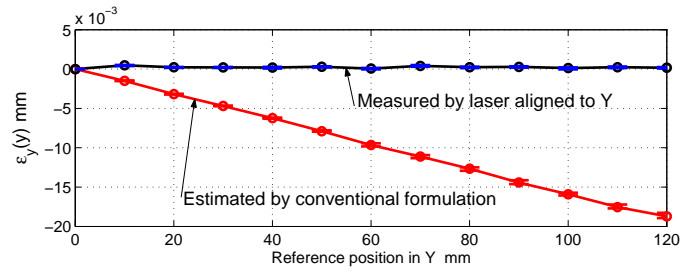

(b) The positioning error in Y with the motion toward Y, $e_y(y(k))$

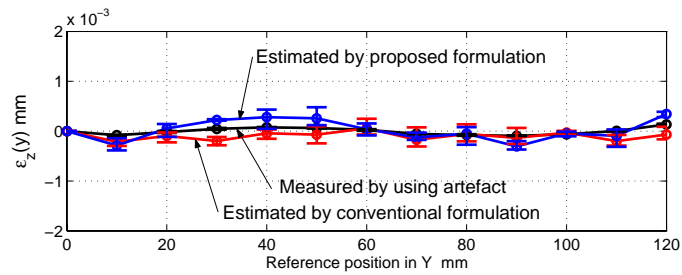

(c) The positioning error in Z with the motion toward Y, $e_z(y(k))$

Figure 8: Measured and identified volumetric errors for the motion toward Y direction.

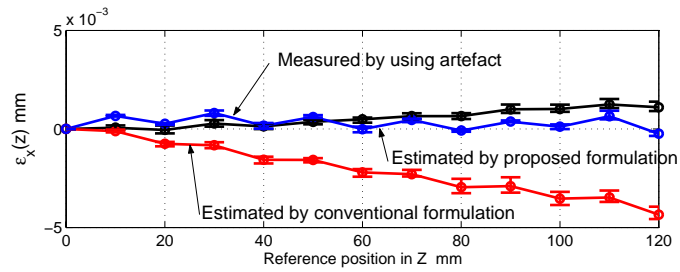

(a) The positioning error in X with the motion toward Z, $e_x(z(k))$

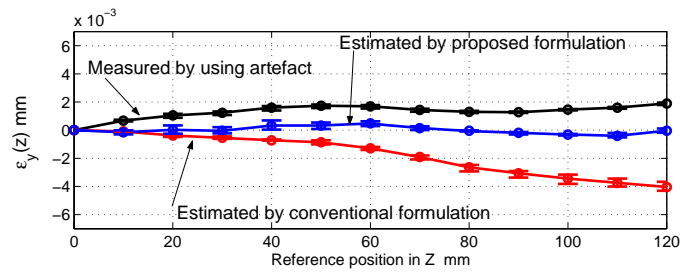

(b) The positioning error in Y with the motion toward Z, $e_y(z(k))$

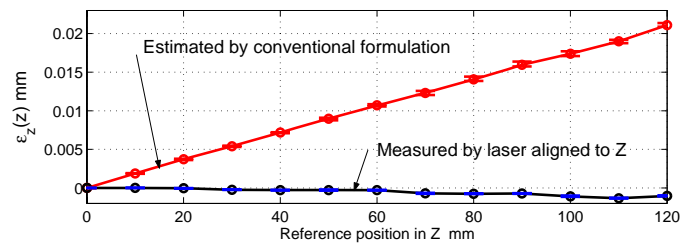

(c) The positioning error in Z with the motion toward Z, $e_z(z(k))$

Figure 9: Measured and identified volumetric errors for the motion toward Z direction.

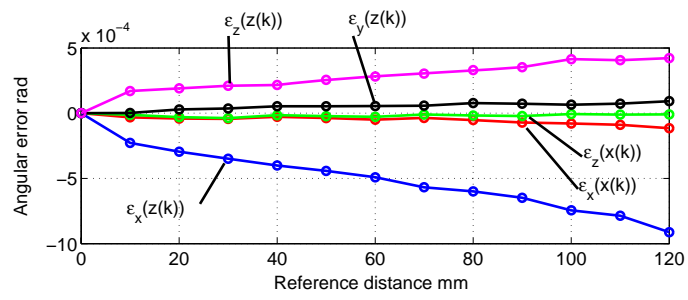

Figure 10: Estimated angular errors.