



JRC TECHNICAL REPORTS

WELL-TO-WHEELS Report Version 4.a

JEC WELL-TO-WHEELS ANALYSIS

WELL-TO-WHEELS ANALYSIS OF FUTURE AUTOMOTIVE
FUELS AND POWERTRAINS IN THE EUROPEAN CONTEXT

Authors: Robert EDWARDS (JRC), Heinz HASS (EUCAR), Jean-François LARIVÉ (CONCAWE), Laura LONZA (JRC), Heiko MAAS (EUCAR), David Rickeard (CONCAWE)

Editors: Simon Godwin (EUCAR), Heather Hamje (CONCAWE), Alois Krasenbrink (JRC), Robin Nelson (CONCAWE), Kenneth D. Rose (CONCAWE)

2014

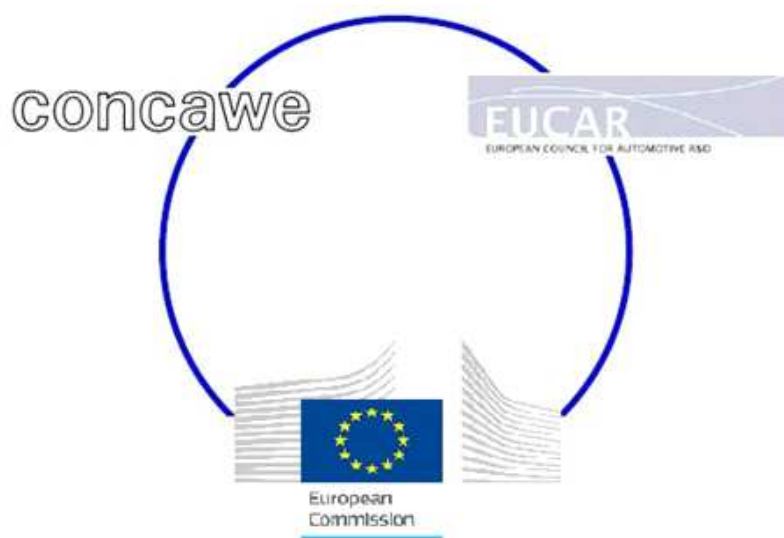

Report EUR 26236 EN

Joint
Research
Centre

European Commission
Joint Research Centre
Institute for Energy and Transport

Contact information

Laura Lonza

Address: Joint Research Centre, Via Enrico Fermi 2749, TP 230, 21027 Ispra (VA), Italy

E-mail: laura.lonza@ec.europa.eu

Tel.: +39 0332 78 3902

Fax: +39 0332 78 6671

<http://iet.jrc.ec.europa.eu/>

<http://www.jrc.ec.europa.eu/>

This publication is a Technical Report by the Joint Research Centre of the European Commission.

Legal Notice

This publication is a Technical Report by the Joint Research Centre, the European Commission's in-house science service.

It aims to provide evidence-based scientific support to the European policy-making process. The scientific output expressed does not imply a policy position of the European Commission. Neither the European Commission nor any person acting on behalf of the Commission is responsible for the use which might be made of this publication.

JRC85329

EUR 26236 EN

ISBN 978-92-79-33887-8 (PDF)

ISSN 1831-9424 (online)

doi:10.2790/95533

Luxembourg: Publications Office of the European Union, 2014

© European Union, 2014

Reproduction is authorised provided the source is acknowledged.

Printed in Italy

WELL-TO-WHEELS ANALYSIS OF FUTURE AUTOMOTIVE FUELS AND POWERTRAINS IN THE EUROPEAN CONTEXT

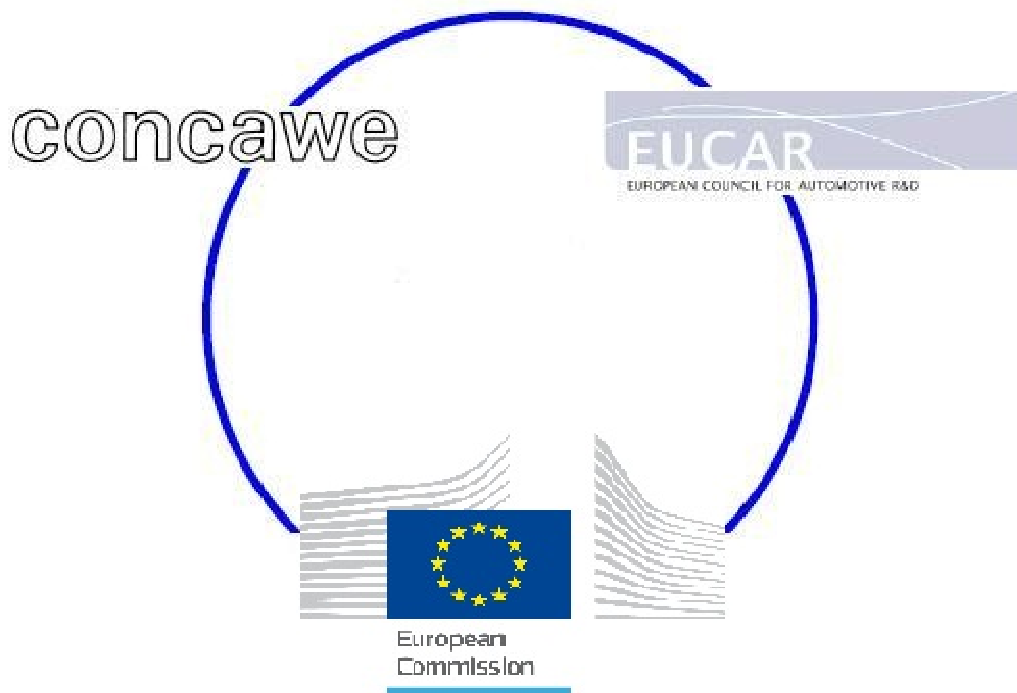

WELL-to-WHEELS Report

Version 4.a, January 2014

This report is available as an ADOBE pdf file on the JRC/IET website at:

<http://iet.jrc.ec.europa.eu/about-iec>

Questions and remarks may be sent to:

infojec@jrc.ec.europa.eu

Notes on version number:

This document reports on the fourth (4a) release of this study replacing version 3c published in July 2011. The original version 1b was published in December 2003.

The main changes and additions to the previous version are:

General:

- The structure of the report has been changed to better incorporate vehicles and fuel combinations;
- Base year for the evaluation is 2010 with a time horizon of 2020+;
- As in Version 3c of the WTW report, costs and biofuel/biomass availability are not included.

Vehicles:

- Re-evaluation of 2010 conventional and Hybrid vehicle configurations;
- Introduction of additional electrified vehicle configurations such as Plug-In Hybrid Electric Vehicles (PHEV), Range Extended Electric Vehicles (REEV) and Battery Electric Vehicles (BEV);
- Consideration of conventional and electrified vehicle configurations for 2020+;
- Change of vehicle simulation tool: ADVISOR was replaced by AVL CRUISE.

Fuels:

- Minor changes to the fossil fuel pathways based on updated estimates for flaring and venting emissions from crude production;
- Updated natural gas pathways, including the addition of an European shale gas pathway;
- Added some new biofuel pathways and deleted other pathways that no longer seem likely to be of commercial importance;
- Updated production data for biofuel pathways based on best available information from bio-industry consultations;
- Added a globally-applicable analysis of nitrous oxide emissions (N₂O) from farming based on IPCC data (Section 3.4.1.4);
- Reviewed and updated the EU electricity mix based on 2009 statistics in relation to the recharging of hybrid and battery electric vehicles.

Executive Summary

EUCAR, CONCAWE and JRC (the Joint Research Centre of the EU Commission) have updated their joint evaluation of the Well-to-Wheels energy use and greenhouse gas (GHG) emissions for a wide range of potential future fuel and powertrain options, first published in December 2003. The specific objectives of this version of the study are:

- Establish, in a transparent and objective manner, a consensual well-to-wheels energy use and GHG emissions assessment of a wide range of automotive fuels and powertrains relevant to Europe in 2020 and beyond.
- Have the outcome accepted as a reference by all relevant stakeholders.

The WTW Report contains representative pathways in order to bring out the key messages about future fuel and vehicle options. Full details of all the fuel production pathways can be obtained from the **WTT report**. Vehicle technology details can be obtained from the **TTW report**.

The main conclusions and observations are summarised below.

GENERAL OBSERVATIONS

- A Well-to-Wheels analysis is the essential basis to assess the impact of future fuel and powertrain options.
 - Both fuel production pathway and powertrain efficiency are key to GHG emissions and energy use.
 - A common methodology and data-set has been developed which provides a basis for the evaluation of pathways. It can be updated as technologies evolve.
- A shift to renewable/low fossil carbon routes may offer a significant GHG reduction potential but generally requires more total energy. The specific pathway is critical.
- Large scale production of synthetic fuels or hydrogen from coal or gas offers the potential for GHG emissions reduction, but only if CO₂ can be captured and stored.
- Transport applications may not maximize the GHG reduction potential of alternative and renewable energy resources:

ICE-BASED VEHICLES AND FUELS

Conventional Fuels / Vehicle Technologies

- Developments in gasoline / diesel engine and vehicle technologies will continue to contribute to the reduction of energy use and GHG emissions:
 - Hybridization of the conventional engine technologies can provide further energy and GHG emission benefits.
 - The efficiency gap between SI and CI vehicles is narrowing, especially for hybrid versions

Methane (CNG, CBG, SNG) and LPG fuels

- Today the WTW GHG emissions for CNG lie between gasoline and diesel.
- Beyond 2020, greater engine efficiency gains are predicted for CNG vehicles WTW GHG emissions will approach those of diesel.
 - WTW energy use will remain higher than for gasoline.

- ❑ The origin of the natural gas and the supply pathway are critical to the overall WTW energy and GHG balance.
- ❑ Producing biogas, particularly from waste materials, has a very low GHG impact, whether the biogas is used to fuel cars or produce electricity.
- ❑ Producing synthetic gas (SNG) from wind electricity and captured CO₂ (from CCS) results in low GHG emissions but needs energy.
- ❑ LPG provides a small WTW GHG emissions saving compared to gasoline and diesel.

Alternative Liquid Fuels

- ❑ A number of routes are available to produce alternative liquid fuels that can be used in blends with conventional fuels and, in some cases, neat, in the existing infrastructure and vehicles.
- ❑ The fossil energy and GHG savings of conventionally produced bio-fuels such as ethanol and bio-diesel are critically dependent on manufacturing processes and the fate of co-products. The lowest GHG emissions are obtained when co-products are used for energy production.
 - The GHG balance is particularly uncertain because of nitrous oxide emissions from agriculture.
 - Land use change may also have a significant impact on the WTW balance. In this study, we have modelled only biofuels produced from land already in arable use.
- ❑ When upgrading a vegetable oil to produce road fuel, the trans-esterification and hydrotreating routes are broadly equivalent in terms of GHG emissions.
- ❑ The fossil energy savings discussed above should not lead to the conclusion that these pathways are energy-efficient. Taking into account the energy contained in the biomass resource, the total energy involved is two to three times higher than the energy involved in making conventional fuels. These pathways are therefore fundamentally inefficient in the way they use biomass, a limited resource.
- ❑ ETBE can provide an option to use ethanol in gasoline as an alternative to direct ethanol blending. Fossil energy and GHG gains are commensurate with the amount of ethanol used.
- ❑ Processes converting the cellulose of woody biomass or straw into ethanol are being developed. They have an attractive fossil energy and GHG footprint.
- ❑ High quality diesel fuel can be produced from natural gas (GTL) and coal (CTL). GHG emissions from GTL diesel are slightly higher than those of conventional diesel, while those from CTL diesel are considerably higher.
- ❑ New processes are being developed to produce synthetic diesel from biomass (BTL), offering lower overall GHG emissions, though still high energy use. Such advanced processes have the potential to save substantially more GHG emissions than current bio-fuel options.

DME

- ❑ DME can be produced from natural gas or biomass with lower energy use and GHG emissions results than other GTL or BTL fuels. DME being the sole product, the yield of fuel for use for Diesel engines is high.
- ❑ Use of DME as automotive fuel would require modified vehicles and infrastructure similar to LPG.

- ❑ The “black liquor” route which is being developed offers higher wood conversion efficiency compared to direct gasification in those situations where it can be used and is particularly favourable in the case of DME.

EXTERNALLY CHARGEABLE VEHICLES AND FUELS

- ❑ There is a range of options for vehicles designed to use grid electricity ranging from battery vehicles (BEV) which use only electric power, to Range-Extended Electric Vehicles (REEV) and Plug-In Hybrids (PHEV) which in turn provide a greater proportion of their power from the ICE.
- ❑ While electric propulsion on the vehicle is efficient, the overall energy use and GHG emissions depend critically on the source of the electricity used.
- ❑ Where electricity is produced with lower GHG emissions, electrified vehicles give lower GHG emissions than conventional ICEs, with BEVs giving the lowest emissions
- ❑ Where electricity production produces high levels of GHG emissions, the PHEV20 configuration emits less GHG than the other xEVs. This is because it involves less electric driving than the BEV and REEV.
- ❑ The differences in performance between PHEV and REEV technologies are primarily a function of the different assumed electric range (20km vs. 80km) rather than a differentiator between the technologies themselves.

FUEL CELL VEHICLES AND HYDROGEN

- ❑ Many potential hydrogen production routes exist and the results are critically dependent on the pathway selected.
- ❑ Developments in fuel cell system, tank and vehicle technologies will allow fuel-cell vehicles to become more efficient in the 2020+ timeframe and increase their efficiency advantage over conventional vehicles.
- ❑ If hydrogen is produced from natural gas:
 - Previous versions of this study showed that WTW GHG emissions savings can only be achieved if hydrogen is used in fuel cell vehicles.
 - Hydrogen from NG used in a fuel cell at the 2020+ horizon has the potential to produce half the GHG emissions of a gasoline vehicle.
- ❑ Electrolysis using EU-mix electricity or electricity from NG results in GHG emissions two times higher than producing hydrogen directly from NG and gives no benefit compared with a gasoline vehicle.
- ❑ Hydrogen from non-fossil sources (biomass, wind, nuclear) offers low overall GHG emissions.
- ❑ For hydrogen as a transportation fuel virtually all GHG emissions occur in the WTT portion, making it particularly attractive for CO₂ Capture & Storage.
- ❑ Using hydrogen as a cryo-compressed fuel increases GHG emissions by about 10% compared to the compressed gaseous form with 70MPa.

ALTERNATIVE USES OF PRIMARY ENERGY RESOURCES

At the 2020+ horizon:

- CNG as transportation fuel only provides small savings because its global GHG balance is close to that of the gasoline and diesel fuels it would replace.
- With the improvements expected in fuel cell vehicle efficiency, production of hydrogen from NG by reforming and use in a FC vehicle has the potential to save as much GHG emission as substituting coal by NG in power generation
- Using farmed wood to produce hydrogen by reforming saves as much GHG emission per hectare of land as using the wood to produce electricity in place of coal and saves more GHG emissions per hectare than producing conventional or advanced biofuels.
- When sourcing wind electricity for transport fuels, hydrogen production and use in FCEV is more efficient than the application of synthetic diesel or methane in ICE-based vehicles.
- Using wind electricity to produce hydrogen and using it in FCEV saves slightly less GHG emissions than substituting NG CCGT electricity.
- Using wind electricity as a substitute for coal electricity is the most efficient option for GHG savings.

Acknowledgments

This JEC Consortium study was carried out jointly by experts from the JRC (EU Commission's Joint Research Centre), EUCAR (the European Council for Automotive R&D), and CONCAWE (the oil companies' European association for environment, health and safety in refining and distribution), assisted by experts from Ludwig-Bölkow-Systemtechnik GmbH (LBST) and AVL List GmbH (AVL).

Main Authors, Well-to-Wheels (WTW) Report

H. Hass	EUCAR
H. Maas	EUCAR
R. Edwards	JRC
L. Lonza	JRC
J-F. Larivé	CONCAWE
D. Rickeard	CONCAWE

JEC Scientific Advisory Board

R. Edwards	JRC
S. Godwin	EUCAR
H. Hamje	CONCAWE
H. Hass	EUCAR
A. Krasenbrink	JRC
L. Lonza	JRC
H. Maas	EUCAR
R. Nelson	CONCAWE
A. Reid	CONCAWE
K. Rose	CONCAWE

JRC Task Force

A. Agostini	JRC
R. Edwards	JRC
J. Giuntoli	JRC
M. Kousoulidou	JRC
L. Lonza	JRC
A. Moro	JRC

EUCAR Task Force

T. Becker	Opel
M. Bippes	VW
V. Boch	Renault
H-P. Deeg	Porsche
S. Finke	VW
A. Gerini	Fiat
H. Hass	Ford
E. Holder	Daimler
E. Iverfeldt	Scania
L. Jacobsson	Volvo
L. Johansson	Volvo
J. Koelch	BMW
H. Maas	Ford
F. Novel-Cattin	Renault
B. Perrier	PSA
W. Prestl	BMW
A. Roj	Volvo
A. Schattauer	BMW
J. Wind	Daimler

CONCAWE Task Force

F. Bernard	TOTAL
S. Boreux	TOTAL
V. Court	CONCAWE
C. Diaz Garcia	Repsol
J. Farenback-Brateman	ExxonMobil
S. Kuusisto	Neste Oil
H. Hamje	CONCAWE
J-F. Larivé	CONCAWE
R. Malpas	Shell
E. Marin	Repsol
C. Olivares Molina	CEPSA
C. Price	Shell
A. Rankine	BP
A. Reid	CONCAWE
D. Rickeard	CONCAWE
K. Rose	CONCAWE
T. Venderbosch	CONCAWE

LBST (Well-to-Tank Consultant)

W. Weindorf

AVL List GmbH (Tank-to-Wheels Consultant)

A. Huss
R. Albrecht
E. Morra

Table of contents

1	Study objectives and organisational structure	13
2	Scope and methodology	15
2.1	WTW versus LCA	17
2.2	Scale, availability and cost	18
2.3	WTT approach	19
2.3.1	Pathways and processes	19
2.3.2	Incremental approach	19
2.3.3	Co-product credits	20
2.3.4	Other factors of importance for biofuels	21
2.3.5	Data sources	22
2.3.6	A note on Carbon Capture and Storage (CCS)	22
2.4	TTW approach	23
2.4.1	Vehicle data and performance	23
2.4.2	Vehicle simulations	24
2.4.3	Reference driving cycle	24
2.5	WTW integration	25
2.6	Applicability to other vehicle configurations	26
3	ICE based Vehicles and Fuels	27
3.1	Vehicles considered for 2010/2020+	27
3.1.1	Gasoline and Diesel vehicles	28
3.1.2	Hybrid gasoline and hybrid diesel vehicles	29
3.1.3	Methane fuel vehicles (CNG, CBG, SNG)	29
3.1.4	LPG vehicles	30
3.2	Conventional gasoline and diesel fuel	30
3.2.1	Gasoline and Diesel production	30
3.2.2	Energy and GHG balance	30
3.3	Methane (CNG, CBG, SNG) and LPG fuels	32
3.3.1	CNG production and availability	32
3.3.2	Biogas (CBG) production	33
3.3.3	Synthetic natural gas (SNG) from (renewable) electricity	33
3.3.4	LPG production and distribution	33
3.3.5	Energy and GHG balance	33
3.4	Alternative liquid fuels / components	37
3.4.1	Ethanol, Biodiesel (FAME/FAEE), and HVO	38
3.4.1.1	Sources and manufacturing processes of ethanol	38
3.4.1.2	Sources and manufacturing processes of bio-diesel (FAME/FAEE)	40
3.4.1.3	Hydrotreated Vegetable Oil (HVO)	41
3.4.1.4	N ₂ O emissions from agriculture	41
3.4.1.5	Energy and GHG balance	41
3.4.1.6	Impact of land use changes on GHG balances	52
3.4.1.7	Other environmental impacts of biofuels production	52
3.4.2	MTBE and ETBE	53
3.4.3	Synthetic Diesel fuels and DME	55
3.4.3.1	Sources and manufacturing processes	55
3.4.3.2	Energy and GHG balances	57

4	Externally chargeable vehicles and fuels	60
4.1	Vehicles	60
4.1.1	Plug-in Hybrid Electric Vehicles (PHEV)	62
4.1.2	Range-Extended Electric Vehicles (REEV)	62
4.1.3	Battery Electric Vehicles (BEV)	62
4.1.4	xEV operational strategies	63
4.2	Electricity production, transmission and distribution	63
4.3	2020+ Energy and GHG balances	64
4.4	Fuel combinations in PHEV and REEV	70
5	Fuel Cell Vehicles (FCEV) and Hydrogen	73
5.1	Hydrogen fuelled Vehicles	73
5.1.1	Fuel Cell Electric Vehicle (FCEV)	74
5.1.2	Range extended electric vehicle – FC (REEV-FC)	75
5.2	Hydrogen production routes and potential	76
5.2.1	Thermal production	76
5.2.2	Electrolysis	77
5.2.3	Hydrogen potential	77
5.3	Distribution and refuelling infrastructure	77
5.4	Energy and GHG balances	78
5.5	Fuel combinations REEV-FC	84
6	Alternative uses of primary energy resources	86
6.1	Natural gas	87
6.2	Biomass	88
6.3	Wind	90
	Acronyms and abbreviations used in the WTW study	93

1 Study objectives and organisational structure

EUCAR, CONCAWE and JRC (the Joint Research Centre of the EU Commission) have updated their joint evaluation of the Well-to-Wheels energy use and greenhouse gas (GHG) emissions for a wide range of potential future fuel and powertrain options, first published in December 2003. The objectives of this version of the study are:

- Establish, in a transparent and objective manner, a consensual well-to-wheels energy use and GHG emissions assessment of a wide range of automotive fuels and powertrains relevant to Europe in 2020 and beyond.
- Have the outcome accepted as a reference by all relevant stakeholders.

Cost and potential availability of alternative pathways were evaluated in version 1 and 2 of this study. With the development of specific legislation on introduction of alternative fuels, these issues have been receiving a lot of attention and generated a lot of debate. In this version 4 we opted out of this and concentrated on the evaluation of energy and GHG balances.

Notes:

- The study is not a Life Cycle Assessment. It does not consider the energy or the emissions involved in building the facilities and the vehicles, or the end of life aspects. It concentrates on fuel production and vehicle use, which are the major contributors to lifetime energy use and GHG emissions.
- No attempt has been made to estimate the overall “cost to society” such as health, social or other speculative cost areas.
- Regulated pollutants have only been considered in so far as all plants and vehicles considered are deemed to meet all current and already agreed future regulations.

This study was undertaken jointly by the Joint Research Centre of the EU Commission, EUCAR and CONCAWE. It was supported by the structure illustrated in the diagram below.

Supporting Structure

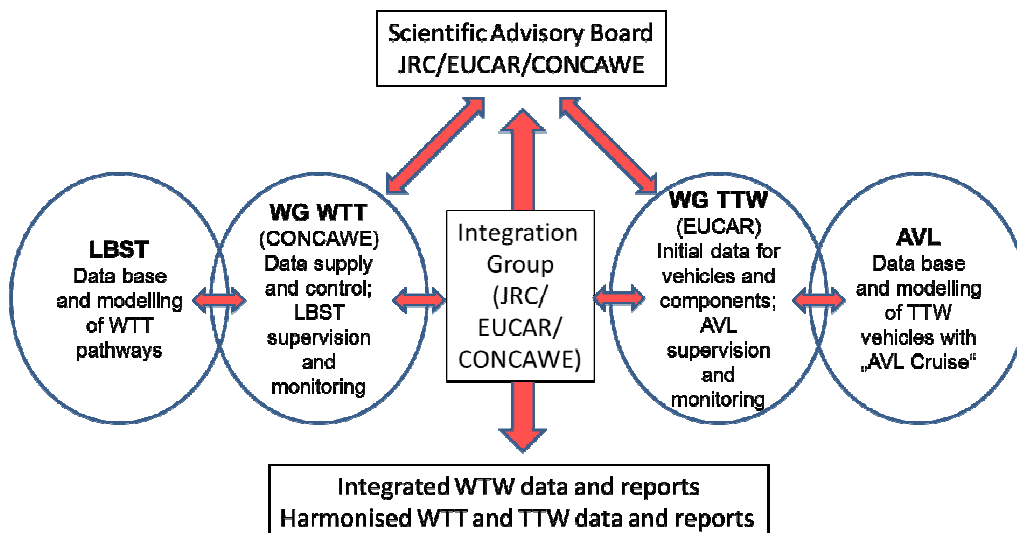

The “Well to Tank” Working Group was coordinated by CONCAWE/JRC assisted by Ludwig-Bölkow-Systemtechnik GmbH (LBST), a consultancy firm with a proven track record in WTW assessment and which had a major involvement in previous work by General Motors [GM 2002] and the German Transport Energy Strategy Partnership (TES). JRC Institute for Energy and Transport (JRC IET) provided a major contribution to the bio-fuel pathways characterization and the estimation of future biomass availability.

The “Tank to Wheels” Working Group was coordinated by EUCAR/JRC. EUCAR supplied the vehicle data, the engines energy efficiency maps and adaptation procedures. The simulation code adaptation (AVL Cruise) and the simulated fuels-vehicle assessments were contracted to the AVL GmbH.

JRC IET contributed to an ADVISOR / AVL Cruise comparison (see **TTW report**).

The Integration Group was chaired by JRC IET and supervised by a Scientific Advisory Board representing the three partners.

2 Scope and methodology

The Well to Tank (WTT) evaluation accounts for the energy expended and the associated GHG emitted in the steps required to deliver the finished fuel into the on-board tank of a vehicle (**Table 2-1**).

The Tank to Wheels (TTW) evaluation accounts for the energy expended and the associated GHG emitted by the vehicle/fuel combinations as shown in **Table 2-2**.

The related methodologies and findings are fully documented and discussed in the companion “Well-to-Tank” and “Tank-to-Wheels” reports. The main assumptions are summarised in section 2 of this report.

Energy use and GHG emissions are associated with both fuel production and vehicle use; hence it is only by considering the whole pathway that the overall impact of fuel and vehicle choices can be seen. This report describes the Well to Wheels (WTW) integration for the fuel/vehicle combinations considered, including:

- An overall assessment of the energy required and the GHG emitted per unit distance covered,
- Considerations of alternative (outside the road transport sector) and optimum use of limited energy resources.

In this version we have not attempted to estimate the cost or potential availability of alternative fuel and vehicle options. We consider that these questions are best handled separately.

Sections 3 to 5 of this report cover the different fuel/vehicle options, under the three main headings of ICE based vehicles and fuels, vehicles able to accept external electrical charge and hydrogen fuel cells. Section 6 covers alternative uses of energy resources. The study is forward-looking and aims to provide information to guide future choices of fuel and vehicle technologies.

The evaluation of individual pathways calls for sound comparison of the various options from a variety of angles. We have endeavoured to shed some light on this by answering the questions:

- What are the alternative pathways to produce a certain fuel and which of these hold the best prospects? This may include alternative feedstocks or different choices in the production process.
- What are the alternative uses for a given primary energy resource and how can it be best used?

Our aim has been to evaluate the impact of fuel and/or powertrain substitution in Europe on global energy usage and GHG emissions balance, i.e. taking into account induced changes in the rest of the world. This is particularly important for fuels produced from biomass where careful consideration of co-products is essential to a good understanding and where use of land to produce fuel crops can have implications for agriculture around the world.

Throughout this study we have endeavoured to remain as neutral and objective as possible. In any such study, however, many choices have to be made at every step. These cannot always be based purely on scientific and technical arguments and inevitably carry an element of judgement. While we do not pretend to have escaped this fact, we have endeavoured to make our choices and decisions as transparent as possible.

Amongst the data that was available we chose what we judged to be the most appropriate sources. Some of the selected assumptions, such as the set of minimum driving performance criteria, are real and tangible. Others, relating to emerging technologies, extrapolated to 2020 and beyond, are closer to expectations than assumptions. The choices made are referenced, justified and documented. The details of the calculations have been to the largest possible extent included in the appropriate appendices and workbooks to allow the reader to access not only the results but also the basic data and the main calculation assumptions.

Data sources are referenced in the WTT and TTW reports and in the Workbooks but with a few exceptions are not generally repeated in this WTW integration document full list of references for the whole study can be found in **WTW Report, Appendix 2**.

In any well-to-wheels study, there are many sources of uncertainty. A large part of the data pertains to systems or devices that do not yet exist or are only partly tested. Future pathways may include existing components that are well characterised, but also new aspects where performance figures are expectations rather than firm figures. We have addressed uncertainty in two ways. Estimates of uncertainty are included for

each individual element in a pathway and these will naturally be wider for future options that are not yet well characterised. These variability ranges are identified in the **WTT and TTW reports** and as much as possible justified. Secondly, where there are major options, these have been singled out by defining a separate pathway.

As an energy carrier, a fuel must originate from a form of primary energy, which can be either contained in a fossil feedstock or fissile material, or extracted from solar energy (biomass or wind power). Generally a given fuel can be produced from a number of different primary energy sources.

The number of conceivable fuels and fuel production routes is very large and we have included all fuels and primary energy sources that appear relevant for the foreseeable future. While we have tried to be as exhaustive as possible, certain combinations that we considered less relevant have been left out at this stage. The database is structured in such a way that new data from scientifically established changes, progress, or new applications can be easily taken into account in future updates. The following matrix summarises the main combinations of primary energy and finished fuels that have been included.

Table 2-1 Primary energy resources and automotive fuels

Fuel \ Resource	Gasoline, Diesel (2010 quality)	CNG/CBG/SNG	LPG	Hydrogen (comp., liquid)	Synthetic diesel	DME	Ethanol	MT/ETBE	FAME/FAEE	HVO	Methanol	Electricity	Heat
Crude oil	X											X ⁽⁵⁾	X ⁽⁶⁾
Coal				X ⁽¹⁾	X ⁽¹⁾	X					X	X	
Natural gas Piped		X		X ⁽¹⁾	X	X					X	X	X
Remote		X ⁽¹⁾		X	X ⁽¹⁾	X ⁽¹⁾		X			X	X	X
Shale gas		X											
LPG Remote ⁽³⁾			X					X					
Biomass							X						
Sugar beet							X						
Wheat							X	X					
Barley/rye							X						
Maize (Corn)		X ⁽²⁾					X ⁽⁴⁾						
Wheat straw							X						
Sugar cane							X						
Rapeseed									X	X			
Sunflower									X	X			
Soy beans									X	X			
Palm fruit									X	X			
Woody waste				X									X
Farmed wood				X	X	X	X				X	X	X
Waste veg oils									X	X			
Tallow									X	X			
Organic waste		X ⁽²⁾										X	X
Black liquor				X	X	X					X	X	
Wind		X			X							X	
Nuclear												X	
Electricity				X									

⁽¹⁾ with/without CCS

⁽²⁾ Biogas

⁽³⁾ Associated with natural gas production

⁽⁴⁾ EU and US sources

⁽⁵⁾ Heavy Fuel Oil

⁽⁶⁾ Heating Oil

For the vehicle calculations, a common vehicle platform representing the most widespread European segment of passenger vehicles (C-Class compact 5-seater European sedan) was used, and a number of powertrain options assessed as shown in **Table 2-2** below. Vehicle performance was calculated using the AVL CRUISE vehicle software which is a development from the ADVISOR vehicle simulation tool use in earlier versions of the study.

Key to the methodology was the requirement for all vehicle configurations to comply with a set of minimum performance criteria relevant to European customers while retaining similar characteristics of comfort, driveability and interior space. Also the appropriate technologies (engine, powertrain and after-treatment) required to comply with pollutant emission regulations in force at the relevant date were assumed to be installed. Finally fuel consumptions and GHG emissions were evaluated on the basis of the drive cycle (NEDC) currently employed for vehicle type-approval in the EU .

It is important to recognise that:

- The model vehicle is simply a comparison tool and is not deemed to represent the European average in terms of fuel consumption
- The results relate to compact passenger car applications, and should not be generalized to other segments such as Heavy Duty or SUVs (see note in section 2.5).
- No assumptions or forecasts were made regarding the potential of each fuel/powertrain combination to penetrate the markets in the future. In the same way, no consideration was given to availability, market share and customer acceptance.

Table 2-2 Automotive fuels and powertrain combinations

Powertrain \ Fuel	PISI	DISI	DICI	Hybrid DISI	Hybrid DICI	PHEV20 DISI	REEV80 SI	PHEV20 DICI	REEV80 CI*	BEV	FCEV	REEV80 FC**
Gasoline	Blue	Blue		Blue		Blue	Blue					
Gasoline E10 (market blend)	Yellow	Yellow		Yellow		Yellow	Yellow					
Gasoline E20 (high RON)	Blue	Blue		Blue		Blue	Blue					
Diesel			Blue		Blue			Blue	Light Blue			
Diesel B7 (market blend)			Yellow		Yellow			Yellow	Light Blue			
LPG	Blue	Blue										
CNG	Blue	Blue										
E85	Blue	Blue		Blue		Blue	Blue					
MTBE	Yellow	Yellow		Yellow								
ETBE	Yellow	Yellow		Yellow								
FAME			Yellow		Yellow			Yellow	Yellow			
DME			Yellow									
Syndiesel			Yellow		Grey			Yellow	Yellow			
HVO			Yellow		Yellow			Yellow	Yellow			
Electricity						Blue	Blue	Blue	Light Blue	Blue		Light Blue
Compressed Hydrogen											Blue	Light Blue
Cryo-compressed hydrogen											Blue	Light Blue

All configurations modelled for both 2010 and 2020+ (except when stated otherwise)

Colour coding

- Blue: Modelled in detail with the vehicle simulation tool
- Light Blue: Exceptions: REEV80 FC** and REEV80 CI* only modelled for 2020; REEV80 CI* modelled for two different layouts
- Yellow: Derived from simulations using the relevant fuel properties

In **Table 2-2** the vehicle/powertrain configurations are:

- **PISI / DISI:** Port Injection / Direct Injection Spark Ignited engine
- **DICI:** Direct Injection Compression Ignited engine
- **PHEV20:** Plug-In Hybrid Vehicle with an electric driving range of 20km (NEDC)
- **REEV80:** Range Extended Electric Vehicle with an electric driving range of 80km (NEDC)
- **BEV:** Battery Electric Vehicle
- **FCEV:** Fuel Cell Electric Vehicle
- **REEV80 FC:** Range Extended Fuel Cell Vehicle with an electric driving range of 80km (NEDC) and a Fuel Cell as a Range Extender.

2.1 WTW versus LCA

This study estimates the energy use and GHG emissions in the production of a fuel and its use in a vehicle. We apply the term 'well-to-wheels' to this process for fuels from all sources, because although the term is most applicable to conventional crude oil resources, it is widely used and understood.

We are sometimes asked why we do not include the energy use and GHG emissions in the production and end of life disposal of the vehicle and fuel production/distribution facilities to make a true Life Cycle Assessment.

Life Cycle Assessment (LCA) is a broader methodology that can be used to account for all the environmental impacts of an industrial process. This could include not only energy and GHG (as in the WTW) but also the

consumption of all the materials needed for the production process, water requirements, emission of many kinds of pollutants (liquid, gaseous etc). In other words, the LCA methodology considers in detail the footprint of any given process. As a consequence, much wider data sets are required and data calculations tend to be more complex, less transparent and comparability might be more limited.

Hence, the LCA methodology has the potential to provide full information on a specific process and – theoretically – follows a standardised methodology, laid out by the International Standards Organization [ISO 2006 (1) and (2)]. However, this method is more complex to implement, particularly for new processes, where system boundaries need to be defined, and data describing (a vast amount of) LCA variables can be lacking or not shared among stakeholders. Since our objective is to give a comparison between different options the full LCA methodology has not been deemed suitable.

Studies have been carried out in the USA [MIT 2008], [Baumann 2012] including vehicle production and end of life disposal. The results generally indicate that vehicle production and end of life disposal make a significant, but fairly constant contribution to the overall lifetime performance. For example, in a mid-sized US car the GHG emission contribution is estimated in 2035 to be 21-24 g CO_{2eq}/km for gasoline, diesel and hybrid vehicles including PHEV, compared with total emissions for these vehicles from 109 to 178 g CO_{2eq}/km. The MIT study predicts that for fuel cell and battery vehicles the GHG emissions for vehicle production and disposal could rise to 30-31 gCO_{2eq}/km. So far, this broadly supports our decision to concentrate on WTW aspects, but we will keep this aspect under review as technology develops.

The WTW methodology makes the implicit assumption that energy use and GHG emissions have the same impact wherever they occur in the survey area, in this case, Europe. This is indeed true for GHG emissions which act on a global basis and is arguably applicable to energy supplies also within the overall European context. The same cannot be said for other metrics such as air pollution and water use which depend more on local conditions and effects. While these aspects are important, they need different analysis methodologies and so have not been included in our study.

2.2 Scale, availability and cost

The question of fuel availability is an important one, especially for new fuels including biofuels. In Version 2 of this study we published estimates of the amount of biofuel that could be available to Europe and produced within the EU. Since then, the discussion around biofuels has developed considerably and the market has become more global. The question of fuel availability is now a specialised area that is best handled outside this study. This topic has not been included in this report but another study provides some guidance [Lonza 2011].

The scale at which a route might be developed is relevant to the selection of appropriate energy data. For example, efficiencies might be better in a large centralised plant than in several smaller dispersed locations and we have chosen figures appropriate to the situation. For biofuels, scale issues can be important in a different way. The future demand for biofuels is likely to exceed what can be produced from European feedstocks. We have included a wide range of pathways for biofuels from European and non-European feedstocks, to cover the range of options for the future.

Cost remains an important element in the success of new vehicle and fuel options and in Version 2 of this study we included estimates of costs, both for fuels and vehicles. While this provided a useful benchmark at the time, cost estimation for future vehicles and fuels is an uncertain process and we have not continued this analysis into the current study. Vehicle technology is responding rapidly to meet targets for lower fuel consumption and tailpipe CO₂ emissions. Step-out technologies such as electric vehicles and fuel cell vehicles remain expensive compared with conventional internal combustion engine vehicles even though these too are becoming more complex and costly. Estimating how the cost of batteries and fuel cells will fall in the future is an uncertain business given the competitive and innovative nature of the motor industry today.

Conventional fuel resources (oil, natural gas, uranium) are traded on global markets which respond to a range of pressures of which the actual cost of production is just one. There is no rational way to predict fossil fuel prices and the best that can be done is to consider different scenarios. Alternative fuels including biofuels and electricity are subject to incentives, while petroleum fuels in Europe are heavily taxed, so the price paid by the customer bears little relation to the actual cost of production. Given this complexity, we consider that cost analyses are best handled in a separate specialist study and that our resources are best employed in producing robust evaluations of energy use and GHG emissions for future fuel and vehicle options.

2.3 WTT approach

This part of the study describes the process of producing, transporting, manufacturing and distributing a number of fuels suitable for road transport powertrains. It covers all steps from extracting, capturing or growing the primary energy carrier to refuelling the vehicles with the finished fuel. All details of assumptions and calculations are available in the **WTT report** and its appendices. In this update to the study we have included workbooks in the **WTT report** which give a detailed explanation of the input data and their sources. We briefly discuss below some basic choices that have been made and that have a material impact on the results.

2.3.1 Pathways and processes

Our primary focus has been to establish the energy and greenhouse gas (GHG) balance for the different routes. The methodology used is based on the description of individual processes, which are discreet steps in a total pathway, and thereby easily allows the addition of further combinations, should they be regarded as relevant in the future.

2.3.2 Incremental approach

The ultimate purpose of this study is to guide those who have to make a judgement on the potential benefits of substituting conventional fuels by alternatives. It is clear that these benefits depend on the incremental resources required for alternative fuels and the incremental savings from conventional fuels saved.

The results presented in the charts are the calculated energy use and GHG emissions for each future fuel/vehicle pathway. To understand the overall implications for this new pathway we then need to compare it with what would have happened had we continued with conventional vehicles and fuels. For example, the overall impact of introducing CNG vehicles is obtained by comparing a vehicle using conventional gasoline with the pathway for CNG.

However, because we are looking at future impacts it is not appropriate to consider just the current European situation, we need to determine the effect of using additional natural gas and less gasoline. For natural gas, it is not appropriate to consider the current EU-mix which relies on a large and declining contribution from European gas resources. Any additional demand in the future will have to be met by imports, with the most likely sources being 4000km pipeline or LNG.

At the 2020+ horizon substitution is only plausible up to a limited level, say up to a maximum of 10-15% depending on the option considered. To estimate the savings from conventional fuels we calculated how much energy and GHG emissions would be reduced in the refinery by producing less of these rather than calculating the average for fuel use today. This was done by modelling the EU-wide refining system (see figure below and more details in **WTT Appendix 3**).

Figure 2.3.2 Impact of a marginal reduction of conventional gasoline demand

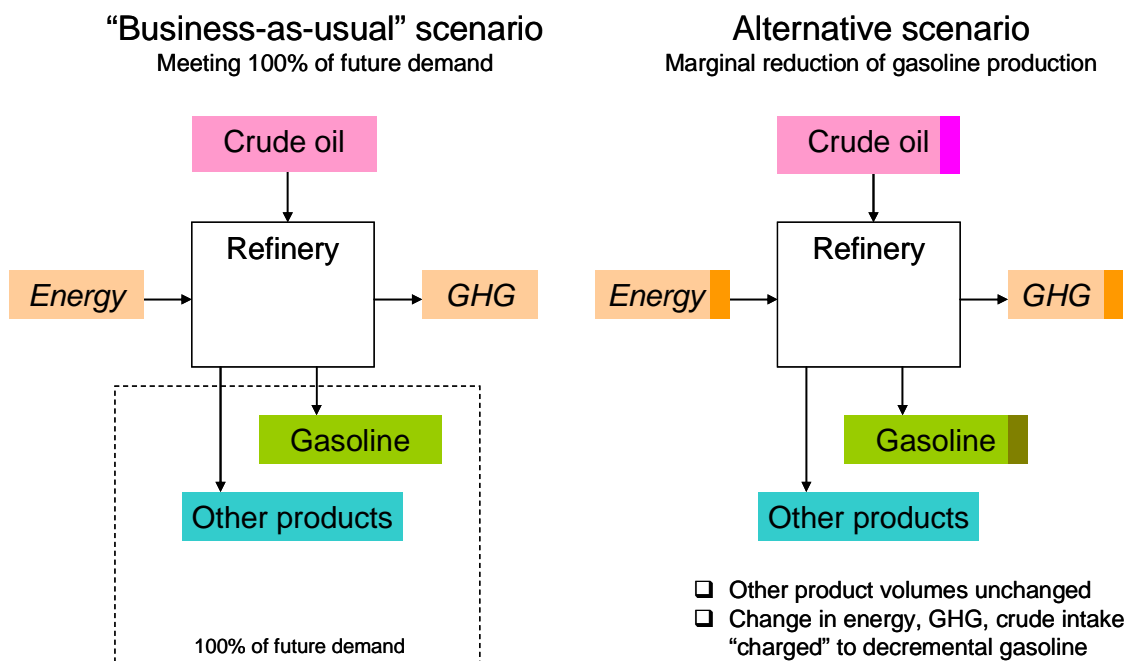

We have employed this incremental approach to the maximum extent possible, however in a few cases, most notably electricity production, there is no consensus on a practical way to assess the marginal energy source, so have reluctantly used a balanced mix of sources.

2.3.3 Co-product credits

Many processes produce not only the required fuel product but also other streams or “co-products”. This is the case for biofuels from traditional crops such as bio-diesel from rapeseed. In some cases, e.g. soya it is not always clear whether the fuel or non-fuel products are the most important. In line with the philosophy described above we endeavoured to represent the “incremental” impact of these co-products. This implies that the reference scenario must include either an existing process to generate the same quantity of co-product as the alternative-fuel scenario, or another product which the co-product would realistically replace.

The implication of this logic is the following methodology (**Figure 2.3.3**):

- All energy and emissions generated by the process are allocated to the main or desired product of that process.
- The co-product generates an energy and emission credit equal to the energy and emissions saved by not producing the material that the co-product is most likely to displace.

For example, in the production of bio-diesel from oil seeds, protein-rich material from e.g. oil seeds pressing are likely to be used as animal fodder displacing soy meal.

We strongly favour this "substitution" method which attempts to model reality by tracking the likely fate of co-products. This approach, (also known as “extension of system boundaries”), is increasingly used by scientists and is the method of choice in the ISO standards for life cycle assessment (LCA) studies. Some other studies have used "allocation" methods whereby energy and emissions from a process are arbitrarily allocated to the various products according to e.g. mass, energy content, “exergy” content or monetary value. Although such allocation methods have the attraction of being simpler to implement their outcomes in terms of energy use and GHG emissions tend to be less realistic. It is clear that the impact of a co-product must depend on what the co-product substitutes: all allocation methods take no account of this, and so are likely to give unreliable results.

Figure 2.3.3 Co-product credit methodology

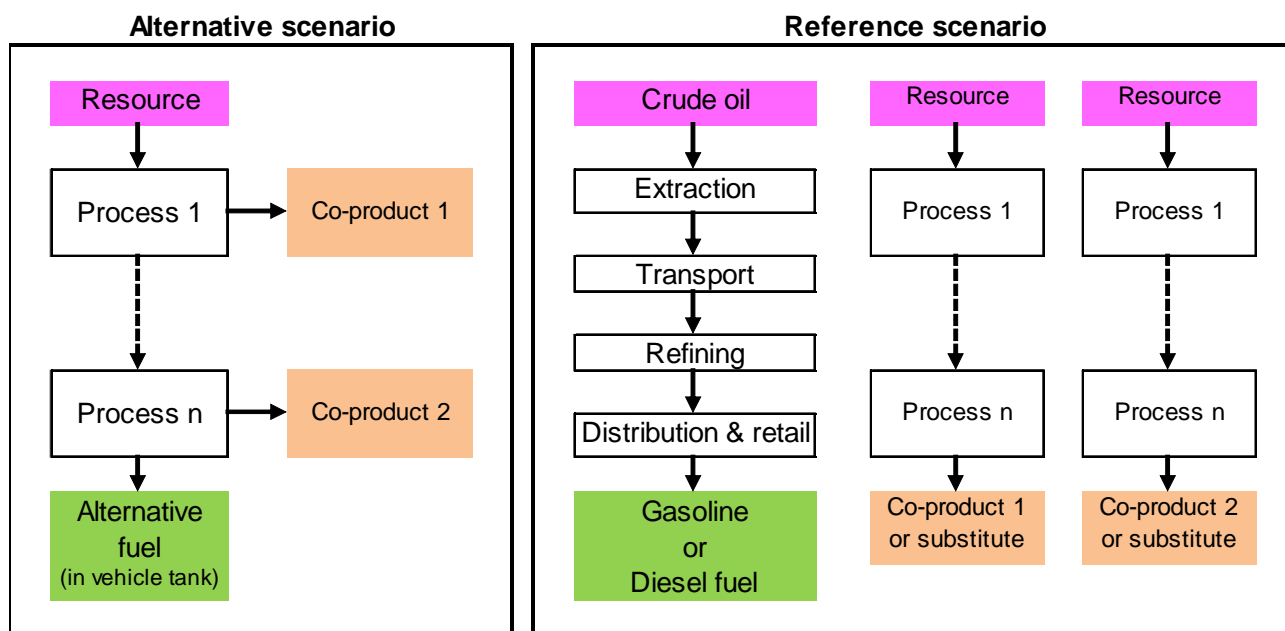

In most cases, co-products can conceivably be used in a variety of ways and we have included the more plausible ones. Different routes can have very different implications in terms of energy, GHG or cost and it must be realised that economics rather than energy use or GHG balance are likely to dictate which routes are the most popular in real life.

2.3.4 Other factors of importance for biofuels

Biofuels present particular challenges to produce reliable GHG and energy balances, because the agricultural part of the equation is complex. In addition to the impact of fossil energy used in producing and processing the crop, GHG emissions are emitted over the growing period as nitrous oxide (N₂O), a gas with 298 times the GHG potency of CO₂, as nitrogen from fertiliser and natural sources is broken down in the soil. N₂O emissions depend on soil type, fertiliser addition, the type of crop and also the weather, so they are difficult to estimate with accuracy.

In this version, we have introduced a comprehensive new model for estimating N₂O emissions using an IPCC “tier 2” approach, because it requires less detailed input data than our previous model and can be applied equally to crops grown both inside and outside the EU. Soils emit some N₂O even if they are not farmed. These can be quite significant, especially for organic soils. In previous versions of this study we have subtracted N₂O emissions for a reference case of unfertilised grassland to obtain the N₂O emissions directly attributable to biofuel production. With the new GNOC modelling tool used in this version a reference case is no longer needed, because the emissions from an unfertilised control plot are subtracted internal to the model.

The second factor affecting agricultural production is Land Use Change. Crop cultivation may directly change the soil carbon reservoir, for example where forest or grassland is converted to arable use. In some cases the carbon store may increase where a perennial crop replaces annual arable crops. Such Direct Land Use Change (DLUC) can take several years or even decades to reach equilibrium and the effects may in some cases be large. DLUC refers to effects on the land where the biofuel crop itself is produced. Changes in land use may also be affected indirectly by biofuels, through the expansion of croplands to replace the land lost to food production where biofuels are produced. GHG emissions may result from removal of existing forest or other vegetation as well as changes in the soil carbon reservoir of new land brought into cultivation. These effects are referred to as Indirect Land Use Change (ILUC)

Both DLUC and ILUC can be important in understanding the impact of biofuels, but they are difficult to estimate and still the subject of debate and research. For this reason, we have not included LUC effects in the biofuel pathways, but have included a short explanatory section in the **WTT report**.

These issues are all discussed in **WTT report section 3.4.1**.

2.3.5 Data sources

The collaboration with LBST allowed us access to the comprehensive database compiled by the TES consortium and in the course of the study carried out by General Motors [GM 2002]. With the agreement of these two organisations we have used the information extensively. Over the years the existing data has been extensively reviewed and updated, and a number of new processes and pathways not hitherto considered have been added.

An objective of our study has always been to present our results in a transparent way. In this version we have made renewed efforts to ensure that inputs for comparable pathways are all based on the same data, and to report these inputs clearly. The **WTT report** includes workbooks for each set of pathways that give a detailed explanation of the input assumptions and the source of the data.

2.3.6 A note on Carbon Capture and Storage (CCS)

The concept of isolating the CO₂ produced in combustion or conversion processes and injecting it into suitable geological formations has been gaining credibility in the last few years. There are many such structures available in most areas of the globe from depleted gas and oil fields to salt domes and aquifers. CO₂ injection can also be used to enhance and prolong production from ageing oil and gas fields. Pilot projects are already in operation in the oil and gas industry. The schemes include separation of CO₂ from other gases, compression and liquefaction, transport (by pipeline or ships) to the point of injection and injection under pressure.

Separation of CO₂ from other gases is a well-established process. In combustion applications using air, scrubbing CO₂ out of the flue gases is feasible although very large equipment is required because of the large gas volumes. Oxy-combustion is more favourable from this point of view as it delivers virtually pure CO₂, although additional energy needs to be expended in the air separation unit. Reforming and gasification processes deliver CO/hydrogen/CO₂ mixtures or mostly hydrogen/CO₂ after the shift reaction. In these cases CO₂ scrubbing is more straightforward. In some cases, for example before syngas is fed to a Fischer-Tropsch reactor, CO₂ scrubbing is required irrespective of the CCS option.

Following capture at the point of emission, CO₂ must be compressed and liquefied, transported to the point of storage and injected. Transport is usually envisaged via pipelines when distance between production and storage sites is relatively short. Long-distance transport by ship has also been considered. We have accounted for the energy required for compression to 15 MPa. No additional energy has been included under the assumption that this pressure level would be sufficient to transport CO₂ by pipeline over a reasonable distance (typically 100-150 km) and inject it into the geological storage.

In attempting to assess the CO₂ benefit and energy requirement of CCS in these different cases we found many literature references. In particular we were guided by a study by the IEA's Greenhouse gas R&D programme [IEA 2005]. As CCS has so far only been applied on a limited scale in very few locations worldwide, all references refer to theoretical studies. These do not always include details of the envisaged flow schemes and/or full comparative data between the case without CCS and the case with CCS. Many of the process schemes are complex, involving multiple sources of CO₂. In a GTL plant, for instance, CO₂ is emitted by the syngas production process, the Fischer-Tropsch process and the power plant. Each of these sources produces a different gas mixture which would require different systems to separate the CO₂. Generally therefore the degree of CO₂ recovery, the energy involved and the cost of the installations required will depend on which gas streams are being tackled.

Because of all these uncertainties and possible lack of consistency between the sources, we consider that the figures for the CCS schemes presented in this report should be regarded as preliminary and indicative of the potential of the technology. As more real-life applications develop, better estimates are expected to become available.

The concept can in principle be applied to many fuel production pathways. As illustration of its potential, we have included CCS in the following cases:

- Electricity from natural gas and coal (IGCC)
- LNG: CO₂ from the power plant associated to the liquefaction plant.

- Hydrogen from NG and coal: Process CO₂ after shift reaction
- GTL and CTL diesel: Process CO₂ after reforming / partial oxidation
- DME from NG: Process CO₂ after reforming

Clearly the potential benefits of CCS are much larger for certain pathways. Not surprisingly coal-based processes such as CTL stand to benefit the most as they involve low energy efficiency and high-carbon primary resource.

Hydrogen pathways involve complete decarbonisation of the feedstock and make therefore the majority of the original carbon available for capture. We have only represented a limited number of options but it stands to reason that pathways such as coal to hydrogen would show an even more favourable picture. It must also be pointed out that, in hydrogen pathways, CO₂ is already available in more or less pure form whether or not CCS is intended. As a result the extra energy requirement and cost are likely to be lower than in other schemes.

Applying CCS to LNG or GTL schemes can also offer CO₂ reduction but of a more limited nature. The justification for such schemes comes from the fact that such plants would be located very near gas or oil fields where the CO₂ could be re-injected.

2.4 TTW approach

This part of the study accounts for the energy expended and the associated GHG emitted by the vehicle/fuel combinations in the reference NEDC driving cycle.

2.4.1 Vehicle data and performance

All simulations were based on a common model vehicle, representing a typical European compact size 5-seater sedan (see reference vehicle characteristics in the **TTW report**). This vehicle model was used as a reference for the various other fuels and associated powertrain technologies combinations. The fuel consumption figures are not deemed to be representative of the average European fleet. All required data for a 2010 PISI gasoline model vehicle were collected from EUCAR member companies for their respective brand version and this data base was used to create the generic reference vehicle.

In order to obtain a valid comparison between the various powertrain/fuel combinations, it was deemed essential that they should all comply with a minimum set of performance criteria, given in the following table.

Table 2.4.1 Minimum vehicle performance criteria

		2010					2020+				
		PISI DISI DICI Hybrid SI Hybrid CI	PHEV SI PHEV CI	REEV SI	BEV	FCEV	PISI DISI DICI Hybrid SI Hybrid CI	PHEV SI PHEV CI	REEV SI REEV CI REEV FC	BEV	FCEV
Time lag for 0-100 km/h	[s]	11	11	11	11	11	11	11	11	11	11
Time lag for 80-120 km/h	[s]	11	11	11	11	11	11	11	11	11	11
Gradeability at 1 km/h	[%]	30	30	30	30	30	30	30	30	30	30
Gradeability at 10km/h	[%]	20	20	20	20	20	20	20	20	20	20
Minimum Top speed	[km/h]	180	180	130	130	180	180	180	130	130	180
Minimum Top speed pure electric	[km/h]	#	100	130	130	180	#	100	130	130	180
Total minimum driving range	[km]	500	500	500	120	500	500	500	500	200	500
Battery powered minimum driving range	[km]	#	20	80	120	#	#	20	80	200	#
Fuel consuming minimum driving range	[km]	500	480	420	#	500	500	480	420	#	500

Please note that the top-speed criterion for BEV and REEV is reduced in general to reflect the market in the 2010 timeframe. The driving range criterion for BEV is clearly reduced for 2010 compared to the other configurations, and higher but still clearly below 500km (all other configurations) for 2020+ due to restricted battery capacities. However, acceleration and gradeability criteria are identical for all other vehicles.

Powertrain configurations and components were selected accordingly. The vehicle configurations required to achieve these performance criteria are detailed in the **TTW report**.

With respect to regulated pollutant emissions, technologies (engine, powertrain and after-treatment) required to comply with emission regulations, i.e.

- EURO 5 for 2010 vehicles,
- EURO 6 for 2020+ vehicles

have been installed on the appropriate vehicle configurations and components were selected accordingly.

2.4.2 Vehicle simulations

All vehicle/powertrain configurations were simulated with a comprehensive simulation tool. For previous versions of the TTW/WTW study the ADVISOR modelling tool had been used. Several reasons led to a change of this approach and the AVL CRUISE system delivered the results for this version.

Both tools offer similar capabilities with respect to basic calculation of energy flows in a conventional vehicle and the operations that can be simulated. For both simulation tools, at least the following elements are common:

- Vehicle longitudinal dynamics physical model
- Basic vehicle and powertrain components' characteristics (engine, gearbox, final drive, wheels, chassis and use of required auxiliary energy consumers)
- Fuel consumption and pollutant emissions calculations were carried out using pre-existing 2-D engine maps.

Differences exist when it comes to modelling complex non-conventional vehicle architectures and powertrain control algorithms: AVL CRUISE offers detailed simulation options in terms of systems and components modelling. In view of the increased complexity and diversification of parameters characterizing identified vehicle configurations relevant today and – even more so – expected to be relevant at the 2020+ time horizon, the choice of AVL CRUISE is certainly robust.

Despite overall comparability of results produced by the two simulation tools used in the different versions of JEC TTW analysis, differences may be of specific relevance for some of the more complex vehicle configurations particularly when considering the performance of auxiliaries, as specified in *Sections 5 and 6* of the **TTW report** for the 2010 and 2020+ vehicle configurations.

Simulations were carried out for each neat fuel separately (gasoline, diesel, CNG, LPG and hydrogen). For alternatives to gasoline (ethanol, MTBE/ETBE) and diesel (bio-diesel, HVO, synthetic diesel, DME) it was assumed that, whether used neat or in blends, the fuel consumption on an energy basis would remain the same as for the base fuel. In other words these alternatives fuels were deemed not to have any effect positive or negative on the energy efficiency of the engine. The corresponding GHG emissions were then calculated from the compositional data.

The main vehicle simulation results delivered by AVL CRUISE for this study were:

- Fuel energy (MJ/km) necessary to perform the NEDC cycle
- Electric energy (MJ/km) from the vehicles battery necessary to perform the NEDC cycle or parts of it
- Carbon dioxide emitted during the cycle (g CO₂/km)
- Performance criteria data.

Total GHG emissions expressed in CO_{2eq} take into account N₂O and methane emissions, through estimates of their emissions, and using the appropriate IPCC factors (for details refer to the **TTW report**, *section 4.3.3*) and are applied in the WTW integration.

2.4.3 Reference driving cycle

The standard regulatory NEDC road driving cycle, as applied for measuring today's passenger car emissions and fuel consumption in Europe, was used for simulating the TTW emissions.

Figure 2.4.3 **Velocity profile of the reference NEDC driving cycle**

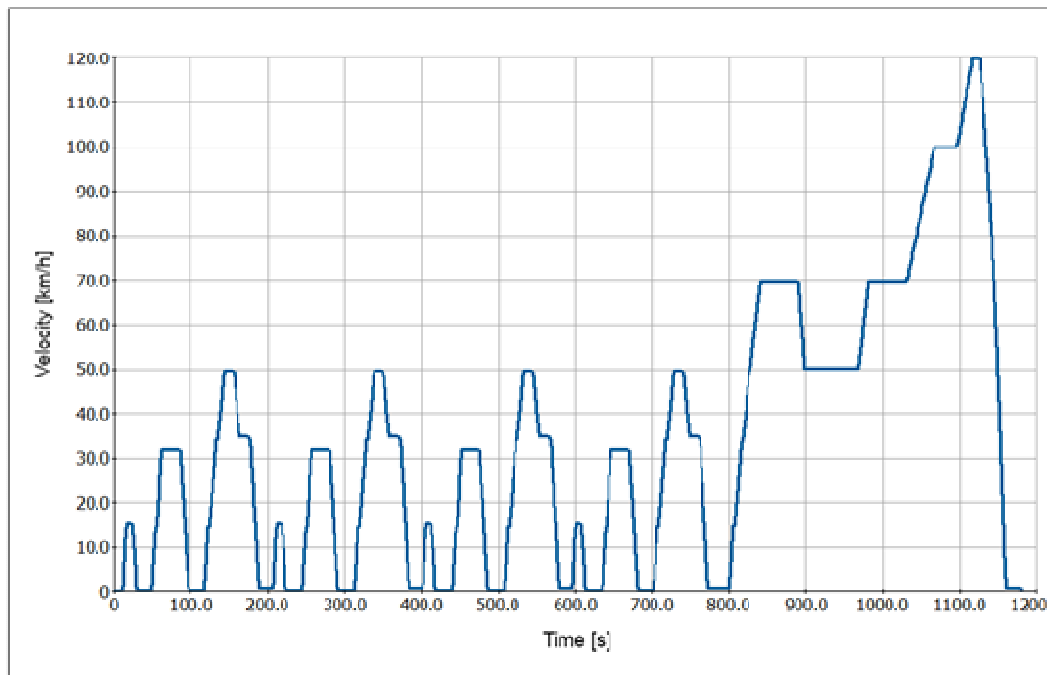

Cold start, as required by the standard certification tests, was included in the calculations. Gear changes for conventional vehicle configurations with manual transmission (MT5 or MT6) are defined by legislation, whereas gear changes for xEV vehicles with automatic transmission are chosen due to shifting strategies based on the specific xEV control.

Evaluation of PHEV & REEV

The European Legislation UN ECE R 101 (Rev 2) formulates specific rules for evaluating the fuel consumption of PHEVs/REEVs with intermittent ICE operation, which is based on the weighting of Charge Depleting (CD) and Charge Sustaining (CS) operation modes partial results (further details see ***TTW report, section 4.2***).

WLTP

It is expected, that by 2020+ the **World-wide harmonized Light vehicles Test Procedure (WLTP)** will be an obligation in terms of vehicle fuel consumption and emission testing, whether in parallel to or instead of the NEDC. However at the time of elaboration of this study the WLTP is still not clearly defined in all its details. Therefore, it was not used for the investigation in the current version of the TTW study.

Evaluation of results for the reference vehicle

The experimental data from the European manufacturers C-segment vehicles which were used to define the reference vehicle were used to cross-check the simulation results for 2010. This was done for the configurations with a PISI or DISI engine. Results were in close agreement: the simulated fuel consumption for the gasoline PISI / DISI was 6.5 / 6.3 l/100 km, which is close to the average manufacturer data of 6.6 / 6.1 l/100 km.

2.5 WTW integration

The results of the WTW integration are presented in the following sections. *Sections 3 to 5* introduce the fuels, the characteristics of the relevant vehicles and present the energy and GHG balances for the various pathways. *Section 6* briefly discusses the issue of optimum use of energy resources.

The WTW energy and GHG figures combine

- The WTT expended energy (i.e. excluding the energy content of the fuel itself) per unit energy content of the fuel (LHV basis),
- With the TTW energy consumed by the vehicle per unit of distance covered (on the NEDC cycle).

The energy figures are generally presented as total primary energy expended, regardless of its origin, to move the vehicle over 1 km on the NEDC cycle. These figures include both fossil and renewable energy. As such they describe the energy efficiency of the pathway.

Total WTW energy (MJ/100 km) = (MJ TTW energy / 100 km) • (1 + MJ WTT total expended energy / MJ fuel)

For fuels of renewable origin we have also evaluated the fossil energy expended in the pathway, illustrating the fossil energy saving potential of that pathway compared to conventional alternatives.

Fossil WTW energy (MJ_{fossil}/100 km) = (MJ TTW energy /100 km) • (λ + MJ WTT fossil expended energy / MJ fuel)

λ = 1 for fossil fuels, 0 for renewable fuels

GHG figures represent the total grams of CO₂ equivalent emitted in the process of delivering 1 km of vehicle motion on the NEDC cycle.

WTW GHG (g CO_{2eq}/km) = TTW GHG (g CO_{2eq}/km) + (MJ TTW energy /100 km)/100 • WTT GHG (g CO_{2eq}/ MJ fuel)

The uncertainty ranges from WTT and TTW have been combined as variances i.e. as the square root of the sum of squares.

Results for all pathways considered in the study are summarised in WTW Appendix 1.

2.6 Applicability to other vehicle configurations

Although the current WTW analysis is focused on passenger cars, some general conclusions can also be relevant to heavy duty trucks and possibly other vehicle configurations e.g. buses.

WTT data can be directly applied to any other engine and vehicle applications designed for the specific fuel for which the production and distribution has been evaluated by the WTT methodology. However the TTW data and the combined WTW results are specific to the simulated passenger car configurations and application to trucks cannot be done in a direct quantitative manner. The duty cycles for heavy duty are significantly different from the light duty cycle and so are in most cases the overall powertrain efficiencies.

A heavy duty WTW study would also need to include additional vehicle/fuel combinations, e.g. dual fuel concepts for CI with LNG or CNG as the main fuel. The powertrain combinations relating to hybrids, plug-in electric and fuel cells are not applicable to the heavy duty truck side. Hybrids and fuel cell pathways can have some relevance to city buses.

In a qualitative manner, and with regard to the general ranking of the different fuel pathways, the results from the conventional powertrain TTW simulations (ICE) are reasonably relevant also for heavy duty. It should be noted however that the absolute positions and spacing between the results in the figures of the following sections are likely to change significantly in some cases. Some care should also be taken in cases where the basic engine configuration and the way of using a particular fuel differ between light and heavy duty. That can be the case for instance for methane fuels (LNG, CNG in dual fuel concepts with CI combustion) and for DME which will be used as a single fuel in the heavy duty applications.

3 ICE based Vehicles and Fuels

3.1 Vehicles considered for 2010/2020+

The vehicles and powertrains already available today were simulated on the basis of available “real” 2010 data. Fuels, engine maps and vehicle characteristics, were precisely defined, constructed from a combination of existing and validated data. The 2010 conventional vehicle results are therefore considered as the starting reference for comparison.

Diversification of fuels and powertrains is expected from 2010 and beyond. For ICE based vehicles the 2020 options essentially represent advances in conventional technologies including hybrids.

Table 3.1-1 presents the fuel/vehicle configurations that have been considered for this study. All combinations have been analysed for the 2010 and 2020+ time frame.

Table 3.1-1 Simulated combinations and derived combinations due to fuel properties for ICE based vehicles and fuels.

Powertrain \ Fuel	PISI	DISI	DICI	Hybird DISI	Hybrid DICI
Gasoline	Blue	Blue		Blue	
Gasoline E10 (market blend)	Yellow	Yellow		Yellow	
Gasoline: E20 (high RON)	Blue	Blue		Blue	
Diesel					Blue
Diesel B7 (market blend)			Yellow		Yellow
LPG	Blue	Blue			
CNG	Blue	Blue			
E85	Blue	Blue		Blue	
MTBE	Yellow	Yellow		Yellow	
ETBE	Yellow	Yellow		Yellow	
FAME			Yellow		Yellow
DME			Yellow		Yellow
Syndiesel			Yellow		Yellow
HVO			Yellow		Yellow

All configurations modelled for both 2010 and 2020+ (except when stated otherwise)

Colour coding

- Modelled in detail with the vehicle simulation tool
- Derived from simulations using the relevant fuel

Table 3.1-2 shows some key data for the 2020+ ICE-based vehicles.

Table 3.1-2 Data for the 2020+ ICE based vehicle configurations.

"ICE based" Configurations 2020+	PISI			DISI			DICI		Hybrid DISI	Hybrid DICI	
	Gasoline ¹	LPG (mono-fuel)	CNG (mono-fuel)	Gasoline ¹	LPG (mono-fuel)	CNG (mono-fuel)	Diesel ²	DME (mono-fuel)	Gasoline ¹	Diesel ²	
Powertrain											
Displacement	L	1,4	1,44	1,6	1,2	1,23	1,32	1,6		1,0	1,6
No. of Cylinders	---	IL 4			IL 3			IL 4		IL 3	IL 4
Power	kW	76	78	77	85	87	87	84,8		70	85
ICE mass	kg	135	135	135	135	135	135	165	165	135	165
Transmission mass	kg	50	50	50	50	50	50	50	50	80	80
Powertrain mass change	kg	Reference	0	0	Reference	0	0	Reference	0	+30	+30
Storage System											
Fuel Tank Capacity	L	35	60 + 14	100 + 14	35	60 + 14	100 + 14	35	60 + 14	25	25
Tank System mass	kg	15	40	60	15	40	60	15	40	15	15
Fuel mass	kg	26	37	27	26	37	27	29	44	19	21
Storage System mass change	kg	Reference	+36	+46	Reference	+36	+46	Reference	+40	-7	-8
Electric Components											
e-Motor mass ³	kg									28	28
e-Motor power: peak/cont.	kW									24 / 12	
Battery mass ³	kg									26	26
Battery Maximum Power	kW									30	
Battery Energy (Total / Available)	kWh									1 / 0,4	
xEV wiring harness mass	kg									11	11
eComponents mass change	kg									+65	+65
Vehicle											
Curb weight (incl. driver, 90% fuel)	kg	1190	1226	1236	1200	1236	1246	1260	1300	1288	1347
Performance mass: Curb + 125kg	kg	1315	1351	1361	1325	1361	1371	1385	1425	1413	1472
Gross vehicle mass: Curb + 550kg	kg	1740	1776	1786	1750	1786	1796	1810	1850	1838	1897

1) Same vehicle is assumed for the different fuel variants Gasoline, Gasoline E10 market bl., Gasoline E20 High RON & E85.
2) Same vehicle is assumed for the different fuel variants Diesel, Diesel B7 market blend, FAME, FT-Diesel & HVO.
3) Masses for e-motor include housing, power electronics and cooling system.

3.1.1 Gasoline and Diesel vehicles

Fuel efficiency is expected to improve significantly over time. Achievable improvements were discussed and estimated among the EUCAR/ AVL team members on the basis of expected technological progress (e.g. friction reduction, engine control, combustion improvements, etc.). These inputs were then integrated using the AVL CRUISE model to give overall performance figures. The expected fuel consumption reductions for the various technologies are presented in the table below.

Table 3.1.1 2010 – 2020+ fuel efficiency improvements for conventional vehicles

Technology Walk for "ICE only" Powertrain Configurations (without consideration of other GHG)		PISI with Gasoline Fuel		DISI with Gasoline Fuel		DICI with Diesel Fuel	
		NEDC ¹ CO ₂ -Emissions	Technology dependent CO ₂ Reduction	NEDC ¹ CO ₂ -Emissions	Technology dependent CO ₂ Reduction	NEDC ¹ CO ₂ - Emissions	Technology dependent CO ₂ - Reduction
		g/km	%	g/km	%	g/km	%
"ICE only" Variant 2010		155,1	Reference	149,6	Reference	119,0	Reference
Transmission	Transmission Measures ²	148,2	4,4%	145,4	2,8%	114,2	4,0%
ICE	New ICE for 2020+	133,4	9,5%	125,6	13,2%	105,4	7,4%
	Improved Auxiliaries	129,8	2,3%	122,1	2,3%	102,2	2,7%
Start & Stop		122,4	4,8%	116,0	4,1%	98,0	3,5%
Vehicle Measures	Weight Reduction	118,7	2,3%	112,6	2,3%	94,6	2,8%
	Improved aerodynamics	113,9	3,1%	108,0	3,0%	90,4	3,5%
	Improved rolling resistance	110,2	2,4%	104,5	2,3%	86,8	3,0%
"ICE only" Variant 2020+		110,2	28,9%	104,5	30,1%	86,8	27,1%

1) NEDC Cycle results for cold start condition; Vehicle Test Mass = Curb weight incl. Driver, 90% fuel
2) For PISI: New 6-Speed Manual Transmission (MT5 is replaced); For DISI & DICI: Downspeeding & Improved Efficiency of 6-Speed Manual Transmission

For the conventional engines, the main contribution to fuel efficiency improvement comes from downsizing associated with supercharging. The benefits in improving the electrification of auxiliaries as e.g. steering and brake pumps or oil pumps, is contributing a ~2% fuel consumption benefit across the configurations.

A significant contribution to efficiency improvement is related to vehicle measures. Improvements in aerodynamics, rolling resistance and a weight reduction for the reference vehicle glider deliver ~7% fuel consumption reductions for the conventional vehicles in 2020+.

To comply with the EURO 6 regulations the Diesel configurations are equipped with an aftertreatment system consisting of a DPF and lean NOx trap (LNT).

3.1.2 Hybrid gasoline and hybrid diesel vehicles

For hybrids, the additional fuel economy is a function of the ‘hybrid control strategy’ and of the degree of electrification, i.e. the battery size and electric motor characteristics. The electric motor provides a high torque, available immediately upon start up and over a wide range of rotation speed. As a result, hybrid configurations deliver good acceleration performance, even though they tend to be heavier than conventional ones.

The hybrid configurations considered in the study are based on the following requirements:

- Capacity to start and run a few km on the battery only,
- Top speed achieved without electrical assistance,
- Acceleration criteria achieved without electric motor peak power (for safety reasons).

Within these constraints the vehicle parameters have been set in order to obtain the best compromise between fuel economy and vehicle performance. In 2020+ electrification is not just seen as an add-on technology like in 2010, but as an integrated system design approach, where the ICE is optimized together with the electric motor (used for propulsion) in terms of combined system performance. Accordingly in case of the hybrid gasoline vehicles the ICEs are downsized and downrated (reduced in their maximum power), operate with a Miller cycle with increased compression rate. Hybrid Diesel ICEs are not downsized nor downrated to prevent complex NOx after-treatment systems.

Hybrid configurations will benefit from all of the improvements applicable to conventional configurations for 2020+. In addition, it was considered that the hybrid architecture would allow further improvements compared to the 2010 efficiencies, as shown in the following table.

Table 3.1.2 2010 – 2020+ Fuel efficiency improvements for hybrids

Technology Walk for HEV Powertrain Configurations (without consideration of other GHG)		Hybrid DISI with Gasoline Fuel		Hybrid DICI with Diesel Fuel	
		NEDC ¹ CO ₂ -Emissions	Technology dependent CO ₂ Reduction	NEDC ¹ CO ₂ -Emissions	Technology dependent CO ₂ Reduction
		g/km	%	g/km	%
Hybrid Variant 2010		104,9	Reference	94,4	Reference
Transmission	New 8-Gear Automatic Transmission	98,6	6,0%	88,5	6,3%
ICE	New ICE ²	86,5	11,5%	80,9	8,1%
Electric Motor	New 24 kW Brushless Permanent Magnet EM	84,4	2,0%	78,4	2,6%
Battery	New 1.0 kWh High Power Density Li-Ion Battery	84,0	0,4%	78,2	0,2%
Auxiliaries	Improved Auxiliaries	81,9	2,0%	76,3	2,0%
Vehicle	Improved vehicle weight, aereodynamics & rolling resistance	69,0	12,3%	64,5	12,5%
Hybrid Variant 2020+		69,0	34,2%	64,5	31,7%

1) NEDC Cycle results for cold start condition; Vehicle Test Mass = Curb weight incl. Driver, 90% fuel
2) For Hybrid DISI new 70 kW ICE; For Hybrid DICI new 85 kW ICE

3.1.3 Methane fuel vehicles (CNG, CBG, SNG)

Methane fuel vehicles (basically as CNG versions) have been in use for many years in Europe and in the rest of the world. The limited refuelling infrastructure and the additional cost of the equipment required for the vehicle have so far limited their development to fleet vehicles or geographic niches, generally supported by a favourable tax regime for the fuel and/or the vehicles.

Mono-Fuel adapted vehicle

In order to represent the real commercial options existing in 2010, a mono-fuel (NG and gasoline; the gasoline system for emergency or cold start only) vehicle was simulated. In such a vehicle, an additional CNG fuel system is fitted to the original gasoline engine. An additional CNG tank is also added, while the gasoline tank capacity is reduced (see **Table 3.1-2**).

2020+ improvements expected from NG vehicles

Being spark ignited, NG engines are expected to enjoy the same fuel efficiency improvement as their gasoline homologues through downsizing, turbo-charging, use of Miller cycle and increased compression. The measures taken for conventional vehicles towards fuel efficiency are also applicable to methane propelled vehicles.

3.1.4 LPG vehicles

The LPG vehicle configurations in this study are mono-fuel (LPG/gasoline) PISI and DISI versions (see **Table 3.1-2** for the 2020+ vehicle characteristics). As a result the only major change to the baseline gasoline vehicles are the addition of an LPG tank and the reduction of the gasoline tank size (towards 14L) resulting in a small vehicle mass increase. Also we assumed liquid injection so that the torque characteristics and the associated acceleration performance remained the same.

3.2 Conventional gasoline and diesel fuel

3.2.1 Gasoline and Diesel production

Conventional road fuels are widely expected to provide the bulk of road transportation needs for many years to come and certainly within the time horizon of this study. Consequently, ICE engines fuelled by gasoline or diesel fuel from crude oil represent the reference against which all the alternatives were assessed.

The energy and GHG savings related to the replacement of gasoline and diesel by alternative fuels corresponds, therefore, to marginal production of up to 10-15% of the total road fuels demand. Over the study time period, non-conventional crude sources are not expected to impact the European market and Middle East crude remains the appropriate marginal energy supply (see **WTT report**, section 3.1).

3.2.2 Energy and GHG balance

The aggregated WTT and TTW energy and GHG figures for the 2020+ and 2010 vehicles (including hybrids) are shown in **Figure 3.2.2-1**. The WTT energy and GHG figures for conventional fuels are relatively low, so that the ranking of the different options is overwhelmingly determined by the performance of the powertrain.

As a result of the relative imbalance between gasoline and diesel fuel demand in Europe, the production of marginal diesel fuel is more energy-intensive than that of gasoline. On a WTW basis the impact is modest and more than compensated for by the superior efficiency of the Diesel CIDI engine compared to the gasoline PISI. Over the NEDC cycle, the gasoline DISI engine has lower fuel consumption than the PISI, due to its capacity to run in lean-burn mode.

The 2020+ figures result from the relative fuel efficiency improvements indicated in **Table 3.1-1**. By then, performance of gasoline PISI and DISI are predicted to come much closer together, PISI technologies taking a higher benefit from downsizing /turbo-charging applications.

Figure 3.2.2-1a/b WTW total expended energy and GHG emissions for conventional fuels (ICE and hybrid vehicles)

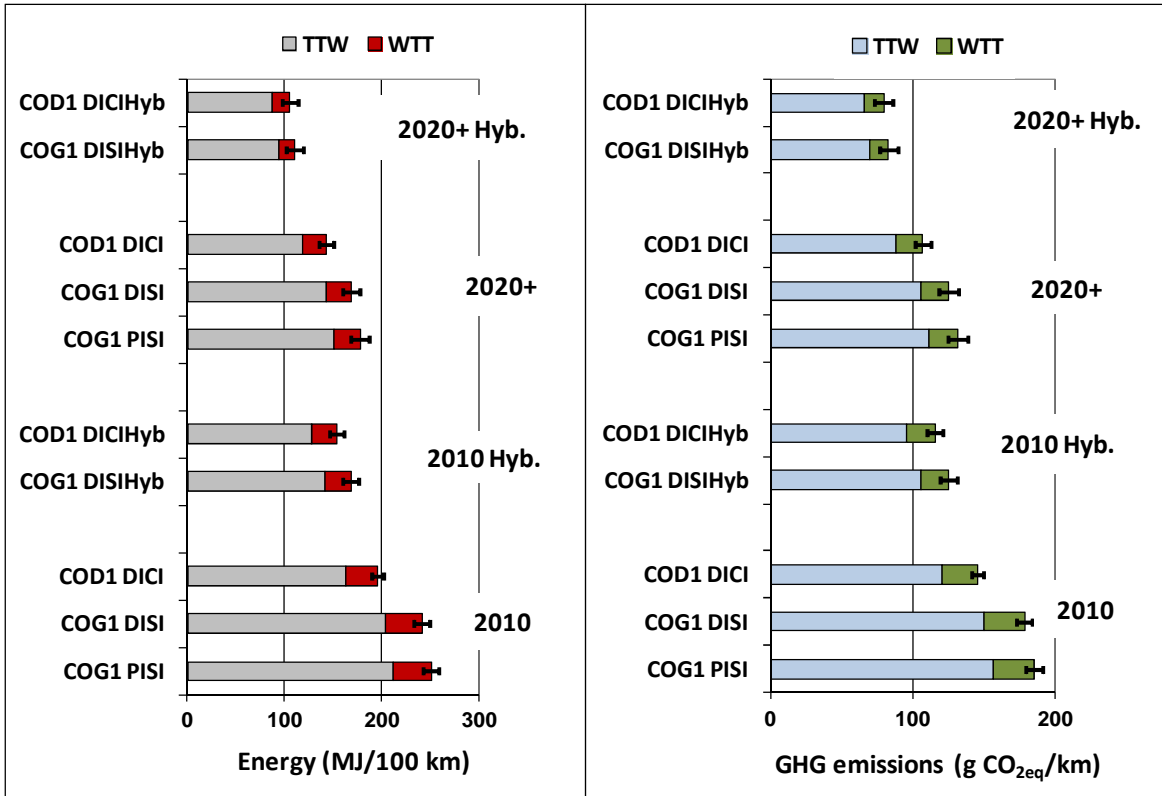

Key to pathway codes

COG1	Conventional gasoline
COD1	Conventional diesel fuel

Figure 3.2.2-2 WTW energy expended and GHG emissions for conventional fuels ICE and hybrid vehicles

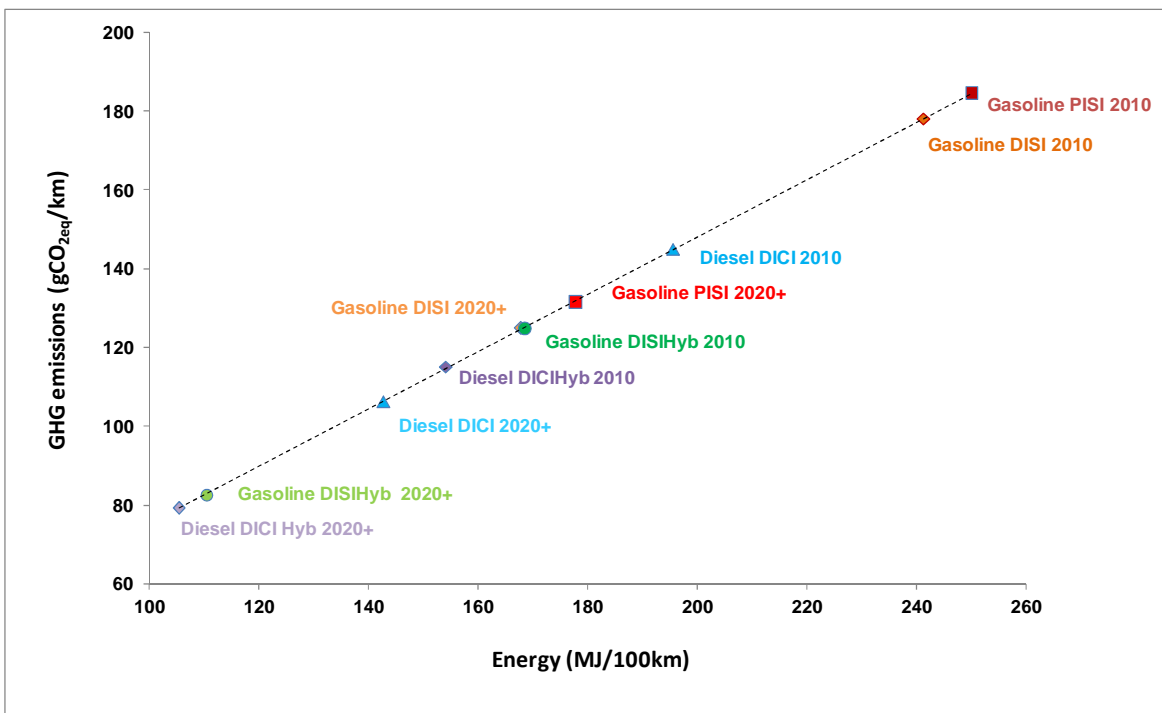

Figure 3.2.2-2 clearly illustrates the potential for improvement of conventional fuels and ICE based vehicles.

- *The efficiency gap between SI and CI vehicles is narrowing, especially for hybrid versions*

The hybridization option investigated brings an additional energy and GHG reduction of about 30% for gasoline and 20% for diesel hybrid vehicles. Further optimisation of hybrid configurations may bring additional savings in the future.

- *Developments in engine efficiency and vehicle technology options including hybrids will continue to contribute to CO₂ emissions reductions through reduced fuel consumption*

3.3 Methane (CNG, CBG, SNG) and LPG fuels

3.3.1 CNG production and availability

Natural gas sourcing

Natural gas is widely available in Europe, distributed through a dense network of pipelines to industrial, commercial and domestic consumers. The European production (mainly from the UK, the Netherlands and Norway) is complemented by sizeable imports from Algeria and mainly Russia. Demand is expected to grow strongly mainly to feed the increasing demand for electricity, particularly in view of the coal and nuclear phase-out in some countries.

World natural gas reserves are very large but European production is set to decline during the coming decade so that the share of imports as part of European supply will steadily increase. Russia, other countries of the FSU and the Middle East are the most credible long-term major supply sources for Europe.

Additional natural gas for road transport would have to be sourced from marginal supplies. We have considered four sourcing scenarios:

- 7000 km pipeline (typically from western Siberia),
- 4000 km pipeline (typically from south-west Asia),
- Shale gas extraction within Europe,
- LNG shipping over a distance of about 10,000 km (typically the Middle East¹).

Beside the shale gas pathway these future marginal gas supplies to Europe are far away and the associated transport energy represents an important fraction of the total energy and GHG balance of CNG.

On the other hand volumes that can reasonably be expected to find their way into road fuels within the timeframe of this study would only represent a small fraction of the total European natural gas consumption (a 5% share of the 2020 European road fuels market would represent about 2.5% extra gas demand) and would not require extensive addition to the gas distribution network (but will of course require refuelling equipment).

Distribution and refuelling infrastructure

Like all gaseous fuels, CNG requires a dedicated infrastructure for distribution and refuelling. The natural gas grid, developed in most areas of Europe to serve domestic, commercial and industrial customers can be used for supplying natural gas to refuelling stations. For a road fuel market penetration up to the 10% mark, it is generally accepted that sufficient capacity would be available in the existing grid. Some areas of Europe are not served by the grid and it is unlikely that transport demand alone would justify extensive additions to the existing networks. For such areas LNG, distributed by road and vaporised at the refuelling station, may be an option.

Infrastructure issues and costs are essentially related to refuelling stations. Assuming the existing conventional fuels sites are used, the investment and operating costs would be mostly associated with storage, compression and refuelling hardware. The safety issues related to the widespread use of a flammable gas at high pressure are real but well understood for CNG and not considered as a significant barrier to introduction.

¹ Shipping distance between the Arabian gulf and Western European ports via the Suez canal

3.3.2 Biogas (CBG) production

The anaerobic fermentation of organic matter produces a gaseous mixture, known as "biogas", consisting mainly of methane and CO₂. A suitable feedstock is biomass containing components such as carbohydrates (i.e. saccharides such as glucose), fatty acids and proteins. Anaerobic decomposition and formation of methane commonly occurs when manure, crop residues or municipal waste are stockpiled or used as landfill, or when organic matter is immersed in water as occurs naturally in swamps, or is applied with liquid manure.

Although most biogas production installations have so far been on a relatively small scale and geared to production of heat and power, concepts for larger plants have been developing with a view to produce a gas that can be used in combination with or as an alternative to natural gas as automotive fuel (Compressed Bio-Gas or CBG). This requires cleaning and upgrading of the gas to remove various impurities and the bulk of the CO₂. Some such plants already exist in Scandinavia.

We have considered four cases for upgraded biogas production. Two cases use waste material namely from municipal organic waste and manure. In the other two cases it is assumed that farmed crops are used, namely fodder maize (as the whole plant) and a combination of fodder maize and barley produced on the same land in a double cropping system. In all cases we have assumed that the upgraded gas joins an existing gas grid to reach the refuelling station.

The waste material used a feedstock is considered to be "GHG-free". Dedicated crops do carry a modest GHG footprint from farming activities (fossil carbon and N₂O emissions). In the production process, part of the biogas is used to fuel the process. As a result biogas has a generally favourable fossil energy and GHG emissions footprint. The GHG footprint can, however, be adversely affected if the residue after digestion (the "digestate") is stored in the open air as it continues to produce methane. Closed digestate storage (and methane recovery) is therefore good practice. The total energy is relatively high but this is not very relevant for a process fuelled with a waste material that has no other uses. The overall GHG footprint is somewhat higher when dedicated crops are used. Biogas production occurs naturally with manure. Methane emissions can therefore be avoided by using that manure for dedicated biogas production. Note that the large resulting credit is the result of intensive livestock rearing rather than an intrinsic quality of biogas.

3.3.3 Synthetic natural gas (SNG) from (renewable) electricity

It is in principle possible to produce methane from electric power. The route involves producing hydrogen via electrolysis, then synthesizing methanol from hydrogen and CO₂ and finally turning methanol into methane. This could be an option for using e.g. off-peak wind electricity while CO₂ could be recovered from e.g. the flue gases from a fossil fuel power station.

3.3.4 LPG production and distribution

Liquefied Petroleum Gas (LPG) is a well-established niche automotive fuel in a number of EU countries. Although a large amount is produced by refineries, this production is entirely spoken for by existing markets such as domestic heating and cooking, various industrial applications and petrochemical feedstock. Indeed a large fraction of the LPG used in Europe today is imported, mostly originating from associated gases and liquids in crude oil and mainly natural gas production. The net effect of an increase in the use of LPG for automotive purposes would be to increase imports. Regardless of the physical source of supply, it is therefore the energy and GHG footprint of imported LPG that must be considered to gauge the impact on EU energy cost and global CO₂ emissions. We have therefore opted to represent the marginal case of LPG import into Europe from remote gas fields (Middle East).

3.3.5 Energy and GHG balance

CNG pathways energy and GHG balance

In this version of the study we have modelled a mono-fuel CNG vehicle for both 2010 and 2020+ (see section 3.1.3). Because of lower volumetric efficiency with a gaseous fuel and the higher fuel tank weight, a slightly larger engine displacement was needed in the CNG vehicle to match the performance criteria. The fuel economy performance of the CNG vehicles compared to conventional ones is illustrated in **Figure 3.3.5-1** which also shows the expected improvement between 2010 and the 2020+ horizon.

Figure 3.3.5-1 *TTW fuel consumption for conventional and CNG vehicles*

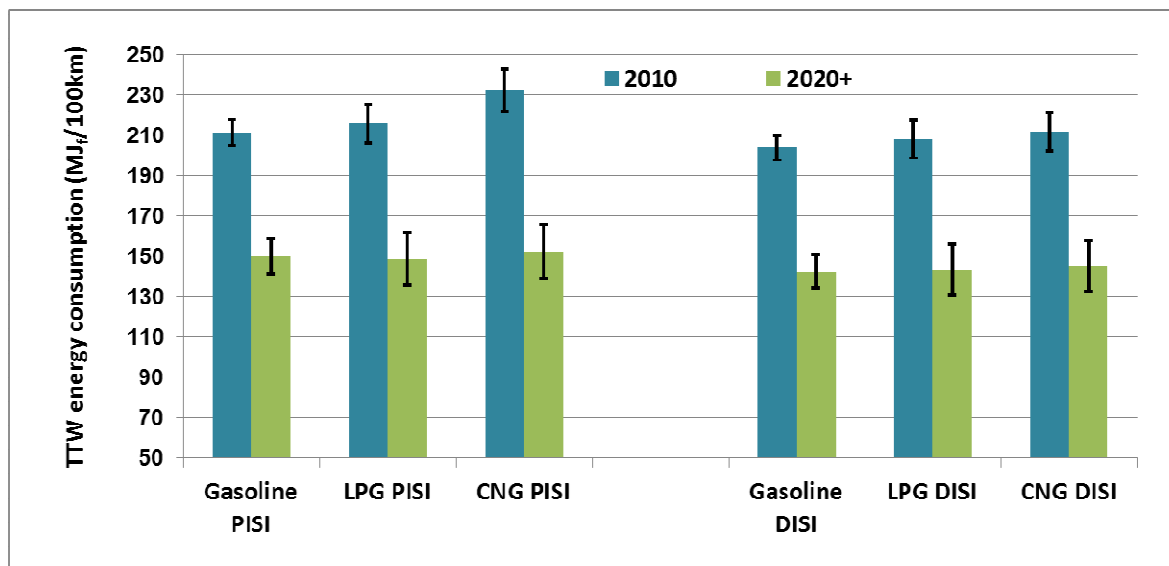

CNG vehicles are currently slightly less efficient than equivalent gasoline vehicles while diesel vehicles enjoy a net advantage. In the future, however, improvements in spark ignition engines will bring all technologies much closer together.

Figure 3.3.5-2 shows the WTW figures, combining the impacts of vehicle technology and of the gas production route, particularly transport distance. The option of piped gas over 7000km comes close to LNG and we have therefore not included it in these graphs for clarity. Shale gas, assumed to be extracted within Europe, has a slight advantage over other options mostly due to proximity to the customer. The higher hydrogen to carbon ratio gives natural gas an advantage over crude-based fuels in GHG terms but, on a WTW basis, this is compensated for extra energy requirement for fuel provision and somewhat lower vehicle fuel efficiency.

Figure 3.3.5-2a/b WTW total expended energy expended and GHG emissions for conventional and CNG pathways (PISI & DISI vehicles)

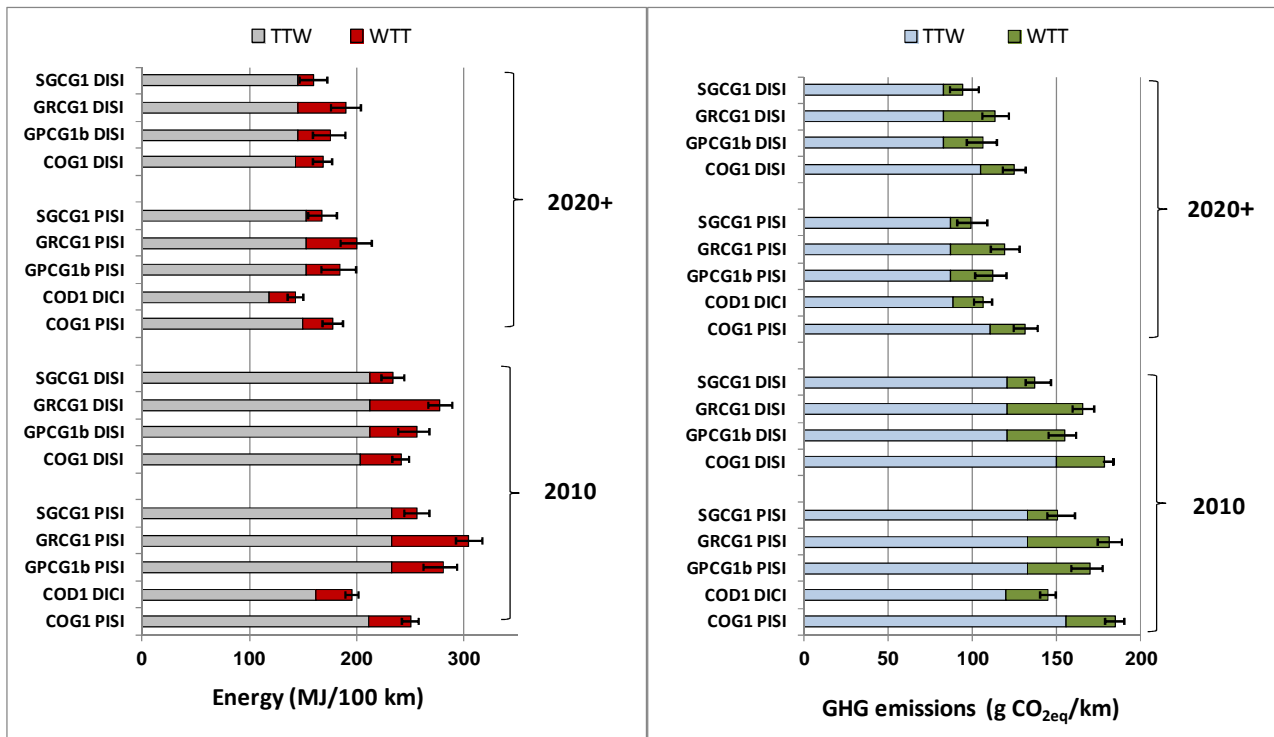

Key to pathway codes

COG1	Conventional gasoline
COD1	Conventional diesel fuel
GPCG1b	CNG from imported NG 4000 km
GRCG1	CNG from remote LNG, vap at import terminal
SGCG1	Shale gas (EU)

- *Currently, the WTW GHG emissions for CNG lie between gasoline and diesel,.*

- *Beyond 2020+, greater engine efficiency gains are predicted for CNG vehicles:*
 - *WTW GHG emissions approaching those of diesel.*
 - *WTW energy use remains slightly higher than for gasoline.*

The gas transport distance and route is critical to the overall balance. The 4000km pipeline route is considered as a reasonable representation of Europe's marginal supply for a number of years to come. Longer term, a larger share of LNG and possibly also longer pipeline routes can be expected. Pipeline technology is evolving and higher operating pressures are nowadays possible. This may result in new pipelines consuming less transport energy although other considerations such as initial pipeline costs, may limit this effect (see more details in **WTT report**, section 3.2.3).

- *The origin of the natural gas and the supply pathway are critical to the overall WTW energy and GHG balance.*

Biogas (CBG) and Synthetic methane pathways energy and GHG balance

The CBG and SNG WTW energy and GHG emissions balances are shown on the following figure, compared to the conventional and selected CNG figures.

Figure 3.3.5-3a/b WTW energy expended and GHG emissions for biogas and synthetic methane (as compressed gas) (2020+ PISI vehicle)

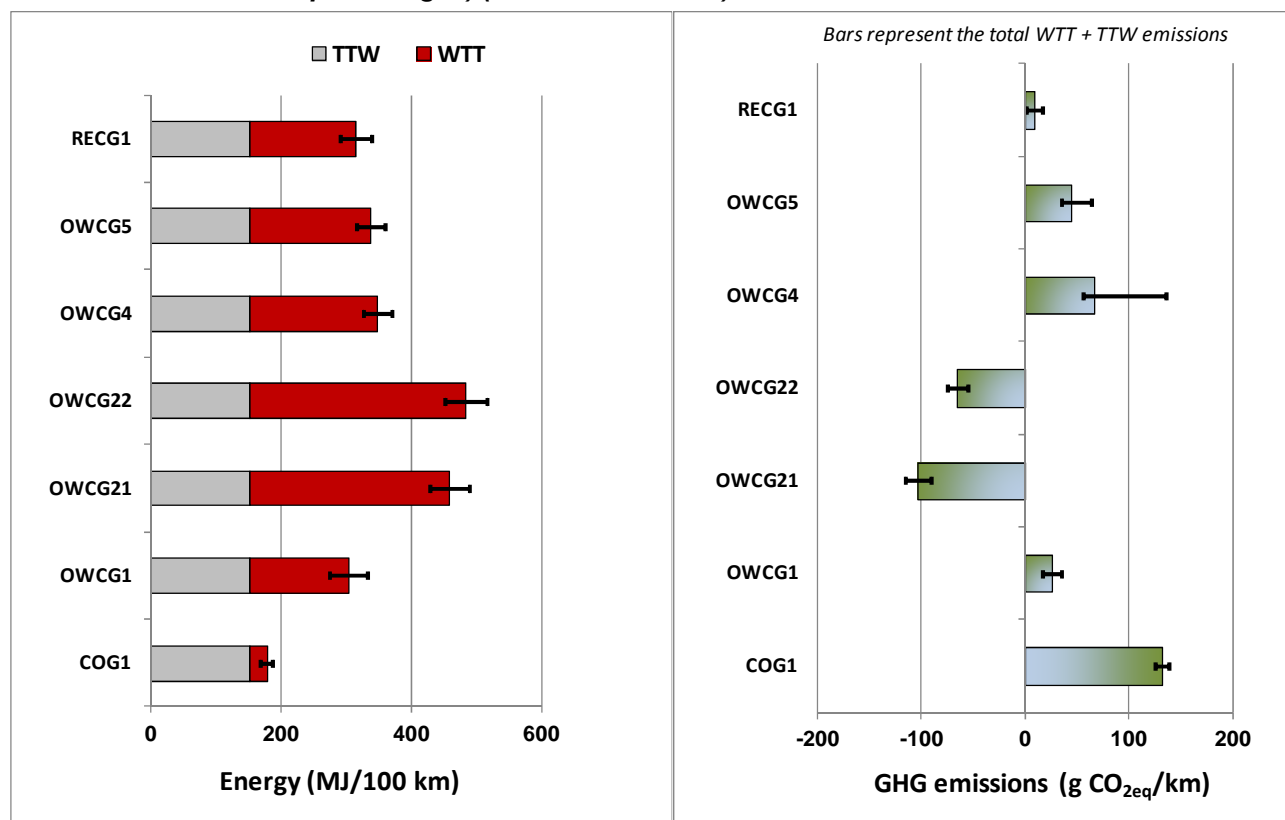

Key to pathway codes

COG1	Conventional gasoline
OWCG1	Municipal waste (closed digestate)
OWCG21	Manure (closed digestate)
OWCG22	Manure (open digestate)
OWCG4	Maize, whole plant (closed digestate)
OWCG5	Double cropping (closed digestate)
RECG1	Syn-methane from renewable electricity

Although the overall energy input for production of biogas and synthetic methane is high, much of this energy is of renewable origin and so the GHG emissions can be very low, especially if biomass from waste is used for biogas. As shown in the *WTT Report*, Section 4.8.2.3, similarly low GHG emissions are achieved when biogas is used to generate electricity.

With regard to synthetic methane the reader is also referred to section 6 where the different uses of renewable electricity are discussed.

- Producing and using biogas, particularly from waste materials, or synthetic methane from renewable electricity has a very low GHG impact.

- However, synthetic methane may not be the best option to use renewable electricity (see section 6).

LPG pathways energy and GHG balance

The LPG WTW energy and GHG emissions balances are shown on the following figure, compared to the conventional and selected CNG figures. LPG's GHG emissions lie between diesel and CNG and energy

between gasoline and diesel. Although not explicitly shown in the graph, transport distance has a significant impact, representing about 25% of the WTT energy in this case

Figure 3.3.5-4a/b WTW total expended energy expended and GHG emissions for LPG (2020+ PISI & DISI vehicles)

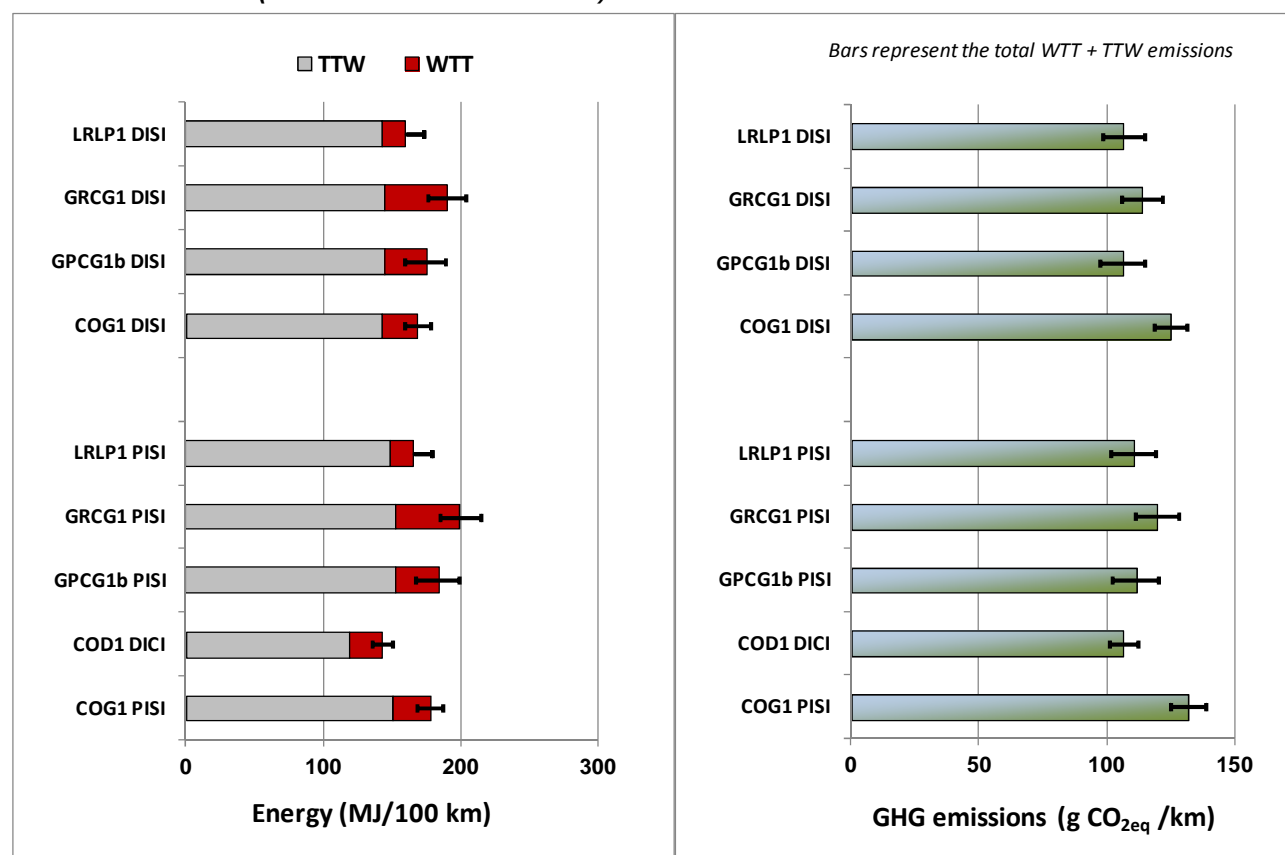

Key to pathway codes

COG1	Conventional gasoline
COD1	Conventional diesel fuel
GPCG1b	CNG from imported NG 4000 km
GRCG1	CNG from remote LNG, vap at import terminal
LRLP1	LPG imported from remote gas field

3.4 Alternative liquid fuels / components

This section deals with all the non-conventional liquid fuels produced in a variety of ways and which can be used either neat or in blends with conventional gasoline or diesel fuel. We have considered ethanol, bio-diesel and synthetic diesel fuel. For completeness we have also added ETBE, as an alternative way of using ethanol and MTBE for reference. Such fuels share three advantages over gaseous fuels:

Infrastructure

If used in blends with conventional fuels, these fuels do not require any special distribution infrastructure except what is necessary to transport them to existing refineries or fuel depots. If used neat, the required infrastructure is more extensive but still much simpler than what would be required for gaseous fuels.

Vehicles

Generally these fuels can be used in existing vehicles with little or no modification as long as they are in small percentage blends with conventional fuels. For high percentage blends or neat fuels specially adapted vehicles may be required although changes are much less drastic than for gaseous fuels.

Flexible usage

Being miscible with conventional fuels they can be used in various proportions in relation to their availability in a certain area and at a certain time, of course within the limits imposed by the vehicle population and /or the regulations in place.

The special case of DME

Di-Methyl-Ether or DME does not share the above advantages but is also discussed in this section as it falls into the category of direct substitute for diesel fuel and can be produced in a very similar way to synthetic diesel fuel. DME is gaseous at ambient conditions but can be liquefied under moderate pressure. Its use would require a dedicated distribution infrastructure very similar to that of LPG as well as specially adapted vehicles (fuel storage and injection system).

Effect on engine efficiency

Generally these fuels have not demonstrated any material effect on the intrinsic efficiency of the engines. There are various claims in the literature that certain fuels such as ethanol or synthetic diesel may increase energy efficiency. We considered that, at least at this stage, such claims have been neither proven in practice nor scientifically explained and have assumed engine efficiency to be constant.

One exception is ethanol used in higher concentrations, where engines can be adapted to take advantage of the higher octane to increase efficiency. This is the case for both E20 and E85 and this has been reflected in higher efficiency figures for both fuels.

- *A number of routes are available to produce alternative liquid fuels that can be used in blends with conventional fuels and, in some cases, neat, in the existing infrastructure and vehicles*

In the WTT part of this study we have also included a number of pathways to produce methanol. The latter is not, however, envisaged as a practical fuel for road vehicles at this stage.

3.4.1 Ethanol, Biodiesel (FAME/FAEE), and HVO

Ethanol is a well-established substitute for gasoline in spark-ignition engines. It can be produced from a variety of crops and other biomass resources. It has been used for many years in several parts of the world, occasionally neat, but more often in various blending ratios with conventional gasoline. Where high ethanol blends (e.g. E85) are used, they can only be used in vehicles specially adapted to use such fuels. However, engines can be developed and tuned for conventional gasoline containing small amounts of ethanol without adverse short or long term effects. The European EN228 specification for gasoline allows blending of ethanol up to 10%.

Bio-diesel is produced by reacting a vegetable oil with an alcohol, usually methanol, to give a so-called Fatty Acid Methyl Ester (FAME). This process splits the tri-glyceride molecule, separating glycerine as a co-product and producing a fuel which boils at around 350°C and is a suitable diesel fuel. Pure vegetable oil is very viscous as well as unstable, and consequently unsuitable as a component in road diesel fuel. Bio-diesel can be used without problems in standard diesel engines in blends up to 7% with conventional diesel fuel. Such blends are allowed by the EN590 diesel fuel specification

Although this has not been done in practice as yet, methanol can be substituted by ethanol to produce an Ethyl Ester (FAEE). Assuming ethanol is from bio-origin, this has the advantage of boosting the "renewability" of the fuel. FAEE pathways have been included in this version of the study.

3.4.1.1 Sources and manufacturing processes of ethanol

Ethanol is traditionally produced by fermentation of sugars. Virtually any source of carbohydrates can be used. Sugars are readily converted whereas heavier compounds such as hemicellulose first need to be broken down in a hydrolysis step. For historical, economic and practical reasons, the main crops used for the industrial production of ethanol are sugar cane (in tropical climates), corn (maize, mostly in the USA), sugar beet (mostly in Europe) and, more recently, cereals. The last two are currently, and for the foreseeable future the main potential sources of ethanol in Europe. Large scale ethanol production in Europe would rely mostly on wheat

although other cereals could be used. For completeness we have included pathways representing corn in the USA and in EU (maize), a mixture of barley and rye in EU and sugar cane in Brazil.

The fermentation process produces alcohol at a fairly low concentration in the water substrate. Purification of the ethanol by distillation is energy-intensive.

In recent years there has been a lot of interest in processes to convert cellulose into ethanol via separation and breakdown of the cellulose into fermentable sugars. Such routes potentially make a much wider range of crops available including woody biomass in all shapes or forms as well as crop co-products such as wheat straw or sugar beet pulp.

Amongst the vast number of possible options, we have elected to represent those that are the most relevant to Europe i.e. ethanol from sugar beet, wheat and woody biomass. We have also included a pathway representing state-of-the-art production of ethanol from sugar cane in Brazil.

The basic processes for producing ethanol from sugar beet or wheat are well-established. One possible point of discussion is the energy associated with distillation. There have been significant advances in this respect and we have used data representing state-of-the-art plants. There are two essential elements that determine the final energy and GHG balances:

- The way the energy required for the production process is generated,
- The way the co-products are used.

One important point to remember is that producers are likely to use energy and dispose of co-products in the most economical way, which is not necessarily the way that would maximise fossil energy saving and GHG avoidance. We have tried to represent the options that are most likely to “make sense” in practice but have also shown how currently less economic alternatives could alter the picture.

Sugar beet

We considered three options for utilising the pulp leftover after filtration of the diluted ethanol liquor and the so-called “slops”, another, smaller volume, co-product:

- Pulp used as animal feed, slops not used
- Pulp used as animal feed, slops used to generate biogas internally
- Pulp as a fuel for electricity production and slops used to generate biogas internally

Wheat and other cereals

Based on work done within the framework of the Low Carbon Vehicle Partnership in the UK, we have used the example of ethanol from wheat grain to illustrate the large impact of the process energy generation scheme on the overall energy and GHG balance. We have considered four options:

In the most basic (and low-capital) scheme, representative of many early facilities (in Europe and elsewhere), a simple, usually gas-fired, boiler provides the steam while electricity is taken from the grid. Because heat is required at low temperature, ethanol plants offer, however, good opportunities for combined heat and power (CHP) schemes. Combining this with a natural gas fired gas turbine results in a very energy-efficient if more capital-intensive process. In areas where coal or lignite is cheap and abundantly available, a simpler CHP scheme based on a coal-fired steam boiler combined with a backpressure steam turbine can also be envisaged. Finally surplus straw from the wheat itself can in principle be used as fuel through a similar CHP scheme. If this is likely to be a winner in terms of GHG emissions, this is also an expensive and largely untested scheme to put on the ground and to operate.

Wheat grain processing leaves a protein-rich residue known as “distiller’s dried grain with solubles” or DDGS which is traditionally used as animal feed because of its high protein content. DDGS has a high energy content and, after drying, could conceivably be used for energy generation e.g. through co-firing in a coal-fired power station. Specific data has been used for US corn.

Woody biomass and straw

The possibility of extending the range of feedstocks available for ethanol production from sugars and starch to cellulose is very attractive and a lot of research is being devoted to developing such routes.

Apart from the IOGEN straw conversion process (see below), we have represented all ligno-cellulose to ethanol routes under the single label of "wood". Accordingly, the underlying data represent a range of processes described in the literature although it must be realised that these processes have yet to be proven on the commercial scale. In such schemes the biomass input of the conversion plant includes non-cellulose material (e.g. the lignin of the wood) which is best used as an energy source. As the conversion energy represents most of the total energy requirement of the complete pathway, these pathways use very little external (fossil) energy.

As a separate option we have considered straw as a feedstock for ethanol production through the process promoted by IOGEN. The conversion process is similar to the wood to ethanol process although the IOGEN data suggests higher efficiency than other sources.

3.4.1.2 Sources and manufacturing processes of bio-diesel (FAME/FAEE)

In Europe the main crops are rape (also known as colza) in the centre and north and, of less importance, sunflower in the south. Waste cooking oils are also used to a limited extent. Soy oil is the main crop in the Americas (mostly USA, Brazil and Argentina) while palm oil is produced in large quantities in South East Asia (Indonesia and Malaysia).

Food grade vegetable oils have been in production for centuries. The additional trans-esterification process is also well-established. The traditional alcohol used is methanol although (bio-) ethanol can also be used. Oils from the crops mentioned above are all suitable for trans-esterification although bio-diesel from some oils (e.g. palm oil ester that has a high cloud point) need to be blended with others. There are a number of co-products the most important being the residue after pressing (or cake which leads to a commercial product known as meal) and glycerine produced during the trans-esterification step.

Meal is a protein-rich material mostly used today as animal feed. An alternative would be to use it as an energy source, the most likely route being biogas production.

Glycerine itself is used in many food and cosmetics applications but the market is limited. It is most likely to be sold as a substitute for alcohol and glycols in the manufacturing of e.g. paints, resins and antifreeze or to be used as animal feed. Such markets may not always be readily available and a good alternative would be to produce biogas or even hydrogen.

We have represented all co-product options for rape seed methyl ester. For rape seed ethyl ester and sunflower we have only shown the pathway corresponding to meal as animal feed and glycerine to internal biogas.

Soy bean biodiesel is a particularly tricky pathway to treat using the substitution methodology, because of the high proportion of soy meal co-product compared to the oil. Assumptions as to the fate of the meal are therefore paramount when it comes to the net footprint of the oil. The choice of substitution for soy meal is also difficult because soy meal is itself the main "swing-provider" of protein in animal feed. Agricultural practices such as "no till" can also play a significant role. We have represented three cases:

- No till agriculture, oil production at source (Americas) and import into EU
- No till agriculture, soy beans import into EU
- Conventional agriculture, oil production at source (South America) and import into EU

Soy meal is assumed to be used as animal feed, substituting American corn or EU wheat. Glycerine is assumed to be used to produce internal biogas.

Palm oil is always produced at source. The process involves production of liquid organic waste material the anaerobic digestion of which generates large amounts of methane. From a GHG emissions point of view, an important issue is whether this methane is recovered and used or simply emitted to the atmosphere. The process also generates surplus heat that may be put to use in some cases.

In this study we have assumed that the methanol used in production of FAME comes from fossil sources, in line with the prevailing production practice. Additional fossil energy and GHG emission benefits would accrue in the case that methanol from renewable sources were substituted.

3.4.1.3 Hydrotreated Vegetable Oil (HVO)

The amount of FAME that can be added to conventional EN590 diesel fuel is limited to maintain acceptable fuel quality and compatibility with the vehicles in the market. In addition, the trans-esterification process leaves the basic hydrocarbon chain of the molecule unchanged, so the fuel properties depend to some extent on the type of oil or fat used in the process. Where the oil or fat contains many double bonds, stability may be a problem and conversely if the chains are long and saturated it may be difficult to meet cold flow requirements.

As an alternative to trans-esterification the pure oil can be hydrotreated. This removes double bonds and oxygen from the molecule, yielding a paraffinic fuel similar in properties to Fischer-Tropsch diesel (see section 3.4.3). This has all the advantages of such fuels, can either be used alone or blended with conventional diesel, and the final fuel properties are virtually independent of the original feedstock, so a wider range of feedstocks can be used.

The Neste Oil process (NexBTL[®]) was the first to be used in commercial production, and we have modelled this process using rapeseed, soy and palm oils. Similar processes are being developed by a number of other companies, and for comparison a process from UOP has been included, using rapeseed oil.

3.4.1.4 N₂O emissions from agriculture

The routes described above rely on traditional "food" crops, typically produced through intensive farming which is responsible for a large portion of the GHG emissions from these pathways in large part because of nitrous oxide (N₂O) emissions. Although N₂O emissions are not very large in absolute terms, the very high greenhouse effect of this gas (about 300 times as much as CO₂ on a mass basis) makes them very significant.

There are essentially two sources: nitrogen fertilizer production and emissions of nitrous oxide from the field. The latter are by far the most uncertain and can vary by at least three orders of magnitude depending on a complex combination of soil composition, climate, crop and farming practices.

LCA or WTT studies of biofuels have estimated field N₂O emissions either from measurements on individual fields, or from calculations based on the so-called "tier 1" in the IPCC guidelines. The resulting error margins, if considered, can be very large so that it can be impossible to say for certain whether any pathway has a positive or negative GHG balance.

In version 3 of this study we applied a "tier 3" approach for Europe, i.e. we used a soils chemistry model. Unfortunately, the same approach was impossible for crops grown outside EU because there were not enough input data available; in these cases we were obliged to fall back on IPCC tier 1.

In this version we use an IPCC "tier 2" approach, because it requires less detailed input data than tier 3, and could thus be applied equally to crops grown both inside and outside EU. The new methodology was developed by the Climate Change Unit of JRC's Institute for Environment and Sustainability (IES), and called 'Global crop and site specific Nitrous Oxide emission Calculator (GNOC)'. This new approach is based on a statistical analysis of the same dataset of measured N₂O data used in IPCC tier1, and for that reason, when averaged over a large area, our results approach those of IPCC tier1. By contrast the previous soil chemistry model approach, although more sensitive to local conditions, can give systematic biases in the average compared to measured data.

Note that with the new GNOC modelling tool a reference case is not needed, since the emissions from an unfertilised control plot are subtracted internally in the model.

In spite of the thoroughness of these calculations, significant uncertainty remains, and some recent studies have suggested that field N₂O emissions may be significantly underestimated in such 'bottom-up' calculations.

For more details see *WTT report*, section 3.4.2.

3.4.1.5 Energy and GHG balance

The figures in this section pertain to the neat fuels (ethanol and bio-diesel respectively). In practise they are most likely to be used in blends and the effects will be spread over a large number of vehicles. For biofuels the emphasis is on avoiding GHG emissions but also reducing dependence on fossil energy. The main plots therefore show fossil energy only. In the case of biofuels, both TTW fossil energy and CO₂ emissions are by

convention zero so the graphs show a single WTW bar. We discuss the relationship between fossil and total energy separately.

Ethanol

Figure 3.4.1.5-1 shows the WTW fossil energy requirement and GHG emissions for a number of ethanol pathways assuming a common 2020 model year DISI vehicle. Figure 3.4.1.5-2 shows the same information expressed as % savings compared to conventional gasoline. The same graphs based on a different vehicle (PISI and/or 2010 rather than 2020) would show higher figures but the same relative position for different WTT pathways.

Figure 3.4.1.5-1a/b WTW fossil energy expended and GHG emissions for ethanol pathways (2020+ DISI vehicle)

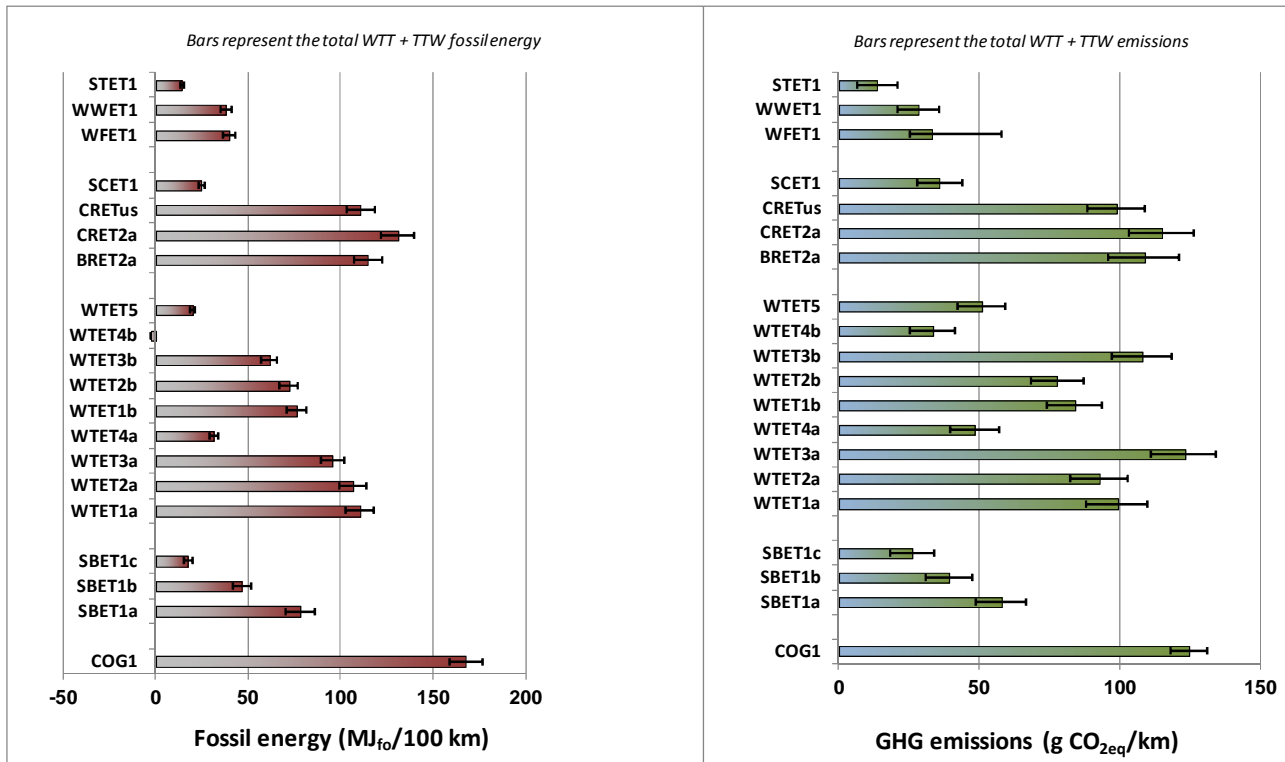

Key to pathway codes

COG1	Conventional gasoline
SBET1a	Sugar beet, pulp to animal feed, slops not used
SBET1b	Sugar beet, pulp to animal feed, slops to biogas
SBET1c	Sugar beet, pulp to fuel, slops to biogas
WTET1a	Wheat, conv boiler, DDGS to animal feed
WTET2a	Wheat, NG CHP, DDGS to animal feed
WTET3a	Wheat, lignite CHP, DDGS to animal feed
WTET4a	Wheat, straw CHP, DDGS to animal feed
WTET1b	Wheat, conv boiler, DDGS to electricity
WTET2b	Wheat, NG CHP, DDGS to electricity
WTET3b	Wheat, lignite CHP, DDGS to electricity
WTET4b	Wheat, straw CHP, DDGS to electricity
WTET5	Wheat, conv boiler, DDGS to electricity via biogas
BRET2a	Barley, /Rye, NG CHP, DDGS to animal feed
CRET2a	Maize (EU), NG CHP, DDGS to animal feed
CRETus	Corn (US)
SCET1	Sugar cane (Brazil), surplus bagasse to electricity
WFET1	Wood (farmed)
WWET1	Wood (waste)
STET1	Straw (wheat)

Figure 3.4.1.5-2 WTW expended fossil energy and GHG emissions savings for ethanol pathways compared to conventional gasoline (2020+ DISI vehicle)

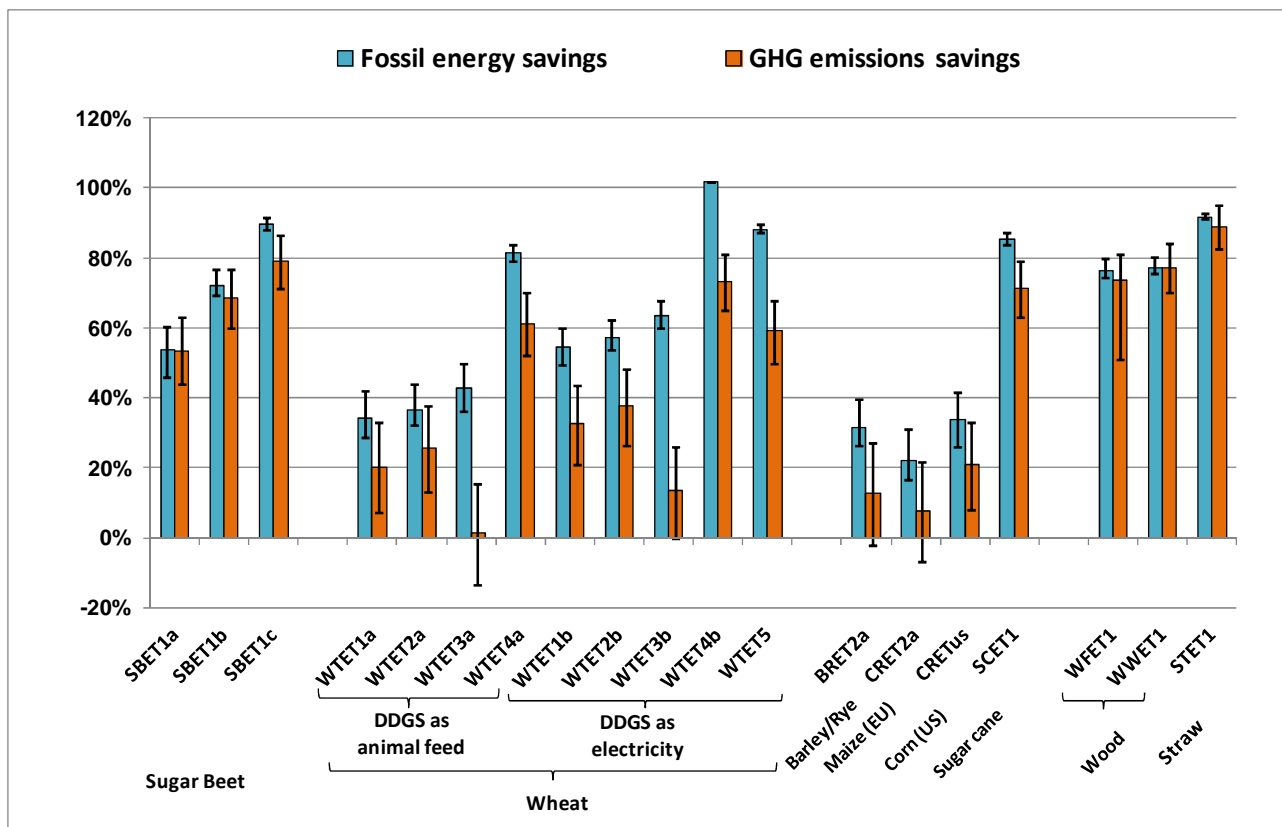

The different wheat pathways illustrate the large impact of both the energy source used for the process and the disposition of co-products. Not surprisingly the larger savings are obtained when co-products are used as energy source. This may, however, not always be the most economically attractive scheme. As long as the EU imports animal feed components such as soy meal, economics are, however, unlikely to favour use of co-products such as DDGS as fuels. WTET2a is probably most representative of standard practice (using a

natural gas fired co-generation plant and exporting DDGS as animal feed) and yields a modest 25% GHG saving compared to conventional gasoline. Other cereals yield even less. Even with the advantage of co-generation, using coal wipes out most of these gains for GHG emissions. Straw burning is of course very favourable from this point of view but has other limitations as discussed below.

Sugar beet yields over 50% GHG savings in all cases and significantly more when co-products are used as energy source when it is on a par with sugar cane and wood/straw pathways.

Sugar cane is a well-established route and gives attractive savings, mostly because the “bagasse” is used as fuel in the ethanol production process.

Advanced processes (from wood or straw) can also result in high savings, mostly because these processes use part of the biomass intake as fuel and therefore involve little fossil energy. The relatively large difference between the straw and wood case stem almost entirely from the process chemicals requirements indicated in the literature reference used. This is another indication that the actual processing scheme used is not indifferent to the final outcome in terms of energy and GHG.

Particularly for crops, fossil energy savings are larger than GHG emissions savings. This is due to the GHG contribution of field N₂O emissions which are also responsible for the relatively large GHG emissions uncertainty range.

- *The fossil energy and GHG emission savings from ethanol depend critically on the way it is produced. The lowest GHG emissions are obtained when co-products are used for energy production*

Ethanol in market blends E10 E20 and E85

Figure 3.4.1.5-3 shows the WTW fossil energy requirement and GHG emissions for E10, E20 and E85 using a number of ethanol pathways assuming a common 2020+ DISI vehicle. **Figure 3.4.1.5-4** shows the same information expressed as % savings compared to conventional gasoline.

The results shown reflect the blend to be used at maximum including a safety margin for fuel suppliers, i.e. E10/E20 are defined as 9.9/19.9%-vol. mix of ethanol into gasoline. For E85 we used 80% vol. in recognition of the fact that 85% cannot be reached all year round because of vapour pressure limitations. The ethanol mix is taken from [Hamelinck 2013] and shown in **Table 3.4.1.5-1**.

Table 3.4.1.5-1 EU Ethanol mix 2010 for market blends

Crop	representative pathway	share
Wheat	WTET1a	25%
Maize /Corn	CRET2a	20%
Sugar beet	SBET1a	30%
Sugar cane	SCET1a	14%
Others	BRET2a	12%

Figure 3.4.1.5-3 WTW fossil energy expended and GHG emissions for ethanol market blends (2020+ DISI vehicles)

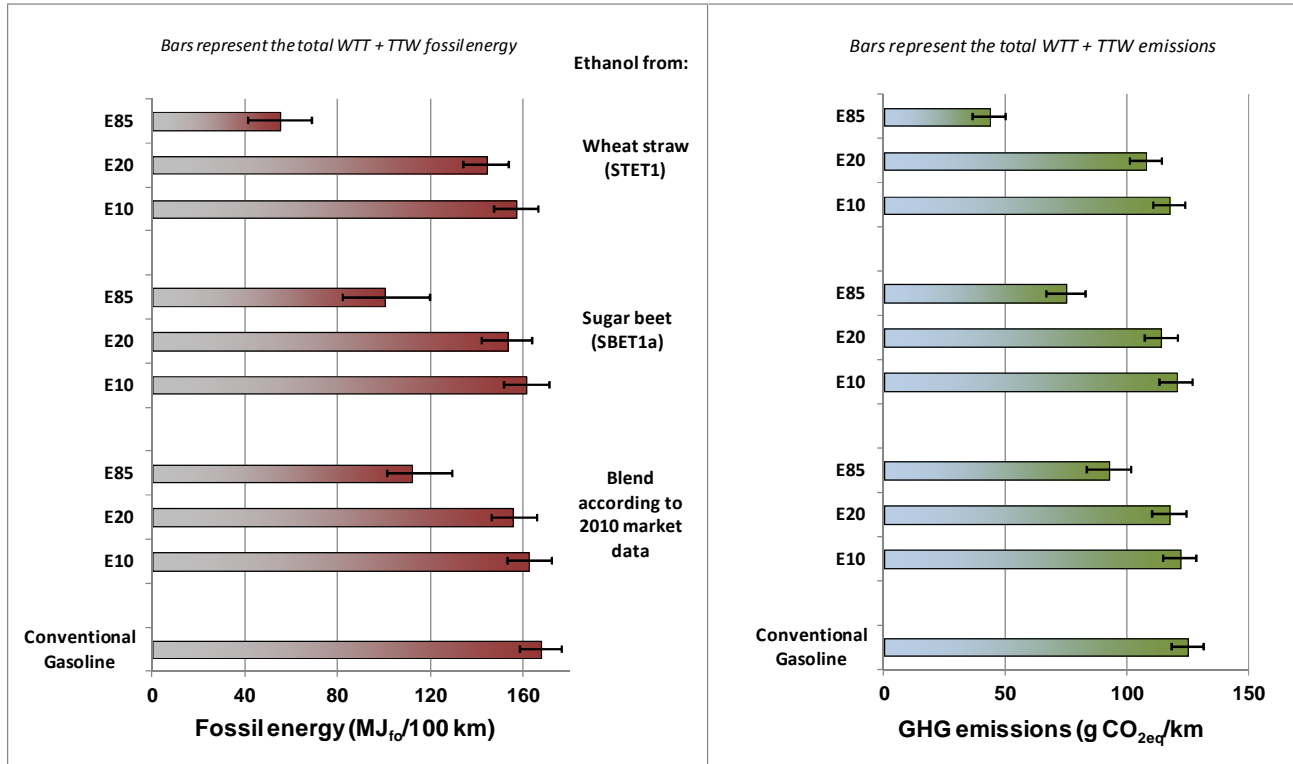
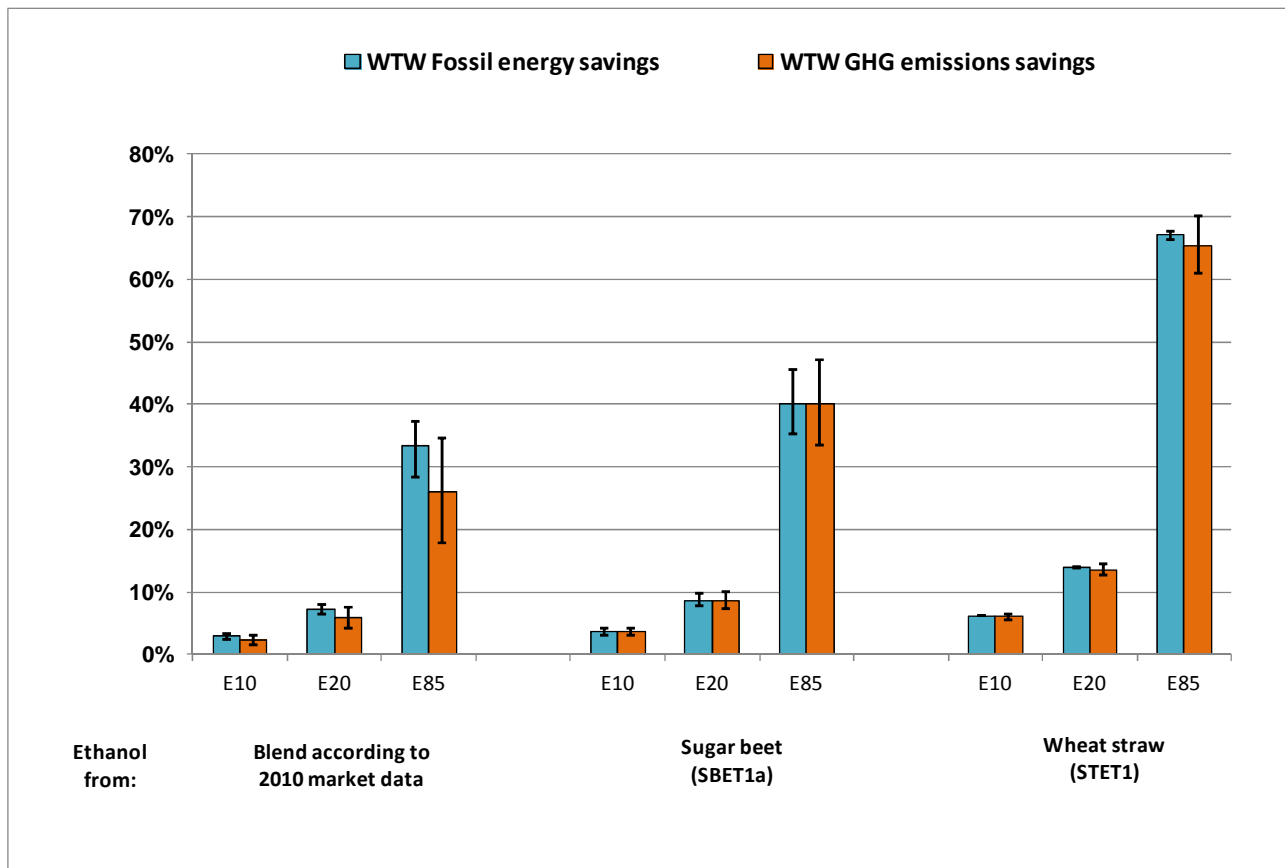

Figure 3.4.1.5-4 WTW expended fossil energy and GHG emissions savings for ethanol market blends compared to conventional gasoline (2020+ DISI vehicle)



For E20, it has been assumed that the engine can take advantage of the higher octane to increase efficiency (see section 3.4). Hence, WTW fossil energy and GHG saving are not only a function of Ethanol content. Furthermore, identical fossil gasoline quality and properties have been taken into consideration for the three market blends, but this might vary for E5, E10 and E20 market blends resulting in different WTW fossil energy and GHG savings.

Bio-diesel

Figure 3.4.1.5-5 shows the WTW fossil energy requirement and GHG emissions for a number of bio-diesel pathways. Figure 3.4.1.5-6 shows the same information expressed as % savings compared to conventional diesel fuel.

Figure 3.4.1.5-5a/b WTW fossil energy expended and GHG emissions for bio-diesel pathways (2020+ DICI vehicle)

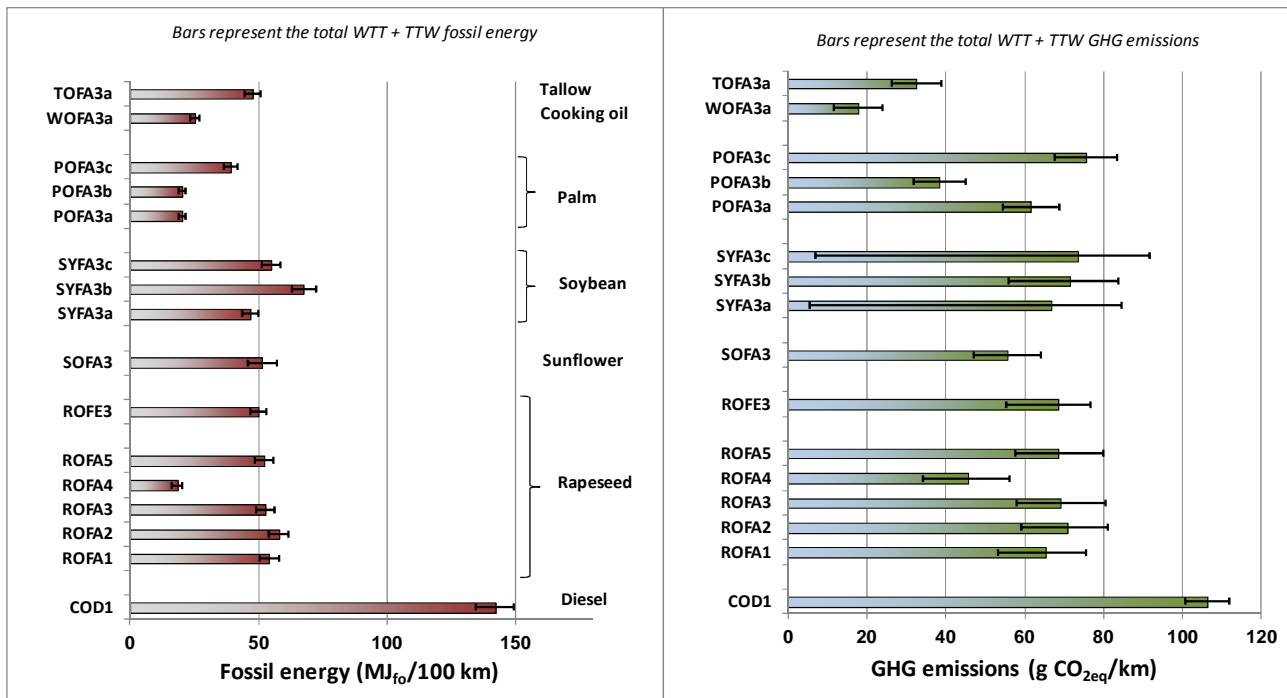

Key to pathway codes

COD1	Conventional diesel
ROFA1	Rape (RME), meal to animal feed, glycerine as chemical
ROFA2	Rape (RME), meal to animal feed, glycerine to animal feed
ROFA3	Rape (RME), meal to animal feed, glycerine to fuel
ROFA4	Rape (RME), meal to biogas, glycerine to fuel
ROFA5	Rape (RME), meal to animal feed, glycerine to hydrogen
ROFE3	Rape (REE), meal to animal feed, glycerine to fuel
SOFA3	Sunflower (SME), meal to animal feed, glycerine to fuel
SYFA3a	Soy (SYME), no till, oil to EU, meal to animal feed, glycerine to biogas
SYFA3b	Soy (SYME), no till, beans to EU, meal to animal feed, glycerine to biogas
SYFA3c	Soy (SYME), conv. agriculture, oil to EU, meal to animal feed, glycerine to biogas
POFA3a	Palm (POME), meal to animal feed, no CH4 recovery, heat credit, glycerine to biogas
POFA3b	Palm (POME), meal to animal feed, CH4 recovery, heat credit, glycerine to biogas
POFA3c	Palm (POME), meal to animal feed, no CH4 recovery, no heat credit, glycerine to biogas
WOFA3a	FAME from waste cooking oil
TOFA3a	FAME from tallow

Figure 3.4.1.5-6 WTW expended fossil energy and GHG emissions savings for bio-diesel pathways compared to conventional diesel (2020+ DICI vehicle)

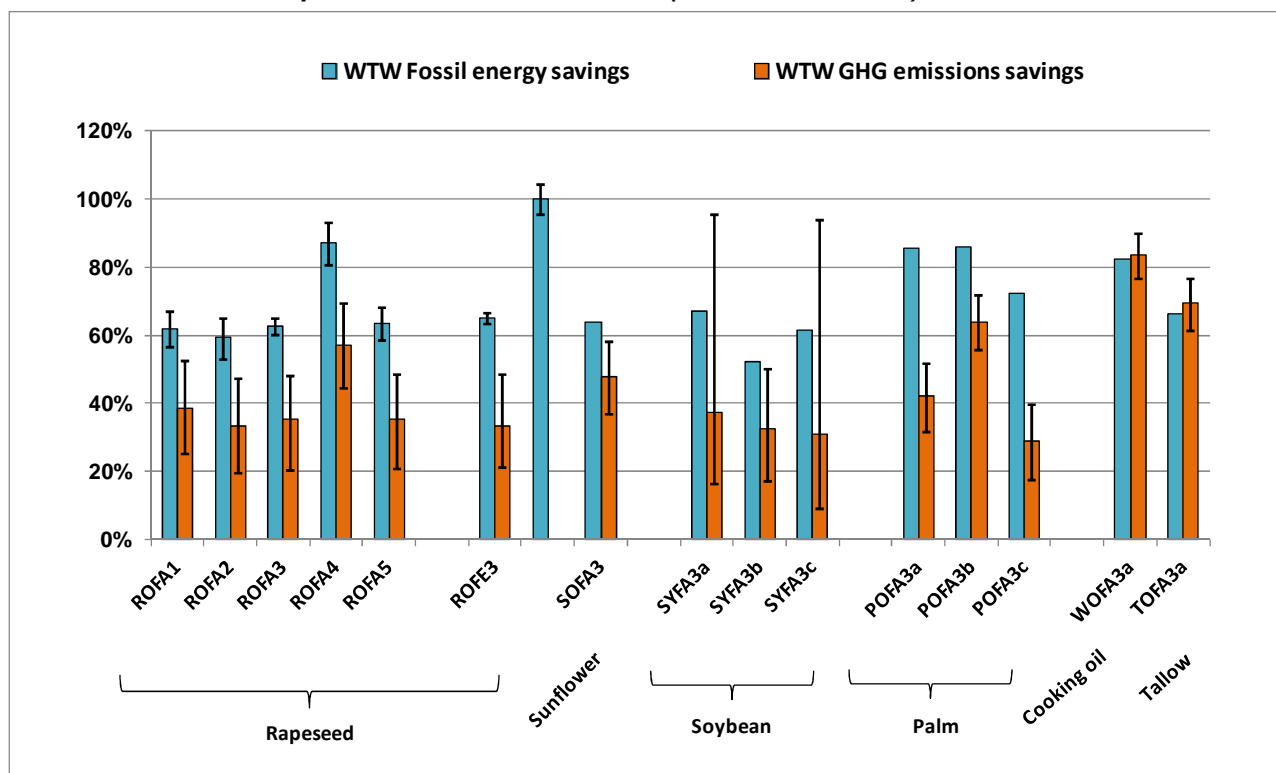

Bio-diesel is generally less energy-intensive than ethanol as the manufacturing process involves only relatively simple, low-temperature / low pressure steps. In GHG terms the picture is different because of the nitrous oxide emissions which account for an important fraction of the total and for most of the large variability ranges.

With meal used as animal fodder, RME (Rapeseed Methyl Ester) can save over 60% of the fossil energy and around 35% of the GHG emissions required for conventional diesel fuel. This could increase to nearly 90% and 60% if meal was used for biogas production. As would have been expected the balance of REE (Rapeseed Ethyl Ester) is somewhat more favourable than that of RME because of the use of partly renewable ethanol. SME (Sunflower seed Methyl Ester) gives even more favourable results for a variety of reasons including a smaller requirement for fertilisers. Most of the intensive farming areas of Europe are, however, more favourable to rape and this crop provides virtually all the European bio-diesel production today.

The impact of the disposition of the glycerine co-product is discernible but not major.

Similar savings can be achieved with SYME (soy beans) although the uncertainty range is very large in this case. This relates back to the large uncertainty on N₂O emissions from crops that soy meal is deemed to substitute. Transporting oil rather than beans is marginally more advantageous while "no-till" agriculture also brings a small improvement.

Palm oil methyl ester (POME) is less energy intensive than RME. The associated GHG emissions are much impacted by management of the plant effluent which is traditionally sent to an open pond where methane is released during the treatment process. Capturing this methane can tremendously reduce the overall footprint but this is not yet general practice.

It has also to be noted that there is much debate regarding the impact of increased Soy and Palm oil production on deforestation and, in the latter case, peatland drainage potentially leading to very large indirect GHG emissions. These effects are not included in the above figures.

FAME in market blend B7

Figure 3.4.1.5-7 shows the WTW fossil energy requirement and GHG emissions for B7 using a number of FAME pathways assuming a common 2020 DICI vehicle. Figure 3.4.1.5-8 shows the same information expressed as % savings compared to conventional diesel fuel.

The results shown reflect the blend to be used at the maximum concentration including a safety margin for fuel suppliers, i.e. B7 is defined as 6.9%-vol. mix of FAME into diesel. The FAME mix is taken also from [Hamelinck 2013] and shown in Table 3.4.1.5-2.

Table 3.4.1.5-2 EU FAME mix 2010 for B7 market blend

Crop	representative pathway	share
Rapeseed	ROFA3	48%
Soybean	SYFA3b	22%
Oil palm fruit	POFA3b	11%
Sunflower seed	SOFA3	4%
Others (wastes and residues)	WOFA3a	15%

Figure 3.4.1.5-7 WTW fossil energy expended and GHG emissions for B7 (2020+ DICI vehicle)

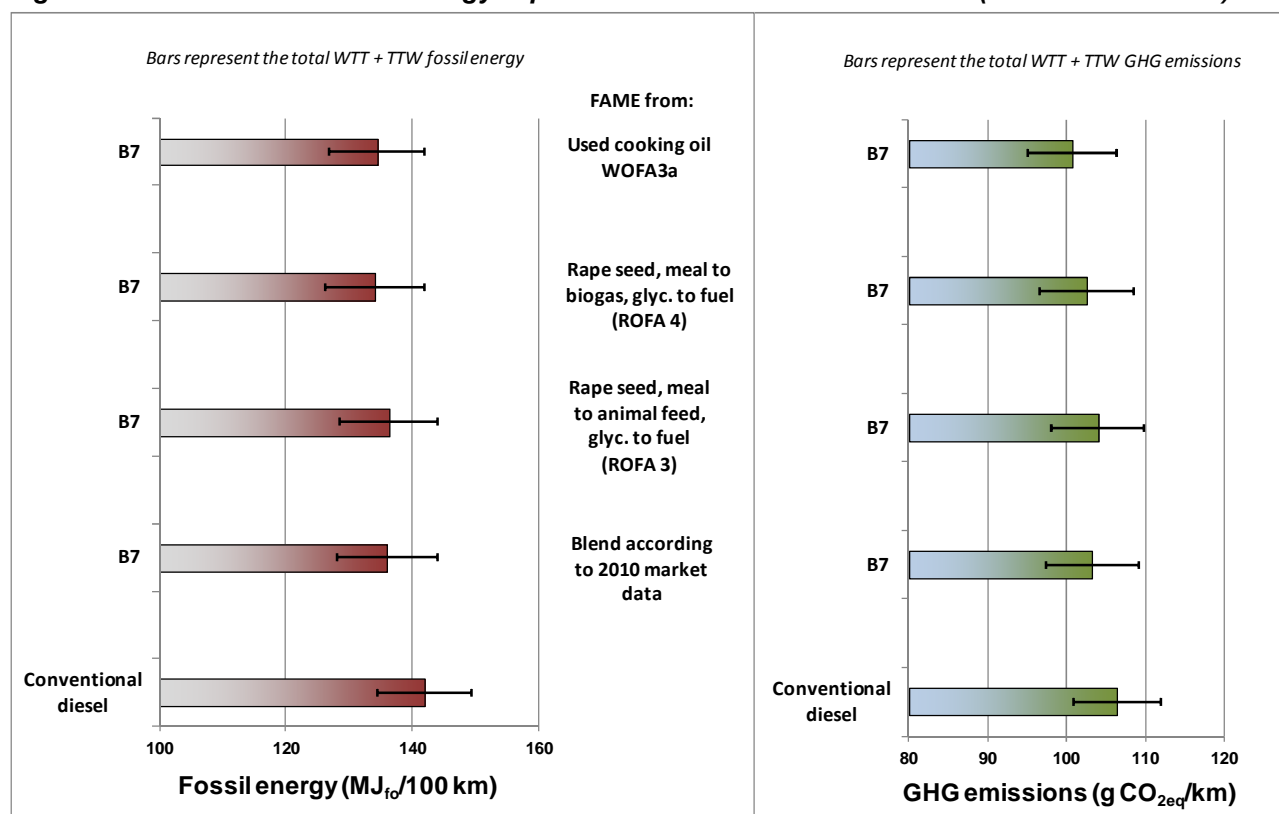
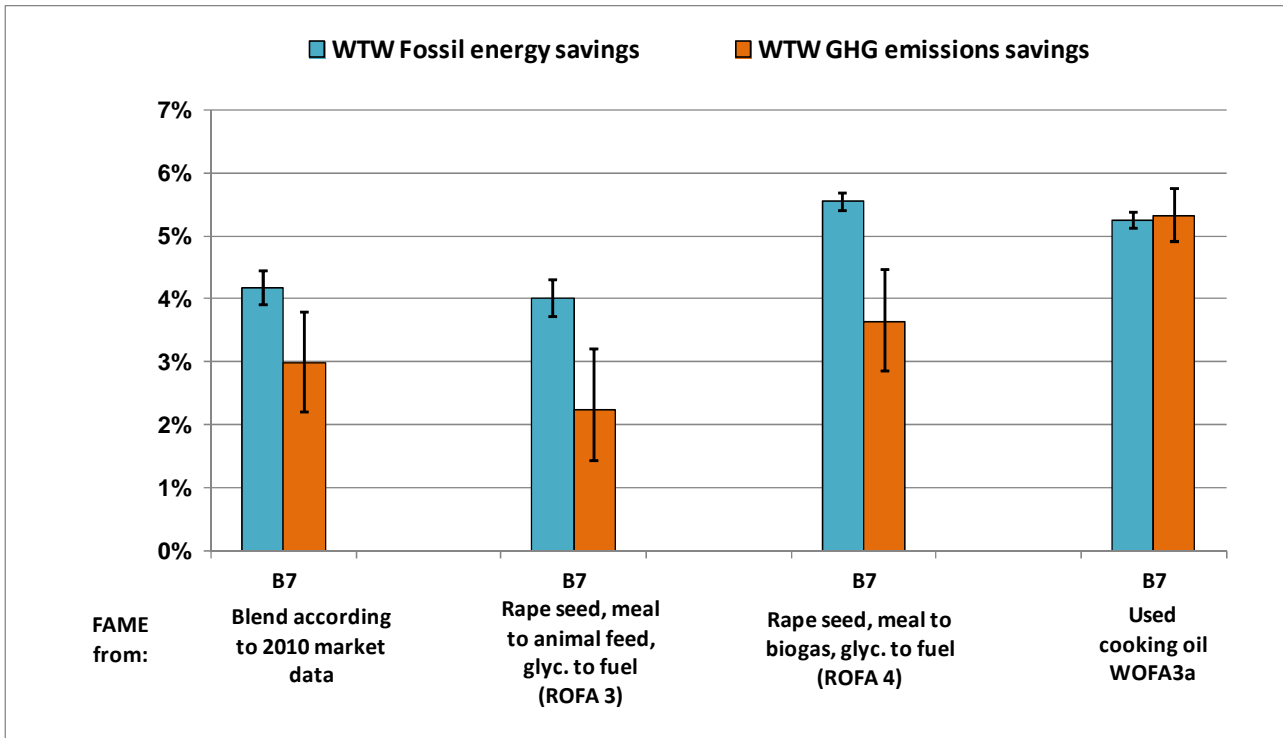

Figure 3.4.1.5-8 WTW expended fossil energy and GHG emissions savings for B7 compared to conventional diesel (2020+ DICI vehicle)



Hydrotreated vegetable oil

Figure 3.4.1.5-9 shows a selection of HVO pathways compared to the corresponding bio-diesel from the same oil. Figure 3.4.1.5-10 shows the same information expressed as % savings compared to conventional diesel fuel.

Although hydrogen manufacture is energy and GHG intensive (we have assumed it is made by steam reforming of natural gas), this is compensated for by the higher energy content of the final product as compared to conventional bio-diesel. Overall HVO is slightly more energy-intensive than a bio-diesel from the same oil and very slightly more GHG-intensive, although the uncertainty ranges are overlapping. There is a small difference between the two technologies considered, although not significant for GHG emissions.

Figure 3.4.1.5-9a/b WTW fossil energy expended and GHG emissions for selected HVO pathways (2020+ DICI vehicle)

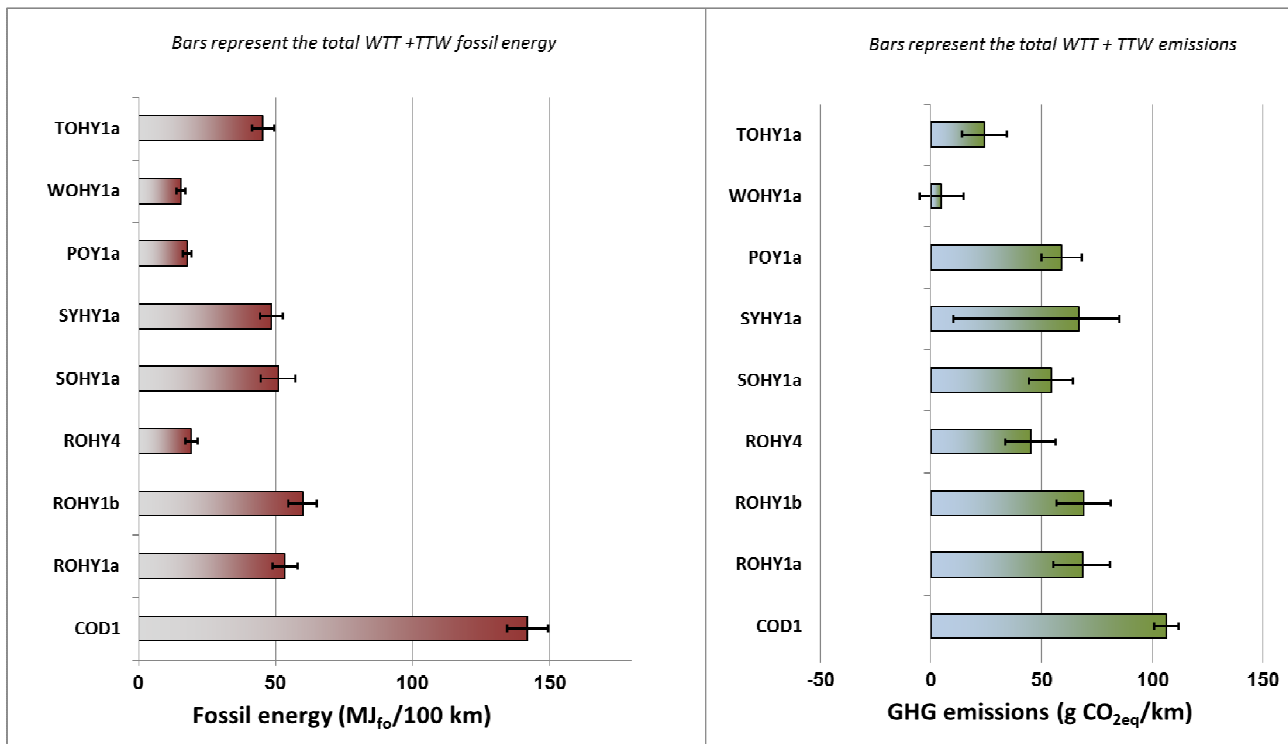

Key to pathway codes

COD1	Conventional diesel
ROHY1a	Rape seed, meal to animal feed, NexBTL
ROHY1b	Rape seed, meal to animal feed, UOP
ROHY4	Rape seed, meal to biogas, NexBTL
SOHY1a	Sunflower, meal to animal feed, NexBTL
SYHY1a	Soy beans, no till, oil imported into EU, NexBTL
POY1a	Palm, no CH4 rec., heat credit, NexBTL
WOHY1a	Waste cooking oil
TOHY1a	Tallow oil

Figure 3.4.1.5-10 WTW expended fossil energy and GHG emissions savings for selected HVO pathways compared to conventional diesel (2020+ DICI vehicle)

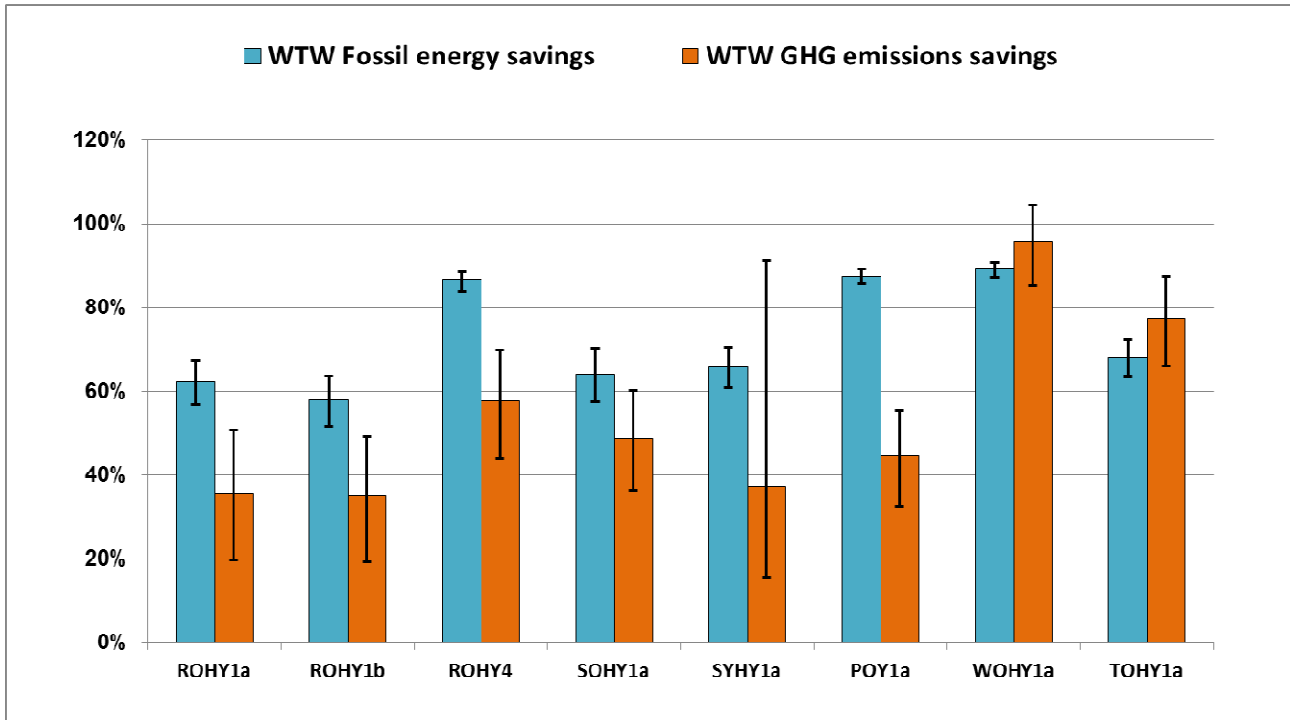

- The fossil energy and GHG savings of conventionally produced biofuels such as ethanol and biodiesel are critically dependent on manufacturing processes and the disposition of co-products.
- The GHG balance is particularly uncertain because of nitrous oxide emissions from agriculture.
- When upgrading a vegetable oil to a road fuel, the trans-esterification and hydrotreating routes are broadly equivalent in terms of GHG emissions.
- Current E10 and B7 market fuels deliver a fossil energy savings of 3-4% and GHG savings of 2-3%, respectively.

Fossil energy versus total energy

The fossil energy savings discussed above should not lead to the conclusion that these pathways are energy-efficient. Taking into account the energy contained in the biomass resource one can calculate the total energy involved. **Figure 3.4.1.5-11** shows that this is several times higher than the fossil energy involved in the pathway itself and two to three times higher than the energy involved in making conventional fuels. These pathways are therefore fundamentally inefficient in the way they use biomass, a limited resource.

Figure 3.4.1.5-11a/b WTW total versus fossil expended energy (2020+ DISI vehicle)

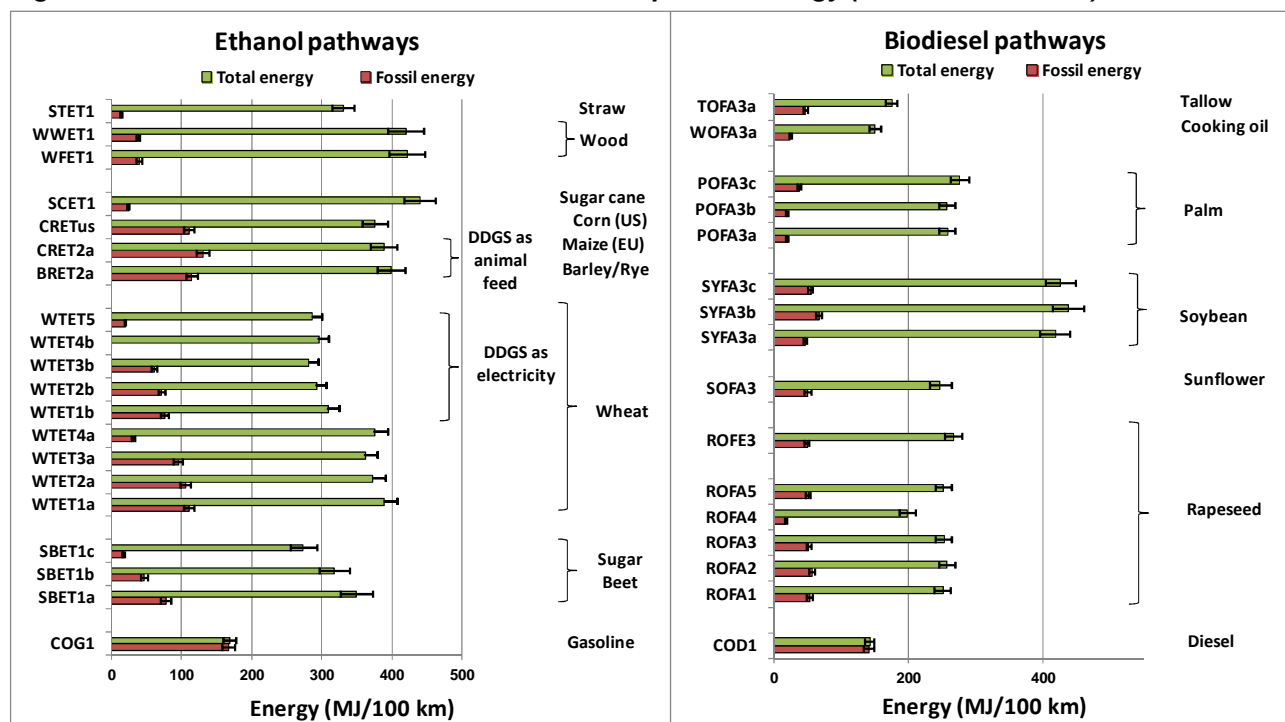

3.4.1.6 Impact of land use changes on GHG balances

The largest potential for expanding EU agricultural production for biofuels would be to increase the arable area at the expense of grazing land. However, there are very serious greenhouse-gas consequences to ploughing up grassland. The change in land-use results in a reduction in the organic carbon stored in the soil. Although this only happens once, the effect is large and the carbon released would negate the GHG savings of biofuels for many decades. Similar considerations apply to use of forest land for short rotation forestry.

We conclude that planting anything on grazing or forest land would be, in the short and medium term, counter-productive with regards to GHG reductions.

Currently, government aspirations for biofuel production go beyond the levels that can be produced on existing arable land: the Renewable Energy Directive mandates 10% renewable energy in transport energy by 2020, and the US Renewable Fuel Standard calls for 36 billion US gallons of renewable fuel by 2022, enough to replace about a quarter of US gasoline consumption. There is an on-going debate regarding the indirect impact of such policies on land utilisation in Europe, the USA and the rest of the world. This is a complex issue involving many parameters and variables and the outcome is highly uncertain. In this study we have purposely not taken into account such impacts which should therefore be added whenever a consensus is formed with regards to methodology and magnitude.

Land use changes are discussed in more depth in *WTT report*, Section 3.4.1.

3.4.1.7 Other environmental impacts of biofuels production

Soil quality/erosion

Sugar beet can cause soil erosion, especially if grown on the light soils typical of southern Europe. New techniques of inter-sowing between cover crops can help. However, we do not expect that sugar beet

production would spread beyond areas of northern Europe with heavy soils. In wet areas, the heavy machinery used for harvesting sugar beet can cause soil compaction.

We already warned that increase of arable area would cause loss of soil organic carbon from grassland or forest: we assume it will not be allowed.

Continually removing straw instead of incorporating it in the soil will decrease the soil organic content, leading to poorer moisture retention. This should be a larger problem in light southern soils, but ironically this is where straw is most often removed, because its decomposition consumes nitrogen which has to be replaced. It is probably not a significant problem in the prime cereals-growing areas of Northern Europe where a high density of straw availability makes it most economical to site straw-to-biofuel conversion plants.

Eutrophication and acidification

Because intensive agriculture using fertilizers tends to cause eutrophication and acidification, increased crop production for biofuels would tend to exacerbate the problem. The driving force for intensification is crop price: hence meeting biofuels targets will probably cause more intensification of oilseed production than of cereals production. Sunflower, short rotation forest and other "advanced biofuels" crops generally use less fertilizer than the other crops, so have less impact.

Biodiversity

Growing energy crops instead of permanent crops and/or on land set aside for the preservation of natural habitats, would decrease biodiversity. A 2004 study by the European Environmental Agency [EEA 2004] concluded that the negative biodiversity impacts are high for rape, medium for sugar beet and low to medium for short rotation forestry. The use of wood residues was considered to have no impact.

Pesticide use affects biodiversity. Break-years encouraged by compulsory set-aside rules tend to reduce pests and diseases, so doing away with it would tend to increase pesticide use. Large increases of pesticide applications are needed if the frequency of sugar beet (and to a much lesser extent oilseed rape) crops in a rotation is increased beyond about one year in four. Sugar beet generally requires much more pesticide than other crops. Farmers might escape controls on pesticide levels if the crops are not for food.

Impact on water table

The increased growth of crops requiring extensive irrigation in arid areas will put pressure on water resources. For example sugar beet cultivation in Spain and Greece has a very high percentage of irrigated area (76 and 99% respectively as reported in Eurostat). In Italy it is lower but still over a third of the area compared with 6% for Durum wheat and 7% for sunflower. Water use per tonne of dry matter is around 200 litres for sugar beet and 300 litres for wheat.

Increased cultivation of trees can also lead to a lowering of the water table. Lowering of the water table can have significant impact on the natural environment in the area concerned.

Introduction of non-native species and GMOs

There is some risk that non-native energy crops could spread in the wild, because they lack natural predators. Using sterile varieties (including Genetically Modified Organisms (GMOs)) greatly reduce this risk. Some are concerned about GMOs in general, though.

3.4.2 MTBE and ETBE

Methyl-Tertiary-Butyl Ether or MTBE is a high octane blending component for gasoline. MTBE was widely used in US gasoline until water contamination issues led to it being withdrawn in some areas. In Europe MTBE was introduced as one of the measures to recover octane after phasing out of lead in gasoline

Figure 3.4.2a/b WTW energy expended and GHG emissions for MTBE and ETBE pathways (2020+ DISI vehicle)

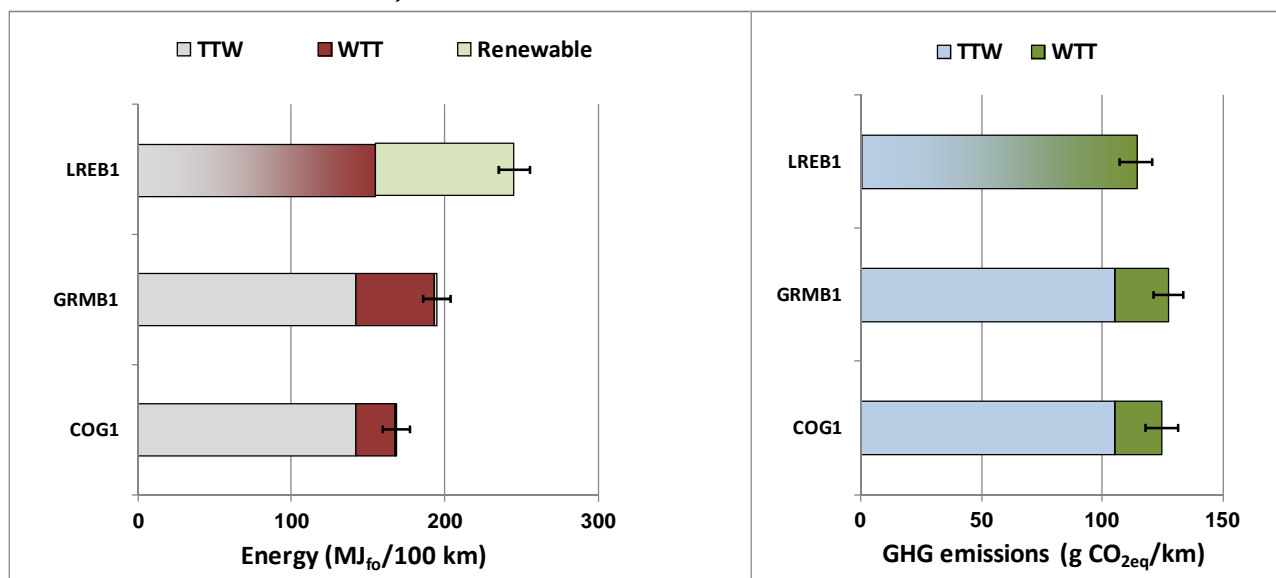

Key to pathway codes

COG1	Conventional gasoline
GRMB1	MTBE from remote natural gas
LREB1	ETBE from imported isobutene from gas field and bio-ethanol (WTET2a*)

* Wheat, NG gas turbine CHP, DDGS to animal feed, see Section 3.4.1.

MTBE is synthesised by reacting isobutene with methanol. Some isobutene is produced by refineries and petrochemical plants as co-product of cracking processes. Large MTBE plants include, however, isobutene manufacture via isomerisation and dehydrogenation of normal butane often from gas fields, near which the plants are often located. The entire process is fairly energy-intensive. In that sense MTBE is a fuel derived from natural gas. Marginal MTBE available to Europe is from that source and this is the pathway that we have investigated.

Ethanol can be used as a substitute to methanol to produce ETBE (Ethyl-Tertiary-Butyl Ether) which has very similar properties to MTBE. The main advantage of ETBE over ethanol as a gasoline component is its low vapour pressure. MTBE plants only require minor changes to be able to produce ETBE.

We have represented a pathway where isobutene is produced by isomerisation and dehydrogenation of normal butane imported from gas fields.

A significant proportion of ETBE used in the EU is manufactured in European oil refineries where isobutene is available in limited quantities as a co-product of the catalytic cracking process. Whereas the energy required by the ETBE plant itself is known, the energy associated with the production of isobutene cannot be estimated in a rational way. As a result this cannot be calculated as a discrete pathway. The approach we have taken to assess the net impact of this route is to compare a base case where ethanol is used as such and MTBE is produced in refineries, to the alternative where ethanol is turned into ETBE in replacement of MTBE. Results are shown in **Table 3.4.2** (see also **WTT report**, section 4.7).

MTBE requires more energy than gasoline although the GHG balances are more or less the same because MTBE manufacture uses essentially natural gas as energy source. ETBE has a lower fossil energy and GHG footprint as a result of the partial "renewability" of ethanol.

Table 3.4.2 WTW fossil energy and GHG emissions balances for "refinery" ETBE

Use of ethanol	Fossil energy MJ/MJ _{EtOH}	GHG g CO _{2eq} / MJ _{EtOH}
As ethanol	0.75	64.8
As ETBE	0.52	60.4
<i>Gasoline (for ref.)</i>	1.20	88.6

Overall, using ethanol as ETBE, through replacing methanol in a refinery, results in lower fossil energy and consumption and marginally lower GHG emissions than would be the case when using ethanol as such. The reason is that it is equivalent to eliminating fossil methanol and replacing it by extra gasoline which has a significantly lower energy footprint and marginally lower GHG emissions.

Although bio-methanol could in principle replace ethanol to produce bio-MTBE, this pathway has not been modelled.

- *With more favourable blending properties than ethanol, ETBE can provide an alternative to direct ethanol blending into gasoline. Fossil energy and GHG gains are commensurate with the amount of ethanol used.*

3.4.3 Synthetic Diesel fuels and DME

3.4.3.1 Sources and manufacturing processes

Synthetic diesel fuel

By synthetic diesel fuel we mean the product made by Fischer-Tropsch (FT) synthesis from "syngas" the mixture of carbon monoxide and hydrogen obtained by partial oxidation of hydrocarbons (e.g. coal or natural gas) or wood or by steam reforming of natural gas. The products of this process scheme are long-chain paraffins essentially free of sulphur and other impurities.

A hydrocracking unit is usually included in the FT process scheme to control the type of product being produced by splitting the chains appropriately. The main commercial products envisaged are diesel fuel (with or without the kerosene fraction), naphtha and some LPG. Most early plants also produce high value lubricant base oils and specialty products such as waxes but it is anticipated that these markets will soon be saturated and future plants will concentrate on producing large volume products.

We have considered three routes i.e.

- From natural gas (known as Gas-to-Liquids or GTL),
- From coal (known as Coal-to-Liquids or CTL),
- From woody biomass (known as Biomass-to-Liquids or BTL).

The syngas production process generates CO₂ that could be captured.

GTL

The GTL process is technically well-established although the economics have, in the past, not been sufficiently favourable for large scale development to occur. This has been changing in recent years with a combination of technological advances and more favourable economics and a number of large scale plants have been built. All such plants are located near a major gas field usually where the only alternative for bringing gas to market would be LNG. In this situation any captured CO₂ could be conveniently reinjected into the gas field. We have included a pathway with the corresponding CCS option.

This study starts from the present situation with European oil refineries supplying the virtual entirety of the road fuels market. Within the timeframe considered all identified alternatives to refinery production (e.g. the availability of GTL diesel) could only replace a limited amount of either gasoline or diesel fuel. The impact on the refineries is therefore considered in this context and this forms the basis of the marginal analysis through which the energy and CO₂ emissions associated with a marginal change in either gasoline or diesel fuel production are estimated.

For a further discussion of the credits that should be applied to GTL diesel reference is made to the **WTT report**, section 3.2.6.3.

CTL

Coal gasification is a well understood process that can be coupled to FT synthesis to deliver products very similar to GTL. There are very few plants in operation today but these schemes are attracting a lot of interest especially in combination with CO₂ capture and storage. We have included a pathway that shows this option.

BTL

The wood gasification process is similar to that of coal gasification although using biomass creates specific issues related to, amongst others, the mineral content of certain biomass feedstocks, problems of slagging etc each biomass feed creating different problems. Adaptation of the FT synthesis to syngas of different origins revolves around purity, cleanliness and CO/H₂ ratio of the gas.

Another challenge is the scale at which such processes could be practically used. Integrated gasification and FT plants are complex and expensive with any feedstock and benefit greatly from economies of scale. Biomass, as a low energy density and relatively dispersed feedstock, does not fit well within the traditional industrial model and novel ways have to be developed to find acceptable compromises.

The current search for alternative transport fuels has increased the level of interest for the BTL route and a number of pilot and demonstration projects have been pursued although no concrete route to a commercial scale project has been pioneered so far. These will always be complex engineering projects and will require many practical problems to be resolved before they become reliable and commercially viable. The major challenges for achieving this should not be underestimated. The potential rewards from these processes in terms of feed flexibility, quality of the products and very low GHG emissions justify further research and development.

The pulp and paper industry may provide a promising route for making significant amounts of synthetic fuels from woody material. This is the so-called "black liquor" route. Black liquor is a co-product of paper pulping that contains the lignin part of the wood. It is commonly used as internal fuel to power paper mills. Through gasification rather than simple burning of the black liquor one can generate syngas and therefore synthetic fuels. The energy balance of the paper mill must then be re-established by burning additional waste or low value wood. The net result is production of synthetic fuels from wood at a very high combined efficiency.

Diesel synthesis from electricity via methanol

At least in theory there is a route from electricity (which would have to be renewable for any scheme to make sense) to a diesel-like hydrocarbon product via hydrogen (produced by electrolysis) combined with CO₂ (from e.g. the flue gases of a power station) to form methanol which can then be transformed into paraffinic hydrocarbon chains. These processes have been described but there is no practical realisation even at the pilot stage. Nevertheless we have included this as a preliminary pathway.

DME

DME is to diesel what LPG is to gasoline. It is gaseous at ambient conditions but can be liquefied at moderate pressure. As a fuel for compression ignition engines it has very attractive characteristics, burning very cleanly and producing virtually no particulates (a dedicated DME vehicle would probably not require a particulate filter but would need a purpose-designed fuel handling and injection system).

DME is synthesised from syngas and can therefore be produced from a range of feedstocks. The synthesis process is very similar to that of methanol and has a similar efficiency, somewhat higher than the efficiency of the synthetic hydrocarbon processes. The most likely feedstock in the short term is natural gas but coal or wood can also be envisaged. Should DME become a major fuel, future plants would be most likely to be similar to GTL plants i.e. large and located near a major gas field. CCS could be conveniently applied in this case, particularly because CO₂ has to be separated in the synthesis process and is, therefore, already "captured" anyway. However, because DME synthesis is simpler than FT, smaller plants located in Europe and fed with imported gas can also be envisaged.

The black liquor route mentioned above is eminently suitable for DME (or methanol) and is in fact more likely to be developed to produce these fuels rather than BTL, chiefly in Scandinavia.

A dedicated distribution network and dedicated vehicles would be required. The practical and commercial magnitude of the task of building such a network, building and marketing the vehicles as well as customer acceptance must not be underestimated. Use of this otherwise attractive fuel in fleets may be worth considering in certain cases, albeit with specially adapted vehicles.

3.4.3.2 Energy and GHG balances

The GTL, CTL and BTL processes can produce a variety of products. When focussing on the diesel fuel product from these processes, one is confronted with the issue of allocation of production energy. Although diesel fuel often is the main product in volume terms, its fraction in the total product will not, in practice, exceed 75% (higher yields may be achieved by recycling lighter products but at a considerable cost in energy). Naphtha takes the largest share of the balance and can hardly be considered as a co-product being of the same nature as diesel fuel and usable in applications where it also would displace petroleum products. There is no technical basis for arguing that more or less energy and emissions are associated to specific products so that, in this case, allocation on the basis of energy content is justified (i.e. that all products are produced with the same energy efficiency). We have taken this view which leads to consider that all products and their disposition are independent of each other (see also *WTT report, section 3.2.6*).

Figure 3.4.3.2-1a/b shows the energy and GHG balances for a selection of synthetic diesel and DME pathways. For comparison conventional diesel, CNG and LPG are also shown in the graphs as a reference. **3.4.3.2-2** shows the same information expressed as % CO₂ savings compared to conventional diesel fuel.

The combined process of primary energy conversion and FT synthesis is energy-intensive, more so for coal and wood than for natural gas. This is mainly because the overall process is more straightforward and more energy efficient with gas. Also future GTL and CTL plants are expected to be very large and highly heat integrated. This is likely to be less so in smaller wood conversion plants where the size may be dictated by the raw material availability/collection and such complexity may not be economically justified.

GTL is notably more energy-intensive than conventional diesel fuel. In GHG terms the difference is small because of the beneficial effect of using natural gas rather than crude oil as the primary energy source. CCS reduces CO₂ emissions, although not by a massive amount (the fuel itself is still based on fossil carbon), at a cost of additional energy.

Figure 3.4.3.2-1a/b WTW energy requirement and GHG emissions for synthetic diesel and DME pathways (2020+ DISI & DICI vehicles)

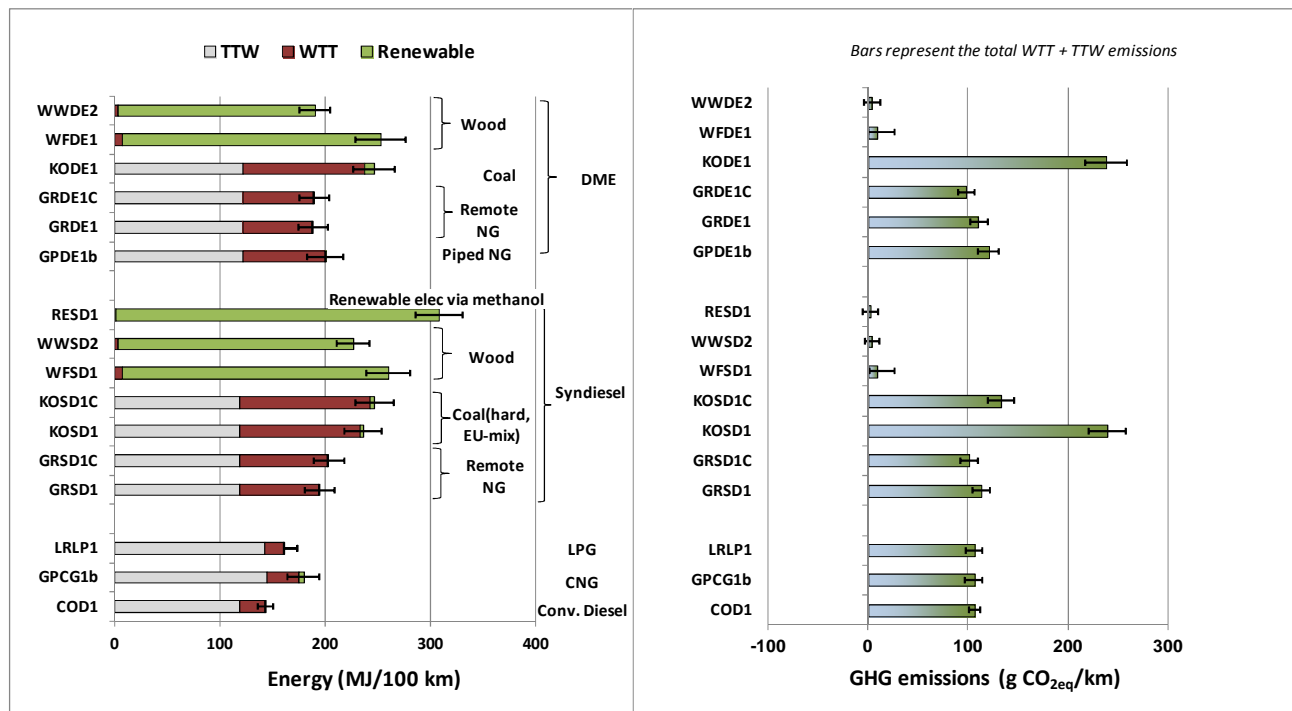

Key to pathway codes

COD1	Conventional diesel
GPCG1b	CNG from imported NG 4000 km (typically Middle East)
LRLP1	LPG imported from remote gas field

GRSD1	Remote NG to syndiesel, GTL plant near gas field
GRSD1C	Remote NG to syndiesel, GTL plant near gas field + CCS
KOSD1	Coal (hard, EU-mix) to syndiesel, CTL plant in EU
KOSD1C	Coal (hard, EU-mix) to syndiesel, CTL plant in EU + CCS
WFSD1	Wood (farmed) to syndiesel
WWSD2	Wood (waste) to syndiesel via black liquor
RES1	Renewable electricity to syndiesel via methanol

GPDE1b	Piped NG (4000 km) to DME, synthesis plant in EU
GRDE1	Remote NG to DME, synthesis plant near gas field
GRDE1C	Remote NG to DME, synthesis plant near gas field + CCS
KODE1	Coal (hard, EU-mix) to DME, synthesis plant in EU
WFDE1	Wood (farmed) to DME
WWDE2	Wood (waste) to DME via black liquor

Figure 3.4.3.2-2 WTW expended fossil energy and GHG emissions savings for pathways compared to conventional diesel (2020+ DICI vehicle)

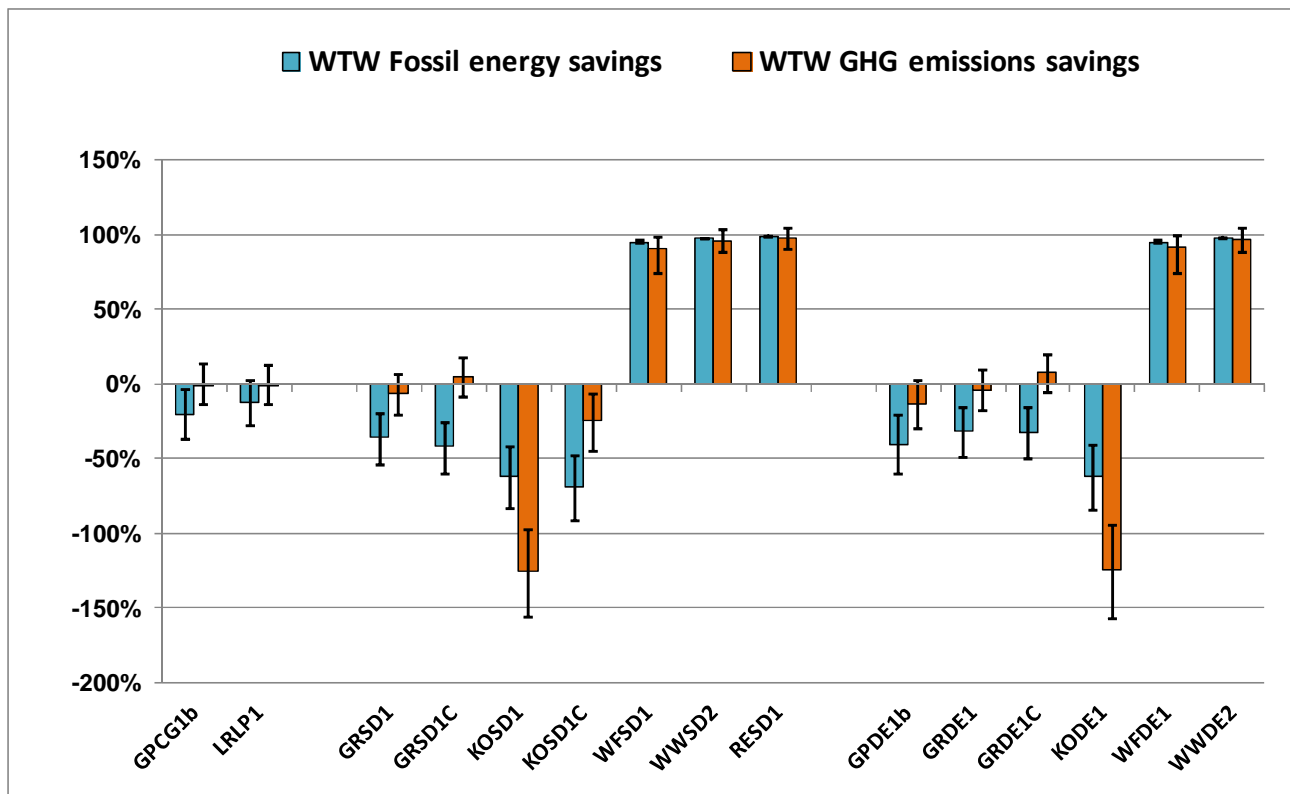

- High quality diesel fuel can be produced from natural gas (GTL) and coal (CTL). GHG emissions from GTL diesel are slightly higher than those of conventional diesel, CTL diesel produces considerably more GHG.

The higher efficiency of the synthesis process gives DME a slight advantage on the synthetic diesel fuel from the same source. In the DME process, the sole product is DME which translates into high yield of fuel for diesel engines compared to FT diesel in the case of which other products (mostly naphtha) are also produced.

- *DME can be produced from natural gas or biomass with better energy and GHG results than other GTL or BTL fuels. DME being the sole product, the yield of fuel for use for diesel engines is high. However, DME can only be used in dedicated vehicles*

CNG obtained with liquefied gas from the same remote location is still more advantageous than either GTL diesel or DME in WTW both energy and GHG terms.

Here again the wood pathways hardly produce any GHG because the main conversion process is fuelled by the wood itself although they are not particularly energy efficient. The black liquor route (BL) is even more favourable with lower energy consumption and very low GHG emissions.

- *New processes are being developed to produce synthetic diesel from biomass (BTL), offering lower overall GHG emissions, though still high energy use. Such advanced processes have the potential to save substantially more GHG emissions than current bio-fuel options.*
- *Synthetic diesel from electricity and CO2 capture needs still considerable research.*

4 Externally chargeable vehicles and fuels

4.1 Vehicles

Based on the accelerated technological development and affordability of electric energy storing devices (e.g. Li-Ion batteries), electrification concepts of the automobile are becoming increasingly important. This leads to a range of new electrified vehicle and powertrain concepts that will enter the market in the foreseeable future.

These vehicle concepts will use electricity either as the sole energy source or in addition to the on-board stored consumable (liquid or gaseous) fuel used in an Internal Combustion Engine (ICE). In order to compare the GHG balance of externally chargeable electric vehicles that can store a certain amount of externally generated energy on board for the use of mechanical propulsion, we need to take account of the GHG-emissions of the electrical energy used.

The energy mix using electricity from the vehicles battery or the stored liquid or gaseous fuel of PHEV and REEV may vary due to a range of parameters and customer choices such as different driving habits, road conditions and cabin comfort needs. To compare the energy demand and GHG balance of these externally chargeable electric vehicles with the other vehicle types in the WTW study, we applied the UN ECE R 101 protocol in addition to the NEDC. This is also in line with EU vehicle testing and registration.

The UN Vehicle Regulation UN ECE R 101, Revision 2 defines rules for evaluation of the (liquid or gaseous) fuel consumption or TTW CO₂ emissions of a PHEV or REEV with intermittent ICE operation, which is based on the consideration of Charge Depleting (CD) and Charge Sustaining (CS) operation modes together with the electric driving range of the vehicle. The corresponding result for electric energy consumption is also based on the same UN ECE regulation applying the same parameters, if the fuel consumption (in CD and CS mode) is substituted by the corresponding electric energy consumption values. The driving range in electric mode is considered in the same manner. For the detailed formulae, please see **TTW V4 report** section 4.2.

This chapter explores the following externally chargeable electric vehicle concepts with different levels of electricity utilisation (see also **TTW report** section 3.3 and 3.4):

- PHEV: an externally chargeable hybrid electric vehicle with limited electric performance and electric range ("urban capable" PHEV), although the possibility to drive in electric mode is expanded by the possibility to plug the battery to an electricity source.
- REEV: externally chargeable hybrid electric vehicle with full performance in electric mode and with an auxiliary ICE engine for extended range.
- BEV: a pure battery electric vehicle with an electric motor to propel the vehicle, with full performance in electric mode but still limited electric range.

Together, we call these electrified vehicle concepts xEVs. All xEV electric traction motors are based on Brushless Permanent Magnet Synchronous Motor technology. Electric traction -motor power densities range from 1200W/kg for BEV to 750W/kg for HEV in 2010 and gain about 10% increased power densities for the 2020+ configurations.

Some energy loss occurs during charging from mains electricity, through the battery and power electronics, for all externally chargeable configurations. We have included 20% charging losses for 2010 and a reduced 15% charging loss for 2020+ for all configurations.

Table 4.1-1 displays the fuel/powertrain options analysed in this report while **Table 4.1-2** details some technical data for these vehicles. Full details of the vehicle configurations are given in the **TTW report**.

Table 4.1-1 xEV fuel/powertrain configurations

Powertrain \ Fuel	PHEV20 DISI	REEV80 SI	PHEV20 DICI	REEV80 CI*	BEV
Gasoline	Blue	Blue			
Gasoline E10 (market blend)	Yellow	Yellow			
Gasoline: E20 (high RON)	Blue	Blue			
Diesel			Blue	Light Blue	
Diesel B7 (market blend)			Yellow	Light Blue	
E85	Blue	Blue			
FAME			Yellow	Yellow	
Syndiesel			Yellow	Yellow	
HVO			Yellow	Yellow	
Electricity	Blue	Blue	Blue	Light Blue	Blue

All configurations modelled for both 2010 and 2020+ (except when stated otherwise)

Colour coding

- Modelled in detail with the vehicle simulation tool
- Exceptions:
REEV80 FC** and REEV80 CI* only modelled for 2020
REEV80 CI* modelled for two different layouts
- Derived from simulations using the relevant fuel

Table 4.1-2 Data for the 2020+ xEVs configurations

xEVs Configurations 2020+	PHEV20 DISI	REEV80 SI	BEV	PHEV20 DICI	REEV80 CI (Variant 1)	REEV80 CI (Variant 2)	
	Gasoline ²	Gasoline ²	Electricity	Diesel ³	Diesel ³	Diesel ³	
Powertrain							
Displacement	L	1,0	1,2	-	1,6	1,2	0,9
No. of Cylinders	---	IL3	IL3	-	IL4	IL3	IL2
Power	kW	70	47	-	85	63	46
ICE mass	kg	135	130	-	165	145	115
Transmission mass	kg	80	10	10	80	10	10
Powertrain mass change ¹	kg	+30	-45	-175	+30	-60	-90
Storage System							
Fuel Tank Capacity	L	25	25	-	25	25	25
Tank System mass	kg	15	15	-	15	15	15
Fuel mass	kg	19	19	-	21	21	21
Storage System mass change ¹	kg	-7	-7	-41	-8	-8	-8
Electric Components							
e-Motor mass ⁴	kg	36	58	51	36	58	58
e-Motor power: peak/cont.	kW	38 / 19	75 / 38	70 / 37	38 / 19	75 / 38	75 / 38
Generator mass (2 nd e-motor)	kg	-	35	-	-	40	35
Battery mass ⁴	kg	59	95	175	59	95	95
Battery Maximum Power	kW	50	90	90	50	90	90
Battery Energy (Total / Available)	kWh	2,7 / 1,8	11,8 / 9,1	22,1 / 18,4	2,7 / 1,8	11,8 / 9,1	11,8 / 9,1
xEV wiring harness mass	kg	15	20	20	15	20	20
eComponents mass change ¹	kg	+110	+208	+246	+110	+213	+208
Vehicle							
Curb weight (incl. driver, 90% fuel)	kg	1333	1356	1230	1392	1405	1370
Performance mass: Curb + 125kg	kg	1458	1481	1355	1517	1530	1495
Gross vehicle mass: Curb + 550kg	kg	1883	1906	1780	1942	1955	1920
1) Reference is the 2020+ DISI vehicle for SI & BEV configurations and the 2020+ DICI for the CI configurations 2) Same vehicle is assumed for the different fuel variants Gasoline, Gasoline E10 market bl., Gasoline E20 High RON & E85. 3) Same vehicle is assumed for the different fuel variants Diesel, Diesel B7 market blend, FAME, FT-Diesel & HVO. 4) Masses for e-motor and battery include housing, power electronics and cooling system.							

4.1.1 Plug-in Hybrid Electric Vehicles (PHEV)

A parallel configuration including full hybridization (i.e. the vehicle can be driven from battery powered alone over a certain distance) is selected for PHEV, combining an ICE with an electric motor and a High Voltage Battery. For 2010 the parallel configuration includes a 6 speed automatic transmission with a torque converter as launch element whereas for 2020+ the transmission is changed to an 8-speed automatic transmission and the torque converter is replaced by a dry clutch. The battery powered driving range for the PHEV is 20km, whereas for the HEV it is restricted to a few km, basically allowing launching the vehicle in electric driving mode Figure 4.1-1 shows the high level layout of the powertrain.

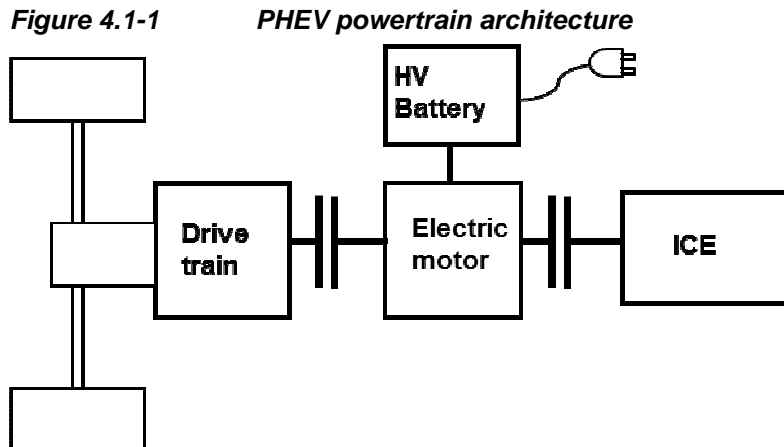

4.1.2 Range-Extended Electric Vehicles (REEV)

A series configuration is selected for the REEV with SI and CI ICEs (see **Figure 4.1-2**). The battery powered driving range for the REEV is 80km. Both spark and compression ignition engines have been modelled. The SI and CI REEV are equipped with a 35L standard size fuel tank for 2010, and a reduced 25L fuel tank for 2020+.

The series hybrid powertrain layout of the REEV results in a set up where the speed and load of the ICE are independent from the driving conditions. Therefore the Range Extender module (system of ICE and generator) is optimized to work along its optimal operating line (i.e. the line that combines the lowest fuel consumption per generated electric power for all possible operation points). The ICE Off Mode is applied, in case of available Battery energy, to avoid low efficiency operation of the ICE. In particular it is applied in case of low vehicle velocity if the required electric power is lower than a calibrated threshold.

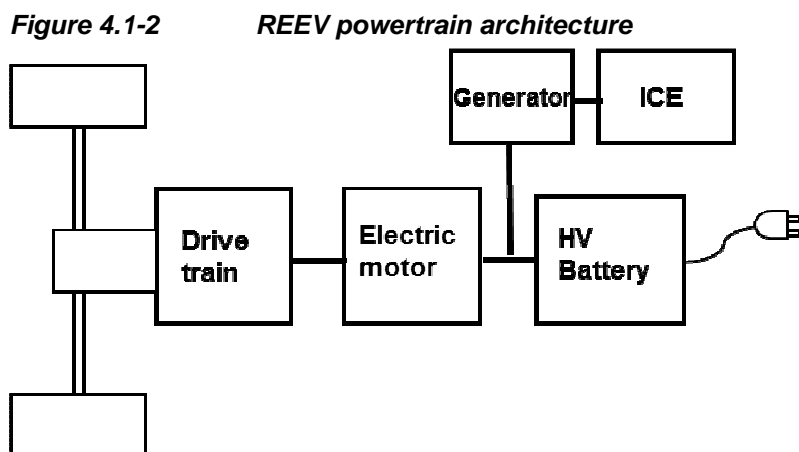

4.1.3 Battery Electric Vehicles (BEV)

The battery powered driving range for the BEV is given as 120km for 2010 and 200km for 2020+. A one-gear transmission is used. Battery system energy densities are 90Wh/kg in 2010 and 120Wh/kg for BEV in 2020+ configurations. The powertrain layout is shown in **Figure 4.1-3**.

Figure 4.1-3 BEV powertrain architecture

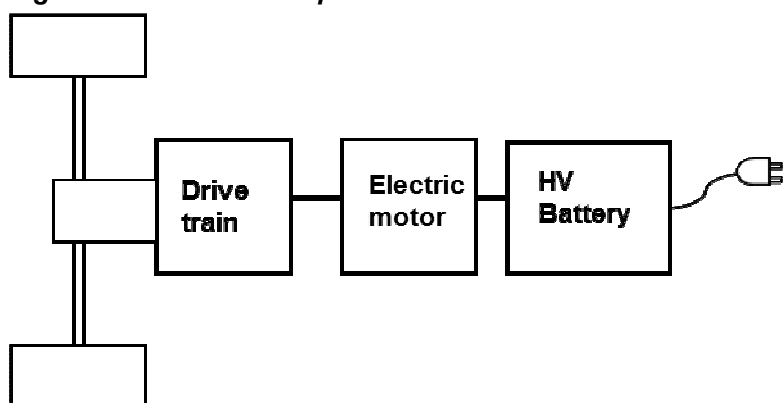

4.1.4 xEV operational strategies

The xEV configurations considered in this study feature the operational strategies defined in **Table 4.1.4**.

Concerning Start-Stop, Regenerative Braking and Battery Assistance, their activation is a straightforward consequence of the driver behaviour and the actual vehicle status. Stop-Start is activated if the vehicle is at standstill and if certain pre-defined vehicle parameters allow (e.g. ICE temperature is above a certain limit, battery State Of Charge (SOC)). Regenerative braking is activated in case of a negative torque (deceleration) request by the driver. Battery Assistance is activated in case of a full load request by the driver.

ICE Load Point Moving (LPM) is applied to shift the operation of the ICE towards better efficiency conditions, and to increase the reserve of energy in the Battery that is available to be exploited e.g. during ICE Off Mode. The ICE LPM is typically activated at intermediate driving power request, if the ICE Off Mode is disabled. Battery Assistance (also called e-Boost) is applied to support the full load driving performance of the vehicle, if enough Battery energy is available. **Table 4.1.4** gives an overview of the applied strategies in the xEVs configurations.

Table 4.1.4 xEV operational strategies

xEV operational strategies	PHEV	REEV	BEV
Start & Stop	✓		
Regenerative Braking	✓	✓	✓
ICE Off Mode	✓	✓	
ICE Load Point Moving	✓	✓	
ICE Alone Mode	✓	✓	
Battery Assistance	✓	✓	

4.2 Electricity production, transmission and distribution

Electricity is typically produced using: thermal energy from fossil fuels (coal, natural gas, oil products), thermal energy from nuclear fuel, and different energy forms from renewable sources such as biomass, wind, solar, hydropower, geothermal.

Due to differences in input energy sources and different technologies in power plants, both efficiency and GHG and pollutant emissions levels vary widely. The electric energy mix combining energy sources used to produce electricity in the EU27 affects several WTW energy pathways, with evident impacts on the overall efficiency of electric vehicles. Details on the EU27 electric energy mix, for year 2009, are provided in the **WTT Version 4a report** and relevant Appendices.

Consistently with the warning on uncertainty included in *section 2* of this report, the value of 540 g CO_{2eq}/kWh is unaltered for calculating WTW 2010 and 2020+ performance of electric vehicles.

Reasons supporting this decision are threefold and relate to: technology neutrality, data uncertainty/data consistency and the slow penetration rate of new technologies in the electric power generation system.

Technology Neutrality

The idea of forecasting 2020+ electric vehicle emissions by using specific 2020+ EU electric mix scenarios could be attractive but, in the scope of the WTW4 report, not appropriate: 2020+ technologies must be compared against values calculated or projected for the entire set of fuel/energy pathways. There is no specific reason to believe that the carbon content of electric energy will decrease more rapidly than the carbon content of other pathways

Data uncertainty / Data consistency

Drawing data from a variety of sources each characterised by specific assumptions is likely to increase the uncertainty and reduce the robustness of the WTW analyses. This is particularly true if data projections affect only one part of the energy system (e.g. the electric sector).

Slow renewal of power plants and unfavourable boundary conditions

Electric power plants are renewed quite slowly (the time of life of a power plant is in the order of 30-60 years), so the penetration rate of new technologies is relatively slow. A reasonable assumption for a 2010 to 2020 forecast is a slowing average growth rate of RES in Europe (with exceptions in some Member States), probably not exceeding the 3% necessary to reach the planned 20% share of RES for 2020. This is partly due to the relatively long life span of power plants as explained above, coupled with unfavourable boundary conditions.

On the technology side integration of RES in the traditional network is currently a partially solved problem. Smart grids are still at concept level so that the European Network is starting to be a bottleneck that hampers the dispatching to the users of all the renewable energy produced.

On the basis of the considerations above, we can expect that, for what concerns the EU electric mix, using 2010 WTT data for 2020+ WTW calculations may introduce an uncertainty off less than 3%, so negligible compared to the total WTW uncertainty.

4.3 2020+ Energy and GHG balances

The PHEV and REEV configurations in this study are capable of using both on-board stored liquid fuel for ICE-based propulsion or operating on electricity that has been externally charged into the HV battery for electric driving. As for HEV, these modes of operations in PHEV and REEV are blended depending on the control strategy. Also, when the vehicle decelerates, regenerative braking can store energy into the battery that originally stems from ICE-powered or electric driving. As illustrated in the figures below the energy mix of these vehicles may show very different WTW results due to the range of possible fuel/electricity combinations.

Battery electric vehicles (BEV) consume electricity only. The electricity generation used for charging of these vehicles thus plays a crucial role for the WTT GHG footprint of a BEV and hence for the WTW results.

For the following figures we have assumed charging at low voltage (LV). This low voltage slow charging of electric cars takes some time but on the other hand preserves the battery life and gives better charging efficiency. It can be concluded that slow charging at home (and mostly overnight) will be the dominant recharging approach for electric cars.

PHEVs

Figure 4.3-1 shows results for a spark ignited PHEV in 2020+ using a representative range of possible electricity pathways. Looking at the WTW energy use all options in the figure are similar besides those in which electricity is generated from manure or waste. The GHG figure shows that all are below 100g CO_{2eq}/km.

Figure 4.3-1a/b WTW total energy expended and GHG emissions for DISI-PHEV 2020+ configuration using conventional gasoline (ICE operation) and various electricity pathways

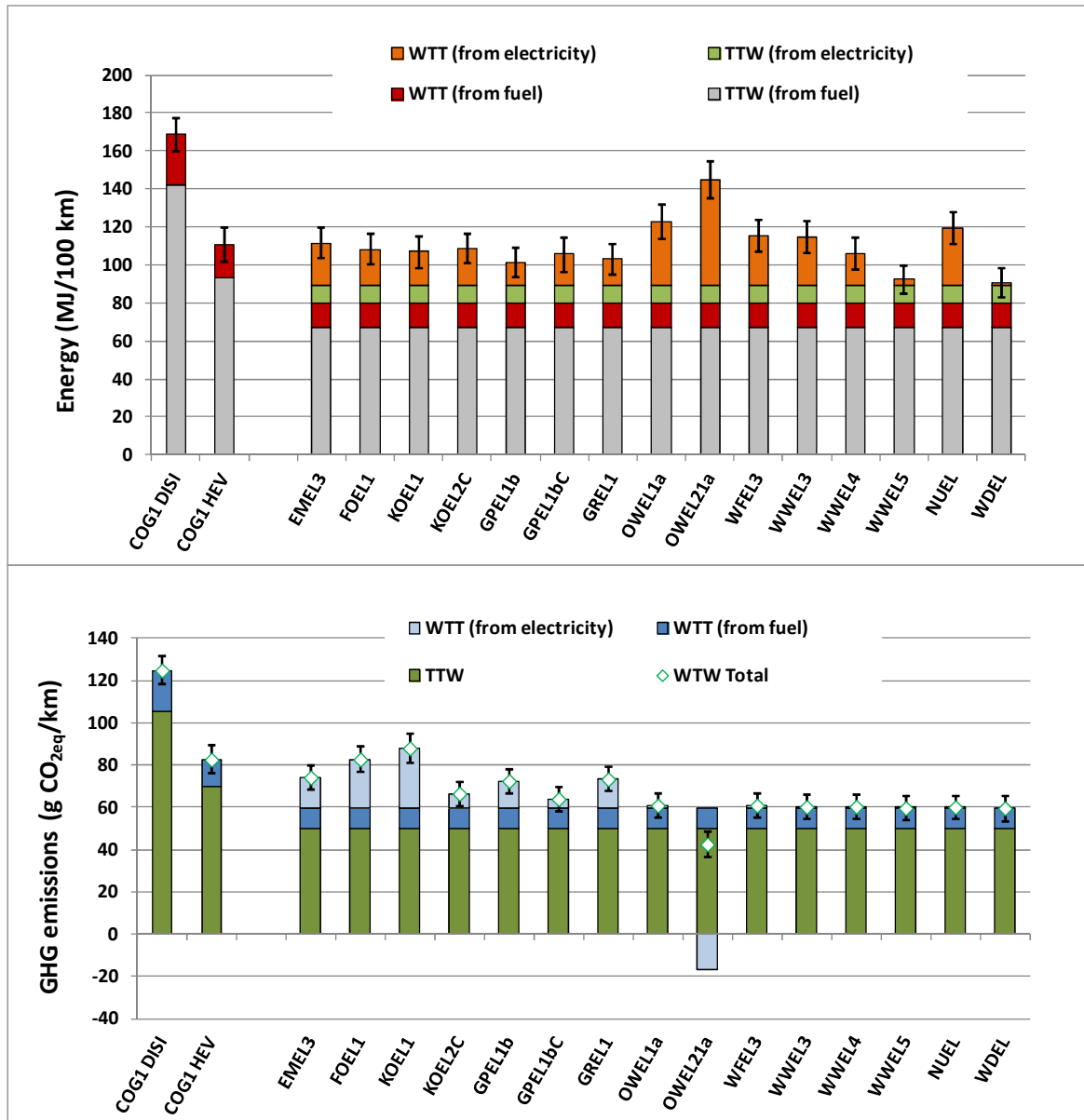

Key to electricity pathway codes

<i>Base vehicle fuel</i>	
COG1	Conventional gasoline
<i>Electricity</i>	
EMEL3	EU-mix (LV)
FOEL1	Heavy fuel oil, conventional power plant
KOEL1	Hard coal (EU-mix), conventional power plant
KOEL2C	Hard coal (EU-mix), IGCC + CCS
GPEL1b	Piped natural gas (4000 km), CCGT
GPEL1bC	Piped natural gas (4000 km), CCGT + CCS
GREL1	LNG, CCGT
OWEL1a	Municipal waste (closed digestate storage), small CHP
OWEL21a	Manure (closed digestate storage), small CHP
WFEL3	Wood (farmed), small conventional
WWEL3	Wood (waste), small conventional
WWEL4	Wood (waste), cofiring coal plant
WWEL5	Black liquor
NUEL	Nuclear
WDEL	Wind

The same figure can be constructed for the 2020+ Diesel PHEV and looks similar. Comparing **the results for the gasoline and diesel PHEVs** it is seen that the Diesel PHEV is slightly more efficient in terms of energy consumption and GHG emissions (see also **Figure 4.3-4a/b**).

REEVs

The selection of electricity pathways used for the PHEV above is used in **Figure 4.3-2** for a 2020+ SI REEV (here again the same figure with CI REEV would look similar).

Compared with the PHEV, the REEV derives a higher percentage of its driving power from mains electricity, so the differences between electricity sources come out more clearly. It can be seen that GHG emissions are lower than conventional vehicles for EU-mix electricity, for natural gas and for wind and other renewables, but if the marginal electricity comes from coal, the GHG emissions are no better than for a gasoline vehicle.

Figure 4.3-2a/b WTW total energy expended and GHG emissions for SI-REEV 2020+ configuration using conventional gasoline (ICE operation) and various electricity pathways

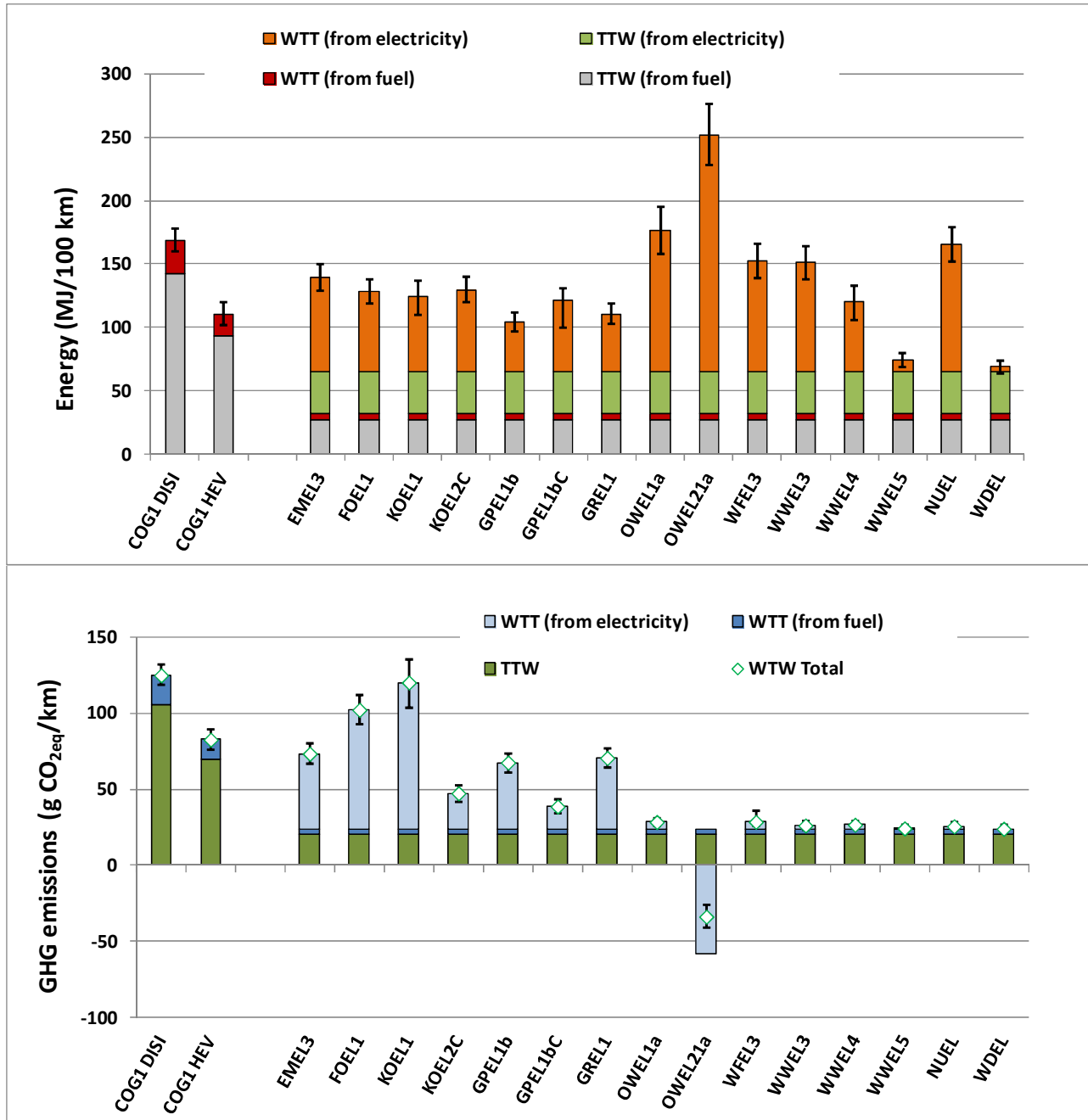

BEVs

The selection of electricity pathways used for the PHEV above is used in **Figure 4.3-3a/b** for a 2020+ BEV..

The results are similar to those for the REEV, with reductions in GHG emissions compared with conventional ICE vehicles, except in the case where coal electricity is used. For electricity from wind (and other renewables) GHG emissions are zero or close to zero.

Figure 4.3-3a/b Total energy expended and GHG emissions for BEV 2020+ configuration using various electricity pathways

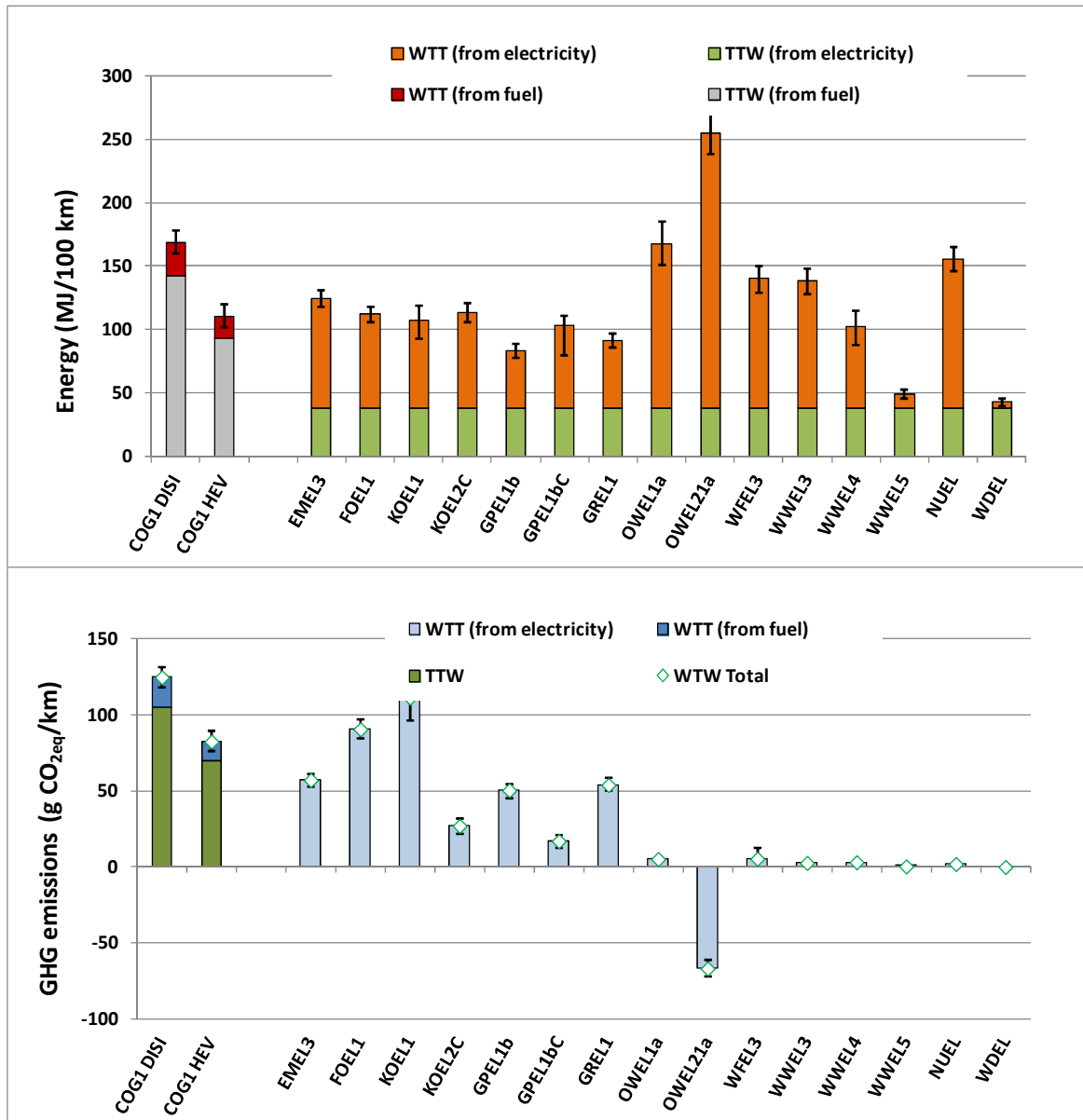

Comparing xEVs

Figure 4.3-4a/b shows the WTW energy and GHG balance for the xEVs and a smaller selection of electricity generation pathways.

Figure 4.3-4a/b WTW total energy expended and GHG emissions for all EV configurations using selected electricity pathways

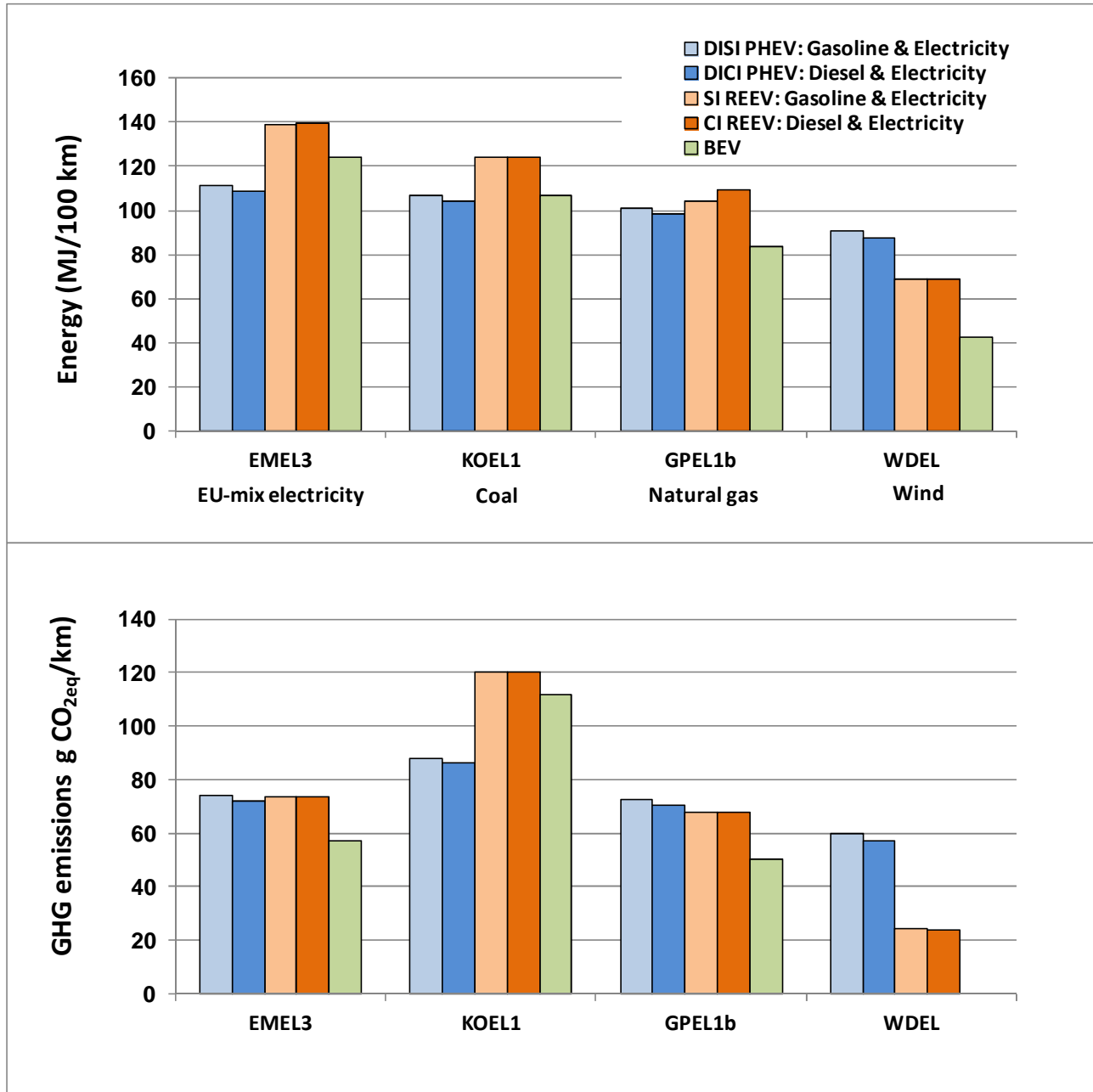

The proportion of electricity used relative to liquid fuel increases moving from PHEV through REEV to BEV. The energy use and GHG emissions are influenced by the source of the electricity used, but also by the efficiency of the vehicle. Emissions for the BEV powered by wind electricity are effectively zero..

- Many electricity production routes exist and when used in xEVs the energy and GHG balances of these vehicles are critically dependent on the pathway selected.
- The WTW energy requirements for the xEVs are similar for several electricity generation pathways whereas the GHG balances of these vehicles show a greater variability.

4.4 Fuel combinations in PHEV and REEV

This section illustrates in a more general way how GHG emissions vary depending on the carbon footprint of electricity production and the type of liquid fuel used. The results are illustrated for some SI 2020+ configurations. Similar figures can be drawn for CI fuel/powertrain configurations.

In **Figure 4.4-1** a comparison is given for the gasoline vehicles DISI, DISI PHEV and SI REEV, the latter two vehicles also using electricity for parts of their propulsion. The use of conventional gasoline results in a non-zero starting point in the diagram whereas the BEV function has its origin at zero if carbon free electricity is used.

An interesting feature is seen in **Figure 4.4-1** as the carbon footprint of electricity increases. The DISI PHEV function is crossing the BEV and SI REEV results and for high carbon intensities of the electricity the PHEV vehicle emits less GHG than the others. This can be explained by the dominant electric mode of driving by the BEV and REEV.

Figure 4.4-1 WTW GHG emissions of various xEVs as a function of the electricity GHG intensity compared to DISI gasoline vehicles (2020+ vehicles)

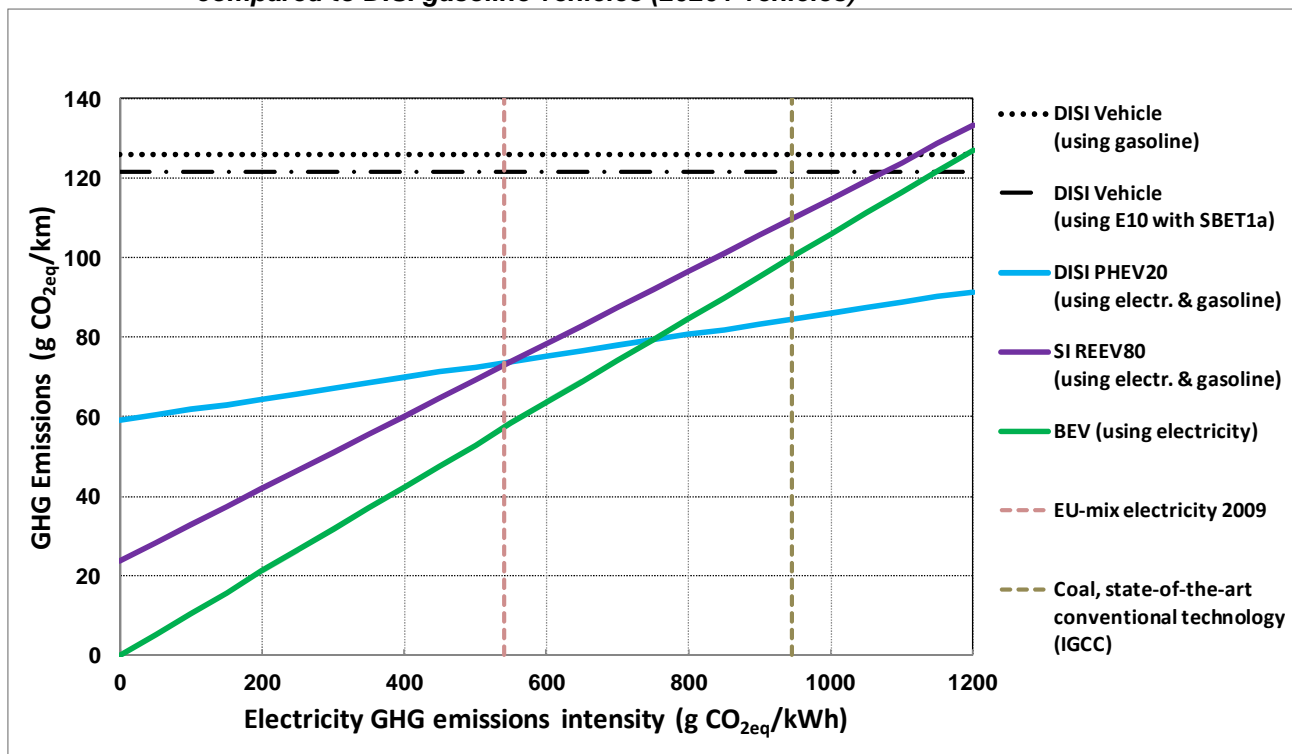

Where the GHG emissions from electricity production are low, xEVs show lower GHG emissions than conventional gasoline or diesel vehicles, emissions reducing as a greater proportion of electricity is used for propulsion (PHEV - REEV - BEV). Where the GHG emissions from electricity generation are high, the PHEV offers lower GHG emissions than conventional vehicles, REEV or BEV, because of its lower use of electricity and its improved efficiency compared with conventional vehicles. This is primarily a function of the different assumed electric range (20km vs. 80km) rather than a differentiator between PHEV and REEV technology.

Figure 4.4-2 translates the previous figure into a reduction potential when compared to the 2020+ DISI vehicle. The GHG reduction potential for all three vehicles is of course high if the carbon intensity of the electricity is low.

Figure 4.4-2 GHG emission reduction potential of xEVs compared to gasoline DISI vehicles (2020+ vehicles)

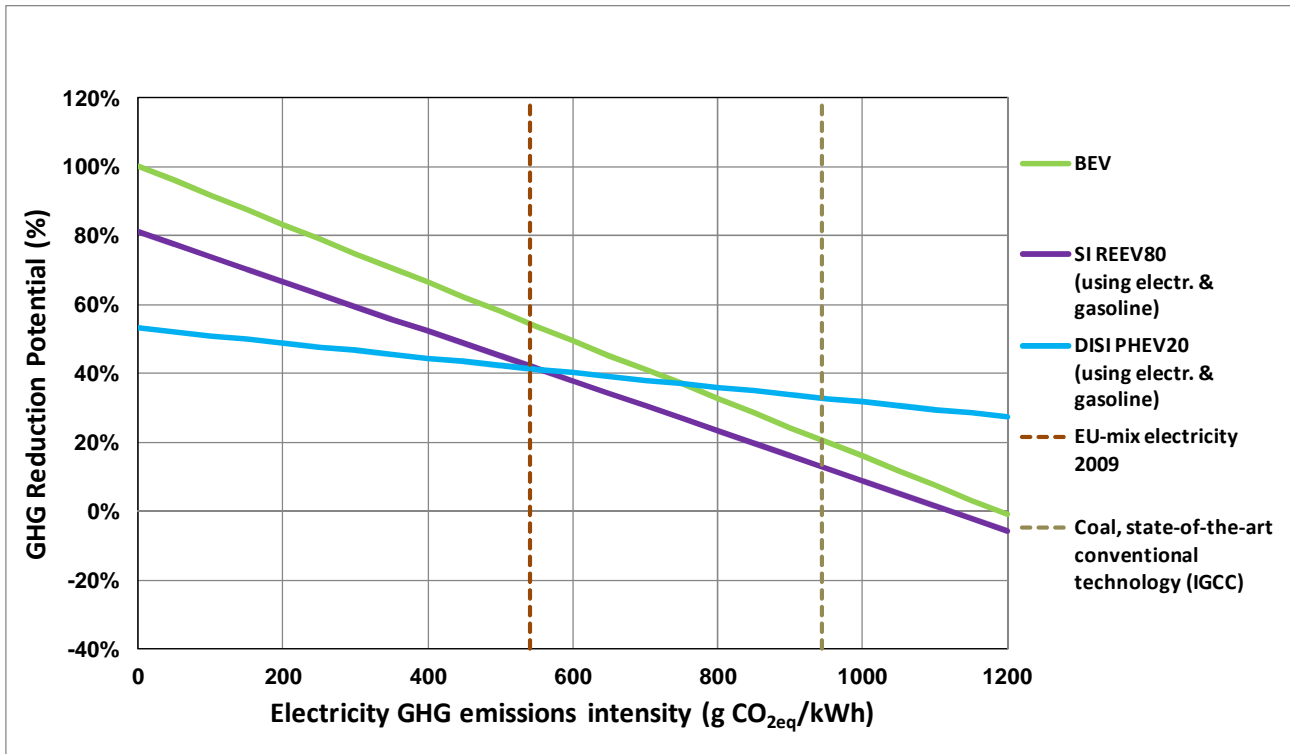

In **Figure 4.4-1** conventional (hydrocarbon) gasoline was used by the xEVs as liquid fuels. However, other liquid fuel options exist with reduced fossil carbon content specifically blends of gasoline containing ethanol or ETBE. We have illustrated the effect here using an E85 ethanol/gasoline blend where the ethanol was produced from sugar beet (pathway SBET1b, see section 3.4).

Figure 4.4-3 shows the results for the PHEV using conventional gasoline and a PHEV using E85. The area between the two lines shows the range for other gasoline/ethanol blends.

Figure 4.4-3 GHG emission for PHEV using gasoline and E85 compared to BEV and DISI vehicles (2020+ vehicles)

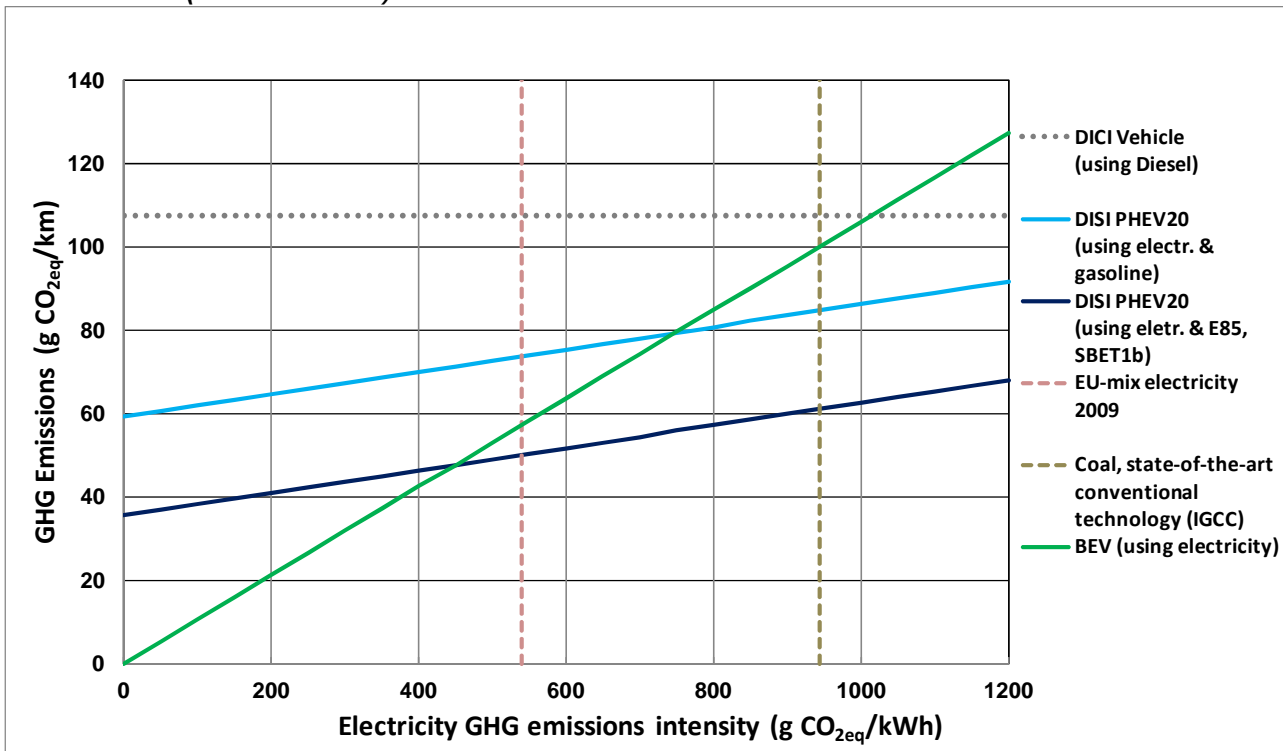

- There is a range of options for vehicles designed to use grid electricity ranging from battery vehicles (BEV) which use only electric power, to Range-Extender Electric Vehicles (REEV) and Plug-In Hybrids (PHEV) which in turn provide a greater proportion of their power from the ICE.
- While electric propulsion on the vehicle is efficient, the overall energy use and GHG emissions depend critically of the source of the electricity used.
- Where electricity is produced with lower GHG emissions, electrified vehicles give lower GHG emissions than conventional ICEs, with BEVs giving the lowest emissions
- Where electricity production produces high levels of GHG emissions, the PHEV20 configuration emits less GHG than the other xEVs. This is because it uses less electric driving than the BEV and REEV.
- The differences in performance between PHEV and REEV technologies are primarily a function of the different assumed electric range (20km vs. 80km) rather than a differentiator between technologies themselves.

5 Fuel Cell Vehicles (FCEV) and Hydrogen

Hydrogen as a transportation fuel conjures up images of quiet, efficient, non-polluting vehicles and is therefore the focus of much attention. Reality is of course more complex and both the desirability to develop hydrogen as a road fuel and the way to get there need to be considered very carefully.

As the lightest of all gases, hydrogen has a low energy density and must be stored either compressed at very high pressures (currently 700bar) or liquefied at very low temperatures or in cryo-compressed hybrid tanks. These tank technologies allow a meaningful quantity of hydrogen on-board the vehicle for a required driving range. This presents significant challenges particularly for mobile applications.

Hydrogen is not a primary energy source but an energy vector. Although it is the most widespread element in the universe, free hydrogen does not occur in nature. It needs to be “extracted” from compounds such as hydrocarbons and of course water, at the cost of an energy input. This results in emissions of GHG to varying degrees depending on the source of that energy and the specific pathway chosen.

There are many possible routes to a “hydrogen alternative” leading to a very wide range of energy usage and GHG emissions. If the WTW approach is required when considering any transport fuel, it is absolutely essential for hydrogen where a large part of the energy usage and all of the GHG emissions occur at the production stage.

5.1 Hydrogen fuelled Vehicles

PISI internal combustion engines can be adapted to burn hydrogen. The high temperature combustion process results in the production of traces of NO_x. The maximum efficiency of these hydrogen ICEs is expected to be very close to the best 2010 Diesel engines. Although more advanced and efficient hydrogen engines can be envisaged, the same technologies can also be applied to gasoline and natural gas engines. The real efficiency breakthrough comes from Fuel Cells.

Fuel cells (FC) are chemical converters fed by gaseous hydrogen and ambient air, producing DC voltage/current, heat and water. Their principal attraction is their high energy conversion efficiency compared to thermal engines. If fuelled directly by hydrogen they emit no pollutants at the point of use, and so have true zero emission (ZEV) capability.

As an alternative to a hydrogen infrastructure and the range of issues and challenges it raises, hydrogen generation from a liquid fuel on-board the vehicle has been proposed. Such vehicles would be equipped with small scale reformers, able to convert gasoline, methanol, naphtha or even diesel fuel into hydrogen which is then directly fed to the fuel cell. These vehicles represent a completely different approach combining on-board hydrogen production and usage. The advantages of avoiding the hydrogen distribution infrastructure and on-board storage are counterbalanced by the much greater complexity of the vehicle, the challenge of building a reformer that is small and efficient, the control system involving the reformer, the fuel cell and their interface, and the additional vehicle mass. Using “normal” liquid fuels, these vehicles also emit CO₂ and other pollutants.

During recent years the automotive industry has concentrated their R&D on FC vehicles and lesser towards H₂-ICEs. The on-board reforming approach has not been followed anymore. Hence, this version of the WTW report only considers FC vehicles. The configurations of the two FC vehicle options analysed in the study are schematically represented below (for details see **TTW report**, section 5 & 6). Technical data is displayed in **Table 5.1**.

Table 5.1 Data for the FCEV, the REEV-FC and the BEV

xEVs Configurations 2020+		FCEV	REEV80 FC	BEV
		Hydrogen	Hydrogen	Electricity
Powertrain				
Fuel Cell Power	kW	55	30	-
Fuel Cell system mass	kg	109	79	-
Transmission mass	kg	10	10	10
<i>Powertrain mass change</i> ¹	<i>kg</i>	<i>-66</i>	<i>-96</i>	<i>-175</i>
Storage System				
Fuel Tank Capacity	L			-
Tank System mass ²	kg	80	80	-
Fuel mass	kg _{H2}	4	4	-
<i>Storage System mass change</i> ¹	<i>kg</i>	<i>+43</i>	<i>+43</i>	<i>-41</i>
Electric Components				
e-Motor mass ³	kg	55	55	51
e-Motor power: peak/cont.	kW	70 / 45	72 / 36	70 / 37
Battery mass ³	kg	26	90	175
Battery Maximum Power	kW	30	90	90
Battery Energy (Total / Available)	kWh	1,0 / 0,5	10,7 / 8,2	22,1 / 18,4
xEV wiring harness mass	kg	20	20	20
eComponents mass change ¹	<i>kg</i>	<i>+101</i>	<i>+165</i>	<i>+246</i>
Vehicle				
Curb weight (incl. driver, 90% fuel)	kg	1278	1312	1230
Performance mass: Curb + 125kg	kg	1403	1437	1355
Gross vehicle mass: Curb + 550kg	kg	1828	1862	1780
1) Reference is the 2020+ DISI vehicle				
2) Same tank system mass is assumed for the CGH ₂ and cCGH ₂				
3) Masses for e-motor and battery include housing, power electronics and cooling system.				

5.1.1 Fuel Cell Electric Vehicle (FCEV)

Figure 5.1.1-1 shows the schematics of the powertrain system layout of the configuration featuring a fuel cell system as the dominant source of propulsion, the FCEV. The drivetrain consists of a one-gear transmission. This layout was simulated using two hydrogen tank systems: a version storing hydrogen as a compressed gas at 700bar pressure (CGH₂) and the other option was a combined cryo-compressed system (CCH₂).

The specific weight of both CGH₂ and CCH₂ tank systems are estimated to be 23kg/kgH₂ for 2010 and 20kg/kgH₂ for 2020+. In both 2010 and 2020+ the fuel tank capacity is assumed to be 4kg which gives a driving distance well above the 500km minimum criteria. Due to a negligible mass difference between CGH₂ and CCH₂ technology for the targeted tank capacity of 4kg H₂ only one simulation run for each FCEV 2010 and FCEV 2020+ configurations is done based on a generic tank system.

Figure 5.1.1-1 Fuel Cell powertrain architecture

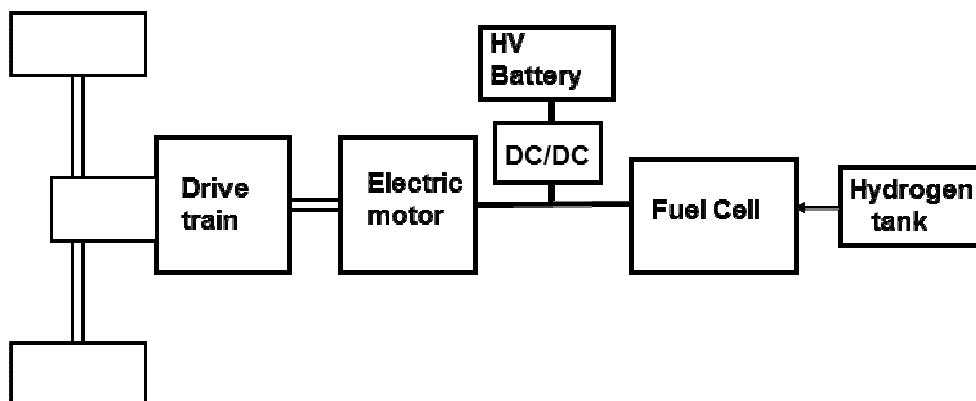

The operational strategy for Fuel Cell driven configurations is optimized to operate the Fuel Cell at a maximum efficiency within a suitable range of the battery SOC. This control logic consists of four different operation modes defined as a function of the battery SOC and the required electric power (for details see *TTW report, section 3.4*).

Figure 5.1.1-2 shows the Fuel Cell System Efficiency characteristics for the 2020+ configurations in comparison to the 2010 FCEV characteristic, given in percent of the Fuel Cell System maximum power. 2020+ efficiencies are defined by the EUCAR working group and are based on current research and development projects.

Figure 5.1.1-2 Fuel cell system efficiencies

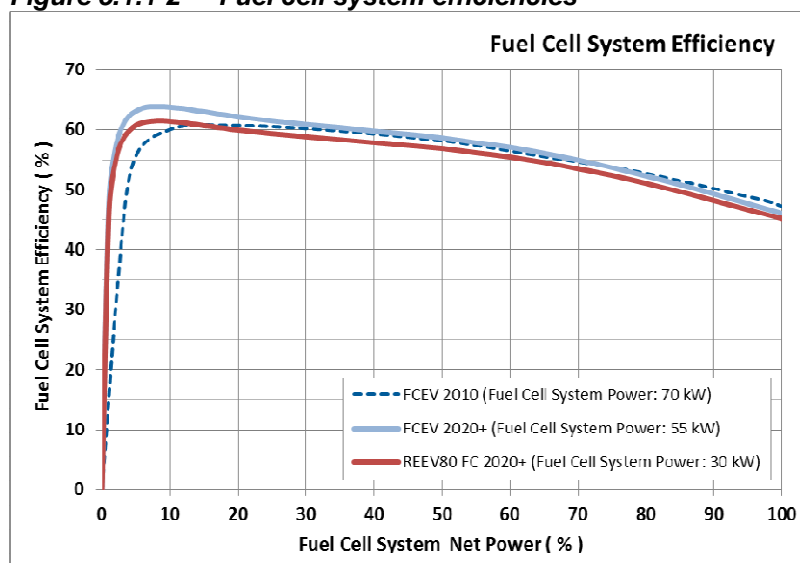

The FCEV configurations considered in this study feature similar operational strategies as defined in **Table 4.1** for the xEVs. As for the other vehicles, vehicle technologies also improve towards 2020+ for the FCEV delivering considerable efficiency gains.

5.1.2 Range extended electric vehicle – FC (REEV-FC)

The major differences between the FCEV and the REEV-FC are

- Size of the HV battery (1kWh for the FCEV while ~11kWh for the REEV-FC to achieve 80km electric-only driving range)
- plug-in functionality for the REEV-FC vehicle
- Positioning of the DC/DC converter (power controller)

For each layout the positioning of the DC/DC converter is optimized towards the most efficient power supply for driving: In the case of the FCEV (mainly operating via the Fuel Cell) the DC/DC converter is directly connected to the HV battery. In the case of the REEV FC (mainly operating via the HV battery) the DC/DC

converter is directly connected to the Fuel Cell. Therefore the Fuel Cell System efficiency of the REEV FC (including a DC/DC converter) is slightly reduced in comparison to the efficiency of the FCEV (see **Figures 5.1.1-1** and **5.1.2** for the different powertrain architectures and **Figure 5.1.12** for an efficiency comparison).

Figure 5.1.2 REEV -FC powertrain architecture

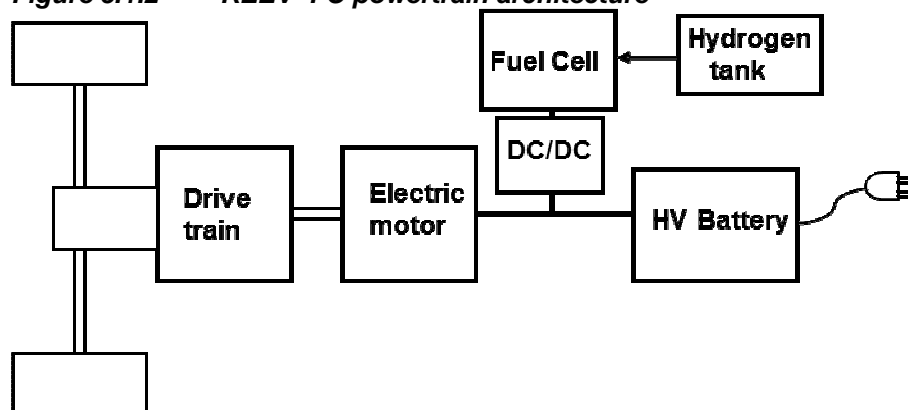

5.2 Hydrogen production routes and potential

One of the perceived merits of hydrogen is that it can in principle be produced from virtually any primary energy source. This can be done either via a chemical transformation process generally involving decarbonisation of a hydrocarbon or organic feedstock and splitting of water (in the foregoing we refer to “thermal” hydrogen) or from electricity via electrolysis of water.

Hydrogen is already produced in significant quantities today mostly for industrial applications. Oil refineries, in particular, are large hydrogen consumers for hydrodesulphurisation of various streams such as gasoils and heavy oil conversion processes. The bulk of industrial hydrogen is produced via steam reforming of natural gas.

Direct solar energy can also, in principle, be used to produce hydrogen either by thermal splitting of water or electrolysis through photovoltaic electricity. The development of the thermal splitting process is in its infancy while photovoltaic electricity is not expected to be viable at very large scale within the timeframe of this study. We have therefore not included these options.

5.2.1 Thermal production

The most widespread hydrogen production process is steam reforming of natural gas (essentially methane). The catalysed combination of methane and water at high temperature produces a mixture of carbon monoxide and hydrogen (known as “syngas”). The water gas shift (“CO-shift”) reaction then combines CO with water to form CO₂ and hydrogen. The process is technically and commercially well-established and natural gas is a widely available and relatively cheap feedstock. Steam reforming of heavier hydrocarbons is also possible but little applied, if at all, in practice because the process equipment is more complex and the potential feedstocks such as LPG or naphtha have a higher alternative value. Existing reformers are mostly large industrial plants but small scale prototypes have been developed.

Syngas can also be produced by partial oxidation of a carbonaceous feedstock in the presence of water. This can be applied to a wide range of materials, in particular heavy feedstocks such as oil residues and coal, as well as biomass feeds such as wood. The front end of the process is essentially the same as for the manufacture of synthetic liquid fuels. The synthesis section is replaced by the CO-shift step. Small scale wood gasifiers for electricity production have been developed at the pilot plant stage and could conceivably be adapted for small scale hydrogen production.

In these processes and particularly for heavy feedstocks, the bulk of the hydrogen comes from water, the carbon in the feed providing the energy required for splitting the water molecule.

Reformers and gasifiers produce CO₂ at a single location and, when using oxygen rather than air, in a virtually pure form. Large scale installations may offer a viable platform for possible CO₂ capture and sequestration projects).

5.2.2 Electrolysis

Electrolysis uses electricity to split the water molecule. This is a well-established technology both at large and small scale. Interest in large scale hydrogen production may result in improvements in terms of efficiency and cost. One particularly promising development route is high pressure electrolyzers (higher production pressure means less compression energy for storage). The use of electricity as the energy vector to produce hydrogen opens the door to the use of a large variety of primary energy sources including fossil and biomass but also wind energy and of course nuclear.

5.2.3 Hydrogen potential

A lot of hydrogen can theoretically be produced. In practice though and in view of the availability of both feedstock and technology, only natural gas reforming provides a short term avenue for flexible large scale hydrogen production. The coal route requires large scale, costly plants with major financing and public acceptance issues and needs more research. Biomass is of course an option but of a limited nature particularly as they are many other potential uses for biomass (see section 6). The same constraint applies to wind energy which can be used directly as electricity. Only in “stranded wind” situations where electricity from wind could not practically be fed into the grid, would hydrogen production give more benefit than electricity generation. Nuclear energy is potentially a very large supplier of energy with currently low GHG emissions, and could contribute to the supply of hydrogen. However, its development opens societal, political as well as technical issues (uranium ore availability & extraction process), which is not discussed in this report.

5.3 Distribution and refuelling infrastructure

As mentioned in the previous section, hydrogen production can be envisaged either centrally in a large plant or, in a number of cases, locally in a small plant serving one or a few refuelling sites. This “on-site” option is plausible for natural gas reformers, wood gasifiers and electrolyzers.

Although central plants tend to be more efficient, the downside is the need to transport hydrogen rather than e.g. natural gas or wood. Technologies are available for this and are in use in the industrial hydrogen transport networks in existence in Europe and other parts of the world. Hydrogen is commonly transported in gaseous form in pipelines and road pressurised cylinders or as a liquid in cryogenic tanks (mostly by road).

The development of a large scale hydrogen pipeline distribution network is likely to require a European regulatory framework to ensure safety and public acceptance. Existing hydrogen pipelines in Europe link major industrial sites over relatively short distances and would be of limited use in this respect.

For small volumes, transport of gaseous hydrogen using tube trailers is feasible, but the mass of the containers is very high compared with the amount of hydrogen transported. It has been estimated that up to 19 trucks might be needed to deliver the amount of energy delivered by one single gasoline truck.

Even in liquid form, hydrogen remains a low-density energy carrier with implications on the options for road distribution channels (as an illustration supplying a hydrogen refuelling site might take five times as many trucks as is the case for conventional fuels).

This study includes options for pipeline distribution (over an area typical of a major urban community), road transport in pressurised cylinders or in liquid form in cryogenic tanks, as well as distributed hydrogen generation schemes that would reduce the transport problems

For the refuelling stations, considerations similar to those applicable to CNG apply. Compressed hydrogen dispensers operating at pressures of either 35 or 70MPa have been built and tested, demonstrating safe and reliable refuelling in a public environment (we have assumed that vehicles are refuelled at 70 MPa). For liquid hydrogen, there is now a wide consensus that storing hydrogen in this form on-board a vehicle is not a reasonable approach due to losses via hydrogen boil off. However, some vehicle manufacturers are considering cryo-compression i.e. pressurised tanks which can store hydrogen at cryogenic temperatures (e.g. at 30 MPa and 60 K). This has the advantage of reducing the rate of evaporation when the vehicle is idle. We

have assumed that both technologies, 70MPa compressed gaseous hydrogen and cryo-compressed hydrogen will be used.

5.4 Energy and GHG balances

We have considered a large number of alternative hydrogen pathways and the reader may refer to Appendix 1 of this report or to the **WTT and TTW reports** for details. In this section we only discuss some of the options to illustrate the most important findings. **Figure 5.4-1** illustrates the diversity of routes and the wide range of energy consumption and GHG emissions (the data points for conventional diesel in a 2020 DI CI vehicle and CNG in a 2020 DISI vehicle are also shown for reference).

Figure 5.4-1 WTW energy expended and GHG emissions for 2020+ FCEV and various hydrogen pathways

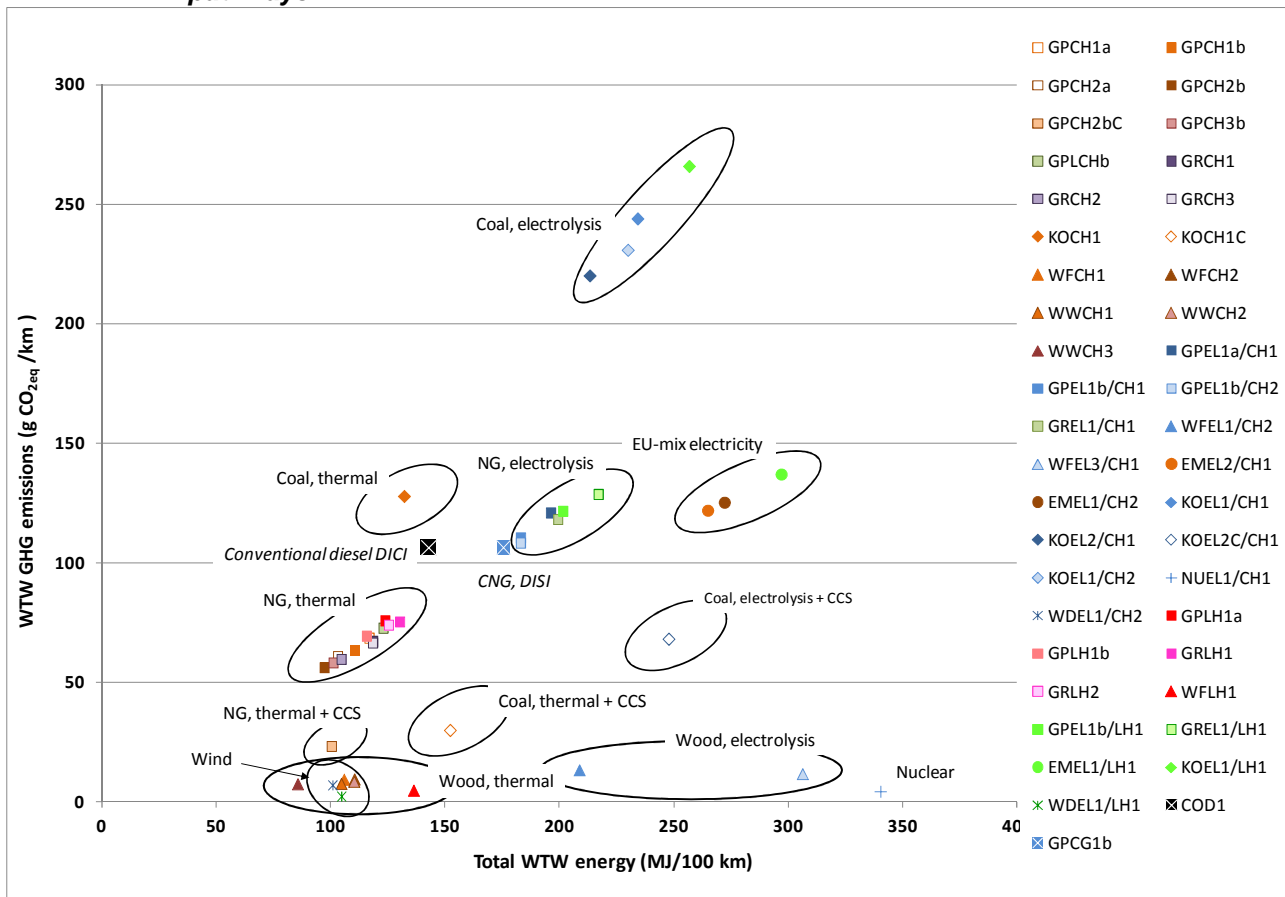

Key to pathway codes

Compressed hydrogen (thermal)		
GPCH1a	NG 7000 km, on-site reforming	C-H2 NG
GPCH1b	NG 4000 km, on-site reforming	C-H2 NG
GPCH2a	NG 7000 km, Central reforming, Pipeline transport	C-H2 NG
GPCH2b	NG 4000 km, Central reforming, Pipeline transport	C-H2 NG
GPCH3b	NG 4000 km, Central Reforming, Road transport	C-H2 NG
GPLCHb	NG 4000 km, Cen Reforming, Liquefaction, Road transport, Vap/compression	C-H2 NG
GRCH1	LNG, on-site reforming	C-H2 NG
GRCH2	LNG, Central reforming, Pipeline transport	C-H2 NG
GRCH3	Remote NG, methanol synthesis, sea and local transport, on-site reforming	C-H2 NG
KOCH1	Coal EU-mix, Cen gasification, Pipeline transport	C-H2 Coal
KOCH1C	Coal EU-mix, Cen gasification + CCS, Pipeline transport	C-H2 Coal
WFCH1	Farmed Wood, on-site gasification	C-H2 F Wood
WFCH2	Farmed Wood, Central gasification, Pipeline transport	C-H2 F Wood
WWCH1	Waste Wood, on-site gasification	C-H2 W Wood
WWCH2	Waste Wood, Central gasification, Pipeline transport	C-H2 W Wood
WWCH3	Waste Wood, via Black Liquor	C-H2 W Wood
Compressed hydrogen (electrolysis)		
GPEL1a/CH1	NG 7000 km, CCGT, on-site electrolysis	C-H2 NG
GPEL1b/CH1	NG 4000 km, CCGT, on-site electrolysis	C-H2 NG
GPEL1b/CH2	NG 4000 km, CCGT, central electrolysis, pipeline transport	C-H2 NG
GREL1/CH1	LNG, CCGT, on-site electrolysis	C-H2 LNG
WFEL1/CH2	Farmed Wood, 200 MW gasification, CCGT, Central electrolysis, pipeline transport	C-H2 F Wood
WFEL3/CH1	Farmed Wood, Conventional power plant, on-site electrolysis	C-H2 F Wood
EMEL2/CH1	Elec EU-mix (MV), on-site electrolysis	C-H2 EU-mix elec
EMEL1/CH2	Elec EU-mix (HV), central electrolysis	C-H2 EU-mix elec
KOEL1/CH1	Coal EU-mix, conventional, on-site electrolysis	C-H2 Coal
KOEL2/CH1	Coal EU-mix, IGCC, on-site electrolysis	C-H2 Coal
KOEL2C/CH1	Coal EU-mix, IGCC + CCS, on-site electrolysis	C-H2 Coal
WDEL1/CH2	Wind electricity, central electrolysis, Pipeline transport	C-H2 Wind
NUEL1/CH1	Nuclear electricity, on-site electrolysis	C-H2 Nuclear
Liquid / cryo-compressed hydrogen (thermal)		
GPLH1b	NG 7000 km, Cen Reforming, Liquefaction, Road transport	Cc-H2 NG
GPLH1a	NG 4000 km, Cen Reforming, Liquefaction, Road transport	Cc-H2 NG
GRLH1	Reforming and liquefaction at source, sea and local transport	Cc-H2 NG
GRLH2	LNG, Central reforming, Liquefaction, Road transport	Cc-H2 NG
WFLH1	NG 4000 km, CCGT, Cen Ely, Liq, Road	Cc-H2 F Wood
Liquid / cryo-compressed hydrogen (electrolysis)		
GPEL1b/LH1	LNG, Ely	Cc-H2 NG
GREL1/LH1	F Wood, 200 MW gasif, CCGT, Cen Ely, Liq, Road	Cc-H2 NG
EMEL1/LH1	Elec EU-mix (HV), Central electrolysis, Liquefaction, Road transport	Cc-H2 EU-mix elec
KOEL1/LH1	Coal EU-mix, conventional power plant, Central Electrolysis, Liquefaction, Road transport	Cc-H2 Coal
WDEL1/LH1	Wind electricity, Central Electrolysis, Liquefaction, Road transport	Cc-H2 Wind

Clearly, from an energy and GHG point of view, there are favourable and unfavourable ways of producing hydrogen. GHG reduction tends to be at the cost of extra energy although the high efficiency of the fuel cells can compensate for the high hydrogen production energy. The electrolysis routes whereby primary energy is first turned into electricity and then electricity into hydrogen are energy intensive. Even when combined with an efficient converter such as a fuel cell, the energy consumption remains higher than for conventional fuels and powertrains. Pathways involving liquid hydrogen are slightly less favourable than the equivalent with compressed hydrogen.

- *Many potential hydrogen production routes exist and the energy and GHG balances are critically dependent on the pathway selected.*

Hydrogen produced thermally from natural gas fares better than diesel and CNG on both energy and GHG emissions. The application of CCS would further improve the picture. There would, however, be no point in producing hydrogen via electrolysis using electricity from natural gas as the resultant routes would be less GHG efficient than CNG. The same applies to EU-mix electricity.

Coal-based pathways can only compare favourably with the conventional routes if CCS technology is applied.

As would have been expected wood-based pathways show very low GHG emissions. Using wind electricity is also very favourable. However, when using renewable resources, one must not only consider the savings achievable when substituting a given fuel but also the savings that might be achieved by using the same resource to a different end (see also section 6).

Figure 5.4-2, -3, -4 and -5 show the results in more detail for compressed and cryo-compressed hydrogen and thermal and electrolysis respectively.

Figure 5.4-2a/b WTW total energy expended and GHG emissions for 2020+ FCEV using compressed hydrogen via thermal process pathways

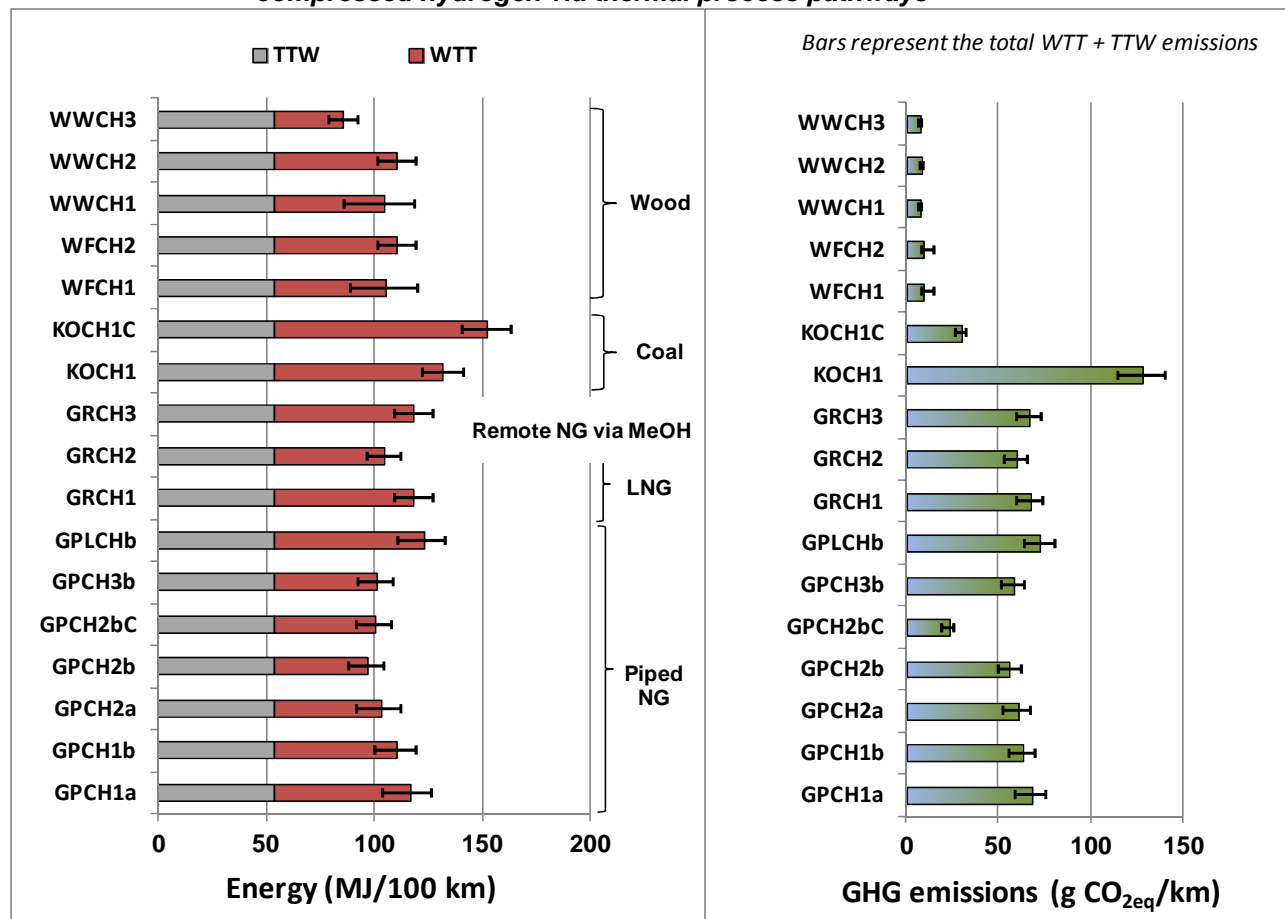

The source of natural gas plays a role through the transportation energy to deliver gas to Europe.

Natural gas reforming is more efficient when carried out centrally in a large plant (GPCH2), where waste energy can be recovered to produce electricity, rather than in a small local or on-site plant (GPCH1) where this is not practical. In energy terms the contribution of hydrogen transport to the total is minor.

Gasification processes are less energy-efficient than natural gas reforming because of the nature of the feedstock. Somewhat surprisingly the small scale wood (WFCH1) process is slightly more efficient than the large scale equivalent (WFCH2). This is due to a major difference in concept between the two schemes whereby the small scale system produces surplus heat and electricity whereas the large scale system is optimised for maximum hydrogen production (see also **WTT report**, section 3.4.10.1)

The GHG picture is very much consistent with the type of primary feedstock used.

For fuel cell vehicles and all other vehicle configurations considered in this version of the study, we predict improvements in fuel efficiency due to vehicle technologies such as lower weight reductions, lower rolling resistance and better aero dynamics. This means that at the 2020+ horizon, a fuel cell vehicle fuelled by hydrogen produced from natural gas should give GHG emissions 50% lower than a DISI gasoline vehicle.

- Hydrogen from NG used in a fuel cell at the 2020+ horizon has the potential to produce half the GHG emissions of a gasoline vehicle.

Figure 5.4-3a/b WTW total energy expended and GHG emissions for 2020+ FCEV using compressed hydrogen via electrolysis pathways

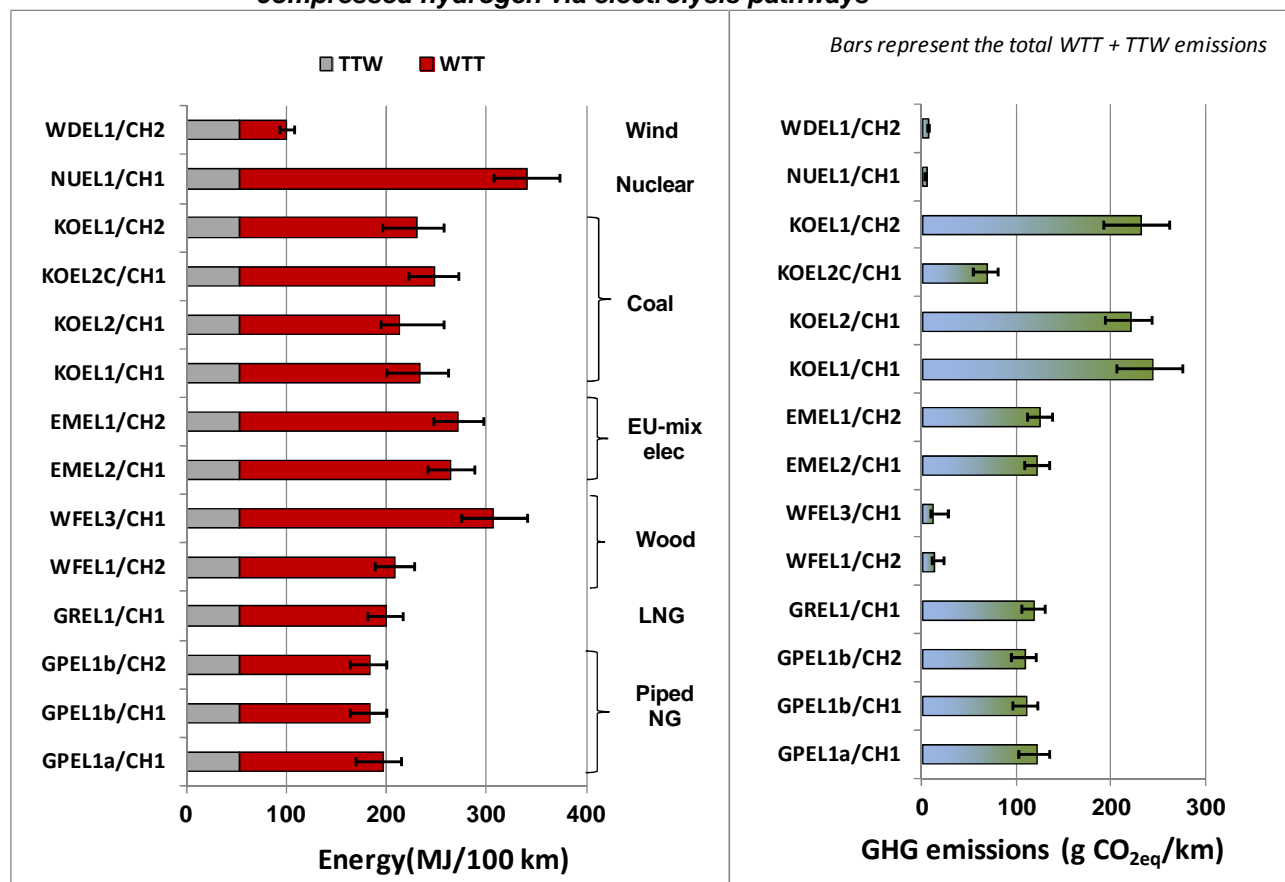

The energy and GHG balances are of course in line with the corresponding electricity pathways.

The energy balance for wind and nuclear energy are somewhat arbitrary. In the case of wind, it is common practice to consider the electricity output of the wind turbine as primary which explains the seemingly low energy requirement. For nuclear, the balance is based on the energy released by the nuclear reaction.

Compressed hydrogen produced by electrolysis from 4000km NG CCGT electricity or EU mix electricity produces similar GHG emissions to a gasoline DISI vehicle and twice as much GHG emissions as when the NG is converted by thermal processes to hydrogen.

Turning primary energy into electricity and then electricity into hydrogen is not an energy-friendly route. Even when combined with the most efficient converter, the energy consumption remains higher than for conventional fuels and powertrains.

Non-carbon routes obviously emit practically no GHG but, here again, the real issue for these is optimum use of limited resources (see section 6).

- Hydrogen from NG via thermal processes used in a fuel cell at the 2020+ horizon has the potential to produce half the GHG emissions of a gasoline vehicle.
- Using the same NG to produce electricity and then producing hydrogen by electrolysis gives no advantage over a gasoline vehicle

- Hydrogen from non-fossil sources (biomass, wind, nuclear) offers low overall GHG emissions.

Figure 5.4-4a/b WTW total energy expended and GHG emissions for 2020+ FCEV using cryo-compressed hydrogen via thermal process pathways

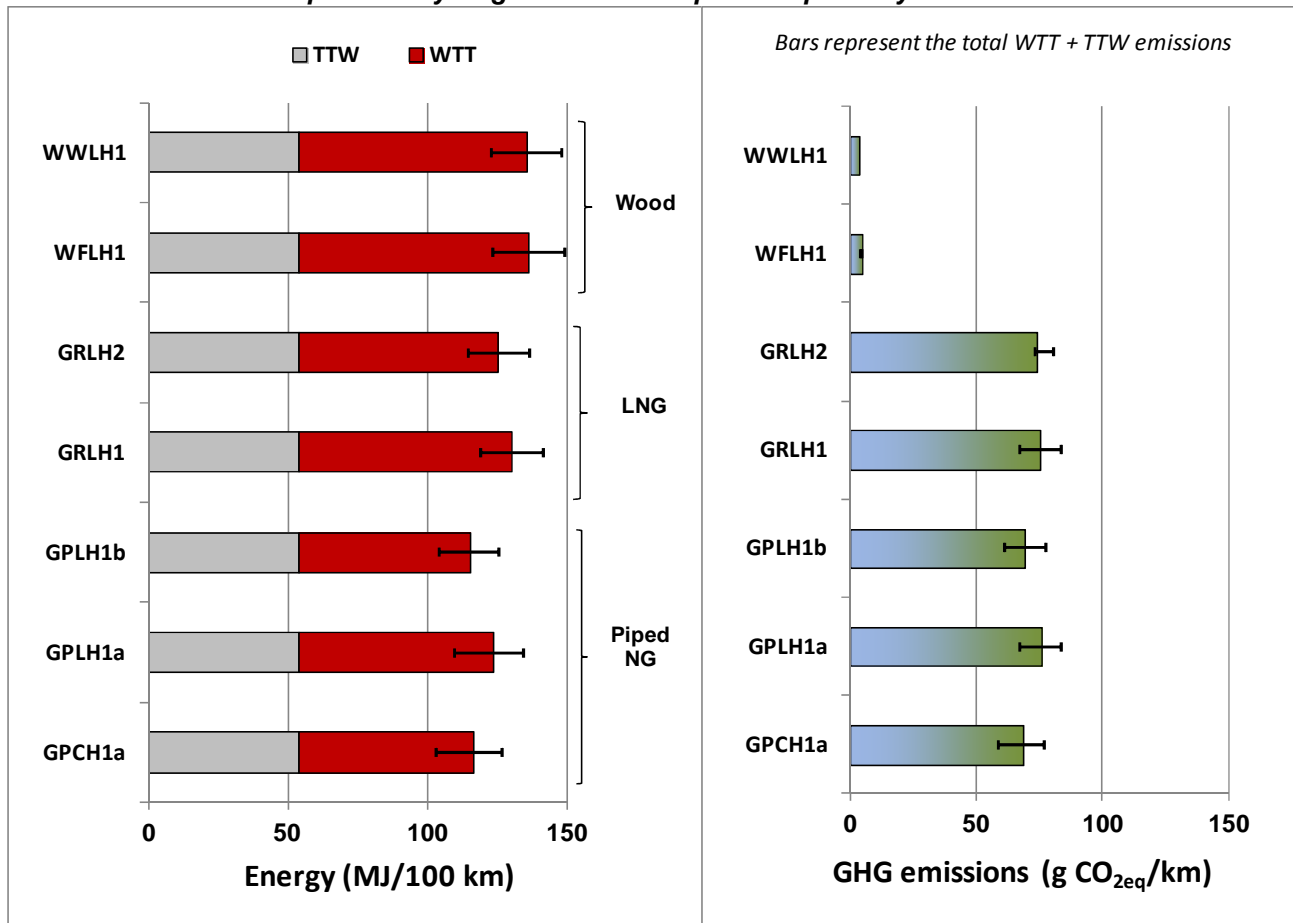
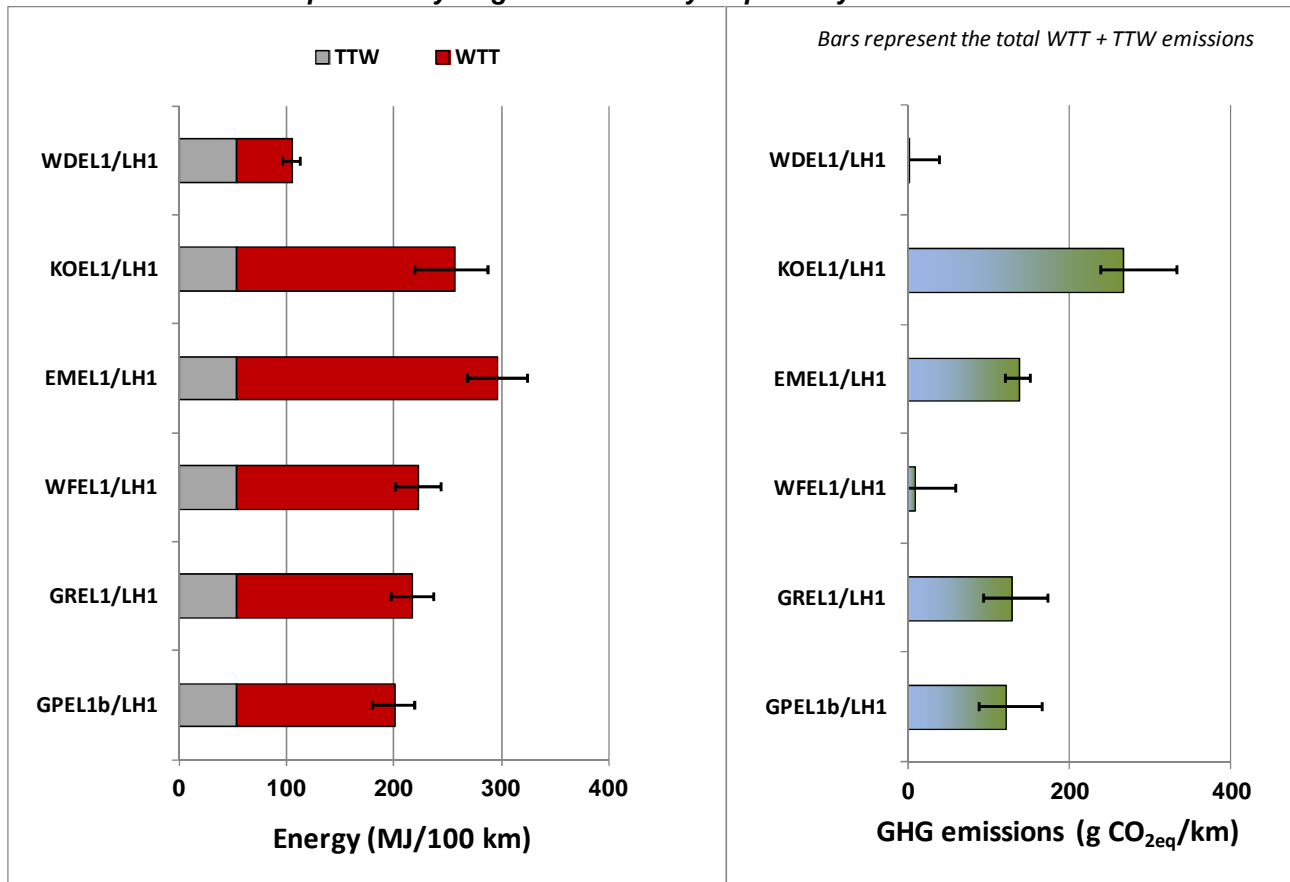

Figure 5.4-5a/b WTW total energy expended and GHG emissions for 2020+ FCEV using cryo-compressed hydrogen via electrolysis pathways



Figures 5.4-4a/b illustrates the small advantage (about 10%) of compressed hydrogen compared to the liquefaction / cryo-compression route. However, actual real world data from 70MPa hydrogen filling stations is currently being evaluated as the proposed standard [SAE J2601] allows several pre-cooling temperature ranges resulting in different filling times. There are indications that the currently mandatory pre-cooling might result in a need for higher additional energy demand. Hence, current assumptions regarding energy consumption and GHG emissions might change and future data might be more positive for a LH2-based infrastructure.

- Using hydrogen as a cryo-compressed fuel increases GHG emissions by about 10% compared to the compressed gaseous form with 70MPa.

Otherwise the remarks made for compressed hydrogen are also valid for the cryo-compression route.

Figure 5.4-6 WTW GHG emissions for 2020+ FCEV and REEV-FC using hydrogen via various pathways and EU mix electricity (for the REEV only)

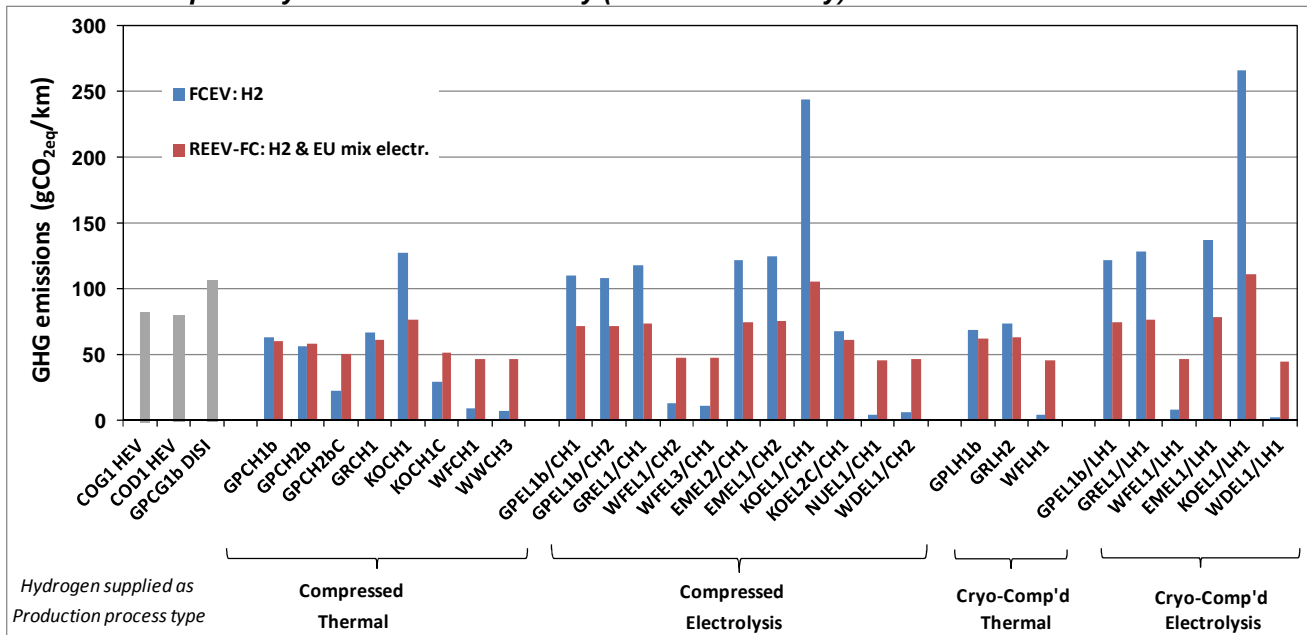

Figure 5.4-6 compares the results for the FCEV and the REEV-FC for several hydrogen production routes. The figures for the REEV-FC assume additional use of EU mix electricity which sets a lower limit for the GHG emissions that can be achieved. Where hydrogen is produced from renewable sources, FCEV emissions are lower than for the REEV-FC whereas the reverse is true if hydrogen is produced a higher carbon source such as coal.

5.5 Fuel combinations REEV-FC

Results for REEVs incorporating an ICE engine were presented in Section 4.4. For the future, the range extender could equally be a hydrogen fuel cell. In this case the picture is more complicated, because there are multiple pathways to produce both the electricity and the hydrogen used by the vehicle.

Figure 5.5-1 presents results for the REEV-FC when using combinations of H₂ and electricity. In addition, two options for the FCEV and the results for the BEV are included in the figure. A FCEV when using hydrogen from a natural gas pathway (here GPCH1b) emits around 62 g CO_{2eq}/km whereas using hydrogen from wind electricity and electrolysis (pathway WDEL1/CH2) is only emitting around 7 g CO_{2eq}/km. For the REEV-FC and the same sources for hydrogen the function in **Figure 5.5-1** starts off at around 20 g CO_{2eq}/km (GPCH1b), this value approaches zero the lesser the carbon footprint of hydrogen production is (WDEL1/CH2). The results for the BEV fall in between these two REEV-FC extremes for electricity GHG intensities below about 700 g CO_{2eq}/kWh.

Interestingly, three configurations (FCEV-NG, REEV-FC and BEV) are intersecting each other at around the GHG intensity of the 2009 EU mix electricity. For the configurations using (partly) electricity a high carbon footprint of the electricity resource is not favourable.

Figure 5.5-1 2020+ REEV-FC GHG emissions as a function of the electricity GHG intensity and hydrogen production pathway

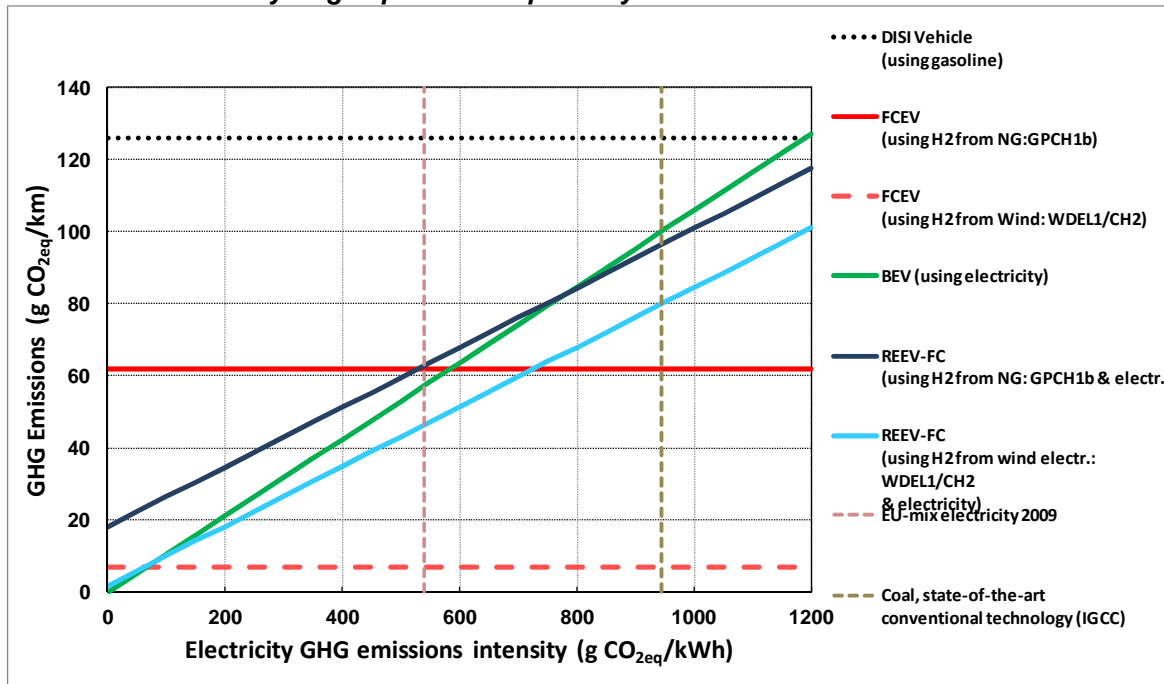

6 Alternative uses of primary energy resources

The previous sections present the energy and GHG performance for each pathway grouped by final fuel type with the main conclusions summarised at the beginning of this report.

This section extends the analysis, using the WTW data to consider the alternative question of how different uses of primary energy resources perform with respect to reducing or avoiding GHG emissions. All fuel resources, whether fossil or renewable are ultimately limited in availability, so it is important to know how they can be used in the most effective way.

Figure 6 shows the relationship between total WTW energy usage and WTW GHG emissions for all non-hydrogen pathways. The same information for hydrogen pathways is presented earlier in the report in Figure 5.4-1. The results are shown for 2020+ vehicles, except for conventional gasoline and diesel where the 2010 results are shown as well to act as a baseline: the dotted lines mark the performance of a 2010 gasoline vehicle. The energy figures include all energy, both fossil and renewable. In general, those options which have low GHG emissions have high total energy use. Although GHG emissions are of prime concern today, energy conservation and efficient use of energy resources are also desirable goals.

Figure 6 WTW energy expended and GHG emissions for non-hydrogen pathways (2020+ vehicles)

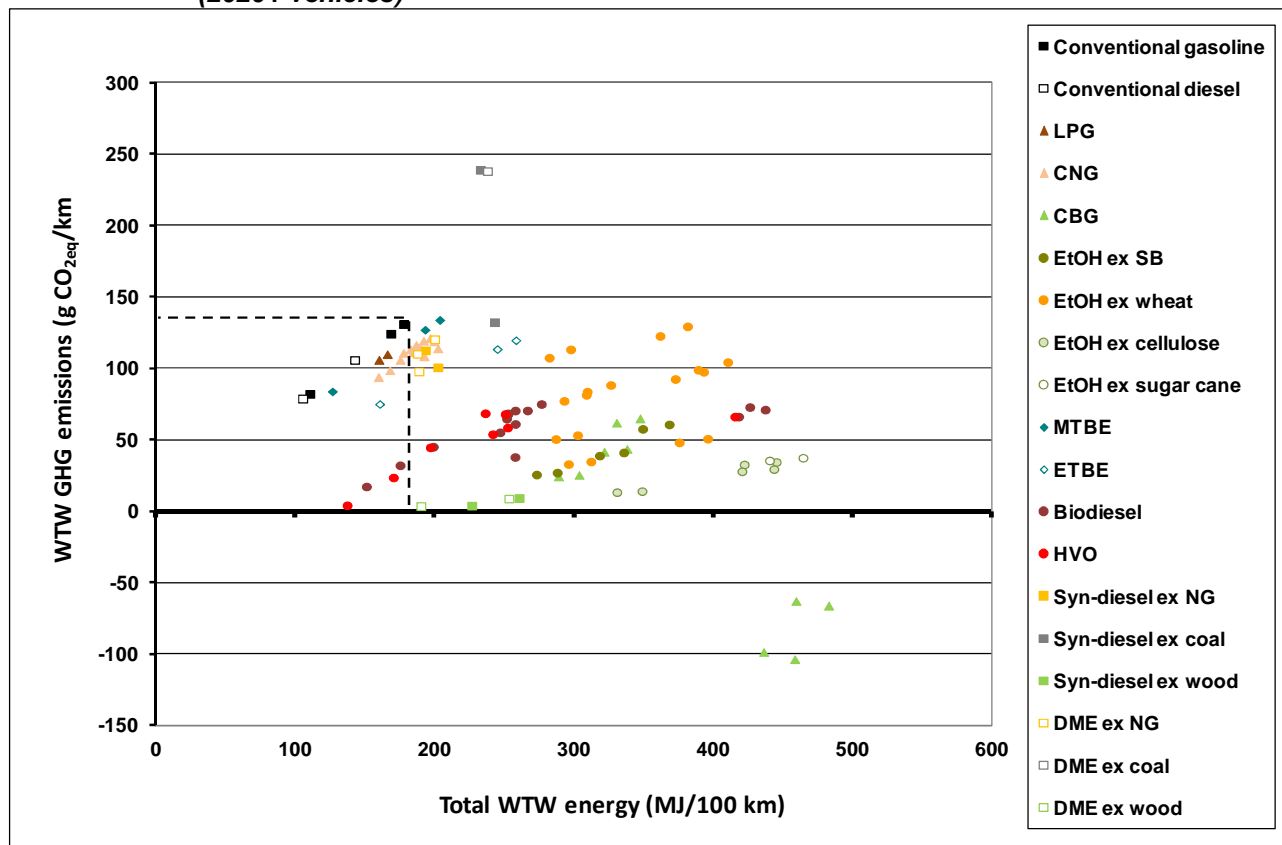

Notes Figures plotted for 2020+ only, except for gasoline/diesel where 2010 is also included
 Dotted lines mark 2020+ PISI gasoline vehicle
 Biofuels plotted as neat products
 Pathways from renewable electricity excluded - discussed in Section 6.3

Virtually all primary energy resources are in practice available in limited quantities. For fossil fuels the limit is physical, expressed in barrels or m³ actually present in the ground and recoverable. For biomass the limit is total available land use. The planet is unlikely to run out of sun or out of wind in the foreseeable future but our capacity to harness these energies is very much limited by our ability to build enough converters at an

economic cost and find acceptable sites to install them. In other words, access to primary energy is limited and it is therefore important to consider how GHG reductions could be achieved at minimum energy expenditure.

In the following sections we look at the various ways of using primary resources to produce road fuels and compare these with electricity generation as a reference point. An exhaustive analysis would require consideration not only of road transport and electricity but of the whole energy sector.

6.1 Natural gas

Within the limited scope considered in this study for using natural gas as a source of transportation, availability of natural gas is not a real issue. There are, however, large differences in the amount of GHG that can be avoided with one MJ of natural gas.

To illustrate this point we have considered 5 possible substitution options (**Figure 6.1**):

- NG is commonly used to produce electricity and could replace coal, often considered as the marginal fuel for electricity production. Electricity from coal is GHG-intensive. Substitution by NG provides large GHG savings.
- CNG as transportation fuel only provides small savings because its global GHG balance is close to that of the gasoline and diesel fuels it would replace.
- The opposite holds for Syndiesel fuel which is slightly more GHG-intensive than conventional diesel fuel.
- Direct hydrogen production has the potential to save large amounts of GHG as long as the hydrogen is used in a fuel cell thereby reaping the energy efficiency benefit. The savings are, however, still much less than in the coal substitution case. In this version of the study the fuel consumption of fuel cell vehicles in 2020+ is projected to be less than half that of ICE vehicles and this factor is responsible for the larger savings in GHG emissions than were reported in version 3.
- However, using gas to produce electricity and then hydrogen via electrolysis is an inefficient process because of the energy consumed both in power generation and electrolysis.

Figure 6.1 CO₂ avoidance from alternative uses of natural gas

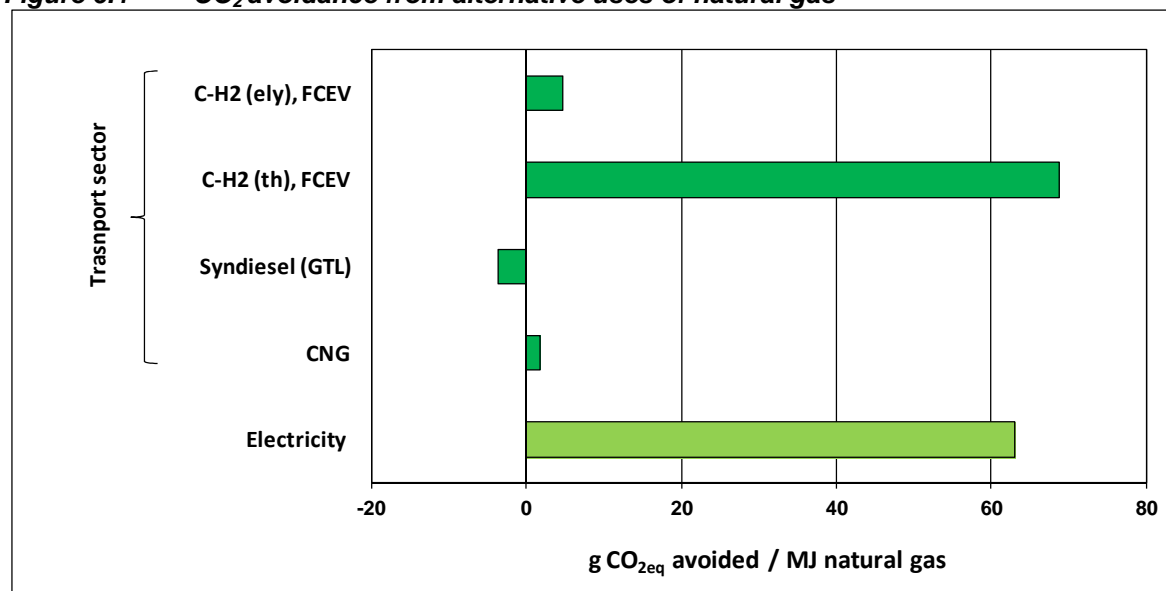

Key to options

Option				Compared to		
Tag	WTT pathway		2020+ Vehicle	WTT pathway		2020+ Vehicle
	Description	Code		Description	Code	
Electricity	Electricity ex LNG	GREL1	NA	Electricity from coal, state-of-the-art conventional	KOEL1	NA
CNG	CNG from LNG	GRCG1	DISI	Gasoline/diesel, 55/45 split	COG1 COD1	DISI DICI
Syndiesel (GTL)	Syndiesel from remote natural gas	GRSD1	DISI			
C-H2 (th), FCEV	Compressed hydrogen from LNG, central reforming	GRCH1	FCEV			
C-H2 (ely), FCEV	Compressed hydrogen from piped natural gas (4000 km), via electricity (CCGT) and on-site electrolysis	GPEL1b /CH1	FCEV			

- CNG as transportation fuel only provides small savings because its global GHG balance is close to that of the gasoline and diesel fuels it would replace.
- With the improvements expected in fuel cell vehicle efficiency at the 2020+ horizon, production of hydrogen from NG by reforming and use in a FC vehicle has the potential to save as much GHG emission as substituting coal by NG in power generation.

6.2 Biomass

Except for straw, which in suitable areas can be taken from food crops, and organic waste, land is the common biomass resource. It can be used in many different ways some of which have been described in this study, but the availability of land for growing crops is essentially limited, particularly for energy crops that have to compete with food crops.

In the following figure we consider a hypothetical hectare of land and compare its “CO₂ avoidance potential” when used with different crops. The range shown for each option corresponds to the different pathways available, based on a selection of the pathways presented in this study.

Figure 6.2 CO₂ avoidance from alternative uses of land

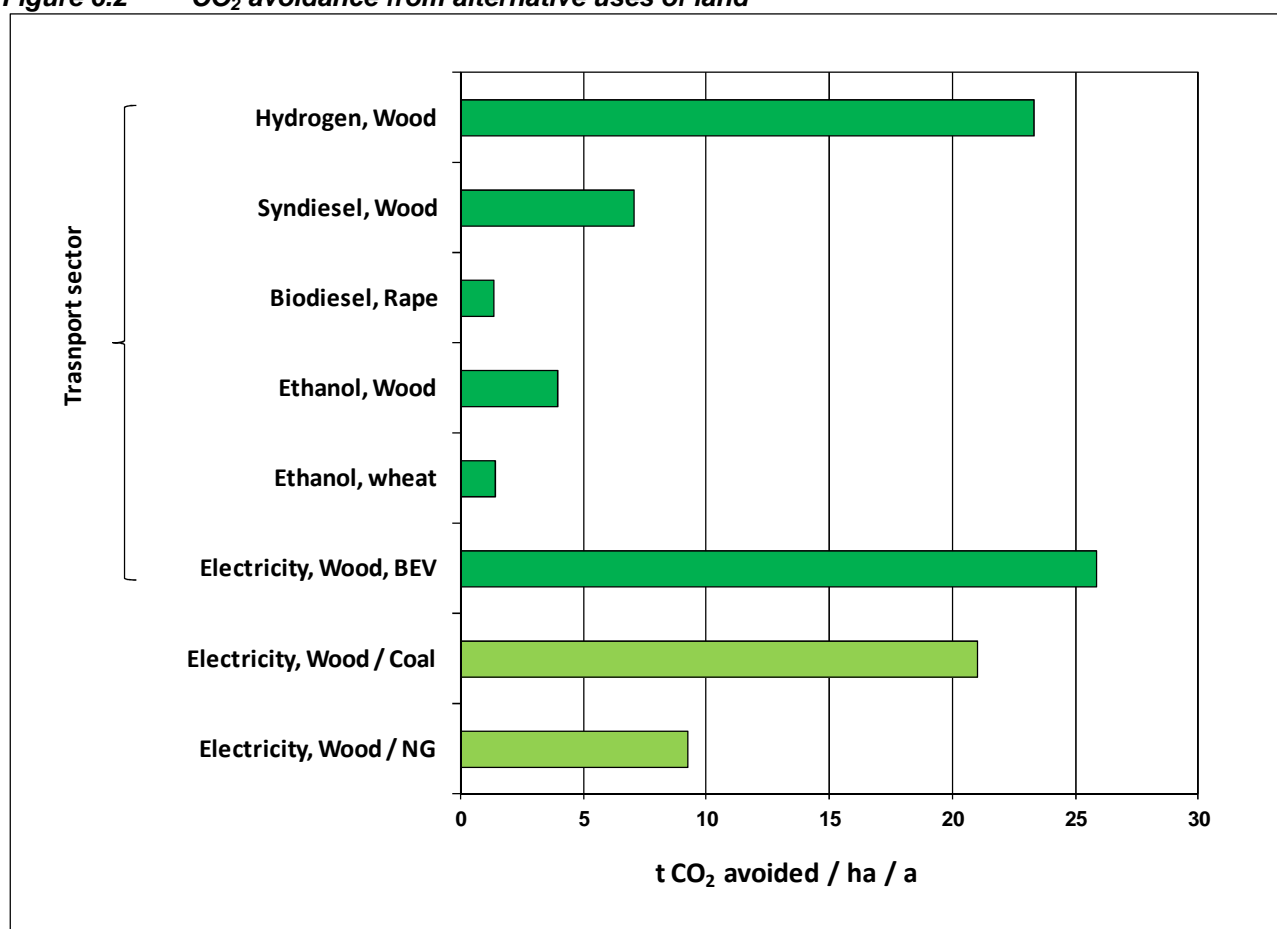

Key to options

Tag	Option			Compared to		
	WTT pathway Description	Code	2020+ Vehicle	WTT pathway Description	Code	2020+ Vehicle
Electricity, Wood / NG	Farmed wood, large IGCC	WFEL1	NA	Electricity from piped natural gas (4000 km), CCGT	GPEL1b	NA
Electricity, Wood / Coal	Farmed wood, large IGCC	WFEL1	NA	Electricity from coal, state-of-the-art conventional	KOEL1	NA
Electricity, Wood, BEV	Farmed wood, large IGCC	WFEL1	BEV	Gasoline/diesel, 55/45 split	COG1 COD1	DISI DICI
Ethanol, wheat	Ethanol from wheat, NG CCGT, DDGS to animal feed	WTET2a	DISI	Gasoline	COG1	DISI
Ethanol, Wood	Ethanol from farmed wood	WFET1				
Biodiesel, Rape	Compressed hydrogen from LNG, central reforming	ROFA3	DICI	Diesel	COD1	DICI
Syndiesel, Wood	Compressed hydrogen from LNG, central reforming	WFSD1				
Hydrogen, Wood	Compressed hydrogen from farmed wood, central gasification + reforming	WFCH2	FCEV	Gasoline/diesel, 55/45 split	COG1 COD1	DISI DICI

Electricity production is energy intensive and substitution by biomass results in large CO₂ savings, particularly when coal is being substituted. The technology used for biomass conversion can make a lot of difference, the IGCC concept (top end of the range) being far superior to a conventional boiler and steam turbine system (but also a lot more expensive). Note that wood is used here as a proxy for all high yield energy plants. Substitution of biomass for coal in electricity generation provides one of the largest CO₂ savings.

Direct hydrogen production from wood is also attractive because of the reasonable efficiency of the conversion plants, particularly large ones and its performance is enhanced by the improved efficiency foreseen for fuel cell vehicles in 2020+. It can be better than using biomass to produce electricity but only as long as the final converter is an efficient fuel cell. Even in the latter case, electrolysis is worse than the natural gas case.

Ethanol and FAME are much less attractive partly because of yields but also because they do not allow a gain in efficiency on the vehicle side. Synthetic diesel fuel and DME fare better and are in the same range as natural gas electricity substitution. Their performance is slightly better where advantage can be taken of the black-liquor route.

This analysis is of course a little simplistic. Each hectare of land has its specific characteristics that make it most suitable for a certain kind of crop or crops (in rotation). Rape is for instance an attractive break crop on a land dedicated to cereals. One could obviously not grow wood for a year between two cereal cycles. Also yields can vary a great deal between areas and one should refrain from using the above figures to estimate the CO₂ that could be saved with a certain area of land.

The point is that there are significant overall differences between the options and one must look both at relative and absolute figures.

- At the 2020+ horizon, using farmed wood to produce hydrogen by reforming saves as much GHG emission per hectare of land as using the wood to produce electricity in place of coal and saves more GHG emissions per hectare than producing conventional or advanced biofuels.

6.3 Wind

The amount of energy that can be harnessed from wind is a matter of endless debate. The main issue is first to find suitable sites, get the appropriate approvals and public acceptance and then to construct a suitable financial structure to make a project feasible. The rate of success in doing this, rather than the number of potential sites, will determine how much wind power is installed.

Technology is moving fast with increasingly large and more efficient turbines. The impact of wind farms on the environment is a big issue and one of the major stumbling blocks. People have generally nothing against wind farms as long as they can't see or hear them. Noise is indeed one of the problems although it is being addressed by manufacturers. In the long term, offshore installations are the most promising. They cause less environmental nuisance, can be very large and can benefit from much stronger and steadier winds.

There is no serious scenario suggesting that enough wind power could be installed to produce all of the European electricity demand. Because of its intermittent and partly unpredictable nature wind electricity can be difficult to integrate into the grid without risking major upsets. Figures of 10 to 20% have been mentioned as the maximum acceptable fraction of wind electricity in the total. Whether enough wind capacity is developed remains to be seen, but there are already situations where, at times of low electricity demand, wind electricity production can exceed the capacity of the grid to accept it. Any surplus wind electricity, either structural or occasional, could be used to produce fuels that can be stored for later use. Hydrogen has been considered in this context for several years and more recently processes to produce synthetic diesel or synthetic methane via methanol have been suggested.

The following figure illustrates the CO₂ avoidance potential of wind electricity.

Figure 6.3 CO₂ avoidance potential of wind electricity

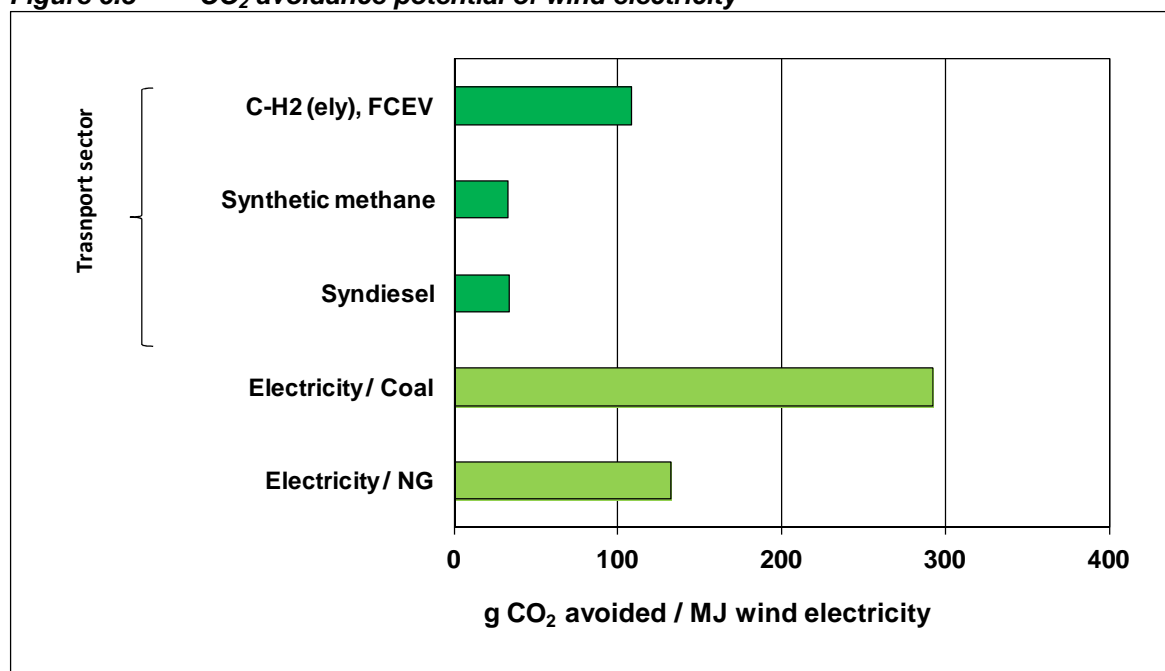

Key to options

Tag	Option			Compared to		
	WTT pathway Description	Code	2020+ Vehicle	WTT pathway Description	Code	2020+ Vehicle
Electricity / NG	Wind electricity, LV distribution through grid	GREL1	NA	Electricity from piped natural gas (4000 km), CCGT	GPEL1b	NA
Electricity / Coal	Wind electricity, LV distribution through grid	GRCG1	NA	Electricity from coal, state-of-the-art conventional	KOEL1	NA
Syndiesel	Wind electricity, HV distribution through grid, diesel synthesis via	RESD1	DICI	Diesel	COD1	DISI
Synthetic methane		RECG1	DISI	CNG	GPCG1b	DISI
C-H2 (ely), FCEV		WDEL1/CH2	FCEV	Gasoline/diesel, 55/45 split	COG1 COD1	DISI DICI

Substituting electricity from natural gas gives GHG reductions around half those from substituting coal electricity.

Using wind electricity to produce hydrogen through electrolysis introduces energy losses through the electrolyser, but this is compensated by the high efficiency of the fuel cell vehicle. In this estimate, the savings from hydrogen come close to those from substituting NG electricity.

The alternative pathways via methanol to synthetic diesel or methane are, however, much more energy intensive. The amount of input electricity to produce 1MJ of hydrogen is 1.87MJ, for synthetic methane it is 2.06MJ and for synthetic diesel it is 2.60MJ. In addition, these fuels cannot take advantage of the efficient fuel cell vehicle, so their CO₂ savings are much lower.

Even if the WTW GHG emissions for renewable fuels are low per MJ of finished fuel, those pathways that are less energy intensive in fuel production will produce the greatest GHG emission savings overall.

- When sourcing wind electricity for transport fuels, hydrogen production and use in FCEV is more efficient than the application of synthetic diesel or methane in ICE-based vehicles.
- Using wind electricity to produce hydrogen and use it in FCEV saves slightly less GHG emissions than substituting NG CCGT electricity.
- Using wind electricity to substitute coal electricity is the most efficient option for GHG savings.

Acronyms and abbreviations used in the WTW study

AVL CRUISE	A vehicle simulation model developed by AVL List GmbH
BEV	Battery Electric Vehicle
BTL	Biomass-To-Liquids: denotes processes to convert biomass to synthetic liquid fuels, primarily diesel fuel
CAP	The EU's Common Agricultural Policy
CBG	Compressed Bio-Natural Gas
CCGT	Combined Cycle Gas Turbine
CCS	CO ₂ capture and storage
CD / CS	Charge Depletion / Charge Sustaining
C-H ₂	Compressed hydrogen
CHP	Combined Heat and Power
CI	Compression Ignition
CNG	Compressed Natural Gas
CO	Carbon monoxide
CO ₂	Carbon dioxide: the principal greenhouse gas
CONCAWE	The oil companies' European association for environment, health and safety in refining and distribution
DC/DC	Power controller: direct current
DDGS	Distiller's Dried Grain with Solubles: the residue left after production of ethanol from wheat grain
DG-AGRI	The EU Commission's General Directorate for Agriculture
DICI	An ICE using the Direct Injection Compression Ignition technology
DME	Di-Methyl-Ether
DPF	Diesel Particulate Filter
DISI	An ICE using the Direct Injection Spark Ignition technology

ETBE	Ethyl-Tertiary-Butyl Ether
EUCAR	European Council for Automotive Research and Development
EU-mix	The average composition of a certain resource or fuel in Europe. Applied to natural gas, coal and electricity
FAEE	Fatty Acid Ethyl Ester: Scientific name for bio-diesel made from vegetable oil and ethanol
FAME	Fatty Acid Methyl Ester: Scientific name for bio-diesel made from vegetable oil and methanol
FAPRI	Food and Agriculture Policy Research Institute (USA)
FC	Fuel Cell
FSU	Former Soviet Union
FT	Fischer-Tropsch: the process named after its original inventors that converts syngas to hydrocarbon chains
GDP	Gross Domestic Product
GHG	Greenhouse gas
GNOC	Global crop and site specific Nitrous Oxide emission Calculator
GTL	Gas-To-Liquids: denotes processes to convert natural gas to liquid fuels
HC	Hydrocarbons (as a regulated pollutant)
HRSG	Heat Recovery Steam Generator
HVO	Hydrotreated Vegetable Oil
ICE	Internal Combustion Engine
IEA	International Energy Agency
IES	Institute for Environment and Sustainability
IGCC	Integrated Gasification and Combined Cycle
IPCC	Intergovernmental Panel for Climate Change
JRC	Joint Research Centre of the EU Commission
LBST	Ludwig-Bölkow Systemtechnik GmbH
LCA	Life Cycle Assessment

L-H ₂	Liquid hydrogen
LHV	Lower Heating Value ("Lower" indicates that the heat of condensation of water is not included)
LNG	Liquefied Natural Gas
LPG	Liquefied Petroleum Gases
MDEA	Methyl Di-Ethanol Amine
ME	The Middle East
MTBE	Methyl-Tertiary-Butyl Ether
MPa	Mega Pascal, unit of pressure (1 MPa = 10 bar). Unless otherwise stated pressure figures are expressed as "gauge" i.e. over and above atmospheric pressure
Mtoe	Million tonnes oil equivalent. The "oil equivalent" is a notional fuel with a LHV of 42 GJ/t
N ₂ O	Nitrous oxide: a very potent greenhouse gas
NEDC	New European Drive Cycle
NG	Natural Gas
NO _x	A mixture of various nitrogen oxides as emitted by combustion sources
OCF	Oil Cost Factor
OGP	International Oil & Gas Producers Association
PEM fuel cell	Proton Exchange Membrane fuel cell
PHEV	Plug-in Hybrid Electric Vehicle
PISI	An ICE using Port Injection Spark Ignition technology
PSA	Pressure Swing Absorption unit
REEV	Range Extended Electric Vehicle
RME	Rapeseed Methyl Ester: biodiesel derived from rapeseed oil (colza)
SI	Spark Ignition
SMDS	The Shell Middle Distillate Synthesis process
SME	Sunflower Methyl Ester: biodiesel derived from sunflower oil

SOC	State Of Charge (of a battery)
SRF	Short Rotation Forestry
SSCF	Simultaneous Saccharification and Co-Fermentation: a process for converting cellulosic material to ethanol
SUV	Sport-Utility Vehicle
Syngas	A mixture of CO and hydrogen produced by gasification or steam reforming of various feedstocks and used for the manufacture of synthetic fuels and hydrogen
TES	Transport Energy Strategy. A German consortium that worked on alternative fuels, in particular on hydrogen
TTW	Tank-To-Wheels: description of delivering vehicle motion by fuel use
ULCC	Ultra Large Crude Carrier
VLCC	Very Large Crude Carrier
WTT	Well-To-Tank: the cascade of steps required to produce and distribute a fuel (starting from the primary energy resource), including vehicle refuelling
WTW	Well-To-Wheels: the integration of all steps required to produce and distribute a fuel (starting from the primary energy resource) and use it in a vehicle
ZEV	Zero Emission Vehicle

Europe Direct is a service to help you find answers to your questions about the European Union

Freephone number (*): 00 800 6 7 8 9 10 11

(*) Certain mobile telephone operators do not allow access to 00 800 numbers or these calls may be billed.

A great deal of additional information on the European Union is available on the Internet.

It can be accessed through the Europa server <http://europa.eu/>.

How to obtain EU publications

Our priced publications are available from EU Bookshop (<http://bookshop.europa.eu/>), where you can place an order with the sales agent of your choice.

The Publications Office has a worldwide network of sales agents.

You can obtain their contact details by sending a fax to (352) 29 29-42758.

European Commission

EUR 26236 EN – Joint Research Centre – Institute for Energy and Transport

Title: WELL-TO-WHEELS Report Version 4.a. JEC WELL-TO-WHEELS ANALYSIS

Author(s): Robert EDWARDS (JRC), Heinz HASS (EUCAR), Jean-François LARIVÉ (CONCAWE), Laura LONZA (JRC), Heiko MAAS (EUCAR), David Rickeard (CONCAWE)

Luxembourg: Publications Office of the European Union

2014 – 96 pp. – 21.0 x 29.7 cm

EUR – Scientific and Technical Research series –ISSN 1831-9424 (online)

ISBN 978-92-79-33887-8 (PDF)

doi: 10.2790/95533

Abstract

The JEC research partners [Joint Research Centre of the European Commission, EUCAR and CONCAWE] have updated their joint evaluation of the well-to-wheels energy use and greenhouse gas emissions for a wide range of potential future fuel and powertrain options.

This document reports on the fourth release of this study replacing Version 3c published in July 2011.

The original version was published in December 2003.

JRC Mission

As the Commission's in-house science service, the Joint Research Centre's mission is to provide EU policies with independent, evidence-based scientific and technical support throughout the whole policy cycle.

Working in close cooperation with policy Directorates-General, the JRC addresses key societal challenges while stimulating innovation through developing new methods, tools and standards, and sharing its know-how with the Member States, the scientific community and international partners.

*Serving society
Stimulating innovation
Supporting legislation*

