



Title	Wireless power transfer and fault diagnosis of high-voltage power line via robotic bird
Author(s)	Liu, C; Chau, KT; Zhang, Z; Qiu, C; Li, WL; Ching, TW
Citation	Journal of Applied Physics, 2015, v. 117 n. 17, article no. 17D521, p. 17D521:1-4
Issued Date	2015
URL	http://hdl.handle.net/10722/216939
Rights	Journal of Applied Physics. Copyright © American Institute of Physics.

Wireless power transfer and fault diagnosis of high-voltage power line via robotic bird

Chunhua Liu, K. T. Chau, Zhen Zhang, Chun Qiu, Wenlong Li, and T. W. Ching

Citation: *Journal of Applied Physics* **117**, 17D521 (2015); doi: 10.1063/1.4919117

View online: <http://dx.doi.org/10.1063/1.4919117>

View Table of Contents: <http://scitation.aip.org/content/aip/journal/jap/117/17?ver=pdfcov>

Published by the [AIP Publishing](#)

Articles you may be interested in

[Birds on power lines](#)

Am. J. Phys. **82**, 691 (2014); 10.1119/1.4874259

[Design and testing of piezoelectric energy harvester for powering wireless sensors of electric line monitoring system](#)

J. Appl. Phys. **111**, 07E510 (2012); 10.1063/1.3677771

[High-Voltage Characterization for the Prototype Induction Cells](#)

AIP Conf. Proc. **650**, 45 (2002); 10.1063/1.1530798

[Study of a fast, high-impedance, high-voltage pulse divider](#)

Rev. Sci. Instrum. **72**, 4266 (2001); 10.1063/1.1408937

[High-voltage subnanosecond pulse transformer composed of parallel-strip transmission lines](#)

Rev. Sci. Instrum. **70**, 232 (1999); 10.1063/1.1149570

The logo for AIP APL Photonics is displayed in white text on a red background. The letters 'AIP' are large and bold, followed by a vertical bar and the words 'APL Photonics' in a smaller font.

APL Photonics is pleased to announce
Benjamin Eggleton as its Editor-in-Chief



Wireless power transfer and fault diagnosis of high-voltage power line via robotic bird

Chunhua Liu,^{1,a)} K. T. Chau,¹ Zhen Zhang,¹ Chun Qiu,¹ Wenlong Li,¹ and T. W. Ching²

¹Department of Electrical and Electronic Engineering, University of Hong Kong, Hong Kong, China

²Faculty of Science and Technology, University of Macau, Macau, China

(Presented 6 November 2014; received 22 September 2014; accepted 4 January 2015; published online 24 April 2015)

This paper presents a new idea of wireless power transfer (WPT) and fault diagnosis (FD) of high-voltage power line via robotic bird. The key is to present the conceptual robotic bird with WPT coupling coil for detecting and capturing the energy from the high-voltage power line. If the power line works in normal condition, the robotic bird is able to stand on the power line and extract energy from it. If fault occurs on the power line, the corresponding magnetic field distribution will become different from that in the normal situation. By analyzing the magnetic field distribution of the power line, the WPT to the robotic bird and the FD by the robotic bird are performed and verified. © 2015 AIP Publishing LLC. [<http://dx.doi.org/10.1063/1.4919117>]

I. INTRODUCTION

High-voltage power lines are normally located far away from human living areas, such as running over hills, mountains, and woods. This leads to the difficulty in positioning faults of high-voltage power lines. Although there are various techniques for locating the fault position of power lines, they usually involve high cost for installation of the auxiliary apparatus or for realization of the complicated algorithm.^{1,2}

Wireless power transfer (WPT) technologies have been actively developed in recent years, which can effectively transmit the power in a cordless way.^{3,4} This WPT is performed with the conditions of providing magnetic field, power transmitter, and coupling receptor. And the high-voltage power line inherently fulfils the first two conditions. It means that if an equipment has the coupling receptor, this equipment can harness the energy from the power line.⁵

The purpose of this paper is to propose the WPT and fault diagnosis (FD) of high-voltage power lines via robotic bird. First, the conceptual robotic bird is designed with the WPT coupling coil, which is able to stand on the power line, and then extract energy from the power line. So, the robotic bird and the power line utilize the mechanism of inductive power transfer (IPT). The energy captured from the power line using WPT is stored in a battery or ultracapacitor. Hence, the robotic bird is able to fly over the power lines. Moreover, the robotic bird can stand on or even fly along the power lines to perform the FD based on the corresponding magnetic field distribution. If the power line has a fault, the magnetic field distribution will become different from the normal situation. Thus, the robotic bird is able to make a judgment of the operating condition of power lines. And the faulty information will be sent to the operator of the local grid. This work will be analyzed by using by JMAG. Both the WPT to the robotic bird and the FD by the robotic bird

will be assessed by analyzing the magnetic field distribution of the power line.

II. WPT-FD SYSTEM WITH ROBOTIC BIRD

Fig. 1(a) shows the proposed WPT-FD system with robotic bird for power lines, which consists of one or several robotic birds and high-voltage power lines only. The high-voltage power line provides an ideal magnetic field condition and power transfer capability. The robotic bird is equipped with the driving motor, energy storage (battery or ultracapacitor), global position system (GPS), control unit, FD measuring device, and WPT coupling receptor. Thus, the operation

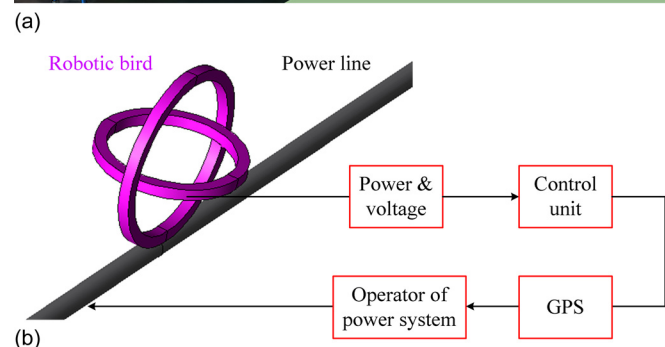
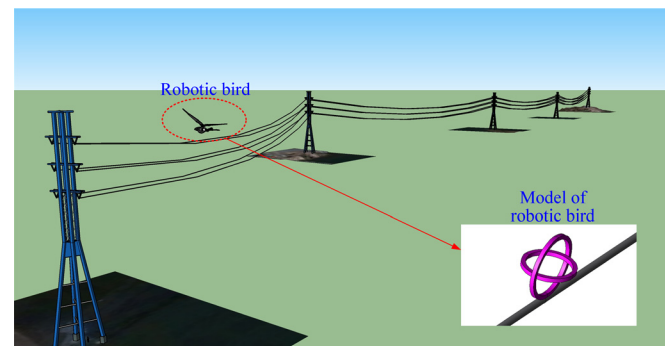

FIG. 1. Schematic diagram of WPT-FD system for high-voltage power line via robotic bird. (a) System configuration. (b) WPT-FD principle.

^{a)}Author to whom correspondence should be addressed. E-mail: chualiu@eee.hku.hk.

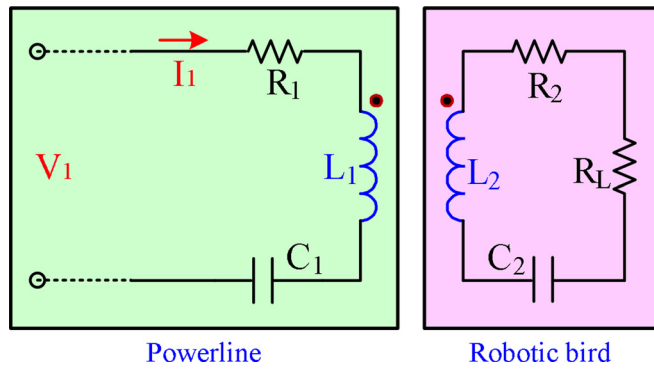

FIG. 2. Basic circuit topology of WPT-FD system.

principle of this WPT-FD system is shown in Fig. 1(b). Namely, when the robotic bird stands on the power line, its coupling receptor is able to capture the energy from the power line based on the IPT mechanism. When the power line is at normal situation, the robotic bird captures the power line energy and stores it in the battery or ultracapacitor. If the power line has a fault, the magnetic field distribution will become different from that in the normal situation. Thus, the measuring device carried by the robotic bird is able to make a judgment whether there is a fault in the power lines. And then

it can send the information to operator of the local grid, including the fault located by the GPS and the measured power parameters. Theoretically, the robotic bird is able to fly along the power lines for FD. In practice, in order to improve the power capture and diagnostic accuracy, the robotic bird prefers to stand on the power line to conduct the WPT and perform the FD. Meanwhile, when the robotic bird stands on the line, its two paws serve to grasp the line and its two outstretched wings are for keeping balance.

Fig. 2 shows the basic circuit topology of the proposed WPT-FD system with robotic bird, which mainly comprises of two parts, namely, the power line as the energy transmitter and the robotic bird as the energy receptor. They include the energy source of V_1 , load of R_L , two resistors of R_1 and R_2 , capacitors of C_1 and C_2 , as well as inductors of L_1 and L_2 . Normally, based on previous research,^{3,4} the transmitting power is mainly affected by the power level, the operating frequency, the resonant capacitor and the transmission distance. Since the operating frequency of power lines is fixed at 50 Hz or 60 Hz and the robotic bird normally stands on the power line during charging, the fixed frequency leads to a fixed resonant capacitor and the transmission distance is nearly constant. So, the transmitting power of the proposed system virtually depends on the power level of the power

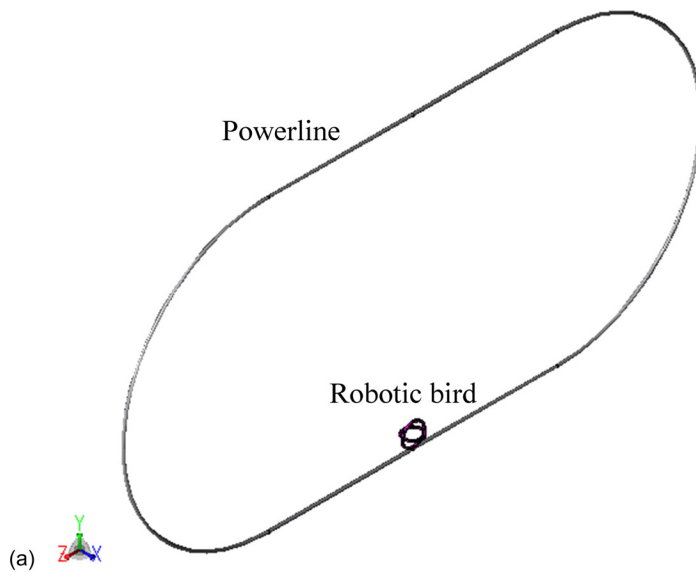
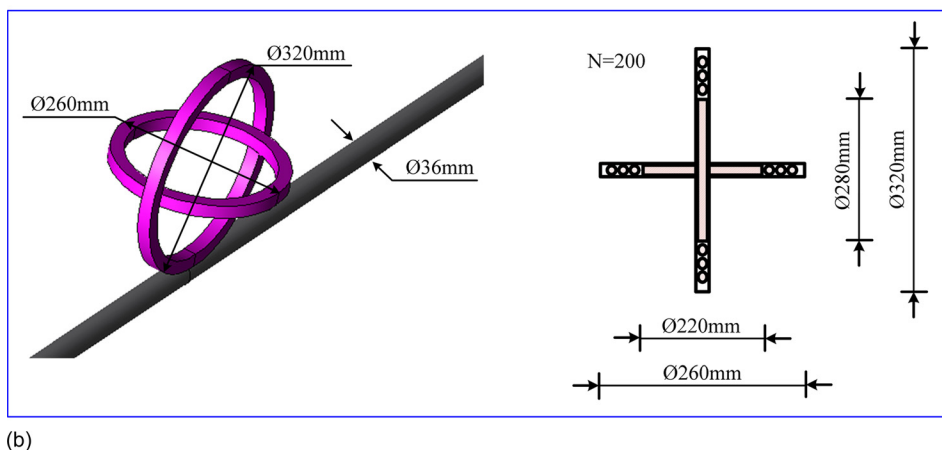

FIG. 3. Prototype of power line and robotic bird. (a) Model. (b) Geometry.



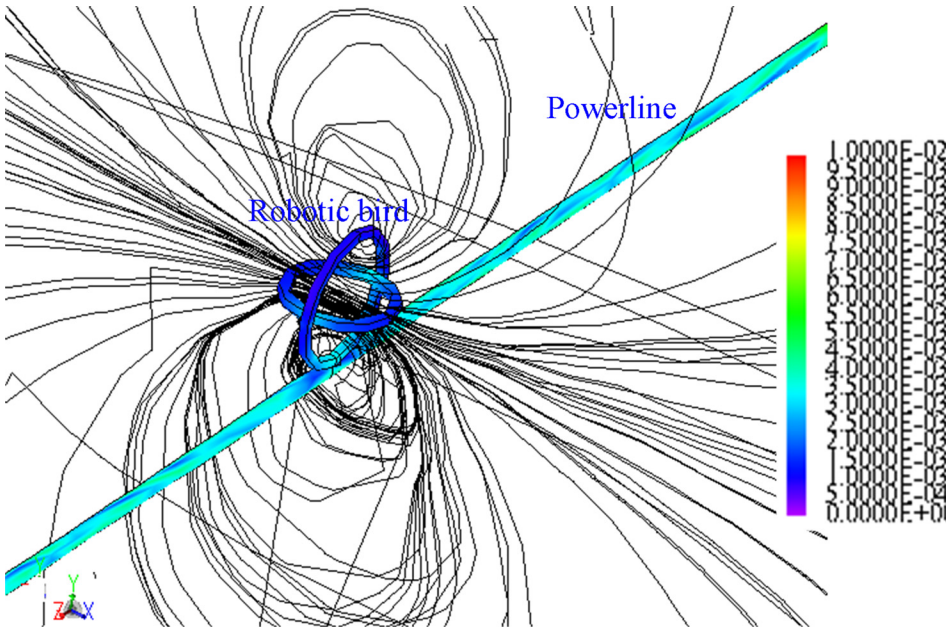

FIG. 4. Magnetic flux distribution of high-voltage power line and robotic bird under normal condition.

line only. The corresponding operation principle can be illustrated by the following equations:^{3,4}

$$\begin{bmatrix} V_S \\ V_L \end{bmatrix} = \begin{bmatrix} R_1 + j\omega L_1 + 1/j\omega C_1 & j\omega M \\ j\omega M & R_2 + j\omega L_2 + 1/j\omega C_2 \end{bmatrix} \cdot \begin{bmatrix} I_S \\ I_L \end{bmatrix}, \quad (1)$$

where V_S denotes the source voltage, V_L is the load voltage, I_L is the load current, M is the mutual inductance, and ω denotes the operating frequency.

At resonance, it yields $j\omega L_x + 1/j\omega C_x = 0$. So, Eq. (1) can be simplified as

$$\begin{bmatrix} V_S \\ V_L \end{bmatrix} = \begin{bmatrix} R_1 & j\omega M \\ j\omega M & R_2 \end{bmatrix} \cdot \begin{bmatrix} I_S \\ I_L \end{bmatrix}. \quad (2)$$

Thus, the corresponding output power P_L can be obtained as

$$P_L = \frac{V_S^2 \omega^2 M^2 R_L}{(R_1(R_2 + R_L) + \omega^2 M^2)^2}. \quad (3)$$

III. VERIFICATION

Fig. 3 shows the model prototype of robotic bird and power line for testing. The model is based on a loop to represent the power line and two crossing coils to represent the energy receptor of the robotic bird. The power line adopts the high voltage of 110 kV for testing, which has the line diameter of 36.0 mm and the line-to-line distance of 4000.0 mm, as well as the resistance, capacitance, and inductance of 0.0005 Ω , 0.4283 F, and 16.43 μ Hz, respectively. The receptor of the robotic bird has the outside diameter of 320 mm and inside diameter of 220 mm, as well as the resistance, capacitance, and inductance of 0.1 Ω , 0.4646 mF, and 15.145 mHz, respectively. By using finite-element electromagnetic analysis,⁶ the proposed WPT-FD system with robotic bird is analyzed. As well known, the normal operation current of the

110 kV power line is from 600 A to 2000 A. Thus, the current value of 500 A is defined as the threshold for normal condition, below 100 A for faulty condition, and between 100 A and 500 A for warning condition.

First, the magnetic field distribution under the normal conditions of 1000 A and 60 Hz is shown in Fig. 4. It can be observed that under the normal condition the magnetic flux lines generated by the power line are quite smooth. Then, since the robotic bird attracts the energy from the power line, the flux lines go through one of the receiving coils and form the corresponding circles. Hence, it leads to perform WPT from the power line to the robotic bird. The magnetic flux density varies from 3.2758×10^{-5} T to 9.9009×10^{-3} T. However, if the power line has a fault with the conducting current dropping to 100 A, the magnetic flux density will subsequently drop to the value ranging from 3.2758×10^{-6} T to 9.9009×10^{-4} T. Thus, the corresponding charging power and induced voltage for the robotic bird will be very different. Hence, it offers a good chance for FD of power lines based on the conductive current of power lines.

Second, Figs. 5 and 6 show the charging power and induced voltage for the robotic bird when it stands on the power line. Under the normal situation, the robotic bird is able to harness the power from 4.8 W to 76.5 W and induce

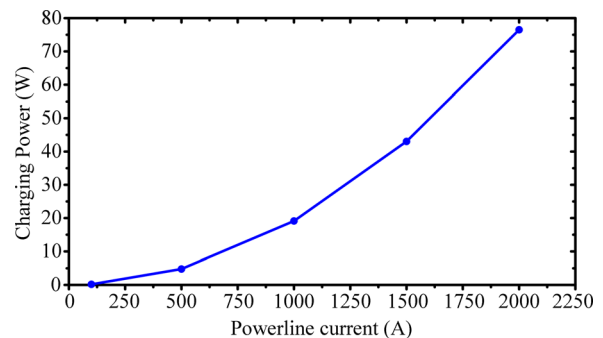

FIG. 5. Charging power for robotic bird via power line under different line currents.

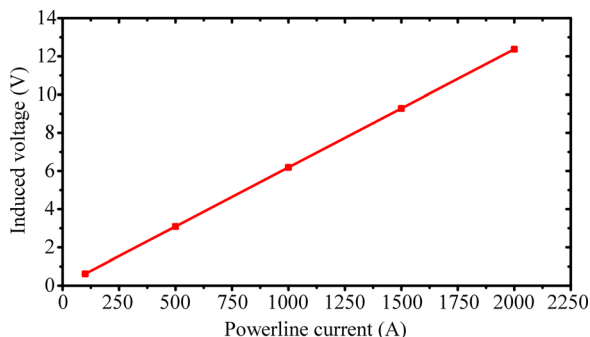

FIG. 6. Induced voltage of robotic bird via power line under different line currents.

TABLE I. Performance summary of proposed WPT-FD System via robotic bird.

Power line current (A)	Induced voltage (V) for robotic bird	Charging power (W) for robotic bird	Status of power line
...	Fault
100	0.62	0.2	Fault
...	Fault
500	3.09	4.8	Warning (threshold)
...	Normal
1000	6.19	19.2	Normal
1500	9.28	43.1	Normal
2000	12.37	76.5	Normal

the voltage from 3.09 V to 12.37 V. Under the warning condition, the receptor of the robotic bird can only harness the power from 0.2 W to 4.8 W and induce the voltage from 0.62 V to 3.09 V. But, under the faulty condition, the robotic bird nearly cannot extract the power (below 0.2 W) or induce the voltage (below 0.62 V). Therefore, based on the charging power and induced voltage, the proposed WPT-FD system can effectively make a judgment for the operation status of high-voltage power lines.

Table I summarizes the performances of the proposed WPT-FD system with the robotic bird for high-voltage power lines. It illustrates that the proposed system is able to effectively detect the operation status of high-voltage power lines. Also, it indicates that when the 110-kV power line works at normal condition of 1000 A, the robotic bird can extract the power of 19.2 W for its battery or ultracapacitor charging. Hence, the robotic bird can perform lifelong operation without “off-line” charging and fly along or between the power lines.

IV. CONCLUSION

This paper presents a new idea for the FD of high-voltage power lines by using a conceptual robotic bird. The idea is thoroughly discussed and analyzed based on the proposed model. The results verify that the conceptual robotic bird is able to harness energy from the high-voltage power line with WPT, and detect its operation status with FD. Although the idea is verified by the 110-kV power line, it can readily be extended to other types of power lines.

ACKNOWLEDGMENTS

This work was supported and funded by a research grant from HKU Small Project Funding (Project Code: SPF 201409176208) from University of Hong Kong in Hong Kong Special Administrative Region, China.

¹A. N. Milioudis, G. T. Andreou, and D. P. Labridis, *IEEE Trans. Smart Grid* **3**(4), 1631 (2012).

²A. de Souza Gomes, M. A. Costa, T. G. A. de Faria, and W. M. Caminhas, *Trans. Power Delivery* **28**(3), 1402 (2013).

³G. A. Covic and J. T. Boys, *Proc. IEEE* **101**(6), 1276 (2013).

⁴C. Liu, K. T. Chau, C. Qiu, and F. Lin, *J. Appl. Phys.* **115**, 17E702 (2014).

⁵J. Moore and R. Tedrake, in *IEEE/RSJ International Conference on Intelligent Robots and Systems* (IEEE, 2011), p. 2700.

⁶C. Liu, K. T. Chau, and J. Zhong, *IEEE Trans. Ind. Electron.* **57**(12), 4055 (2010).