



Title	A critical review of recent progress in mid-range wireless power transfer
Author(s)	Hui, SYR; Zhong, W; Lee, CK
Citation	IEEE Transactions on Power Electronics, 2014, v. 29, n. 9, p. 4500-4511
Issued Date	2014
URL	http://hdl.handle.net/10722/185840
Rights	IEEE Transactions on Power Electronics. Copyright © IEEE.

A Critical Review of Recent Progress in Mid-Range Wireless Power Transfer

S.Y.R. Hui,* *Fellow, IEEE*, W.X. Zhong and C.K. Lee, *Member, IEEE*

Department of Electrical & Electronic Engineering, The University of Hong Kong

(* Also with Imperial College London)

Abstract—Starting from Tesla’s principles of wireless power transfer a century ago, this critical review outlines recent magneto-inductive research activities on wireless power transfer with the transmission distance greater than the transmitter coil dimension. It summarizes the operating principles of a range of wireless power research into (i) the maximum power transfer and (ii) the maximum energy efficiency principles. The differences and the implications of these two approaches are explained in terms of their energy efficiency and transmission distance capabilities. The differences between the system energy efficiency and the transmission efficiency are also highlighted. The review covers the 2-coil systems, the 4-coil systems, the systems with relay resonators and the wireless domino-resonator systems. Related issues including human exposure issues and reduction of winding resistance are also addressed. The review suggests that the use of the maximum energy efficiency principle in the 2-coil systems is suitable for short-range rather than mid-range applications, the use of the maximum power transfer principle in the 4-coil systems is good for maximizing the transmission distance, but is under a restricted system energy efficiency ($< 50\%$); the use of the maximum energy efficiency principle in relay or domino systems may offer a good compromise for good system energy efficiency and transmission distance on the condition that relay resonators can be placed between the power source and the load.

Keyword: Mid-range wireless power transfer, Tesla's resonators, maximum power transfer, maximum efficiency, human exposure, electromagnetic fields

I. INTRODUCTION

Wireless power transfer based on the magnetic resonance and near-field coupling of two loop resonators was reported by Nicola Tesla a century ago [1]. As pioneered by Tesla, wireless power transfer can be radiative or non-radiative depending on the energy transfer mechanisms. Radiative power can be emitted from an antenna and propagates through a medium (such as vacuum or air) over long distance (i.e. many times larger than the dimension of the antenna) in form of electromagnetic wave. However, due to the omni-directional nature of the radiative power emission, the energy efficiency of power transmission is very low. Non-radiative wireless power transfer relies on the near-field magnetic coupling of conductive loops and can be classified as short-range and mid-range applications. In this review, mid-range applications refer to the situation that the transmission distance between the power source and the load is larger than the dimension of the coil-resonators.

It should be noted that wireless power transfer has been applied extensively in ac machines, which were also pioneered by Tesla [2]. Using a cage induction machine as an example, energy is transferred from the excited stator windings across the air gap to the rotor cage. Energy transfer via coupled windings is the basic principle used in electric machines. Therefore, wireless power systems can be mathematically described by electric circuit theory for magnetically coupled circuits.

Wireless power transfer has been an active research topic for transcutaneous energy systems for medical implants since 1960's [3-7] and induction heaters [8] since 1970's. For modern short-range applications, the inductive power transfer (IPT) systems [9-13] and the wireless charging systems for portable equipment such as mobile phones [14-19] have attracted much attention since 1990's and

2000's respectively. Wireless charging technology for portable electronic devices has reached commercialization stage through the launch of the "Qi" Standard by the Wireless Power Consortium [20], now comprising over 135 companies worldwide. For both of the IPT systems and wireless charging pads, it has been a common practice to adopt Tesla's principles of

- 1) using near-field (i.e. non-radiative) magnetic coupling (i.e. magneto-inductive effects) ;
- 2) resonance techniques for both transmitter and receiver circuits.

The main reasons for using the near-field magnetic coupling and resonance techniques together are to compensate the leakage inductance (i.e. taking advantage of the resonance of the magnetic field and electric field for physicists and the resonance of inductance and capacitance in the LC circuit for electrical engineers) in the power flow path and to ensure good wireless transmission energy efficiency. For the IPT applications of several kilowatts such as charging electric vehicle, energy efficiency higher than 90% is possible. For the low-power wireless charging of mobile phones (up to 5W), a typical system energy efficiency exceeding 70% can be achieved. For these modern short-range domestic and industrial applications, the operating frequency is usually in the range of 20 kHz to a few megahertz. Such a frequency range is chosen because the power processing circuits (which are power electronics based switched mode power converters) with this operating frequency range are commercially available and economical. This frequency range is often neglected in recent mid-range wireless power research, but is a very important factor affecting the overall system energy efficiency and costs in both short-range and mid-range wireless power transfer systems, particularly when the power level is high. For non-radiative mid-range wireless power transfer, operating frequency ranging from 10 kHz in Tesla's work [2] to almost 200 MHz [21] has been reported. Using an operating frequency in excess of 10 MHz, for example, would substantially increase the costs and switching losses of the driving circuits.

With the short-range wireless power technology reaching a mature stage for domestic and industrial applications, mid-range wireless power research has been gathering momentum in the last decade. In

this paper, Tesla's early work on mid-range wireless power research is briefly summarized and its implications on modern research are addressed. Then recent progress on mid-range wireless power applications, starting from the use of (i) 2-coil systems (ii) 4-coil system with impedance matching (iii) wireless power systems with relay resonators (iv) wireless power domino-resonator systems is described. Their operating principles can be summarized as the maximum power transfer and maximum energy efficiency principles. While these systems are still based on Tesla's wireless power transfer principles, some new advancements such as techniques to extend the transmission distance not previously described by Tesla are described. This paper is an extended version of [22]. The frequency-splitting phenomenon of wireless power systems previously observed is explained. Related technologies such as reduction of winding resistance and control techniques are also included. Critical comments on the practical issues essential to the engineering implementation are included so as to link theory and practice together.

II. TESLA'S EARLY WORK ON NON-RADIATIVE MID-RANGE WIRELESS POWER TRANSFER

Tesla was the inventor of a series of technologies that have affected human society since the 20th century [2]. His work on tuned circuits, wireless power and radio circuits shared some common themes. In a study of Tesla's contributions [23], some important quotations are cited from a 1943 technical article [24] that "Tesla is entitled to either distinct priority or independent discovery of:

1. The idea of inductive coupling between the driving and the working circuits.
2. The importance of tuning both circuits, that is, the idea of an 'oscillation transformer'.
3. The idea of a capacitance loaded open secondary circuit."

Obviously, these 3 aspects of discovery have formed the founding principles for both non-radiative and radiative wireless transfer. In particular, his discovery of using both tuned circuits as an "oscillation transformer" indicates that both of the transmitter and receiver circuits are tuned to operate in the

resonance mode. The “oscillation transformer” concept goes beyond pure magnetic induction principle, and more precisely, refers to the use of magnetic resonance between two magnetically coupled coil-resonators. The combined use of magnetic induction, tuned circuits and resonance operating frequency has been a common theme in his wireless power and radio investigations. Some of these features are later referred to as “non-radiative”, “magneto-inductive” and “magnetic resonance” in recent mid-range wireless power research.

Despite the lack of modern equipment such as an RF power amplifier or other forms of high-power power supply with tens of megahertz frequency range a century ago, Tesla’s early work on non-radiative wireless power still influences recent mid-range wireless applications. According to [2], Tesla designed his own ‘high-frequency’ ac generator and managed to test his apparatus at 10 kHz to 20 kHz. A diagram of one of Tesla’s mid-range wireless power transfer experiment is shown in Fig.1 [25]. The setup consists of a primary (transmitter) coil and a secondary (receiver) coil. While Tesla’s idea of a capacitance loaded open secondary circuit is highlighted in [23, 24], it should be noted that if a high-frequency power supply that could work up to several tens of megahertz were available in Tesla’s time, he could have taken the advantage of the intra-winding capacitance of the receiver coil for magnetic resonance.

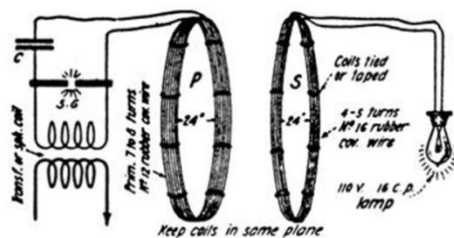

Fig.1 A diagram of one of Tesla’s wireless power experiments [25]

For efficient wireless power transfer, Tesla showed that using magnetic resonance between a pair of magnetically coupled coil-resonators could achieve optimal energy transfer. This discovery has also been the focal point in recent mid-range wireless power research. The use of the resonance concept is in

line with his other inventions such as tuned circuits for radios [26] and his low-frequency wireless power transfer via natural media (e.g. the use of the resonance frequency of the earth) [23].

III BASIC PRINCIPLES FOR MID-RANGE WIRELESS POWER TRANSFER

Recent mid-range wireless power systems can be mathematically described using the electric circuit theory. Assuming a general system with n magnetically coupled coil-resonators as shown in Fig.2, the mathematical model can be developed as:

$$\begin{bmatrix} R_1 + j(\omega L_1 - \frac{1}{\omega C_1}) & j\omega M_{12} & j\omega M_{13} & \cdots & \cdots & j\omega M_{1n} \\ j\omega M_{12} & R_2 + j(\omega L_2 - \frac{1}{\omega C_2}) & j\omega M_{23} & \cdots & \cdots & j\omega M_{2n} \\ \vdots & \vdots & \vdots & \ddots & \vdots & \vdots \\ j\omega M_{1(n-1)} & \cdots & \cdots & R_{n-1} + j(\omega L_{n-1} - \frac{1}{\omega C_{n-1}}) & \cdots & j\omega M_{(n-1)n} \\ j\omega M_{1n} & \cdots & \cdots & j\omega M_{(n-1)n} & R_n + R_L + j(\omega L_n - \frac{1}{\omega C_n}) & \cdots \end{bmatrix} \cdot \begin{bmatrix} \mathbf{I}_1 \\ \mathbf{I}_2 \\ \vdots \\ \mathbf{I}_{n-1} \\ \mathbf{I}_n \end{bmatrix} = \begin{bmatrix} V_1 \\ 0 \\ \vdots \\ 0 \\ 0 \end{bmatrix} \quad (1)$$

where:

$M_{ij} = k_{ij}\sqrt{L_i L_j}$ ($i, j = 1, 2, \dots, n; i \neq j$) is the mutual inductance between winding- i and winding- j ;

R_L is the load resistance which is connected to winding- n ;

I_i : Current in winding- i

L_i : Self-inductance of winding- i

C_i : Compensating capacitance of winding- i

R_i : Resistance in resonator - i (including the resistance of winding- i and the equivalent series resistance of the capacitor C_i)

ω : Angular frequency

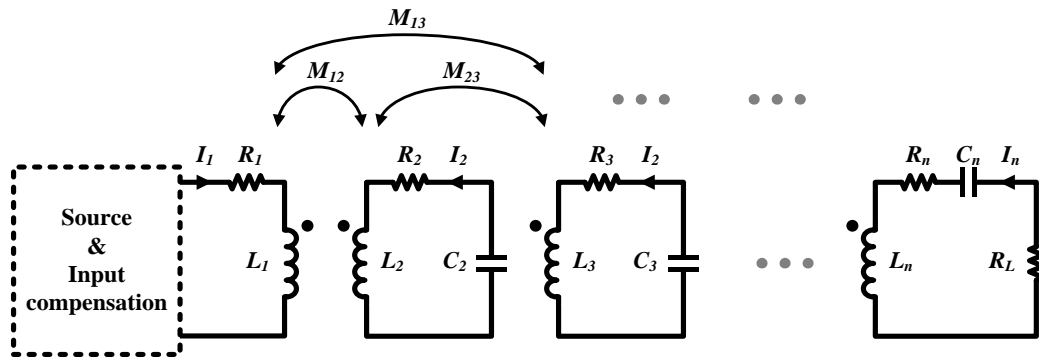

Fig.2 Schematic of a system with n resonators

A. Two Fundamental Concepts of Power Transfer

Before the recent work of mid-range wireless power research is addressed, it is important to differentiate two important basic concepts, namely (i) the maximum power transfer principle and (ii) the maximum energy efficiency principle. In the literature review, it is noted that the importance of using a power source of low impedance is often ignored in the system energy efficiency consideration. For power electronics (PE) researchers, using a power source with minimum source impedance is a basic concept for all switched mode power supply designs because the paramount priority of a power supply is high energy efficiency. However, for Radio-Frequency (RF) researchers, using the impedance matching concept (i.e. the maximum power transfer theorem) is a common practice in many RF circuit designs. To achieve high energy efficiency for wireless power transmission over the mid-range distance, it is therefore necessary to understand the advantages and disadvantages of the two power transfer principles so that practicing engineers can decide which approach they should adopt in order to suit their specific applications. The choice of the operating principles will have significant implications in terms of system energy efficiency and transmission distance.

B. Impedance Matching for Maximum Power Transfer

The impedance matching method adopted in many wireless power transfer projects is based on the maximum power transfer theorem. In general, any wireless power transfer system, regardless of it being a 2-coil or 4-coil system can be represented as an equivalent circuit as shown in Fig.3a. The maximum power transfer principle requires impedance matching between the source and the load. If the source impedance is $R_S + jX_S$ and the load impedance is $R_L + jX_L$, then maximum power can be delivered to the load if $R_S = R_L$ and $X_S = -X_L$. Recent mid-range wireless power transfer research based on the 4-coil systems adopts this approach. However, it should be noted that the maximum power transfer and maximum energy efficiency concepts are not identical. Based on the equivalent circuit shown in Fig.3a, the variations of the energy efficiency and output power are plotted in Fig.3b as functions of the ratio R_L/R_S . The maximum power theorem applies to a situation in which the source impedance is fixed. For a given R_S , the maximum power output (i.e. maximum power transfer) is achieved when R_L is equal to R_S . When R_L is larger than R_S , the larger R_L is, the higher the energy efficiency becomes. From Fig.3b, it can be seen that when maximum power transfer occurs at impedance matching, the maximum system energy efficiency under the maximum power transfer approach cannot exceed 50% as illustrated in (2).

For impedance matching (i.e. $R_S=R_L$), the system energy efficiency η_E that includes the power loss in the power source is:

$$\eta_E = \frac{i^2 R_L}{i^2 R_S + i^2 R_L} = \frac{R_L}{R_S + R_L} = 0.5 \quad (2)$$

Therefore, at least half of the power will be dissipated in the source resistance (R_S) if the maximum power theorem is adopted. Therefore, the power loss in the power source cannot be ignored in a wireless power transfer system. An example of such a low energy efficiency can be seen from [27], in which the overall system energy efficiency of a 4-coil system is only 15% while the wireless transfer efficiency (or the transmission efficiency) between the sending and receiving resonators over about 2m is about 40%. Therefore, the maximum power transfer theorem should be used in mid-range

applications in which the system energy efficiency is not of primary concern. It is suitable for relatively low power applications and unsuitable for mid- and high-power applications such as wirelessly powered public lighting systems and wireless charging of electric vehicles. Examples of suitable applications may include wireless charging of wireless sensor nodes of power in the order of tens of milliwatts.

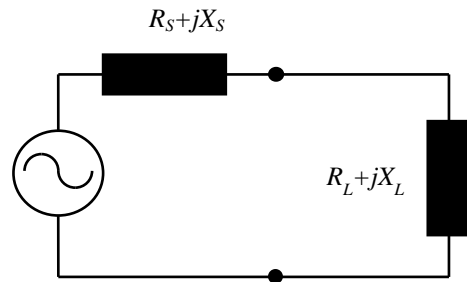

Fig.3a Equivalent circuit of an ac power source and an equivalent load.

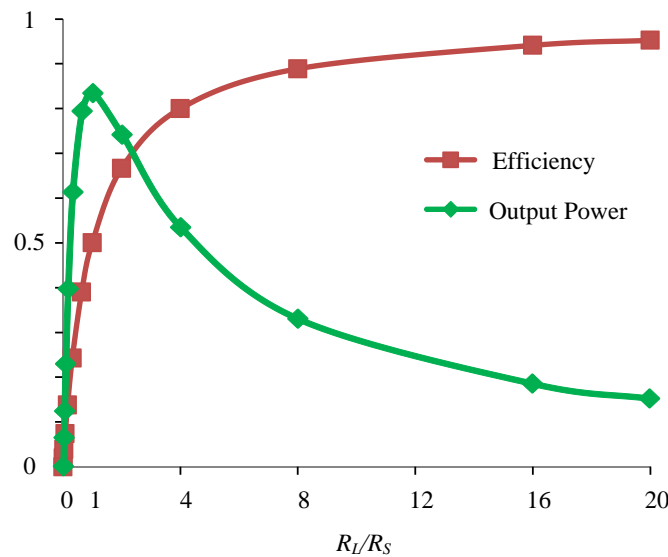

Fig.3b Variations of energy efficiency and output power as a ratio of R_L and R_S for the equivalent circuit in Fig.3a [Y-axis: Per-unit scale]

Researchers with an RF background are familiar with the use of the scattering matrix and two-port network approach as shown in Fig.4 for analyzing wireless transfer systems. It is important to differentiate the terms system energy efficiency (η_E) and transmission efficiency (η_T). The system energy efficiency refers to the ratio of the output power (P_3) and total input power (P_1) from the power source. Its calculation includes the power loss in the power source. The transmission efficiency is the ratio of the output power (P_3) and available power from the output of the power source for Port-1 (P_2), and does not include the power loss in the power source. Therefore, high transmission efficiency does not necessarily imply high system energy efficiency because the source resistance can consume a significant amount of power if the impedance matching or maximum power transfer concept is adopted.

$$\eta_E = \frac{P_3}{P_1} \quad (3)$$

$$\eta_T = \frac{P_3}{P_2} \quad (4)$$

The scattering parameters are used to analyze the forward gain of the mid-range wireless systems. For a two-port system shown in Fig.4, the relationship of the incident and reflected waves can be represented by

$$\begin{pmatrix} b_1 \\ b_2 \end{pmatrix} = \begin{pmatrix} S_{11} & S_{12} \\ S_{21} & S_{22} \end{pmatrix} \begin{pmatrix} a_1 \\ a_2 \end{pmatrix} \quad (5)$$

where a_1 and a_2 are the incident power waves on Port-1 and Port-2, respectively; b_1 and b_2 are the reflected power waves on Port-1 and Port-2, respectively. According to the definition of S-parameters, if Port-2 is terminated with a load identical to the system's source impedance then, by the maximum power transfer theorem, b_2 will be totally absorbed by the load making the reflected power a_2 equal to zero.

The forward voltage gain S_{21} (sometimes known as the transmission coefficient) is defined as:

$$S_{21} = \frac{b_2}{a_1} = \frac{V_2^-}{V_1^+} \quad (6)$$

Therefore, the S_{21} parameter, which is the ratio of the output and input voltage values, has been used as an indicator for transmission performance of mid-range wireless power systems. The maximum power transfer condition can be met by maximizing this S_{21} parameter.

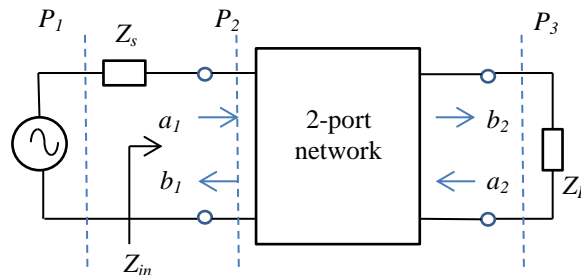

Fig.4 Schematic of a 2-port network

C. Maximum Energy Efficiency

The maximum energy efficiency principle aims at maximizing the energy efficiency in the power transfer process. Fig.3b and (2) indicate that high efficiency can be achieved by using a power source with very small source impedance. This concept is a common practice in power electronics based switched mode power supplies. If R_s is very small, the i^2R_s loss is very small and most of the power goes to the load (i^2R_L), resulting in high energy efficiency.

For a wireless power transfer system based on the use of coil-resonators, a typical equivalent circuit is shown in Fig.5. Since air-core resonators are usually used for mid-range wireless power transfer, there is no magnetic core loss. Assuming the capacitors' equivalent series resistance is negligible and non-radiative power transfer is employed, the only types of losses are the conduction loss due to the ac resistance of the coils and the power loss in the source resistance. Any loss from unwanted stray loads will decrease the energy efficiency. The control objective is therefore to maximize the system energy

efficiency function (7). In order to achieve high energy efficiency, a power source with very low source resistance R_s will be employed. The value of R_s will not be matched with the equivalent load. Litz wire or copper tube will be considered for reducing the ac winding resistance (R_1, \dots, R_N) under high frequency operation. Investigations of using superconductors are also underway to further improve the system energy efficiency. In principle, system energy efficiency higher than 50% is possible if this approach is adopted. Therefore, this approach is suitable for relatively high power applications.

$$\eta_E = \frac{i_N^2 R_L}{i_1^2 (R_s + R_1) + i_2^2 R_2 + \dots + i_N^2 (R_N + R_L)} \quad (7)$$

where η_E is system energy efficiency, i_n and R_n are the current in and the ac winding resistance of the n^{th} coil respectively; R_L is the load resistance.

The maximum energy efficiency operation relies on high magnetic coupling coefficients between the coil-resonators, which increase with the quality factor and decrease with the transmission distance. This requirement somehow restricts the transmission distance for a 2-coil system as explained in the following session. Nevertheless, transmission distance can still be extended with the use of relay resonators.

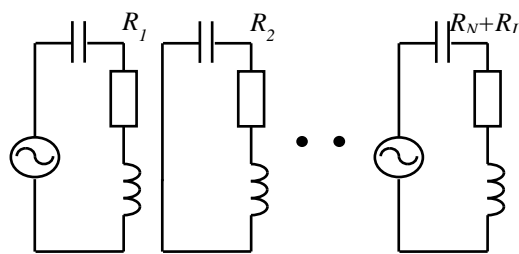

Fig.5 Equivalent circuit of a wireless power transfer based on multiple magnetically coupled resonators

IV. RECENT WORK ON MID-RANGE WIRELESS POWER TRANSFER

A. *Wireless Systems with 2 Coil-Resonators*

(i) *Energy efficiency with transmission distance*

The analysis of mutual coupling between two resonant circuits has been well established [28-30]. For mid-range applications, it has been shown in [29] that the magnetic coupling coefficients κ_{12} between two resonator coils are:

$$\kappa_{12} = \frac{1}{\left[1 + 2^{2/3} \left(d / \sqrt{r_1 r_2}\right)^2\right]^{3/2}} \quad (8)$$

if the transmission distance d is comparable with the radii of the transmitter and receiver coils r_1 and r_2 .

If $d \gg r_1$ and $d \gg r_2$.

$$\kappa_{12} \approx \frac{1}{2 \left(d / \sqrt{r_1 r_2}\right)^3} \quad (9)$$

It has also been shown that the real-power energy efficiency is proportional to the square of the magnetic coupling coefficient, implying that the efficiency drops rapidly with transmission distance (10). This seems to be the bottleneck of a 2-coil resonator system for mid-range applications and also a possible reason for the relatively lack of mid-range applications based on Tesla's original work.

$$\eta_E \propto \frac{\kappa_{12}^2}{2} \quad (10)$$

At the boundary of the short-range and mid-range transmission at which the transmitter coil dimension and the transmission distance is the same, it has been shown that high system efficiency can still be achieved by designing the transmitter and receiver coils of a 2-coil system with high Q factor and

by using energy-efficient soft-switched power converter as a low-impedance power source. In [31], a transmitter coil (with a diameter of 30cm and a Q factor of 1270) and a receiver coil (with a diameter of 20cm and a Q factor of 1100) are used to transfer power of 105W over a transmission of 30cm. A system efficiency of 77% has been achieved in this case when the dimension of the transmitter coil and the transmission distance are the same. But if the transmission distance exceeds the transmitter coil dimension, the system energy efficiency will fall rapidly according to (10).

(ii) *Frequency-splitting*

As mentioned previously, most of the recent mid-range wireless power research based on the 4-coil systems adopts the maximum power transfer approach by matching the load impedance with the source impedance. The forward voltage gain S_{21} parameter is often used as an indicator for power transfer performance. The maximum power transfer approach, although not preferable from a system energy efficiency standpoint for short-range applications, can also be applied to a 2-coil system. A phenomenon recently observed in mid-range wireless power transfer research is called “frequency splitting”. Frequency splitting occurs when the conditions for the maximum power theorem cannot be met at the resonance frequency of the resonators within the over coupled region.

For a simplified equivalent circuit as shown in Fig.6 and assuming pure resistive source and load impedance, the reflected load resistance (R_R) is:

$$R_R = \frac{\omega_0^2 M_{12}^2}{R_L} = \frac{\omega_0^2 k_{12}^2 L_1 L_2}{R_L} \quad (11)$$

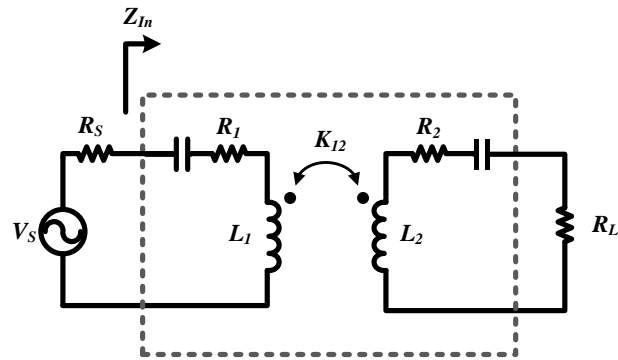

Fig.6 Equivalent circuit of a 2-coil system

Based on a 2-coil resonator system with parameters tabulated in Table I, Fig.7 shows the S-parameter S_{21} as a function of the mutual coupling coefficient and operating frequency. The mutual coupling coefficient κ_{12} is inversely proportional to the transmission distance d . So a decreasing κ_{12} means an increasing d . It can be seen from Fig.7 that, within the over-coupled region, maximum S_{21} occurs at two frequencies in this example. Beyond the critical coupling point, S_{21} reduces exponentially with an increasing d (i.e. a decreasing κ_{12}).

Table I Parameters for a 2-coil wireless power transfer system

Frequency	L_1	L_2	R_S	R_L
1 MHz	100 μ H	100 μ H	50 Ω	50 Ω

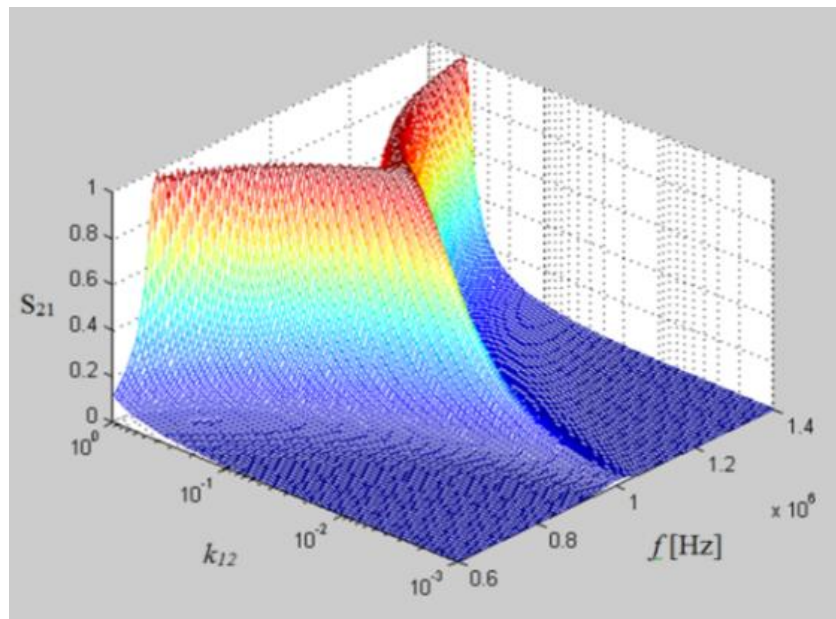
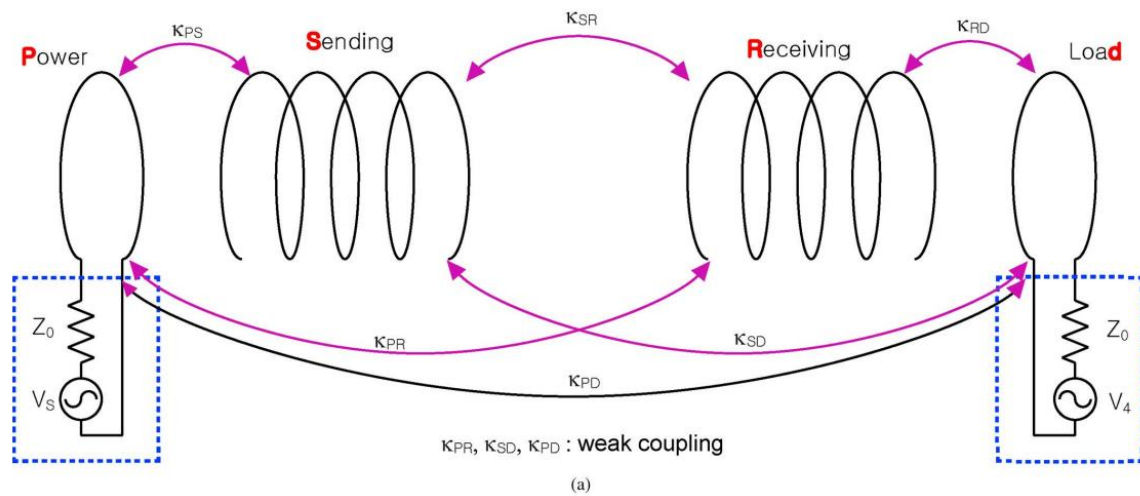

Fig.7 A plot of S_{21} as a function of mutual coupling coefficient and operating frequency for the example with parameters shown in Table I.

B. Wireless Systems with 2 Coil-Resonators and Input and Output Impedance Matching (or The 4-Coil Systems)



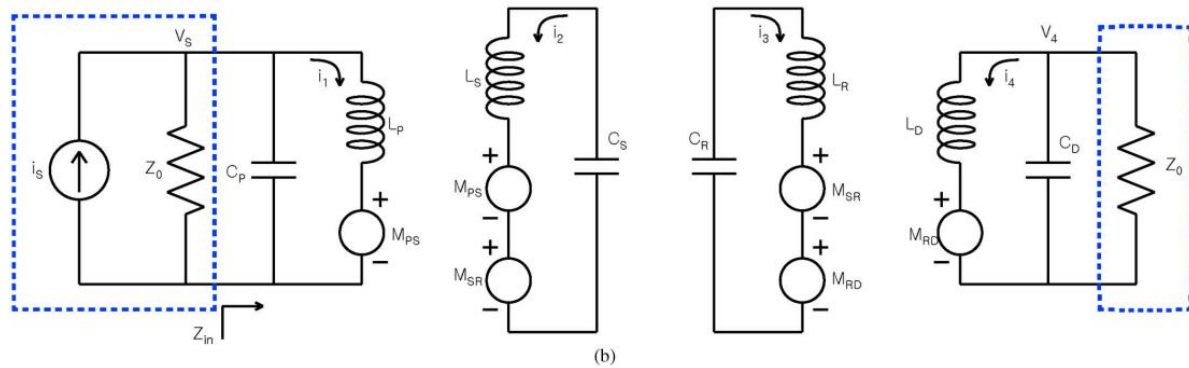

Fig.8 (a) Wireless power system with two coil-resonators, a power driving coil and a load coil, and (b) the equivalent circuits [36] – copyright IEEE

The use of intermediate resonators between the transmitter and receiver coils is not new. This idea was reported in 1998 in [32]. The recent interests in the 4-coil systems may be sparked off by the work reported in [27]. This structure involves a **P**ower driving coil, a **S**ending resonator, a **R**eceiving resonator and a **L**oad coil [27,33-41], as shown in Fig.8. While the coupled mode theory is used in [27], several references [33,34,36] have transformed the analysis using electric circuit theory, which is easily understood by electrical engineers. In addition, it has been pointed out [34] that the coupled mode theory does not include high order phenomena.

The use of the power driving coil and the load coil offer two extra mutual coupling coefficients for impedance matching (assuming that the mutual coupling of the driving loop and the load loop is negligible). Beside the mutual coupling coefficient between the Sending resonator and the Receiver resonator (κ_{SR}), the two extra coefficients are the mutual coupling coefficient between the **P**ower driving coil and the **S**ending resonator (κ_{PS}), and that between the **R**eceiving resonator and the **L**oad coil (κ_{RD}). Reference [36] contains a detailed circuit analysis of this 4-coil system and step-by-step explanations on how to match impedances in various stages in order to maximize power transfer. The 4-coil system provides 3 mutual coupling coefficients κ_{PS} , κ_{SR} and κ_{RD} which can be utilized to maximize the power transfer if the following condition can be met:

$$\frac{\kappa_{PS}\kappa_{RD}}{\kappa_{SR}} = 1 \quad (12)$$

The four coupled circuits in Fig.8b can be expressed in the form of the equivalent circuit of Fig.3. If the equation (12) can be satisfied, the input impedance Z_{in} and the reflected load impedance Z_o of Fig.8 will be matched [36], therefore meeting the condition for maximum power transfer theorem:

$$Z_o = Z_{in} \quad (13)$$

The 4-coil system provides a mechanism to extend the transmission distance. In order to maximize the transmission distance d for mid-range applications, the mutual coupling coefficient between the Sending resonator and the Receiving resonator (κ_{SR}) should be minimized. For example, if the transmission distance between the Sending and Receiving resonators are far apart so that $\kappa_{SR}=0.01$, by keeping $\kappa_{PS} =0.1$ and $\kappa_{RD}=0.1$, the conditions of (12) and (13) can be met. Therefore, appropriate adjustments of the two extra coefficients (κ_{PS} and κ_{RD}) allow a small κ_{SR} to be selected. A minimization of κ_{SR} represents a maximization of the transmission distance. This method is also demonstrated in a variable tuning method in [40]. Compared with the basic two-coil systems, the two extra mutual coupling coefficients (κ_{PS} and κ_{RD}) in the 4-coil systems provide extra freedom for extending the transmission distance by minimizing κ_{SR} through the use of (12). However, the impedance matching requirement of (13) also implies that such a system has its overall energy efficiency not higher than 50%, as indicated by (2). This inherent limitation could form a bottleneck of this 4-coil approach for mid- and high-power applications, unless energy efficiency is not a primary concern. Nevertheless, the 4-coil systems still offer a better solution (in terms of the system energy efficiency and transmission distance) than the 2-coil systems for mid-range application when the transmission distance is much larger than the transmitter coil dimension. The 4-coil system reported in [27], with a Sending resonator dimension of 30 cm and a transmission distance of 2m, achieves a system energy efficiency of 15%. For

a 2-coil system with the same coil dimensions and transmission distance, the system energy efficiency would be much less than 15%.

Frequency splitting phenomenon has been observed in the 4-coil systems [37]. The reason for such phenomenon is similar to that of the 2-coil systems when the concept of impedance matching is involved. Within the over-coupled range, near-constant power transfer can be achieved. Therefore, the power receiving load can be placed within a certain range, which is an important feature for medical implants [38]. To avoid the complication of frequency splitting, adaptive matching methods based on frequency tracking have been developed [39] [42]. In addition, it has been shown in [43] that antiparallel resonance loops can be used to eliminate the effects of frequency splitting so that constant resonance frequency can be retained.

So far, research in the 4-coil systems based on impedance matching (i.e. maximum power transfer theorem) has been demonstrated to be an effective means in extending the transmission distance at the expense of system energy efficiency. Recent research has covered new areas such as multiple transmitters [44,45] and multiple receivers [46-48]. This trend has the potential of opening a door to powering very low-power multiple sensor nodes in the vicinity of a single sending resonator. However, the authors have reservation on their application potentials for high power applications due to the limitation of the energy efficiency.

C. Wireless Systems with Relay Resonators

Operating at 15 kHz for power applications, the use of intermediate or relay resonators without using impedance matching have been reported in [32]. Operating at high frequency exceeding 10 MHz and based on a series of planar printed resonators, magneto-inductive waveguide has later been used for transmitting signal and low power [49-51]. The magneto-inductive waveguide adopts the impedance

matching method (i.e. obeying the maximum power transfer theorem). Therefore, the system energy efficiency of the magneto-inductive waveguide cannot exceed 50%.

The use of relay resonators between the Sending coil and Receiving coil has recently been tested [52-56] for improving system energy efficiency and extending the transmission distance. Some of these projects rely on high frequency operation above several megahertz and adopt the maximum power theorem. High operating frequency requires an RF amplifier or a sophisticated power electronic inverter as the power source. On the low-power front, an interesting use of the relay resonators in matrix forms have been proposed to develop body sensor network technology [57] for health-care and medical research, including continuous, non- invasive, and inexpensive monitoring of physiological variables.

D. Wireless Power Domino-Resonator Systems

Modified from the magneto-inductive waveguide concept, wireless domino-resonator systems have recently been investigated. The wireless domino-resonator systems are very flexible systems that allow the coil-resonators to be placed in various domino forms [58-61]. Unlike the magneto-inductive waveguide which has to operate at high frequency (typically in excess of several megahertz), the wireless domino-resonators systems work under the near-field magnetic coupling and maximum energy efficiency principles at sub-megahertz regime. They have been successfully tested at about 500 kHz, which is the typical switching of existing low-cost switched mode power converters. The sub-megahertz operation ensures that the switching power loss and the ac winding resistance can be kept low. In addition, new analyses on the optimization of the spacing of the resonators, the operating frequencies, the loads for achieving maximum energy efficiency have been conducted [60].

By placing the adjacent resonators in shorter distances, the strong mutual coupling and thus high energy efficiency can be achieved in the wireless domino-resonator systems. Domino-resonator

systems of straight-line, curved, circular and Y-shape (Figs.9a-9d) have been demonstrated [60]. One interesting feature of the domino-resonator system is that the power flow can be controlled with great flexibility. In addition, the power paths can be split or combined.

Research in the wireless domino-resonator systems is still in its initial stage. One possible application of the domino system is for wireless power transfer along a robotic arm made of non-ferromagnetic composite. A traditional robotic arm may use a power cable for power transfer from the upper arm to the lower arm. The frequent bending actions of the elbow joint and therefore the cable would adversely affect the reliability of the cable. Coil-resonators can be placed around the elbow joint so that no cable is needed between the upper and lower arms.

If superconductor is used to form a conducting wireless power guide, the domino-resonator system offers a highly (physically) flexible structure with simply air gaps between the adjacent resonators. This is in contrast to a relatively rigid structure of a traditional superconductor cable composed of a continuously solid superconductor strand covered first with an electrical insulation layer, then cooled with a liquid nitrogen layer and finally insulated with a thermal layer (along the entire solid cable structure).

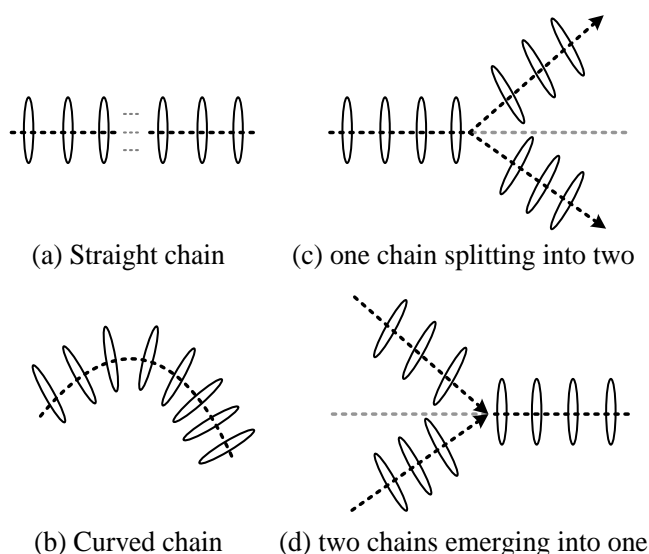

Fig.9 Examples of domino-resonator arrangements [60] - copyright IEEE

Due to the use of multiple coil-resonators, the cross coupling of the non-adjacent resonators cannot be ignored. It has been shown that such cross coupling effects could shift the optimal switching frequency away from the natural resonance frequency of the coil-resonators [58]. Because the domino-resonator systems are operating under the maximum energy efficiency principle, they are suitable for relatively high power applications.

Circular domino-resonator systems exhibit interesting behaviors because the power flow paths are in both clockwise and anti-clockwise directions. These behaviors can be studied with the superposition principle as reported in [59]. A photograph of a circular domino-resonator system powering an 18W compact fluorescent lamp is included in Fig.10.

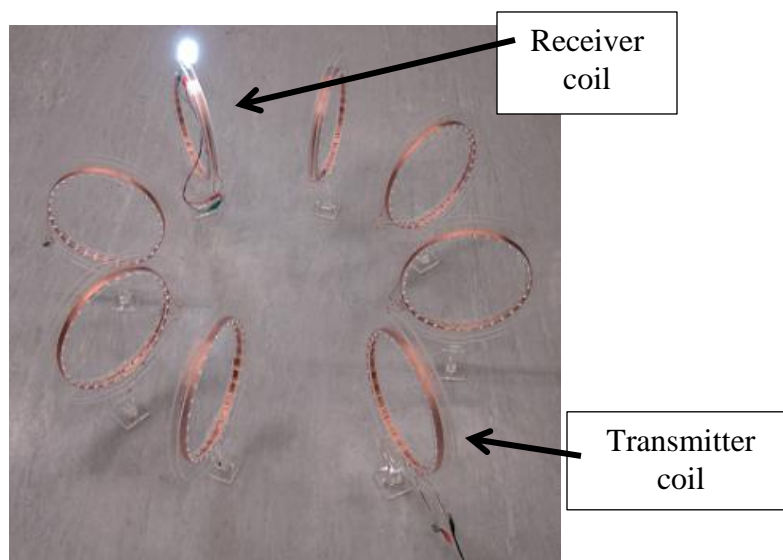

Fig.10 A photograph showing a circular domino-resonator system powering a 18W compact fluorescent lamp [59] – copyright IEEE

E. Other related technologies

- (i) Winding resistance reduction

In general, coil-resonators used for mid-range wireless power transfer do not require magnetic cores. Besides the power loss in the ac power source, the major factor of the total power loss in the entire system is the conduction loss in the windings of the resonators. Since most of the wireless power transfer systems are operated at a frequency of several megahertz, the conduction power loss arising from the ac resistance of the windings cannot be ignored. Ac winding resistance due to skin and proximity effects increases with operating frequency. Therefore, techniques that can reduce ac winding resistance are of paramount important if high energy efficiency is required. Reference [62] highlights a new spatial layout of a coil for reducing winding resistance. The special winding design is based on a surface spiral layout as shown in Fig.11. The thickness of the conduction layer is identical to the skin depth at the operating frequency for reducing the skin effects. The turns spiral over the surface for reducing the proximity effects. Using this winding design, it is reported in [62] that a high energy efficiency of 95% can be achieved for a transmission distance of 30cm for a 220W wireless power transfer system.

An alternative approach to reducing winding resistance is to use magnetoplated wires. Reference [63] illustrates a winding structure with the surface plated with magnetic thin film. Such technique has been demonstrated for reducing the ac resistance by 40% at 12MHz.

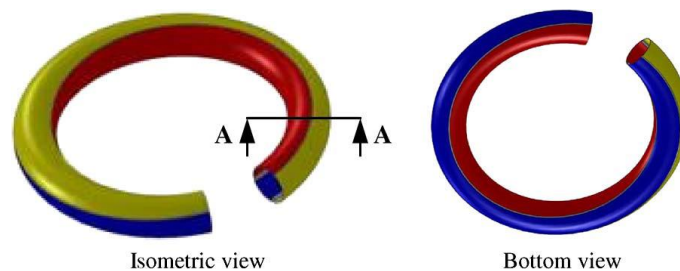

Fig.11 Winding based on surface spiral winding design [62] – copyright IEEE

(ii) Capacitor structures

Because of the requirements for tuning the resonance frequency, capacitor structures with adjustable capacitance have been studied. Coaxial-like capacitors vertically arranged and coaxially arranged with helical coils are reported in [64]. These structures make it flexible to control the capacitance and therefore the resonance frequency of the coil-resonators.

V. HUMAN EXPOSURE ISSUES

With increasing transmitted power level and transmission distance for mid-range wireless power transfer, one obvious concern is the safety issues related to human exposure of electric, magnetic and electromagnetic fields (EMF). Established adverse effects on health depend on the frequency and intensity of the EMF. In general, 100 kHz is a crossover the frequency below which the electrostimulation effects dominate, and above which the heating effects dominate. For short-range and low-power applications such as wireless charging pads for portable electronics (5W), the human exposure problems can be mitigated by using localized charging principle together with the use of the EM shields [18]. For short-range high-power applications such as wireless charging of electric vehicles (2kW), special magnetic designs can be adopted to guide the magnetic flux in order to minimize the leakage flux [65]. In order to comply with the human exposure regulations, an idea of detecting the presence of humans and lowering the power level when humans are in the very near vicinity has been suggested [66]. For short-range applications, only the leakage flux is of concern and therefore the EMF issues are less severe.

For mid-range wireless power transfer, the two guiding regulatory documents are (i) the ICNIRP Guidelines for Limiting Exposure to Time-varying Electric, Magnetic and Electromagnetic fields (1Hz to 100kHz) [67] and (up to 300GHz) [68] and (ii) IEEE Standard for Safety Levels with Respect to Human Exposure to Radio Frequency Electromagnetic Fields 3kHz to 300 GHz [69]. The typical human exposure limits of the ICNIRP and IEEE standards are shown in Fig.12 and Fig.13, respectively. The

ICNIRP regulations provide two different sets of limits for occupational exposure and for general public exposure, while the IEEE standard provides only one set of limits. For mid-range wireless power transfer, the majority of the work is conducted at or below 13.56 MHz. Within this frequency range, it can be observed from Fig.12 and Fig.13 that the maximum EMF levels for both the electric and magnetic fields become more stringent as the frequency increases.

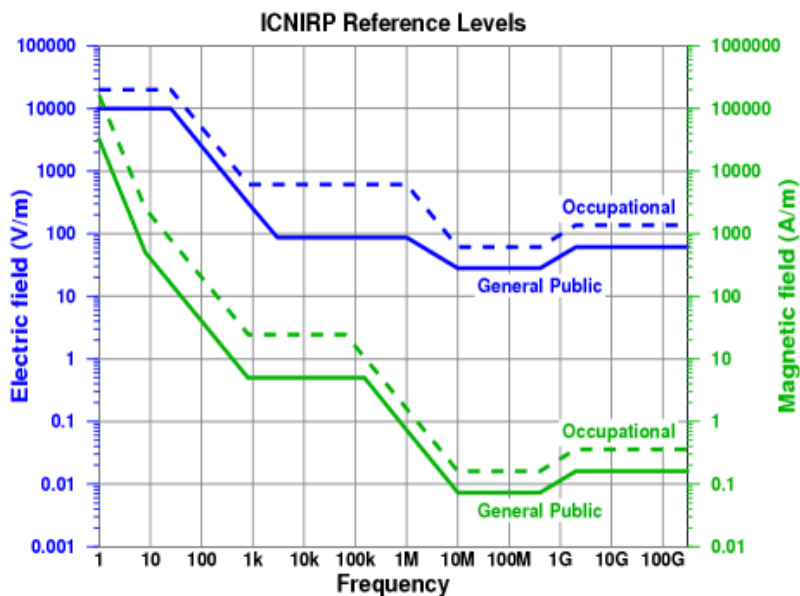

Fig.12 ICNIRP Reference levels for exposure to time-varying electric and magnetic fields

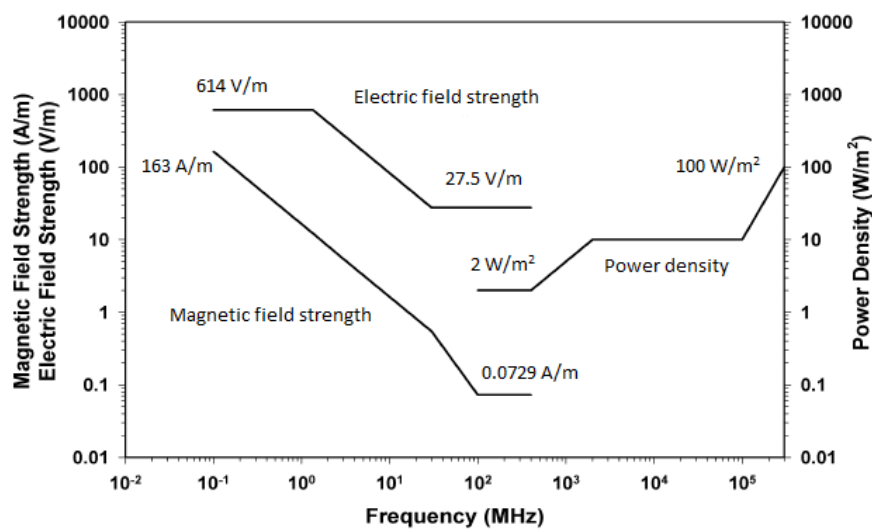

Fig.13 IEEE Reference levels for exposure to time-varying electric and magnetic fields – Copyright IEEE

Several tests have been reported to evaluate the EMF issues of mid-range wireless power transfer for the 4-coil systems. The report in [70] in fact sheds some light on the EMF issues of the 4-coil system reported in [27]. When 60W is transferred over 2m between the Sending resonator and the Receiving resonator under an operating frequency of 10MHz, the electric field in the position halfway between the two resonators is $E_{rms}=210\text{V/m}$, and the magnetic field is $H_{rms}=1\text{A/m}$. At the point of 20 cm from the resonator coil surface the electric field and magnetic field increase to $E_{rms}=1400\text{V/m}$ and $H_{rms}=8\text{A/m}$, respectively. Under the 10 MHz operation, the electric and magnetic field exposure levels are higher than their respective limits shown in Fig.13. In order to compile with the IEEE regulations, the author of [67] replaces the self-resonant coils with capacitively-load loops to confine the electric field in the capacitors and lowers the operating frequency to 1MHz (which further reduces the transmission efficiency).

A comprehensive investigation into the human exposure issues of the 4-coil system described in [37] has been reported in [71] using the anatomical whole-body models of both adult and child dimensions. The study focuses on the specific absorption rate (SAR) that can be determined based on the method detailed in [72]. The dimensions of the Driving and Load loops are 305mm (outer diameter), and of the Sending and Receiving resonators are 580mm (outer diameter, 6.1 turns). The anatomical models are exposed to the Sending resonator placed 10mm from the backs of the models. Tests are conducted with the Sending coil arranged in the coronal, axial and sagittal planes (Fig.15 and Fig.16 in the Appendix). Fig.14 shows the simulation results of the local specific absorption rates (SAR) of an adult model and a child model in two sagittal planes (centered and 75mm off center) reported in [71]. The most restrictive limits are found to be for the coronal exposure because the coil exposes the largest area of the body in this orientation. In the practical evaluation, a test loop is placed near the Sending coil so that the induced current can be measured and referenced to the transmitted power (Fig.16, Appendix). When a homogenous phantom is used for checking the SAR distribution, the resonance frequency is shifted from

theoretical value of 8 MHz to 6.7 MHz. This observation leads to an important point that the optimal frequency of a mid-range wireless power systems should be designed with the actual working environment in mind, as foreign objects could affect the effective magnetic coupling and magnetic field distribution. Based on the localized SAR limit of 2W/kg averaged over 10g of tissue stipulated in [69], a test loop current of $0.44A_{rms}$ is recorded when the 2W/kg limit is reached in the practical set, whilst a pre-recorded test loop current of 0.5A corresponds to a transmitted power of 45W. This important result is probably the first of this kind that successfully quantifies the order of magnitude of power that can be wirelessly transmitted over a mid-range distance in accordance with an international standard.

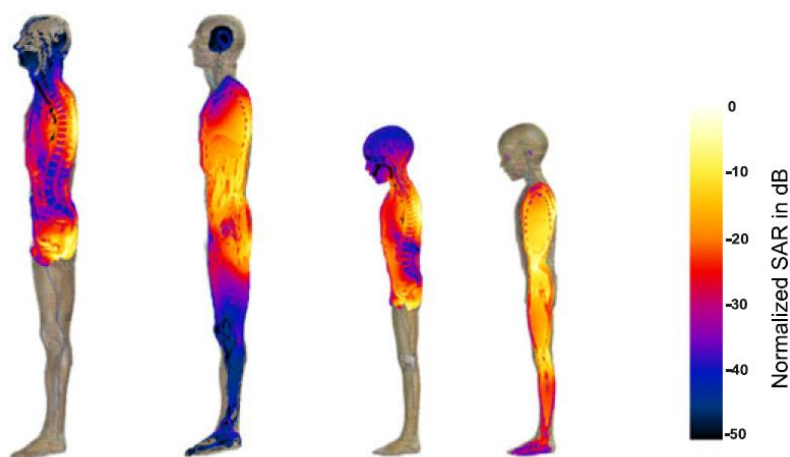

Fig.14 Local SAR of an adult model and a child model in two sagittal planes (centered and 75 mm off center) for coronal exposure [71] – Copyright IEEE.

VI. CONCLUSIONS

The recent progress on mid-range wireless power transfer is critically reviewed in this paper. The basic principles laid down by Tesla are highlighted. The system characteristics and key features of 2-coil systems, 4-coil systems, systems with relay resonators and domino-resonator systems are described. It can be seen that these recent mid-range wireless power transfer applications still apply the basic principles proposed by Tesla a century ago. The operating principles of wireless power can be classified into the maximum power transfer principle and the maximum energy efficiency principle. It should be

noted that the system energy efficiency achieved by the maximum power transfer theorem, which requires impedance matching, cannot exceed 50%. This is an inherent limitation of the maximum power transfer principle for mid-range wireless power transfer. Thus, a high transmission efficiency does not necessarily imply a high system energy efficiency.

In general, the 2-coil systems (adopting maximum energy efficiency principle) are suitable for short-range applications, and their energy efficiencies drop rapidly with mid-range transmission distance. The adjustments of the two extra mutual coupling terms in the 4-coil systems (adopting maximum power transfer principle) allow a flexible control of the impedance matching in the equivalent circuit and consequently enable the transmission distance to be maximized, at the expense of system energy efficiency. If relay resonators are allowed between the power source and the load, the wireless power systems with relay resonators or the wireless domino-resonator systems could be a good compromise in terms of extending the transmission distance and retaining reasonably high system energy efficiency, because these two kinds of systems can employ the maximum energy efficiency principle.

The human exposure (EMF) regulatory limits are likely to be the major limiting factors on the power capability of future mid-range wireless power transfer systems. Further research in mid-range wireless power transfer requires the combined efforts of the professionals and researchers in the areas of power electronics, control, RF, high-frequency magnetics, electromagnetic compatibility, material science and medical health care. Future challenges in mid-range wireless power transfer include further improvements in low-loss high-frequency power supplies and resonator designs with better energy efficiency for a given transmission distance, and new dynamic power and frequency control strategies for making wireless power systems adaptive to the presence and movements of foreign objects (including humans) for the compatibility with international EMF regulations.

VII APPENDIX

The orientations of the coronal, axial and sagittal planes are illustrated in Fig.15. The orientations of the resonator coil at 10mm distance to the body and the test loop for providing corresponding power measurements are shown in Fig.16 [71].

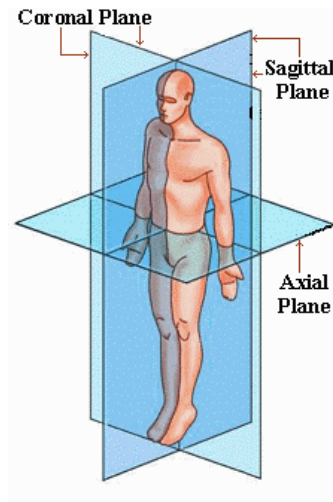

Fig.15 Orientations of the coronal, axial and sagittal planes

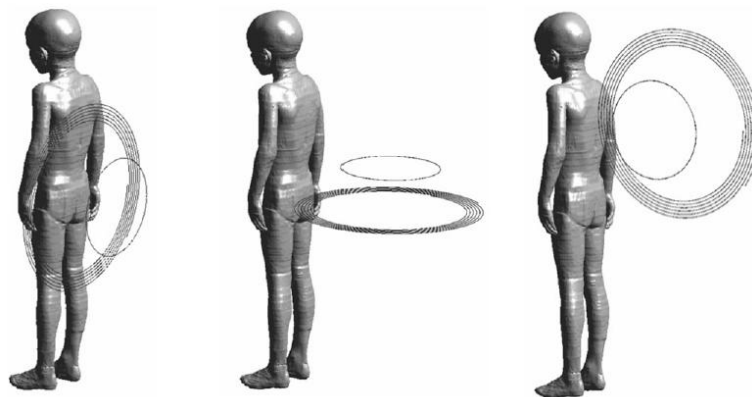

Fig.16 Orientations of the resonator coil at 10mm distance to the body (and the test loop for providing corresponding power information) (from left to right: coronal, axial and sagittal planes) [71] –Copyright IEEE

ACKNOWLEDGMENT:

This work was supported by the Hong Kong Innovation and Technology Fund (ITF) under Project ITS/284/11. The authors are grateful for the useful communications with Dr. Andreas Christ.

REFERENCES

- [1] N. Tesla, "Apparatus for transmitting electrical energy," U.S. Patent 1,119,732, Dec. 1, 1914.
- [2] Robert Lomas, *The man who invented the twentieth century – Nikola Tesla – Forgotten Genius of Electricity*. Headline 1999, ISBN 0 7472 6265 9, p. 146.
- [3] J. C. Schuder, H. E. Stephenson, and J. F. Townsend, "High level electromagnetic energy transfer through a closed chestwall," *IRE Int. Conv. Rec.*, pt.9, vol.9, pp. 119-126, 1961.
- [4] W. H. Ko, S. P. Liang, and C.D.F. Fung, "Design of rf-powered coils for implant instruments," *Med. Biol. Eng. Comput.*, vol. 15, pp. 634-640, 1977.
- [5] E. Hochmair, "System optimization for improved accuracy in transcutaneous signal and power transmission", *IEEE Trans. Biomedical Engineering*, vol. BME-31, no.2, pp. 177-186, Feb. 1984.
- [6] B. Choi, J. Nho, H. Cha, T. Ahn and S. Choi, "Design and implementation of low-profile contactless battery charger using planar printed circuit board windings as energy transfer device," *IEEE Trans. Industrial Electronics*, vol. 51, no. 1, pp. 140-147, Feb. 2004.
- [7] Y. Jang and M. M. Jovanovic, "A contactless electrical energy transmission system for portable-telephone battery chargers", *IEEE Trans. Industrial Electronics*, vol. 50, no. 3, pp. 520–527, Jun. 2003.
- [8] W.G. Hurley and J. Kassakian, "Induction heating of circular ferromagnetic plates", *IEEE Trans. Magnetics*, vol. 15, no. 4, pp. 1174-1181, Jul. 1979.
- [9] A.W. Green and J.T. Boys, "10 kHz inductively coupled power transfer-concept and control", in *Proc. ICPE-VSD*, 1994, pp. 694–699.

- [10] J.T. Boys, G.A. Covic and A.W. Green, “Stability and control of inductively coupled power transfer systems”, in *Proc. Electric Power Applications*, 2000, vol. 147, no. 1, pp. 37–43.
- [11] J.T. Boys, A.P. Hu and G.A. Covic, “Critical Q analysis of a current-fed resonant converter for ICPT applications”, *Electronics Letters*, vol. 36, no. 17, pp. 1440–1442, 2000.
- [12] G.A.J. Elliott, G.A. Covic, D. Kacprzak and J.T. Boys, “A New Concept: Asymmetrical Pick-Ups for Inductively Coupled Power Transfer Monorail Systems”, *IEEE Trans. Magnetics*, vol. 42, no. 10, pp. 3389–3391, 2006.
- [13] M.L.G. Kissin, J.T. Boys and G.A. Covic, “Interphase Mutual Inductance in Polyphase Inductive Power Transfer Systems”, *IEEE Trans. Industrial Electronics*, vol. 56, no. 7, pp. 2393–2400, 2009.
- [14] B. Choi, J. Nho, H. Cha, T. Ahn and S. Choi, “Design and implementation of low-profile contactless battery charger using planar printed circuit board windings as energy transfer device”, *IEEE Trans. Industrial Electronics*, vol. 51, no. 1, pp. 140-147, Feb. 2004.
- [15] Y. Jang and M. M. Jovanovic, “A contactless electrical energy transmission system for portable-telephone battery chargers”, *IEEE Trans. Industrial Electronics*, vol. 50, no. 3, pp. 520–527, Jun. 2003.
- [16] C.-G. Kim, D.-H. Seo, J.-S. You, J.-H. Park and B. H. Cho, “Design of a contactless battery charger for cellular phone”, *IEEE Trans. Industrial Electronics*, vol. 48, no. 6, pp. 1238-1247, Dec. 2001.
- [17] S.Y.R. Hui and W.C. Ho, “A new generation of universal contactless battery charging platform for portable Consumer Electronic equipment”, *IEEE Trans. Power Electronics*, vol. 20, no. 3, pp. 620–627, May 2005.

- [18] X. Liu and S.Y.R. Hui, "Simulation Study and Experimental Verification of a Contactless Battery Charging Platform with Localized Charging Features" *IEEE Trans. Power Electronics*, vol. 22, no.6, pp. 2202–2210, Nov. 2007.
- [19] S.Y.R. Hui, "Planar Inductive Battery Charging System", US Patent 7,576,514, 2009.
- [20] Wireless Power Consortium Website [online]. Available: <http://www.wirelesspowerconsortium.com>
- [21] I.J. Yoon and H. Ling, "Investigation of near-field wireless power transfer in the presence of lossy dielectric materials", *IEEE Trans. Antenna and Propagation*, vol. 61, no. 1, pp. 482-488, Jan. 2013.
- [22] C.K. Lee, W.X. Zhong and S.Y.R. Hui, "Recent progress in mid-range wireless power transfer", in *Proc. ECCE*, 2012, pp. 3819-3824.
- [23] A.S. Marincic, "Nikola Tesla and The Wireless Transmission of Energy", *IEEE Trans. Power Apparatus and Systems*, vol. PAS-101, no. 10, pp. 4064-4068, Oct. 1982.
- [24] L.P. Wheeler, *Tesla's contribution to high frequency*, Electrical Engineering, N.Y., Aug. 1943, p. 355.
- [25] [online] <http://www.tfcbooks.com/articles/witricity.htm>
- [26] T. K. Sarkar, R.J. Mailloux, A.A. Oliner, M. Salazar-Palma and D.L. Sengupta, "History of Wireless: Chapter 8. Nikola Tesla and His Contributions to Radio Development", John Wiley & Sons, 2006.
- [27] A. Kurs, A. Karalis, R. Moffatt, J. D. Joannopoulos, P. Fisher, and M. Soljacic, "Wireless power transfer via strongly coupled magnetic resonances," *Science*, vol. 317, no. 5834, pp. 83–86, Jul. 2007.
- [28] E. Waffenschmidt and T. Staring, "Limitation of inductive power transfer for consumer applications", in *Proc. EPE*, 2009, pp. 1-10.

- [29] J.O. Mur-Miranda, G. Fanti, Y. Feng, K. Omanakuttan, R. Ongie, A. Setjoadi and N. Sharpe, “Wireless Power Transfer Using Weakly Coupled Magnetostatic Resonators”, in *Proc. ECCE*, 2010, pp. 4179-4186.
- [30] T. Imura and Y. Hori, “Maximizing air gap and efficiency of magnetic resonant coupling for wireless power transfer using equivalent circuit and Neumann formula”, *IEEE Trans. Industrial Electronics*, vol. 58, no. 10, pp. 4746-4752, Oct. 2011.
- [31] M. Pinuela, D. Yates, S. Lucyszyn and P.D. Mitcheson, “Maximising DC to load efficiency for inductive power transfer”, *IEEE Trans. Power Electronics*, vol. 28, no. 5, pp. 2437-2447, May 2013.
- [32] J.T. Boys “Inductive power transfer across an extended gap” WO/1998/050993 filed 05-11-1998, published 12-11-1998
- [33] C.J. Chen, T.H. Chu, C.L. Lin, and Z.C. Jou, “A study of loosely coupled coils for wireless power transfer”, *IEEE Trans. Circuits and Systems – II: Express Briefs*, vol. 57, no. 7, pp. 536-540, Jul. 2010.
- [34] M. Kiani, and M. Ghovanloo, “The circuit theory behind coupled-mode magnetic resonance-based wireless power transmission,” *IEEE Trans. Circuits Systems – I*, vol. 59, no. 8, pp. 1-10, Aug. 2012.
- [35] Y.H. Kim, S.Y. Kang, S. Cheon, M.L. Lee, J.M. Lee and T. Zyung, “Optimization of wireless power transmission through resonant coupling”, in *Proc. SPEEDAM*, 2010, pp. 1069-1073.
- [36] S. Cheon, Y.H. Kim, S.Y. Kang, M. L. Lee, J.M. Lee, and T. Zyung, “Circuit-model-based analysis of a wireless energy-transfer system via coupled magnetic resonances”, *IEEE Trans. Industrial Electronics*, vol. 58, no. 7, pp. 2906-2914, Jul. 2011.

- [37] A. P. Sample, D.A. Meyer and J.R. Smith, "Analysis, experimental results and range adaptation of magnetically coupled resonators for wireless power transfer", *IEEE Trans. Industrial Electronics*, vol. 58, no. 2, pp. 544-554, Feb. 2011.
- [38] B.H. Waters, A. P. Sample, P. Bonde and J. R. Smith, "Power a ventricular assist device (VAD) with the free-range resonant electrical energy delivery (FREE-D) system", in *Proc. of the IEEE*, vol. 100, no. 1, pp. 138-149, Jan. 2012.
- [39] J. Park, Y. Tak, Y. Kim, Y. Kim, and S. Nam, "Investigation of adaptive matching methods for near-field wireless power transfer", *IEEE Trans. Antennas and Propagation*, vol. 59, no. 5, pp. 1769-1773, May 2011.
- [40] T. P. Duong and J.W. Lee, "Experimental results of high-efficiency resonant coupling wireless power transfer using a variable coupling method", *IEEE Microwave and Wireless Components Letters*, vol. 21, no. 8, pp. 442-444, Aug. 2011.
- [41] A. K. RamRakhyani, S. Mirabbasi and M. Chiao, "Design and optimization of resonance-based efficient wireless power delivery systems for biomedical implants", *IEEE Trans. Biomedical Circuits and Systems*, vol. 5, no. 1, pp. 48-63, Feb. 2011.
- [42] H. Hoang and F. Bien, "Maximizing efficiency of electromagnetic resonance wireless power transmission systems with adaptive circuits", in *Wireless Power Transfer – Principles and Engineering Explorations*, K.Y. Kim, InTech, Jan. 2012, pp: 207-225.
- [43] W.S. Lee, W.I. Son, K.S. Oh and J.W. Yu, "Contactless energy transfer systems using antiparallel resonant loops", *IEEE Trans. Industrial Electronics*, vol. 60, no. 1, pp. 350-359, Jan. 2013.
- [44] D. Ahn and S. Hong, "Effects of coupling between multiple transmitters or multiple receivers on wireless power transfer", *IEEE Trans. Industrial Electronics*, 2013, Early access: <http://ieeexplore.ieee.org/stamp/stamp.jsp?tp=&arnumber=6192319>

- [45] I.J. Yoon and H. Ling, "Investigation of near-field wireless power transfer under multiple transmitters", *IEEE Antennas and Wireless Propagation Letters*, vol. 10, pp. 662-665, 2011.
- [46] B.L. Cannon, J.F. Hoburg, D. Stancil and S.C. Goldstein, "Magnetic resonant coupling as a potential means for wireless power transfer to multiple small receivers", *IEEE Trans. Power Electronics*, vol. 24, no. 7, pp. 1819-1825, Jul. 2009.
- [47] A. Kurs, R. Moffatt and M. Solijacic, "Simultaneous mid-range power transfer to multiple devices", *Appl. Phys. Lett.* 96, 044102, 2010.
- [48] Y.H. Kim, S.Y. Kang, S. Cheon, M.L. Lee and T. Zyung, "Wireless power transmission to multi devices through resonant coupling", in *Proc. Int. conference on Electrical Machines & Systems*, Incheon, S. Korea, 2010, pp: 2000-2002.
- [49] R. Syms, E. Shamonina and L. Solymar, "Magneto-inductive waveguide devices", in *IEE Proc. Microwave, Antennas Propagation*, 2006, vol. 153, no. 2, pp. 111-121.
- [50] R. Syms, E. Shamonina, V. Kalinin and L. Solymar, "A theory of metamaterials based on periodically loaded transmission lines: Interaction between magnetoinductive and electromagnetic waves", *Journal of Applied Physics*, vol. 97, no. 064909, pp. 1-6, Mar. 2005.
- [51] R. Syms, L. Solymar, I. Young and T. Floume, "Thin-film magneto-inductive cables", *Journal of Physics D: Applied Physics*, 43 (2010) 055102 (7pp).
- [52] F. Zhang, S. Hackworth, W. Fu and M. Sun, "The relay effect on wireless power transfer using witrlicity", *IEEE Conference on Electromagnetic Field Computation*, Chicago, USA, May 2010.
- [53] F. Zhang, S. A. Hackworth, W. Fu, C. Li, Z. Mao, and M. Sun, "Relay effect of wireless power transfer using strongly coupled magnetic resonances," *IEEE Transactions on Magnetics*, vol. 47, no. 5, pp. 1478-1481, May 2011.

- [54] J.W. Kim, H.C. Son, K.H. Kim and Y.J. Park, "Efficiency analysis of magnetic resonance wireless power transfer with intermediate resonant coil", *IEEE Antennas and Wireless Propagation Letters*, vol. 10, pp. 389-392, 2011.
- [55] M. Kiani, U.M. Jow and M. Ghovanloo, "Design and optimization of a 3-coil inductive link for efficient wireless power transmission", *IEEE Trans. Biomedical Circuits and Systems*, vol. 5, no. 6, pp. 579-591, Dec. 2011.
- [56] X. Zhang, S.L. Ho and W.N. Fu, "Quantitative design and analysis of relay resonators in wireless power transfer system", *IEEE Trans. Magnetics*, vol. 48, no. 11, pp. 4026-4029, Nov. 2012.
- [57] F. Zhang, J. Liu, Z. Mao and M. Sun, "Mid-Range Wireless Power Transfer and Its Application to Body Sensor Networks", *Open Journal of Applied Sciences*, vol. 2, pp. 35-46, 2012.
- [58] C.K. Lee, W.X. Zhong and S.Y.R. Hui, "Effects of Magnetic Coupling of Non-adjacent Resonators on Wireless Power Domino-Resonator Systems", *IEEE Trans. Power Electronics*, vol. 27, no. 4, pp. 1905-1916, Apr. 2012.
- [59] W.X. Zhong, C.K. Lee and S.Y.R. Hui, "Wireless Power Domino-Resonator Systems with Non-coaxial axes and Circular Structures", *IEEE Trans. Power Electronics*, vol. 27, no. 11, pp. 4750-4762, Nov. 2012.
- [60] W.X. Zhong, C.K. Lee and S.Y.R. Hui, "General Analysis on the Use of Tesla's Resonators in Domino Forms for Wireless Power Transfer", *IEEE Trans. Industrial Electronics*, vol. 60, no. 1, pp. 261-270, Jan. 2013.
- [61] S.Y.R. Hui and W.X. Zhong, "Apparatus and Method for Wireless Power Transfer", Patent application PCT/IB2011/000050, Jan. 14, 2011.
- [62] S.H. Lee and R. D. Lorenz, "Development and validation of model for 95% efficiency 220W wireless power transfer over a 30-cm air gap", *IEEE Trans. Industry Applications*, vol. 47, no. 6, pp. 2495-2504, Nov./Dec. 2011.

- [63] T. Mizuno, S. Yachi, A. Kamiya and D. Yamamoto, "Improvement in Efficiency of Wireless Power Transfer of Magnetic Resonant Coupling Using Magnetoplated Wire", *IEEE Trans. Magnetics*, vol. 47, no. 10, pp. 4445-4448, Oct. 2011.
- [64] H.C. Son, J.W. Kim, D.H. Kim, K.H. Kim and Y.J. Park, "Self-resonant coil with coaxial-like capacitor for wireless power transfer", in *Proc. APMC*, Australia 2011, pp. 91-93.
- [65] M. Budhia, G. Covic and J. Boys, "Design and optimization of circular magnetic structures for lumped inductive power transfer systems", *IEEE Trans. Power Electronics*, vol.26, no.11, pp. 3096-3107, Nov. 2011.
- [66] M. Budhia, J. Boys, G. Covic and C.Y. Hang, "Development of a single-sided flux magnetic coupler for electric vehicle IPT charging systems", *IEEE Trans. Industrial Electronics*, vol. 60, no. 1, pp. 318-328, Jan. 2013.
- [67] "ICNIRP Guidelines for Limiting Exposure to Time-varying Electric, Magnetic and Electromagnetic fields (1Hz to 100kHz)", *Health Physics*, vol. 99, no. 6, pp. 818-836, Dec. 2010.
- [68] "ICNIRP Guidelines for Limiting Exposure to Time-varying Electric, Magnetic and Electromagnetic fields (up to 300GHz)", *Health Physics*, vol. 74, no. 4, pp. 494-522, 1998.
- [69] IEEE Standard for Safety Levels with Respect to Human Exposure to Radio Frequency Electromagnetic Fields 3kHz to 300 GHz, IEEE 2006.
- [70] A. Kurs, "Power transfer through strongly coupled resonances", M.Sc. Thesis, MIT, Sept. 2007, pp. 39-40.
- [71] A. Christ, M. Douglas, J. Roman, E. Cooper, A. Sample, B. Waters, J. Smith and N. Kuster, "Evaluation of wireless resonant power transfer systems with human electromagnetic exposure limits", *IEEE Trans. Electromagnetic Compatibility*, Early access: <http://ieeexplore.ieee.org/stamp/stamp.jsp?tp=&arnumber=6340322>

- [72] IEEE Recommended Practice for Measurements and Computations of Radio Frequency Electromagnetic Fields With Respect to Human Exposure to Such Fields, 100 kHz–300 GHz, IEEE Std C95.-2002 (R2008).