



Title	Application of linear magnetic gears for pseudo-direct-drive oceanic wave energy harvesting
Author(s)	Li, W; Chau, KT; Jiang, JZ
Citation	The IEEE International Magnetic Conference (INTERMAG2011), Taipei, Taiwan, 25-29 April 2011. In IEEE Transactions on Magnetics, 2011, v. 47 n. 10, p. 2624-2627
Issued Date	2011
URL	http://hdl.handle.net/10722/140220
Rights	Creative Commons: Attribution 3.0 Hong Kong License

Application of Linear Magnetic Gears for Pseudo-Direct-Drive Oceanic Wave Energy Harvesting

Wenlong Li, K. T. Chau, and J. Z. Jiang

Department of Electrical and Electronic Engineering, The University of Hong Kong, Hong Kong, China

This paper proposes a linear permanent magnet (PM) machine for direct-drive wave energy harvesting by using a linear magnetic gear. The proposed machine consists of a linear magnetic gear cascaded with a linear PM generator in which the high-speed mover of the linear magnetic gear and the translator of the PM generator artfully shares with the same shaft. In short, the slow reciprocating wave motion is directly captured by the low-speed mover of the gear, and then amplified in speed via the gear to actuate the generator, hence producing higher output voltage. By using finite element analysis, the steady and dynamic performances are analyzed, which confirms that the proposed machine can offer higher power density and higher efficiency than its counterpart.

Index Terms—Linear magnetic gear, linear permanent magnet generator, pseudo-direct-drive, wave energy harvesting.

I. INTRODUCTION

RENEWABLE energy is increasingly considered as a decisive role in the future energy system. Among those viable clean and renewable energy resources, namely the hydro, wind, solar, geothermal, and wave, the wave energy is promising but immature. One of the main problems is the lack of suitable generators to efficiently and effectively harness the wave energy. Basically, there are two types of wave power-generation systems, namely the rotational generator type and the linear generator type [1]. Since the rotational generator type inevitably desires complicated mechanisms such as water turbines or hydraulic pumps to convert linear reciprocating wave motion to rotational motion, it suffers from the problems of regular maintenance, low efficiency, low power density, and high cost. The linear generator type utilizes the linear machine to directly harness the wave motion, thus eliminating the bulky linear-to-rotary transmission mechanism and the associated power losses [2]. However, because of the low-speed nature of reciprocating wave motion (typically 0.5 m/s), the direct-drive linear generator needs to adopt low-speed design, thus significantly degrading its power density.

Recently, a coaxial magnetic geared outer-rotor permanent magnet (PM) machine has been developed for wind power generation [3], which can match with the low-speed nature of wind turbines (typically 150 rpm) and allow for high-speed machine design. By extending this idea to linear morphology, the integration of linear magnetic gear [4] and linear generator can simultaneously provide matching with the low-speed wave motion and adopt the high-speed generator design, thus both the power density and efficiency of the linear integrated machine can be greatly improved.

This paper proposes a new linear integrated PM machine, which artfully integrates a linear magnetic gear and a linear PM generator, for direct-drive wave power generation. Hence, the slow reciprocating wave motion can be directly captured, while the generator can adopt high-speed design to maximize its power density and minimize its raw material cost.

Manuscript received February 18, 2011; accepted April 17, 2011. Date of current version September 23, 2011. Corresponding author: W. Li (e-mail: wlli@eee.hku.hk).

Color versions of one or more of the figures in this paper are available online at <http://ieeexplore.ieee.org>.

Digital Object Identifier 10.1109/TMAG.2011.2146233

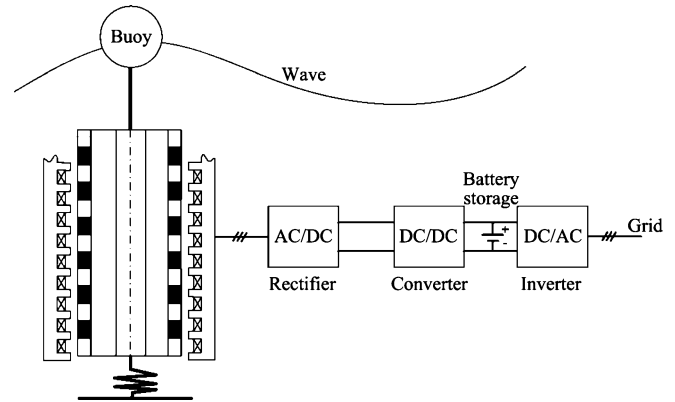

Fig. 1. Configuration of heaving-buoy wave energy harvesting system.

II. CONFIGURATION

Fig. 1 depicts the configuration of the heaving-buoy wave energy harvesting system that consists of the linear generator, the mechanical accessory, and the power processing units. The motion of the generator translator is governed by

$$F_b + F_s + F_{em} + mg = m \frac{d^2x}{dt^2} \quad (1)$$

where F_b is the force of the buoy, F_s is the force of the spring, F_{em} is the generator electromagnetic force, g is the gravitational acceleration, m is the mass of the translator, and x is the displacement of the translator.

For natural wave motion, the buoy force is huge while the frequency is very low. Thus, the linear generator needs to offer high force density and operate at low speeds.

A. Linear PM Synchronous Generator

The linear PM generator has been identified to be viable for direct-drive wave power generation due to its high efficiency [2]. For a conventional PM synchronous generator, the force density can be analytically derived. When the magnetic permeability of stator iron core is assumed to be infinite while the magnetic flux leakage in the stator back iron is negligible, the average air-gap flux density can be expressed as

$$B_g = B_r \frac{h_m}{kh_m + \mu_r k_c h_{ag}} \frac{4}{\pi} \sin\left(\frac{\tau_m \pi}{\tau} \frac{\pi}{2}\right) \quad (2)$$

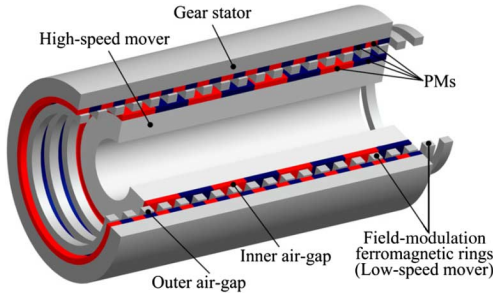

Fig. 2. Configuration of linear magnetic gear.

where B_r is the PM remanence, μ_r is the PM recoil permeability, h_m is the PM height, h_{ag} is the air-gap length, k is the leakage coefficient, k_c is the Carter coefficient, τ_{lm} is the PM length, and τ is the pole-pitch. Consequently, the developed thrust force per pole-pitch is given by

$$F_x = B_g S_f A_s J l \quad (3)$$

where S_f is the slot fill factor, A_s is the slot area, J is the current density, and l is the stack length. Under natural cooling, the current density is limited to 10 A/mm^2 . When the slot fill factor is set to 0.7 and the PM remanence is selected at 1.1 T, the force density can be calculated by using (3), which gives the value of 0.5 MN/m^3 .

B. Linear Magnetic Gear

The magnetic gear is an electromechanical device that can realize the mechanical gear functions such as torque transmission and speed reduction. Due to the noncontact feature, it takes advantages of no mechanical wear and tear, low acoustic noise, physical isolation between moving parts, and inherent overload protection. In the past decades, various configurations of magnetic gears and gearboxes have been developed [5], [6]. The linear magnetic gear is actually extended from its rotational counterpart.

As shown in Fig. 2, the linear magnetic gear is composed of a stator attached with PM poles, a low-speed mover inserted with ferromagnetic modulation rings, a high-speed mover also attached with PM poles, and two air gaps. When the low-speed mover is pushed or pulled by the external force, the corresponding ferromagnetic rings modulate the flux produced by the PM pole-pairs in the stator and the flux produced by the PM pole-pairs in the high-speed mover. The corresponding relationships can be directly borrowed from its rotational counterpart [7], [8]

$$N_{lm} = N_s + N_{hm} \quad (4)$$

$$G_r = \frac{v_{hm}}{v_{lm}} = \frac{N_{lm}}{N_{hm}} \quad (5)$$

where N_{lm} is the number of active ferromagnetic modulation rings in the low-speed mover, N_s is the number of active PM pole-pairs in the stator, N_{hm} is the number of active PM pole-pairs in the high-speed mover, G_r is the gear ratio, v_{hm} is the velocity of the high-speed mover, and v_{lm} is the velocity of the low-speed mover.

The maximum thrust force developed on the low-speed mover is given by [9]

$$F_{1\max} = \frac{8}{\pi} N_{lm} \lambda_1 l H_{hc} H_{lc} h_{hpm} h_{lpm} \quad (6)$$

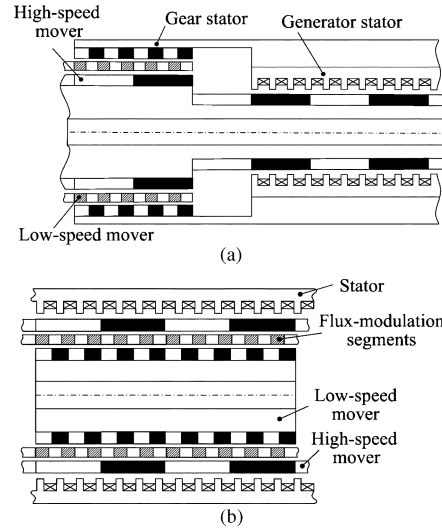

Fig. 3. Linear magnetic-gear machine. (a) Series integration. (b) Parallel integration.

where N_{lm} is the number of PM pole-pairs on the low-speed mover, λ_1 is the fundamental magnetic permeance, l is the stack length, H_{hc} and h_{hpm} are the coercive force and magnet thickness of PMs on the high-speed mover, respectively, and H_{lc} and h_{lpm} are the coercive force and magnet thickness of PMs on the low-speed mover, respectively. Consequently, the force density of the linear magnetic gear can be calculated as 1.6 MN/m^3 , which is about three times that of a linear PM synchronous machine. Thus, by integrating a linear magnetic gear into a linear PM synchronous machine, the overall force density can be greatly improved.

C. Linear Magnetic-Geared Machine

Fig. 3 shows two possible ways to combine the linear magnetic gear with the linear PM machine, namely the series integration and the parallel integration. In the series integration, the gear and the machine share the same shaft, and their magnetic circuits can be designed independently. In the parallel integration, the magnetic gear and the machine share the high-speed mover, thus a smaller volume can be achieved. However, the parallel integration usually involves three air gaps, so the configuration becomes very complicated. Therefore, the series integration is adopted in this design. Fig. 4 shows the structure of the proposed machine, which consists of a linear magnetic gear cascaded with a linear PM generator, thus artfully sharing with the same shaft (the high-speed mover of the gear and the translator of the generator). The low-speed mover of the magnetic gear is directly coupled with the buoy, which rises up and falls down along with wave propagation. The speed of the high-speed mover or the translator is thus amplified by a factor of the gear ratio. Therefore, the proposed system can directly capture the slow reciprocating wave motion while enabling high-speed generator operation.

The tubular structure is adopted for both the linear magnetic gear and the linear PM generator. Compared to the flat structure, the tubular one possesses a number of merits: higher space utilization, lesser leakage flux, larger thrust force density, no end-windings, and no radial force exerting on the bearings. The key design data of this linear magnetic-gear machine are listed in Table I.

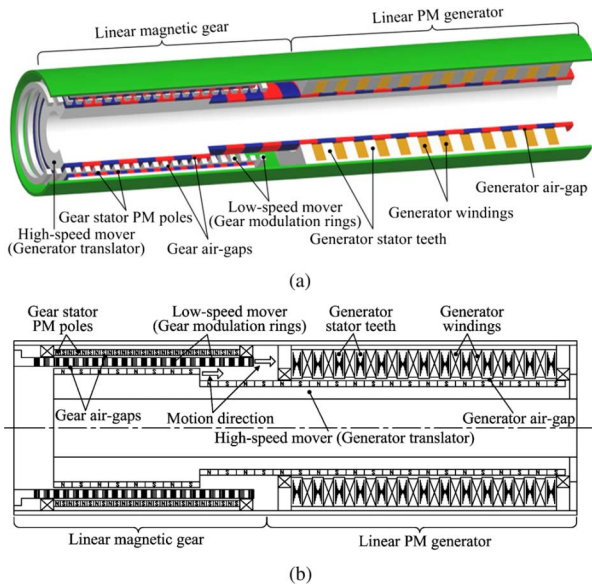

Fig. 4. Proposed machine system. (a) Solid model. (b) Schematic.

TABLE I
DESIGN DATA OF LINEAR MAGNETIC-GEARED MACHINE

Gear stator outside diameter	120 mm
Gear stator inside diameter	100 mm
Gear axial length of stator	127.3 mm
Gear low-speed mover outside diameter	98 mm
Gear low-speed mover inside diameter	86 mm
Axial length of low-speed mover	150 mm
Gear high-speed mover outside diameter	84 mm
Gear high-speed mover inside diameter	40 mm
Axial length of high-speed mover	100 mm
Air-gap length	1.0 mm
No. of active pole-pairs in stator	11
No. of active ferromagnetic rings in low-speed mover	15
No. of active pole-pairs in high-speed mover	4
PM remanence	1.2 T
No. of phases	3
Rated voltage	63 V
Generator stator inside diameter	68 mm
Generator stator axial length	181.5 mm
Generator translator outside diameter	66 mm
Generator translator inside diameter	40 mm
Generator translator axial length	250 mm
Overall axial length	350 mm
Total PM volume	461.6 cm ³
Total iron core volume	2007.0 cm ³
Total copper winding volume	236.87 cm ³
Total volume	3958.4 cm ³

III. PERFORMANCE ANALYSIS

In order to assess the performances of the proposed machine, both steady and dynamic analyses are carried out by using the finite element method (FEM).

A. Steady Analysis

Fig. 5 shows the magnetic field distribution of the proposed machine at no-load condition. It can be found that the corresponding linear magnetic gear and the linear PM generator are

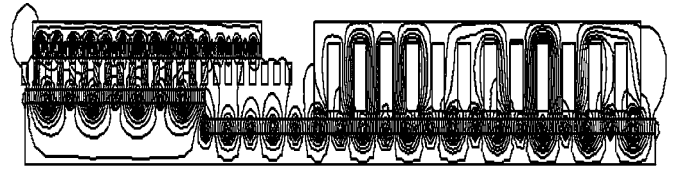

Fig. 5. Magnetic field distribution of the proposed machine.

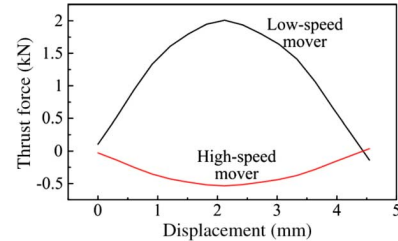

Fig. 6. Static thrust force waveform of linear magnetic gear part.

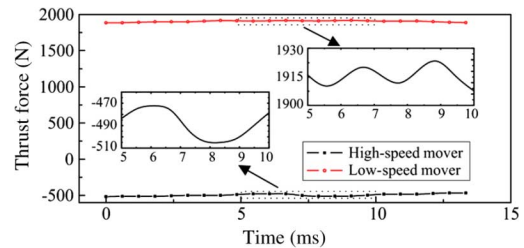

Fig. 7. Force transmission capability of linear magnetic gear part.

only mechanical-coupled and their magnetic circuits are almost independent, which can significantly ease the electromagnetic design. Fig. 6 depicts the static thrust force waveform of the gear when the low-speed mover travels one pole-pitch and the high-speed mover is fixed. It can be observed that the low-speed mover thrust force of up to 2 kN and the high-speed mover thrust force of up to 500 N can be developed. When the low-speed mover travels at 1 m/s and the high-speed mover travels at 3.75 m/s, the steady performance of proposed machine can be obtained. Fig. 7 shows the force transmission characteristics of the gear. The thrust force of the low-speed mover is about 3.8 times that of the high-speed mover. Moreover, it can be observed that the force ripples of the low-speed mover and high-speed mover are within 3% and 6%, respectively, which are very acceptable. Moreover, Fig. 8 shows the no-load electromotive force (EMF) of the generator, which can achieve a peak value of 110 V.

B. Dynamic Analysis

To assess the dynamic performance of the proposed machine, a time-varying sinusoidal buoy force is exerted on the low-speed mover as shown in Fig. 9(a), while the machine terminals are connected to a resistance load of 20 Ω . As shown in Fig. 9(b), the speeds of the two movers vary accordingly. Due to the magnetic gearing effect, the speed of the high-speed mover is 3.75 times that of the low-speed mover, thus a low-speed force is converted to a high-speed force. As shown in Fig. 9(c), the instantaneous EMF is proportional to the speed of the high-speed mover. Fig. 9(d) shows the total power losses in which the core loss is higher than the copper loss. On the other hand, a conventional low-speed linear PM synchronous machine, which has the same

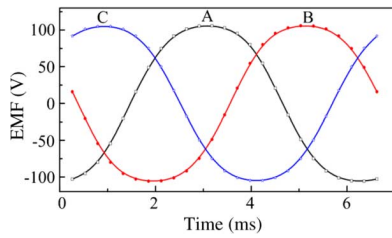

Fig. 8. Induced no-load EMF waveforms of linear PM generator part.

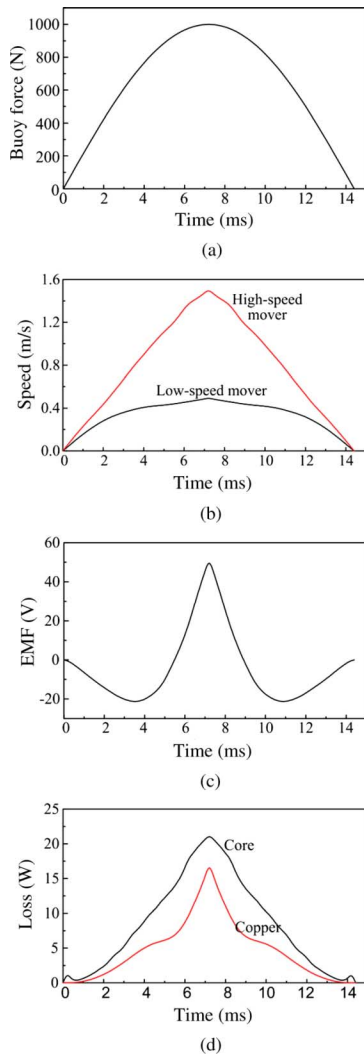

Fig. 9. Dynamic responses of proposed machine. (a) Buoy force. (b) Mover speeds. (c) Induced EMF. (d) Power losses.

power rating as the proposed one, is analyzed and simulated under the same condition. The conventional machine has about four times volume as the proposed one. The required volumes of PMs, iron cores, and copper windings are respectively 167%, 214%, and 271% of the proposed one, resulting in a much higher cost. The corresponding power losses are shown in Fig. 10. It can be found that its core loss is similar to that of the proposed machine, but the copper loss is much higher. Therefore, by in-

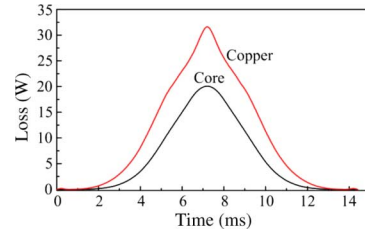

Fig. 10. Power losses of conventional linear PM synchronous machine.

corporating the linear magnetic gear into the linear PM generator, the overall cost can be reduced while the system efficiency and power density can be improved.

IV. CONCLUSION

This paper has presented a linear PM synchronous machine integrated with a linear magnetic gear for direct-drive wave power generation. By artfully coupling the linear magnetic gear and the linear PM generator that the high-speed mover of the gear and the translator of the generator share with the same shaft, the proposed machine can directly capture the slow reciprocating wave motion and adopt high-speed generator design. Both steady and dynamic analyses verify that the proposed machine has the advantages of lower cost, higher efficiency, and higher power density than the conventional low-speed linear PM synchronous machine for direct-drive wave energy harvesting.

ACKNOWLEDGMENT

This work was supported in part by the Hong Kong Research Grants Council, Hong Kong Special Administrative Region, China, under Project No. HKU710710E.

REFERENCES

- [1] A. Muetze and J. G. Vining, "Ocean wave energy conversion—A survey," in *Proc. IEEE Ind. Appl. Conf.*, 2006, pp. 1410–1417.
- [2] H. Polinder, B. C. Mecrow, A. G. Jack, P. Dickinson, and M. A. Mueller, "Conventional and TFPM linear generators for direct-drive wave energy conversion," *IEEE Trans. Energy Convers.*, vol. 20, no. 2, pp. 260–267, Jun. 2005.
- [3] L. Jian, K. T. Chau, and J. Z. Jiang, "A magnetic-gear outer-rotor permanent-magnet brushless machine for wind power generation," *IEEE Trans. Ind. Appl.*, vol. 45, no. 3, pp. 954–962, May–Jun. 2009.
- [4] K. Atallah, J. Wang, and D. Howe, "A high-performance linear magnetic gear," *J. Appl. Phys.*, vol. 97, pp. 10N516:1–10N516:3, 2005.
- [5] C. C. Huang, M. C. Tsai, D. G. Dorrell, and B. J. Lin, "Development of a magnetic planetary gearbox," *IEEE Trans. Magn.*, vol. 44, no. 3, pp. 403–412, Mar. 2008.
- [6] L. Jian, K. T. Chau, Y. Gong, J. Z. Jiang, C. Yu, and W. Li, "Comparison of coaxial magnetic gears with different topologies," *IEEE Trans. Magn.*, vol. 45, no. 10, pp. 4526–4529, Oct. 2009.
- [7] K. T. Chau, D. Zhang, J. Z. Jiang, C. Liu, and Y. J. Zhang, "Design of a magnetic-gear outer-rotor permanent-magnet brushless motor for electric vehicles," *IEEE Trans. Magn.*, vol. 43, no. 6, pp. 2504–2506, Jun. 2007.
- [8] K. T. Chau, D. Zhang, J. Z. Jiang, and L. Jian, "Transient analysis of coaxial magnetic gears using finite element comodeling," *J. Appl. Phys.*, vol. 103, no. 7, pp. 07F101:1–07F101:3, 2008.
- [9] W. Li, K. T. Chau, and J. Li, "Simulation of a tubular linear magnetic gear using HTS bulks for field modulation," *IEEE Trans. Appl. Supercond.*, vol. 21, no. 3, pp. 1167–1170, Jun. 2011.