



Title	DNA marker haplotype association with pancreatic sufficiency in cystic fibrosis
Author(s)	Kerem, BS; Buchanan, JA; Durie, P; Corey, ML; Levison, H; Rommens, JM; Buchwald, M; Tsui, LC
Citation	American Journal Of Human Genetics, 1989, v. 44 n. 6, p. 827-834
Issued Date	1989
URL	http://hdl.handle.net/10722/42290
Rights	American journal of human genetics. Copyright © University of Chicago Press.

DNA Marker Haplotype Association with Pancreatic Sufficiency in Cystic Fibrosis

Bat-sheva Kerem,* Janet A. Buchanan,* Peter Durie,†,|| Mary L. Corey,‡
Henry Levison,‡,|| Johanna M. Rommens,* Manuel Buchwald,* § and Lap-Chee Tsui*, §

*Department of Genetics, Research Institute, and Divisions of †Gastroenterology and ‡Respiratory Diseases, Department of Pediatrics, Hospital for Sick Children; and §Departments of Medical Genetics and Medical Biophysics and ||Department of Pediatrics, University of Toronto, Toronto

Summary

Patients with cystic fibrosis (CF) generally suffer from chronic obstructive lung disease, pancreatic insufficiency (PI), and a number of other exocrine malfunctions. Approximately 15% of CF patients are, however, pancreatic sufficient. To investigate whether the two clinical subgroups, PI and pancreatic sufficiency (PS), are caused by different CF mutant alleles, we have performed linkage disequilibrium and haplotype association analysis with three DNA markers that are tightly linked to the CF locus. The study showed that the allelic and haplotype distributions for these RFLPs are significantly different between the two groups. The data suggest that most of the CF-PI patients are probably descendants of a single mutational event at the CF locus and that the CF-PS patients resulted from multiple, different mutations. While final interpretation of these data awaits molecular cloning of the CF gene, the information on haplotype association in CF may be useful in genetic counseling and disease prognosis, in identifying the gene itself, and in defining the mutations.

Introduction

Cystic fibrosis (CF) is the most common genetic disease in the Caucasian population; it is inherited as an autosomal recessive trait with an estimated carrier frequency of 1/25 (Talamo et al. 1983). The incidence of CF in other populations is rare. The clinical expression of CF is heterogeneous; it usually comprises chronic obstructive lung disease and malfunction of exocrine glands leading to pancreatic enzyme insufficiency (PI), but all patients show elevated electrolyte concentration in the sweat. Approximately 15% of CF patients have sufficient pancreatic exocrine function for normal digestion (pancreatic sufficiency [PS]) and do not require pancreatic enzyme supplements with meals. CF-PS patients have a far superior overall prognosis than do those patients with PI (Gaskin et al. 1982), with improved survival, pulmonary function, and growth. Despite prog-

ress in perinatal diagnosis and medical care, the primary defect in CF is still unknown.

"Reverse genetics" (Orkin 1986) is now a widely used approach in studying diseases that are poorly defined biochemically. Recent successes with this approach include cloning of the genes responsible for Duchenne muscular dystrophy, chronic granulomatous disease, and retinoblastoma (reviewed by Orkin 1986). For CF, genetic linkage studies have enabled mapping of the disease locus to chromosome 7, band q31-q32 (reviewed by Tsui et al. 1986a; Spence and Tsui 1988). Several DNA markers, including *MET* (White et al. 1985), *D7S8* (Wainwright et al. 1985), *D7S23* (Estivill et al. 1987a) and *D7S122/D7S340* (Rommens et al. 1988a), are tightly linked to the CF locus. These markers span approximately 1.5 million bp (mb), and their order is *MET-D7S340-D7S122-D7S23-CF-D7S8*, as determined by long-range restriction mapping and family studies (Beaudet et al. 1986; Berger et al. 1987; Drumm et al. 1988; Farrall et al. 1988; Lathrop et al. 1988; Poustka et al. 1988; Rommens et al. 1988b).

While studies are attempting to identify the gene responsible for CF, several important observations have been made concerning the genetics of the disease, on

Received December 9, 1988; revision received February 9, 1989.

Address for correspondence and reprints: Lap-Chee Tsui, Ph.D., Department of Genetics, Hospital for Sick Children, 555 University Avenue, Toronto, Ontario M5G 1X8, Canada.

© 1989 by The American Society of Human Genetics. All rights reserved. 0002-9297/89/4406-0008\$02.00

the basis of tightly linked DNA markers and their haplotypes. Linkage disequilibrium has been noted between CF and the markers *MET* (Beaudet et al. 1986), *D7S8* (Beaudet et al. 1986), *D7S23* (Estivill et al. 1987a, 1987b), and *D7S122* (Rommens et al. 1988a), providing additional means for mapping the CF locus. Strong DNA marker haplotype association with CF has also been detected (Estivill et al. 1987a, 1987b; Rommens et al. 1988a; Beaudet et al. 1989; Cutting et al. 1989; J. M. Rommens, M. C. Iannuzzi, B. Kerem, G. Melmer, M. L. Drumm, D. Kennedy, N. Plavsic, D. Markiewicz, R. Rozmahel, J. L. Cole, M. Buchwald, F. S. Collins, and L.-C. Tsui, unpublished data) suggesting that most CF patients carry mutations with a common, single origin.

In view of the clinical heterogeneity in CF, however, it is possible that some of the varied disease phenotypes are due to different mutations at the CF locus. In support of this notion, almost complete concordance of PI or PS has been noted among patients within the same family in a study of 63 families with two or more affected children in the Toronto Clinic (Corey et al., in press). Furthermore, both CF-PI and CF-PS mutations are tightly linked to the same genetic markers on chromosome 7 (Tsui et al. 1986a; Tsui and Buchwald 1988). To provide further support to our hypothesis that PI and PS are due to different mutant alleles at the CF locus, we have analyzed linkage disequilibrium and haplotype association in these two groups of patient families by using RFLPs closely linked to the CF locus. These markers span 120 kbp around *D7S340*, *D7S122*, and *D7S23* (Rommens et al. 1988b; J. M. Rommens, M. C. Iannuzzi, B. Kerem, G. Melmer, M. L. Drumm, D. Kennedy, N. Plavsic, D. Markiewicz, R. Rozmahel, J. L. Cole, M. Buchwald, F. S. Collins, and L.-C. Tsui, unpublished data). A preliminary report of this work has been presented at a previous meeting (Buchanan et al. 1988).

Material and Methods

Patient Ascertainment

The primary cohort of 46 Canadian CF families each with two or more affected children has been described elsewhere (Tsui et al. 1986b). Patient diagnosis was confirmed by typical clinical findings of pulmonary and/or gastrointestinal disease and by abnormal sweat chloride test results. Of the 46 families, 27 were from the Toronto clinic and 19 were from other clinics in Canada. Pancreatic function was assessed in the Toronto clinic according one or more of three methods: (1) fat

balance studies, which involved 3–5-day stool collection, accurate weighing, recording of dietary fat intake, and subsequent analysis of fecal fat losses (van de Kamer et al. 1949); (2) direct analysis of pancreatic secretions by quantitative pancreatic stimulation test (Gaskin et al. 1984); and (3) measurement of serum levels of immunoreactive pancreatic cationic trypsinogen (Durie et al. 1986). Patients were considered to have PI if fecal fat losses, expressed as a percentage of dietary fat intake, exceeded 7% (or 15% in the case of infants <6 mo of age). The relationship between fecal balance studies and the quantitative pancreatic stimulation test has been established elsewhere (Gaskin et al. 1984). CF-PI patients with documented fat malabsorption had pancreatic colipase output of <100 U/kg/h, whereas CF-PS patients had higher levels. Similarly, the serum trypsinogen test has been shown to be a valid method for assessing pancreatic function (Durie et al. 1986); 94% of older CF-PI patients (with documented fat malabsorption) showed serum trypsinogen values below the normal range (i.e., <16.6 ng/ml) established for control subjects. For the purpose of this study, serum trypsinogen concentrations <10 ng/ml were used to identify CF-PI patients.

DNA Markers

Seven RFLPs have been detected in the 150 kb of DNA spanning the *D7S340/D7S122* loci (J. M. Rommens, M. C. Iannuzzi, B. Kerem, G. Melmer, M. L. Drumm, D. Kennedy, N. Plavsic, D. Markiewicz, R. Rozmahel, J. L. Cole, M. Buchwald, F. S. Collins, and L.-C. Tsui, unpublished data). The order and physical location of these markers, with respect to *MET* and *D7S8*, also have been established (Rommens et al. 1988b; J. M. Rommens, M. C. Iannuzzi, B. Kerem, G. Melmer, M. L. Drumm, D. Kennedy, N. Plavsic, D. Markiewicz, R. Rozmahel, J. L. Cole, M. Buchwald, F. S. Collins, and L.-C. Tsui, unpublished data) and are shown in figure 1. Because of the strong linkage disequilibrium observed among these RFLP loci, only three were chosen for the present study. E6 is a 6-kb *EcoRI* fragment cloned in plasmid vector pUC13. W3D1.4 is a 1.4-kb *HindIII* (or *HincII*) fragment isolated from an 11-kb *EcoRI* insert cloned in pUC13. JG2E1, cloned in the Bluescript™ vector (Stratagene), contains a 1-kb *EcoRI* insert that, on the basis of genetic and physical mapping data (J. M. Rommens, M. C. Iannuzzi, B. Kerem, G. Melmer, M. L. Drumm, D. Kennedy, N. Plavsic, D. Markiewicz, R. Rozmahel, J. L. Cole, M. Buchwald, F. S. Collins, and L.-C. Tsui, unpublished data), is apparently the same as the KM19 probe (*D7S23*) described by Estivill et al.

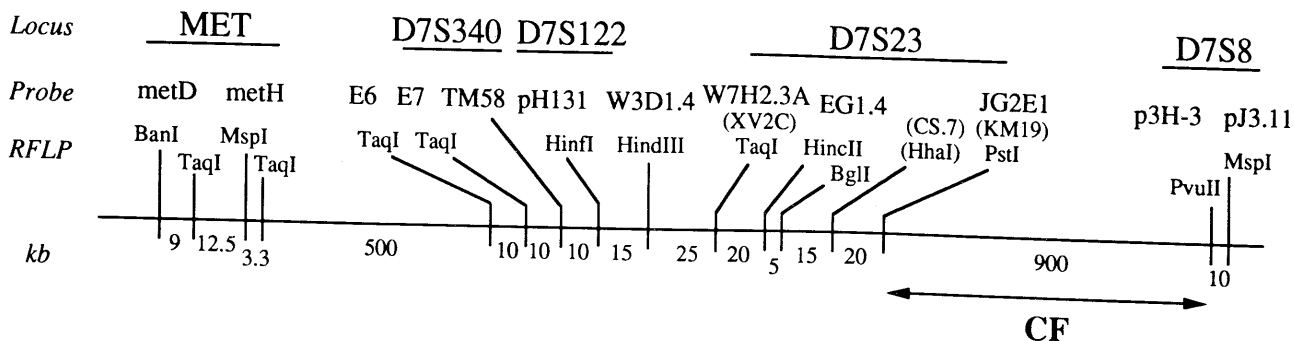

Figure 1 Physical localization of RFLPs spanning the D7S340/D7S122 loci.

(1987b). All three probes used in the present study were identified in our previous chromosome-walking and -jumping experiments (J. M. Rommens, M. C. Iannuzzi, B. Kerem, G. Melmer, M. L. Drumm, D. Kennedy, N. Plavsic, D. Markiewicz, R. Rozmahel, J. L. Cole, M. Buchwald, F. S. Collins, and L.-C. Tsui, unpublished data). The corresponding RFLPs are listed in table 1.

DNA Analysis

Total human genomic DNA samples were prepared from either Epstein-Barr virus-transformed lymphoblastoid cultures or peripheral blood samples, according to a method described elsewhere (Tsui et al. 1985, 1986b). Restriction-enzyme digestions were performed according to conditions recommended by the suppliers (New England Biolabs, Boehringer/Mannheim, and

Gibco/BRL). Agarose-gel electrophoresis and blot hybridization analysis were carried out essentially according to a method described elsewhere (Tsui et al. 1985).

Linkage Disequilibrium and Haplotype Analysis

The marker genotypes and haplotypes for normal (N) and CF chromosomes were derived from inspection of family data. Phase could not be determined for the RFLP alleles in five PI and three PS families, and thus their chromosomes were not included in the haplotype study. One other CF-PI chromosome was not included in the haplotype analysis because of incomplete DNA data. Pairwise, nonrandom allelic association value (Δ) was calculated according to the method of Chakravarti et al. (1984). χ^2 Statistics were used to assess the significance of association of phenotype with allelic and haplotype distributions.

Table 1

RFLPs and Allelic Distributions

PROBE NAME	RFLP ENZYME	FRAGMENT LENGTH (kb)		NO. OF CHROMOSOMES (frequency)						
				N ^a	CF ^a	[Δ] ^b	CF-PI ^c	[Δ] ^b	CF-PS ^c	[Δ] ^b
E6	TaqI	1	4.4	53 (.6)	72 (.80)	[-.22]*	58 (.8)	[-.21]*	35 (.84)	[-.22]*
		2	3.6	36 (.4)	18 (.20)		14 (.2)		7 (.16)	
W3D1.4	HindIII	1	20	63 (.83)	33 (.39)	[.41]**	27 (.39)	[.41]**	23 (.55)	[.25]*
		2	10	13 (.17)	51 (.61)		43 (.61)		19 (.45)	
JG2E1	PstI	1	7.8	58 (.67)	12 (.13)	[.55]**	8 (.11)	[.57]**	19 (.45)	[.21]†
		2	6.6	29 (.33)	78 (.87)		67 (.89)		23 (.55)	

^a The N and CF chromosomes are derived from the cohort of 46 CF families used for our regular CF linkage analysis (Tsui et al. 1986b); these numbers will be reported elsewhere (J. M. Rommens, M. C. Iannuzzi, B. Kerem, G. Melmer, M. L. Drumm, D. Kennedy, N. Plavsic, D. Markiewicz, R. Rozmahel, J. L. Cole, M. Buchwald, F. S. Collins, and L.-C. Tsui, unpublished data); they are included here for comparison.

^b The disequilibrium coefficient (Δ) is calculated according to the method of Chakravarti et al. (1984).

^c CF-PI is a subset of the cohort; CF-PS contains seven families from the cohort and 11 additional ones.

* $P < .01$ for continuity-adjusted χ^2 with 1 df.

** $P < .0001$ for continuity-adjusted χ^2 with 1 df.

† $.01 > P > .02$ for continuity-adjusted χ^2 with 1 df.

Results

In our original cohort of 46 families (Tsui et al. 1986b), seven of the families were classified as CF-PS and 39 as CF-PI. The diagnoses of the four Toronto CF-PS families (family 3, 14, 40, and 54) and 23 CF-PI families were based on the criteria described in Material and Methods. For the other families from clinics outside of Toronto, classification of pancreatic status was based on the information provided by the referring physicians; three families (families 27, 29, and 51) were classified as CF-PS and 16 as CF-PI. In all seven families classified as CF-PS, clinical phenotypes were concordant among patients within the same family. Fourteen additional CF-PS patients were ascertained through the Toronto clinic on the basis of the stringent criteria (13 fat balance studies and 12 pancreatic stimulation tests). None of these patients were receiving pancreatic enzyme supplements at age 7–38 years.

Since strong allelic associations were detected within three clusters of RFLPs in the D7S122/D7S340 region, haplotypes were constructed with the DNA probes E6, W3D1.4, and JG2E1, one selected from each linkage group (J. M. Rommens, M. C. Iannuzzi, B. Kerem, G. Melmer, M. L. Drumm, D. Kennedy, N. Plavsic, D. Markiewicz, R. Rozmahel, J. L. Cole, M. Buchwald, F. S. Collins, and L.-C. Tsui, unpublished data). The result of the haplotype analysis showed that the majority (51%) of CF chromosomes in our primary cohort of 46 CF families shared a common DNA marker haplotype (the A haplotype). In the seven CF-PS families, only two (14%) of the 14 CF-PS chromosomes carried the A haplotype. This striking underrepresentation of the A haplotype in the CF-PS patients was consistent with the hypothesis that they carry mutant alleles differ-

ent from those of the CF-PI patients. In order to substantiate this argument, 14 additional PS patient (and family) samples were collected to increase the CF-PS sample size, resulting in a total of 42 chromosomes in this group, versus 78 chromosomes in the CF-PI group.

As shown in table 1, the allele frequencies for the *TaqI*, *HindIII*, and *PstI* RFLPs, detected by the probes E6, W3D1.4, and JG2E1, among the CF-PI chromosomes are similar to those observed for our original cohort of 46 CF families that included both CF-PI and CF-PS (J. M. Rommens, M. C. Iannuzzi, B. Kerem, G. Melmer, M. L. Drumm, D. Kennedy, N. Plavsic, D. Markiewicz, R. Rozmahel, J. L. Cole, M. Buchwald, F. S. Collins, and L.-C. Tsui, unpublished data). This result is consistent with the fact that the majority of patients in that collection belong to the CF-PI category. The allelic distributions for W3D1.4 and JG2E1 among the CF-PS chromosomes are, however, markedly different from those for the CF-PI group. The degree of allelic association (linkage disequilibrium) increases for markers closer to the CF locus in the CF-PI group (see fig. 1). In CF-PS, although there is detectable allelic association between all 3 RFLP sites and CF, the Δ values remain rather constant over the entire region.

The haplotypes for the 14 additional CF-PS patients (families) were then analyzed. Only 22 chromosomes could be assigned unambiguously; the phase could not be determined in three cases because other family members were not available for the analysis. The combined data showed that four different haplotypes (A, B, E, and H) are almost equally abundant among the CF-PS chromosomes (table 2). This distribution is significantly different ($P < .0001$) from that of the CF-PI group, in which 60% of the CF-PI chromosomes have the same haplotype—the A haplotype. In addition, while the E

Table 2

Haplotype Association of DNA Markers with N, CF-PI, and CF-PS Chromosomes

	HAPLOTYPE			NO. OF CHROMOSOMES (frequency)		
	<i>TaqI</i>	<i>HindIII</i>	<i>PstI</i>	N	CF-PI	CF-PS
A	1	2	2	3 (.04)	39 (.59)	9 (.25)
B	1	1	2	12 (.17)	12 (.18)	7 (.19)
C	2	1	2	8 (.11)	9 (.14)	3 (.08)
D	2	2	2	1 (.01)	2 (.03)	0
E	1	1	1	25 (.35)	2 (.03)	8 (.24)
F	2	1	1	12 (.17)	1 (.02)	2 (.05)
G	2	2	1	6 (.08)	0	2 (.05)
H	1	2	1	4 (.06)	1 (.02)	5 (.14)
Total				71	66	36

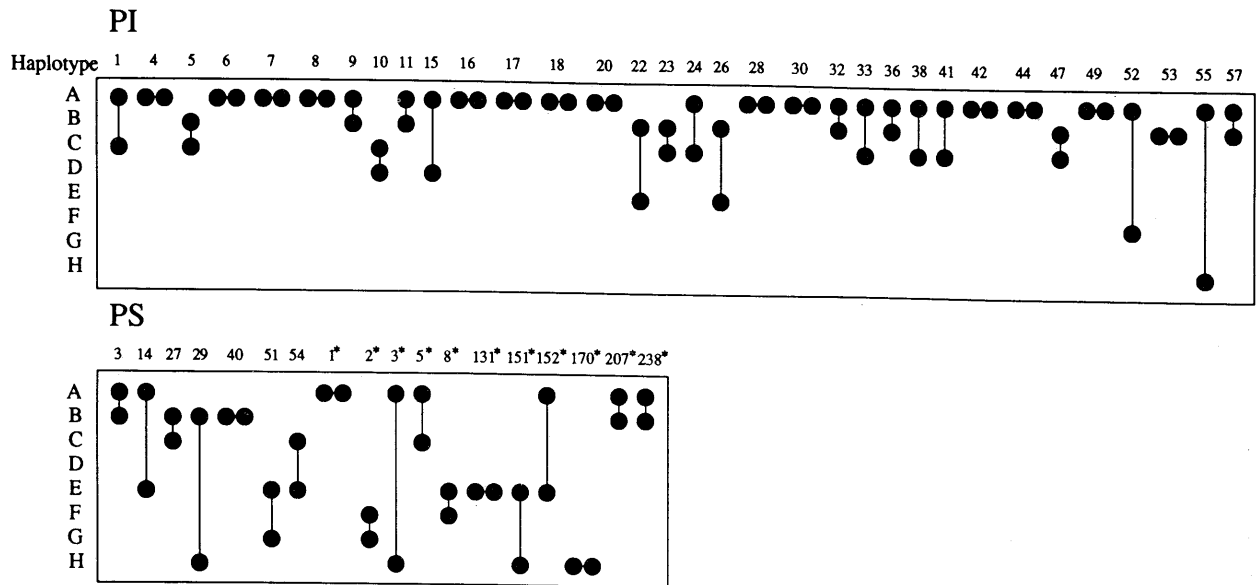

Figure 2 Haplotype analysis of individual CF patients (families) with PI or PS. The haplotype designations are the same as in table 2. The patient-identifying numbers (shown on top of each haplotype pair indicated by filled circles) correspond to the family numbers reported by Tsui et al. (1986b); those with an asterisk (*) are the additional CF-PS patients collected for the present study.

and H haplotypes are infrequent among the CF-PI chromosomes, they are two of the four common haplotypes among the CF-PS chromosomes. Further, there is no CF-PI with the G haplotype and no CF-PS with the D haplotype.

Additional information was obtained when the haplotypes were examined for individual CF patients (fig. 2). First, we found that only one of the 18 CF-PS patients was homozygous for the A haplotype, whereas AA was the most frequent (13/33) haplotype combination for CF-PI individuals ($P < .001$). This proportion of AA individuals with CF-PI was expected on the basis of the frequency (39/66) of the A haplotype among the CF-PI chromosomes. Second, the majority (14/18) of CF-PS individuals were found to be heterozygotes with respect to their haplotypes. The proportion of heterozygotes in CF-PS was, in fact, $>80\%$ (17/21), because three other CF-PS individuals, for whom haplotypes could not be assigned, were also heterozygous for two of the three DNA marker loci. This proportion of heterozygosity was consistent with random pairing of the different haplotypes in the CF-PS population. Among the CF-PI patients, only 63% (24/38) were heterozygotes. Last, in $>50\%$ (10/18) of the CF-PS individuals, at least one of their two CF chromosomes carried the E or H haplotype, whereas $<10\%$ (3/33) of the PI individuals carried these haplotypes ($P < .001$).

Discussion

The present study provides strong support for the hypothesis that the pancreatic function (PS vs. PI) in CF patients is genetically determined (Corey et al., in press). The striking difference observed between the DNA marker haplotype distribution of CF chromosomes in the CF-PS group and that in the CF-PI group further suggests that the two clinical phenotypes are predisposed by different mutant alleles. A similar observation has been made by Devoto et al. (1988) on the basis of study of CF patients in Italy using the KM19 and XV2C probes. In addition, it is of interest to note that American black CF patients, who have milder lung disease and more gastrointestinal complications (Stern et al. 1976), have a haplotype distribution different from that of the Caucasian patients (Cutting et al. 1989). Unfortunately, since the markers used in the latter study are different from the ones used here, a direct comparison has not been possible. Nevertheless, these observations are consistent with the general assumption that different clinical symptoms in CF are determined by different mutant CF alleles.

Our haplotype analysis indicates that, in the Caucasian population, CF-PI is genetically more homogenous than CF-PS. Since the most frequent haplotype in our CF-PI population is the A haplotype, representing 60%

of the CF chromosomes in this group, it is probable that one of the original mutations giving the PI phenotype occurred on this chromosome background. The fact that the A haplotype is rare in the normal population explains the strong allelic association (linkage disequilibrium) observed between the flanking DNA markers and CF. The other haplotypes associated with the CF-PI chromosomes may have resulted from either recombination between haplotypes or independent mutational events.

On the other hand, the A haplotype represents only 25% of the CF chromosomes in the CF-PS group, and three other haplotypes (B, E, and H) are almost equally abundant. Since the present study is solely based on haplotype association, we cannot predict whether the A and B haplotypes in CF-PI associate with the same mutation(s) as those in CF-PS. For the same reason, it is not known whether (a) the same mutation has recurred in different haplotype backgrounds or (b) different haplotypes represent different mutations. If the latter is true, however, our data would suggest that there are multiple mutant alleles responsible for conferring CF-PS. These putative CF-PS mutant alleles may define an intermediate clinical phenotype characterized by some preservation of pancreatic function. Since the E and H haplotypes are relatively more frequent in CF-PS, it is possible that at least two independent mutational events have occurred on each of these chromosome backgrounds. The G haplotype in CF-PS may harbor yet another mutation, although the number of representative cases is small. Consequently, there may be more compound mutant heterozygotes in CF-PS than in CF-PI. However, the present data do not allow us to exclude the possibility that the CF-PI and CF-PS phenotypes are also influenced by other genetic loci.

While final interpretation of the CF haplotype data awaits the molecular definitions of the actual mutations, the information on haplotype association may be useful in genetic counseling and disease prognosis. For example, on the basis of our current data, we predict that an individual homozygous for the most frequent CF haplotype (AA) would have a high probability (.39) of being a CF carrier and that ones with the EE or FF haplotype combination would have only a 1/142 or 1/333 chance, respectively. These numbers are similar to those based on a different set of DNA markers and different populations of CF patients (Estivill et al. 1987b; Beaudet et al. 1989). Most important, our data also predict that a CF patient homozygous for the A haplotype would almost certainly (>95%) have PI and that an EE patient would most likely (>85%) have PS. However, it should be cautioned that these risk calcu-

lations were based on haplotype association in a small number of samples. A more extended analysis including additional patients would be required to derive more-accurate risk estimates. Studies are also underway to investigate those CF patients who have late development of PI (Corey et al., in press) or other clinical symptoms such as meconium ileus and liver disease.

The gradual increase of linkage disequilibrium (Δ) values from E6 to JG2E1 (.22-.55) detected in the general CF population confirms that CF maps toward D7S8 from this cluster of DNA markers (J. M. Rommens, M. C. Iannuzzi, B. Kerem, G. Melmer, M. L. Drumm, D. Kennedy, N. Plavsic, D. Markiewicz, R. Rozmahel, J. L. Cole, M. Buchwald, F. S. Collins, and L.-C. Tsui, unpublished data). Since, as discussed above, CF-PI are genetically more homogeneous than CF-PS, it may be more appropriate, for future linkage disequilibrium calculations in CF gene mapping, to use the refined Δ values based on only the CF-PI patient data. In fact, for markers approaching the CF gene, there is no increase in the Δ values in CF-PS, consistent with allelic heterogeneity among this group of chromosomes. Moreover, since different CF mutations are probably associated with different haplotype backgrounds, our prior knowledge about the haplotype association in CF should facilitate rapid identification of these different CF alleles. Obviously, once these different CF alleles are identified, a direct correlation between the different clinical phenotypes and the nature of the mutations will be possible.

Acknowledgments

The authors wish to thank Dr. Gervais Aubin, Simone Aubin, Sue Carpenter, Louise Greene, Marlene Hall, Ann Reichert, Patricia Summers, Diane Thompson, and Dr. Damodar Vaze for patient coordination; Drs. Eitan Kerem, Georg Melmer, and Jack Riordan for helpful discussions; Martha Zsiga, Dara Kennedy, Danuta Markiewicz, Natasa Plavsic, and Richard Rozmahel for DNA analysis; and Shirley Sauvé for preparing the manuscript. This research is part of the Cystic Fibrosis Research Development Program at the Hospital for Sick Children and is supported by grants from the Canadian Cystic Fibrosis Foundation (CCFF), the Cystic Fibrosis Foundation (USA), the National Institutes of Health (USA), the North Dakota Cystic Fibrosis Association, and the Sellers Fund. L.-C.T. is a CCFF Research Scholar; J.M.R. is recipient of a Postdoctoral Fellowship from the Medical Research Council of Canada.

References

- Beaudet, A., A. Bowcock, M. Buchwald, L. Cavalli-Sforza, M. Farrall, M.-C. King, K. Klinger, J.-M. Lalouel, G.

- Lathrop, S. Naylor, J. Ott, L.-C. Tsui, B. Wainwright, P. Watkins, R. White, and R. Williamson. 1986. Linkage of cystic fibrosis to two tightly linked DNA markers: joint report from a collaborative study. *Am. J. Hum. Genet.* 39:681-693.
- Beaudet, A. L., G. L. Feldman, S. D. Fernbach, G. J. Buffone, and W. E. O'Brien. 1989. Linkage disequilibrium, cystic fibrosis, and genetic counseling. *Am. J. Hum. Genet.* 44:319-326.
- Berger, W., J. Hein, J. Gedschold, I. Bauer, A. Speer, M. Farrall, R. Williamson and C. Coutelle. 1987. Crossovers in two German cystic fibrosis families determine probe order for MET, 7C22 and XV-2c/CS.7. *Hum. Genet.* 77:197-199.
- Buchanan, J. A., B. Kerem, M. L. Corey, M. Buchwald, and L.-C. Tsui. 1988. Marker haplotype association with pancreatic sufficiency in cystic fibrosis. *Am. J. Hum. Genet.* 43:A79.
- Chakravarti, A., K. H. Buetow, S. E. Antonarakis, P. G. Waber, C. D. Boehm, and H. H. Kazazian. 1984. Nonuniform recombination within the human β -globin gene cluster. *Am. J. Hum. Genet.* 36:1239-1258.
- Corey, M., P. Durie, D. Moore, G. Forstner, and H. Levison. Familial concordance of pancreatic function in cystic fibrosis. *J. Pediatr.* (accepted).
- Cutting, G. R., S. E. Antonarakis, K. H. Buetow, L. M. Kasch, B. J. Rosenstein, and H. H. Kazazian, Jr. 1989. Analysis of DNA polymorphism haplotypes linked to the cystic fibrosis locus in North American black and Caucasian families supports the existence of multiple mutations of the cystic fibrosis gene. *Am. J. Hum. Genet.* 44:307-318.
- Devoto, M., M. Antonelli, F. Bellini, G. Borgo, O. Castiglione, L. Curcio, B. Dallapiccola, M. Ferrari, P. Gasparini, A. Giunta, L. Marianelli, G. Mastella, G. Novelli, P. F. Pignatti, L. Romano, G. Romeo, and M. Seia. 1988. Rarer alleles of DNA RFLP's closely linked to the CF gene are significantly more frequent in Italian CF patients without pancreatic insufficiency. *Am. J. Hum. Genet.* 43:A82.
- Drumm, M. L., C. L. Smith, M. Dean, J. L. Cole, M. C. Iannuzzi, and F. S. Collins. 1988. Physical mapping of the cystic fibrosis region by pulsed-field gel electrophoresis. *Genomics* 2:346-354.
- Durie, P. R., G. G. Forstner, K. J. Gaskin, D. J. Moore, G. J. Cleghorn, S. S. Wong, and M. L. Corey. 1986. Age-related alterations of immunoreactive pancreatic cation trypsinogen in sera from cystic fibrosis patients with and without pancreatic insufficiency. *Pediatr. Res.* 20:209-213.
- Estivill, X., M. Farrall, P. J. Scambler, G. M. Bell, K. M. F. Hawley, N. J. Lench, G. P. Bates, H. C. Kruyer, P. A. Frederick, P. Stanier, E. K. Watson, R. Williamson, and B. J. Wainwright. 1987a. A candidate for the cystic fibrosis locus isolated by selection for methylation-free islands. *Nature* 326:840-845.
- Estivill, X., P. J. Scambler, B. J. Wainwright, K. Hawley, P. Frederick, M. Schwartz, M. Baiget, J. Kere, R. Williamson, and M. Farrall. 1987b. Patterns of polymorphism and linkage disequilibrium for cystic fibrosis. *Genomics* 1:257-263.
- Farrall, M., B. J. Wainwright, G. L. Feldman, A. Beaudet, Z. Sretenovic, D. Halley, M. Simon, L., Dickerman, M. Devoto, G. Romeo, J.-C. Kaplan, A. Kitzis, and R. Williamson. 1988. Recombinations between IRP and cystic fibrosis. *Am. J. Hum. Genet.* 43:471-475.
- Gaskin, K., D. Gurwitz, P. Durie, M. Corey, H. Levison, and G. Forstner. 1982. Improved respiratory prognosis in patients with cystic fibrosis with normal fat absorption. *J. Pediatr.* 100:857-862.
- Gaskin, K. J., P. R. Durie, L. Lee, R. Hill, and G. G. Forstner. 1984. Colipase and lipase secretion in childhood-onset pancreatic insufficiency. *Gastroenterology* 86:1-7.
- Lathrop, G. M., M. Farrall, P. O'Connell, B. Wainwright, M. Leppert, Y. Nakamura, N. Lench, H. Kruyer, M. Dean, M. Park, G. Vande Woude, J.-M. Lalouel, R. Williamson, and R. White. 1988. Refined linkage map of chromosome 7 in the region of the cystic fibrosis gene. *Am. J. Hum. Genet.* 42:38-44.
- Orkin, S. H. 1986. Reverse genetics and human disease (review). *Cell* 47:845-850.
- Poustka, A., H. Lehrach, R. Williamson, and G. Bates. 1988. A long-range restriction map encompassing the cystic fibrosis locus and its closely linked genetic markers. *Genomics* 2:337-345.
- Rommens, J. M., S. Zengerling, J. Burns, G. Melmer, B. Kerem, N. Plavsic, M. Zsiga, D. Kennedy, D. Markiewicz, R. Rozmahel, J. R. Riordan, M. Buchwald, and L.-C. Tsui. 1988a. Identification and regional localization of DNA markers on chromosome 7 for the cloning of the cystic fibrosis gene. *Am. J. Hum. Genet.* 43:645-663.
- Rommens, J. M., S. Zengerling, M. Dean, M. C. Iannuzzi, F. S. Collins, G. Melmer, B. Kerem, M. Buchwald, and L.-C. Tsui. 1988b. Long-range restriction mapping of DNA markers closely linked to the cystic fibrosis locus by pulsed field gel electrophoresis. (Submitted).
- Spence, M. A., and L.-C. Tsui. 1988. Report of the Committee on the Genetic Constitution of Chromosomes 7, 8 and 9 (HGM9). *Cytogenet. Cell Genet.* 46:170-187.
- Stern, R. C., C. F. Doershuck, T. F. Boat, A. S. Tucker, F. P. Primiano, Jr., and L. W. Mathews. 1976. Course of cystic fibrosis in Black patients. *J. Pediatr.* 89:412-417.
- Talamo, R. C., B. J. Rosenstein, and R. W. Berninger. 1983. Cystic fibrosis. Pp. 1889-1917 in J. B. Stanbury, J. B. Wyngaarden, D. S. Frederickson, J. L. Goldstein, and M. S. Brown, eds. *The metabolic basis of inherited disease*, 5th ed. McGraw-Hill, New York.
- Tsui, L.-C., and M. Buchwald. 1988. No evidence for genetic heterogeneity in cystic fibrosis. *Am. J. Hum. Genet.* 42:184.
- Tsui, L.-C., M. Buchwald, D. Barker, J. C. Braman, R. G. Knowlton, J. Schumm, H. Eiberg, J. Mohr, D. Kennedy, N. Plavsic, M. Zsiga, D. Markiewicz, G. Akots, V. Brown, C. Helms, T. Gravius, C. Parker, K. Rediker, and H. Donis-Keller. 1985. Cystic fibrosis locus defined by a genetically linked polymorphic DNA marker. *Science* 230:1054-1057.

- Tsui, L.-C., K. Buetow, and M. Buchwald. 1986*a*. Genetic analysis of cystic fibrosis using linked DNA markers. *Am. J. Hum. Genet.* **39**:720-728.
- Tsui, L.-C., S. Zengerling, H. F. Willard, and M. Buchwald. 1986*b*. Mapping of the cystic fibrosis locus on chromosome 7. *Cold Spring Harbor Symp. Quant. Biol.* **51**: 325-335.
- van de Kamer, J. H., H. ten Bokkel Huinink, and H. A. Weyers. 1949. Rapid method for the determination of fat in feces. *J. Biol. Chem.* **177**:347-351.
- Wainwright, B. J., P. J. Scambler, J. Schmidtke, E. A. Watson, H.-Y. Law, M. Farrall, H. J. Cooke, H. Eiberg, and R. Williamson. 1985. Localization of cystic fibrosis locus to human chromosome 7cen-q22. *Nature* **318**:384-385.
- White, R., S. Woodward, M. Leppert, P. O'Connell, Y. Nakamura, M. Hoff, J. Herbst, J.-M. Lalouel, M. Dean, and G. Vande Woude. 1985. A closely linked genetic marker for cystic fibrosis. *Nature* **318**:382-384.