



Universidade de São Paulo

Biblioteca Digital da Produção Intelectual - BDPI

Departamento de Engenharia Aeronáutica - EESC/SAA

Artigos e Materiais de Revistas Científicas - EESC/SAA

2012

What is Missing for Traditional Design-Centric Engineering Education to Better Prepare Newly Graduated Engineers for the Global Era?

INTERNATIONAL JOURNAL OF ENGINEERING EDUCATION, DURRUS, BANTRY, v. 28, n. 4, p. 852-858, MAR, 2012

<http://www.producao.usp.br/handle/BDPI/37689>

Downloaded from: Biblioteca Digital da Produção Intelectual - BDPI, Universidade de São Paulo

What is Missing for Traditional Design-Centric Engineering Education to Better Prepare Newly Graduated Engineers for the Global Era?*

FERNANDO MARTINI CATALANO

Aeronautical Engineering Department, São Carlos Engineering School, University of São Paulo, Av. Trabalhador São-carlense, 400, Pq ArnoldSchimidt São Carlos—SP/Brasil, CEP 13566-590. E-mail: catalano@sc.usp.br

ÁLVARO MARTINS ABDALLA

Aeronautical Engineering Department, São Carlos Engineering School, University of São Paulo, Av. Trabalhador São-carlense, 400, Pq ArnoldSchimidt São Carlos—SP/Brasil, CEP 13566-590. E-mail: pfalvaro@sc.usp.br

FULVIO LUIZ DELICATO FILHO

Aeronautical Engineering Department, São Carlos Engineering School, University of São Paulo, Av. Trabalhador São-carlense, 400, Pq ArnoldSchimidt São Carlos—SP/Brasil, CEP 13566-590. E-mail: contatodelicato@bol.com.br

This paper presents an analysis of the capacity of design centric methodologies to prepare engineering students to succeed in the market. Gaps are brainstormed and analyzed with reference to their importance. Reasons that may lead the newly graduated engineers not to succeed right from the beginning of their professional lives have also been evaluated. A comparison among the two subjects above was prepared, reviewed and analyzed. The influence of multidisciplinary, multicultural and complex environmental influences created in the current global business era is taken into account. The industry requirements in terms of what they expect to 'receive' from their engineers are evaluated and compared to the remaining of the study above. An innovative approach to current engineering education that utilizes traditional design-centric methodologies is then proposed, aggregating new disciplines to supplement the traditional engineering education. The solution encompasses the inclusion of disciplines from Human Sciences and Emotional Intelligence fields willing to better prepare the engineer of tomorrow to work in a multidisciplinary, globalized, complex and team working environment. A pilot implementation of such an approach is reviewed and conclusions are drawn from this educational project.

Keywords: team working in engineering; human relations; leadership; aerospace design-centric

1. Introduction

The industry Human Resources (HR) department approach during the candidate's selection process has changed from matching the candidates' curriculum and the position technical requirements to a more holistic view of the candidate's capabilities in recent years. This holistic view includes capabilities currently far beyond those given by current engineering course disciplines. Existing engineering education strategies focus largely on delivering fundamental engineering principles of important core subjects. These subjects are subsequently leveraged on new products design and advanced technological solutions development. With the swift advancement of new technologies, the global increase and accelerated time-based competitions, the high population density and the demand for complex solutions, such traditional engineering education approaches have become questionable. The capacity to produce engineers with a strong aptitude after a problem and to work in such a globalised and multidisciplinary project environment should be reviewed to better cope with the

industry market demand. It was not uncommon to hear from the graduated Aeronautical engineers from Engineering School of São Carlos, University of São Paulo (EESC/USP), during the annual alumni meetings, that the university should include disciplines to provide such capabilities to engineering course students in order to fulfill the industry demand [2].

Most University educational programs in aerospace engineering were designed based on the following three important observations [3]:

1. The Aeronautical Engineering is a dynamic profession: 'The knowledge today may be inadequate for practice tomorrow.' So the Aeronautical Engineer must necessarily learn to learn.
2. Practical applications of engineering in Aeronautics Industry remain an art. Universities should teach the fundamentals and specific disciplines, but to gain the insight needed for the graduate to become a professional active in the aviation field, it takes three to seven years working in the industry.

3. Due to the fact that the main focus of the profession is in aeronautical vehicles, the student must learn almost all aspects of vehicle engineering. Initially, therefore, the educational program should be broader than specific.

The Aerospace industries broad focus on vehicles result in a required qualification for new entrants equally broad. This qualification should range from work in airports, certification, maintenance, air traffic control to all facets of aircraft design, testing, manufacturing as well as research and development. The first important goal of the educational program in aeronautical engineering should be to prepare the graduate to face successfully the tasks in the first year of work in the industry.

This educational program should provide to the egress a conceptual training and intellectual tools that will allow them to formulate a problem properly. It should also provide the egress confidence and sense of responsibility to solve problems quickly and accurately.

The aim of the engineer is, therefore, define and solve problems that will collaborate to design and manufacture products that will improve people's lives. To achieve this goal will require not only solid technical understanding but also the ability to solve problems, communication skills, team work and highly ethical behavior [4]. The ability in solving problems should be developed or taught to all students. An aeronautical engineering course should ensure that after five years of study (this is the case of Brazilian system), all graduate students have this ability. During graduation, students will find two types of problems: the closed and open solution form. The closed solution type has only one answer, and students feel comfortable with this type of problem and can solve them without much difficulty because they are provided with all information necessary for the solution. The purpose of this problem is to measure student understanding on a topic of engineering. This type of problem is also easy to be assessed by the teacher. However, problems of the closed form are rare in the aerospace industry [3]. On the other hand, the problems with open solution do not have a single right solution. Information available is not sufficient to solve the problem, which should be generated by the student. Because of this unique situation the student will be emotionally involved in solving the problem. This type of problem is used to measure the student's ability to bring together engineering theories with real-world problems such as designing a product. In other words, you can measure a student's ability to become an engineer. The student should be aware that although no single answer to the problem will be better solutions than others. They

should then decide on the merits of each solution, for example: the answer should emphasize safety, low cost, performance, style, durability, easy maintenance, or various other factors? This is basically the design process, and particularly the process of designing a new aircraft where teams work together aiming at the best solutions.

The airline industry is always in the face with these issues and wishes that the egress of Aeronautical engineering course is duly qualified to compose project teams for new products. It will also be essential that the graduate has received training in non-technical subjects, which will give him/her a concern about the universe in which the profession is practiced such as environmental and social impact, ethics, and philosophy.

This work presents a pilot program developed for the Aeronautical engineering course of EESC-USP already implemented as extra class activity in order to enhance the students '*emotional intelligence*'.

2. Presentation

A common theme in the annual alumni meetings of Engineering School of São Carlos, University of São Paulo—EESC/USP was the necessity to bring into the academy a broader vision of industry. Almost at the same time it was also a consensus that the quality of the professionals delivered by EESC/USP is one of the best. Although this high quality education, a question was brought into discussion: '*Why some of the graduated engineers from our university do not professionally succeed right from the beginning?*'. To answer this question we jointly developed an innovative idea, designed to further enhance the already excellent technical education that was given to the Aeronautical Engineering students. In line with the global demand for increasingly competent professionals far beyond the mere technical competence, a course project was designed with subjects thought to be important in the emotional preparation of the Aeronautical Engineering professionals. The objective of this course was to further increase its differentiation from competitors from other universities by enhancing the student emotional intelligence skills. The project (the *Pilot project*) was focused in developing several courses, grouped into a single module, which was named '*Personal Development for Engineers*'. These subjects aimed to introduce students to the branch of knowledge currently known worldwide and extremely appreciated by the industry as '*the emotional intelligence*'.

The project was carried out during 2009 second semester at the EESC/USP with students from last two years (4th and 5th years) of the Aeronautical Engineering course.

The objectives pursued by the disciplines were:

- Discuss the Future of Human Relations in the business environment;
- Identify the skills and competencies necessary for modern business executives;
- Study, understand and develop advanced leadership forms for High Performance Teams formation;
- To broaden students' level of consciousness, empowering them in the non-tangible professional side (*The Human Factor*).

To achieve these goals the following course topics were developed:

- Topic I—The Future of Human Relations
- Topic II—Values, Skills and Competencies
- Topic III—Assembling and Development of High Performance Teams
- Topic IV—Leadership
- Topic V—Consciousness Level Expansion
- Topic VI—Activities / Exercises

In Topic I—The Future of Human Relations—The consequences of the new paradigms brought into light by the increasingly competitive industry was discussed, as well as the industry globalization and the multidisciplinary work environment. Reference was also made to the change in the values caused by this new society behavior thus implying in a new power and leadership structure in society as well as in the industry project ambient. Finally what are the changing actions required for engineers of the future in light of such scenario was discussed.

In Topic II—Values, Skills and Competencies—The competencies required for the executives (future of the engineers . . .) was discussed to satisfactorily perform in the scenario described in topic I. Later the importance of understanding the process of selecting professionals using the method of 'profiling by competence' was studied. In sequence the process of planning the engineer professional maturity enhancement path increasing skills was analyzed and also was the competences to improve employability.

In Topic III—Assembling and Development of High Performance Teams—The reasons for the need of teams were discussed, as well as were the differences between (simply) a group of people and an actual team. An overview of the values and competences a team shall have it compared to the values and competences of an individual, as presented in topic II. Then the performance behavior graph of a typical team was discussed in detail (performance x effectiveness) presenting the several stages in the life of a team ranging from behaving simply as a group up to becoming an actual high performance team. Finally the basic conditions

required to move a group of people up to the stage of being considered as a team and the main steps to assemble and evaluate teams was discussed.

In Topic IV—Leadership—The essential qualities required for the engineer to perform as a leader were discussed. The old and the new industry management models was also presented comparing the behavior required by the engineer to perform well on the current (new) model. In the light of this new model the 'role theory' was discussed in detail in which the professional (the engineer) and the personal (the men/women) cannot be two different persons. In sequence the differences between a Manager and an actual Leader was highlighted, discussing the question of empowerment when it is acquired by merit or by delegation. At this point the concept of emotional intelligence was introduced, describing in detail the existing types of intelligences and those which shall be carefully cultivated for the professional success of the engineer. A brief review of the influences of the quality of human relationships in the engineer professional was discussed linking it to the ability of increasing the potential of the individual by proper motivation.

In Topic V—Consciousness Level Expansion—A method of concentrating one's actions on its own vision, relating it to the individual's desired path for success was presented. Before that, the concept of what is 'success' for the individual and for the team was discussed. The concept of self-knowledge and linking it to one's success path was also discussed. Then an analysis of the differences among people and its direct effect on human behavior was carried out. Finally, the main mechanisms of defense used by humans in specific situations (many times unconsciously), were presented.

In Topic VI—Activities / Exercises—A series of group activities (the 'dynamics') were presented and executed by the students which were previously divided in small teams. Also, individual activities and exercises were executed in order to demonstrate, among others, how to motivate cooperation between team members, how a leadership spontaneously can show up in a group and how the individual will feel/ behave under a non formal leadership and manners of detecting and working with such situations.

To deliver this curriculum a workload of 32 class-hours per course was planned. The classes were of the expositive type, with extensive inclusion of group and individual exercises and some group dynamics. A presentation of material on slides was used for the classes and exercises. Recommended reading and printed material was distributed for all students. An extensive list of references was also presented for those wishing to further develop the subject. Fig. 1 shows students at one of the dynamics



Fig. 1. Students in a dynamic activity.

activity. In this activity students should elect a leader and follow the leader's instructions to perform a simple activity. Under this scenario several characteristics of team working conditions, such as natural versus delegated leadership or as the confidence level in the leader by team members, were brought up and analyzed by the students after the exercise is finished.

2.1 The EESC/USP, Aeronautical engineering course

The educational project of the EESC-USP course in aeronautical engineering follows a set of activities based on requirements outlined below, in order to the graduate possesses the desired profile. These requirements are:

- Background of classical science and general education
- Learn to learn
- Teamwork
- Addressing open problems
- Multi disciplinarily
- Environmental and social information

The Aeronautical Engineering course at EESC-USP is a 5 year course divided in three phases: 1-basic, 2- general professional engineering and 3-specific engineering. Each phase has a main stream of disciplines although some preparatory/introductory disciplines in aeronautics are distributed through the first two years. There are three main directives for the all the disciplines: learn to learn, team work and addressing open problems. These directives, despite the fact that is not always ease to implement in every discipline taught, are essential for the multidisciplinary aspect of aeronautical engineering. In fact, the majority of disciplines are centered to develop student skills for aircraft design and to work at an aerospace engineering environment. However, engineering is not practiced in a vacuum nor the engineers live in a world made up of their own creations. Consequently, the educational

program in engineering also provides an appreciation of the world in which the graduate will act. This requires notions of cultural forces, political, ethical and aesthetic that affects the world.

There is an emphasis placed on design, and in particular Conceptual Design, in many aeronautical engineering courses [1]. A brief description of what is felt to be a typical approach is outlined as follows as a reference. At many universities, and this currently includes the case of the Aeronautical Department at the Engineering School of São Carlos, University of São Paulo—EESC/USP, Aircraft Design classes are undertaken in students groups. At the Aeronautical Department of EESC/USP the Aircraft Design course is split in two consecutive semesters during the graduation course 5th year. The first semester is dedicated to conceptual design and the second semester to preliminary aircraft design. Normally composed of 40 students, classes are divided into five groups of 8 students each. These groups are called 'project teams'. The work is undertaken in a dedicated classroom called 'aircraft design atelier', specially designed and assembled to simulate the actual industry design environment. The atelier is composed of five round tables, each one with two computer stations providing access to CFD, finite element and CAD packages. Fig. 2 shows a typical class at the atelier.

At the beginning of the first semester an aircraft specification is supplied to the design teams, providing details on the mission, range, speed, and take-off and landing performances etc. for the aircraft they should design. All specs are kept under the vision of actual certification requirements such as FAR 23 or 25. Table 1 shows an example of specification data that may be provided to the students at this point.

The students' groups work then through a process of conceptual design, using most of the acquired knowledge during the past 4 years of the engineering course they attended to. Although, at



Fig. 2. Students at the 'aircraft design atelier'.

Table 1. Typical data given to students

Range	5000 to 6000Km (full payload)
Passengers	130 to 160 PAX
Fuel Consumption	At least 25% lower than current aircraft

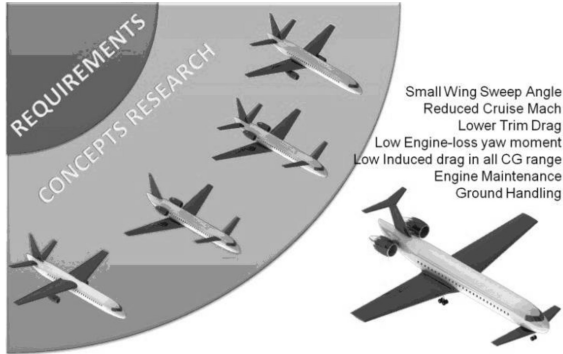

Fig. 3. Sample output configuration slide.

this stage (that is, the course’s 5th year) the students are free to develop their own design solution and proposals, as it is in the actual industry environment they must always keep their minds on requirements such as certification, market needs, environmental constraints etc.. This phase of work is very important because the students must deal with open problems in almost every part of their proposal. The concept of team work is now decisive for each team member to be emotionally involved in the proposal. After conceptual design is mature

enough, a final configuration is frozen by the project team to proceed to the next phase and all the conceptual process is presented to a board of reviewers. Fig. 3 shows an example of output slide provided by the students for the configuration selection.

During the next phase, that is, the preliminary design, undertaken on the second semester, advanced engineering tools are used by students for aerodynamic, structural, flight dynamics, control systems, etc. calculations. At this time in the course, the teams have already found out and/or defined their members’ competencies, and a group leader emerges not always without conflicts; this is an important element of their learning process. The final presentation is then prepared in the form of an integrated report which must include the results of both phases and also include a business plan for a hypothetical aircraft industry, addressing both, the technical aspects of the design and its financial viability. The ‘project’ is then presented at an examining board for evaluation. The board shall evaluate the technical results, the team organization, enthusiasm and the oral presentation quality. Fig. 4 shows an output example slide provided by the students for sizing at preliminary design phase.

As we can see the traditional engineering education strategies, including those curriculums using the design-centric engineering education, are largely based on the delivery of core and important subjects

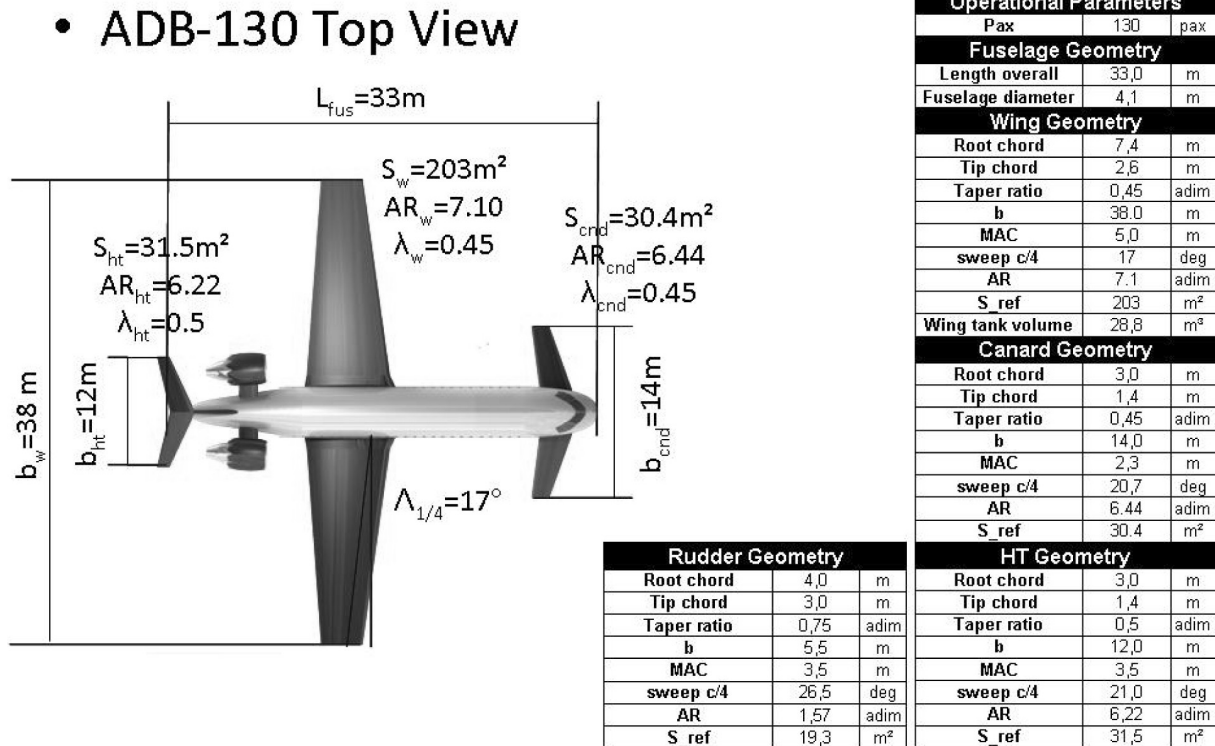

Fig. 4. Sample output preliminary design data slide.

of the so called ‘fundamental engineering principles’. Also common is the subsequent leverage of such subjects in designing new products and technological solutions. A design-centric education encompasses multiple disciplines and focuses project development driven by clear design objectives.

With new technologies swift advancement, increased in global and accelerated time-based competitions, high density population and complex solutions demand, such approaches should be enhanced to deliver engineers with adequate capacity for dealing with problems that are far beyond simply the design solutions around them. Such problems range from having different culture teams working at the same time on the same project, placed in different time-zones, with complementary expertise that needs to be coordinated to find a cost-effective solution for the project ‘problem’.

3. Results and discussion

3.1 Pilot project review method

Since this study was a subject matter related to the humanities, it was decided to use students’ evaluation methodology by ‘concepts’ instead of the traditional evaluation by ‘grades’. During the classes the performance and development was evaluated from each individual student through the review of the responses to the proposed exercises (all answered by the students and corrected in class) the participation and behavior of each student in the workshops, in the group exercises and in the dynamics.

A small part of the last class of the course was used for each student to express his own opinion on the question ‘*did we reach the goal set for this course?*’ [2].

3.2 Pilot project review results: academic (students) acceptance of the course subject

There was a high demand for the course by introducing a total of over 35 enrolled students of whom 33 were then confirmed at the beginning of the classes. Also very high, was the presence of confirmed applicants that reached levels above 95% in all classes. According to the evaluation made during the course’s last class, including students’ opinions, the course reached 100% of the proposed objectives defined at the beginning.

According to individual and group evaluations, a high return rate by the students was also achieved, where approximately 20% of them had an ‘excellent’ concept at the end of the classes and none of them had an insufficient performance.

With the classes progress it was noticeable great students’ development in the manner on how they faced the challenges, whether a current student life

challenge or a future professional challenge that life prepares for them after graduation. The insecure and fearful way that students presented before starting this classes led them to a much more structured and oriented way of thinking these challenges. After the end of the course, and closely following the professional lives of some selected students, it was clear that many of them (around 25%) immediately put into practice the techniques of planning and managing their own careers that the disciplines of this module (‘Personal Development for Engineers’) provided them with. Further interviews and messages from a number of students during and after the classes finished revealed the school’s assertion in answering to a need that has always existed in university-level students: further than providing the best in class technical engineering education (whether Design Centric or not) give the students a headquartered guidance and emotional preparation for professional careers so ‘assembling’ a complete engineer according to the modern industry requirements [2].

3.3 Pilot project review results: industry acceptance of course’s subject

Many were also the positive feedbacks received from the industry in general. From the very firm interest in the type of disciplines being offered to engineering students at the EESC/USP, demonstrated by entities with the importance of an Embraer (3rd biggest aircraft manufacturer in the world) or the EADS, up to professionals already graduated in the past years and currently well placed in the aircraft industry, wondering if this type of course could not be extended to them as a Continuing Education discipline.

4. Conclusions

The research results within the industry and the engineering students, made clear that the capacities the modern engineer needs to deal with and to succeed after currently existing ‘problems’ in the globalised era go far beyond the technical abilities given by the traditional engineering education strategies like the Design Centric Engineering Education. Design Centric engineering education is still a very good way to form a very good engineer. What is concluded in this paper is that further capabilities are required by the 21st century engineer to succeed in the industry other than those given by the traditional engineering education. These capabilities are, among others:

- Leadership
- Leadership of complex multidisciplinary experts teams

- Ability to cope with people to solve team relations problems (using emotional intelligence—The Human Factor)

After certain stage in the engineer career including the management levels achieved after a few years of experience using traditional engineering abilities, emotional intelligence or The Human Factor, will play a very important role in the professional success of engineers rather than only a good technical background. Also is concluded that in the current globalised working environment, this 'requirement' show up earlier in one's professional life than it used be in the past. This will require a change in engineering education already at the under-graduation level to comply with this industry requirement. It is an innovative learning pathway to educate engineers of tomorrow such that they are well-equipped to lead (that is trained and versed in the Human Factor) in solving complex and multi-disciplinary human relationship problems associated with the major challenges facing today globalized project environment.

Thus, approaches in engineering education programs need to be devised or aligned to provide students with extensive exposure to real-life, human relationship team-working issues and problems that they are going to face when exposed to a multicultural, globalized and complex project team environment.

Acknowledgments—The authors wish to thank Prof. Michael George Maunsell of his kind assistance in the preparation of this work.

Fernando Martini Catalano, Professor at the Engineering School of São Carlos, University of São Paulo—EESC/USP, Head of the Aeronautical Engineering Department, Mechanical Engineer School of São Carlos, University of São Paulo—EESC-USP in 1980, Master degree in Aerodynamics in 1988, PhD in Aerodynamics at Cranfield University College of Aeronautics in 1993. Academic Coordinator of the Aeronautical Engineering Course for the Engineering School of São Carlos, University of São Paulo—EESC-USP since 2001. AIAA Member, RAeS Member.

Álvaro Martins Abdalla, Assistant Professor at the Engineering School of São Carlos, University of São Paulo—EESC/USP, Master degree in Aerodynamics in 2004 by the Engineering School of São Carlos, University of São Paulo—EESC/USP, Doctorate Degree in 2009 by the Engineering School of São Carlos, University of São Paulo—EESC-USP, responsible for the 'Aircraft Design' and 'Research in Design Optimization' subjects in the Aeronautical Engineering Course for the Engineering School of São Carlos, University of São Paulo—EESC-USP.

Fulvio Luiz Delicato Filho, is a mechanical engineer with specialization in aeronautics by Engineering School of São Carlos, University of São Paulo—EESC/USP, class of 84. Granted post-specialization in Aircraft Turbine Performance Analysis by a combined course between CELMA/Brasil and University of Cranfield/UK, in 1993. Master degree in Business Administration with emphasis in Strategic Business Administration by a combined course among ESPM—Escola Superior de Propaganda e Marketing and ITA—Instituto Tecnológico de Aeronáutica in 2003. Worked for several of main Brazilian's airlines and for Embraer; Brazilian aircraft manufacturer. Also worked for Accenture, an international consulting firm where he was responsible for the 'Aviation, Aerospace & Defense' market in Latin America. Lecturer in 'Personal Development for Engineers' course at the Engineering School of São Carlos, University of São Paulo—EESC/USP in the Aeronautical Department. Currently owns an Engineering Consulting Firm that works mainly in the Airline, Aviation and Aerospace areas supporting several of the major airlines in Brazil and abroad.

References

1. T. M. Young, Aircraft design education at universities: benefits and difficulties, *Elsevier Science Ltd., Aircraft Design 3*, 2000, pp. 207–215.
2. F. L. Delicato, Relatório de Atividades—Curso 'Desenvolvimento Pessoal para Engenheiros', *Universidade de São Paulo—USP*, 2009.
3. J. H. McMasters, Influencing Engineering Education... One [Aerospace] Industry Perspective, 4th Harvey Mudd Design Workshop, July 10–12, 2003
4. N. Komerath and M. D. Maughmer, Educating the Aerospace Engineer of 2016 Proceedings of the 2005 American Society for Engineering Education Annual Conference & Exposition ASEE 2005, American Society for Engineering Education
5. T. Teal, The Human Side of Management, article in the *Harvard Business Review*, issue November–December, 1996, pp. 35–44.
6. S. J. Stowell and S. S. Mead, The Team Approach: with Teamwork Anything is possible, *Salt Lake City—UT—USA; CMOE Press*; 2007.
7. J. R. Katzenbach and D. K. Smith, High Performance Teams: concepts, principles and techniques to enhance team performance, Elsevier, 2001, 10th edition.
8. L. Grubbs-West, How to transform your team on your greatest asset, *Rio de Janeiro, Sextante*, 2007.
9. S. Jiusto and D. Dibiasio, Experiential Learning Environments: Do They Prepare Our Students to be Self-Directed, Life-Long Learners? *Journal of Engineering Education*, July 2006, pp. 195–204.
10. D. F. Radcliffe, Shaping the Discipline of Engineering Education, *Journal of Engineering Education* October 2006, p. 263.
11. P. Kumsaikaew, J. Jackman and V. J. Dark, Task Relevant Information in Engineering Problem Solving, *Journal of Engineering Education*, July 2006, pp. 227–239.
12. T. A. Litzinger, L. R. Lattuca, R. G. Hadgraft, Newsletter—Engineering Education and the Development of Expertise, *Journal of Engineering Education*, **100**(1), 2011, pp. 123–150.
13. S. Bhavani and M. Aldrige, Teamwork Across Disciplinary Borders: A Bridge Between College And The Work Place, *Journal of Engineering Education*, **89**(1), 2000, pp. 13–16.