

Brazilian Journal of Medical and Biological Research (2008) 41: 596-599
ISSN 0100-879X Short Communication

Expression of a hantavirus N protein and its efficacy as antigen in immune assays

L.T.M. Figueiredo¹, M.L. Moreli¹, A.A. Borges¹, G.G. Figueiredo¹, R.L.M. Souza¹
and V.H. Aquino²

¹Centro de Pesquisa em Virologia, Faculdade de Medicina de Ribeirão Preto, Universidade de São Paulo, Ribeirão Preto, SP, Brasil

²Departamento de Análises Clínicas, Toxicológicas e Bromatológicas, Faculdade de Ciências Farmacêuticas de Ribeirão Preto, Universidade de São Paulo, Ribeirão Preto, SP, Brasil

Correspondence to: L.T.M. Figueiredo, Centro de Pesquisa em Virologia, FMRP, USP, Av. Bandeirantes, 3900, 14040-900 Ribeirão Preto, SP, Brasil
E-mail: ltmfigue@fmrp.usp.br

Hantavirus cardiopulmonary syndrome (HCPS) has been recognized as an important public health problem. Five hantaviruses associated with HCPS are currently known in Brazil: Juquitiba, Araraquara, Laguna Negra-like, Castelo dos Sonhos, and Anajatuba viruses. The laboratory diagnosis of HCPS is routinely carried out by the detection of anti-hantavirus IgM and/or IgG antibodies. The present study describes the expression of the N protein of a hantavirus detected in the blood sample of an HCPS patient. The entire S segment of the virus was amplified and found to be 1858 nucleotides long, with an open reading frame of 1287 nucleotides that encodes a protein of 429 amino acids. The nucleotide sequence described here showed a high identity with the N protein gene of Araraquara virus. The entire N protein was expressed using the vector pET200D and the *Escherichia coli* BL21 strain. The expression of the recombinant protein was confirmed by the detection of a 52-kDa protein by Western blot using a pool of human sera obtained from HCPS patients, and by specific IgG detection in five serum samples of HCPS patients tested by ELISA. These results suggest that the recombinant N protein could be used as an antigen for the serological screening of hantavirus infection.

Key words: Diagnosis; Hantavirus infection; Araraquara hantavirus; N protein

Research supported by (FAPESP #03/03682-3) and the Virus Genetic Diversity Network Consortium of the State of São Paulo Research Council, Brazil (FAPESP #02/08459-8).

Received November 13, 2007. Accepted July 2, 2008

In 1993, a new hantavirus disease, hantavirus cardiopulmonary syndrome (HCPS), was described in the Americas associated with wild rodents of the subfamily Sigmodontinae (1).

The hantavirus genus of the Bunyaviridae family encompasses a large number of rodent-borne viruses that have a worldwide distribution. These viruses are transmitted mainly by inhalation of aerosols of infected rodent excreta. Hantaviruses are enveloped viruses with three single-stranded segments of negative-sense RNA genome, defined as small (S), medium (M), and large (L). The RNA segments are covered by the nucleocapsid (N) protein forming individual L, M and S nucleocapsids (2). The S

segment encodes the N protein, the M segment encodes a glycoprotein precursor that is processed into the enveloped G1 and G2 glycoproteins, and the L segment encodes the viral RNA polymerase. The N protein is synthesized early after infection and is the most abundant viral protein. The encapsidation of viral RNA by N protein subunits is recognized as a central event in the virus replication cycle (3). It is believed that N protein protects newly synthesized viral RNA from nuclease degradation. In addition, the N protein of the ribonucleoprotein core interacts directly with the cytoplasmic tail of the G1 protein of the virus to initiate virion assembly. It has been shown that N protein of some hantaviruses interacts with host cell pro-

teins such as the ubiquitin-like modifier-1 (SUMO-1) protein, the enhancer of apoptosis Daxx protein and the interferon-inducible MxA protein, blocking the antiviral effect of the infected cell (4-6).

The three structural proteins of hantaviruses (G1, G2, and N) can induce a high level of IgM, which is detectable at the onset of symptoms. The N protein induces a strong humoral immune response in humans and rodents; thus, it can be used as an antigen in immunoenzymatic assays for the diagnosis of hantavirus infection (1,2).

HCPS is an emerging disease in Brazil; from 1993 to 2007, 884 HCPS cases were reported with a 39% fatality rate (7). Currently, five hantaviruses associated with HCPS are known. Juquitiba virus was found in the Atlantic rainforest and in the Southern region and is associated with *Olygoryzomys nigripes*. Araraquara virus (ARAV) has been detected in the savanna (cerrado) region and the central plateau, having *Necromys lasiurus* as a reservoir. Laguna Negra-like virus occurs in the Chaco (Pantanal) mid-western region and has *Calomys* sp as a reservoir. Castelo dos Sonhos virus occurs in the Amazon region and has an unknown rodent reservoir. Anajatuba virus has been detected in the northeastern region, having *Olygoryzomys fornesii* as a reservoir. It is possible that HCPS cases reported in other parts of Brazil were caused by still unknown hantaviruses (8-11).

The diagnosis of HCPS cases has been mostly made by clinical presentation of the disease, epidemiological data and detection of anti-hantavirus IgM and/or IgG. IgM and IgG are detected by ELISA tests in few reference laboratories using as antigens N and G1 proteins of the Sin Nombre virus provided by the CDC (USA), and the Andes virus provided by the Instituto Carlos Malbrán, Argentina (1,12). In the present study, we describe the expression of the N protein of a Brazilian hantavirus. The S segment of the virus was amplified directly from the blood sample of an HCPS patient, a resident of the Ribeirão Preto region, São Paulo State. A previous study analyzing a fragment of 264 bp of the S segment showed that this virus has a high nucleotide and amino acid sequence homology with other 30 hantaviruses detected in HCPS patients in the same geographic region and all of them are closely related to ARAV (13).

Total RNA was purified from 300 μ L whole blood using Trizol LS reagent (Gibco, USA) according to manufacturer recommendations. The complete S segment of the hantavirus was amplified by RT-PCR using primers based on South American hantaviruses: Andes virus (AF291702), Maciel virus (AF482716), Pergamino virus (AF482717), Hu39694 (AF482711), Oran virus (AF482715), and Laguna Negra virus (AF005727). Overlapping fragments rep-

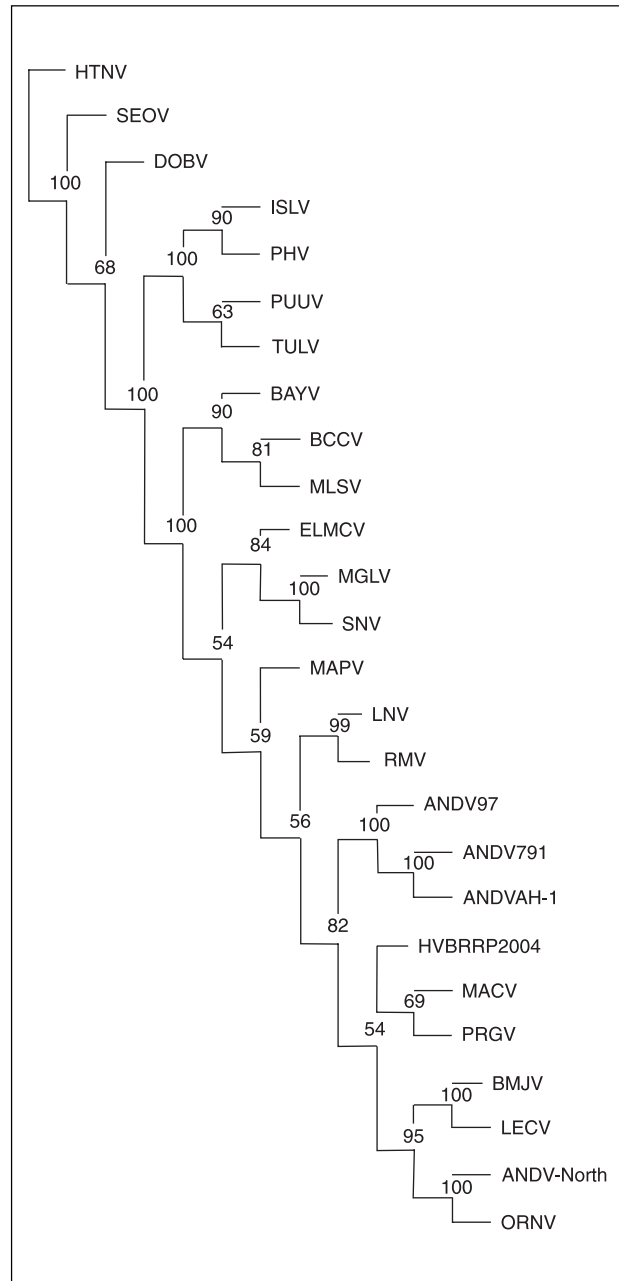

Figure 1. Maximum parsimony phylogenetic tree based on the complete nucleotide sequence of the hantavirus N gene including the HVBRRP2004 virus. The tree was constructed with the POY 3.1.1. software using Jackknife 1000 pseudo-replicates. GenBank accession numbers for the viruses included in the tree: HTNV - AF288659, SEOV - AF488708, PUUV - X61035, PHV - M34011, SNV - L25784, BAYV - L36929, LNV - AF005727, ANDV-North - AF291702, LECV - AF482714, MACV - AF482716, ORNV - AF482715, PRGV - AF482717, MAPV - AY267347, TULV - Z49915, BCCV - L39949, BMJV - AF482713, ANDV97 - AF291702, ANDV791 - AY228237, ANDVAH-1 - AF324902, DOBV - AJ410615. For ISLV, MLSV, ELMCV, MGLV and RMV, see Moreli et al. (13) and for ANDV-North, see Padula et al. (12).

representing the entire S segment were obtained using the following primers: EXTHAN5'-C, TAG TAG TAG ACT CCT TGA G; EXTHAN3'-S, TAG TAG TAT GCT CCT TG; SAHN-S, GAT GAA TCA TCC TTG AAC CTT AT; SAHN-C, CAA AAC CAG TTG ATC AAC AGG G; HANPL-C1, ATT AGT CCA GTC ATG GGG G; HANPL-S1 AAA GCA GGG AAT GAA ATT TAC; HANPL-C2, TGA GGA ATA CCA TCA TGG CAT; HANPL-S1, AAA GCA GGG AAT GAA ATT TAC; HANPL-C3, TAC ATG CTG TCC CTG GGG; HANPL-S4, TGG GGT AAA GAG GCT GTG. The contig sequence was constructed using the Vector NTI program (Invitrogen, USA). The complete S segment of this virus, denominated HVBRRP2004, was 1858-nt long and contained an open reading frame of 1287 nt, which encodes the N protein of 429 amino acids. The open reading frame is flanked by two untranslated regions, UTR5' of 42 nt and UTR3' of 529 nt. The putative amino acid sequence of the N protein gene was compared to the corresponding sequences of other viruses deposited in the GenBank. The highest identity for nucleotide sequence and for amino acid sequence was observed with the S segment of ARAV (data not shown). ARAV circulates in the Southeastern region of Brazil, having *Necromys lasiurus* as a rodent host reservoir (9). The complete N protein gene sequence of HVBRRP2004 virus was aligned with corresponding sequences of other hantaviruses deposited in the GenBank. Based on this alignment, a maximum parsimony phylogenetic tree was built using Jackknife 1000 pseudo-replicates (14,15). Phylogenetic analysis (Figure 1) showed that the HVBRRP2004

strain is closely related to Andes virus, especially to PRGV and MCV, both Argentinean hantaviruses (12).

A pair of primers was designed in order to amplify the entire N protein gene of the BRRP2004 strain: HANORF-C (CACC ATG AGC AAC CTC CAA GAA TTA CA) and HANORF-S (TCA CAG CTT TAA GGG TCC TTG GT). The complementary primer included the start codon (ATG) and four bases (underlined) that are recognized by the topoisomerase for direct cloning of the amplicon into the pET200D expression system (Invitrogen, USA). In this system, the recombinant protein is expressed with a 6xHistidine tag. The N protein gene was amplified by RT-PCR using the reverse transcriptase USB MMLV (Pharmacia, USA) and the Taq DNA polymerase (Pharmacia). The 1287-bp amplicon obtained was purified from agarose gel with the Qiaquick Gel Extraction kit (QIAGEN Inc., Germany) according to manufacturer instructions. The amplicon was introduced into the expression vector pET200D using the topoisomerase enzyme, and this reaction was used to transform *Escherichia coli* (BL21 strain). Plasmid-containing colonies were selected on an LB plate (50 µg/mL kanamycin). N protein expression was induced (1-4 h) in *E. coli* with 1 mM isopropyl β-D-thiogalacto-pyranoside (Gibco, USA). After expression, the cells were lysed and the proteins were subjected to 12% SDS-polyacrylamide gel electrophoresis. Figure 2 shows high expression of a protein of ~52 kDa, which corresponds to the N protein. Proteins were transferred from the polyacrylamide gel to a nitrocellulose membrane for Western blot analysis using a

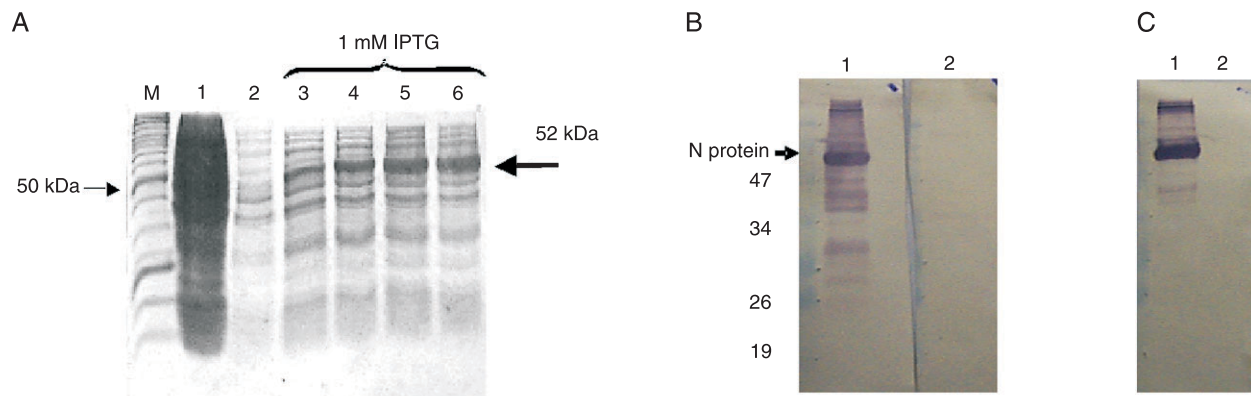

Figure 2. A, Silver-stained SDS-polyacrylamide gel of *Escherichia coli* lysates of a ~52-kDa band obtained from BL21 DE3 *E. coli*, that were induced with isopropyl β-D-thiogalacto-pyranoside (IPTG) for 1-4 h. M = molecular weight ladder; lane 1: extract of lysed *E. coli* transformed with a plasmid containing the N gene of Araraquara virus (ARAV) but without receiving IPTG induction, after a 16- to 18-h incubation period; lane 2: extract of lysed *E. coli* transformed with a plasmid containing the N gene of HVBRRP2004 but without receiving IPTG induction, after a 4-h incubation period; lanes 3-6: extract of lysed *E. coli* transformed with a plasmid containing the N gene of HVBRRP2004 and induced with IPTG over a period of 1, 2, 3, and 4 h. B, Immunoblot of lysed *E. coli* showing the specific detection of the N protein of HVBRRP2004; lane 1: test with sera from hantavirus cardiopulmonary syndrome patients showing a strong band at approximately 52 kDa; lane 2: test with serum of a cytomegalovirus infection case (negative control) showing no band. C, Lane 1: detection of the purified N protein of the HVBRRP2004 virus; lane 2: extract of lysed *E. coli* without plasmid.

pool of human sera obtained from HCPS patients. Figure 2 shows the specific detection of the 52-kDa protein by Western blot, confirming that it corresponds to the N protein. The N recombinant protein was purified under denaturing conditions (Figure 2) and then tested by ELISA against serum samples obtained from patients with (N = 5) and without (N = 8) HCPS. The IgG was positive for all five known positive samples and negative for all eight known negative samples. An extract of *E. coli* BL21 containing the vector pET200D without an insert was used as a negative antigen in the test.

Although recombinant N proteins of other hantaviruses such as Sin Nombre and Andes viruses have been produced as previously reported (16,17), they have not yet been reported with Brazilian hantaviruses.

A larger number of samples must be analyzed to confirm the usefulness of the N recombinant protein as an antigen in the ELISA test for the diagnosis of hantavirus infection. In addition, the antigenicity of this protein and its potential use as a vaccine will be studied by immunization of *Necromys lasiurus* rodents and analysis of the protection produced by this protein against hantavirus infection.

- Childs JE, Ksiazek TG, Spiropoulou CF, Krebs JW, Morzunov S, Maupin GO, et al. Serologic and genetic identification of *Peromyscus maniculatus* as the primary rodent reservoir for a new hantavirus in the southwestern United States. *J Infect Dis* 1994; 169: 1271-1280.
- Schmaljohn CS, Nichol ST. Bunyaviridae. In: Knipe DM, Howley PM (Editors), *Fields virology*. 5th edn. Philadelphia: Lippincott Williams & Wilkins; 2007. p 1741-1789.
- Khaiboullina SF, Morzunov SP, St Jeor SC. Hantaviruses: molecular biology, evolution and pathogenesis. *Curr Mol Med* 2005; 5: 773-790.
- Maeda A, Lee BH, Yoshimatsu K, Saijo M, Kurane I, Arikawa J, et al. The intracellular association of the nucleocapsid protein (NP) of hantaan virus (HTNV) with small ubiquitin-like modifier-1 (SUMO-1) conjugating enzyme 9 (Ubc9). *Virology* 2003; 305: 288-297.
- Li XD, Makela TP, Guo D, Soliymani R, Koistinen V, Vapalahti O, et al. Hantavirus nucleocapsid protein interacts with the Fas-mediated apoptosis enhancer Daxx. *J Gen Virol* 2002; 83: 759-766.
- Khaiboullina SF, Rizvanov AA, Deyde VM, St Jeor SC. Andes virus stimulates interferon-inducible MxA protein expression in endothelial cells. *J Med Virol* 2005; 75: 267-275.
- Coordenação de Controle de Vetores e Antropozoonoses SdVeSMdSB. Dados do Programa de Controle da Hantavirrose no Brasil de 1993 a 2004. www.saude.gov.br/svs.
- Johnson AM, de Souza LT, Ferreira IB, Pereira LE, Ksiazek TG, Rollin PE, et al. Genetic investigation of novel hantaviruses causing fatal HPS in Brazil. *J Med Virol* 1999; 59: 527-535.
- Suzuki A, Bisordi I, Levis S, Garcia J, Pereira LE, Souza RP, et al. Identifying rodent hantavirus reservoirs, Brazil. *Emerg Infect Dis* 2004; 10: 2127-2134.
- Figueiredo LT, Moreli ML, Campos GM, Sousa RL. Hantaviruses in São Paulo State, Brazil. *Emerg Infect Dis* 2003; 9: 891-892.
- Rosa ES, Mills JN, Padula PJ, Elkhoury MR, Ksiazek TG, Mendes WS, et al. Newly recognized hantaviruses associated with hantavirus pulmonary syndrome in northern Brazil: partial genetic characterization of viruses and serologic implication of likely reservoirs. *Vector Borne Zoonotic Dis* 2005; 5: 11-19.
- Padula PJ, Colavecchia SB, Martinez VP, Gonzalez Della V, Edelstein A, Miguel SD, et al. Genetic diversity, distribution, and serological features of hantavirus infection in five countries in South America. *J Clin Microbiol* 2000; 38: 3029-3035.
- Moreli ML, Sousa RL, Figueiredo LT. Detection of Brazilian hantavirus by reverse transcription polymerase chain reaction amplification of N gene in patients with hantavirus cardiopulmonary syndrome. *Mem Inst Oswaldo Cruz* 2004; 99: 633-638.
- Thompson JD, Gibson TJ, Plewniak F, Jeanmougin F, Higgins DG. The CLUSTAL_X windows interface: flexible strategies for multiple sequence alignment aided by quality analysis tools. *Nucleic Acids Res* 1997; 25: 4876-4882.
- Wheeler WC. Implied alignment: a synapomorphy-based multiple-sequence alignment method and its use in cladogram search. *Cladistics* 2003; 19: 261-268.
- Jonsson CB, Gallegos J, Ferro P, Severson W, Xu X, Schmaljohn CS. Purification and characterization of the Sin Nombre virus nucleocapsid protein expressed in *Escherichia coli*. *Protein Expr Purif* 2001; 23: 134-141. Erratum in: *Protein Expr Purif* 2002; 24: 171.
- Padula PJ, Rossi CM, la Valle MO, Martinez PV, Colavecchia SB, Edelstein A, et al. Development and evaluation of a solid-phase enzyme immunoassay based on Andes hantavirus recombinant nucleoprotein. *J Med Microbiol* 2000; 49: 149-155.