

Lincoln Cardoso Brandão

lincoln@ufsj.edu.br
Federal University of São João del Rei – UFSJ
São João del Rei, MG, Brazil

Reginaldo Teixeira Coelho

rtcoelho@sc.usp.br

Alexandre Tácito Malavolta

alexandr@sc.usp.br
University of São Paulo – USP
School of Engineering of São Carlos – EESC
São Carlos, SP, Brazil

Experimental and Theoretical Study on Workpiece Temperature when Tapping Hardened AISI H13 Using Different Cooling Systems

Tapping operations on hardened steels have always been a great challenge. Dry machining and two cooling systems were used when tapping hardened AISI H13 (53 HRC). Embedded thermocouples were used for temperature measurement close to the thread diameter in the radial and axial direction. A FEA model was used to evaluate the heat “Q”, and coefficient of convection “h”. The lowest temperature peak occurred with the flooded system, followed by the MQL, and dry condition. The heat and coefficient of convection increased when using the flooded system, followed by the MQL, compared to the dry condition. Those values were also in accordance with early published works, using different techniques.

Keywords: tapping, Minimum Quantity of Lubricant (MQL), Finite Element Analysis (FEA), steel AISI H13

Introduction

Since the beginning of the 20th century, when F. W. Taylor used water for the first time in metal cutting operations, a significant increase on tool life was experienced. Nowadays, a large variety of cutting fluids can be found for such purpose (Heisel et al., 1998). The use of fluids with lubricating properties, such as oil-based fluids, has also been another very common procedure aiming at longer tool life on selected machining processes, especially effective on low cutting speed. Oil-based fluids can lubricate better than water, since they drastically reduce the heat generation due to lowering friction at contact surfaces and contribute to produce a good surface finishing. Cutting forces are also reduced, leading to less power consumption for the whole cutting process. This has also been one of the main reasons to use cutting fluids with lubricating capacity (Belluco & De Chiffre, 2001).

New techniques for cooling and lubricating in cutting zone have been developed with aim of minimizing the friction and heat during machining process. The minimum quantity of lubricant technique, which is one of the effective methods to reduce the cutting oil consumption, has been widely applied to the cutting process. MQL technique uses a mixture of a small quantity of oil and compressed air supplied to the cutting point through a nozzle or by a channel through a spindle. MQL cutting can reduce not only the cost associated with the disposal of waste oils, but also the energy consumption related to the cutting fluid supply systems, while it may show some difficulties in cooling tool and work, carrying chips away from cutting zone (Belluco & De Chiffre, 2001). MQL is not always effective to any type of cutting. For example, MQL does not work so well in cutting difficult-to-machine materials with high strengths, low thermal conductivities and high affinities with tool (Heisel et al. 1998). There are few researches on MQL applied to heavy cutting with large depths of cut, feed rates, and high-speed cutting with high rates of heat generation (Obikawa et al., 2006).

Other cooling systems had been used as alternative to the traditional systems of cooling. Brandão et al. (2008) used frozen air as cooling system in the milling of hard steel used in molds and dies, maintaining the temperature of the workpiece near or below the environment temperature. The research works for the use of alternative cooling systems that come from meeting the current trends of non aggression to the environment have been carried out as

effective ecological system. Amongst all modern processes of machining, tapping is one of the most difficult operation in metalworking industry, since it is often performed at final stages, and a broken tap often causes a high scrap cost. Cutting fluids are often used in tapping process and are believed to be beneficial to the reduction of tapping forces, temperature, and to improve thread quality (Cao & Sutherland, 2002).

According to Cao & Sutherland (1998), MQL technique is a very attractive system for tapping, since it is essentially a low speed process and the lubrication properties of the oil can be effective. Aiming the better understanding of the cooling capacity of cutting fluids and MQL techniques, measurement of temperature in the tools or in the workpiece is used, allowing also the monitoring of temperature during cutting operations. The embedded thermocouple is a relatively easy and low cost technique to measure temperature. It can be used in large range of temperature and if adequately placed can be very efficient. Several authors as Leshock & Shin, (1997) and Aneiro et al. (2008) used the thermocouple technique with the objective of monitoring temperature in turning by inserting thermocouple in workpieces and tools, respectively. With the measured temperature, some theoretical models can evaluate the heat conducted to workpieces. Thus, while some heat is flowing into the workpiece, a significant part is being lost to the environment by convection effect.

To estimate the heat into the workpiece and also the coefficient of convection, two techniques can be considered. The first one depends on analytical mathematical models based on equations of heat, involving the solution of partial differential equations adapted, and simplified, to simulate practical operations. That usually leads to significant simplifications on the mathematical models, in general, due to complex workpiece geometries (Carslaw & Jaeger, 1986; Komanduri & Hou, 2000). The second technique uses Finite Element Analysis (FEA), which is based on some equations, but applied on simple small and finite elements. When those are put together, workpiece with complex geometries can be evaluated (Abukhshim et al., 2006).

According to Yvonne et al. (2005) the finite elements analysis in operation on aluminum alloy 6060-T5 with tools of HSS found maximum temperature values of 530 °C and value of 0.5 W/(m².C) for the convection coefficient. With the objective of simulating turning process Movahhedy et al. (2002) used PcBN tools with chamfered point. The tests had used tools with three angles of chamfer in the rake angle and three cutting speeds applied on AISI P20 steel. The results have shown that the technique of Finite

Element Analysis can be applied for optimizing cutting edge geometry, chip form, and cutting speed, regarding residual stress. Such technique, however, needs the heat and convection coefficient as input data. The values of the heat and coefficient convection had been inside of an acceptable range with great accuracy, when the finite element technique is employed (Özsisik, 1980; Incropera, 1990).

The aim of the experiments performed in the present work is to define the heat into workpiece close to the machined surface on tapping operation using two different fluid application systems. The results were compared to the same operation on dry condition. Additionally, a Finite Element Analysis for heat conduction was developed and used to evaluate the heat and convection coefficient. The Inverse Heat Conduction Method was used to fit the theoretical FEA model into the experimental data, by minimizing the errors with the Steepest Decent Method.

Experimental Work

The machining trials involved tapping process on AISI H13 workpiece (100 x 40 mm and 14 mm thick) with 53 HRC, and the following average chemical composition: 0.40% C, 0.95% Si, 0.31% Mn, 0.011% P, 0.006% S, 5% Cr, 0.12% Ni, 1.25% Mo and 0.13% Cu. Taps were single coated (TiAlN - TINAL FUTURA™) with 1.5 mm pitch, straight flute, overall length of 100 mm and thread length of 24 mm with reinforced shank according to DIN 371. A machining center ROMI model Discovery 560 with 7,500 rpm and 15 kW of spindle power was used. The cutting conditions were chosen according to recommendations from manufacturer and are shown in Tab. 1.

Table 1. Experimental conditions chosen for the tapping experiments.

Tool code	Hole diameter [mm]	Cutting speed [m/min]	RPM	Feed speed [mm/min]
B1278TCN*M10	8.6	3.0	95	143

Figure 1 shows the scheme of embedded thermocouples axially with 0.1 mm distance from the largest thread diameter, designated as Pos_1. Figure 2 shows a general view of the workpiece and its scheme radially for a maximum number of tapped holes. Avoiding the contact of the tool with the thermocouple and electrical signal lose this distance from the heart source was chosen. The same axial configuration was used for the distances of 2.5 and 5.0 mm, Pos_2 and Pos_3. By using this assembly, it was possible also to define the radial heat. Along the workpiece thickness, the thermocouples were positioned at 3.0, 7.0, and 11.0 mm from the tap entrance, designated as T0, T1 and T2, respectively. They were type “T” of Copper-Constantan with gauge AWG 30 (0.051 mm²) and temperature range among -18 to 205 °C with accuracy of 0.2 °C, and it was necessary to register temperature from 0.1 mm of the heat source. A thermostatic bath with ethileno-glicol was used to calibrate them within the range of 10 to 90 °C.

The thermocouples were inserted in 2.3 mm hole diameter. Tests were replicated twice for each experiment, with aim of analyzing only the temperature tendency. The thermocouple wires were short and connected to an electronic circuit, working as a signal conditioner, and then to a National Instruments model SCB 68, which connected to an acquisition board model PCI - MIO - 16E - 4 in a personal computer. The acquisition rate was 10 points per second for the temperature. Cutting fluid applied on both systems was BioG 850, mineral-based oil, viscosity 18 cSt at 40 °C, produced by Microquímica™. The MQL system was set for 20 ml/h, both with integral mineral oil. Dry tests used the same machining conditions. Figure 3 shows the set up used for the experiments. The dynamometer demonstrated in Fig. 3 was not used in this work.

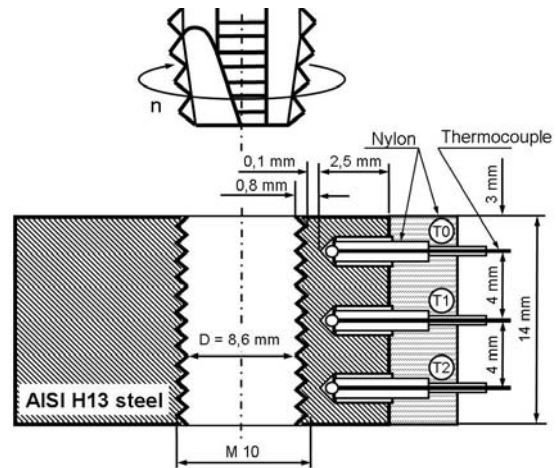

Figure 1. Lay-out of the embedded thermocouples (Example for the Pos_1 at 0.1 mm from the machined surface).

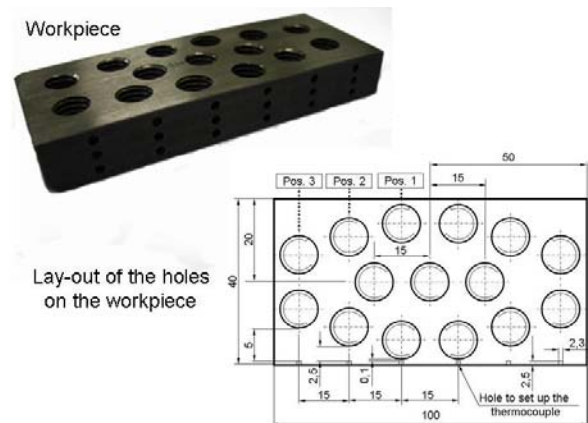

Figure 2. Lay-out of the holes on the workpiece.

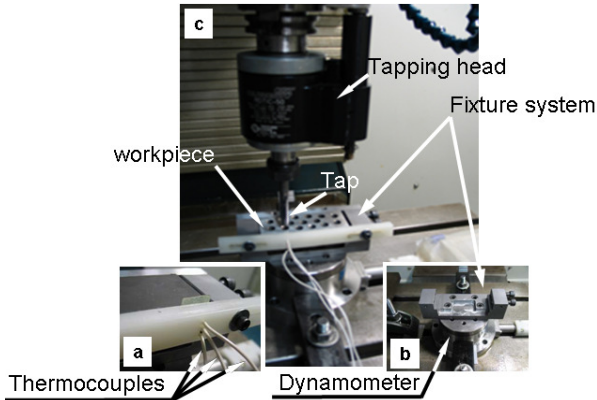

Figure 3. Lay-out of the experiment.

The holes were initially drilled with Alpha-Rc tool model A3269TFL Ø 8.6 and their diameter was kept within 8.6 ± 0.02 mm. Drilling conditions were 25 m/min of cutting speed and 0.03 mm/rev of feed rate.

Heat Conduction Model

ANSYS™ Software was used to define the workpiece mesh and simulates a theoretical model of heat flowing into the workpiece and being exchanged with the cooling fluids by convection. The workpiece was divided into 48 elements distributed radially, and 20 elements distributed along the length. Thus, the mesh of 960 elements provided the same number of load steps, allowing a better precision for adjustment and minimizing the error between experimental and simulation data. Figure 4 shows detail of the mesh.

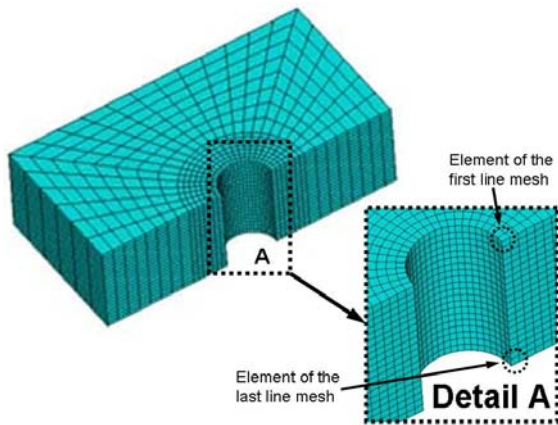

Figure 4. Mesh used to model the machined part of the workpiece.

The heat application started into the first element of the first line mesh until the 48th element. Afterwards, the heat was applied into the 49th element on the second line mesh below. This strategy of simulation was realized with the objective to represent the tap geometry approaching the ideal condition considering the feed rate of the tool in the tapping.

During the simulation, the first element on the internal surface receives heat “Q” in Joules (coming from the heat source, i.e. the chip formation) through surface 2 (Fig. 5), similarly to the experimental condition, when the tap enter in workpiece. All the other elements on the hole wall, upper and lower surface, exchange heat with the environment using “h”, which represents the

coefficient of convection in $W/(m^2 \cdot ^\circ C)$ (Fig. 5). After calculating the temperature distribution for the whole domain, the same procedure is applied to the next element, since the heat source (chip formation) moves to the next element. That procedure goes on following the tap path until the last element on the hole wall is reached. As the heat source moves, simulating the helical movement of the tap, only the elements ahead of it are subject to convection heat exchange. That was used since the tap fills the formed threads preventing that surface to exchange heat with the cooling fluid by convection. At the end, the final temperature distribution is obtained and the theoretical temperature-time curves are obtained for all elements, including those where the thermocouples were placed. Figure 5 illustrates the element with all the boundary conditions assumed.

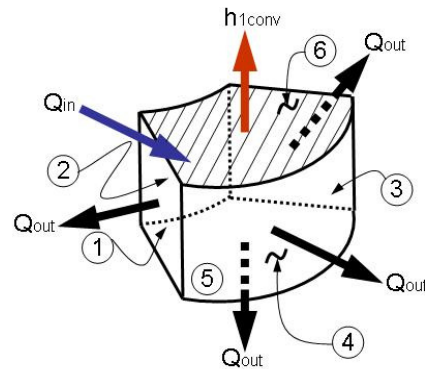

Figure 5. Detail of the load steps in the elements.

To obtain this first set of 3 curves, corresponding to each thermocouple position, it is necessary to guess an initial pair of “Q”, “h” and run the modeling. The initial values were calculated based on the 10% of the total cutting energy being transferred to the workpiece, according to:

$$\Delta Q = mc_p \Delta \theta \tag{1}$$

where m is the simulated element mass, c_p is specific heat at constant pressure and $\Delta \theta$ is the increase in workpiece temperature nearest the threads. Values of convection coefficient were previously established according to some references in the heat conduction area (Incropera & Dewitt, 1990; Özisik, 1980; Bejan, 1996). After running the FEA model the program supplies nine curves $\theta_{FEM}^{i,j}(t)$. The index i is the thermocouple position $i = 1 \dots 3$ for each distance from the maximum thread diameter, i.e., Pos_1, Pos_2 and Pos_3, at 0.1, 2.5 and 5.0 mm. The index j is the distance from the tap entrance, i.e., T0, T1 e T3, at 3.0, 7.0 and 11.0 mm. After obtaining those curves they had to be compared to the experimental ones $\theta_{EXP}^{i,j}(t)$, and the error calculated for each curve:

$$Er^{i,j} = \frac{\sum_{k=1}^N \left| \theta_{FEM}^{i,j}(t_k) - \theta_{EXP}^{i,j}(t_k) \right|}{N} \tag{2}$$

where N is the number of points acquired during the time. Up to this stage there is an average error for each curve, and an overall average error for each cooling system was calculated by:

$$Er_{avg} = \frac{\sum_{i=1}^9 er^i}{9} \tag{3}$$

In order to find the estimated values for “Q” and “h”, which minimize the average error function, Er_{avg} , the Steepest Decent Method was employed. It consists basically in estimating a first point P_i for the function and move to point P_{i+1} in the direction of the local downhill gradient $-\nabla Er_{avg}(P_i)$ (Flannery, Teukolsky & Vetterling, 1990). This method was adopted due to its simplicity and leads to a local minimum, which seemed good enough since the energy, for example, has its limit roughly between zero and the cutting power. The convection coefficient has also some known limits from 50 to 200,000 $W/(m^2 \cdot ^\circ C)$ (Incropera & Dewwit, 1990; Özisik, 1980; Bejan, 1996). To find the gradients, in both directions, (“Q” and “h”) steps were established and four new points were simulated around the first guessed one. Each error function was calculated and the steepest gradient followed until the error valley was found. At this point, the best combination of “Q” and “h” had been found for each experiment condition.

The step for the energy was selected as 50 J and for the convection coefficient depended on the cooling system. The whole minimum search procedure was implemented by using a program developed in MatLab™ software. The stop criterion was less than 0.1 for Er_{avg} , or 5 steps in any direction. The machined surface 2, in Fig. 5, received energy from the moving source (chip formation) only at the element where the tool was at a particular moment. Other element face 6 lost heat according to the cooling system being simulated; this case occurs only for the first domain. The surfaces 1, 3, 4, and 5 exchange energy with the other elements of workpiece mesh, which are not affected by cutting process.

Results and Discussions

Temperature Measurements

Figure 6 shows a typical experimental temperature graph when tapping AISI H13 in flooded conditions. The temperature was registered at distance of 0.1 mm, making it possible to observe that the other graphs for the MQL systems and dry tapping had a similar behavior, only with differences on the maximum temperature. The data acquisition began approximately 5 seconds before the tap reached the upper face of the workpiece, at ambient temperature of 24 °C. Although the tapping operation lasted about 12 seconds, temperature was recorded for 100 seconds, allowing a complete stabilization. It can be observed that maximum temperature at 3 mm from the workpiece surface is the lowest and increases as the tap goes deeper inside the hole. That can be explained because as the tap goes deeper, more heat is produced and accumulated like successive heat “waves” being created. The thermocouples positioned ahead of the tool will receive and register the “waves”, since feed speed is relatively low.

The peaks of temperature are different for each condition tested, being the biggest values of temperature peaks for the tapping in dry condition, and the least ones for the flooded condition. Table 2 shows a general result for temperature peaks in all cooling conditions. The MQL system registered values of peak of

temperature next to the values to the dry tests. This demonstrates that MQL systems do not present good conditions of cooling for tapping process in function of not reaching the cutting zone and effectively not decreasing the temperature. This occurred because the tap filled all the empty spaces, not allowing the performance of the cutting fluid. As the tap front cutting passes through the thermocouple position, the temperature tends to go lower, generally because heat is lost on the workpiece and threaded surfaces. After some time, all the workpiece medium tends to the same temperature value and, finally to ambient. The graphs for positions Pos_2 and Pos_3 with distances of 2.5 and 5.0 mm had the same behavior; however, the positions of thermocouples had presented lesser peaks of temperature for all cooling systems.

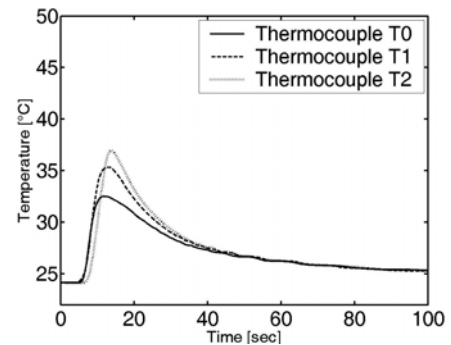

Figure 6. Temperature measured at 0.1 mm from machined surface with flooded system.

The curves obtained at T0 and T2 are subjected to two effects during the tapping operation. First, the heat is conducted through the steel and by convection on the plate surfaces, since they were at 3.0 mm from the upper surface (Fig. 1). Thus, the adjustment of the graphs was accomplished considering the medium values of the nearest position at 0.1 mm to more distant position, i.e. 5.0 mm for each condition of cooling, and Fig. 7 shows the adjusted graphs. Those adjusted graphs were used to compare with the theoretical FEA model used to find the values of heat and convection coefficient. The adjustment of the temperature curves was necessary initially for the tapping time tests and for simulation, since they were the same ones, and also the time of natural cooling was eliminated, not influencing the adjustment in the method of finite elements.

The adjusting of the graphs was the same procedure for all cooling conditions, maintaining the temperature peaks similar to the experimental tests. It can be observed that the graphs for the first thermocouple T0 have a longer peak of temperature due to increasing of heat that is received during all the tapping process. However, this situation for the thermocouples T1 and T2, with the temperature peaks occurring faster due to the time contact, is faster if not allowing the stabilization of the temperature.

Table 2. General results of temperatures peaks for all cooling conditions.

Cooling System	Temperature [°C] Pos_1 [0.1 mm]			Temperature [°C] Pos_2 [2.5 mm]			Temperature [°C] Pos_3 [5.0 mm]		
	T0	T1	T2	T0	T1	T2	T0	T1	T2
Dry	37.6	49.2	57.4	38.8	41.4	42.4	35.4	36.6	37.4
MQL	35.4	43.8	45.2	37.8	41.2	41.6	34.2	36.4	37.0
Flooded	34.0	35.8	36.6	33.0	35.8	36.2	32.6	35.2	36.8

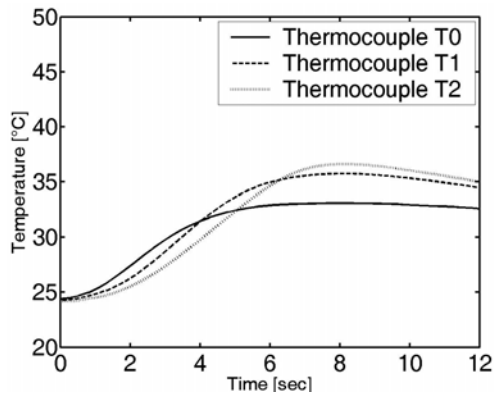

Figure 7. Temperature measured at 0.1 mm from tapping surface. Curve adjusted for 12 seconds.

Simulation of the Heat and Convection Coefficient

Figure 8 shows a typical graphic resulted from the ANSYS™ simulation. The differences were on the maximum temperature peak reached for each pair of input data. The original curve presents a great oscillation, since the heat source (chip formation) runs up and down on the curve workpiece surface, and also the elements had a finite mass and volume. In the FEA simulation, the oscillation was much more evident because thermocouple time response was not modeled. Therefore, the original graphs were smoothed using a moveable median function of LabView™ program with 50 points. Some simulations had been carried through (50 points were an ideal number) and it did not affect the behavior of the graphs nor its values. After the smoothing, the graphs obtained were confronted with the experimental one and submitted to the minimum error search, according to Eq. (3), using the Steepest Decent Method in a MatLab™ routine.

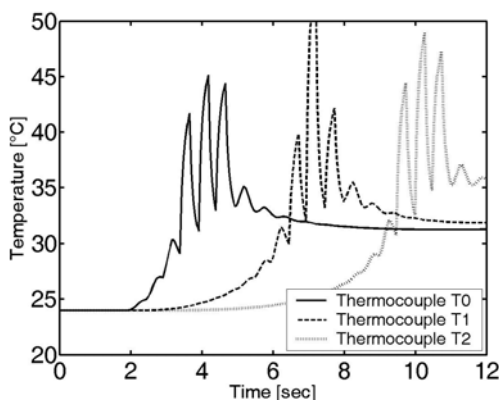

Figure 8. Typical curve of temperature obtained from FEA simulation.

Figure 9 shows the comparison between experimental and simulated data, after filtering. It can be observed that the curves present increasing peaks of temperature in similar ways as the experimental tests. The distance of peaks for simulating is symmetrical with the same spacing. It occurs due to the theoretical position of thermocouple in the mesh, which shows a regular behavior to receive energy and change heat with elements of its neighborhood. There are two reasons to explain this. First, this situation can be analyzed considering that the theoretical values do not have influences of external variable like the attrition and sudden variations that can occur in the cooling systems or like outflow and pressure. Second, it can be observed that the response time of the

thermocouples is not identical, being possible to occur small variations with the delay of the signal of register of the data.

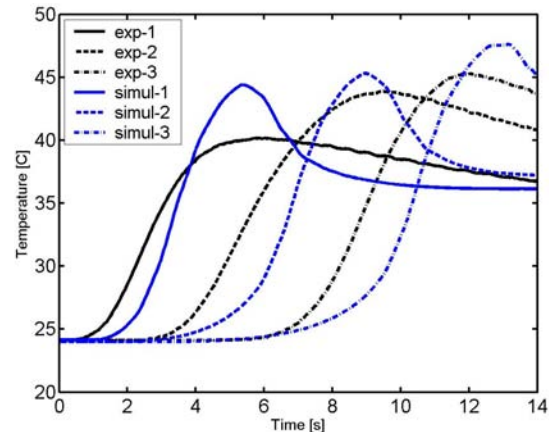

Figure 9. Comparison between experimental and simulating curves (Simulation curves were filtered).

Tables 3, 4 and 5 show the results of simulation for dry, MQL and flooded cooling systems. The values on the tables are average error, highlighting the minimum found, corresponding to the best values for heat and convection coefficient. The values of the heat in MQL and flooded system were the same 25 Joules, which occurred because the MQL system is considered a system close to the dry condition, thus its cooling capability is almost identical to the compressed air. The results demonstrate and confirm that MQL system has a good lubricant potential, as shown in other works of research (Brandão & Coelho, 2009).

Table 3. Summary of the average quadratic error, Eravq (dry condition).

Dry condition		Convection coefficient h [W/(m².°C)]			
		10	50	100	150
Energy "Q" [J]	5	26.6 %	26.6 %	26.6 %	NS*
	10	13.8 %	25.6 %	22.2 %	22.9 %
	15	15.6 %	17.8 %	17.8 %	17.8 %
	20	13.8 %	13.6 %	13.6 %	13.8 %
	25	NS*	11.5 %	11.4 %	11.4 %
	35	13.2 %	13.1 %	13.8 %	13.8 %
	40	13.8 %	NS*	16.2 %	NS*

NS = Condition not simulated

Table 4. Summary of the average quadratic error, Eravq (MQL condition).

MQL condition		Convection coefficient h [W/(m².°C)]				
		10	50	100	150	10000
Energy "Q" [J]	5	21.7 %	21.7 %	21.7 %	NS*	NS*
	10	8.9 %	20.6 %	17.3 %	17.3 %	NS*
	15	9.6 %	12.9 %	12.9 %	12.9 %	NS*
	20	8.7 %	8.5 %	8.4 %	8.6 %	8.6 %
	25	NS*	5.7 %	5.6 %	5.6 %	NS*
	35	NS*	7.1 %	7.8 %	7.8 %	NS*

NS = Condition not simulated

Table 5. Summary of the average quadratic error, Eravq (flooded condition).

Flooded condition		Convection coefficient h [W/(m ² .°C)]				
		10	50	100	150	10000
Energy "Q" [J]	5	NS*	NS*	NS*	NS*	NS*
	10	10.2 %	10.2 %	10.2 %	10.2 %	10.2 %
	15	7.8 %	7.8 %	7.8 %	7.8 %	7.8 %
	20	10.1 %	NS*	NS*	10.1 %	10.0 %
	25	13.4 %	NS*	NS*	NS*	NS*

NS = Condition not simulated

The error for dry condition is greater than the error for MQL system. This can be explained in function of the difficulty to define the coefficient of convection for air in normal ambient conditions. This situation does not occur with MQL, because the mist can act into the empty space between chip/workpiece, as the air is pressurized. Considering the results for flooded system, the heat has the lowest value. This was already expected, because the oil has a very large cooling capacity, mainly when applied abundantly.

The values for convection coefficient are in the range of reference bibliography. According to Incropera & Dewitt (1990), the values of the convection coefficient are from 50 to 200,000 for air, depending on the pressure, air temperature, speed, etc. Thus the values for convection coefficient in Tables 3, 4 and, 5 are according to the reference, showing an increase of the capacity of cooling with proportionality to the system used, as shown in Table 6.

Table 6. Estimated values for "Q" and "h" for all cooling systems.

Estimated Variables	Cooling systems		
	Dry	MQL	Flooded
Q [J]	25	25	15
H [W/(m ² .°C)]	100	100	10000

Conclusions

Based on the present results, the following conclusions can be reached:

- The difference found on the temperature peaks, when using different cooling systems, shows a small variation amongst all the measurements in either radial or axial positions on tapping;
- Peaks of thermocouples T0 and T2 were lower because of the heat dissipation through the upper and lower workpiece surfaces. Additionally, at the middle of thickness friction adds more heat;
- The simulation model developed with FEA shows to be able to reasonably approach experimental temperature curves, although a peak was only theoretically found;
- The FEA associated with the Steepest Decent Method, implemented in MatLab™, was capable of estimating the heat into the workpiece "Q", and the convection coefficient "h", based on the temperature-time curves;
- Values found for "Q" and "h" showed lower heat transferred to the workpiece when using flooded system (15 to 25 J) and

highest when using dry condition (20 to 25 J). Convection coefficient was highest for the flooded system (10,000 W/(m².°C)) and lower for the dry condition (100 W/(m².°C)). It can be considered that the MQL system is between both systems with 25 J and 100 W/(m².°C), although closer to the dry conditions.

Acknowledgments

We extend our sincere thanks to all the people who have contributed to the present work, in special to Titex-Prototype in Brazil (Eng. Marcos Soto Ice) and Frankfurt (Dr.-Ing. Roland Heiler), to Dr. Luis A. Colembergue Klujszo from Gerdau-Aços Finos Piratini, and also to FAPEMIG – Brazil.

References

Abukhshim, N.A., Mativenga, P.T., Sheikh, M.A., 2006, "Heat generation and temperature in metal cutting: a review and implications for High Speed Machining". *International Journal of Machine Tools and Manufacture*, Vol. 46, pp. 782-800.

Aneiro, F.M., Coelho, R.T.; Brandão, L.C., 2008, "Turning hardened steel using coated carbide at high cutting speeds". *Journal of Brazilian Society Mechanical Science & Engineering*, Vol. 30, No. 2, pp. 104-109.

Bejan, A., 1997, "Heat Transfer". 2nd. ed. J. Willy & Sons, USA.

Belluco, W. and De Chiffre, L., 2001, "Testing of vegetable-based cutting fluids by hole making operations". *Lubricating Engineering*, pp. 12-16.

Brandão, L.C. and Coelho, R.T. 2009, "Temperature and heat flow when tapping of the hardened Steel using different cooling systems". *Ingeniaria. Revista Chilena de Ingeniería*, Vol. 17, No. 2, pp. 267-274.

Brandão, L.C., Coelho, R.T., Rodrigues, A.R., 2008, "Experimental and theoretical study of workpiece temperature when end milling hardened steels using (TiAl)N-coated and PcBN-tipped tools". *Journal of Materials Processing Technology*, Vol. 199, No. 1-3, pp. 234-244.

Cao, T. and Sutherland, J.W., 1998, "Investigation of thread tapping load characteristics through mechanics modeling and experimentation". *International Journal of Machine Tools & Manufacture*, Vol. 42, pp. 1527-1538.

Carlsaw, H.S. and Jaeger, J.C., 1986, "Conduction of Heat in Solids". London: 2.ed. Oxford, 510 p.

Flannery, W.H., Teukolsky, B.P., Vetterling, W.T., 1990, "Numerical Recipes in Pascal – The Art of Scientific Computing". Cambridge: Cambridge University Press.

Heisel, U., Lutz, M., Spath, D., Wassmer, R., Walter, U., 1998, "A técnica da quantidade mínima de fluidos e sua aplicação nos processos de corte". *Revista Máquinas e Metais*, pp. 22-38.

Incropera, F.P. and Dewitt, D.P., 1990, "Fundamentals of Heat and Mass Transfer". 3rd. ed New York : Wiley, 919 p.

Komanduri, R and Hou, Z.B., 2000, "General solutions for stationary/moving plane heat source problems in manufacturing and tribology". *International Journal of heat and Mass Transfer*, Vol. 43, pp. 1679-1698.

Leshock, C.E. and Shin, Y.C., 1997, "Investigation on cutting temperature in turning by a tool – work thermocouple technique". *Journal of Manufacturing Science and Engineering*. Vol. 119, pp. 502-508.

Movahhedy, M.R., Altintas, Y., Gadala, M.S., 2002, "Numerical analysis of metal cutting with chamfered and blunt tools". *Transactions of ASME*, Vol. 124, pp. 178- 188.

Obikawa, T., Kamata, Y., Shinozuka, J., 2006, "High-speed grooving with applying MQL", *International Journal of Machine Tools & Manufacture*, Vol. 46, pp. 1854-1861.

Özisik, N.M., 1980, "Heat Conduction". 2nd. ed. John Wiley & Sons.

Yvonnet, J., Umbrello, D., Chinesta, F., Micari, F., 2005, "A simple inverse procedure to determine heat flux on the tool in orthogonal cutting". *International Journal of Machine Tools and Manufacture*. Vol. 46, p. 820-827.