



2012

# UAV swarm attack: protection system alternatives for Destroyers

Pham, Loc V

Monterey, California : Naval Postgraduate School

---

<http://hdl.handle.net/10945/28669>



Calhoun is a project of the Dudley Knox Library at NPS, furthering the precepts and goals of open government and government transparency. All information contained herein has been approved for release by the NPS Public Affairs Officer.

**Dudley Knox Library / Naval Postgraduate School**  
**411 Dyer Road / 1 University Circle**  
**Monterey, California USA 93943**

<http://www.nps.edu/library>



**NAVAL  
POSTGRADUATE  
SCHOOL**

**MONTEREY, CALIFORNIA**

**CAPSTONE PROJECT REPORT**

**UAV SWARM ATTACK: PROTECTION SYSTEM AL-  
TERNATIVES FOR DESTROYERS**

By

Team Crane

December 2012

Thesis Co-Advisors:

Paul V. Shebalin  
Bonnie Young

**Approve for public release; distribution is unlimited**

THIS PAGE INTENTIONALLY LEFT BLANK

REPORT DOCUMENTATION PAGE		Form Approved OMB No. 0704-0188	
Public reporting burden for this collection of information is estimated to average 1 hour per response, including the time for reviewing instruction, searching existing data sources, gathering and maintaining the data needed, and completing and reviewing the collection of information. Send comments regarding this burden estimate or any other aspect of this collection of information, including suggestions for reducing this burden, to Washington headquarters Services, Directorate for Information Operations and Reports, 1215 Jefferson Davis Highway, Suite 1204, Arlington, VA 22202-4302, and to the Office of Management and Budget, Paperwork Reduction Project (0704-0188) Washington DC 20503.			
1. AGENCY USE ONLY (Leave blank)	2. REPORT DATE December 2012	3. REPORT TYPE AND DATES COVERED Capstone Project Report	
4. TITLE AND SUBTITLE UAV Swarm Attack: Protection System Alternatives for Destroyers		5. FUNDING NUMBERS	
6. AUTHOR(S) Demostenes Balbuena, Michael Casserly, Brandon Dickerson, Stephen Graves, Vicente Maldonado, Bhavisha Pandya, Loc Pham, James Sanders			
7. PERFORMING ORGANIZATION NAME(S) AND ADDRESS(ES) Naval Postgraduate School Monterey, CA 93943-5000		8. PERFORMING ORGANIZATION REPORT NUMBER	
9. SPONSORING /MONITORING AGENCY NAME(S) AND ADDRESS(ES) N/A		10. SPONSORING/MONITORING AGENCY REPORT NUMBER	
11. SUPPLEMENTARY NOTES The views expressed in this thesis are those of the author and do not reflect the official policy or position of the Department of Defense or the U.S. Government. IRB Number_____N/A-----			
12a. DISTRIBUTION / AVAILABILITY STATEMENT Approved for public release; distribution is unlimited		12b. DISTRIBUTION CODE A	
13. ABSTRACT  The Navy needs to protect Destroyers (DDGs) from Unmanned Aerial Vehicle (UAV) attacks. The team, focusing on improving the DDG's defenses against small radar cross section UAVs making suicide attacks, established a DRM, identified current capability gaps, established a functional flow, created requirements, modeled the DDG's current sensing and engagement capabilities in Microsoft Excel, and used Monte Carlo analysis of 500 simulation runs to determine that four out of eight incoming IED UAVs are likely to hit the ship. Sensitivity analysis showed that improving weapon systems is more effective than improving sensor systems, inspiring the generation of alternatives for improving UAV defense. For the eight feasible alternatives the team estimated cost, assessed risk in accordance with the requirements, simulated performance against the eight incoming UAVs, and performed cost benefit analysis. Adding CIWS mounts is the most cost effective alternative, reducing the average number of UAV hits from a baseline of 3.82 to 2.50, costing \$816M to equip the 62-DDG fleet for a 12-year life cycle. Combining that with upgraded EW capabilities to jam remote-controlled UAVs reduces the hits to 1.56 for \$1844M, and combining those with decoy launchers to defeat the radar-seeking Harpy UAVs reduces the hits to 1.12 for \$2862M.			
14. SUBJECT TERMS Swarm, UAV, Force Protection, Monte Carlo, Harpy		15. NUMBER OF PAGES 157	16. PRICE CODE
17. SECURITY CLASSIFICATION OF REPORT Unclassified	18. SECURITY CLASSIFICATION OF THIS PAGE Unclassified	19. SECURITY CLASSIFICATION OF ABSTRACT Unclassified	20. LIMITATION OF ABSTRACT UU

THIS PAGE INTENTIONALLY LEFT BLANK

**Approve for public release; distribution is unlimited**

**UAV SWARM ATTACK: PROTECTION SYSTEM ALTERNATIVES FOR**

Cohort 311–1120 Team Crane

Loc V Pham  
Brandon Dickerson  
James Sanders

Michael Casserly  
Vicente Maldonado  
Demostenes Balbuena

Stephen Graves  
Bhavisha Pandya

Submitted in partial fulfillment of the  
requirements for the degree of

**MASTER OF SCIENCE IN SYSTEMS ENGINEERING**

from the

**NAVAL POSTGRADUATE SCHOOL  
December 2012**

Lead Editor: \_\_\_\_\_  
Michael Casserly

Reviewed By:

\_\_\_\_\_  
Dr. Paul V. Shebalin  
Capstone Project Advisor

\_\_\_\_\_  
Bonnie Young  
Project Advisor

Accepted By:

\_\_\_\_\_  
Cliff Whitcomb  
Systems Engineering Department

THIS PAGE INTENTIONALLY LEFT BLANK

## **ABSTRACT**

The Navy needs to protect Destroyers (DDGs) from Unmanned Aerial Vehicle (UAV) attacks. The team, focusing on improving the DDG's defenses against small radar cross section UAVs making suicide attacks, established a DRM, identified current capability gaps, established a functional flow, created requirements, modeled the DDG's current sensing and engagement capabilities in Microsoft Excel, and used Monte Carlo analysis of 500 simulation runs to determine that four out of eight incoming IED UAVs are likely to hit the ship. Sensitivity analysis showed that improving weapon systems is more effective than improving sensor systems, inspiring the generation of alternatives for improving UAV defense. For the eight feasible alternatives the team estimated cost, assessed risk in accordance with the requirements, simulated performance against the eight incoming UAVs, and performed cost benefit analysis. Adding CIWS mounts is the most cost effective alternative, reducing the average number of UAV hits from a baseline of 3.82 to 2.50, costing \$816M to equip the 62-DDG fleet for a 12-year life cycle. Combining that with upgraded EW capabilities to jam remote-controlled UAVs reduces the hits to 1.56 for \$1844M, and combining those with decoy launchers to defeat the radar-seeking Harpy UAVs reduces the hits to 1.12 for \$2862M.



THIS PAGE INTENTIONALLY LEFT BLANK

# TABLE OF CONTENTS

<b>I.</b>	<b>INTRODUCTION.....</b>	<b>1</b>
	<b>A. BACKGROUND .....</b>	<b>1</b>
	<b>B. NEED STATEMENT .....</b>	<b>2</b>
	<b>C. PROJECT OBJECTIVES.....</b>	<b>2</b>
	<b>1. Analyze USN Destroyer Baseline.....</b>	<b>3</b>
	<b>2. USN Destroyer Gaps Identification.....</b>	<b>3</b>
	<b>3. Identification of Alternatives .....</b>	<b>3</b>
	<b>D. PROJECT TEAM.....</b>	<b>3</b>
	<b>E. SYSTEMS ENGINEERING DESIGN PROCESS .....</b>	<b>4</b>
	<b>1. Background .....</b>	<b>4</b>
	<b>2. Problem Definition.....</b>	<b>5</b>
	<b>3. Needs Analysis.....</b>	<b>6</b>
	<b>4. Gap Analysis.....</b>	<b>7</b>
	<b>5. Design and Analysis of Alternatives .....</b>	<b>7</b>
	<b>6. Modeling and Simulation .....</b>	<b>8</b>
	<b>7. Process Outputs.....</b>	<b>9</b>
	<b>F. STAKEHOLDER ANALYSIS .....</b>	<b>10</b>
	<b>1. Advisors .....</b>	<b>11</b>
	<b>2. Shipboard Electronic Warfare .....</b>	<b>11</b>
	<b>3. Anti-Terrorism / Force Protection (AT/FP) .....</b>	<b>11</b>
	<b>4. Unmanned Aerial Vehicles (UAVs).....</b>	<b>11</b>
	<b>5. User.....</b>	<b>12</b>
<b>II.</b>	<b>PROBLEM DEFINITION .....</b>	<b>13</b>
	<b>A. THREAT ANALYSIS .....</b>	<b>13</b>
	<b>1. Design Reference Missions.....</b>	<b>13</b>
	<b>B. AEGIS DDG DEFENSIVE CAPABILITIES.....</b>	<b>16</b>
	<b>1. Detection Systems.....</b>	<b>18</b>
	<i>a. AN/SPY-1D(V).....</i>	<i>18</i>
	<i>b. Seahawk System: LAMPS Mark III.....</i>	<i>18</i>
	<i>c. Radar System: AN/SPS-67.....</i>	<i>19</i>
	<i>d. Identification Systems .....</i>	<i>19</i>
	<i>e. Electronic Sensing System (ESS).....</i>	<i>19</i>
	<i>f. Navigation System.....</i>	<i>20</i>
	<i>g. Sonar Systems .....</i>	<i>20</i>
	<i>h. EO/IR and FLIR.....</i>	<i>20</i>
	<b>2. Engagement Systems .....</b>	<b>21</b>
	<i>a. Electronic Warfare System (EWS).....</i>	<i>21</i>
	<i>b. Gun Fire Control System.....</i>	<i>22</i>
	<i>c. Missile Fire Control Systems.....</i>	<i>22</i>
	<i>d. Phalanx Weapon System .....</i>	<i>23</i>
	<i>e. Underwater Fire Control System.....</i>	<i>23</i>
	<i>f. Small Arms .....</i>	<i>23</i>
	<b>C. GAP ANALYSIS.....</b>	<b>24</b>

1.	<b>Functional Analysis</b> .....	24
a.	<i>Detect Target</i> .....	25
b.	<i>Control Target</i> .....	26
c.	<i>Counter Target</i> .....	27
2.	<b>High Level System to Function Mapping</b> .....	27
3.	<b>AWS System Traceability</b> .....	30
4.	<b>Capability Gaps</b> .....	30
III.	<b>BASELINE MODELING AND SIMULATION</b> .....	33
A.	<b>METHOD</b> .....	33
B.	<b>MODEL BLOCK DIAGRAM</b> .....	34
C.	<b>BASELINE MODEL RESULTS</b> .....	37
D.	<b>SENSITIVITY ANALYSIS</b> .....	38
1.	<b>Method</b> .....	38
2.	<b>Results/Discussion</b> .....	39
3.	<b>Conclusions</b> .....	43
IV.	<b>REQUIREMENTS ANALYSIS</b> .....	45
V.	<b>SYSTEM ALTERNATIVES</b> .....	49
A.	<b>METHOD</b> .....	49
1.	<b>Generation of Alternatives</b> .....	49
2.	<b>Method for Cost Estimation of Alternatives</b> .....	50
a.	<i>Alternatives Task Identification</i> .....	52
b.	<i>Alternatives Work Load Assessment</i> .....	53
c.	<i>Alternatives Cost Estimation</i> .....	53
3.	<b>Method for Risk Assessment of Alternatives</b> .....	55
B.	<b>FIRE SCOUT WITH UAV RADAR DECOY</b> .....	56
C.	<b>FIRE SCOUT UAV</b> .....	61
D.	<b>ADDITIONAL CIWS</b> .....	65
E.	<b>LAWS (LASER WEAPON SYSTEM)</b> .....	67
F.	<b>ADDITIONAL SMALL ARMS</b> .....	70
G.	<b>ELECTRONIC WARFARE (EW) JAMMING</b> .....	74
H.	<b>SHIP BASED RADAR DECOY</b> .....	77
I.	<b>SMOKESCREEN ALTERNATIVE</b> .....	80
J.	<b>REACTIVE ARMOR</b> .....	84
VI.	<b>SYSTEM ALTERNATIVE MODEL RESULTS AND COST BENEFIT ANALYSIS</b> .....	87
A.	<b>MODEL RESULTS</b> .....	87
1.	<b>LaWS Modeling Results</b> .....	89
2.	<b>UAV Radar Decoy Modeling Results</b> .....	90
3.	<b>Fire Scout Modeling Results</b> .....	91
4.	<b>Additional CIWS Modeling Results</b> .....	92
5.	<b>Additional Small Arms Modeling Results</b> .....	92
6.	<b>Electronic Warfare (EW) Jamming Modeling Results</b> .....	93
7.	<b>Ship Based Radar Decoy Modeling Results</b> .....	94
8.	<b>Smokescreen Modeling Results</b> .....	95

9.	Modeling Results Summary .....	96
B.	COST BENEFIT ANALYSIS.....	97
VII.	CONCLUSIONS AND RECOMMENDATIONS.....	106
APPENDIX A -	TEAM ORGANIZATION .....	108
A-1	TEAM ORGANIZATION .....	108
A-2	TEAM STRUCTURE.....	108
A-2.1	PROJECT LEAD.....	110
A-2.2	DEPUTY PROJECT LEAD .....	110
A-2.3	CONFIGURATION MANAGER .....	110
A-2.4	STAKEHOLDER ADVOCATE TEAM .....	110
A-2.5	NEEDS ANALYSIS AND RESEARCH TEAM.....	111
A-2.6	SYSTEMS ARCHITECTURE TEAM.....	111
A-2.7	MODELING AND DESIGN TEAM.....	112
A-2.8	ANALYSIS TEAM .....	112
A-2.9	DELIVERABLE REVIEW TEAM .....	112
APPENDIX B -	SCHEDULES AND MILESTONES.....	114
APPENDIX C -	SYSTEM ARCHITECTURE.....	116
APPENDIX D -	SYSTEM REQUIREMENTS .....	120
APPENDIX E -	TECHNOLOGY READINESS LEVEL DESCRIPTION.....	126
LIST OF REFERENCES	.....	128
INITIAL DISTRIBUTION LIST	.....	136

THIS PAGE INTENTIONALLY LEFT BLANK

## LIST OF FIGURES

Figure 1 : Systems Engineering Design Process.....	5
Figure 2: DRM - Positions prior to attack. The DDG is en route to a port call.....	14
Figure 3: DRM - Simultaneous UAV Attack .....	16
Figure 4: AWS for DDG 51 Flight IIA Block Diagram (From “Aegis Weapon System; DANCS; COMBATSS 21,” IHS Jane’s 2012).....	17
Figure 5: Functional Hierarchy – Defend DDG from Swarm of UAVs.....	25
Figure 6: OV-2 Defend DDG from Swarm of UAVs.....	28
Figure 7: Model Block Diagram .....	36
Figure 8: Baseline Model: 500 Simulation Runs with 8 Inbound UAVs .....	37
Figure 9: Baseline Model Averages for 500 Simulation Runs with 8 Inbound UAVs.....	38
Figure 10: Model results for increase to detection.....	39
Figure 11: Model results for increase to CIWS accuracy .....	40
Figure 12: Model results for decrease to CIWS cycle time .....	40
Figure 13: Baseline DDG with 5 inbound UAVs .....	41
Figure 14: Baseline DDG with 10 inbound UAVs .....	41
Figure 15: Successive weapon system improvements .....	42
Figure 16: System Requirement identification sources .....	45
Figure 17: Cost Estimation Process .....	51
Figure 18: 2009 DoD Systems Engineering Process Model.....	52
Figure 19: ALE-55, RT-1489 GEN-X (From Electronic Decoy 2011).....	57
Figure 20: ALE-47 Dispensers and associated equipment (From ALE-47 2010).....	58
Figure 21: Fire Scout (from BAE Systems 2012).....	62
Figure 22: Rendering of the LaWS on the CIWS (From Rourke 2011).....	68
Figure 23: Layout of Small Arms Mounts Alternative (After Seaforces.org 2012).....	71
Figure 24: Lockheed Martin’s ALEX system (From Lockheed Martin 2012).....	78
Figure 25: Modeling Parameters for Alternatives .....	88
Figure 26: LaWS Alternative Results .....	89
Figure 27: UAV Radar Decoy Alternative Results.....	90
Figure 28: Fire Scout Alternative Results.....	91
Figure 29: Additional CIWS Alternative Results .....	92
Figure 30: Additional Small Arms Alternative Results .....	93
Figure 31: Electronic Warfare Jamming Alternative Results .....	94
Figure 32: Ship Based Radar Decoy Alternative Results .....	95
Figure 33: Smokescreen Alternative Results .....	96
Figure 34: Cost Benefit Analysis Process.....	97
Figure 35: Cost per DDG vs. Number of Hits for Individual Alternatives .....	102
Figure 36: Cost per DDG vs. Number of Hits for Combinations .....	103
Figure A-37: Team Organization.....	109
Figure A-38: IPT Qualitative Timeline.....	109
Figure B-39: Gantt chart .....	114
Figure C-40: OV-5 IDEF0 Defend DDG from Swarm of UAVs (Level 1) .....	116
Figure C-41: OV-5 IDEF0 Detect Target (Level 2) .....	117

Figure C-42: OV-5 IDEF0 Control Target (Level 2).....	118
Figure C-43: OV-5 IDEF0 Counter Target (Level 2).....	119

## LIST OF TABLES

Table 1: AWS System Traceability Matrix .....	30
Table 2: Sensor Detection Parameters .....	34
Table 3: CIWS Parameters.....	34
Table 4: Small Arms Parameters .....	34
Table 5: UAV Parameters.....	35
Table 6: Baseline Model Sequence of Events Example .....	35
Table 7: Alternative Methods .....	49
Table 8: Cost Estimation Framework .....	50
Table 9: Cost Estimation for Small Arms Mounts Alternative.....	54
Table 10: Risk Assessment (After Defense 2006).....	55
Table 11: Risk Mapping.....	56
Table 12: Fire Scout with UAV Radar Decoy Alternative Risk Assessment.....	59
Table 13: Fire Scout with UAV Radar Decoy Alternative Risk Number Mapping .....	59
Table 14: Fire Scout with UAV Radar Decoy Alternative Cost Estimation .....	61
Table 15: Fire Scout UAV Risk Assessment.....	63
Table 16: Fire Scout UAV Alternative Risk Number Mapping .....	63
Table 17: Fire Scout UAV Cost Estimation .....	65
Table 18: Additional CIWS Alternative Risk Assessment.....	67
Table 19: Additional CIWS Alternative Risk Number Mapping .....	67
Table 20: CIWS Alternative Cost Estimation.....	67
Table 21: LaWS Alternative Risk Assessment.....	69
Table 22: LaWS Risk Number Mapping .....	69
Table 23: LaWS Cost Estimation .....	70
Table 24: Small Arms Mounts Alternative Risks Assessment.....	72
Table 25: Small Arms Mounts Alternative Risks List.....	73
Table 26: Small Arms Mounts Cost Estimation Summary.....	74
Table 27: EW Alternative Risk Assessment.....	76
Table 28: EW Alternative Risk Number Mapping .....	76
Table 29: EW Alternative Cost Estimation .....	76
Table 30: Ship Based Radar Decoy Alternative Risk Assessment.....	78
Table 31: Ship Based Radar Decoy Alternative Risk Mapping .....	79
Table 32: Ship Based Radar Decoy Alternative Cost Estimation.....	80
Table 33: Smokescreen Alternative Risk Assessment.....	81
Table 34: Smokescreen Alternative Risk Mapping .....	82
Table 35: Smokescreen Alternative Cost Estimation .....	83
Table 36: TRAPS Alternative Risk Assessment.....	86
Table 37: TRAPS Alternative Risk Mapping .....	86
Table 38: Alternative Results.....	96
Table 39: Summary of Alternatives Performance .....	98
Table 40: Summary of Cost Benefit Analysis for Individual Alternatives.....	100
Table 41: Summary of Cost Benefit Analysis for Combination of Alternatives .....	101
Table A-42: Team Crane Members .....	108



Table A-43: Team Member Roles .....	113
Table D-44: System Requirements .....	120
Table E-45: TRL Descriptions (From (ASD(R&E)) 2011).....	126

## **LIST OF ABBREVIATIONS AND ACRONYMS**

ADS - Aegis Display System

ALEX - Advanced Countermeasure Decoy Launch System

APKWS - Advanced Precision Kill Weapon System

ASCM - Anti Ship Cruise Missiles

ASUV - Anti-Surface Warfare

ASW - Anti-Submarine Warfare

AT/FP - Anti-Terrorism / Force Protection

AWS - Aegis Weapon System

C&D - Command and Decision System

CIWS - Close-In Weapons System

CROWS - Common Remotely Operated Weapon Station

DDG - Guided Missile Destroyers

DLS - Decoy Launch System

DoD - Department of Defense

DoN - Department of the Navy

DRM - Design Reference Mission

EOSS - Electro-Optical Sensor System

ESS - Electronic Sensing System

EW - Electronic Warfare

EWS - Electronic Warfare System

FY - Fiscal Year

GEN-X - Generic Expendable

GPS - Global Positioning System

GWS - Gun Weapon System

ICD - Initial Capabilities Document

IED - Improvised Explosive Device

IMS - Integrated Master Schedule

IPT - integrated product teams

LaWS - Laser Weapon System  
LCS - Littoral Combat Ship  
M&S - Modeling and simulation  
MES - Maritime Expeditionary Security  
MGS - Machine Gun Systems  
MIL-STD - Military Standard  
MOE - Measure of Effectiveness  
MSSE - Masters of Science in Systems Engineering  
NAVSEA - Naval Sea Systems Command  
NPS - Naval Postgraduate School  
ODPS - Onboard Destroyer Protection System  
OSD - Object Storage Device  
RCS - Radar Cross Section  
SA - Situational Awareness  
SEWIP - Surface Electronic Warfare Improvement Program  
TRAPS - Tactical Rocket-Propelled Grenade Airbag Protection System  
TRL - Technology Readiness Level  
UAV - Unmanned Aerial Vehicle  
USN - United States Navy  
WCS - Weapon Control System

## EXECUTIVE SUMMARY

To improve a DDG's defense against suicide UAV attacks, the most cost-effective upgrades include installing two additional CIWS mounts, upgrading EW capabilities to jam remote-controlled UAVs, and installing radar decoy launchers to defeat radar signal-seeking UAVs such as the Harpy. Simulation shows that against a mixed attack swarm of four remotely controlled UAVs and four Harpy UAVs, about four of eight incoming IED UAVs are likely to hit the baseline DDG without upgrades. Adding two CIWS mounts reduces the average number of UAV hits scored on the DDG from a baseline of 3.82 to 2.50, costing \$816 million U.S. dollars to equip the 62-DDG fleet for a 12-year life cycle, or \$13.2 million U.S. dollars per DDG. Combining the CIWS installations with upgraded EW capabilities to jam remote-controlled UAVs reduces the hits to 1.56 for \$1844 million U.S. dollars, or \$29.7 million U.S. dollars per DDG. Installing radar decoy launchers in addition to the CIWS and jammer upgrades reduces the hits to 1.12 for \$2862 million U.S. dollars, or \$46.2 million U.S. dollars per DDG. All of these estimates are in FY 2013 dollars.

The objectives of this project are to analyze the current United States Navy (USN) destroyer baseline capabilities for defending against UAVs, identify the capability gaps, generate alternatives for UAV defense, and use systems engineering techniques to determine the most cost-effective options for defending against UAV threats.

The team first investigated the user need relating to UAVs, and found that UAVs are included in a need statement from the Maritime Expeditionary Security (MES) force Initial Capabilities Document (ICD): "Point defense capability to defend against limited air threats that penetrate Sea Shield local air defense umbrellas. The threat includes light civilian (general aviation) aircraft, small commercial aircraft and small radar cross-section targets such as UAVs" (N857 2007).

With the user need established, the team defined the Design Reference Mission (DRM), deciding to focus on the suicide UAV threat in a littoral environment. In the DRM, a DDG visiting a foreign port is spotted by non-state actor enemies, triggering the launch of 5 to 10 UAVs. Each UAV is fitted with an explosive payload, and because

some of the UAVs operate autonomously, the UAV operators attempt to attack the DDG with remotely controlled UAVs at the same time as the autonomous UAVs lock on to and attack the DDG's radar.

Some of the DDG's current systems are appropriate for combating the UAV threat, but with others there is a significant gap. For the first step of the gap analysis, the team identified the current DDG systems and their capability to detect, track, and engage targets. The team further decomposed the detect-to-engage sequence in a functional flow. Detection includes classifying the contact as a UAV and identifying it as a threat. Defensive systems are assigned to tracked targets, and after engagement, battle damage assessment feeds back into defensive system assignment. The flow continues until the encounter ends with no targets remaining.

The team established a model of the baseline DDG using Microsoft Excel. The baseline model reflects an operational environment based on the DRM. The team analyzed and researched the current capabilities the DDG has to defend against a UAV swarm attack, and the identified information established input placeholder values for the baseline model. In order to keep this baseline model UNCLASSIFIED, the parameters are based on accessible publicly available data and assumptions for the unknowns. The team performed Monte Carlo analysis of 500 simulation results for a swarm of 8 UAVs attacking a DDG, as the goal was to output the number of inbound UAVs which score a hit on the DDG. Based on the simulation results, the baseline DDG would experience a significant amount of UAV hits; the most likely outcome is for four UAVs to hit the ship.

With the model in place for the baseline DDG, a sensitivity analysis showed which types of improvements yielded the greatest effect on the model's outcome. The sensitivity analysis involved varying several input parameters individually and comparing how each affected the number of hits scored by UAVs, so that system alternatives could focus on improving the most important parameters. The analysis showed that improving the ship's sensors is not as effective as making weapon system improvements. Weapon systems would have to be improved a significant amount before the improvements' effectiveness becomes limited by targets evading sensor detection. Therefore, the team investigated system alternatives which focus on neutralizing, not detecting, UAVs.

Brainstorming generated many possible alternatives which the team then narrowed based on the sensitivity analysis results; alternatives which only improve detection were excluded. The team selected all but the most infeasible remaining alternatives, including upgrading the CIWS with the Laser Weapon System (LaWS), upgrading EW capabilities to jam remote control UAVs, procure a UAV to control from the DDG such as the Fire Scout and install onboard weapons to shoot down UAVs, launching radar decoys from the ship's Fire Scout, installing additional small arms mounts on the DDG, installing radar decoy launchers on the DDG, installing reactive armor, using smoke generators to obscure the DDG and make guidance difficult for remotely controlled UAVs, launching a shrapnel-like chaff which would tear apart UAVs flying through it, and installing additional CIWS mounts. After some research, the team found reactive armor and the shrapnel chaff option to not be technologically feasible.

For each remaining alternative, the team estimated cost, assuming a five-year procurement and installation period (after system development and test) and a 12-year life cycle for sustainment. The team also assessed risk for each alternative, considering what obstacles could prevent that alternative from being implemented on the DDG as well as what could prevent it from performing its full intended purpose successfully. Risks were evaluated for each applicable system requirement, and included any suitability considerations, as well as technology readiness.

To assess effectiveness for each alternative, the team conducted a simulation of 500 trials, and each trial resulted in a number of UAV hits scored on the DDG ranging from zero to eight. In order to demonstrate each alternative's percent decrease in UAV hits scored on the DDG from the baseline model, the average number of UAV hits was recorded for both the baseline and the alternatives. Installing two additional CIWS mounts reduced the baseline number of hits the most, from 3.82 to 2.50. CIWS was followed in modeled effectiveness by the EW remote control UAV jammer (2.57 hits), the Fire Scout-launched radar decoys (2.81 hits), the ship-launched radar decoys (3.05 hits), and the smokescreen alternative (3.24 hits), while the other alternatives yielded negligible improvement.

Dividing the difference between hits scored with an alternative and hits scored with the baseline by the alternative's cost allowed the alternatives to be ranked by cost

effectiveness. The team used the same method to find the cost effectiveness of combinations of the top three alternatives, resulting in the three upgrade options.

# I. INTRODUCTION

## A. BACKGROUND

With respect to the 21st Century, it is projected that future threats in addition to being deadly will be increasingly varied in their form and more widely dispersed. Future threats will be implemented with little warning of the intended target and size of the attack. It is believed that in order to address these future challenges, the USN needs to evolve its previous strategy of maintaining a regional focus, to include transnational threats. In order to address these future challenges, the USN needs to further increase its capabilities to conduct sustained sea to land operations and increase the distance of its offensive capabilities. As is expressed in “Sea Power 21: Projecting Decisive Joint Capabilities,” the vision for the USN is to increase its operational capabilities in order to address the future threats (Clark 2002).

From “Sea Power 21,” there are three fundamental concepts that express the vision of the USN’s increased operational capabilities: Sea Power in the 21<sup>st</sup> century involves what are referred to as Sea Strike, Sea Shield, and Sea Basing. Sea Strike refers to the ability of the USN to project precise and persistent offensive power from sea. Sea Shield refers to the ability of the USN to provide defensive assurance throughout the world. Sea Basing refers to the ability of the USN to increase operational independence and support for joint forces (Clark 2002).

Maritime Expeditionary Security (MES) forces are but one organization to assist in making Sea Power 21 a reality. The purpose of MES forces is to assist sea basing operations by protecting the transit of supplies and additional assets required to sustain the operation. In addition, MES forces are to provide point defense for individual vessels, harbors, inland waterways, facilities, and stationed equipment in littoral regions. As a result, one of the core capabilities identified in the MES Initial Capabilities Document (ICD) is to “detect, identify, engage, and destroy Level I and Level II hostile air, surface, subsurface, and ground targets, day and night, and in most weather conditions in the littoral battle space” (N857 2007). Currently, MES forces are unable to adequately fulfill this capability. An unmanned aerial vehicle (UAV) can carry missiles or act as an Improvised



Explosive Device (IED), and could be employed by terrorists (Level I threat) or be part of irregular (Level II threat) forces (N857 2007).

Part of the Arleigh Burke-Class Aegis Guided-Missile Destroyer Flight IIA (DDG) mission is to assist expeditionary strike groups in littoral offshore warfare scenarios (Vandroff 2012). A DDG partaking in an expeditionary strike group mission could be exposed to the threat of UAVs acting as IEDs. The UAV swarm threat becomes increasingly credible as adversaries develop low cost implementations. Low cost implementations are made possible due to the low level of technology required to create UAVs acting as IEDs. As a result, DDGs could face a swarm of attacking UAVs that have minimal autonomy and require that the operator maintains a line of sight with the aircraft and its intended target. In addition, other UAVs that require little to no manual operations may also be used.

The combat systems of a DDG are centered on the Aegis Weapon System (AWS) (Gryphon Technologies 2011). The early design of the AWS focused on countering air threats that included aircraft and anti-ship cruise missiles (ASCM), but was later upgraded to incorporate capabilities able to counter ballistic missiles (“The AEGIS Combat System,” Threston 2009). Characteristics common to these threats include fast flying speeds and large radar cross sections. While on a mission to assist MES forces, it is envisioned that a DDG will be threatened by UAVs that have slow flying speeds and small radar cross sections. Therefore, there is sufficient evidence to believe that the DDG may be vulnerable to UAVs acting as IEDs in an MES setting.

## **B. NEED STATEMENT**

The USN needs to ensure that a DDG has the capability to defend against a swarm of UAVs, acting as IEDs, in an MES setting.

## **C. PROJECT OBJECTIVES**

The objectives of this project are to analyze the current USN destroyer baseline capabilities for defending against UAVs, identify the capability gaps, generate alternative

architectures for UAVs defense, and use systems engineering techniques to determine the most effective and cost-effective options for defending against the threat of UAVs.

### **1. Analyze USN Destroyer Baseline**

Understanding the USN destroyer baseline for shipboard protection against UAV swarm attacks is the first objective. Information pertaining to USN destroyer shipboard protection system capabilities and system architecture is obtained from open sources and unclassified documents from stakeholders. The baseline is used to identify gaps and to compare with alternative options for USN destroyer protection against UAVs swarm attacks.

### **2. USN Destroyer Gaps Identification**

Identifying capability gaps is the second objective. Modeling and simulation is used to analyze the performance of USN destroyer baseline capabilities against UAV swarm attacks in accordance with the user's operational environment.

### **3. Identification of Alternatives**

Generating alternative systems for protecting USN destroyers from UAV swarm attacks is the third objective. Based on the available current system baseline and the result from the capability gaps identification, the systems engineering process is used to develop alternative systems for the DDG in defense against UAV swarm attacks. Data from system modeling and simulation is used to compare the performance of the proposed architectures to the current baseline. The proposed alternatives and the results from modeling and simulation are presented to stakeholders for system development candidate selection.

## **D. PROJECT TEAM**

The project team, referred to as Team Crane, consists of eight members enrolled in the Naval Postgraduate School Masters of Science degree for Systems Engineering. The project team consists of six integrated product teams (IPTs), along with a project

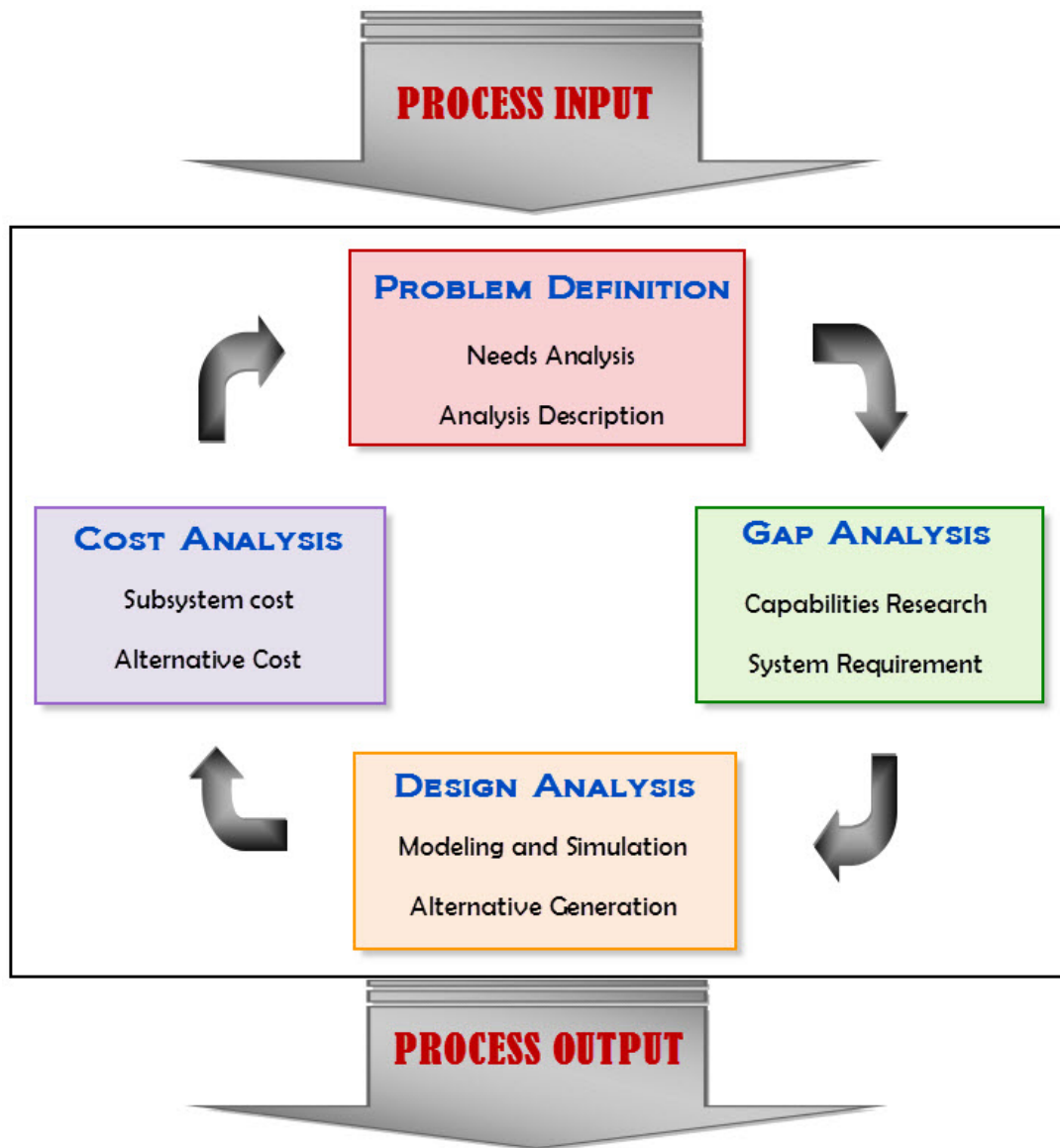
lead, deputy project lead, and configuration manager. The six IPTs include the Stakeholder Advocate Team, Need Analysis and Research Team, Systems Architecture Team, Modeling and Design Team, Analysis Team, and Deliverable Review Team. An IPT structure was chosen in order to maintain tasking flexibility and to promote teamwork. Not all of the IPTs were in existence throughout the duration of the project. The IPTs were created when the need arose and members of the IPTs gradually joined other IPTs, as various tasks were completed. Therefore, flexibility was maintained by increasing or decreasing the number of members on each team, in order to meet the scheduled deliverables outlined in the Integrated Master Schedule (IMS). However, in order to accommodate for an iterative process throughout the project, at least one team member was responsible for maintaining and updating previous deliverables of all IPTs. Because team members were a part of a small team throughout the duration of the project, effective communication and relationships were established, thus promoting teamwork. For more details see Appendix A.

## **E. SYSTEMS ENGINEERING DESIGN PROCESS**

### **1. Background**

In order to accomplish the study of this problem, Team Crane applied a Systems Engineering process adopted from a process developed by Blanchard and Fabrycky (2006). In coming up with a solution for the proposed topic, “Protection System Alternatives for Destroyers against UAV Swarm Attack,” Team Crane used a conceptual design process. During the conceptual design, the team first identified the primary stakeholders. Next, the team generated a problem statement identified by the stakeholders, and through iterative correspondence between the team and the relevant stakeholders, transformed it into an effective need. The effective need statement provided Team Crane with the ability to begin identifying the system’s operational requirements. By identifying the operational requirements, Team Crane was able to create a high-level operational concept, the relevant operational nodes, and the mission tasks (OV-1, OV-2, and OV-5, respectively). Finally, from analysis of the effective need, OV-1, and OV-5, and modeling and simulation, Team Crane developed functional requirements, identified alternative solutions, and

compared the utility of possible solutions. The systems engineering process is illustrated in Figure 1.



**Figure 1 : Systems Engineering Design Process**

## **2. Problem Definition**

The problem statement was vital to be addressed at the beginning of the project as it set the direction of the project for the team. The first initiative to scope and bound the problem was by developing a problem statement that provided the team with a defined idea from the stakeholder requirements. The stakeholder requirements helped the team to

address the various design functions of the systems engineering design process that consist of major inputs and outputs. In early development of the systems engineering design process, the team focused on defining the major inputs and outputs of the problem statement. The inputs address the concerns and complaints by the stakeholders and the outputs define the Measure of Effectiveness (MOE) and desired constraints.

### **3. Needs Analysis**

The Needs Analysis identifies and defines the objectives of the project. An effective need statement was developed from the stakeholders' requirement needs. From a document provided by a stakeholder, the following statement provides the team with a primitive user need statement: "Point defense capability to defend against limited air threats that penetrate Sea Shield local air defense umbrellas. The threat includes light civilian (general aviation) aircraft, small commercial aircraft and small radar cross-section targets such as UAVs" (N857 2007).

From this statement, the team focused on the stakeholders' interest in defending a destroyer from a particular threat in this scenario. Based on stakeholder guidance, the team analyzed the threat scenario of small UAVs making suicide attacks against a destroyer.

These scenarios do not have a defined environment in which the threat could potentially have a major impact. Because of this, the team engaged the stakeholders in order to determine the optimal scenario.

The scope of the project concentrates on the stakeholders' desires to enhance their air defense capabilities against UAVs. The scope allowed the team to identify the needs of the stakeholder, the objectives for the system, and the criteria based on the threat. These functions of the system level design process follow the scope and effective need statement:

- Develop Operational Concept
  - Description of how the system will be utilized
  - Mission requirements and MOEs
- Define System Boundary
  - External system boundaries generated from operational concept baseline

- Input-output model
- Develop System Objectives
  - Operational concept inputs
  - System level hierarchy of objectives

#### **4. Gap Analysis**

Once the requirements were fully understood from the stakeholders, a design reference mission (DRM) was established. The DRM defines the specific projected threat and operating environment baseline for the destroyer, which may range from a single mission platform to a multi-mission system platform. Important to note is that the DRM defines the problem, not a solution, by characterizing the complete operating environment to the baseline of this project.

The DRM was developed based on the understanding of the user's operational concept that was derived from the stakeholder needs. Based on these requirements, a simulated environment was developed that best suits the DRM. The operational environment is the environment in which the destroyer has to operate and defend itself from UAV swarms, and this project focuses on the environment where the destroyer is near the shore. In any mission-executable environment, the project team was able to exercise the destroyers' capabilities. Given the DRM for this project, a feasibility analysis was conducted to determine different approaches for defending against UAV swarm attack.

The gap analysis identifies current capabilities for defending against a UAV attack. It also identifies areas where current capabilities do not match the threat; these capabilities provide the input parameters for a model of the system. Modeling and simulation was first used to establish the performance of the baseline destroyer against the UAV swarm threat, making use of current destroyer capabilities and planned upgrades over the next few years.

#### **5. Design and Analysis of Alternatives**

After understanding the problem definition and the user need, the project team conducted further research into identifying potential alternatives to the system. The team generated two or three alternative architectures to compare with each other and the base-

line. Through the decomposition of architectures, the team evaluated the best system of alternatives through the various factors, such as modeling and simulation, life cycle cost, tradeoff-analysis, and risk analysis. These factors have an impact on the decision making phase that is part of the project plan. As alternatives were generated, they were evaluated to ensure they met stakeholder requirements, were conceptually viable, and had sufficiently low risk. Different types of tools were used to assist in this evaluation.

Modeling and simulation generates detailed data for the given scenario that is set based on the alternatives for improvements to the destroyer's capabilities. The advantage of pursuing such a tool allowed the team to evaluate the effectiveness of an alternative concept, verify stakeholder's needs are met, and suggest modifications for improving alternatives.

The life cycle cost estimation for each improvement alternative ties into the decision making process as it contributes to the analysis of alternatives. These estimates take into consideration the developmental design and integration, production, operational use, refinement, and disposal of the system.

The trade-off and risk analysis ranks the improvement alternatives, taking into account life cycle cost, technical risk, and ability to successfully defend the destroyer against the threat swarm in accordance with the stakeholder requirements. These factors were used to determine the feasibility of identified alternatives.

The decision making criteria of this phase feeds from the results of alternatives to the system. In order to evaluate the alternatives equally, the team focused on cost benefit analysis, value modeling, and decision matrices. The conclusion of these analyses ultimately recommends the best suitable alternative for the stakeholders' interest.

## **6. Modeling and Simulation**

In an effort to maximize the level of accuracy in the project, a wide variety of tools were employed to meet the user's needs and stakeholders' requirements. Project planning and the development of solutions based on stakeholders' requirements involve a high level of organization. The following tools provide the necessary support to organize collected data, analyze statistical data, model scenarios, and collaborate effectively as a team.

- **CORE 8** is a comprehensive modeling environment used for complex systems engineering problems. It is used for integrated requirements management to ensure that stakeholders' needs are being taken into consideration. This software allows the generation of a variety of integrated graphical views: hierarchies, functional flow, enhanced functional flows, N2, IDEF0, and physical block (Vitech n.d.).
- **Illuminate** is a web conferencing program frequently used by educational entities and business to hold meetings and provide training. Students and instructors do not reside in the same geographical location; Illuminate sessions between students and professors are generally conducted on a weekly basis. This tool allows students to stay in contact with the instructors. Constant communication provides the necessary level of support to deliver effective solutions to stakeholders' needs.
- **Sakai** is the Naval Postgraduate School student webpage. Documentation generated by group members can be saved on the webpage. It provides another communication channel to share ideas and files.
- **Microsoft Office Suite** is a compilation of desktop programs that run on the Microsoft Windows or the Mac OS X operating system. The programs are designed to fulfill specific needs like creating or editing Word documents, spreadsheets, presentations, and meeting requests.
  - **Microsoft Word** is word processor that is used to create and edit documents.
  - **Microsoft Excel** is a dynamic spreadsheet that is used to model operational scenarios for Navy ships and to perform other statistical and mathematical calculations. Excel is used to model the performance of the DDG against UAV swarms, and produces a high enough fidelity model for the desired outputs. Monte Carlo analysis is used to simulate the range of probable outcomes.
  - **Microsoft Project** is a management tool that is used track group members' tasks, schedules, and roles.

## 7. Process Outputs

The capstone project team provided the following outputs:



- A project report containing:
  - A summary of the systems engineering tools and methods used
  - Analysis of alternatives, including models and simulations
  - Preferred system concept
  - Recommendations/conclusions for follow-on system development
- A final presentation

The analysis results in several products. First, it identifies how effective various potential improvements to a destroyer's systems are at combating the threat UAVs. At minimum, this involves comparing the relative effectiveness of making destroyer improvements, allowing the stakeholders to determine which improvements provide the most benefit.

Second, the analysis identifies which combination of improvements defeats the threat UAVs. Whereas the first analysis product identifies the effectiveness of single improvements, the second involves combinations because single improvements may not be enough to defend against the threat.

The third analysis product is the result of adding in cost information. The costs of each potential improvement and combination of improvements were estimated. This information allowed the team to rank the improvements by cost and effectiveness, displaying to the stakeholders the most cost-efficient ways to make destroyer improvements against the UAV threat, and how much effectiveness is gained through the application of given funding.

## **F. STAKEHOLDER ANALYSIS**

The stakeholders identified below constitute the initial list; the team used the initial stakeholders as starting points in the search for additional parties with a possible interest in the results of the capstone project, as well as additional sources of technical information.

## **1. Advisors**

The capstone project advisors were responsible for guiding the students who were team members of the capstone project. They were also responsible for attending Team Crane team meetings and providing feedback on the capstone project.

## **2. Shipboard Electronic Warfare**

The NSWC Crane shipboard Electronic Warfare Chief Engineer is the point of contact for the project technical information of Electronic Warfare (EW) shipboard protection system. The EW Chief Engineer is the key stakeholder for EW shipboard protection system capabilities and gaps. The EW Chief Engineer provided information on current capabilities to Team Crane during the capabilities analysis for gaps identification as well as information pertaining to potential EW solutions.

## **3. Anti-Terrorism / Force Protection (AT/FP)**

The Naval Sea Systems Command (NAVSEA) AT/FP Technical Warrant Holder is the primary stakeholder for the project technical information of non-EW shipboard protection systems. The NAVSEA AT/FP Technical Warrant Holder is the key stakeholder for non-EW shipboard protection systems capabilities and gaps. The NAVSEA AT/FP Technical Warrant Holder provided the information of current capabilities to Team Crane during the capabilities analysis for gaps identification as well as the project scope and scenarios.

## **4. Unmanned Aerial Vehicles (UAVs)**

Engineers at NSWC Crane have performed research in UAVs and autonomous systems, and are the primary stakeholders for the technical information on UAVs. They provided the information related to UAV capabilities for the project scenarios and capabilities gaps.

## **5. User**

The user is the United States Navy. The U.S. Navy is the primary stakeholder for the capstone project. The U.S Navy provides required capabilities and system requirements. The U.S. Navy has a potential interest in the requirements and analysis produced in the capstone project.

## **II. PROBLEM DEFINITION**

Conversations with the stakeholders, in conjunction with additional research, were used to identify realistic mission scenarios in which a DDG may find itself being attacked by a swarm of UAV without the support of additional ships.

### **A. THREAT ANALYSIS**

#### **1. Design Reference Missions**

The DDG operating scenario analyzed in this project consists of a near shore littoral combat region with a significant amount of other activities in the environment. The environmental activities include the daily activities that one would notice from a typical day to day observation. Such activities would account for the DDG operating within a close distance of residential locations, populated areas of fishing boats, outdoor markets, and other civilian locations.

A swarm of UAVs consisting of 5 to 10 vehicles will aim to come at the DDG from all directions. The UAVs will be launched at the DDG when the enemies are in position and can coordinate the timing of their individual launches, and when the DDG comes within sight of the enemy spotters. The DDG will be spotted by the enemy using binoculars from a mountaintop observation point near shore. Visibility is assumed to be good enough that binoculars can detect the DDG from at least a range of 24 km. At this point, the DDG will be at approximately 68 km from the port. It will take approximately 3 hours for the DDG to reach the port travelling at 12 knots. The UAVs, each fitted with an explosive payload, will be launched with a mission to fly into the DDG as a suicidal attack. The destroyer's plan of action to defeat a swarm of UAVs will follow the functional flow that lays out the main top level functions to attempt to eliminate the threat (Detect, Prioritize, Track, and Engage). Figure 2 shows the positions of each launch area, foreign port, and where the DDG is located prior to the attack.

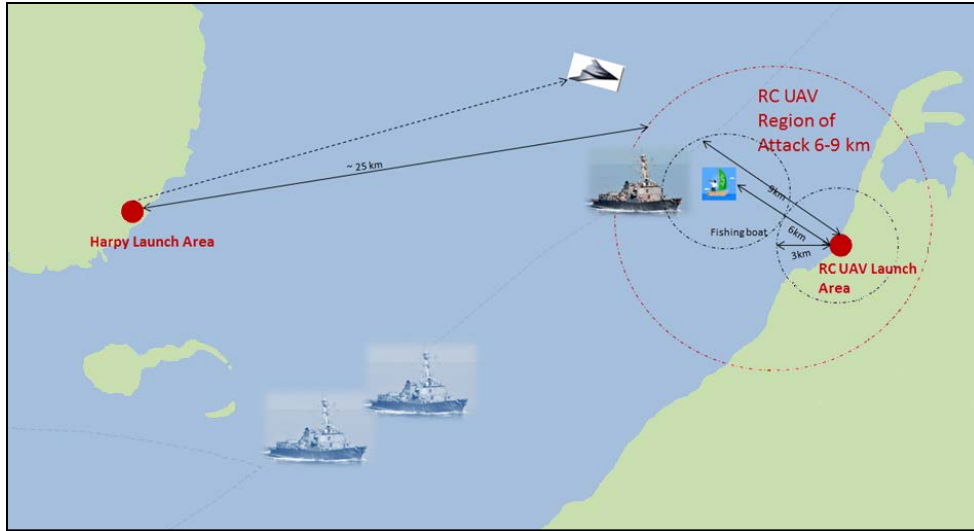


**Figure 2: DRM - Positions prior to attack. The DDG is en route to a port call.**

The two types of threats against the DDG are RC controlled UAVs and UAVs with similar capabilities to the Harpy. The Harpy is an autonomous UAV that produces a small Radar Cross Section (RCS) and will be equipped with an explosive warhead for a suicidal attack. The Harpy is a pre-programmed UAV that follows a loitering pattern until it detects radar signals from the communication systems of a destroyer. The Harpy is launched from a ground-based battery comprised of three launching units which are 1) a vehicle ground control shelter, 2) a support vehicle, and 3) an electric power unit. These vehicles can be positioned in a populated area for a quick and easy launch location. There are four Harpies in the scenario. The Harpy launch area will be located near the bay. The Harpy has at least a 3 km detection range (X8R 2.4Ghz 8ch Receiver n.d.). It travels at 250 km/h. (Jane's Unmanned Aerial Vehicles and Targets 2011). It will launch 1.5 hours after the DDG is spotted. The RC UAV has a small RCS and will be equipped with explosive warheads. The RC UAVs are cost effective weapons that can be constructed through commercial off the shelf (COTS) parts. Despite their minimal operational range, these threats are envisioned to be launched from a shore that the DDG may be cruising

past and where an enemy could blend into the public. Also, the attack in this scenario happens during the day with good visibility and weather conditions.

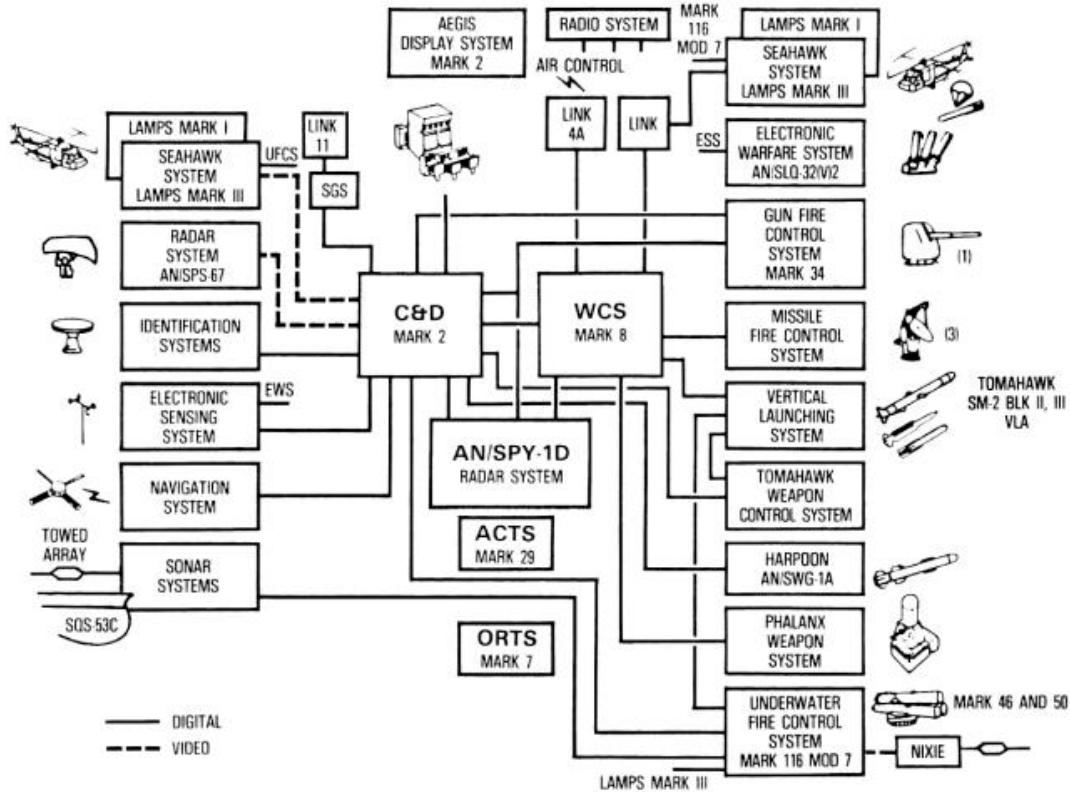
The RC UAVs are launched from the shore as depicted in Figure 2, and their remote control range is at least 3 km (X8R 2.4Ghz 8ch Receiver n.d.). Also, RC UAVs fly low to the water's surface. The fishing boat is located 6 km from the RC UAV launch pad. Once the RC UAVs go out of range from the controllers located at the launch pad, people on the fishing boat will control the RC UAVs. The RC UAVs will launch about 2 hours after the DDG is spotted initially, or when the DDG is spotted from the RC UAV launch pad. The RC UAVs travel 250 km/h (Goolsbee n.d.). Harpies would hover up to 2 hours around the attack area. At this point, the DDG is about 20 km away from the port. Figure 3 shows the simultaneous UAV attack when the DDG is closer to the foreign port. Since the RC UAV attack range is 3 km, the fishing boat is located 6 km from the RC UAV launch area, as shown in Figure 3. The fishing boat could be anywhere within 6 km of the RC UAV launch location, so the possible region of attack for the RC UAVs occupies 6–9 km of the DDG's intended route. Harpies and RC UAVs will attack the DDG at the same time, with the Harpies attacking from the Northeast and RC UAVs attacking from the Southeast. Both Harpies and RC UAVs are assumed to be equally difficult to shoot down because of their speed and RCS. Both would cause the same amount of damage on the DDG.



**Figure 3: DRM - Simultaneous UAV Attack**

## **B. AEGIS DDG DEFENSIVE CAPABILITIES**

The current design of the DDG 51 Flight IIA is centered on the AWS. As previously stated, the Aegis Weapon System was primarily designed to counter targets flying at fast speeds with large radar cross sections. A swarm of UAVs, as defined in the previous section, flies at significantly slower speeds and has significantly smaller radar cross sections, compared to the targets the AWS was designed to counter. This section explores the current capabilities and limitations of the DDG with regard to countering a swarm of UAVs. Figure 4 is a block diagram of the DDG AWS.



**Figure 4: AWS for DDG 51 Flight IIA Block Diagram (From “Aegis Weapon System; DANCS; COMBATSS 21,” IHS Jane’s 2012)**

Four of the main components of the AWS, as seen in Figure 4, are the Aegis Command and Decision System (C&D), the Aegis Display System (ADS), the Aegis Weapon Control System (WCS), and the AN/SPY-1 radar system. The C&D acts as an integrator for all of the combat systems and is responsible for the command, control, and coordination of the AWS (“Aegis Weapon System; DANCS; COMBATSS 21,” IHS Jane’s 2012). The C&D acquires and processes the data from the SPY-1 radar and other detection systems as depicted in Figure 4, and relays the tactical information to the ADS and the WCS. The ADS provides the necessary displays and controls for human coordination of the AWS. It is from the ADS that a complete tactical picture is displayed and strategic commands are issued. Upon receiving an engagement order from the C&D, the WCS assigns a weapon system to the target and conducts the engagement using tracking data provided from the SPY-1 radar system (“The AEGIS Weapon System,” Threston 2009). As depicted in Figure 4, the weapon systems under control of the WCS include the



Missile Fire Control System, Vertical Launching System, Seahawk System, and the Phalanx Weapon System.

The majority of the AWS detection systems are found on the left-hand side of Figure 4, with the exception of the SPY-1 radar system, and the AWS engagement systems are found on the right-hand side of Figure 4. The remaining systems, such as Link 11, are outside the scope of this report. The remainder of this section will discuss the detection and engagement systems in greater detail and if they are applicable to countering a swarm of UAVs.

## **1. Detection Systems**

### ***a. AN/SPY-1D(V)***

The AN/SPY-1D(V) radar system was first implemented on DDG 91 (“Arleigh Burke (Flight IIA) class,” IHS Jane’s 2012). The radar consists of four phased array antennas that provide the AWS with 360 degree detection and tracking capabilities (“The AEGIS Weapon System,” Threston 2009). The radar was designed primarily as a surface and air radar capable of simultaneously tracking over one hundred targets (“AN/SPY-1 Radar,” Global Security 2012). The capabilities upgraded specifically in the AN/SPY-1D(V), over previous variants of the SPY-1 radar, improved the radar’s ability to detect low-flying targets with small radar cross sections (RCS) and operate in heavily cluttered environments (“AN/SPY-1 Radar,” Global Security 2012). Previous variants were limited to only searching above the terrain in littoral settings, in order to prevent having a high false alarm rate due to land clutter (“AN/SPY-1 Radar,” Global Security 2012). Although this issue was addressed in the AN/SPY-1D(V) design, it is not confirmed to what extent the limitations were reduced. Therefore, this report assumes that the AN/SPY-1D(V) can detect UAVs but may have trouble with low flying targets.

### ***b. Seahawk System: LAMPS Mark III***

The LAMPS Mark III is an airborne platform designed for Anti-Surface Warfare (ASUW), and Anti-Submarine Warfare (ASW) (“Sikorsky SH-60B Seahawk (LAMPS Mk III),” IHS Jane’s 2012). Due to the fact that LAMPS Mark III was not specifically

design to counter airborne threats, this system would not be effective in countering a swarm of UAVs.

*c. Radar System: AN/SPS-67*

The AN/SPS-67 radar is a solid-state surface search radar that can also be used to assist in navigation. The AN/SPS-67 radar provides accurate detection and tracking for low-flying targets in a rainy and sea cluttered environment. AN/SPS-67 assists in navigation due to its ability to detect buoys and small obstructions (“AN/SPS-67,” Global Security 2012), and would assist the ship in detecting a swarm of UAVs.

*d. Identification Systems*

The DDG has the AN/UPX-29 identification system (“Arleigh Burke (Flight IIA) class,” IHS Jane’s 2012). In order to perform the identification of friend or foe function, the AN/UPX-29 interrogates unidentified targets using an electronic signal (“AN/UPX-29(V) Interrogator System,” Global Security 2012). It is assumed that AN/UPX-29 does not provide information relative to the identification of a swarm of UAVs. Therefore, the UAV identification function is included in the overall ability of the DDG to properly detect and track the air targets.

*e. Electronic Sensing System (ESS)*

The ESS provides electronic detection data to both the C&D and the Electronic Warfare System (EWS). One implementation of an ESS is the AN/SLQ-32 system (“AN/SLQ-32(V) and Surface Electronic Warfare Improvement Program (SEWIP),” IHS Jane’s 2011). The AN/SLQ-32 system is responsible for the detection, analysis, and jamming of electronic threats operating in a wide range of frequencies (“AN/SLQ-32(V) and Surface Electronic Warfare Improvement Program (SEWIP),” IHS Jane’s 2011). Earlier variants were limited to detection and analysis, while jamming capabilities were incorporated into the (V)3 and (V)5 variants (“AN/SLQ-32(V) and SEWIP,” IHS Jane’s 2011). The AN/SLQ-32(V)3 is the variant on the DDG (“Arleigh Burke (Flight IIA) class,” IHS Jane’s 2012). Although the capabilities of being able to detect, analyze, and

jam incoming electronic threats are applicable to a swarm of UAVs, AN/SLQ-32 was not designed to counter such a threat. The AN/SLQ-32 system was designed to protect the ship from Anti-Ship Cruise Missiles (ASCM) (“AN/SLQ-32 Electronic Warfare (EW) system,” Federation of American Scientists 2012). Therefore, the AN/SLQ-32 system would not provide Electronic Sensing System (ESS) capabilities for a UAV threat, as defined in the DRM, without a significant modification to the system or suffering a reduction in the system’s current capabilities.

*f. Navigation System*

While the navigation radar may assist in the detection of targets, its additional information provided would be superseded by the information gathered from the AN/SPS-67 and AN/SPY-1. It is assumed that in comparison with the AN/SPS-67 and the AN/SPY-1, the navigation radar is significantly less proficient at detecting and tracking targets.

*g. Sonar Systems*

The UAVs outlined in the DRM do not have any underwater capabilities. Therefore, sonar systems are not incorporated in the analysis of this report.

*h. EO/IR and FLIR*

The Mk 46 and MK 20 are electro-optic surveillance systems that utilize the same visual and IR sensors (“Mk 20 Electro-Optical Sensor System (EOSS),” IHS Janes 2012). These systems are used to assist the Mk 34 GWS (5” gun) in target detection (“Mk 20 Electro-Optical Sensor System (EOSS),” IHS Janes 2012). Although the (5” gun) is not considered to be applicable in the engagement of the UAV swarm, it is not unreasonable to assume that the Mk 46 and Mk 20 sensors could be used to assist other engagement systems. If it is determined that the improvement of detection systems will assist in the DDG in defending against a swarm of UAVs, then the Mk 46 and Mk 20 systems will be taken into consideration. Other electro optic and infrared sensors include the MK 48 Toplite and the Phalanx Thermal Imager. The Toplite Fire Control System assists the Mk 38

small arms mounts in target detection (BAE Systems 2011). The Phalanx Thermal Imager assists the Close-In Weapons System (CIWS) in target detection (“MK 15 Phalanx Close-In Weapons System (CIWS),” Global Security 2012). It will be assumed that detection capabilities of the Toplite Fire Control System and the Phalanx Thermal Imager will be included in the overall detection capability for these systems.

## **2. Engagement Systems**

### ***a. Electronic Warfare System (EWS)***

The EWS is a collection of systems used to counter electronic threats. The EWS uses detection, tracking, and analysis data relayed from the ESS as depicted in Figure 4. The DDG systems with electronic warfare capabilities include the AN/SLQ-32(V)3, Mk 36 Decoy Launch System (DLS), and Mk 53 – a variant of the Mk 36 DLS.

As stated previously, the AN/SLQ-32(V)3 is capable of actively jamming an electronic threat (“AN/SLQ-32(V) and Surface Electronic Warfare Improvement Program (SEWIP),” IHS Jane’s 2011). However, it is assumed that because the AN/SLQ-32(V)3 was designed to counter ASCMs and not UAVs, as defined in the DRM. Therefore, the AN/SLQ-32 system would not be able to provide jamming capabilities for the UAVs without a significant modification to the system or it suffering a reduction in the system’s current capabilities.

The Mk 36 DLS launches infrared (IR) flares and chaff countermeasures. Due to the fact that the UAVs do not have infrared seeking capabilities, IR flares are not applicable in deterring the UAVs. The purpose of using a chaff countermeasure is to reduce the effectiveness of enemy radar systems (Warren 1998). The UAVs, as defined in the DRM, do not have radar systems. Therefore, chaff is not effective in countering the UAV threat.

The Mk 53 is a variant of the Mk 36 that launches the NULKA countermeasure which is a missile decoy designed to hover at a predetermined distance from the ship in an attempt to provide an incoming missile with a more attractive target (“Nulka Active Missile Decoy System,” IHS Jane’s 2012). The NULKA provides a more attractive target by making itself appear to have a similar radar cross section to that of the ship (“MK-53

Nulka Decoy Launching System (DLS),” Federation of American Scientists 2012). Because the Harpy UAVs are guided by radar signatures and the RC UAVs are manually guided, it is believed that neither of these UAVs will be misguided by the NULKA. Therefore, it is assumed that the NULKA countermeasure will not be applicable in countering the swarm of UAVs.

***b. Gun Fire Control System***

The Gun Fire Control System, Mk 34, is a part of the MK 45 gun mount (“MK 34 Gun Weapon System (GWS),” Global Security 2012). The Mk 45 is a 5”/62 caliber gun mount implemented on the DDG platform, starting with DDG 81 (“Arleigh Burke (Flight IIA) class,” IHS Jane’s 2012). A 54 caliber version of the Mk 45 is on DDG 79 and DDG 80 (“Arleigh Burke (Flight IIA) class,” IHS Jane’s 2012). It is assumed that the minimum distance for the Mk 45 is beyond the distance from which the swarm of UAVs will be detected. Furthermore, because of the ship’s proximity to civilians, the firing of the Mk 45 would put the civilians in danger. It is for these reasons that the Gun Fire Control System is not analyzed as a counter to the UAV threats.

***c. Missile Fire Control Systems***

Systems related to the firing of anti-air missiles such as the SM-2 and SM-3 are not analyzed as counters to the UAV threats. These systems, depicted in Figure 4, include the Missile Fire Control System and the Vertical Launch System. It is assumed that the minimum engagement distance for the SM-2 and SM-3 missiles is beyond the distance at which the UAVs outlined in the DRM are detected. Other reasons not to use a missile to counter a UAV include the following. The firing of these missiles would endanger the nearby civilians and deplete the number of missiles left to defend against larger and more significant threats. Furthermore, the use of the missiles to counter the UAV threat would not be cost effective due to the high cost of the missiles and expendable nature of the UAVs.

*d. Phalanx Weapon System*

There are two Phalanx Weapon Systems, also known as the CIWS located on the DDG (“Arleigh Burke (Flight IIA) class,” IHS Jane’s 2012). The CIWS is a fast firing 20 mm gun assembly with its own fire-control radar (“Mk 15 Close-In Weapon System, Phalanx,” IHS Jane’s 2012). The system has multiple modes of operation that allow it to act as a standalone system or have a target assigned by the WCS (“The AEGIS Combat System,” Threston 2009). The CIWS has its own detection and tracking capabilities (“Mk 15 Close-In Weapon System, Phalanx,” IHS Jane’s 2012). However, because the CIWS is able to accept a target assignment from the WCS, it can accept some form of detection and tracking data provided by the SPY-1 and other detection systems. When engaging a target, the CIWS is capable of firing at about 4,500 rounds per minute and is most effective at 1.47 km (“Mk 15 Close-In Weapon System, Phalanx,” IHS Jane’s 2012). The CIWS was originally designed as a counter to anti-ship missiles, but due to its short-range firing capabilities, the CIWS would also be effective at countering the UAV threat. It is assumed that the effective range of the CIWS, 1.47 km, was determined for the primary threat, anti-ship missiles. Due to the fact that UAVs are much smaller than anti-ship missiles, the effective range for engaging UAVs is reduced in the model.

*e. Underwater Fire Control System*

The UAVs outlined in the DRM do not have any underwater capabilities. Therefore, Underwater Fire Control Systems are not incorporated in the analysis of this report.

*f. Small Arms*

Although not depicted in Figure 4, the baseline weapon systems on the DDG include four M2HB .50 machine guns and two MK-38 MOD2 machine gun systems (MGS). They are mounted on each side of the DDG.

The MK-38 MOD2 MGS is the upgraded MK-38 with a remote operation console located inside the DDG’s protected structure for crew safety during combat. The MK-38 MOD2 includes a fire control system with a forward looking infrared camera and an eye-safe laser range finder, providing target tracking and improved accuracy. The MK-38

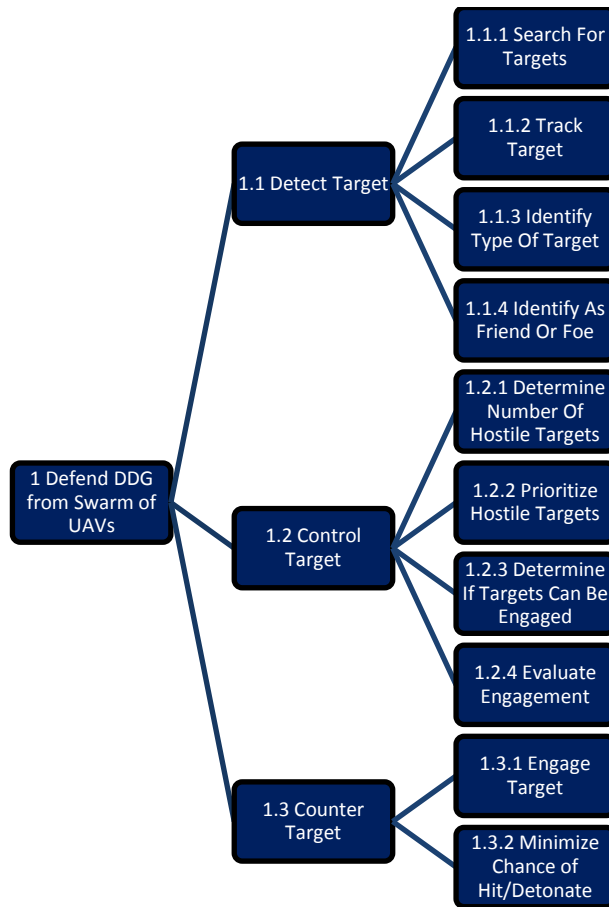
MOD2 uses 25mm ammunition with a firing rate of 180 rounds per minute (rpm) and an effective range of up to 2.5Km against aerial and surface targets larger than the UAVs described in the DRM (BAE Systems 2011). The M2HB 0.50 caliber machine gun was introduced in 1938. It has been widely used on several platforms, including the DDG. It is a crew operated machine gun with 0.50 caliber browning (12.7 x 99 mm) ammunition and a firing rate of 40 rpm with an effective range of up to 1.8 Km against aerial and surface targets larger than UAVs (Cooke, Gary' U.S Infantry Weapon Reference Guide 2010).

### **C. GAP ANALYSIS**

As defined in the DRM, the threat being analyzed in this report is a swarm of UAVs in a littoral operating environment attacking a single DDG. It is understood that a DDG is responsible for operating in various other operational environments and defending against many more threats outside of the scope of this report. Therefore, in order to ensure that the performance of the DDG is not degraded in other operational environments, it is assumed that the current capabilities of the DDG are unable to be reduced. In the section titled “AEGIS DDG Defensive Capabilities,” a high-level overview of the elements in the AWS as implemented on a DDG was given. In this section a qualitative analysis is conducted to determine if there are any limitations of the current systems in the AWS to defend against a swarm of UAVs.

#### **1. Functional Analysis**

In order for a DDG to defend against a swarm of UAVs, the functions depicted in Figure 5 need to take place. These functions were identified using a systems engineering approach. The articles titled “The AEGIS Weapon System” and “The AEGIS Combat System,” (found in the *Naval Engineers Journal* (121:3)) were used to determine the functions currently performed by the DDG in order to defend against the threats the DDG was originally designed to counter. These functions were then used to assist in the identification of the functions needed to defend against a swarm of UAVs. The resulting functions are identified in Figure 5.



**Figure 5: Functional Hierarchy – Defend DDG from Swarm of UAVs**

The functions seen in Figure 5, were intentionally identified independent of any specific system implementation.

*a. Detect Target*

As seen in Figure 5, the functions included in the detection of the target are searching for air targets, tracking the targets, eliminating clutter, and identifying if the target is a friend or foe. Searching for targets is referring to the act of physically or electronically searching the air space for targets. Once an air target is detected, the system begins to track the movement of the target. The system then uses the target’s movement characteristics to determine what type of target has been detected. It is assumed that the system has a varying degree of responses, depending on the type of target. For example, the system responds differently to an incoming missile approaching at a high speed than



an incoming UAV approaching at a low speed. In addition, it is envisioned that this function would eliminate any background clutter. Background clutter refers to the detection inputs from objects considered to be non-targets. For the purposes of this report, the function “Identify Type of Target” determines if the detected target is a UAV. Once it has been confirmed that the detected target is a UAV, the system then determines if the detected UAV is a friend or foe, which ultimately determines if the detected UAV is hostile. For a more detailed diagram that identifies the inputs, outputs, and triggers for the functions discussed in this section, see Figure C-38, located in Appendix C.

***b. Control Target***

Once a hostile UAV has been detected, the system then controls the target by performing the following functions, as seen in Figure 5: 1) determine the number of hostile targets, 2) prioritize hostile targets, 3) determine if the targets can be engaged, 4) schedule the engagement, and 5) evaluate the engagement. The system starts the controlling threat process by first determining the number of hostile targets. Once the number of hostile targets is determined, the targets are prioritized and assessed if they are able to be engaged. Targets are not engaged if the act of engaging the targets would result in damage to non-hostile targets or if the targets are inside the minimum engagement distance for all of the engagement systems. The prioritization and determination of whether or not a target can be engaged are performed primarily using the target’s location data. The basic assumption is that all of the hostile UAV targets are able to provide an equal level of damage to the ship and that hostile UAV targets that are closer to the ship are given a higher priority. After the system has determined the priority of which hostile UAVs are to be engaged, and confirmed that the hostile UAVs are able to be engaged, the system provides an engagement order that triggers the scheduling of engagements. The scheduling of engagements assigns a target to a specific engagement system as well as the temporal opportunity of engagement, or the allotted time that the engagement system has to conduct the engagement. One purpose of determining the temporal opportunity of engagement is to maximize the engagement capabilities by minimizing the duplication of effort. Knowing this information, targets can be more efficiently handed off to additional engagement systems while minimizing the chance that the target would be simultaneously

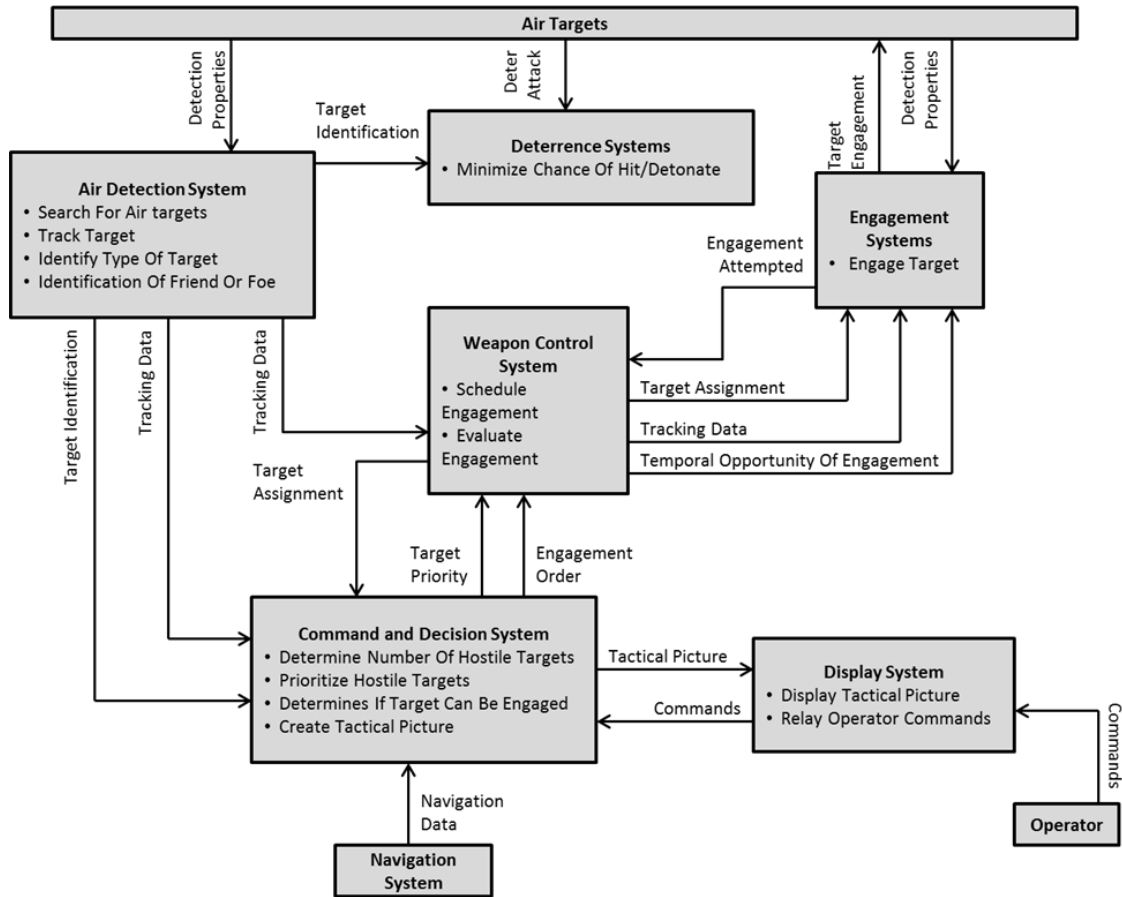
engaged by multiple engagement systems. After the engagement has commenced, the success of the engagement is evaluated until the temporal opportunity for that engagement system has expired. If the target is not successfully engaged, then the target is not destroyed. The system then includes the targets not destroyed in the total number of hostile targets for reprioritization. It is assumed that tracking data is retained throughout the entire process. For a more detailed diagram that identifies the inputs, outputs, and triggers for the functions discussed in this section, see Figure C-34, located in Appendix C.

*c. Counter Target*

The engagement of the hostile UAV is triggered by the engagement order. Once an engagement order has been received, the engagement systems wait for a target assignment and then conduct the engagement. As seen in Figure 5, the other aspect of countering the target is to minimize the chance that the target hits and or detonates near the DDG. This function refers to systems that do not need the tracking data in order to counter the target. For a more detailed diagram that identifies the inputs, outputs, and triggers for the functions discussed in this section, see Figure C-40, located in Appendix C.

**2. High Level System to Function Mapping**

In order to begin the assessment of the current AWS capabilities, an OV-2, as seen in Figure 6, was developed. The purpose of the OV-2 is to develop traceability from the needed functions to system elements. The systems shown in the OV-2 were intentionally identified independent of any specific system implementation. In the sections to follow, the high level systems identified in the OV-2 will be used to categorize the existing AWS systems and evaluate them against identified alternatives.



**Figure 6: OV-2 Defend DDG from Swarm of UAVs**

As seen in Figure 6, the Air Detection System is responsible for searching for air targets, tracking the targets, identifying the type of target, and identifying if the target is a friend or foe. The target identification is passed onto the Command and Decision System and the Deterrence Systems and the tracking data is passed onto the Command and Decision System and the Weapon Control System.

The Command and Decision System is responsible for determining the number of hostile targets, prioritizing the targets, determining if the targets can be engaged, and creating a tactical picture of the DDG's environment. The purpose of creating a tactical picture does not directly relate to the countering of UAVs, but assists in providing the elements necessary for human interaction. The Command and Decision System relays the tactical picture to the Display System, in order to be displayed. The operator interfaces with the Display System and provides the necessary commands which are relayed back to

the Command and Decision System. If included in those commands is an engagement order, the order is then relayed to the Weapon Control System. However, it may be the case that the system has been put into an automatic mode where the engagement orders are automatically generated. In this situation the engagement orders would be created from predetermined criteria, and not come directly from the operator. The operator would have to issue some form of a command to place the system in an automatic mode.

The Weapon Control System schedules the engagements by using the target's priority and distance from the ship, which is obtained from the tracking data. The result is a target assignment and temporal opportunity of engagement for a specific engagement system. In addition, the Weapon Control System relays the applicable tracking data required for engagement. The reason the tracking data is not relayed from the Air Detection System directly to the Engagement Systems is because this minimizes the number of required interfaces due to the multiple sources of tracking data. If the Air Detection Systems directly interfaced with the Engagement Systems, then there would be a need to interface multiple sources of tracking data with multiple engagement systems. On the other hand, if the tracking data is relayed through the Weapon Control System, then there would be multiple sources of tracking data interfacing with potentially one Weapon Control System. In addition, there would be potentially only one interface from the Weapon Control System to a particular engagement system. Once the Weapon Control System receives feedback from the Engagement Systems that an engagement has been attempted, the Weapon Control System evaluates the Engagement and relays the targets not destroyed to the Command and Decision System for reprioritization.

The Deterrence Systems are responsible for minimizing the chance that a target will hit and or detonate near the ship. The target identification provided by the Air Detection System is used to determine when the deterrence systems are to be activated. For passive deterrence systems, this input may not be required. The deterrence systems do not need to interface with any additional systems beyond the air detection system because it is assumed that the deterrence systems will always be activated when triggered by a threat.

### 3. AWS System Traceability

This section will explore the AWS systems applicable to countering a swarm of UAVs as discussed in the section titled “AEGIS DDG Defensive Capabilities.” Table 1 provides a mapping of the AWS systems to the systems shown in Figure 6. The AWS systems were only mapped to the high-level systems in Figure 6 if it was believed that the AWS system could perform the applicable functions.

**Table 1: AWS System Traceability Matrix**

Air Detection Systems	Command and Decision System	Display System	Weapon Control System	Deterrence System	Engagement Systems
AN/SPY-1D(V) AN/SPS-67 CIWS	C&D Mk 2	ADS Mk 2	WCS Mk 8		MK-38 (x2) M2HB (x4) CIWS (x2)

SLQ-32(V)3, as previously discussed, has electronic search and attack capabilities. However, SLQ-32(V)3 is designed for incoming missiles. The system might not be robust enough to counter UAVs without significant modifications or a reduction in its current capabilities due to the small radar cross sections flying at slow speeds. Therefore, SLQ-32(V)3 is not depicted in Table 1.

### 4. Capability Gaps

From Table 1, it can be seen that the current AWS has at least one system able to perform the functions required for each of the high-level systems except for the Deterrence System. Although it can be argued that deterrence systems are not needed if the engagement systems are capable of engaging all threats, adding deterrence systems may be an economical way to ensure the safety of the ship if the engagement systems were to be destroyed or overwhelmed. Therefore, deterrence systems should not be overlooked without some form of analysis, as they may provide another effective layer of defense. The sole reliance on engagement systems is seen as a capability gap that is investigated further in this report.

As seen in Table 1, the AWS has three primary sources of detection and tracking data: the AN/SPY-1D (V), AN/SPS-67, and CIWS systems. Although these systems are effective in the detection and tracking of air targets, the systems may not be robust enough to handle the detection and tracking of UAVs. This is due to the fact that the UAVs discussed in this report have small radar cross sections and fly at slow speeds. This report assumes that these detection systems are capable but not 100% effective at detecting, tracking, and correctly identifying the incoming UAVs. The importance of having the capability to detect, track, and correctly identify incoming UAVs with a 100% effectiveness is investigated further in this report.

As seen in Table 1, the AWS primarily has three types of engagement systems for defending against a swarm of UAVs: two MK-38 small arms mounts, four M2HB small arms mounts, and two CIWS. It is unclear how effective these three types of systems would be at countering a swarm of UAVS. The effectiveness of these systems is investigated further in this report.

THIS PAGE INTENTIONALLY LEFT BLANK

### **III. BASELINE MODELING AND SIMULATION**

From the Stakeholder Analysis discussion, the primary objective is to protect the DDG from attacks made by the swarm of UAVs. This section will investigate the current DDG's ability to defend against a swarm of UAVs and determine alternative solutions. The effectiveness of the UAV attacks is represented by the number of hits the UAVs are able to inflict upon the DDG. This section starts by describing how the team modeled the applicable systems as identified in Table 1, in order to establish a baseline performance in defending against a swarm of UAVs. Once a baseline was established, a sensitivity analysis was performed to determine which variables have the most influence on the performance of the DDG's defensive capabilities.

#### **A. METHOD**

Modeling and simulation (M&S) facilitates analysis of a UAV swarm attack on a DDG. The choice of Microsoft Excel simulation allows for a quick and easy parameter value change for proposed calculations within the model. The Monte Carlo approach was the method chosen because it allows the model output to simulate and analyze the random variables in the DRM (Blanchard and Fabrycky 2011). The two primary goals for the baseline model are to characterize the capabilities the baseline DDG brings to bear during an attack from a swarm of UAVs and to identify gaps that can potentially be mitigated through enhancements to the DDG.

The baseline model reflects an operational environment based on the defined user need addressed in the DRM. The team analyzed and researched the current capabilities the DDG has to defend against a UAV swarm attack. The identified information establishes input placeholder values for the baseline model. In order to keep this baseline model UNCLASSIFIED, the remainders of the parameters are based on accessible unclassified data and assumptions for the unknowns. The identified parameters are not a limitation for actual "real world" results, as these placeholder values are capable of being interchanged.



## B. MODEL BLOCK DIAGRAM

The baseline model consists of three layers of defenses capable of withstanding a UAV swarm attack. Each of the three layers in the baseline model includes opportunities for detection and opportunities for engagement by defensive weapon systems. With the given scenario, the number of UAVs in the swarm ranges from five to ten, with a baseline number of eight to be used for the model results. The ‘CRITBINOM’ is the primary function that is implemented in the model equation to return a cumulative binomial distribution. This function is executed by “returning the smallest value for which the cumulative binomial distribution is greater than or equal to a criterion value” (Microsoft Support 2007). Inserting a random number into the function allows for a new calculation each time the function is called, resulting in different possible outcomes for each simulation run. The tables below describe the identified values for the model baseline.

**Table 2: Sensor Detection Parameters**

Sensor Detection Layer	Effective Range (m)	Probability of Detection
Long	1000	.4
Medium	500	.5
Short	250	.6

**Table 3: CIWS Parameters**

CIWS Engagement Layer	Effective Range (m)	Probability of Kill	Firing Cycles (s)
Long	750 to 500	.2	1.25
Medium	500 to 250	.3	1.25

**Table 4: Small Arms Parameters**

Small Arms Engagement Layer	Effective Range (m)	Probability of Kill	Firing Cycles (s)
Medium	500 to 250	.1	.6
Short	250 to 0	.15	.6

**Table 5: UAV Parameters**

UAV Swarm Type	UAV Speed (m/s)	Probability of Hit
Harpy	69.44	.9
Radio Control (RC)	69.44	.9

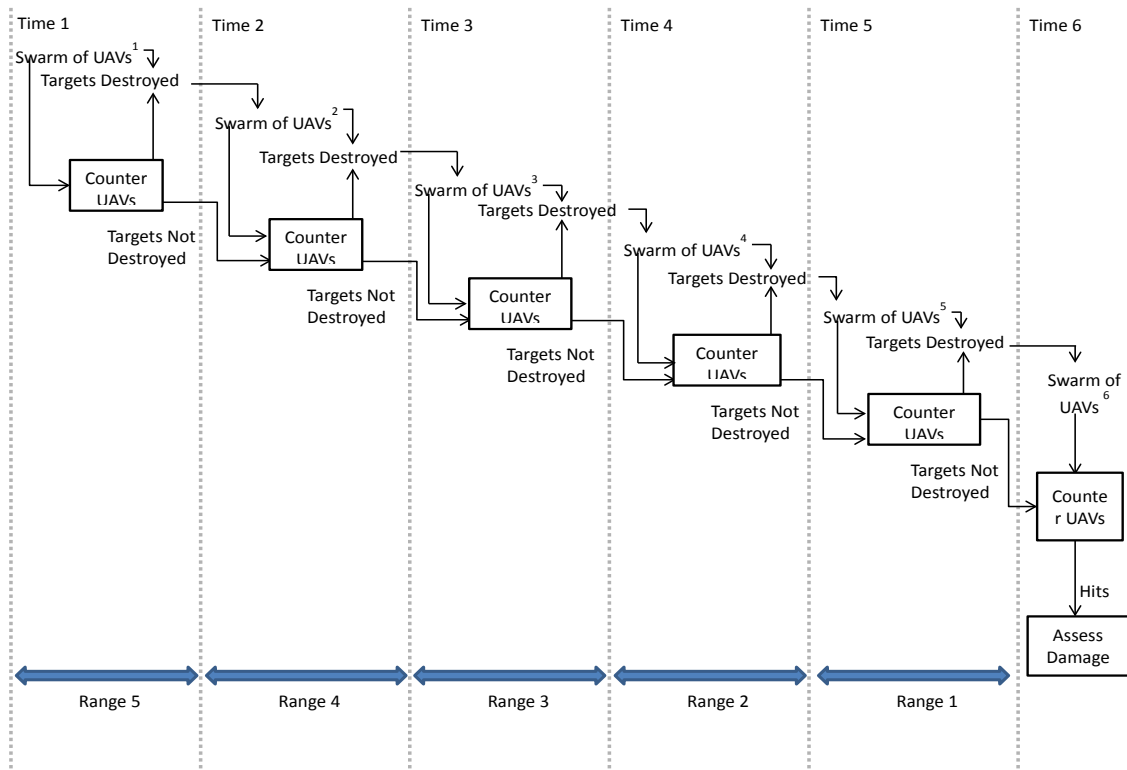
The baseline model has a sequence that flows from each of these three layers during a UAV swarm attack. A fixed number of incoming UAVs has been set to four Harpy UAVs and four RC UAVs. In the baseline model, the incoming swarm UAV will enter the first layer of defenses. The long-range sensors have a chance to detect each member of the UAV swarm with the probability defined in Table 2. The leaked (undetected) UAVs are calculated from the initial amount of UAVs subtracted from the detected number of UAVs. The defensive weapons are assumed to spend a certain amount of time on each target. This “cycle time” includes the time required to acquire a target, fire at it, conduct battle damage assessment, and move to the next target (if necessary). For every cycle spent on a target, there is a probability of kill dependent on the range as defined in Table 3 and Table 4. The number of defeated UAVs also depends on the number of detected UAVs; the defensive weapon systems cannot defeat more UAVs than have been detected so far. Table 6 follows an example swarm of UAVs through each layer of the baseline model.

**Table 6: Baseline Model Sequence of Events Example**

	Remaining UAVs	Detected UAVs	Undetected UAVs	Defensive Weapon Systems	Defeated UAVs
Long Range	8	3	$8 - 3 = 5$	CIWS	0
Medium Range	8	2	$5 - 2 = 3$	CIWS, Small Arms	2
Short Range	6	3	$3 - 3 = 0$	Small Arms	1
Total	5	8	N/A	N/A	3

Eight inbound UAVs enter the long range layer where three UAVs are detected. Given that three have been detected, five are leaked through the long range layer. The defensive weapon systems did not defeat any UAV at the long range layer. At the medium range layer, two UAVs have been detected out of the five that were leaked from the

long range layer. Given that two have been detected, three have been leaked through the medium range layer. The defensive weapon systems defeated two UAVs at the medium range layer. Finally, the short range layer detects three UAVs that were leaked from the medium range layer. Given that three have been detected, none were leaked. The defensive weapon systems defeated one UAV at the short range layer. From Table 6, there are a total of three UAVs that have been defeated by the defensive weapon systems and five remaining UAVs which each have a probability of hitting the destroyer as defined in Table 5. A model block diagram in Figure 7 shows the series of events in a UAV swarm attack.



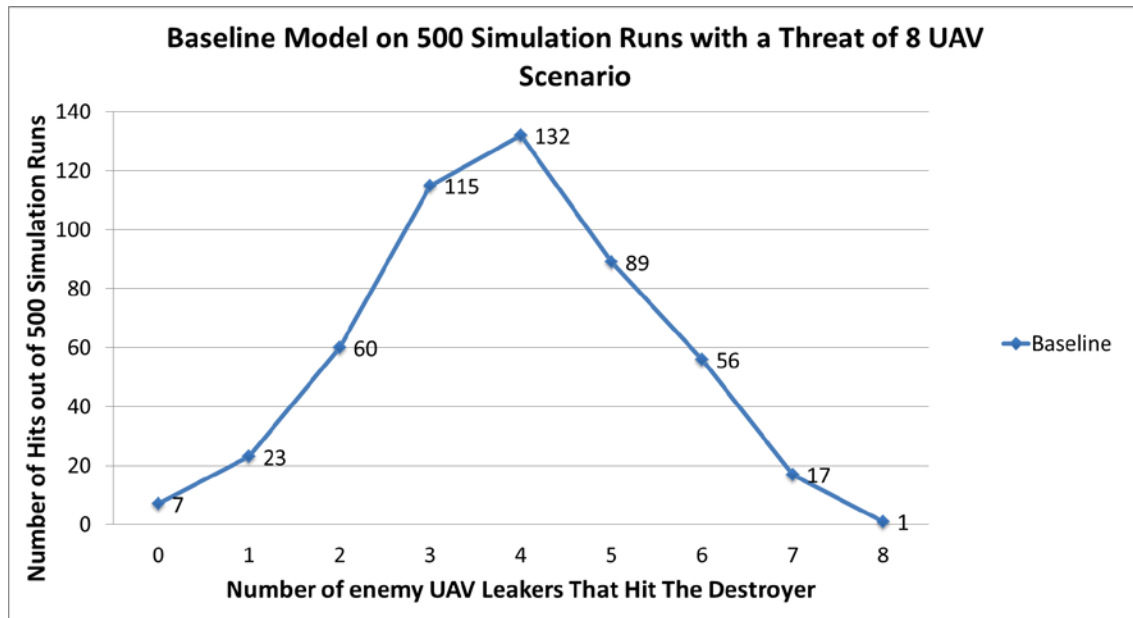
**Figure 7: Model Block Diagram**

The primary sense of this model is to reiterate the sequence of events that were explained through the previous example, but in a descriptive block diagram. The diagram intentionally depicts each “Counter UAVs” at a given range closer to the bottom of the diagram than the “Counter UAVs” at the previous range. This symbolizes that with each succession, the threat becomes closer to the ship. The swarm of UAVs will continue to

flow down and hit the destroyer unless they are completely destroyed through the counter-UAV tactics such as CIWS and small arms. The baseline model only makes use of the middle three ranges and times, but leaves room for proposed system alternatives to make use of additional ranges and times.

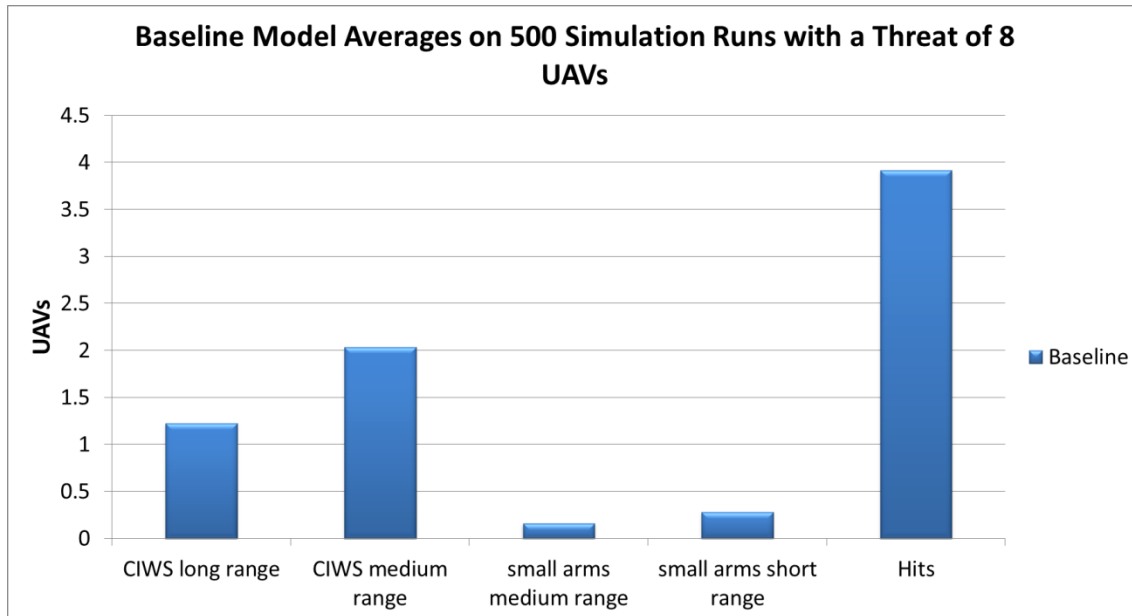
### C. BASELINE MODEL RESULTS

The baseline model results have valuable information that can lead the team to explore for better enhancements. Figure 8 shows 500 simulation results for a swarm of 8 UAVs attacking a DDG. The baseline DDG would experience a significant amount of UAV hits; the most likely outcome is for four UAVs to impact the ship.



**Figure 8: Baseline Model: 500 Simulation Runs with 8 Inbound UAVs**

Additional baseline model results in Figure 9 include the average number of UAVs destroyed by each defensive weapon system at each range.



**Figure 9: Baseline Model Averages for 500 Simulation Runs with 8 Inbound UAVs**

## D. SENSITIVITY ANALYSIS

With the model in place for the baseline DDG, a sensitivity analysis showed which types of improvements yielded the greatest effect on the model’s outcome. The sensitivity analysis involved varying several input parameters individually and comparing how each affected the number of hits scored by UAVs, so that system alternatives could focus on improving the most important parameters.

### 1. Method

The sensitivity analysis included two levels of improvements to these parameters: small arms accuracy, CIWS accuracy, small arms cycle time, CIWS cycle time, and detection accuracy. From the baseline model, the probability-based accuracy parameters increased by 0.1 and 0.2, while the time-based parameters decreased by 0.1 and 0.2 seconds. Improving one parameter at a time allowed the team to compare each simulation’s average number of hits scored on the DDG.

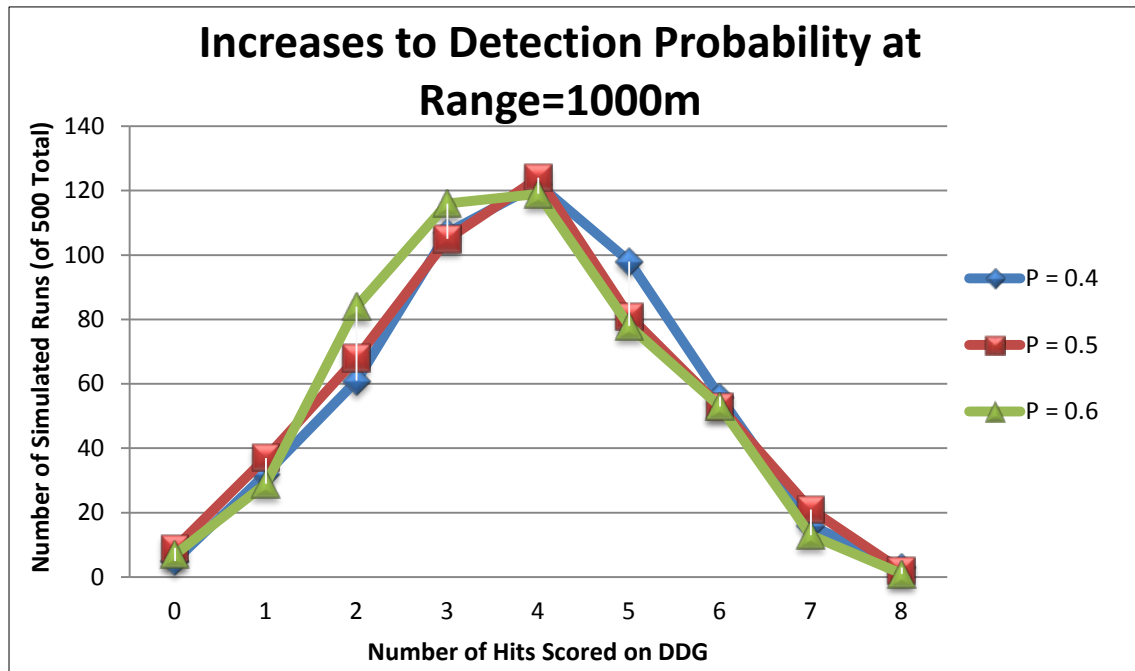
Weapon system range did not play a part in the sensitivity analysis, because decreasing cycle time yields the same result. For a given accuracy, a weapon system can

shoot down a number of targets dependent on how much time the targets spend within range, and how much time the system spends on each target. So, decreasing the cycle time would have the same effect as increasing the range; the weapon system would have the opportunity to shoot down more targets. When the model shows improvement with cycle time decrease, the DDG improvements which correspond to the results would include improvements to weapon system range.

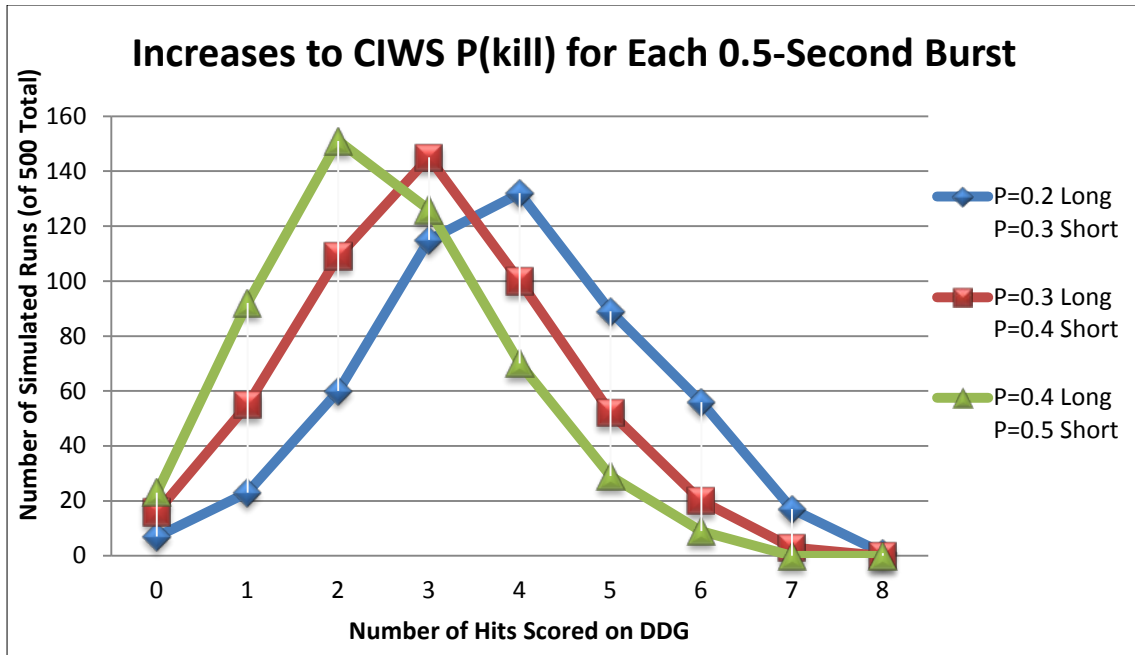
The team also experimented with other changes to gain insight into the model behavior. This included changing the number of UAVs in the inbound swarm from eight down to five and up to ten. It also included improving the weapon system parameters with an accuracy increase of up to 0.5 and a cycle time decrease of up to 0.45 seconds.

## 2. Results/Discussion

Improving sensor accuracy did not have much impact on the number of hits scored by the eight inbound UAVs as shown in Figure 10, whereas improving weapon system parameters, such as the CIWS accuracy in Figure 11, had more of an impact.

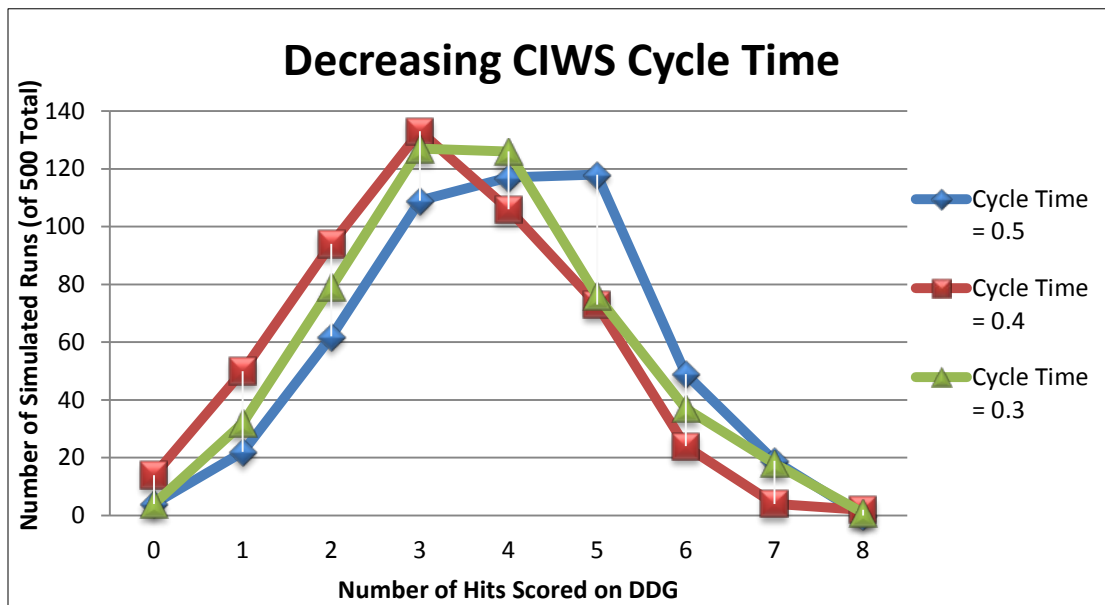


**Figure 10: Model results for increase to detection**



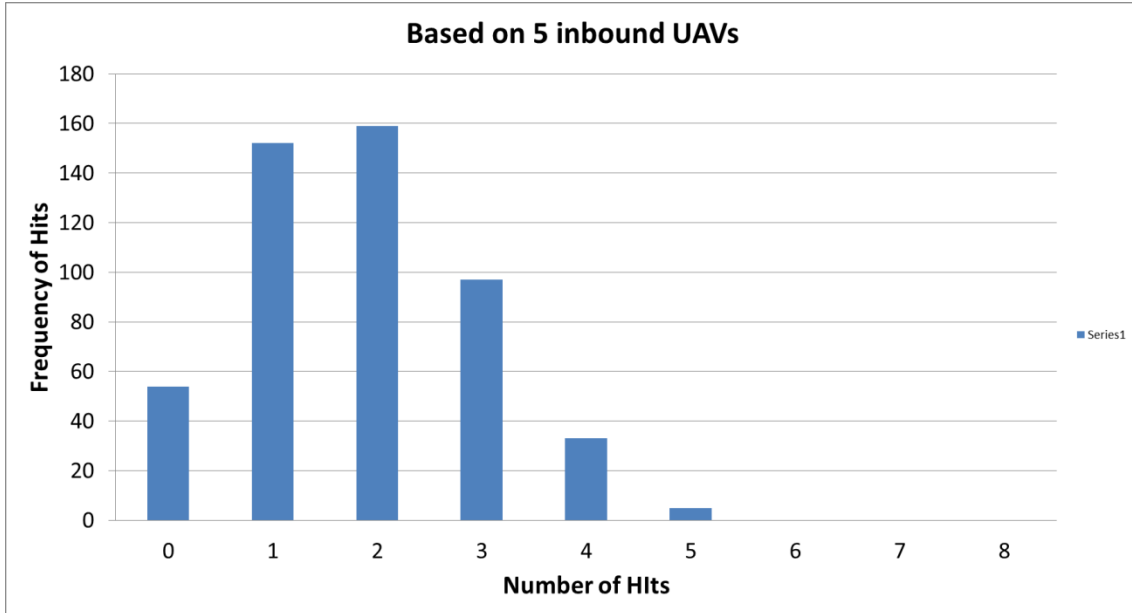
**Figure 11: Model results for increase to CIWS accuracy**

Improvements to the CIWS accuracy and cycle time both reduced the number of hits, with comparable increases to accuracy (Figure 11) making more of a difference than decreases in cycle time (Figure 12).

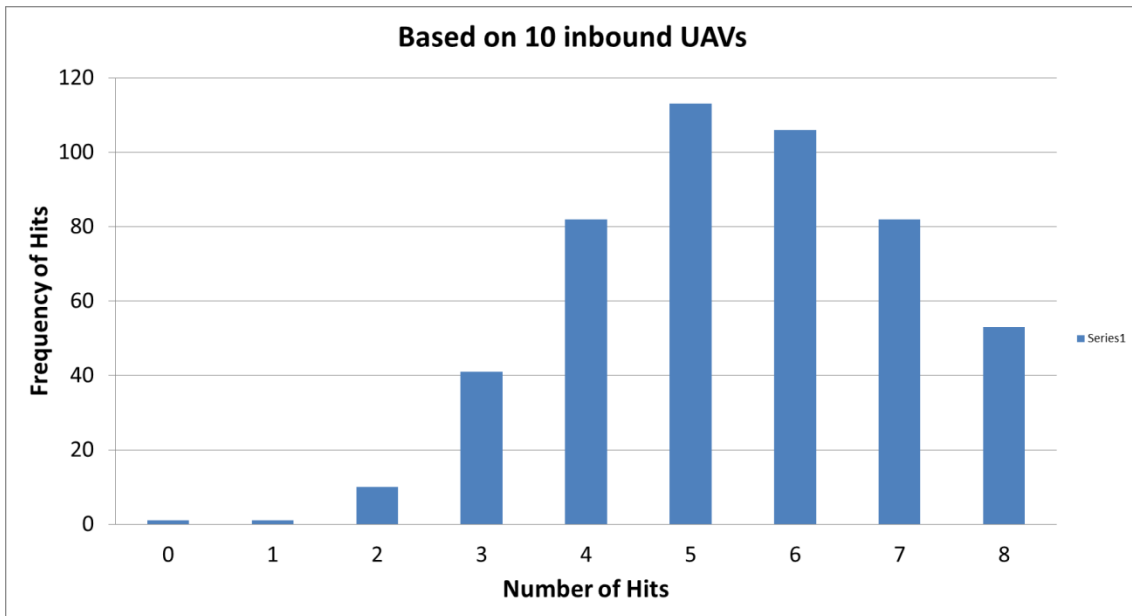


**Figure 12: Model results for decrease to CIWS cycle time**

Reducing the number of incoming UAVs to 5 allowed the DDG to withstand it more easily (Figure 13), while 10 UAVs easily overwhelmed the baseline DDG's defenses (Figure 14).



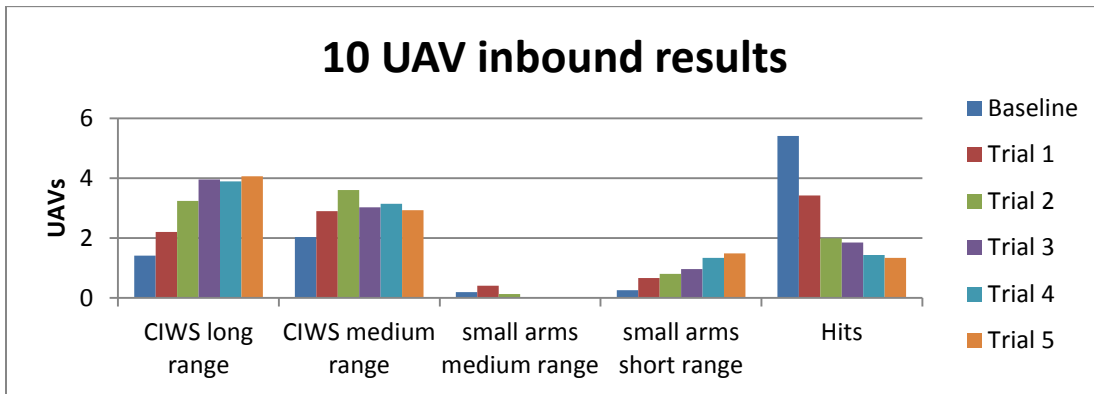
**Figure 13: Baseline DDG with 5 inbound UAVs**



**Figure 14: Baseline DDG with 10 inbound UAVs**



Successive improvements to the CIWS and small arms made diminishing returns on the number of hits reduced. With 10 incoming UAVs, Figure 15 shows a number of trials which increase accuracy by 0.1 above the previous trial, ranging from an improvement above the baseline of 0.1 in Trial 1 to 0.5 above the baseline in Trial 5. Cycle time similarly decreased below the baseline from 0.09s in Trial 1 to a decrease of 0.45s in Trial 5. These changes drastically altered each weapon system's parameters; the CIWS at long range, for example, went from a baseline accuracy of 0.2 and cycle time of 0.5s to a Trial 5 accuracy of 0.7 and cycle time of 0.05s. This tenfold increase to the number of targets the CIWS can engage does not correspond to any potential DDG improvement, but rather helps to show interesting model behavior.



**Figure 15: Successive weapon system improvements**

Drastic weapon system improvements reduce the number of hits scored on the DDG, but only to a point, as shown by the right-hand graph in Figure 15. Whereas Trial 1 reduces the average hits scored to 3.4 from a baseline of 5.4, and Trial 2 reduces them to 2.0, Trial 5 only further reduces the hits to 1.3. Because sensors did not improve along with the weapon systems, some UAVs remain undetected until they impact the ship.

The first four graphs of Figure 15 show how many UAVs are shot down by the two weapon systems at each range. As the CIWS parameters improve, at long range it improves from shooting down a baseline of 1.4 UAVs to 4.0 UAVs in Trial 3. Performance does not improve beyond that because the CIWS has exhausted all available targets, which are the UAVs detected at long range. The CIWS performance similarly im-

proves at medium range, increasing from a baseline of 2.0 to 3.6 in Trial 2. After Trial 2, so many UAVs are shot down at long range that there are fewer available targets at medium range, so even with continuing improvement, the CIWS shoots down fewer targets at medium range.

A similar decrease in performance affects the improved small arms at medium range. The number of UAVs shot down increases from a baseline of 0.2 to 0.4 in Trial 1, but then decreases to 0.1 in Trial 2 and to 0 after that. The CIWS in Trial 3 and beyond is so effective that it leaves zero UAV targets available for the small arms at medium range. At short range, the small arms performance steadily increases from a baseline of 0.3 UAVs shot down to 1.5 in Trial 5. Continuing to improve small arms does make a difference at short range, because there are some UAVs which evade detection until they reach short range. In Trial 3 and afterward, all targets detected at long or medium ranges are destroyed by the CIWS. When newly detected targets become available at short range, they are inside the CIWS minimum engagement range, leaving the small arms as the only engagement option.

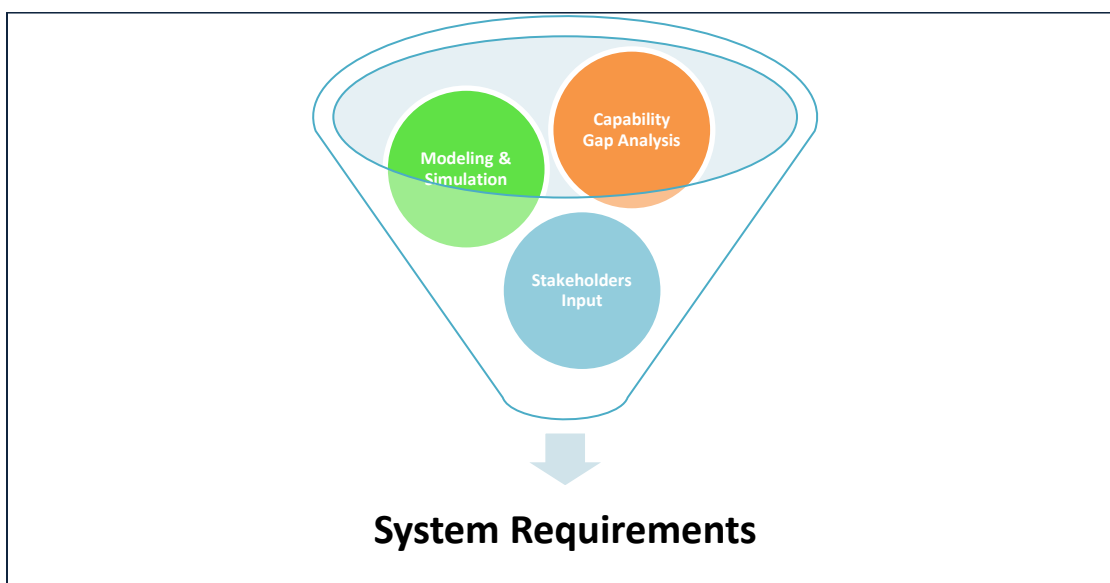
### **3. Conclusions**

Improving the sensors is not as effective as making weapon system improvements, and weapon systems would have to be improved a significant amount before the improvements' effectiveness becomes limited due to the sensors. Therefore, the system alternatives focus on neutralizing, not detecting, UAVs.

THIS PAGE INTENTIONALLY LEFT BLANK

## IV. REQUIREMENTS ANALYSIS

This section establishes the system requirements using capability gap analysis, baseline modeling and simulation, and stakeholder analysis. Requirements definition at the early stages of the systems engineering process is vital to develop system solutions capable of solving a particular problem, since requirements drive the quality, functionality and effectiveness of the system. Requirements provide tangible statements of needs that engineers can focus on meeting. Sharon Vannucci, based on several years of experience in the systems engineering field, defined system requirements as “characteristics that identify the accomplishment levels needed to achieve specific objectives under a given set of conditions.” Further, she says that requirements should define “what the system is supposed to do but not specify how the system is to perform” (Vannucci 2010).



**Figure 16: System Requirement identification sources**

Team Crane developed a requirement list based on three main sources as shown in Figure 16: (1) capability gap analysis, (2) modeling and simulation, and (3) stakeholders. As described in the capability gap analysis section, several technical capabilities gaps and/or deficiencies were found in the DDG defenses against UAV swarm attacks such as:

- Lack of deterrence systems, in the case that the engagement systems are not capable of engaging all threats
- Sole reliance on engagement systems
- Limited detection and tracking capabilities in the detection of air targets with a small radar cross section area
- Limited detection and tracking capabilities in the detection of air targets flying at lower speeds
- Limited capability to identify UAVs
- Limited electronic attack capability to defeat a UAV swarm attack

Gaps in technical capabilities were translated into functional requirements (Appendix D – System Requirements), as a response to the deficiencies found in the studied areas. M&S was used to illustrate the DDG baseline capabilities to withstand an attack from a swarm of UAVs. M&S through Microsoft Excel allowed the exposure of the system to a variety of possible operational scenarios in a short period of time without risking the system, enabling money and time to be saved. The baseline DDG model allowed the engineers to observe and gather technical data on the DDG's effectiveness against different scenarios and threats. After analyzing the findings of the capability gap section, Team Crane came up with a series of improvements to the DDG to close current and future gaps. In the late stages of M&S, the DDG baseline was modified and tested with different combinations of the proposed improvement alternatives to the DDG such as the EW capability and smokescreen alternatives.

In the modeling and simulation section are listed the results of hundreds of runs of the baseline system, which revealed the DDG's inability to defeat a UAV swarm attack. The baseline and modified baseline model results provided useful information which led to the requirements in Appendix D.

Stakeholder input was vital to define some of the requirements that shaped the arranged set of solutions presented in the following sections. Stakeholder input was gathered through meetings and other communication such as e-mail and telephone conversation. Requirements reflect stakeholders' needs, which led to enhanced solutions, and ultimately a better system.

After developing the requirements for the DDG, requirements were linked to the system functions using CORE 8 from Vitech. CORE 8 is a comprehensive modeling environment built for complex systems engineering problems. It provides “a flexible way to visualize the interactions between requirements, functions, and components” (Vitech n.d.). Appendix D shows the functions linked to the requirements. CORE 8 provides clarity and allows the recipient to understand how requirements and system functions are connected.

Several alternatives/systems solutions to the requirements needs are discussed in the following sections. During the risk assessment analysis, an evaluation of the effect of the proposed alternatives and the risk that it poses to the requirements was done. It provides a clear assessment of the alternative implementation risks.

THIS PAGE INTENTIONALLY LEFT BLANK

## V. SYSTEM ALTERNATIVES

With regards to the DDG's baseline performance, the results of the sensitivity analysis established that the improvement of engagement systems was more effective than the improvement of detection systems. In this section, engagement alternatives are identified and assessed based on cost and risk.

### A. METHOD

#### 1. Generation of Alternatives

After performing the sensitivity analysis on the baseline model, the team brainstormed possible alternatives to decrease the number of UAV hits on the DDG. As previously discussed, detection alternatives were not taken into consideration. This is because it was concluded from the sensitivity analysis that increasing the engagement capabilities of the DDG had a much greater effect than increasing detection capabilities. Open discussion generated many possible alternatives which the team then narrowed based on the sensitivity analysis results, and alternatives which only improve detection were excluded. The team selected all but the most infeasible remaining alternatives, and noted for each rough estimates of the applicable threat, model impact, and risk associated with implementation as described in Table 7.

**Table 7: Alternative Methods**

Alternatives	Applicable Threat	Model Impact	Risk
LAWS	Harpy/RC	Medium	Low
(EW) RC Jamming (360 degree coverage)	RC	High	Medium
UAV acting as Radar Decoy	Harpy	High	Medium
Fire Scout with Conventional Weapons	Harpy (Possibly RC)	Low	Low
Additional Small Arms	Harpy/RC	Low	Low
Ship Radar Decoy	Harpy	High	Medium
Reactive Armor	Harpy/RC	Medium	Medium
Fog/Smoke Screen	RC	Medium	Medium
Shrapnel-Chaff	Harpy/RC	Medium	High
Additional CIWS	Harpy/RC	Medium	Low



The applicable threats were assigned for each of the ten alternatives. Some of the selected alternatives have the potential to engage both threats, which is superior to alternatives capable of engaging only one UAV type. The model impact was rated from low to high for each alternative based on the team’s estimate. For instance, the team believed that the electronic warfare (EW) option to jam RC UAVs would have a better impact in the model than adding additional small arms mounts. A rough estimate of risk is also associated with each alternative based on implementing the design on the DDG.

## 2. Method for Cost Estimation of Alternatives

The cost estimation process for each alternative involves using a framework for total ownership cost analysis. All cost estimates for this project exclude the cost of inflation; therefore, all final cost estimates are valued in the year of the budget material used as a reference. The cost estimation framework is established with five columns for tasks, reference cost, percentage of effort, duration of effort, and alternative cost estimate for each alternative as shown in Table 8.

**Table 8: Cost Estimation Framework**

Tasks	Reference Cost (\$M)	Percentage of Effort vs. Reference Cost (%)	Duration of Effort (Years)	Alternative Cost Estimate (\$M)
System Development	\$ Value	%	Number of Years	=\$Value*%*Number of Years
System Test and Evaluation	\$ Value	%	Number of Years	=\$Value*%*Number of Years
System Management	\$ Value	%	Number of Years	=\$Value*%*Number of Years
System Procurement	\$ Value	%	5	=\$Value*%*5 OR \$Value*Qty
System Sustainment	\$ Value	%	12	=\$Value*%*12
<b>Total =</b>				Sum of Estimation per task

The first column contains the major tasks for a program from the start to the end of the life cycle. The major tasks are identified in the system engineering process as 1) system development, 2) system test and evaluation, 3) system management, 4) system procurement, and 5) system sustainment.

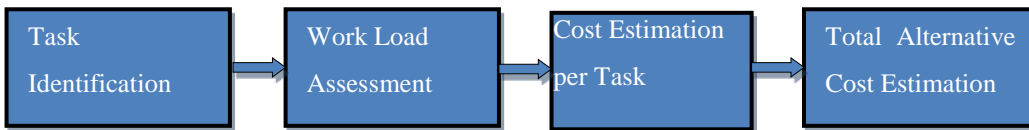
The second column is the reference cost. The reference cost estimates are associated with each major task. The reference cost estimates can be from the Navy budget for a similar Navy project, a similar work project, or a commercial off the shelf vendor.

The third column is the percentage of effort for each task compared to the reference cost in Column Two. The percentage of effort for each task is weighted according to the results of the alternative work load analysis. The percentage of effort can be in between 0% and 100% or greater than 100%, in the case where the effort is more than the reference cost.

The fourth column is the duration of effort for each task. The duration of effort is weighted according to the results from the work load analysis for each task. The duration of effort is assumed to be 12 years for the alternative life cycle after the system development and test and evaluation tasks are completed. The duration for the system management is the sum of duration of system development, system test and evaluation and 12 year system life cycle. The duration for system procurement assumes that the procurement funding allocation is equally distributed for the 5 year installation period.

The fifth column is the alternative cost estimate for each task. The alternative cost estimate for each task is the product of Columns Two, Three and Four. The system procurement cost estimate can also be estimated from the cost per system and quantity required; in this case, the 5-year duration does not contribute to the line item total. The total cost estimate of the alternative is the sum of the alternative cost estimates for each task.

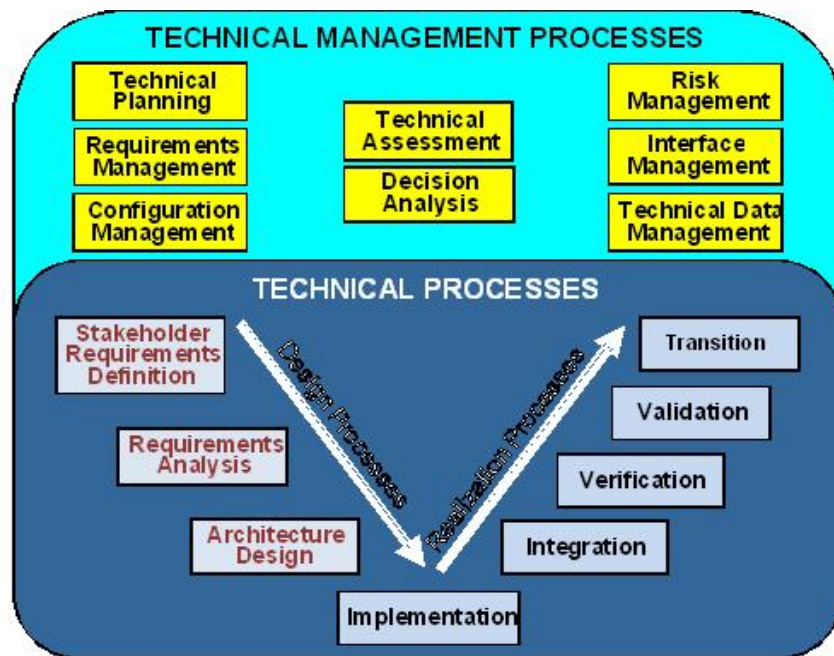
With the framework defined, the cost estimation process includes task identification, work load assessment, cost estimation per task, and total alternative cost estimation as shown in Figure 17.



**Figure 17: Cost Estimation Process**

a. *Alternatives Task Identification*

Tasks identification is the assessment of the required tasks to implement the alternatives. The alternative can be a newly designed system implementation. Or, the alternative can be just a modification of the existing systems or just an additional quantity of existing systems, such as extra small arms mounts or CIWS mounts. The tasks identification is done according to the tasks categories as shown in Table 8 and in line with the Department of Defense (DoD) systems engineering process as shown in Figure 18.



**Figure 18: 2009 DoD Systems Engineering Process Model  
(From Defense Acquisition University)**

System development provides services derived from the analysis of users' needs as well as the threat environment, to development of the system requirements, the design and the integration of the system hardware and software (which perform the desired functions), and the system prototype development for test and evaluation.

System test and evaluation includes developmental test and evaluation of the system prototype and operational test and evaluation of the delivered systems.

Program management provides the services such as resource allocation, personnel management, contracts oversight, risk management, technical interface management,

technical data management, and configuration management, which are identified in the DoD system engineering process shown in Figure 18. Program management also provides the government engineering services, subject matter experts, and travel costs such as per diem, transportation, and miscellaneous costs.

System procurement includes the acquisition services to procure the systems as well as to allocate the funding to purchase the systems for the fleet, including shipping and handling services. System sustainment provides services to sustain the system during its life cycle, such as integrated logistics support, government engineering support, and system disposal/demilitarization. Integrated logistics support provides the services for the systems maintenance, the users' training, the systems problem tracking, and all other logistics to sustain the systems. Government engineering support provides the technical services for system maintenance and the systems subject matter expertise to install the systems and to sustain the systems until the end of the life cycle.

***b. Alternatives Work Load Assessment***

Work load assessment is the estimation of the required efforts and duration of the efforts for each task for the systems life cycle which are discussed in the task identification section. The estimation is performed based on the work load relatively scaled in reference to the similar existing programs. The 0% end of the effort scale represents the estimation that no effort is needed in reference to the similar existing program, while 100% represents the estimation that the same amount of effort is needed in reference to the similar existing program. However, the percentage of effort can be more than 100% if the magnitude of the effort for that task is greater than what is indicated in the reference cost. The duration of the cost estimation for the life cycle of the alternative systems is based on the magnitude of the alternative, with 5 years for most procurement and installation efforts, and 12 years for sustainment. However, it cannot go beyond the DDG life cycle.

***c. Alternatives Cost Estimation***

Cost estimation is the next step in the process. It is based on the reference cost and the results from the task identification and work load assessment. The cost estimation is calculated as the product of the reference cost, the percentage of effort, and the dura-

tion of effort. The total alternative cost estimation is the sum of the costs from the individual tasks. Table 9 is the cost estimation for the small arms mounts alternative as an example of how the cost estimation is achieved, and it is discussed in the section of this report titled “Small Arms Mounts Alternative.”

**Table 9: Cost Estimation for Small Arms Mounts Alternative**

<b>Tasks</b>	<b>Reference Cost (\$M)</b>	<b>Quantity</b>	<b>Percentage of Effort vs. Reference Cost</b>	<b>Duration of Effort (Year)</b>	<b>Alternative Cost Estimate (\$M)</b>
<b>SYSTEM DEVELOPMENT</b>	\$0.00	1	100%	0	\$0.00
<b>SYSTEM TEST &amp; EVALUATION</b> (Research, Development, Test and Evaluation, Navy 2012)	\$1.00	1	25%	5	\$1.25
<b>SYSTEM MANAGEMENT</b> (Research, Development, Test and Evaluation, Navy 2012)	\$1.20	1	60%	12	\$8.64
<b>SYSTEM PROCUREMENT</b>					\$251.10
MK 38 MOD2 Procurement (Weapons Procurement, Navy 2012)	\$1.13	124	100%	5	\$139.62
MK 38 MOD2 Installation (Weapons Procurement, Navy 2012)	\$0.56	124	100%	5	\$69.94
M2HB 50 Cal (Weapons Procurement, Navy 2012)	\$0.01	62	100%	5	\$4.34
CROWS II (Army Guide 2008)	\$0.08	310	100%	5	\$24.80
M2HB 50 CROW II Installation (Estimation=50% cost of procurement cost)	\$0.04	310	100%	5	\$12.40
<b>SYSTEM SUSTAINMENT</b> (Operation and Maintenance, Navy 2012)	\$28.00	1	30%	12	\$100.80
<b>Total =</b>					\$361.79

### 3. Method for Risk Assessment of Alternatives

The team assessed risk for each individual alternative. The number of risks that need to be looked at for each alternative depended on what requirements applied to each specific alternative. Every alternative is designed to improve the DDG’s chances of defeating a suicidal UAV threat, so the requirements of that alternative must map to a specific risk. For each alternative, the team considered what obstacles could prevent that alternative from being implemented on the DDG, as well as what could prevent it from performing its full intended purpose successfully. The risk assessment process was adapted from the Navy’s Risk Management Guide for DoD Acquisition (Defense 2006). Risk was also assessed for the Technology Readiness Level (TRL) ((ASD(R&E)) 2011) of the alternative. Table E-45 can be used to determine what the TRL is based on the descriptions. Finally, any suitability considerations such as human factors, logistics, and personnel requirements that apply for a specific alternative were also taken into account as risk candidates.

For each alternative, a risk table was filled in for all of the risks that applied. Each risk was explained as to why it was a risk for that alternative. The risks were then mapped using the two tables. Table 10 was used to show the likelihood and severity of the risk and Table 11 was used to map the risks to the risk number. The order of the risks goes from highest risk to lowest risk, with 1 being the highest. The risks not associated with requirements, such as the TRL and suitability considerations, were also included in the tables. The risks are put into three categories: critical, moderate, and negligible. This gives an idea of how significant each risk is. Table 10 provides an example of how each of the tables was filled in.

**Table 10: Risk Assessment (After Defense 2006)**

<b>Risk Assessment</b>	Not Likely	Low Likelihood	Likely	Highly Likely	Near Certainty
Severe				3	1
High		7	5		2
Medium		8	6	4	
Low	11	9			
Minimal/None	12	10			
<b>Note: Red – Critical, Yellow – Moderate, Green – Negligible</b> See Table 11 for risk number mapping					

**Table 11: Risk Mapping**

<b>Risk Number</b>	<b>Risk Significance</b>	<b>Risks</b>
1	Critical	Biggest Risk
2	Critical	Risk 2
3	Critical	Risk 3
4	Moderate	Risk 4
5	Moderate	Risk 5
6	Moderate	Risk 6
7	Moderate	Risk 7
8	Negligible	Risk 8
9	Negligible	Risk 9
10	Negligible	Risk 10
11	Negligible	Risk 11
12	Negligible	Lowest Risk

**B. FIRE SCOUT WITH UAV RADAR DECOY**

Radar decoys launched from the DDG’s UAV could reduce the number of Harpy UAVs that target the DDG. The Generic Expendable (GEN-X) is a countermeasure device housed in a cartridge, and GEN-Xs are meant to be dispensed from aircraft. Such items are dispensed from aircraft countermeasure dispensers, and each cartridge can be used once. After launch, it emits a radar signals in the hopes of seducing incoming radar-guided missiles. Raytheon completed this development of GEN-X in the late 1980s, and it has been in operation since then. GEN-X is 15 cm in length (17 cm length with fin extended), 36 cm in diameter, and weighs 0.45 kg with cartridge. Raytheon Network Centric Systems from McKinney, Texas is the contractor of GEN-X decoy (Jane's Radar And Electronic Warfare Systems 2007).



**Figure 19: ALE-55, RT-1489 GEN-X (From Electronic Decoy 2011)**

The UAV radar decoy alternative would extend the capability to defend the DDG against UAV swarm attacks by launching the decoys with a dispenser such as the ALE-47. The ALE-47 can integrate with an aircraft's radar warning receivers, missile warning receivers and other electronic warfare sensors. The ALE-47 has the capability to launch radio frequency and infrared countermeasures automatically when the aircraft's sensors detect a threat to defeat incoming missiles. The ALE is compatible with a variety of countermeasures, such as different types of flares and chaff, as well as is designed to work with advanced future countermeasures. The UAV radar decoy alternative would improve the DDG protection against UAV swarm attacks at long range, because the UAV could launch the decoys before the Harpy UAVs get too close to the DDG. The implementation of this alternative would decrease the number of UAV hits (ALE-47 2008).

This alternative involves installing the ALE-47 on the Fire Scout, so that it can dispense GEN-X cartridges. The Fire Scout UAV would detect ahead of the DDG during the approach to port. When enemy UAVs are detected, the Fire Scout would move to intercept and launch the GEN-X radar decoys. The enemy Harpy UAVs would detect the radar signature of the decoy and attack it instead of the DDG. The ALE-47 consists of the cockpit control unit, sequencer units, countermeasure dispensers and an optional programmer. The cockpit control unit normally provides an interface with the pilot in the cockpit, but because the Fire Scout is piloted remotely, it would have to be modified to be controlled by the Fire Scout operator on the DDG. The sequencer units control the dis-



dispensers, and are automatically capable of detecting misfires and correcting them. The sequencers are built in to the dispenser units on the rotary-wing version. Each dispenser can hold five different types of countermeasures, for a total of 30. The whole system can accommodate up to 32 dispensers on fixed-wing aircraft and 16 on rotary-wing aircraft. Because the Fire Scout is smaller than other rotary-wing aircraft, this alternative assumes it would be appropriate to fit no more than 10 dispensers on this Fire Scout platform (ALE-47 2008).



**Figure 20: ALE-47 Dispensers and associated equipment (From ALE-47 2010)**

There are risks associated with the implementation of the UAV radar decoy alternative. The ALE-47 has been developed, tested, integrated, and fielded. The team assesses the technology readiness of this alternative at TRL 6. The technology already exists, but has not been integrated into the Fire Scout yet. Table 13 lists the risks associated with UAV radar decoy implementation. It lists from most important to least important. Accuracy is important because the radar decoys must have a high probability of seducing the Harpy UAV threat. Range plays an important part as well, in that the decoys might not be successful if they cannot attract the Harpy UAVs from a large enough distance. Next is

availability, because dispensers from the decoy need to be available on time when in operation.

**Table 12: Fire Scout with UAV Radar Decoy Alternative Risk Assessment**

Risk Assessment	Not Likely	Low Likelihood	Likely	Highly Likely	Near Certainty
Severe	Yellow	Red	Red	Red	Red
High	Yellow	Red	Red	Red	Red
Medium	Yellow	Yellow	3	2	1
Low	Green	Yellow	4	Red	Red
Minimal/None	Green	Green	5	Yellow	Yellow
<b>Note: Red – Critical, Yellow – Moderate, Green – Negligible</b> See Table 13 for risk number mapping					

**Table 13: Fire Scout with UAV Radar Decoy Alternative Risk Number Mapping**

Risk Number	Risk Significance	Risk Description
1	Critical	UAV Operability
2	Critical	Availability
3	Critical	Range
4	Moderate	Accuracy – Probability of Seduction
5	Moderate	Technology Readiness

The cost of improving the UAV radar decoy capability on a DDG could be high. According to Jane’s, the first production contract in the 1990s was worth \$67.8 million U.S. dollars, for 7,000 units of GEN-X decoy (IHS Jane's 2005). This price includes the whole development of the GEN-X decoy system, which includes the ALE dispenser as well. To outfit Fire Scouts with the GEN-X decoys today would cost more than that initial contract, and there are costs involved such as system equipment, product development, system procurement, and system installation. Table 14 shows the cost estimation which is based on the Navy budget for procurement of similar systems to the UAV radar decoy alternative. Team Crane assumed that there would be 62 DDGs to upgrade with the Fire Scout UAV radar decoy alternative. The cost estimate assumes the installation would take 5 years to complete, and the upgrade would have a total life cycle of 12 years. System procurement includes ALE-47 dispensers, installation of those dispensers, and GEN-X decoys as shown in Table 14. The system procurement is based on the ALE-47 dis-

dispensers having a \$0.06 million U.S. dollars unit cost in the Navy budget for dispenser procurement (Department Of the Navy Fiscal Year (FY) 2010 Budget Estimates 2009). Therefore, the total cost of ALE-47 dispensers on 62 Fire Scouts would be \$37.2 million U.S. dollars over 5 years. According to Department Of the Navy Budget Estimates 2009, total installation cost of 62 dispensers on Fire Scouts would be \$11.17 million U.S. dollars over 5 years (Department Of the Navy Fiscal Year (FY) 2010 Budget Estimates 2009). It is assumed that the Fire Scout platform will hold 10 dispensers. This alternative also assumes that while each dispenser can hold up to 30 decoys, 10 would be filled with GEN-X decoys, leaving room for other types of countermeasures. Therefore, with 10 dispensers per Fire Scout, and one Fire Scout per DDG, 620 dispensers would be needed for 62 DDGs. There would be 100 decoys per DDG, which would be a total of 6200 decoys on 62 DDGs. According to Navy budget estimates, GEN-X Decoy cost would be \$6105 per decoy, so that total cost of 6200 decoys would be \$37.851 million U.S. dollars over 5 years (Procurement of Ammunition, Navy and Marine Corps Budget Activity 1 2009).

System Test & Evaluation is based on 25% of the test and evaluation cost of the Electromagnetic Systems Applied research program on UAV deployable infrared sensor payloads for 5 years with total cost of \$7.37 million U.S. dollars (Research, Development, Test & Evaluation, Navy Budget Activity 1-3 2011). The management cost is based on 60% of the management cost of the Tactical Airborne Reconnaissance within the UAV Development Program (Navy Research, Development, Test and Evaluation 2012) for 12 years with a total cost of \$7.47 million U.S. dollars. The system sustainment is based on 30% of the cost estimation, from the Navy budget for Operation and Maintenance of the Surface Electronic Warfare Decoy for Fiscal Year 2012 (FY12) with a total of \$22.572 million U.S. dollars (Navy Operation and Maintenance 2012). Overall, the total cost to implement the Radar Decoy on Fire Scout Alternative across the DDG fleet of 62 ships is \$124.243 million U.S. dollars or \$2 million U.S. dollars per DDG for the 12 year life cycle.

**Table 14: Fire Scout with UAV Radar Decoy Alternative Cost Estimation**

Tasks	Reference Cost (\$M)	Quantity	Percentage of Effort vs. Reference Cost	Duration of Effort (Year)	Alternative Cost Estimate (\$M)
<b>SYSTEM DEVELOPMENT</b>	\$0.00	1	100%	0	\$0.00
<b>SYSTEM TEST &amp; EVALUATION</b> (Navy, Research, Development, Test and Evaluation 2012)	\$5.888	1	25%	5	\$7.37
<b>SYSTEM MANAGEMENT</b> (Navy, Research, Development, Test and Evaluation 2012)	\$1.038	1	60%	12	\$7.47
<b>SYSTEM PROCUREMENT</b>					
ALE-47 Dispenser Procurement (Department Of The Navy Fiscal Year (FY) 2010 Budget Estimates 2009)	\$0.06	620	100%	5	\$37.2
ALE-47 Installation (Department Of the Navy Fiscal Year (FY) 2010 Budget Estimates 2009)	\$0.019	620	100%	5	\$11.78
GEN-X Decoy (Procurement of Ammunition, Navy and Marine Corps Budget Activity 1 2009) (Procurement of Ammunition, Navy and Marine Corps Budget Activity 1 2009)	\$0.006105	6200	100%	5	\$37.851
<b>SYSTEM SUSTAINMENT</b> (Navy Operation and Maintenance 2012)	\$6.27	1	30%	12	\$22.572
<b>Total =</b>					\$124.243

**C. FIRE SCOUT UAV**

The Fire Scout Vertical Takeoff Unmanned Aerial Vehicle developed by Northrop Grumman is a helicopter-style UAV designed to perform reconnaissance missions for a destroyer. VTUAVs could assist a DDG with air defense in a number of ways.

The helicopter can be used to scout ahead of the DDG to provide situational awareness during port approach, using day/night cameras and infrared sensors to detect malicious UAVs. Various onboard weapon options exist for engaging UAVs. Anti-armor Hellfire missiles can be outfitted, along with Viper Strike Laser-Guided weapons. The most effective weapon currently outfitted on the helicopter is the Advanced Precision Kill Weapon System (APKWS), which are 2.75-inch laser-guided rockets with the ability to hit moving targets within 17 inches of the target (Barrie 2012). This weapon is most effective within the current UAV attack scenario, based upon the agility and speed it possesses to shoot down attack UAVs. Weapons that could be helpful against enemy UAVs, but have not yet been fitted for the Fire Scout are small caliber machine guns such as the M249 5.56mm, which are currently fielded as light handheld machine guns. These small caliber weapons, combined with the APKWS would add another contingency to combat attack UAVs. The control and command equipment required for this alternative includes the Fire Scout itself and the communications equipment which is used to control it. It is suggested that the Fire Scout could have the APKWS modifications for the fleet of DDGs for all missions, including the specific UAV attack scenario.



**Figure 21: Fire Scout (from BAE Systems 2012)**

Although the implementation of the UAV helicopter makes the DDG more protected against aerial attacks, there are associated risks involved. Obstacles that the UAV helicopter may face involve communications concerns, various controlling malfunctions,

and housing complications. The Fire Scout system has to have the ability to be operable which requires an information technology specialist, operator team, and a grounds crew for deployment and landing, increasing the ship’s personnel requirements. The helicopter uses a wireless data link connection, which is sometimes susceptible to latency of the data-link signal, which impedes real-time situational awareness as well as target engagement (Cubic 2012). This risk has been evident in field testing on the MQ-8B Fire Scout where failed test missions were attributed to signal latency. Command malfunctions, such as a command that initiates the self-destruction sequence, can also impede situational awareness and combat missions by not responding to user commands even while the communications are operated properly (Times 2011). The DDG is also burdened with being able to store the helicopter aboard the vessel. Storage spaces on DDGs are at a minimum. The unarmed Fire Scout has been developed and tested on the Littoral Combat Ship (LCS) platform in the U.S. Navy. Weapons systems have not yet been tested and the Fire Scout has not been fielded on any current DDGs. Based on the previous TRL discussion in the Risk Assessment section, a TRL of 6 is assessed, meaning that it has not been tested in a relevant environment against a UAV swarm attack (Times 2011). However, the risks involving integration, usability, and technology readiness are moderate overall.

**Table 15: Fire Scout UAV Risk Assessment**

<b>Risk Assessment</b>	Not Likely	Low Likelihood	Likely	Highly Likely	Near Certainty
Severe		2			
High					
Medium		3,4		1	
Low		5			
Minimal/None					
<b>Note: Red – Critical, Yellow – Moderate, Green – Negligible</b> See Table 16 for risk number mapping					

**Table 16: Fire Scout UAV Alternative Risk Number Mapping**

Risk Number	Risk Significance	Risks
1	Critical	Data link
2	Critical	Command Malfunctions
3	Moderate	Housing
4	Moderate	TRL6
5	Moderate	UAV Operations Staff

Based on Team Crane's assumption of 62 DDGs, and one Fire Scout UAV per ship, this alternative involves 62 total Fire Scouts integrated with APKWS. Based upon estimates from the Northrop Grumman MQ-8B Fire Scout, the UAV helicopter cost is approximately \$16.2 million U.S. dollars per UAV (Northrop-Grumman 2009), totaling \$1.004 billion U.S. dollars for the entire fleet. Spares and repair parts, bought at the same time as the initial UAV procurements, yield \$0.77 million U.S. dollars per UAV (Aeroweb n.d.), totaling \$47.74 million U.S. dollars. An average of the total cost across 21 existing UAVs, for spares during the 2011, 2012, and 2013 Fiscal Years, was taken and then multiplied by the fleet of 62 in the projected scenario.

Since DDGs are not currently outfitted for the Fire Scout a cost of \$1.47 million U.S. dollars per UAV is necessary for ship modifications yielding \$91.14 million U.S. dollars under procurement. This cost scales up from the \$41.4 million U.S. dollars in program related logistics support, currently budgeted for the 28 ships that would potentially house the MQ-8B UAVs previously purchased by the U.S. Navy (Navy, FISCAL YEAR (FY) 2012 BUDGET ESTIMATES 2011). The system test and evaluation cost for this alternative would be no larger than 50% of the current Fire Scout RDT&E costs of \$104.60 million U.S. dollars budgeted for 2013 ((Aeroweb) 2012). Multiplying this yearly cost by the assumed five year T&E period for the current scenario yields \$261.5M. The cost estimate for the APKWS rockets is based upon the Low Rate Initial Production Lot of 325 APKWS costing \$15.3 million U.S. dollars (Daily 2012). The \$15.3 million U.S. dollars is divided and the APKWS rockets are estimated to cost \$47,000 per rocket.

The Fire Scout is outfitted to carry 6 rockets per UAV, totaling \$282,000 per UAV. A cost of \$141,000 per UAV is also factored into the rocket procurement cost to provide each UAV with one set of three spare rockets, totaling \$26.23 million U.S. dollars for the entire fleet of UAVs. The rocket development is based on the budgeting for developing a training version of the APKWS rockets for the fixed wing A-10 platform with a baseline yearly cost of \$0.221 million U.S. dollars in 2011 (Center 2011). The design and development of the APKWS Fire Scout adaptation could last five years at that rate for a total of \$1.105 million U.S. dollars. Once development is complete, the cost for APKWS launcher integration for each Fire Scout should be no greater than 15% of the rocket procurement cost, which totals \$3.93 million U.S. dollars for the entire fleet. The

system management and sustainment costs originate from the Department of the Navy fiscal year baseline budget for special operations (Navy, Fiscal Year Budget (FY) 2009/FY 2010 2009) and maintenance support (Navy, Fiscal Year Budget (FY) 2013/FY 2014 2012) for the 28 MQ-8B UAVs currently in the field. The baseline costs were \$5.4 million U.S. dollars and \$47 million U.S. dollars respectively. These costs scaled up to accommodate the 62 DDG fleet. The main system development costs are based on the estimated systems development cost of \$605 million U.S. dollars for the Fire Scout program (Office 2010). As the assumed effort to integrate the Fire Scout on DDGs is much less than the original effort to develop the entire Fire Scout, the estimated cost should be no greater than 10% of the original development cost, yielding \$61.605 million U.S. dollars. These costs are included in Table 17. The grand total of \$2120.98 million U.S. dollars includes the complete life-cycle for the Fire Scout over a 12 year period.

**Table 17: Fire Scout UAV Cost Estimation**

<b>Tasks</b>	<b>Alternative Cost Estimate (DDG Fleet) (\$M)</b>	<b>Years</b>	<b>Life-Cycle (\$M)</b>
<b>System Development</b> (60.5+1.105)	61.605	5	61.605
<b>System Test &amp; Evaluation</b>	261.5	5	261.5
<b>System Management</b>	5.4	12	64.8
<b>System Procurement</b> (UAV manufacturing+APKWS (manufacturing and integration and spares)+ spares+ ship modifications)= (1.004B+26.23M+47.7M+91.14M) Estimated from FY 2011, 2012, 2013	1169.07	5	1169.07
<b>System Sustainment</b> (VTUAV Maintenance Support Baseline)	47	12	564
<b>Total =</b>			2120.98
<b>Total Without APKWS System=</b>			2093.64

#### **D. ADDITIONAL CIWS**

The alternative upgrade would be to double the number of CIWS per DDG. Currently, there are only 2 per DDG. This would not be a complicated upgrade, as the CIWS is already a program of record. This puts the CIWS at a TRL of 9. The most difficult part about this effort would be to find locations on the DDG that would be suitable for additional CIWS. Having one more in the front as well as one more in the back would be ide-



al, as it would essentially provide double the coverage. This configuration would allow 2 CIWS to cover the front, 2 to cover the back, and 4 to cover the sides. These additions would be the greatest and only risk associated with the CIWS alternative. It is a risk because finding good locations to mount the additional CIWS would be troublesome and might interfere with other shipboard systems. Table 18 and Table 19 provide the risk assessment and risk mapping.

The cost per CIWS is \$5.6 million U.S. dollars (Doehring 1999-2011). Since there would be 2 per DDG, a total cost of \$11.2 million U.S. dollars is an estimate of how much this alternative would cost per DDG. There would not be any additional R&D costs but there would be an increase to the current \$31.3 million U.S. dollars ( $\$3.2 + \$26.9 + \$1.2$ ) budgeted for CIWS maintenance per year based on the Navy FY 2012 budget (Fiscal Year (FY) 2012 Budget Estimates, DoN 2012). These costs come from the CIWS in-service engineering, maintenance engineering, and overhaul maintenance. Since these are numbers for the currently fielded CIWS and this alternative involves doubling the number per DDG, it would create an at most 25% increase in the current budgeted costs. This brings the cost per year for maintenance to \$7.825 million U.S. dollars ( $\$31.3 * 0.25$ ). The system management cost increase is estimated at 25% of the \$9.1 million U.S. dollars budgeted for systems engineering of the CIWS in the FY12 Navy budget. This cost is per year as well. Pages 250 and 261 of the Navy budget have this information. The ammunition costs should stay about the same, if the current amount of ammunition stays on the ship. This alternative is not to increase the duration that the CIWS can fire but rather increase the number of targets that can be engaged simultaneously. No additional suitability considerations need to be accounted for since they would just be included with the current CIWS. The results for the cost estimation can be seen in Table 20. The total cost over the 12 year life cycle will be \$815.6 million U.S. dollars across the fleet of 62 DDG or \$13.155 million U.S. dollars per DDG.

**Table 18: Additional CIWS Alternative Risk Assessment**

Risk Assessment	Not Likely	Low Likelihood	Likely	Highly Likely	Near Certainty
Severe	Yellow	Red	Red	Red	Red
High	Yellow	Red	Red	1	Red
Medium	Yellow	Yellow	Red	Red	Red
Low	Green	Yellow	Yellow	Red	Red
Minimal/None	Green	Green	Yellow	Yellow	Yellow
<b>Note: Red – Critical, Yellow – Moderate, Green – Negligible</b> See Table 19 for risk number mapping					

**Table 19: Additional CIWS Alternative Risk Number Mapping**

Risk Number	Risk Significance	Risks
1	Critical	Locations to put additional CIWS

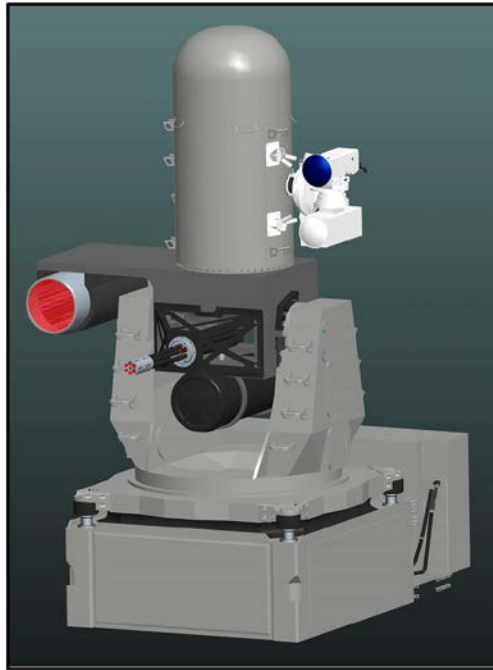
**Table 20: CIWS Alternative Cost Estimation**

Tasks	Reference Cost (\$M)	Percentage of Effort vs. Reference Cost (%)	Duration of Effort (Years)	Alternative Cost Estimate (\$M)
System Development	\$ 0	0%	0	=\$0
System Test and Evaluation	\$ 0	0%	0	=\$0
System Management	\$9.10	25%	12	=\$27.3
System Procurement	\$ 694.4 (\$11.2*62)	100%	5	=\$694.4
System Sustainment	\$ 31.3 (\$3.2+\$26.9+\$1.2)	25%	12	=\$93.9
<b>Total =</b>				\$815.60

**E. LAWS (LASER WEAPON SYSTEM)**

The Laser Weapon System (LaWS) alternative would be used to shoot down UAVs using a powerful laser. The LaWS solution produces an incoherent beam by combining six lasers in a closed packed ring topology of sub-apertures (Rourke 2011). This is fired through a beam combiner and expander and all six beams act as one single laser. The system can shoot down UAVs at shorter ranges and blind UAV sensors at longer ranges. The U.S. Navy has conducted two successful tests with the LaWS added to the

CIWS. The beam director of the LaWS is added to the left side of the CIWS mount and another LaWS component is bolted to the right side of the CIWS dome. A picture of this can be seen in Figure 22.



**Figure 22: Rendering of the LaWS on the CIWS (From Rourke 2011)**

In June 2009, LaWS successfully engaged five UAVs in a combat representative scenario in the desert. In May 2010, LaWS successfully engaged four UAVs in a combat representative scenario about one nautical mile off the California coast. This test demonstrated the ability to destroy UAVs in an over-the-water setting and the ability to reversibly jam and disrupt electro-optical/infrared sensors that would be located on a UAV. A LaWS with about 100 kW of power would be necessary to destroy a UAV and the Navy plans to increase the current beam power of 33 kW to 100 kW by 2014 (Rourke 2011).

With any alternative, there are advantages and limitations. Some advantages include the low marginal cost per shot. The Navy estimates that it would only cost pennies per shot fired with the LaWS compared to million U.S. dollars with missile defenses (Rourke 2011). There are also an unlimited number of shots that can be taken with the LaWS, as long as the platform can supply electricity. Lasers also travel at the speed of light, so a fast engagement time is another advantage. In addition, radically maneuvering

air targets cannot escape the speed and precision of a laser. There is also a low risk of collateral damage with lasers because they are so precise. These advantages eliminate suitability considerations as risks.

Lasers can only attack one target at a time and it can take several seconds to disable the target in question. This means that only having one laser on a ship could be a problem for multiple fast moving targets, such as suicidal UAVs. This is also the greatest risk given that 8 UAVs need to be engaged at one time. The limitations are the risks in the case of LaWS (Rourke 2011). Table 21 and Table 22 present the risk assessment and risk mapping.

**Table 21: LaWS Alternative Risk Assessment**

<b>Risk Assessment</b>	Not Likely	Low Likelihood	Likely	Highly Likely	Near Certainty
Severe					
High					
Medium				1	
Low		2			
Minimal/None					
<b>Note: Red – Critical, Yellow – Moderate, Green – Negligible</b> See Table 22 for risk number mapping					

**Table 22: LaWS Risk Number Mapping**

<b>Risk Number</b>	<b>Risk Significance</b>	<b>Risks</b>
1	Critical	Number of Targets
2	Moderate	TRL

As of December 2010, LaWS was at a TRL of 5. The Navy estimates that it might cost \$150 million U.S. dollars to develop and test LaWS to TRL 7. The Navy believes a production version of LaWS could be on surface ships around FY2017. Since this would be a 5 year effort, 20% of the cost would be allocated per year. This can be seen with the cost estimation process in Table 23. The Navy also estimates that the production copies could be installed and procured as additions to ship CIWS mounts for a total cost of \$17 million U.S. dollars per CIWS mount (Rourke 2011). There would be no ordnance costs, no logistics tail for maintaining the ordnance, and no fire suppression costs associated with the LaWS. The sustainment cost for the LaWS is estimated to increase the current

\$31.3 million U.S. dollars (\$3.2+\$26.9+\$1.2) budgeted for CIWS maintenance per year based on the Navy FY 2012 budget (Navy 2011). These costs come from the CIWS in-service engineering, maintenance engineering, and overhaul maintenance. These numbers are for the currently fielded CIWS, and the addition of LaWS to the CIWS would create an estimated 25% increase in the current budgeted costs. This brings the cost per year for maintenance to \$7.825 million U.S. dollars (\$31.3\*0.25). The system management cost is estimated at 25% of the \$9.1 million U.S. dollars in the FY12 Navy budget for the systems engineering of the CIWS. This cost is per year as well (Navy 2011, 250, 261). Since there are currently 2 CIWS per destroyer, the total procurement cost per destroyer would be \$2108 million U.S. dollars (\$17\*2). The results for the cost estimation can be seen in Table 23. The total cost over the life cycle will be \$2379.2 million U.S. dollars.

**Table 23: LaWS Cost Estimation**

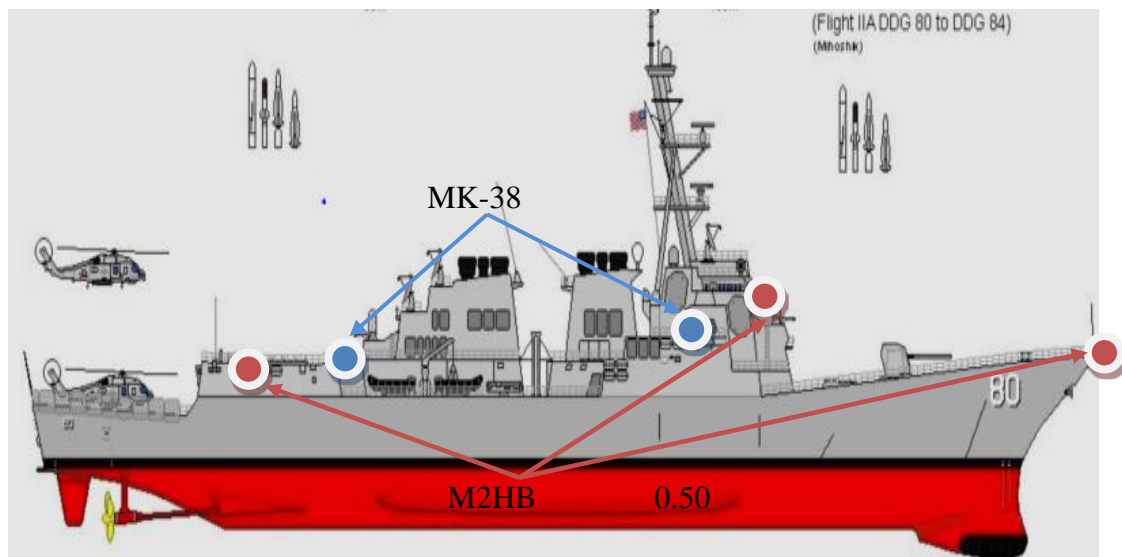
<b>Tasks</b>	<b>Reference Cost</b> (\$M)	<b>Percentage of Effort vs. Reference Cost</b> (%)	<b>Duration of Effort (Years)</b>	<b>Alternative Cost Estimate</b> (\$M)
<b>System Development</b>	\$ 100	20%	5	=\$100
<b>System Test and Evaluation</b>	\$ 50	20%	5	=\$50
<b>System Management</b>	\$9.1	25%	12	=\$27.3
<b>System Procurement</b>	\$ 2108 (34*62)	100%	5	=\$2108
<b>System Sustainment</b>	\$ 31.3 (\$3.2+\$26.9+\$1.2)	25%	12	=\$93.9
<b>Total=</b>				2379.2

**F. ADDITIONAL SMALL ARMS**

As previously discussed in the section titled “AEGIS DDG Defensive Capabilities,” small arms mounts provide the DDG with a last line of defense against incoming UAVs. The following proposed alternative increases the number of small arms mounts in an attempt to defend the DDG from a swarm of UAVs. The additional mounts include a

combination of the MK-38 MOD2 and the M2HB 0.50 caliber machine gun with Common Remotely Operated Weapon Station (CROWS) II (M2HB 0.50 CROWS II).

This alternative involves the combination of two additional MK-38 MOD2 mounts, one M2HB 0.50 CROWS II mount, and upgrading the current four M2HB 0.50 machine guns to the M2HB 0.50 CROWS II mount. The CROWS II was designed for small weapon systems and adds a thermal imager with autofocus and e-zoom, an eye safe laser range finder, a color daylight camera, and it stabilizes the weapon system with respect to the ship's movement, providing target tracking and engagement capabilities (Army Guide 2008). The implementation of the combination of M2HB 0.50 CROWS II and the MK-38 MOD2 would provide safety for the operators and increase the accuracy, firepower, and area of protection for the DDG against UAV swarm attacks. The layout of the Small Arms Alternative is shown in Figure 23.



**Figure 23: Layout of Small Arms Mounts Alternative (After Seaforges.org 2012)**

There are risks associated with the implementation of the Small Arms Mounts Alternative. The MK-38 MOD2 has been developed, tested, integrated, and fielded. The M2HB 0.50 CROWS II has been widely used on variety of platforms in the U.S Armed Forces. The Program Offices have been in place to procure, manage, and sustain these small arms mounts. Additional small arms mounts would require additional operators which could increase personnel requirements. However, the risk associated with training

new operators is low because the Navy can utilize the existing training programs for these small arms mounts for additional crew to operate the additional small arms mounts.

The small arms mounts have been developed, tested, and fielded on variety of platforms in the U.S. Armed Forces. However, they have not been tested against a UAV swarm attack. Based on previous TRL discussion in the Risks Assessment Section, Team Crane assesses the technology readiness of the small arms mounts against a UAV swarm attack at TRL8. Therefore, the risks involving integration, availability, usability, sustainment, and technology readiness are low.

The upgraded M2HB 0.50 caliber machine guns with the CROWS II system would increase the accuracy of the M2HB 0.50 caliber machine guns, as well as provide more safety for the DDG crew with the remote controlled capability. The combination of MK-38 MOD2 and M2HB 0.50 CROWS II implementation also provides additional area of protection to the DDG against not only UAV swarm attacks but small boats attacks as well. However, the small arms mounts still have limitations due to the required ammunition reload, which poses a high risk to the crew during combat. In particular, larger UAVs would require more hits from small arms mounts in order to be neutralized, reducing the effectiveness of the additional mounts. Therefore, the limitation of small arms firepower, ammunition load capacity, and range incur high risk to neutralize UAVs swarm attacks on their own. Table 24 and Table 25 provide the risk assessment and the risk mapping.

**Table 24: Small Arms Mounts Alternative Risks Assessment**

<b>Risk Assessment</b>	Not Likely	Low Likelihood	Likely	Highly Likely	Near Certainty
Severe					
High				1,2,3	4
Medium					
Low	9	5,7,8	6		
Minimal/None					
<b>Note: Red – Critical, Yellow – Moderate, Green – Negligible</b> See Table 25 for risk number mapping					

**Table 25: Small Arms Mounts Alternative Risks List**

<b>Risk Number</b>	<b>Risk Significance</b>	<b>Risk Description</b>
1	Critical	Small Arms Mounts Range
2	Critical	Small Arms Mounts Accuracy
3	Critical	Small Arms Mounts Fire Power
4	Critical	Ammunition Load and Reload
5	Moderate	Integration with DDG Baseline Combat System
6	Moderate	Additional Personnel Requirement
7	Moderate	Small Arms Mounts Availability
8	Moderate	Small Arms Mounts Sustainability
9	Negligible	Technology Readiness

The cost to implement the small arms mounts alternative is low. Since the small arms mounts have been developed, tested, and fielded, there would be no cost for system development. In addition, there would be costs for small arms mounts procurement, installation, and sustainment, as well as minor costs for system acceptance test and management. Team Crane assumed that there would be 62 DDGs (DDG 51— DDG 112) to upgrade with the Small Arms Mounts Alternative. The cost estimate assumes that the installation would take 5 years to complete, and the upgrade would have the total life-cycle of 12 years. The system T&E is based on 25% of the Navy budget for Precision Strike Weapons Development Program, carrier suitability testing (Navy Research, Development, Test and Evaluation 2012) for five years with a total of \$1.25 million U.S. dollars because only government acceptance tests to validate the small arms mounts installation are required for this alternative instead of full development T&E. The system procurement is based on the MK-38 MOD2 \$1.13 million U.S. dollars unit cost and the M2HB 0.50 caliber machine gun \$0.014 million U.S. dollars unit cost from the Navy budget for weapons procurement (Navy Weapons Procurement 2012) and the CROWS II \$0.08 million U.S. dollars average unit cost from the CROWS II program (Army Guide 2008). Assuming that the small arms mounts installation cost is 50% of the unit cost, procurement totals \$251.10 million U.S. dollars spread over five years. The system sustainment is based on 30% of the cost estimation from the Navy budget for Operation and Maintenance of the Joint Advanced Strike Technology for FY12 with a total of \$100.8 million U.S. dollars (Navy Operation and Maintenance 2012). The management cost is



based on 60% of the management cost of the Very Low Collateral Damage Weapon project within the Precision Strike Weapons Development Program (Navy Research, Development, Test and Evaluation 2012) for 12 years with a total cost of \$8.64 million U.S. dollars. Overall, the total cost to implement the Small Arms Mounts Alternative across the DDG fleet of 62 is \$361.79 million U.S. dollars or \$5.84 million U.S. dollars per DDG for the 12 year life cycle. All of these cost estimates can be found in Table 26.

**Table 26: Small Arms Mounts Cost Estimation Summary**

<b>Tasks</b>	<b>Reference Cost (\$M)</b>	<b>Quantity</b>	<b>Percentage of Effort vs. Reference Cost</b>	<b>Duration of Effort (Year)</b>	<b>Alternative Cost Estimate (\$M)</b>
<b>SYSTEM DEVELOPMENT</b>	\$0.00	1	100%	0	\$0.00
<b>SYSTEM TEST &amp; EVALUATION</b> (Navy Research, Development, Test and Evaluation 2012)	\$1.00	1	25%	5	\$1.25
<b>SYSTEM MANAGEMENT</b> (Navy Research, Development, Test and Evaluation 2012)	\$1.20	1	60%	12	\$8.64
<b>SYSTEM PROCUREMENT</b>					\$251.10
MK 38 MOD2 Procurement (Navy Weapons Procurement 2012)	\$1.13	124	100%	5	\$139.62
MK 38 MOD2 Installation (Navy Weapons Procurement 2012)	\$0.56	124	100%	5	\$69.94
M2HB 50 Cal (Navy Weapons Procurement 2012)	\$0.014	62	100%	5	\$4.34
CROWS II (Army Guide 2008)	\$0.08	310	100%	5	\$24.80
M2HB 50 CROW II Installation (Estimation=50% cost of procurement cost)	\$0.04	310	100%	5	\$12.40
<b>SYSTEM SUSTAINMENT</b> (Navy Operation and Maintenance 2012)	\$28.00	1	30%	12	\$100.80
<b>Total =</b>					\$361.79

## **G. ELECTRONIC WARFARE (EW) JAMMING**

This alternative extends the current EW capabilities of the DDG to full spectrum coverage in order to defeat RC UAVs. The Harpy UAVs would not be affected by this improvement, as they use GPS as their guidance system until there is a radar signature detected which then guides them to the target (Harpy Air Defense Suppression System

2006). This means there would be no guidance signal to jam. There will be a full 360 degrees of coverage from the EW improvement. The technical capabilities of the EW improvement (such as frequency, distance, techniques, output power, etc.) are classified information and will not be discussed further.

To defeat a RC UAV using EW, the uplink and/or downlink signal(s) would need to be disrupted. Jamming the RC UAV's datalink can execute a soft kill by denying the operators command guidance capability. If the UAV is being piloted by a remote operator, loss of the command guidance signal can cause a hard kill to the UAV. This would only happen if no automatic return to home capability is implemented on the loss of the datalink (Mirkarimi 2003). Another alternative outside the scope of this project includes intercepting and acquiring the UAV's datalink signals and using them to determine what the threat system is seeing. If it is targeting the DDG, the system could replicate the signals to surreptitiously insert false return-to-home coordinates, or turn off vital flight control systems. This is a more advanced alternative that would require more research.

There are risks associated with the requirements that the EW alternative must meet. These include spectrum, threat speed, engagement range, and energy signature. The energy signature, engagement range, and threat speed are the highest risks. Increasing the spectrum coverage would require time, research, integration efforts, testing, and money. There could be difficulty successfully integrating the upgraded system with the DDG. The threat speed is high risk because there is the possibility that the UAV could reach the destroyer if the signal cannot be jammed fast enough. The engagement range is high risk because the power will need to be kept down due to the near-shore scenario, meaning that the EW alternative might not be effective far enough out to prevent a collision. The energy signature is high risk because the jammer could be too high power which can be very dangerous when higher power outputs are used with a near-shore scenario. This also means that the RF radiation could violate local frequency control laws and could make the DDG a more noticeable target to Harpy UAVs.

The technology readiness is not a risk because the TRL is at an 8. The technology already exists but has not been integrated into DDGs yet. This leads to the last risk, extensibility. The extensibility could be a risk because the EW alternative upgrade might

not be a feasible upgrade with the current EW systems aboard the DDG. There could be hardware integration issues with the existing radar or EW systems.

**Table 27: EW Alternative Risk Assessment**

Risk Assessment	Not Likely	Low Likelihood	Likely	Highly Likely	Near Certainty
Severe					
High				2	1
Medium		4,5	3		
Low					
Minimal/None					
<b>Note: Red – Critical, Yellow – Moderate, Green – Negligible</b> <b>See Table 28 for risk number mapping</b>					

**Table 28: EW Alternative Risk Number Mapping**

Risk Number	Risk Significance	Risks
1	Critical	Energy Signature
2	Critical	Engagement Range
3	Critical	Threat Speed
4	Moderate	Spectrum
5	Moderate	Extensibility

Table 29 shows a cost estimate to extend the current EW capabilities of the DDGs to full spectrum coverage.

**Table 29: EW Alternative Cost Estimation**

Tasks	Reference Cost (\$M)	Percentage of Effort vs. Reference Cost (%)	Duration of Effort (Years)	Alternative Cost Estimate (\$M)
<b>System Development</b>	\$ 47.22	100%	5	=\$236.1
<b>System Test and Evaluation</b>	\$ 4.52	100%	5	=\$22.6
<b>System Management</b>	\$2.1	100%	12	=\$25.2
<b>System Procurement</b>	\$ 632 (10.2*62)	20%	5	=\$632
<b>System Sustainment</b>	\$ 9.4	100%	12	=\$112
<b>Total =</b>				<b>\$1,027.9</b>

Team Crane has assumed that there would be 62 DDGs that need to be upgraded with the EW capabilities alternative. The cost estimate assumes that the installation would take 5 years to complete, and the upgrade would have the total life-cycle of 12 years.

The development cost to extend the current EW capabilities is \$236.1 million U.S. dollars. The cost is assumed to be the 7% of Navy 2012 budget for EW Combat Support (Research, Development, Test and Evaluation, Navy 2012). Extending the EW capabilities would require 7% of the assigned budget due to the complexity of upgrading existing capabilities. The most common barriers are compatibility and integration with other systems.

The total cost for the EW capabilities alternative test & evaluation is estimated to be \$22.6 million U.S. dollars. The cost is assumed to be the same cost as the Navy FY06 budget for the Shipboard EW Improvement test and evaluation support (DoN 2006).

The total system management cost for the EW capabilities alternative is \$2.1 million U.S. dollars per year, for a total cost of \$25.2 million U.S. dollars for 12 years. The cost is assumed to be the same cost as the Navy FY 05 budget for the Shipboard EW Improvement support (DoN 2006).

The procurement cost for the EW capabilities alternative is \$10.2 million U.S. dollars per DDG, with total cost of \$632 million U.S. dollars for the 62 DDGs. The procurement cost is assumed to be the same as the Navy FY 2011 budget estimated for the SLQ-32 EW Block 2 electronic support improvements (DoN 2011).

The sustainment total cost is \$9.4 million U.S. dollars per year. The cost for the entire fleet (62 DDGs) for a 12-year period is \$112 million U.S. dollars. The system sustainment cost is assumed to be the same as the Navy 2010 budget estimates for the SLQ-32 system support (DoN 2011). The total cost to extend the current EW capabilities alternative for the entire fleet composed of 62 DDGs is \$1.028 billion dollars for the 12 year life cycle.

## **H. SHIP BASED RADAR DECOY**

Ship-based radar decoys provide the DDG protection against incoming missile attacks and send the threat away. They could also provide similar protection against the radar-seeking Harpy UAVs. The ship-based radar decoy alternative could make use of a decoy launcher developed by Lockheed Martin. This decoy launcher is called the Automatic Launch of Expendable (the ALEX). The decoys attempt to attract threats away from the ship (Lockheed Martin 2012).



**Figure 24: Lockheed Martin’s ALEX system (From Lockheed Martin 2012)**

The ALEX system is capable of operating as stand-alone equipment. It also can interface with a ship’s electronic support systems (Jane's Radar And Electronic Warfare Systems 2011).

There are risks involved with integrating a system like ALEX on DDGs. This system depends on computer-controlled operation to launch decoys. There is high risk of electronics failure because occurrence of a failure during real-time operation could prevent a decoy from launching in time to attract a threat. Redeployment risk is moderate because the system can be upgraded based on customer need to use more advanced decoy cartridges. Accuracy has a minimal risk because launch timing is automatic and can be overridden to manual control for better timing accuracy. The TRL is not a risk for this system because the TRL is at an 8. The technology already exists but has not been integrated into DDGs yet.

**Table 30: Ship Based Radar Decoy Alternative Risk Assessment**

Risk Assessment	Not Likely	Low Likelihood	Likely	Highly Likely	Near Certainty
Severe	Yellow	Red	Red	Red	1
High	Yellow	Red	Red	2	Red
Medium	Yellow	Yellow	Red	1	Red
Low	Green	4	3	Red	Red
Minimal/None	Green	5	Red	Yellow	Yellow
<b>Note: Red – Critical, Yellow – Moderate, Green – Negligible</b> See Table 31 for risk number mapping					

**Table 31: Ship Based Radar Decoy Alternative Risk Mapping**

<b>Risk Number</b>	<b>Risk Significance</b>	<b>Risks</b>
1	Critical	Interference with Detection systems
2	Critical	Launch Control Reliability
3	Moderate	Redeployment re-loading
4	Moderate	Logistics
5	Negligible	Accuracy – Probability of Seduction

The cost to implement the Ship-based Radar Decoys alternative is high. The costs will include ship-based radar decoys procurement, installation, sustainment, test and evaluation, and system management. Team Crane assumed that there are 62 DDGs to upgrade with the Ship-based Radar decoy system alternative. The cost estimate assumes that the installation would take 5 years to complete, and the upgrade would have a total life cycle of 12 years. The system test and evaluation is based on 25% of the Navy budget for NULKA Decoy Development program (Navy, Research, Development, Test and Evaluation 2012) for five years with a total of \$3.29 million U.S. dollars. The management cost is based on 60% of the management cost of the Anti-ship missile decoy system for NULKA Decoy project (Navy Research, Development, Test and Evaluation 2012) for 12 years with a total cost of \$2.304 million U.S. dollars. The system procurement is based on the NULKA Decoy system cost of \$14.294 million U.S. dollars per launch system which also includes 10 NULKA decoys. Thus, the total cost for 62 systems for 62 DDGs would be \$886.228 million U.S. dollars based on the Navy budget for Anti-ship missile decoy system (Department Of the Navy Fiscal Year (FY) 2012 Budget Estimates 2011). Based on the Anti-missile decoy system installation (Department Of the Navy Fiscal Year (FY) 2012 Budget Estimates 2011) for 1 system, installation would cost \$1.6 million U.S. dollars, so the total cost would be \$111.6 million U.S. dollars spread over five years. The system sustainment is based on 30% of the cost estimation from the Navy budget for Operation and Maintenance of the Anti-Ship Missile Decoys for Fiscal Year 12 (FY12) with a total of \$27.288 million U.S. dollars (Navy Operation and Maintenance 2012). Overall, the total cost to implement the Ship-Based Radar Decoy System Alternative across the DDG fleet of 62 ships is \$1.1083 billion U.S. dollars or \$16.42 million U.S. dollars per DDG for the 12 year life cycle.

**Table 32: Ship Based Radar Decoy Alternative Cost Estimation**

<b>Tasks</b>	<b>Reference Cost (\$M)</b>	<b>Quantity</b>	<b>Percentage of Effort vs. Reference Cost</b>	<b>Duration of Effort (Year)</b>	<b>Alternative Cost Estimate (\$M)</b>
<b>SYSTEM DEVELOPMENT</b>	\$0.00	1	100%	0	\$0.00
<b>SYSTEM TEST &amp; EVALUATION</b> (Navy, Research, Development, Test and Evaluation 2012)	\$2.632	1	25%	5	\$3.29
<b>SYSTEM MANAGEMENT</b> (Navy, Research, Development, Test and Evaluation 2012)	\$0.320	1	60%	12	\$2.304
<b>SYSTEM PROCUREMENT</b>					
Ship-based radar launch system Procurement (including decoys) (Department Of the Navy Fiscal Year (FY) 2012 Budget Estimates 2011)	\$14.294	62	100%	5	\$886.228
Ship-based Radar Decoy Installation (Department Of the Navy Fiscal Year (FY) 2012 Budget Estimates 2011)	\$1.6	62	100%	5	\$99.2
<b>SYSTEM SUSTAINMENT</b> (Navy Operation and Maintenance 2012)	\$7.58	1	30%	12	\$27.288
<b>Total =</b>					\$1018.31

**I. SMOKESCREEN ALTERNATIVE**

The smokescreen generator system is one of the proposed alternatives to deter, prevent and/or defeat RC UAV attacks against DDGs. The smokescreen generator alternative would improve the DDG’s ability to defeat UAV swarm attacks by providing an additional layer of defensive capability. When a UAV threat is detected by any of the DDG detection mechanics, the smokescreen generator system discharges a smokescreen providing full 360 degree coverage.

The smokescreen generator alternative is very effective against a UAV swarm attack due to its ability to protect the DDG by disrupting the optical link between the RC UAV controller and the UAV, prompting the UAV to crash into the water or fly away

from the DDG while providing more time to the DDG to generate an offensive response. RC UAVs are controlled remotely by the operator; the absence of visibility from the operator makes it extremely difficult to operate the UAV.

A smokescreen is a deceptive tactic which dates back thousands of years, and has been used successfully through human history. For example, the ancient Greeks were known for their astuteness in battlefield matters, and were pioneers of the smokescreen, which was largely used during the Peloponnesian War, 431 to 404 BC (Smart 1997).

The smokescreen was frequently used during World Wars I and II, but its use was discontinued due to the negative effect on human health and the environment; challenges from the past still remain as an obstacle to the implementation of the smokescreen generator alternative on U.S. destroyers. The bigger concerns and/or obstacles are described by the Army and other military branches as “exposure to heavy smoke concentrations for extended periods (particularly if near the source of emission) may cause illness or even death” (ARMY, et al. 1995).

Currently, a smoke generator does not exist that is able to cover a DDG in a matter of seconds to avoid UAV swarm attacks. The development and design of a smokescreen generator with the said capacities is a high risk acquisition. The reason it is high risk is because the development of new technologies is not an easy task; delays, cost, technology maturity and development constraints can all contribute toward program failure.

Table 33 shows a risk assessment of the risks associated with the smokescreen generator alternative, and provides adequate information to predict the impact of the risk and the likelihood that each will occur.

**Table 33: Smokescreen Alternative Risk Assessment**

<b>Risk Assessment</b>	Not Likely	Low Likelihood	Likely	Highly Likely	Near Certainty
Severe					
High				2,3	1,4
Medium			5		
Low				6	
Minimal/None					
<b>Note: Red – Critical, Yellow – Moderate, Green – Negligible See Table 34 for risk number mapping</b>					



Some of the risks associated with the alternative are showed in Table 34. The smokescreen generator alternative will affect any enemy RC UAV, but also affect friendly systems and weapons in the vicinity, due to the nature of the alternative (which releases a smokescreen into the air). The operational environment is a high risk item; the release of smoke into the air will affect some ship defense systems, such as small arms, due to the lack of visibility. Another high risk item is the hazard to human health, as the residue of the smoke can cause respiratory problems, skin problems or even death. The crew must wear gas masks when the smoke generator is being used (ARMY, et al. 1995).

**Table 34: Smokescreen Alternative Risk Mapping**

<b>Risk Number</b>	<b>Risk Significance</b>	<b>Risk Description</b>
1	Critical	Operational Environment
2	Critical	Small Arms
3	Critical	Visual surveillance
4	Critical	Human Health Hazard
5	Moderate	Technology Readiness Level
6	Moderate	Friend or Foe Identification

Technology readiness represents an additional risk. The smoke screen alternative is feasible; it has been used in military vehicles to cover small areas, but not on a large scale, such as on Navy ships (Military Analysis Network 2000). Therefore, the TRL of the smokescreen generator alternative is TR5, and further development is needed in order to implement and field a system able to disrupt a UAV attack swarm. One of the bigger challenges is the location and installation of the generators, and the exhaust pipes transporting the smoke coming out of the generators. The logistics involved may require the ship to stay in port for months while such an installation is performed.

The requirements for the smokescreen generator alternative for Navy ship applications are that it would need to be able to cover the average area of a DGG of 4150 m<sup>2</sup> within 7 seconds or less, and in doing so, be able to protect the DDG against a UAV swarm attack detected at medium to long range (500m - 1000m). The M157A2 smoke release rate is classified. However, for academic purposes, it is assumed that the M157A2 is capable of covering 68 m<sup>2</sup> over a twenty second time period. An area of 68 m<sup>2</sup> is assumed because it is sufficient to cover a group of three MMWV simultaneously. Given

that the ship area of 4150 m<sup>2</sup> is 61 times larger than the vehicle area of 68 m<sup>2</sup>, 61 generators are needed to cover the DDG.

Table 35 shows a cost estimate for a smokescreen generator system. The requirement is to cover 61 times more area than a single M157A2's capabilities in order to provide adequate protection to DDGs.

**Table 35: Smokescreen Alternative Cost Estimation**

<b>Tasks</b>	<b>Life cycle Alternative Cost Estimate (DDG Fleet) (M)</b>
<b>SYSTEM DEVELOPMENT</b>	\$100.00
<b>SYSTEM TEST &amp; EVALUATION</b>	\$14.4
<b>SYSTEM MANAGEMENT</b>	\$24
<b>SYSTEM PROCUREMENT</b>	\$1781
<b>SYSTEM SUSTAINMENT</b>	\$94.8
<b>Total =</b>	\$2.014 Billion

Team Crane has assumed that there would be 62 DDGs (DDG 51—DDG 112) to be upgraded with the smokescreen generation alternative. The cost estimate assumes that the installation would take 5 years to complete, and the upgrade would have the total life-cycle of 12 years.

Not enough economic data of the M157A2 was found to determine the cost incurred to develop the system. The M58 Wolf Smoke Generator has similar functionality to the M157A2 (Military Analysis Network 1995). The M58 and M157A2 economic data is used to estimate the total cost for the DDG smokescreen generator.

The development cost of the M157A2 is assumed to be \$8.8 million U.S. dollars (Department of the Army Financial Management and Comptroller 1997). The assumed estimate development cost is \$100 million U.S. dollars, and it is assumed to increase drastically in comparison with the M157A2, due to the amount of effort to redesign and integrate the smokescreen generator with other systems in the DDG. The generators to be developed and installed on the DDGs are to be able to cover 61 times more area than the M157A2, but in half of the time. The smokescreen alternative has not been developed and tested to cover an area equivalent to the size of a DDG. Research and experimentation would be required to mature the technology.

The total cost for the DDG smokescreen system test and evaluation is assumed to be \$14.4 million U.S. dollars. The cost is assumed to be the same cost as the Army FY 1997 budget for the smoke, obscurant and target defeating system engineering development (Department of the Army Financial Management and Comptroller 1997).

The total system management cost for the smoke screen alternative is \$2 million U.S. dollars per year, for a total cost of \$24 million U.S. dollars for 12 years. The cost is assumed to be the same cost as the Army FY 2003 budget for the M56/58 smokescreen generator system (Department of the Army Procurement Programs 2003).

The procurement cost is based on the Army FY 2003 budget estimated for the M56/58 smokescreen generator system, with a cost of \$362,142 each (Department of the Army Procurement Programs 2003). The procurement total cost for 62 DDG systems is assumed to be 30% greater than the Army FY 2003 budget estimated for the M56/58, because the DDG version would require more research and development, is highly difficult to install, and finally, requires more design effort, as the system is more complex. The total cost for the procurement per DDG is \$28.72 million U.S. dollars, given by \$362,142 times 61 plus 30%. The total procurement cost for the DDG alternative (for the 62 DDGs) is \$1.8 billion dollars.

The sustainment total costs are \$7.9 million U.S. dollars per year. The cost for the entire fleet (62 DDGs) for a 12-year period is \$94.8 million U.S. dollars. The system sustainment cost is assumed to be the same as the Army 2003 budget estimates for smoke generator systems, with a cost of \$7.9 million U.S. dollars per year (Department of the Army 2002).

The total cost to implement the smokescreen alternative for the entire fleet composed of 62 DDGs is \$2.014 billion dollars for the 12 year life cycle.

## **J. REACTIVE ARMOR**

The Tactical Rocket-Propelled Grenade (RPG) Airbag Protection System (TRAPS) system involves 'close-in' protection using airbags located around a vehicle to minimize the damage from RPGs. This system was designed by Textron. The Chief Technology Officer Thomas McNamara, of Textron Systems Corporation had this to say about TRAPS:

The system is compatible with multiple military vehicle types, and it delivers reliable, robust performance against different RPG threats while minimizing costly, time-consuming modifications and vehicle recertification tests. In addition, TRAPS offers significantly lower weight and demonstrated lower collateral damage than competing active protection systems. Following the successful Object Storage Device (OSD) testing, we are prepared to deliver the customer a mature, affordable and rapidly deployable active vehicle protection solution. (Eshel 2010)

The proposed alternative for reactive armor would be to use the TRAPS system to help defeat UAVs at a close range if they were to penetrate through all other defense systems. The idea would be to locate TRAPS around the DDG in critical locations to help minimize the damage to the hull as well as to antennas. One team member spoke with the program director of TRAPS to determine how TRAPS could be used to help defend against UAVs. His recommendation was to not use TRAPS at all, as it would not be effective against suicidal UAVs. He made it very clear that the TRAPS system was designed for smaller threats like RPGs and would have very little effect against a larger threat such as a UAV. He also made the point that the UAV could not be defeated at that close of a range, as it is a threat with just too much mass. His suggestion was to stick to other alternatives that involved defeating UAVs away from the DDG. Per his recommendation, the team decided that the reactive armor alternative is not a feasible alternative for this project. The costs, risks, and TRL still need to be addressed. Since the current technology would not be applicable to the UAV threat, the TRL is at 0. The costs could not be estimated, since nothing has been started with this technology. The risks include cost, TRL, scalability, and usability. Cost is a risk because it is unknown how much this alternative would cost. TRL is risk because basic technology research has not even been started. Usability is a risk with this system because there is only one use per TRAPS installation. Scalability is a risk; if the current TRAPS were to be scaled up to be a defensive solution for a DDG then it might not be effective at all, as the TRAPS program director stated. Table 36 and Table 37 provide the risk assessment and the risk mapping.

**Table 36: TRAPS Alternative Risk Assessment**

<b>Risk Assessment</b>	Not Likely	Low Likelihood	Likely	Highly Likely	Near Certainty
Severe			2		
High			4		1
Medium					
Low					3
Minimal/None					
<b>Note: Red – Critical, Yellow – Moderate, Green – Negligible</b> See Table 37 for risk number mapping					

**Table 37: TRAPS Alternative Risk Mapping**

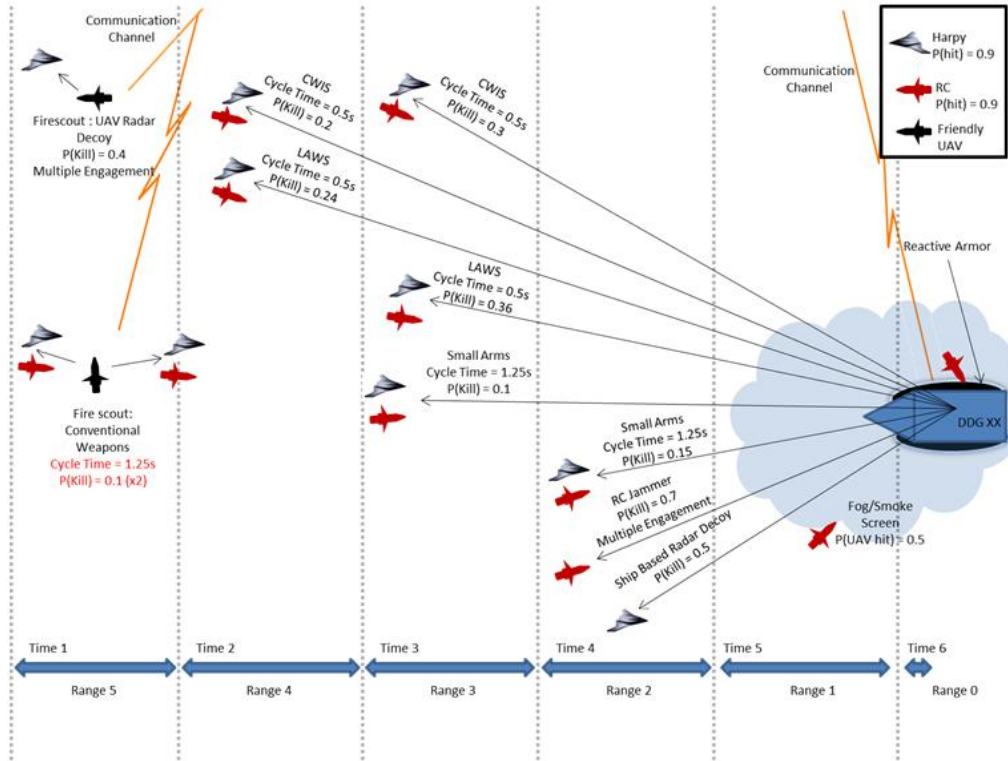
<b>Risk Number</b>	<b>Risk Significance</b>	<b>Risks</b>
1	Critical	TRL
2	Critical	Cost
3	Moderate	Usability
4	Moderate	Scalability

## **VI. SYSTEM ALTERNATIVE MODEL RESULTS AND COST BENEFIT ANALYSIS**

This section evaluates the engagement alternatives, discussed in the previous section, based on how well the alternatives improve the performance over the modeled baseline. After modeling results have been established for the engagement alternatives, a cost benefit analysis was conducted. The results of the cost benefit analysis identified the most economical alternatives and the potential combinations of alternatives that are predicted to protect the DDG from a swarm of UAVs.

### **A. MODEL RESULTS**

The results for each alternative are displayed to convey the effectiveness in comparison to the baseline model results. Each alternative was an addition to the baseline model using the Monte Carlo method to analyze results. Figure 25 shows a pictorial representation of how the alternatives were modeled and their basic modeling parameters.



**Figure 25: Modeling Parameters for Alternatives**

Figure 25 displays the associated range for each alternative as well as what type of UAV the alternative is able to engage. The ranges represent distance from the DDG with Range 5 being the farthest from the ship and Range 0 being the actual ship. For example, it can be seen that the RC Jammer is only able to engage the RC UAVs at Range 2, whereas CIWS is able to engage both the RC and Harpy UAVs at both Ranges 3 and 4. It can be noted that the P(kill) for CIWS and LAWS is increased at a closer range.

The modeling results for the alternatives were put in terms of the outcome probability for the number of successful suicide UAVs, to better demonstrate comparison to the baseline. For each alternative, the team conducted a simulation of 500 trials, and each trial resulted in a number of UAV hits scored on the DDG, ranging from zero to eight. The simulation data showed how many of those 500 runs resulted in each possible outcome. Dividing the number of runs resulting in each outcome by 500 yielded a probability. The graphs show cumulative outcome probability, making it easy to see how likely it is to have no more than a given number of UAVs impact the ship. In order to demonstrate

each alternative's percent decrease in UAV hits scored on the DDG from the baseline model, the average number of UAV hits was recorded for both the baseline and the alternatives.

### 1. LaWS Modeling Results

Figure 26 displays the LaWS alternative compared to the baseline model for a swarm of eight UAVs attacking a DDG. The implementation of LaWS improves the baseline model by improving the CIWS base accuracy and cycle time by 20 percent. Changing these parameters improves the CIWS performance in the baseline model for both long and medium ranges. The team assumed that accuracy would be increased because the laser would fire in a perfectly straight line, and therefore increased CIWS accuracy by 20 percent in the model. The team assumed that cycle time would be reduced because battle damage assessment would depend less on the time it takes for the bullets to reach the target. As such, the cycle time was reduced by 20 percent in the model. Adding this alternative to the baseline model resulted in a 1.3 percent decrease in average UAV hits on the DDG.

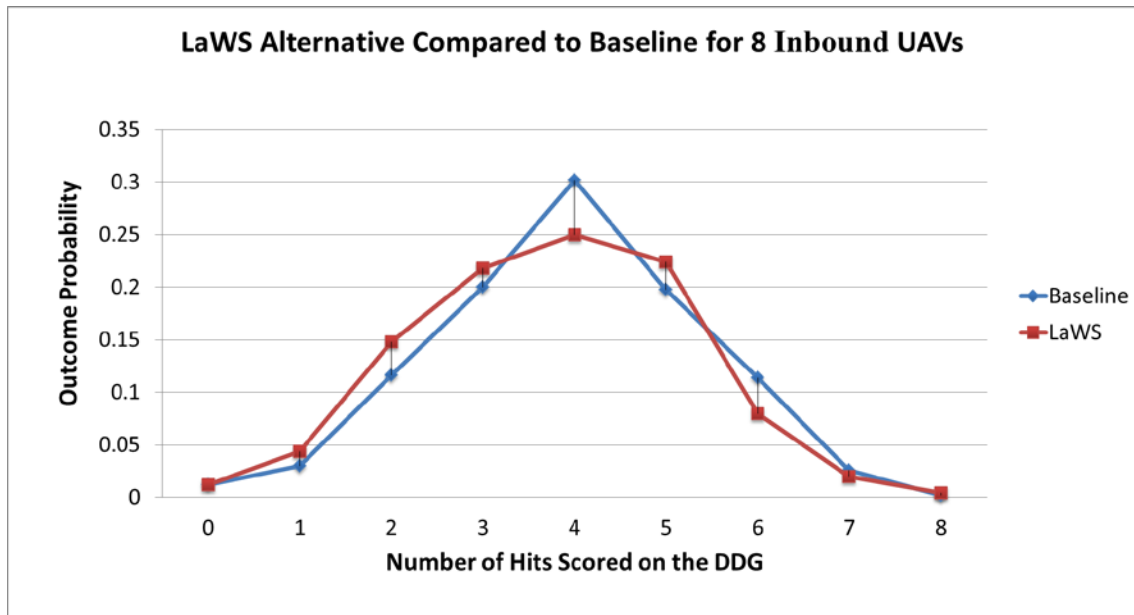


Figure 26: LaWS Alternative Results



## 2. UAV Radar Decoy Modeling Results

Figure 27 displays the UAV-launched radar decoy alternative compared to the baseline model for a swarm of eight UAVs attacking a DDG. The implementation of the UAV radar decoy improves the baseline model by increasing the amount of Harpy UAVs destroyed at long range. Because the Fire Scout would launch its multiple radar decoys once a single UAV is detected, it has the capability to engage multiple Harpy UAVs, including ones that have not yet been detected. Provided at least one UAV is detected, the radar decoy has a 0.4 chance of seducing each inbound Harpy UAV in the model. This alternative assumes that the ship's UAV, the Fire Scout, would use its onboard sensors to detect enemy UAVs, so it also causes the long range probability of detect to increase by 0.1 in the model. Adding this alternative to the baseline model results in a 26.4 percent decrease of average UAV hits scored on the DDG.

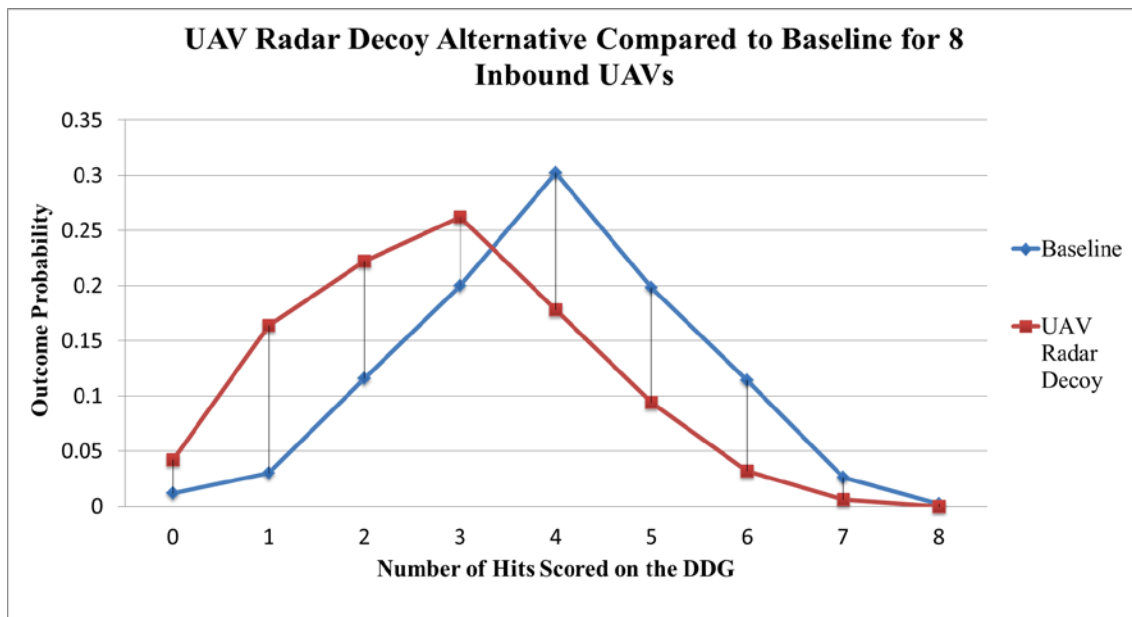


Figure 27: UAV Radar Decoy Alternative Results

### 3. Fire Scout Modeling Results

Figure 28 displays the Fire Scout alternative compared to the baseline model for a swarm of eight UAVs attacking a DDG. The Fire Scout's onboard weapons are assumed to be about as effective as the small arms mounts on the DDG. Given that the baseline small arms have a limited firing window as the UAVs close with the ship, the implementation of the Fire Scout alternative in the model lengthens that firing window by doubling the number of opportunities for shooting down UAVs at short and medium ranges. Due to its onboard sensor capabilities, the Fire Scout also causes the long range probability of detect to increase by 0.1 in the model. Based on the model, the Fire Scout is one of the unfavorable implementations, as it has minimal impact through modeling results. Adding this alternative to the baseline model results in a 2.1 percent decrease in average UAV hits scored on the DDG.

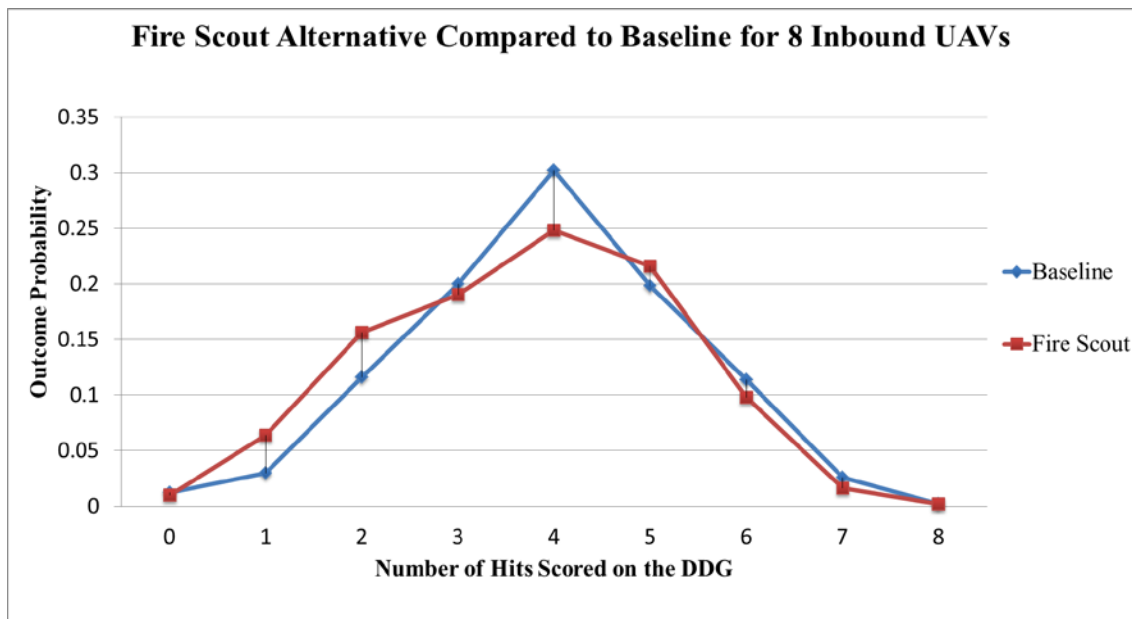


Figure 28: Fire Scout Alternative Results

#### 4. Additional CIWS Modeling Results

Figure 29 displays the additional CIWS alternative compared to the baseline model for a swarm of eight UAVs attacking a DDG. Because in the DRM the incoming UAVs attack the front of the DDG, only one CIWS can fire at the UAVs for the baseline DDG. Assuming that two CIWS mounts can fire at the UAVs simultaneously in this alternative, the model implementation of additional CIWS mounts doubles the number of opportunities for shooting down UAVs with the CIWS at long and medium ranges. Based on the model, the CIWS is one of the favorable implementations as it has significant impact through modeling results. Adding this alternative to the baseline model results in a 34.5 percent decrease in the number of average UAV hits scored on the DDG.

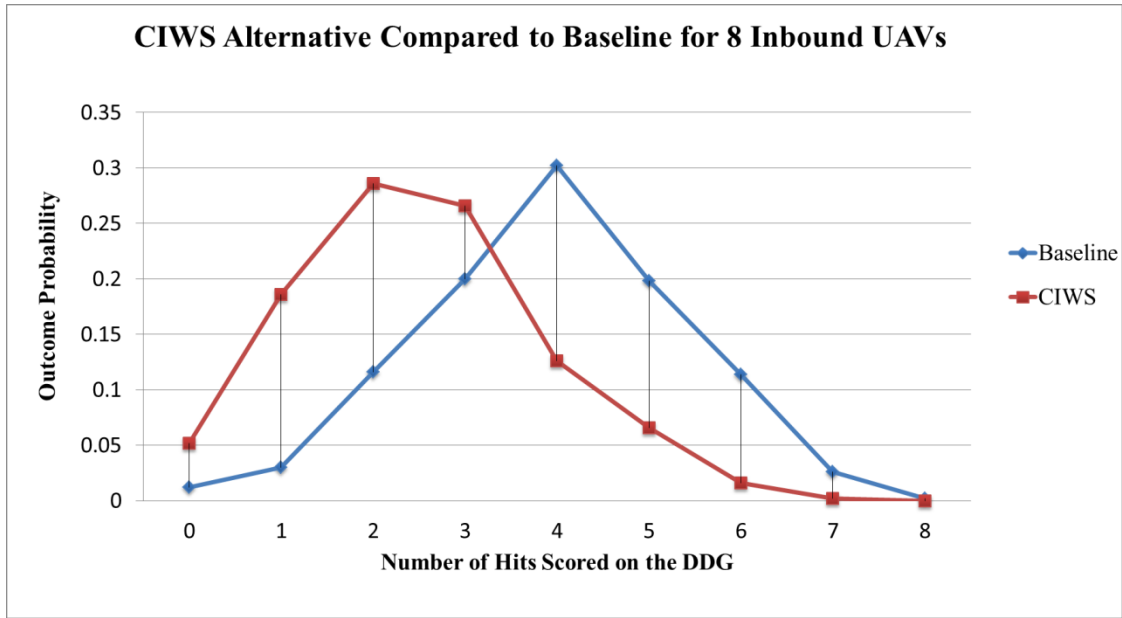
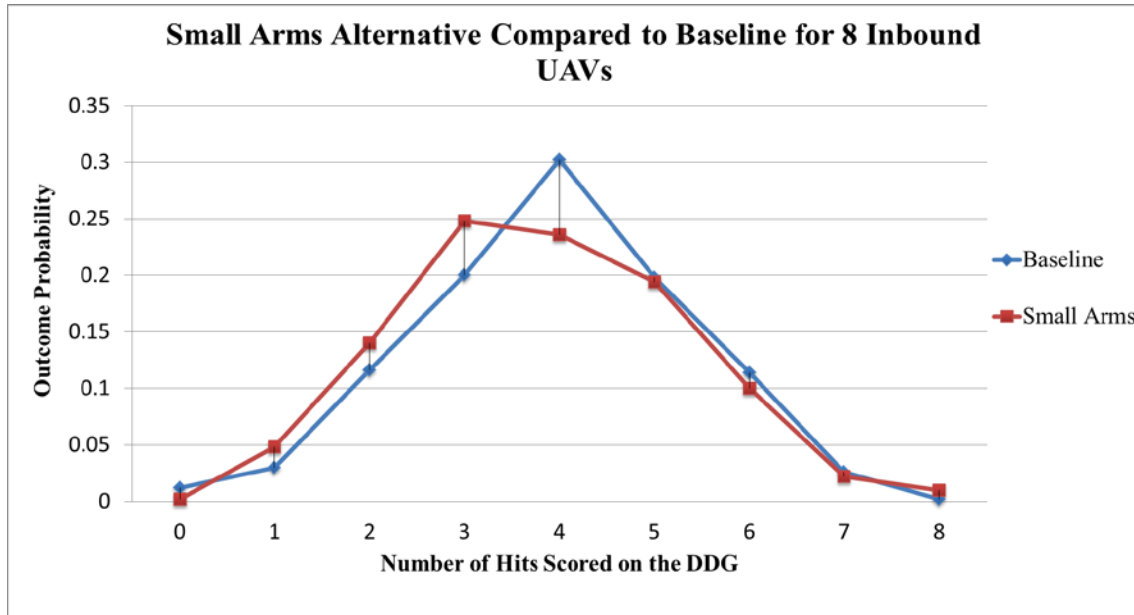


Figure 29: Additional CIWS Alternative Results

#### 5. Additional Small Arms Modeling Results

Figure 30 displays the additional small arms alternative compared to the baseline model for a swarm of eight UAVs attacking a DDG. The implementation of additional small arms improves the baseline model by doubling the number opportunities for shoot-

ing down UAVs with the small arms at short and medium ranges. Based on the model, the additional small arms is an unfavorable implementation, as it has minimal impact as indicated by modeling results. Adding this alternative to the baseline model results in a 4.0 percent decrease of average UAV hits scored on the DDG.

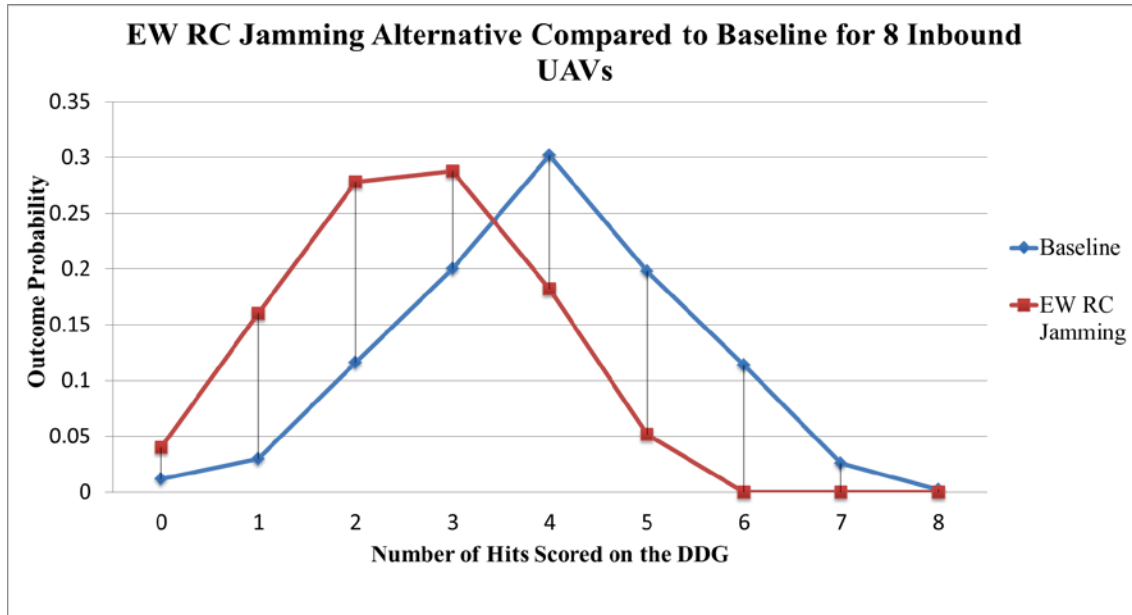


**Figure 30: Additional Small Arms Alternative Results**

## 6. Electronic Warfare (EW) Jamming Modeling Results

Figure 31 displays the electronic warfare jamming alternative compared to the baseline model for a swarm of eight UAVs attacking a DDG. This alternative is capable of having a 360 degree bubble of coverage which defeats multiple RC UAV threats by disrupting communication signals. Because the DDG would activate its jamming field before its approach to port, it has the capability to engage multiple RC UAVs, including ones that have not yet been detected. The jammer in the model has a 0.7 chance of disrupting each inbound RC UAV's control enough to cause it to miss the DDG. When the electronic warfare jamming alternative is added, there is some overlap between the targets it affects and the targets shot down by the small arms, because the small arms operators do not know which RC UAVs have been successfully jammed. Based on the model, the electronic warfare jamming alternative is one of the favorable implementations, as it

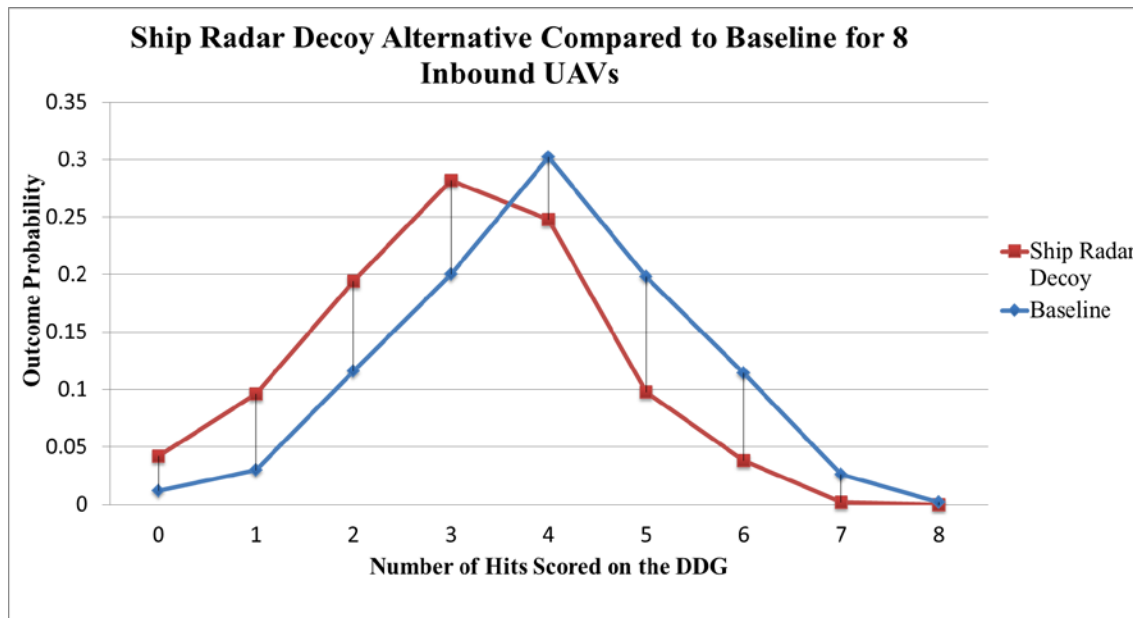
has significant impact as indicated in the modeling results. Adding this alternative to the baseline model results in a 32.7 percent decrease of average UAV hits scored on the DDG.



**Figure 31: Electronic Warfare Jamming Alternative Results**

## 7. Ship Based Radar Decoy Modeling Results

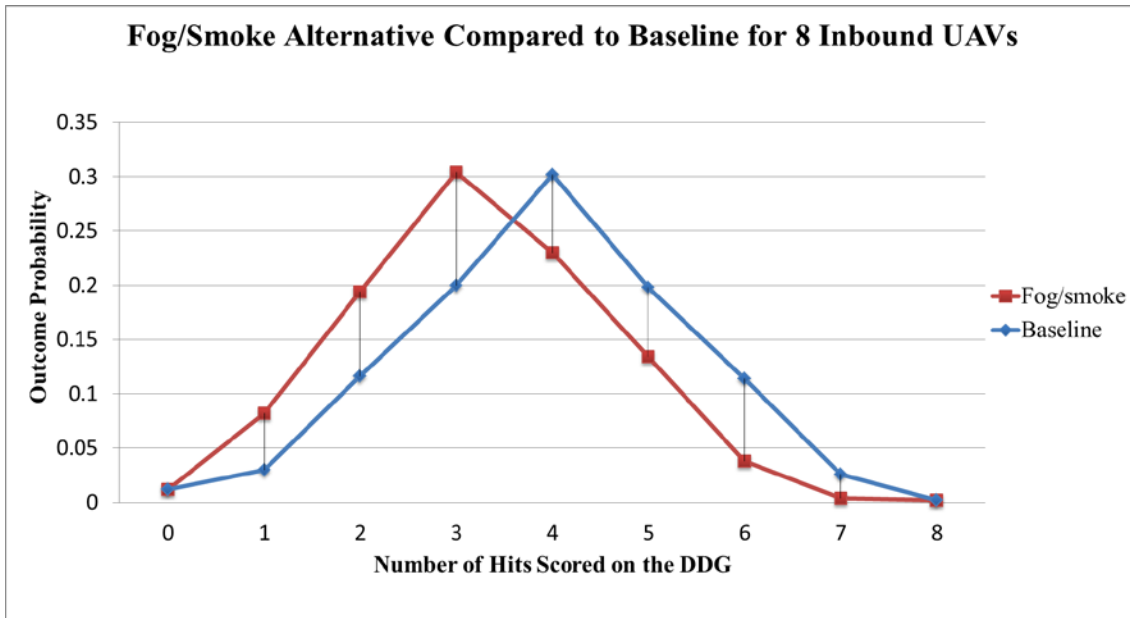
Figure 32 displays the ship-launched radar decoy alternative compared to the baseline model for a swarm of eight UAVs attacking a DDG. The implementation of the ship radar decoy improves the baseline model by increasing the amount of UAVs destroyed at short range. Because the ship would launch multiple radar decoys once a Harpy UAV is detected at short range, it has the capability to engage multiple Harpy UAVs, including ones that have not yet been detected. Provided at least one Harpy UAV is detected and survives the medium-range defensive systems, the radar decoy has a 0.4 chance of seducing each inbound Harpy UAV in the model. Adding this alternative to the baseline model results in a 20.0 percent decrease of the average UAV hits scored on the DDG.



**Figure 32: Ship Based Radar Decoy Alternative Results**

## 8. Smokescreen Modeling Results

Figure 33 displays the smokescreen alternative compared to the baseline model for a swarm of eight UAVs attacking a DDG. The implementation of the smokescreen improves the baseline model by reducing the probability of RC UAVs being able to collide with the ship. Since the RC UAVs are being guided visually from afar, executing this alternative would make it difficult for the operator to successfully guide the RC UAV to impact the DDG. Provided that at least one UAV is detected at short range, the smokescreen in the model has a 0.5 chance of causing each incoming RC UAV to miss the ship. Because the smoke would also interfere with target tracking for the DDG's small arms, this alternative causes the short range small arms accuracy to be reduced from 0.15 to 0.05 in the model. Adding this alternative to the baseline model results in a 15.0 percent decrease of average UAV hits scored on the destroyer.



**Figure 33: Smokescreen Alternative Results**

## 9. Modeling Results Summary

To compare each alternative to the baseline model, the average number of “UAV Hits” was calculated from the results. In the model, “UAV Hits” are described as UAVs that were either undetected, unsuccessfully neutralized, or a combination of both that also successfully collide with the ship. Average results of 500 simulations were recorded to compare the baseline model with each alternative. Table 38 assesses the “Baseline Average UAV Hits” and each “Alternative Average UAV Hits” for the model. These two variables are utilized to calculate the percent decrease for each alternative. For example, EW RC Jamming yields a total of 32.7 percent decrease from the original baseline model.

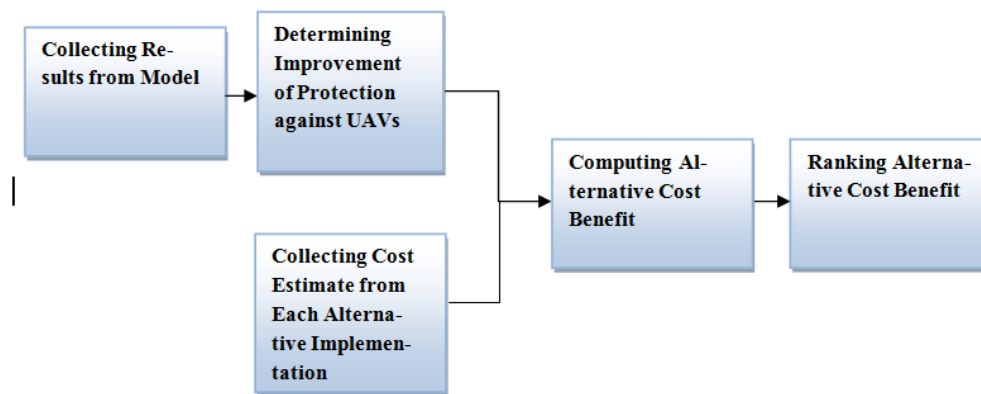
**Table 38: Alternative Results**

Alternative	Alternative Average UAV Hit	Percent Decrease	Standard Deviation
Baseline	3.82	0.0	1.47
EW RC Jamming	2.57	32.7	1.2
Additional CIWS	2.5	34.5	1.34
Ship Radar Decoy	3.05	20.0	1.4
Fog/Smoke	3.24	15.0	1.34

Alternative	Alternative Average UAV Hit	Percent Decrease	Standard Deviation
UAV Radar Decoy	2.81	26.4	1.47
LaWS	3.76	1.3	1.46
Additional Small Arms	3.62	4.0	1.45
Fire Scout	3.73	2.1	1.5

## B. COST BENEFIT ANALYSIS

The purpose of the cost benefit analysis is to rank the alternatives by their cost effectiveness to find the best alternatives for protecting the DDG against UAV swarm attacks. The cost benefit analysis is a process starting with obtaining the required information, and ending with ranking the alternatives to find the ones with the highest cost effectiveness, as shown in Figure 34: Cost Benefit Analysis Process.



**Figure 34: Cost Benefit Analysis Process**

Computing alternatives' cost benefit is the key step in the cost benefit analysis process. For each alternative, it involves finding the improvement in model effectiveness divided by the cost of that alternative. Effectiveness is measured for both the baseline and each alternative by the number of UAV hits scored on the DDG as obtained from an average of 500 runs in the simulation model. The improvement of average number of UAV hits scored on the DDG is determined by computing the difference between the baseline hits and the alternative hits, as shown in Equation 1.



### Equation 1

*Improvement of average number of UAV hits =*

*Baseline average number of UAV hits – Alternative average number of UAV hits*

With the alternatives' cost estimates obtained from alternative section, the cost benefit for each alternative is computed by dividing the improvement of average number of UAV hits by the cost estimate, as shown in Equation 2. The higher result indicates the better cost benefit and higher ranking.

### Equation 2

$$\text{Alternative cost benefit} = \frac{\text{Improvement of average number of UAV hits}}{\text{Cost estimate}}$$

Table 39 shows the summary of the alternatives as discussed in the Alternatives Sections and the results from the simulation model. Based on the alternative capabilities, some of the alternatives can only be effective against only either RC UAVs or the Harpy. The RC UAV Jamming EW and the Smoke Screen are only effective against the RC UAVs. The ship radar decoy and the UAV radar decoy are only effective against the Harpy. The RC UAV jamming EW, the smoke screen, the ship radar decoy, and the UAV radar decoy are also categorized as non-lethal or soft-kill weapon systems. These non-lethal or soft-kill weapon systems are used to neutralize the UAVs and to divert the impact of UAV attacks from the DDG. On the other hand, the other alternatives such as CIWS, LaWS, small arms mounts, and the Fire Scout with APKWS are effective against the RC UAVs and the Harpy. These alternatives are categorized as lethal or hard-kill weapon systems. These lethal or hard-kill weapon systems destroy or eliminate the UAVs before their impact could cause any structural damage to the DDG or casualties in its crew. Most of the alternatives have medium effective ranges against UAV swarm attacks except the Small Arms Mounts Alternative, Ship-Based Radar Decoy, and the Smoke Screen Alternative, which have short effective ranges, and the UAV-Launched Radar Decoy, which is effective at long range.

**Table 39: Summary of Alternatives Performance**

Alternatives	Cost per Fleet (\$M)	Cost per DDG(\$M)	Range	UAV Types	Kill Type	Number of UAV Hits
Baseline	\$0	\$0.0	Medium	RC UAV and Harpy	Hard	3.82
CIWS	\$816	\$13.2	Medium	RC UAV and Harpy	Hard	2.50
EW: RC Jammer	\$1,028	\$16.6	Medium	RC UAV	Soft	2.57
Fire Scout/APKWS	\$2,121	\$34.2	Medium	RC UAV and Harpy	Hard	3.73
LAWS	\$2,379	\$38.4	Medium	RC UAV and Harpy	Hard	3.77
Ship-Based Radar Decoy	\$1,018	\$16.4	Short	Harpy	Soft	3.05
Small Arms Mounts	\$362	\$5.8	Short	RC UAV and Harpy	Hard	3.66
Smoke Screen	\$2,014	\$32.5	Short	RC UAV	Soft	3.24
Fire Scout/Radar Decoy	\$2,218	\$35.8	Long	Harpy	Soft	2.81

As the results from the simulation model show, the CIWS alternative (which doubles the number of CIWS mounts) has the smallest UAVs hits with 2.5, and the RC UAV jamming alternative has nearly identical results, with 2.56 hits scored on the DDG. The LaWS alternative has the highest UAVs hits of 3.76 and is joined by the Fire Scout with APKWS alternative (3.73 hits) and the additional small arms mounts alternative (3.66 hits) in having very little reduction in hits from the baseline (3.81 hits). However, the results from the cost benefits analysis process would determine which alternative would be the choice for implementation in terms of reduction of UAVs hits per million dollars spent. Table 40 is the summary of the results from the cost benefit analysis. Applying the cost benefit process as described earlier, the CIWS Alternative, the RC UAV Jamming EW, and the Ship-Based Radar Decoy Alternative are the top three most cost effective. Meanwhile, the LaWS, the smoke screen and the Fire Scout with APKWS System Alternatives are the least cost effective.

**Table 40: Summary of Cost Benefit Analysis for Individual Alternatives**

Alternatives	Number of UAV hits	Improvement by Number of UAV hits	Cost per Fleet (\$M)	Cost per DDG (\$M)	Benefit (UAV hits/\$M)	Most Cost Effective Ranking
Baseline	3.82	0.00	\$0	\$0.0	NA	NA
CIWS	2.50	1.32	\$816	\$13.2	<b>0.100</b>	1
EW: RC Jammer	2.57	1.25	\$1,028	\$16.6	<b>0.075</b>	2
Ship-Based Radar Decoy	3.05	0.76	\$1,018	\$16.4	<b>0.046</b>	3
Fire Scout/Radar Decoy	2.81	1.01	\$2,218	\$35.8	<b>0.028</b>	4
Small Arms Mounts	3.66	0.15	\$362	\$5.8	<b>0.026</b>	5
Smoke Screen	3.24	0.57	\$2,014	\$32.5	<b>0.018</b>	6
Fire Scout/APKWS	3.73	0.08	\$2,121	\$34.2	<b>0.002</b>	7
LAWS	3.77	0.05	\$2,379	\$38.4	<b>0.001</b>	8

However, each alternative has its own limitations. The RC UAV Jamming EW has medium effective range and is only effective against RC UAVs. However, the RC UAV Jamming EW requires no reloading, which provides constant protection against UAVs. The ship-based radar decoy is only effective against the Harpy, not the RC UAV. The CIWS has a large footprint, which means it requires significant space for integrating additional units on the DDG. The small arms mounts has short effective ranges and poor accuracy. The UAV-launched radar decoy can only be implemented when the ship already has its own UAV, which leads to high cost for implementation; the cost for this alternative in Table 40: Summary of Cost Benefit Analysis for Individual Alternatives includes the cost for the Fire Scout in addition to the decoy launcher integration. The LaWS and Fire Scout with APKWS system are the least effective against UAVs and expensive to implement. Moreover, the small arms mounts, the ship-based radar decoy and CIWS require reloading between usages. Therefore, the combination of the alternatives would be essential to fill the capability gaps of the individual alternatives.

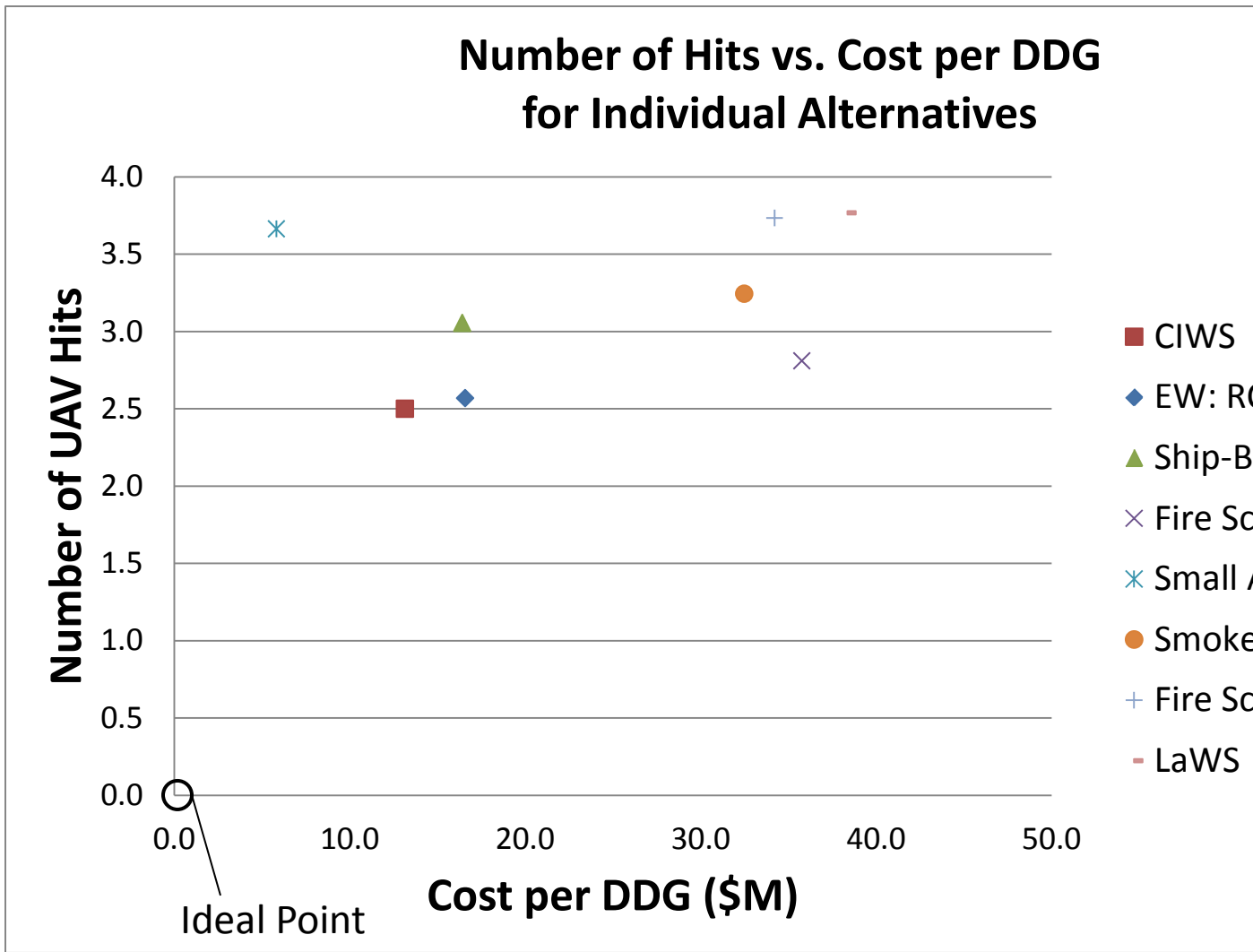
The top three cost effective alternatives were chosen for the combinations. These were chosen because they had the highest cost benefit of the 8 alternatives. Their capabilities can mutually fill in the capability gaps. Particularly, the combination of the RC UAV Jamming EW and the ship-based radar would provide full DDG protection against RC UAVs and the Harpy. Table 41 shows the results of the combinations. Although there are

only 4 combinations in Table 41, there are 7 entries to show the individual results comparatively. The top three combinations, based on marginal benefit, are actually not all combinations. Coming in at Number 1 is the CIWS by itself. Number 2 is the combination of CIWS and EW. Number 3 is EW by itself. The reason that the marginal benefit for the combination of CIWS and EW is better than the EW by itself is because the CIWS has such a high marginal benefit compared to EW.

**Table 41: Summary of Cost Benefit Analysis for Combination of Alternatives**

Combination of Alternatives	Number of UAV hits	Improvement by Number of UAVs hits	Cost per Fleet (\$M)	Cost per DDG (\$M)	Benefit (UAV hits/\$M)	Most Cost Effective Ranking
Baseline	3.82	0.00	\$0	\$0.0	NA	NA
CIWS	2.50	1.32	\$816	\$13.2	<b>0.100</b>	1
CIWS + EW: RC Jammer	1.56	2.25	\$1,844	\$29.7	<b>0.076</b>	2
EW: RC Jammer	2.57	1.25	\$1,028	\$16.6	<b>0.075</b>	3
EW: RC Jammer + Ship decoy	1.69	2.13	\$2,046	\$33.0	<b>0.064</b>	4
CIWS + Ship decoy	2.01	1.80	\$1,834	\$29.6	<b>0.061</b>	5
CIWS + EW: RC Jammer+ Ship-Based Radar Decoy	1.12	2.70	\$2,862	\$46.2	<b>0.058</b>	6
Ship-Based Radar Decoy	3.05	0.76	\$1,018	\$16.4	<b>0.046</b>	7

Figure 35 is a scatter plot that shows the individual alternatives' average number of hits scored on the DDG versus cost based on the 8 inbound UAVs over the 500 simulation runs. The best alternative for the money would be the CIWS, given that it has the highest reduction in hits scored on the DDG per dollar. Looking at the plot, the Small Arms Mounts alternative barely improves the number of hits from the baseline (3.82 versus 3.66, for a difference of 0.15), so is not worth consideration. The CIWS, EW, and Ship-Based Radar Decoy alternatives are in the lower left-hand corner of the remaining alternatives. Of these, the CIWS has fewer resulting hits and costs the least. The EW alternative results in the lowest number of hits after the CIWS, and has close to the same cost as the Ship-Based Radar Decoy. The Ship-Based Radar Decoy has slightly worse performance (with a higher number of hits) than the next best Fire Scout-Launched Radar Decoy, but costs far less than it and the other remaining alternatives. This scatter plot was based off of the data from Table 40.



**Figure 35: Cost per DDG vs. Number of Hits for Individual Alternatives**

Figure 36 shows the same as Figure 35 but for the combinations of alternatives. The results are a lot more linear here, with better performance as more money is spent, making it more difficult to narrow exactly what configuration would be best for the DDG. It will ultimately come down to how much funding is available to spend on the DDG upgrade. Because each of the three alternatives under consideration have approximately the same cost (\$13.2 million U.S. dollars to \$16.6 million U.S. dollars per DDG), the decision first depends upon how many alternatives fit within the budget. With a single upgrade to the DDG fleet, the CIWS makes the most sense, reducing the number of UAV hits to 2.5 for \$816 million U.S. dollars (\$13.2 million U.S. dollars per DDG). If funds

are available for two upgrades, the combination of the CIWS and EW Jammer upgrades is most cost effective, reducing the UAV hits to 1.56 for a total cost of \$1844 million U.S. dollars (\$29.7 million U.S. dollars per DDG). If additional funding is allocated toward improving UAV defense, then it makes sense to upgrade the DDG with the CIWS, EW Jammer, and Ship-Based Radar Decoy alternatives, reducing the UAV hits to 1.12 for a total cost of \$2862 million U.S. dollars (\$46.2 million U.S. dollars per DDG).

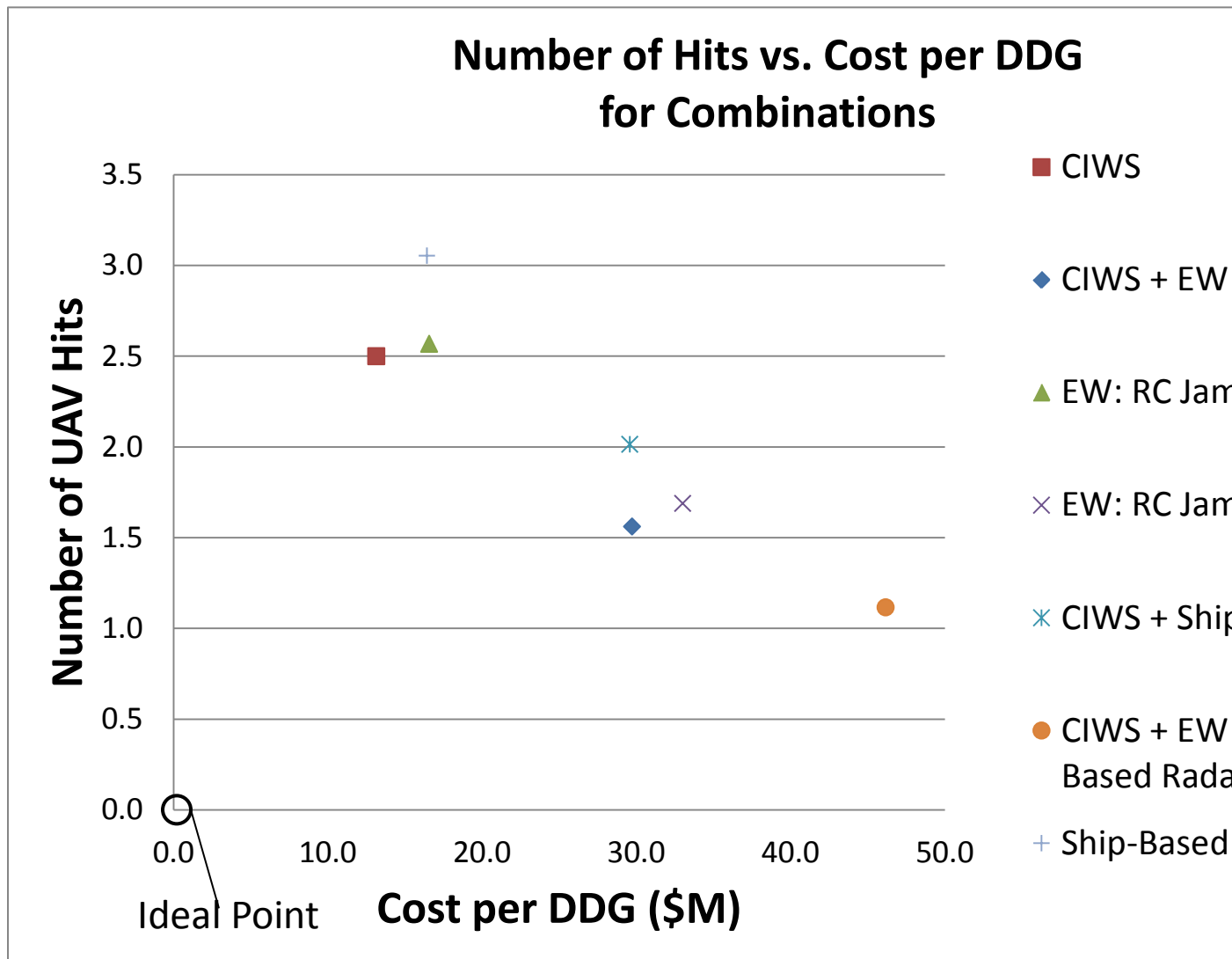


Figure 36: Cost per DDG vs. Number of Hits for Combinations

The recommendation also depends on factors other than available funds. The cost estimate assumed that the ship-launched radar decoy would require its own launcher rather than being able to make use of the DDG's existing decoy launchers. If it could make use of the DDG's existing launchers, or if existing decoys could be modified to be effective against the Harpy UAV, then this would lower the price of that alternative significantly, making it even more attractive. Similarly, if DDGs obtain their own UAVs, such as the Fire Scout, to fulfill some other mission need, then it could be a cheap, effective alternative to equip that UAV with radar decoys.

THIS PAGE INTENTIONALLY LEFT BLANK



## VII. CONCLUSIONS AND RECOMMENDATIONS

The objectives of this project were to analyze the current USN destroyer baseline capabilities for defending against UAVs, identify the capability gaps, generate alternatives for UAV defense, and use systems engineering techniques to determine the most cost-effective options for defending against UAV threats.

In this report, it was discussed that a DDG may be threatened by a swarm of UAVs acting as IEDs, while operating in a littoral setting on a mission to assist expeditionary strike groups. This report assessed how well the current combat systems of the DDG can defend the ship against a swarm of UAVs. It was concluded that when attacked by a swarm of 8 UAVs, the most probable outcome was that four UAVs were able to impact the ship, thus concluding that the DDG is not able to adequately defend against a swarm of UAVs. In order to determine what factors would assist in the DDG's defensive capabilities, a sensitivity analysis was performed. The sensitivity analysis demonstrated that improving the sensors is not as effective as making weapon system improvements.

In concurrence with the results of the sensitivity analysis, system alternatives focused on neutralizing UAVs were identified. The alternatives identified were assessed based on cost, risk, and model improvements. It was concluded from this analysis that adding additional CIWS mounts, incorporating an electronic warfare jammer, and installing radar decoy launchers on the DDG are the most cost effective alternatives. These alternatives work well together in combinations and when examined via modeling, their use indicates they would reduce the modeled number of UAV hits on the DDG as additional alternatives are installed.

There are many opportunities for further research in the area of UAV swarm defense. During the research for the current scenario, the modeling activities conducted by the team generated mostly top level ideas rather than precise predictions, and this could be improved through several model modifications. First, due to the classification of information concerning DDG capabilities, the model could be run in a classified environment using classified numbers for inputs such as probability of detection for sensor systems and probability of kill for weapon systems. The model could also be tailored for a

specific type of UAV, based on the threat assessment for a specific region. Instead of considering all DDG sensor systems as a whole, the model could provide increased granularity by modeling each sensor system individually; rather than just providing the total number of detections at a given range, the improved model could provide the number of detections by each detection system. Finally, the model could incorporate battle damage for both hits to the incoming UAVs by the DDG and the hits scored on the DDG by the UAVs. The model could thus show how hits from different weapon systems would have different probabilities of shooting down the UAVs, how different types of UAVs could better withstand hits, and how the number of UAV hits required to seriously damage or sink a DDG depends on the size of the UAV's explosive payload.

Because this project involved a fairly specific scenario, further research could involve broadening the scenario. The scenario could include the threat of UAV attack swarms carrying missiles rather than the suicide IED threat examined in this project. The scenario could also consider a broader range of factors such as weather, number of friendly ships nearby, and location; a DDG in port and a DDG in open water would have different defensive systems available.

Once an alternative is selected for more detailed investigation, user feedback would provide more pertinent information regarding the refinement of the suitability risks. Alternatives could also benefit from more refined cost estimates. Prototype testing could validate an alternative's performance in the model, and lower the risk of implementing that alternative on a DDG.

The results of this report may be limited in their application. For example, several limiting assumptions had to be made accommodate for the use of unclassified information on the threat and on the DDG's capabilities. However, if the proper inputs are applied, then the process and techniques utilized in this project, including the model file itself, can be used to guide a more in-depth analysis. It is hoped that by doing a more in-depth analysis, the most economical solution can be found in order to protect the DDG against a swarm of UAVs in accordance with the standards of today's warfighter.

## APPENDIX A - TEAM ORGANIZATION

### A-1 TEAM ORGANIZATION

The Crane Team is formed by eight students. Table A-42 contains a list of the names and contact information for the eight team members. All members of the team are collocated at NAVSEA Crane and are enrolled in the Naval Postgraduate School (NPS) Masters of Science in Systems Engineering (MSSE) program.

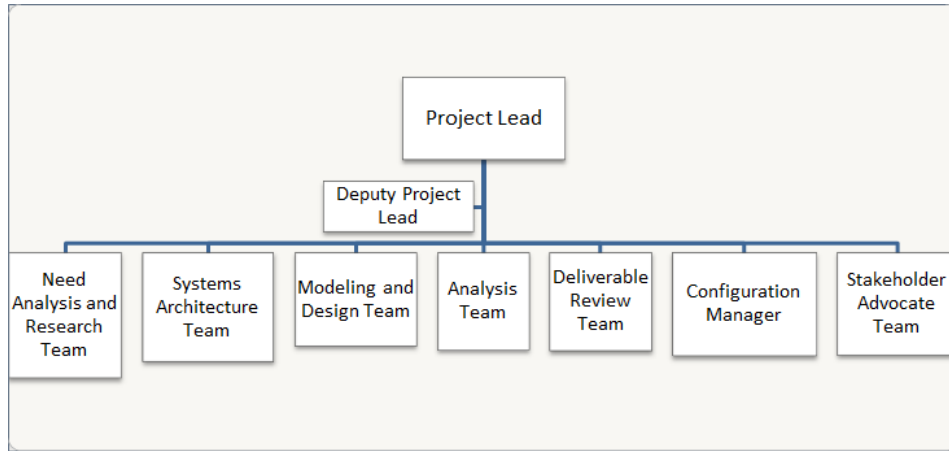
**Table A-42: Team Crane Members**

Name	Work Telephone	Work E-mail
Balbuena, Demostenes	(812) 854-6150	demostenes.balbuena@navy.mil
Casserly, Michael	(812) 863-3117	michael.j.casserly@saic.com
Dickerson, Brandon	(812) 854-4877	brandon.dickerson@navy.mil
Graves, Stephen	(812) 854-8325	stephen.j.graves@navy.mil
Maldonado, Vince	(812) 854-1460	vicente.maldonado@navy.mil
Pandya, Bhavisha	(812) 854-1555	bhavisha.pandya@navy.mil
Pham, Loc	(812) 854-6261	loc.pham@navy.mil
Sanders, James	(812) 854-1030	james.sanders2@navy.mil

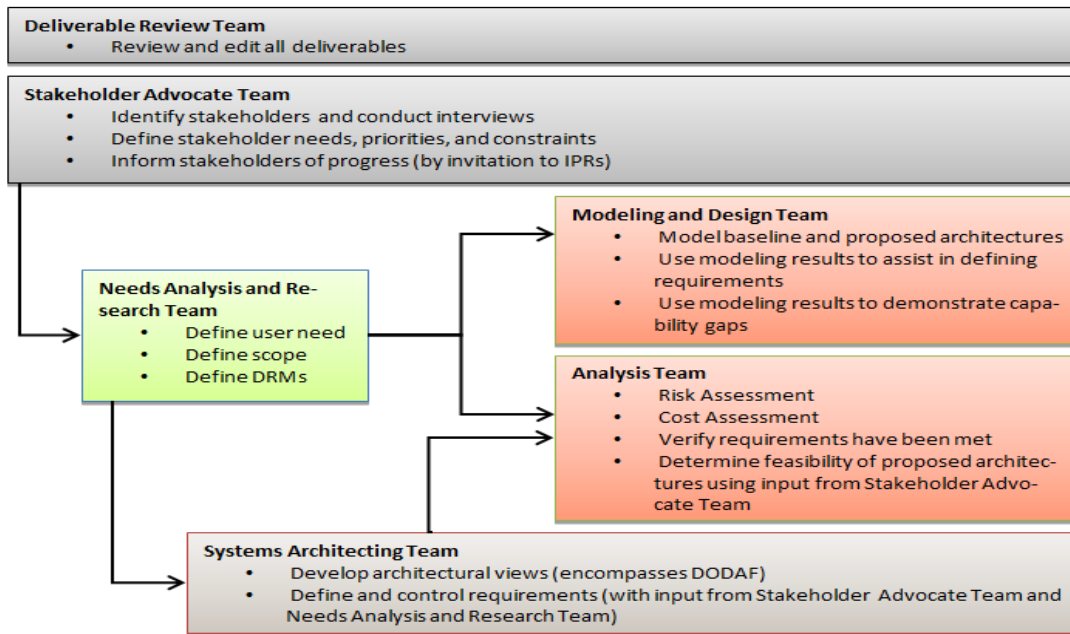
### A-2 TEAM STRUCTURE

The team organization, as shown in Figure A-37, consists of six integrated product teams (IPTs) along with a project lead, deputy project lead, and configuration manager. The IPTs include the Stakeholder Advocate Team, Need Analysis and Research Team, Systems Architecture Team, Modeling and Design Team, Analysis Team, and Deliverable Review Team. IPTs were chosen in order to maintain tasking flexibility and to promote teamwork. Not all of the IPTs are in existence throughout the duration of the project. The IPTs were created when the need arose and members of the IPT gradually joined other IPTs as tasking was completed. In this way, flexibility was maintained by increasing or decreasing the number of members on each team in order to meet the scheduled deliverables outlined in the Integrated Master Schedule (IMS). However, in order to accommodate for an iterative process throughout the project, at least one team member was responsible for maintaining and updating previous deliverables of all IPTs. Because team members are a part of a small team throughout the duration of the project,

effective communication and relationships were established, promoting teamwork. Responsibilities held by the positions outlined in Figure A-34: Team Organization is described below. Figure A-38 is a qualitative representation of when the IPTs are formed and disbanded with respect to each other.



**Figure A-37: Team Organization**



**Figure A-38: IPT Qualitative Timeline**

### **A-2.1 PROJECT LEAD**

The project lead is primarily responsible for developing an Integrated Master Scheduled (IMS) and directing all team activities for the duration of the project. In addition, the project lead is responsible for leading team meetings.

### **A-2.2 DEPUTY PROJECT LEAD**

The Deputy Project Lead assists the Project Lead in his duties. In addition, the Deputy Project Lead is responsible for developing the team organization and assessing that there is a proper work distribution among the organization in order to promote work efficiency and compliance with the IMS. The Deputy Project Lead also schedules team meetings.

### **A-2.3 CONFIGURATION MANAGER**

The configuration manager is responsible for maintaining the format and structure of the final report. Some of these responsibilities include maintaining a table of contents, ensuring proper number of tables and figures, assisting in integrating individual sections into the overall report, maintaining a list of references, and other tasks as needed.

### **A-2.4 STAKEHOLDER ADVOCATE TEAM**

The Stakeholder Advocate Team is in existence for the entire duration of the project. At the start of the project, the team is responsible for identifying all stakeholders involved, conducting stakeholder interviews, and documenting the stakeholders' needs and concerns which will be utilized by the other IPTs. The Stakeholder Advocate Team uses their analysis and input from the Needs Analysis and Research Team to translate the Stakeholder's need into a collection of system requirements. Members of the Stakeholder Advocate Team may join other IPTs; however, at least one team member remains on the Stakeholder Advocate Team for the duration of the project and is responsible for establishing and maintaining communication with the stakeholders. The Stakeholder Advocate

Team is required to document their findings and produce applicable deliverables for use in the final report.

### **A-2.5 NEEDS ANALYSIS AND RESEARCH TEAM**

The Needs Analysis and Research Team is created at the start of the project, but is reduced as team members are required for tasking on other IPTs. The main responsibilities of the Needs Analysis and Research Team are to clearly define the user need and establish the scope of the project. The Needs Analysis and Research Team accomplishes these responsibilities by utilizing input from the Stakeholder Advocate Team, researching current capabilities, and establishing the design reference mission (DRM). The Needs Analysis and Research Team is required to document their findings and produce applicable deliverables for use in the final report. At least one previous member of the Needs Analysis and Research Team is responsible for updating the deliverables as needed throughout the duration of the project.

### **A-2.6 SYSTEMS ARCHITECTURE TEAM**

The Systems Architecture Team is created when the need and scope of the project has been identified by the Needs Analysis and Research Team. The Systems Architecture Team is responsible for developing the applicable architectural views, generating and maintaining requirements, and ensuring traceability of requirements. The Systems Architecture Team utilizes the research conducted by the Needs Analysis and Research Team, ensures compliance with Stakeholders through the input of the Stakeholder Advocate Team, and maintains a working relationship with the Modeling and Design Team. The Systems Architecture Team is required to document their findings and produce applicable deliverables for use in the final report. At least one previous member of the Systems Architecture Team is responsible for updating the deliverables as needed throughout the duration of the project.

### **A-2.7 MODELING AND DESIGN TEAM**

The Modeling and Design Team is created concurrently with the Systems Architecture Team. The Modeling and Design Team works closely with the Systems Architecture Team in order to assist in requirements generation by modeling the threat scenarios defined by the Needs Analysis and Research Team. In addition, the Modeling and Design Team uses inputs from the Needs Analysis and Research Team to identify a capability gap and to design potential solutions. The Modeling and Design Team is required to document their findings and produce applicable deliverables for use in the final report. At least one previous member of the Modeling and Design Team is responsible for updating the deliverables as needed throughout the duration of the project.

### **A-2.8 ANALYSIS TEAM**

The Analysis Team assesses the solutions identified by the Modeling and Design Team for their respective costs, associated risks, and effectiveness against the UAV threat (resulting from the Modeling and Design Team's model), verifying that the established requirements have been met. The Analysis Team then takes input from the Stakeholder Advocate Team to recommend which solutions may or may not be feasible and verify that the stakeholders' needs have been met. The Cost and Risk Analysis Team is required to document their findings and produce applicable deliverables for use in the final report. At least one previous member of the Cost and Risk Analysis Team is responsible for updating the deliverables as needed throughout the duration of the project.

### **A-2.9 DELIVERABLE REVIEW TEAM**

The Deliverable Review Team is responsible for reviewing and editing all deliverables to ensure proper grammar has been used and that the content is consistent with all other deliverables. The team members' roles are outlined in Table A-43.

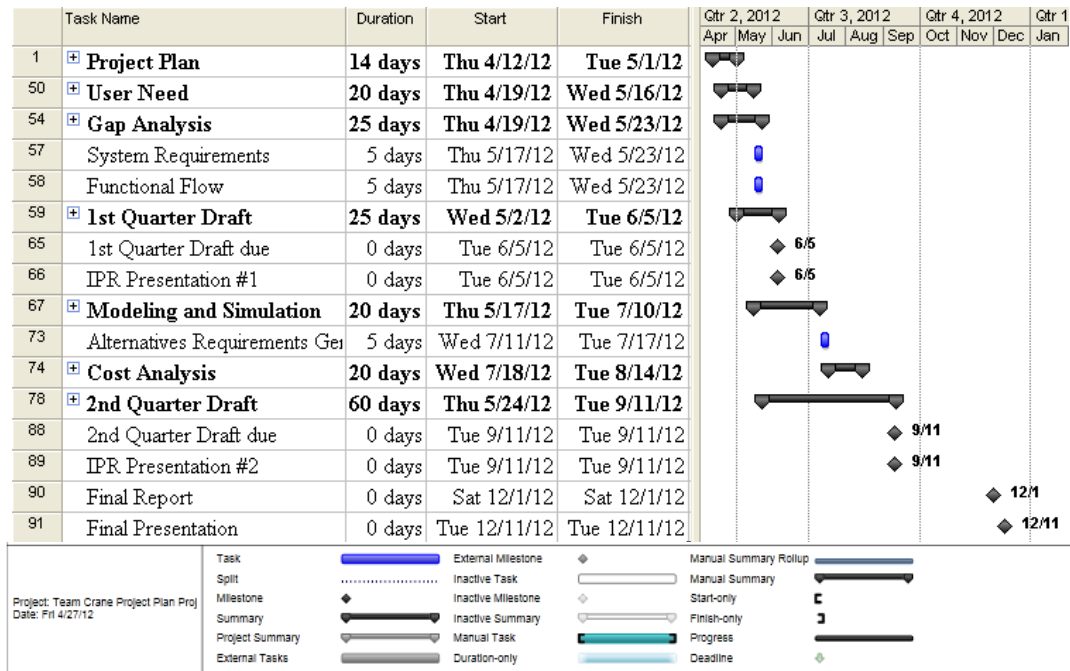
**Table A-43: Team Member Roles**

Name	Role
Balbuena, Demostenes	Systems Architecture Team Lead, Stakeholder Advocate Team Member
Casserly, Michael	Project Lead, Deliverable Review Team Lead, Stakeholder Advocate Team Member, Modeling and Design Team Member
Dickerson, Brandon	Systems Architecture Team Member, Need Analysis and Research Team Member, Deliverable Review Team Member
Graves, Stephen	Deputy Project Lead, Need Analysis and Research Team Lead, Systems Architecture Team Member
Maldonado, Vince	Modeling and Design Team Lead, Need Analysis and Research Team Member
Pandya, Bhavisha	Analysis Team Lead, Need Analysis and Research Team
Pham, Loc	Stakeholder Advocate Team Lead, Analysis Team Member
James Sanders	Configuration Manager, Stakeholder Advocate Team Member, Analysis Team Member



## APPENDIX B - SCHEDULES AND MILESTONES

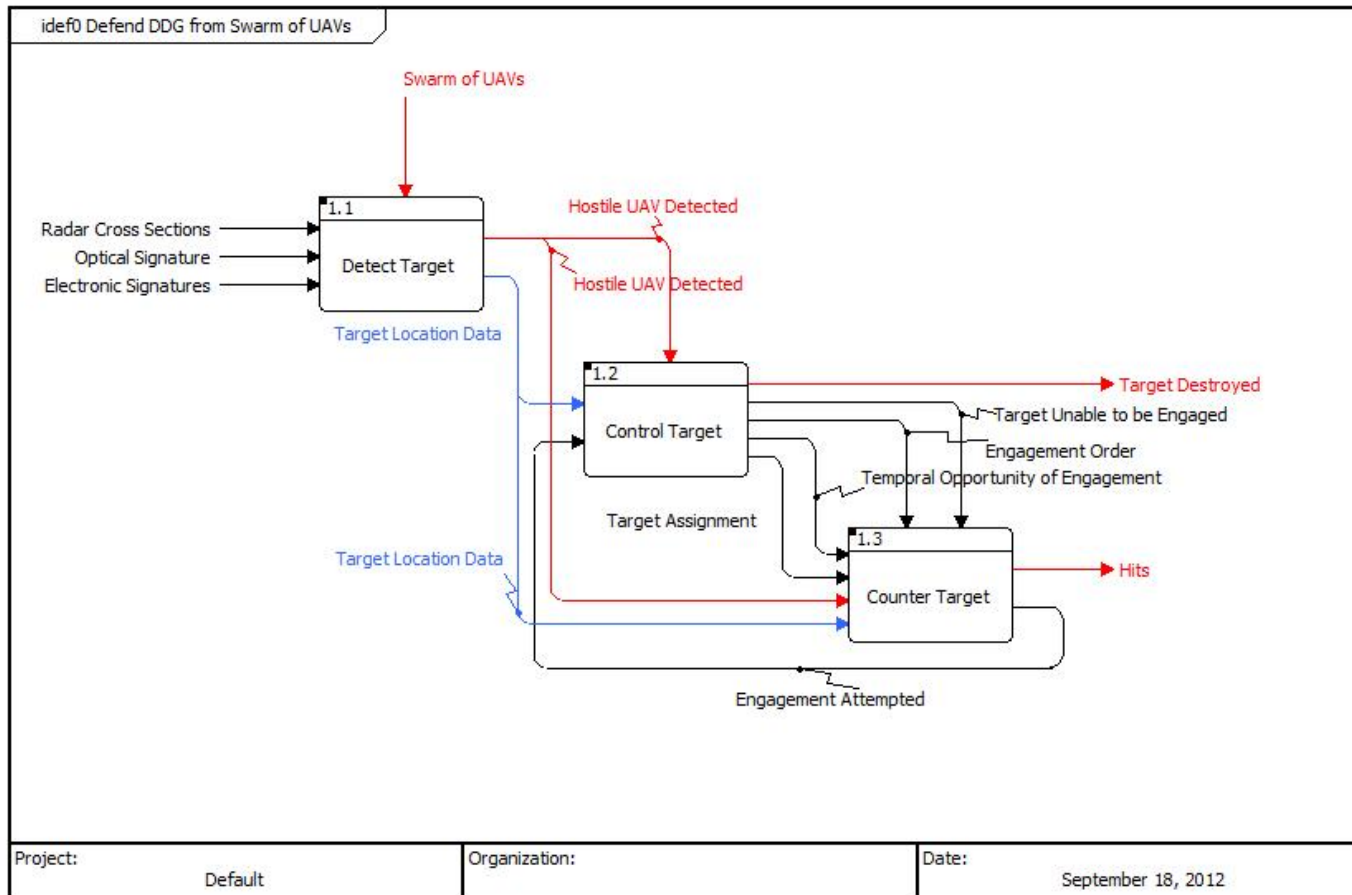
A timeframe of three quarters are specified for the completion of the capstone project. During this time the group has specific tasks and duties to complete associated with the project. Important milestones have been developed by the group for optimal efficiency and time management. The first major milestone is the Project Plan which consists of the team organization, stakeholders, Systems Engineering process, and other preliminary project topics. The next major milestones consist of the first and second drafts. These allow the group to create and update the document which becomes the final report. The final report is the culmination of all of the completed work and the final presentation is created from the final report. Figure B-39 shows the Gantt chart specifying all the important milestones and their associated dates.



**Figure B-39: Gantt chart**

THIS PAGE INTENTIONALLY LEFT BLANK

## APPENDIX C - SYSTEM ARCHITECTURE



**Figure C-40: OV-5 IDEF0 Defend DDG from Swarm of UAVs (Level 1)**

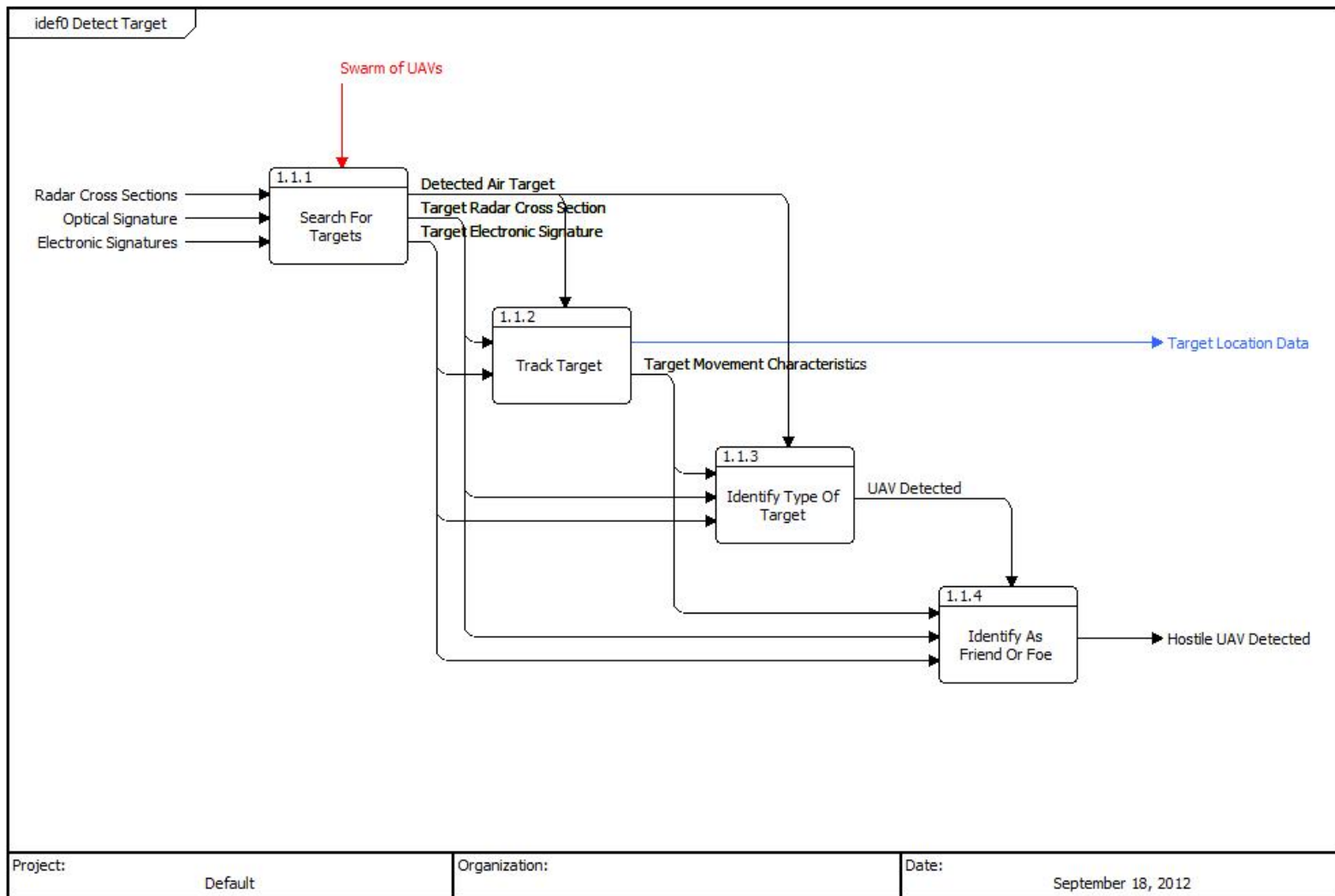


Figure C-41: OV-5 IDEF0 Detect Target (Level 2)

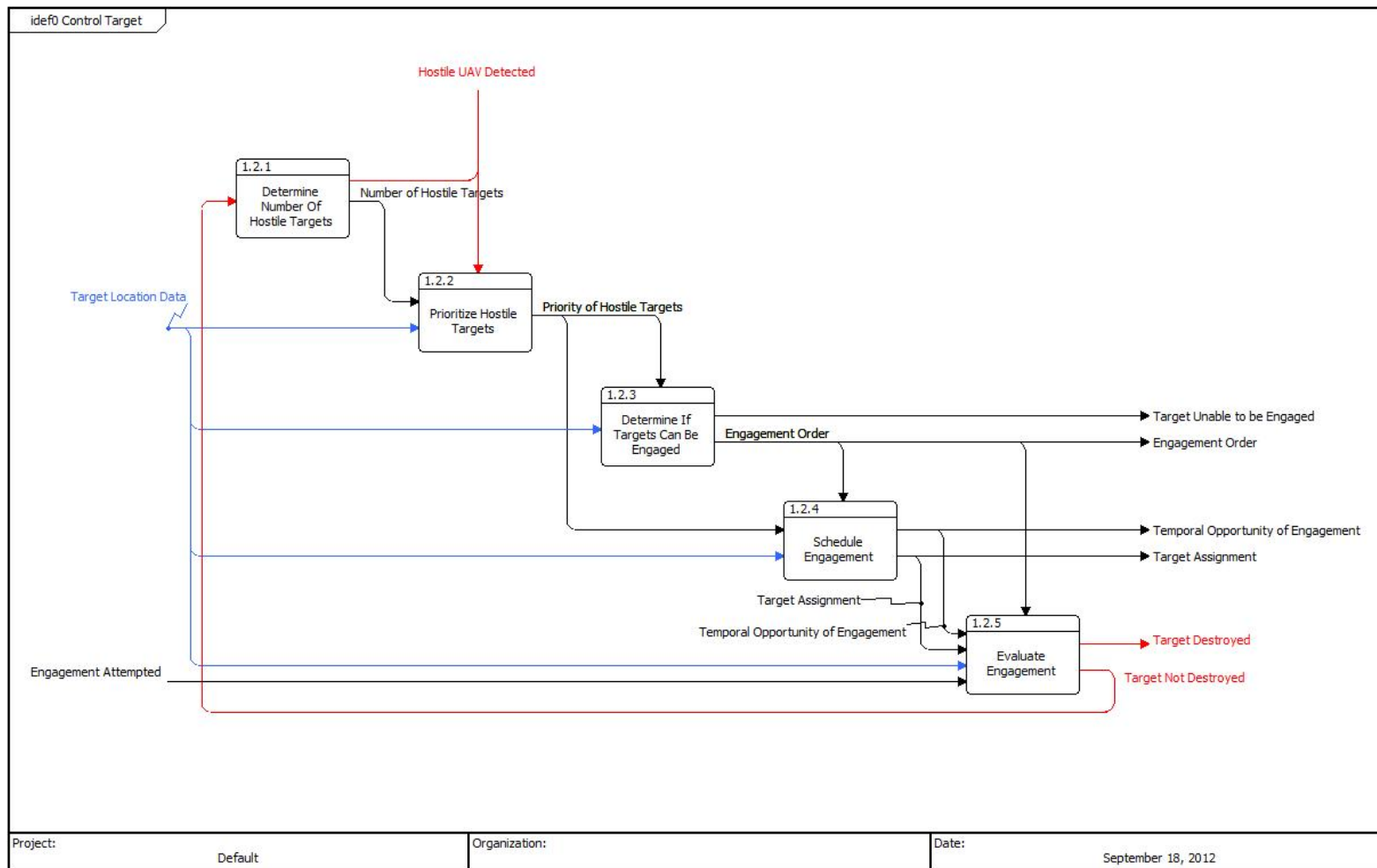


Figure C-42: OV-5 IDEF0 Control Target (Level 2)

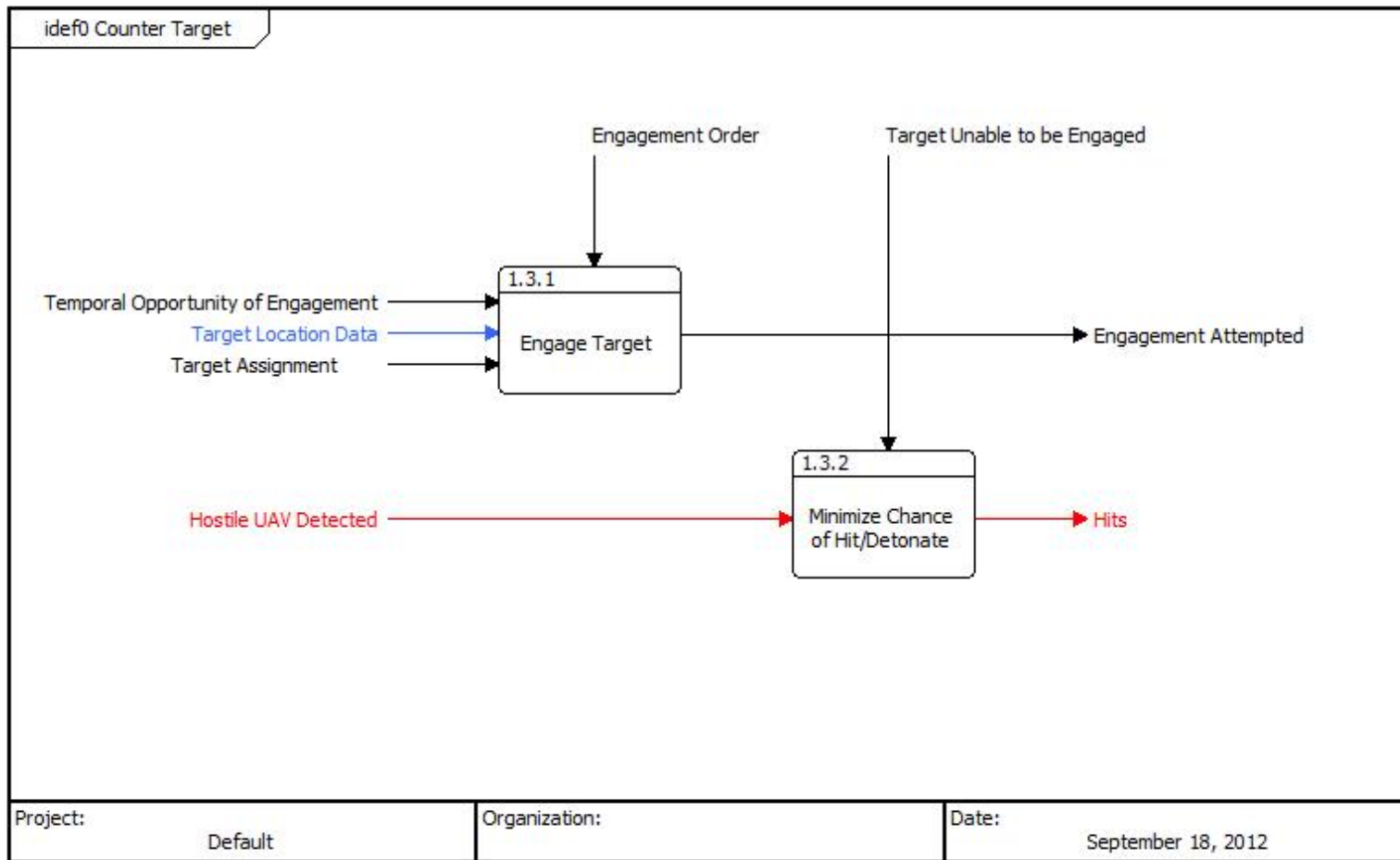


Figure C-43: OV-5 IDEF0 Counter Target (Level 2)

## APPENDIX D - SYSTEM REQUIREMENTS

**Table D-44: System Requirements**

Section	Item	Description	Type	Refined by	Specifies
1	Required Capability	Onboard Destroyer Protection System (ODPS) provides commanders with dynamic situational awareness (SA) and destroyer protection from UAV swarm attacks.	Capability Gap		Function 1 Protect AEGIS Destroyer from a UAV Threat
1.1	Threat detection	The ODPS requires a layered network of radars, and sensors capabilities enabling persistent, all weather, multi-discipline situational awareness to enhance the Commander's situational awareness (SA) and to provide threat information for threat identification and threat engagement. The ODPS will be capable to detect threats with large radar cross section (RCS), small RCS, and deceptive radar threats (stealth).	nil	Requirement 1.1.1 Radar Cross Section (RCS)	
1.1.1	Radar Cross Section (RCS)	The ODPS detection system shall be able to detect UAVs with a RCS greater than 0.5 m <sup>2</sup> .	Capability Gap		Function 1 Protect AEGIS Destroyer from a UAV Threat Function 1.1 Detect UAV Swarm Function 1.3 Track Target
1.1.2	Range	The ODPS detection system shall be able to detect threats at X meters (m) with probability of X%.	Capability Gap		Function 1.1 Detect UAV Swarm Function 1.1.1 CIWS Detect Function Function 1.1.2 SPY-1 Detect

Section	Item	Description	Type	Refined by	Specifies
1.1.3	Detection Altitude	The ODPS detection system shall be able to detect threats from the water surface up to an altitude of 3,000 meters.	nil		Function 1.1 Detect UAV Swarm Function 1.3.1 Computer Tracking System
1.1.4	Treat Speed	The ODPS detection system shall be able to detect UAVs flying from X Km per hour (km/h) to 250 km/h.	Capability Gap		Function 1.1 Detect UAV Swarm Function 1.3 Track Target
1.1.5	Spectrum	The ODPS detection system shall be able to detect the threat data link in full spectrum with frequency ranging from 0MHz to 25,000MHz*.	nil		Function 1.3.1 Computer Tracking System
1.1.6	Threat Detection Location	The ODPS detection system shall be able to locate the direction of attacks with respect to the DDG location.	nil		Function 1.1.3 Lookout Detect Function 1.2 Prioritize Target Function 1.3 Track Target Function 1.3.1 Computer Tracking System
1.1.7	Number of threats detection	The ODPS detection system shall be able to detect up to 10 threats in real time.	Capability Gap		Function 1.1 Detect UAV Swarm
1.2	Threat identification	The ODPS will assist in the conduct of threat identification by facilitating real time spectrum data in target identification through the differentiation between friend and foe, combat identification, and/or positive identification. The ODPS also supports precision lethal, nonlethal, and cooperative engagement through automated dissemination and enhanced data distribution under the severest conditions in full spectrum operations.	nil		



Section	Item	Description	Type	Refined by	Specifies
1.2.1	Friend or Foe Identification	The ODPS identification system shall be able to identify detection UAVs as small cross section aerial vehicles at X meters (m) with probability of X%.	nil		Function 1.1 Detect UAV Swarm Function 1.3 Track Target Function 1.3.1 Computer Tracking System
1.2.2	ID Information	The ODPS identification system shall provide all near real-time targets' ID information as: GPS location. Velocity. Distance to DDG. Direction of movement.	nil		Function 1.3.1 Computer Tracking System
1.3	Protection	The ODPS will enable 180 degree spherical protection umbrella from current and future threats by detecting, identifying, and lethal and nonlethal engagement.	nil		
1.3.1	Presetting command	The ODPS C&D subsystem shall allow users to enter mission doctrine statement to dictate autonomous responses to given specified stimuli.	nil		Function 1.4 Engage Threat Function 1.4.2 Small Arms Engage
1.3.1.1	Presetting Command	The ODPS C&D subsystem shall allow users to enter mission doctrine statement to dictate autonomous response to a given specified stimulus.	Capability Gap		
1.3.1.2	Threat Tracking	The ODPS C&D subsystem shall be able to create, manage, and display the threat tracking information.	nil		Function 1.3 Track Target Function 1.3.1 Computer Tracking System
1.3.1.3	Threat Evaluation	The ODPS C&D shall be able to evaluate the priority of threat in order to assist the DDG command in making decision to assign appropriate method of engagement.	Capability Gap		Function 1.2 Prioritize Target Function 1.2.1 Distance Prioritization Function 1.3 Track Target Function 1.3.1 Computer Tracking System

Section	Item	Description	Type	Refined by	Specifies
1.3.1.4	DDG Weapon Assignment		Capability Gap		
1.3.1.5	Command and Control (C2) Interface	The ODPS C&D subsystem shall be able to interface with the current C2 system.	nil		Function 1.3.1 Computer Tracking System Function 1.4 Engage Threat
1.3.2.1	Display Information	The ODPS display system shall provide the DDG command threat identification information as well as threat tracking in real time	Capability Gap		
1.3.2.2	Display resolution	The ODPS display system shall have color display resolution at the quality of 1080p HD quality.	Capability Gap		
1.4	Threat Engagement	The ODPS will have the capability of lethal engagement, and nonlethal engagement to eliminate threats. The lethal engagement is the usage of lethal weapon system such as missiles, and gun systems. The nonlethal engagement is the usage of electronic attack (EA) system such as jammer.	nil		
1.4.1	Engagement Range	The ODPS shall have the "Kill" range at the minimum of 500 meters.	Capability Gap		
1.4.2	Probability of Kill	The ODPS shall have a probability of kill of X% at X meters.	nil		Function 1 Protect AEGIS Destroyer from a UAV Threat Function 1.4 Engage Threat Function 1.4.2 Small Arms Engage Function 1.4.3 SLQ-32 Engage

Section	Item	Description	Type	Refined by	Specifies
1.4.3	Engagement Method	The ODPS shall have lethal (weapon systems) and nonlethal (Electronic Attack) mean of engagement.	nil		Function 1.4 Engage Threat Function 1.4.1 CIWS Engage Function 1.4.2 Small Arms Engage Function 1.4.3 SLQ-32 Engage
1.5	Battle Command/C2	ODPS enhance commanders' situational awareness by providing near-real-time relevant information within a collaborative C2 environment based on federated data standards and schema, an open architecture, and common control standards. Commanders should also have the flexibility to selectively extend network transport connectivity to units or battle space via ODPS situation awareness (SA). This network extension capability enables information and knowledge connectivity to the tactical edge while operating in degraded or interrupted network environments.	nil		
1.5	Operational Environment	The system shall meet the requirements of the following environmental test criteria as outlined in MIL-STD-810G:	Capability Gap		Function 1 Protect AEGIS Destroyer from a UAV Threat
1.5.1	Operational Temperature	The ODPS system shall be operable without degradation to specified system performance throughout the temperature range of -20°C to +60°C to meet the MIL-STD-810G Method 501.5 (high temperature) and the MIL-STD-810G Method 502.5 (low temperature).	Capability Gap		
1.5.2	Storage Temperature	The ODPS system shall meet the requirements of this specification after prolonged non-operating storage at any temperature within the range of -28°F (-33°C) to +160°F (+71°C) to meet the MIL-STD-810G Method 501.5 (high temperature) and the MIL-STD-810G Method 502.5 (low temperature).	Capability Gap		

Section	Item	Description	Type	Refined by	Specifies
1.5.3	Humidity	The ODPS system shall initialize and operate when exposed to humidity levels typical of the required operational environment to which the system will be subjected to meet the MIL-STD-810G Method 507.5.	nil		
1.5.4	Salt Fog	The system shall have the resistance to the effects of a salt atmosphere primarily to meet the MIL-STD-810G Method 509.5.	nil		
1.5.5	Rain and Blowing Rain	The system shall initialize and operate during and after exposure to rain and blowing rain to meet the MIL-STD-810G Method 506.5.	nil		
1.5.6	Low Pressure (Altitude)	The system shall be transportable (non-operating) in military aircraft at altitudes of up to 40,000 feet to meet the MIL-STD-810G Method 500.5	Capability Gap		
1.5.7	Shock	The system, in its intended mounted operational configuration, shall be subjected to the shock profiles of tactical environment. In transport mode, the system shall be subjected to the shocks encountered in transportation. The system shall meet the MIL-STD-810G Method 516.6	Capability Gap		
1.5.8	Vibration	The system shall be subjected to the vibration to meet the MIL-STD-810G Method 514.6.	Capability Gap		
1.5.9	Icing/Freezing Rain	The system shall be subjected to ice buildup due to rain, drizzle, fog or splash to meet the MIL-STD-810G Method 521.3.	Capability Gap		
1.5.10	Ballistic Shock	The system shall be subjected to the ballistic shock to meet the MIL-STD-810G Method 522.1	Capability Gap		
1.6	Sustainment	The ODPS must conduct or support sustainment tasks, functions, and missions of: supply, distribution, and services, from home station to forward deployed locations, including the sea base.	nil		
1.6.1	System Operational Availability (Ao)	The ODPS system shall have the operational availability (Ao) of X%	nil		Function 1 Protect AEGIS Destroyer from a UAV Threat

## APPENDIX E - TECHNOLOGY READINESS LEVEL DESCRIPTION

**Table E-45: TRL Descriptions (From (ASD(R&E)) 2011)**

<b>TRL</b>	<b>Definition</b>	<b>Description</b>	<b>Supporting Information</b>
1	Basic principles observed and reported.	Lowest level of technology readiness. Scientific research begins to be translated into applied research and development (R&D). Examples might include paper studies of a technology's basic properties.	Published research that identifies the principles that underlie this technology. References to who, where, when.
2	Technology concept and/or application formulated.	Invention begins. Once basic principles are observed, practical applications can be invented. Applications are speculative, and there may be no proof or detailed analysis to support the assumptions. Examples are limited to analytic studies.	Publications or other references that outline the application being considered and that provide analysis to support the concept.
3	Analytical and experimental critical function and/or characteristic proof of concept.	Active R&D is initiated. This includes analytical studies and laboratory studies to physically validate the analytical predictions of separate elements of the technology. Examples include components that are not yet integrated or representative.	Results of laboratory tests performed to measure parameters of interest and comparison to analytical predictions for critical subsystems. References to who, where, and when these tests and comparisons were performed.
4	Component and/or breadboard validation in a laboratory environment.	Basic technological components are integrated to establish that they will work together. This is relatively "low fidelity" compared with the eventual system. Examples include integration of "ad hoc" hardware in the laboratory.	System concepts that have been considered and results from testing laboratory-scale breadboard(s). References to who did this work and when. Provide an estimate of how breadboard hardware and test results differ from the expected system goals.

<b>TRL</b>	<b>Definition</b>	<b>Description</b>	<b>Supporting Information</b>
5	Component and/or breadboard validation in a relevant environment.	Fidelity of breadboard technology increases significantly. The basic technological components are integrated with reasonably realistic supporting elements so they can be tested in a simulated environment. Examples include “high-fidelity” laboratory integration of components.	Results from testing laboratory breadboard system are integrated with other supporting elements in a simulated operational environment. How does the “relevant environment” differ from the expected operational environment? How do the test results compare with expectations? What problems, if any, were encountered? Was the breadboard system refined to more nearly match the expected system goals?
6	System/subsystem model or prototype demonstration in a relevant environment.	Representative model or prototype system, which is well beyond that of TRL 5, is tested in a relevant environment. Represents a major step up in a technology’s demonstrated readiness. Examples include testing a prototype in a high-fidelity laboratory environment or in a simulated operational environment.	Results from laboratory testing of a proto-type system that is near the desired configuration in terms of performance, weight, and volume. How did the test environment differ from the operational environment? Who performed the tests? How did the test compare with expectations? What problems, if any, were encountered? What are/were the plans, options, or actions to resolve problems before moving to the next level?
7	System prototype demonstration in an operational environment.	Prototype near or at planned operational system. Represents a major step up from TRL 6 by requiring demonstration of an actual system prototype in an operational environment (e.g., in an air-craft, in a vehicle, or in space).	Results from testing a prototype system in an operational environment. Who performed the tests? How did the test compare with expectations? What problems, if any, were encountered? What are/were the plans, options, or actions to resolve problems before moving to the next level?
8	Actual system completed and qualified through test and demonstration.	Technology has been proven to work in its final form and under expected conditions. In almost all cases, this TRL represents the end of true system development. Examples include developmental test and evaluation (DT&E) of the system in its intended weapon system to determine if it meets design specifications.	Results of testing the system in its final configuration under the expected range of environmental conditions in which it will be expected to operate. Assessment of whether it will meet its operational requirements. What problems, if any, were encountered? What are/were the plans, options, or actions to resolve problems before finalizing the design?
9	Actual system proven through successful mission operations.	Actual application of the technology in its final form and under mission conditions, such as those encountered in operational test and evaluation (OT&E). Examples include using the system under operational mission conditions.	OT&E reports.

## LIST OF REFERENCES

- “ALE-47.” The World’s Choice for Countermeasures Dispensing Systems. 2008.  
[http://www.baesystems.com/cs/groups/public/documents/document/mdaw/mdm3/~edisp/baes\\_019967.pdf](http://www.baesystems.com/cs/groups/public/documents/document/mdaw/mdm3/~edisp/baes_019967.pdf) (accessed September 29, 2012).
- “Department Of the Navy Fiscal Year (FY) 2010 Budget Estimates.” Other Procurement, Navy Budget Activity 4. May 2009.  
[http://www.finance.hq.navy.mil/fmb/10pres/OPN\\_BA4\\_BOOK.pdf](http://www.finance.hq.navy.mil/fmb/10pres/OPN_BA4_BOOK.pdf) (accessed October 5, 2012).
- “Department Of The Navy Fiscal Year (FY) 2010 Budget Estimates.” Aircraft Procurement, Navy Vol. II: Budget Activity 5. May 2009.  
[http://www.finance.hq.navy.mil/FMB/10pres/APN\\_5\\_Justification\\_Book.pdf](http://www.finance.hq.navy.mil/FMB/10pres/APN_5_Justification_Book.pdf) (accessed October 5, 2012).
- “Harpy Air Defense Suppression System.” Defense Update Magazine. March 4, 2006.  
<http://defense-update.com/directory/harpy.htm> (accessed October 1, 2012).
- “Jane’s Radar And Electronic Warfare Systems.” GENeric eXpendable (GEN-X), 2007.  
<http://articles.janes.com/articles/Janes-Radar-and-Electronic-Warfare-Systems/GENeric-eXpendable-GEN-X-United-States.html> (accessed 2012)
- (Aeroweb), Aerospace and Defense. MQ–8 Fire Scout (MQ-8B/C). September 28, 2012.  
<http://www.bga-aeroweb.com/Defense/MQ-8-Fire-Scout.html#Budget> (accessed 2012).
- (ASD(R&E)), Assistant Secretary of Defense for Research and Engineering. “Technology Readiness Assessment (TRA) Guide.” acq.osd.mil. May 13, 2011.  
<http://www.acq.osd.mil/chieftechnologist/publications/docs/TRA2011.pdf> (accessed October 2, 2012).
- “Lockheed Martin’s Advanced Countermeasure Decoy Launch System Plays Integral Role in LCS Layered Ship Self-Defense.” n.d.  
<http://www.lockheedmartin.com/us/ms2/features/110408-got-your-back.html> (accessed September 8, 2012).
- “USS Freedom: Littoral Combat Ship Contract Award Announced.” December 29, 2010.  
<http://www.public.navy.mil/surfor/lcs1/Pages/LittoralCombatShipContractAwardAnnounced.aspx> (accessed September 20, 2012).
- Admiral Clark, V. (2002, October). Sea Power 21. Retrieved April 27, 2012, from United States Navy: <http://www.navy.mil/navydata/cno/proceedings.html>

- Aeroweb. DoD Spending, Procurement and RDT&E: FY 2011 + Budget for FY 2012 and FY 2013. n.d. <http://www.bga-aeroweb.com/Defense/MQ-8-Fire-Scout.html> (accessed 2012).
- ALE-47. June 6, 2010. <http://en.citizendium.org/wiki/ALE-47> (accessed September 28, 2012).
- Army Guide. 2008. <http://www.army-guide.com/eng/product4229.html>.
- BAE Systems. BAE Adding Laser-Guided Rocket to Northrop Fire Scout UAV. 2012. <http://www.thenewnewinternet.com/2012/09/18/bae-adding-laser-guided-rocket-to-northrop-fire-scout-uav-roy-rumbaugh-comments/> (accessed 2012).
- BAE Systems. baesystems.com. 2011. [http://www.baesystems.com/cs/groups/public/documents/document/mdaw/mdqx/~edisp/baes\\_027609.pdf](http://www.baesystems.com/cs/groups/public/documents/document/mdaw/mdqx/~edisp/baes_027609.pdf).
- Barrie, Allison. "War Games." 2012. <http://www.foxnews.com/tech/2012/08/16/navy-new-advanced-precision-kill-weapon-system-adds-laser-precision-to-ordinary/> (accessed 2012).
- Blanchard, B. S., & Fabrycky, W. J. (2011). *System Engineering and Analysis*. Upper Saddle River: Prentice Hall.
- Center, Defense Technical Information. Exhibit R-2, RDT&E Budget Item Justification: PB 2013 Air Force. 2011. [http://www.dtic.mil/descriptivesum/Y2013/AirForce/stamped/0604602F\\_5\\_PB\\_2013.pdf](http://www.dtic.mil/descriptivesum/Y2013/AirForce/stamped/0604602F_5_PB_2013.pdf) (accessed 2012).
- Cooke, Gary W. Gary's U.S Infantry Weapon Reference Guide. February 25, 2010. <http://www.inetres.com/gp/military/infantry/index.html#mg>.
- Cubic. 2012. <http://www.cubic.com/LinkClick.aspx?fileticket=HRk0YmVb3hA%3D&tabid=298> (accessed 2012).
- Daily, Defense Industry. APKWS II: Laser-Guided Hydra Rockets in Production at Last. July 31, 2012. <http://www.defenseindustrydaily.com/apkws-ii-hellfire-jr-hydra-rockets-enter-sdd-phase-02193/> (accessed 2012).
- Darrin B. Mirkarimi and Christopher Pericak. Countering the Tactical UAV Threat. January 1, 2003. <http://www.militaryphotos.net/forums/archive/index.php/t-28018.html> (accessed October 1, 2012).
- Defense Acquisition University. n.d. <https://acc.dau.mil/CommunityBrowser.aspx?id=250180> (accessed 2012).



Defense Update. Harpy Air Defense Suppression System. March 4, 2006. <http://defense-update.com/directory/harpy.htm> (accessed October 1, 2012).

Department of Defense. *Risk Management Guide for DoD Acquisition 6th Ed.* (Version 1.0). Washington D.C.: Department of Defense, 2006. Department of Navy. "NAVY Budget 2006 - Exhibit R-3, Project Cost Analysis." Budget, 2006.

Department of the Army Financial Management and Comptroller. "Research, Development, Test and Evaluation." 1998/1999 Budget Estimate. February 1997. <http://www.asafm.army.mil/documents/officedocuments/budget/budgetmaterials/fy98/rforms/vol2.pdf> (accessed 2012 September).

Department of the Army Procurement Programs. "FY 2003 Budget Estimate." 2003. <http://asafm.army.mil/Documents/OfficeDocuments/Budget/BudgetMaterials/fy03/pforms/opa34.pdf> (accessed September 2012).

Department of the Navy Fiscal Year (FY) 2010 Budget Estimates. Other Procurement, Navy Budget Activity 4. May 2009. [http://www.finance.hq.navy.mil/fmb/10pres/OPN\\_BA4\\_BOOK.pdf](http://www.finance.hq.navy.mil/fmb/10pres/OPN_BA4_BOOK.pdf) (accessed September 10, 2012).

Department of the Navy Fiscal Year (FY) 2012 Budget Estimates. Other Procurement, Navy Budget Activity 4. February 2011. [http://www.finance.hq.navy.mil/fmb/12pres/OPN\\_BA4\\_BOOK.pdf](http://www.finance.hq.navy.mil/fmb/12pres/OPN_BA4_BOOK.pdf) (accessed October 8, 2012).

Department of the Navy. "Fiscal Year (FY) 2012 Budget Estimates." Other Procurement, Navy Budget Activity 2. February 2011. [http://www.finance.hq.navy.mil/fmb/12pres/OPN\\_BA2\\_BOOK.pdf](http://www.finance.hq.navy.mil/fmb/12pres/OPN_BA2_BOOK.pdf) (accessed September 2012).

Department of the Navy. Weapons Procurement. February 2011. [http://www.finance.hq.navy.mil/fmb/12pres/omn\\_vol1\\_book.pdf](http://www.finance.hq.navy.mil/fmb/12pres/omn_vol1_book.pdf) (accessed September 2012).

Doehring, Thoralf. "Mk-15 Phalanx Close-In Weapons System." 1999–2011. <http://navysite.de/weapons/phalanx.htm> (accessed October 1, 2012).

Eshel, Tamir. TRAPS - Defense-Update Newscast. September 29, 2010. <http://www.defence-update.net/wordpress/tag/traps> (accessed October 3, 2012).

Federation of American Scientists. "AN/SLQ-32 Electronic Warfare (EW) system." Accessed September, 2012. <http://www.fas.org/man/dod-101/sys/ship/weaps/an-slq-32.htm>.

Federation of American Scientists. "MK-53 Nulka Decoy Launching System (DLS)." Accessed October, 2012. <http://www.fas.org/man/dod-101/sys/ship/weaps/mk-53.htm>

- Global Security, "AN/SPS-67." Accessed September, 2012.  
<http://www.globalsecurity.org/military/systems/ship/systems/an-sps-67.htm>.
- Global Security, "AN/SPY-1 Radar." Accessed September, 2012.  
<http://www.globalsecurity.org/military/systems/ship/systems/an-spy-1.htm>.
- Global Security, "AN/UPX-29(V) Interrogator System." Accessed September, 2012.  
<http://www.globalsecurity.org/military/systems/ship/systems/an-upx-29.htm>.
- Global Security, "MK 15 Phalanx Close-In Weapons System (CIWS)." Accessed October, 2012. <http://www.globalsecurity.org/military/systems/ship/systems/mk-15.htm>.
- Global Security, "MK 34 Gun Weapon System (GWS)." Accessed September, 2012.  
<http://www.globalsecurity.org/military/systems/ship/systems/mk-34.htm>.
- Goolsbee, Mike. "Jet Aircraft Kits." n.d.  
<http://www.scalercmodels.com/jetaircraftkits.html> (accessed October 10, 2012).
- Gryphon Technologies, "Navy Program Guide 2011," 2011,  
[http://www.gryphonlc.com/capabilities/USN\\_Program\\_Guide\\_2011.pdf](http://www.gryphonlc.com/capabilities/USN_Program_Guide_2011.pdf)
- IHS Jane's. "Aegis Weapon System; DANCS; COMBATSS 21." C4ISR & Mission Systems: Maritime 2013, 6 September 2012
- IHS Jane's. "AN/SLQ-32(V) and Surface Electronic Warfare Improvement Program (SEWIP)." Jane's Radar And Electronic Warfare Systems 2011, 12 August 2011
- IHS Jane's. "Arleigh Burke (Flight IIA) class." Jane's Fighting Ships 2013, 25 July 2012
- IHS Jane's. "Mk 15 Close-In Weapon System, Phalanx." Jane's Naval Weapon Systems, 5 March 2012
- IHS Jane's. "Mk 20 Electro-Optical Sensor System (EOSS)." C4ISR & MISSION SYSTEMS: MARITIME 2012, 3 July 2012
- IHS Jane's. "Nulka active missile decoy system." Jane's Radar And Electronic Warfare Systems 2012, 5 March 2012
- IHS Jane's. "Sikorsky SH-60B Seahawk (LAMPS Mk III)." Jane's Fighting Ships, 3 April 2012
- IHS Jane's. October 21, 2005.  
[https://janes.ihs.com.libproxy.nps.edu/CustomPages/Janes/DisplayPage.aspx?ShowProduct-Link=true&DocType=Reference&ItemId=+++1339757&Pubabbrev=JAV\\_](https://janes.ihs.com.libproxy.nps.edu/CustomPages/Janes/DisplayPage.aspx?ShowProduct-Link=true&DocType=Reference&ItemId=+++1339757&Pubabbrev=JAV_) (accessed October 5, 2012).

Jane's Radar And Electronic Warfare Systems. Automated Decoy Launching System (DLS). Nov 8, 2011. <http://articles.janes.com/articles/Janes-Radar-and-Electronic-Warfare-Systems/Automated-Launch-of-EXpendables-ALEX-system-United-States.html> (accessed September 18, 2012).

Jane's Unmanned Aerial Vehicles and Targets . IAI Harpy and Cutlass. December 12, 2011.  
<https://janes.ihs.com.libproxy.nps.edu/CustomPages/Janes/DisplayPage.aspx?DocType=Reference&ItemId=+++1317898&Pubabbrev=JUAV> (accessed October 10, 2012).

Microsoft Support. (2007, January 18). Retrieved September 19, 2012, from Microsoft:  
<http://support.mircrosoft.com/kb/828117>

Military Analysis Network. M157A2 Smoke Generator Set (SGS). February 5, 2000.  
<http://www.fas.org/man/dod-101/sys/land/m1059.htm> (accessed September 2012).

N857, O. (2007). Initial Capabilities Document for Maritime Expeditionary Security. Washington DC: Chief of Naval Operations.

Navy Operation and Maintenance. 2012.  
[http://www.finance.hq.navy.mil/FMB/12pres/OMN\\_Vol1\\_book.pdf](http://www.finance.hq.navy.mil/FMB/12pres/OMN_Vol1_book.pdf) (accessed October 5, 2012)

Navy Research, Development, Test and Evaluation. 2012. Fiscal Year (FY) 2012 Budget Estimates Fiscal Year (FY) 2012 Budget Estimates  
[http://www.finance.hq.navy.mil/fmb/12pres/rdten\\_ba4\\_book.pdf](http://www.finance.hq.navy.mil/fmb/12pres/rdten_ba4_book.pdf) (accessed 9 24, 2012).

Navy Weapons Procurement. 2012.  
[http://www.finance.hq.navy.mil/FMB/12pres/WPN\\_BOOK.PDF](http://www.finance.hq.navy.mil/FMB/12pres/WPN_BOOK.PDF).

Navy, Department of the. finance.hq.navy.mil. February 1, 2011.  
[http://www.finance.hq.navy.mil/FMB/12pres/OMN\\_Vol1\\_book.pdf](http://www.finance.hq.navy.mil/FMB/12pres/OMN_Vol1_book.pdf) (accessed October 4, 2012).

Navy, Department of the. FISCAL YEAR (FY) 2012 BUDGET ESTIMATES. 2011.  
[http://www.finance.hq.navy.mil/FMB/12pres/OMN\\_Vol1\\_book.pdf](http://www.finance.hq.navy.mil/FMB/12pres/OMN_Vol1_book.pdf) (accessed 2012).

Navy, Research, Development, Test and Evaluation . 2012.  
[http://www.finance.hq.navy.mil/FMB/12pres/RDTEN\\_BA4\\_book.pdf](http://www.finance.hq.navy.mil/FMB/12pres/RDTEN_BA4_book.pdf) (accessed September 28, 2012).

Northrop-Grumman. 2009.  
[http://www.as.northropgrumman.com/products/mq8bfirescout\\_navy/assets/fs-fact-sheet.pdf](http://www.as.northropgrumman.com/products/mq8bfirescout_navy/assets/fs-fact-sheet.pdf) (accessed 2012).

- Office, United States Government Accountability. DEFENSE ACQUISITIONS DoD Could Achieve Greater Commonality and Efficiencies among Its Unmanned Aircraft Systems. March 23, 2010. <http://www.gao.gov/assets/130/124311.pdf> (accessed 2012).
- Operation and Maintenance, Navy. 2012. [http://www.finance.hq.navy.mil/FMB/12pres/OMN\\_Vol1\\_book.pdf](http://www.finance.hq.navy.mil/FMB/12pres/OMN_Vol1_book.pdf).
- Procurement of Ammunition, Navy and Marine Corps Budget Activity 1. Department of the Navy Fiscal Year (FY) 2010 Budget Estimates. May 2009. [http://www.finance.hq.navy.mil/fmb/10pres/PANMC\\_BA\\_1\\_Justification\\_Book.pdf](http://www.finance.hq.navy.mil/fmb/10pres/PANMC_BA_1_Justification_Book.pdf) (accessed October 10, 2012).
- Research, Development, Test & Evaluation, Navy Budget Activity 1–3. Department of Defense Fiscal Year (FY) 2012 President’s Budget. February 2011. [http://www.finance.hq.navy.mil/FMB/12pres/RDTEN\\_BA1-3\\_BOOK.pdf](http://www.finance.hq.navy.mil/FMB/12pres/RDTEN_BA1-3_BOOK.pdf) (accessed October 15, 2012).
- Research, Development, Test and Evaluation, Navy. 2012. [http://www.finance.hq.navy.mil/FMB/12pres/RDTEN\\_BA4\\_book.pdf](http://www.finance.hq.navy.mil/FMB/12pres/RDTEN_BA4_book.pdf) (accessed September 24, 2012).
- Rourke, Ronald O’. Navy Shipboard Lasers for Surface, Air, and Missile Defense: Background and Issues for Congress. April 8, 2011. <http://www.fas.org/sgp/crs/weapons/R41526.pdf> (accessed October 1, 2012).
- Security, Global. Army RDT&E Budget Item Justification (R-2 Exhibit). 2003. <http://www.globalsecurity.org/military/library/budget/fy2004/armypeds/0203802A.pdf> (accessed 2012).
- Smart, Jeffery K. “History Of Chemical And Biological Warfare: An American Perspective.” *Medical Aspects Of Chemical And Biological Warfare*. 1997. [http://www.sce-ems.com/ems/NuclearBiologicalChemical/MedicalAspectsOfNBC/chapters/chapter\\_2.htm](http://www.sce-ems.com/ems/NuclearBiologicalChemical/MedicalAspectsOfNBC/chapters/chapter_2.htm) (accessed September 2012).
- Standard Missile-3, Missile Defense from the Sea. (n.d.). Retrieved from [http://www.raytheon.com/newsroom/rtnwcm/groups/rms/documents/content/rtn\\_rms\\_ps\\_sm3\\_datasheet.pdf](http://www.raytheon.com/newsroom/rtnwcm/groups/rms/documents/content/rtn_rms_ps_sm3_datasheet.pdf)
- The Department of the Army, the Navy, the Air Force, and the Marine Corps. 1995. *Treatment of Chemical Agent Casualties and Conventional Military Chemical Injuries*. Washington DC.
- Threston, Joseph T. “The AEGIS Combat System.” *Naval Engineers Journal* 121, no. 3 (October 2009): 109–132.
- Threston, Joseph T. “The AEGIS Weapon System.” *Naval Engineers Journal* 121, no. 3 (October 2009): 85–108.

- Tommy Toy. 2011. <http://tommytoy.typepad.com/tommy-toy-pbt-consultin/2011/05/navys-robotic-helicopter-takes-flight5162011-71028-pm-the-us-navy-is-using-robotic-helicopters-as-part-of-its-surveill.html> (accessed 2012).
- U.S Army. “Three Army Teams Recognized for Reinvention Achievements.” 1999. [http://www.hqda.army.mil/leadingchange/Articles\\_Speeches/HotItems/hotitems1999.htm](http://www.hqda.army.mil/leadingchange/Articles_Speeches/HotItems/hotitems1999.htm).
- U.S. Department of Defense Office of the Assistant Secretary of Defense (Public Affairs). Defense Logistics Agency. March 29, 1996. <http://www.defense.gov/contracts/contract.aspx?contractid=751> (accessed September 2012).
- U.S. Department Of Defense: Office of the Assistant Secretary of Defense (Public Affairs), Defense Logistics Agency. March 29, 1996. <http://www.defense.gov/contracts/contract.aspx?contractid=751> (accessed September 2012).
- U.S. Government Accountability Office. “Environmental Protection: DoD Management Issues Related To Chaff.” David R. Warren. GAO/NSIAD-98-219. 1998. <http://www.gpo.gov/fdsys/pkg/GAOREPORTS-NSIAD-98-219/content-detail.html>.
- Vandroff, Mark. “DDG 51 Program,” Presented to: Surface Navy Association, January 12, 2012. <http://www.navsea.navy.mil/Media/SNA2012/Jan%202012%20CAPT%20Vandroff%20SNA%20Brief%2012%20Jan%20final.pdf>
- Vitech. (n.d.). The Power of CORE. Retrieved 4 19, 2012, from <http://www.vitechcorp.com/products/core.shtml>
- Weapons Procurement, Navy. 2012. [http://www.finance.hq.navy.mil/FMB/12pres/WPN\\_BOOK.PDF](http://www.finance.hq.navy.mil/FMB/12pres/WPN_BOOK.PDF).
- X8R 2.4Ghz 8ch Receiver. n.d. <http://www.hobbyking.com/mobile/viewproduct.asp?idproduct=5540&type=&idparentcat=296> (accessed October 10, 2012).

THIS PAGE INTENTIONALLY LEFT BLANK

## INITIAL DISTRIBUTION LIST

1. Defense Technical Information Center  
Ft. Belvoir, Virginia
2. Dudley Knox Library  
Naval Postgraduate School  
Monterey, California