

OPTIMAL RETROFIT AND PROCESS DESIGN OF DISTILLATION PLANTS FOR ENERGY SAVING AND PROCESS INTENSIFICATION



Massimiliano Errico



DOTTORATO DI RICERCA IN INGEGNERIA INDUSTRIALE
UNIVERSITÀ DEGLI STUDI DI CAGLIARI
XX CICLO

OPTIMAL RETROFIT AND PROCESS DESIGN OF DISTILLATION PLANTS FOR ENERGY SAVING AND PROCESS INTENSIFICATION

MASSIMILIANO ERRICO

Supervisor:
Professor Giuseppe Tola



Dottorato di Ricerca in Ingegneria Industriale
Università degli Studi di Cagliari
XX Ciclo

Acknowledgements

All the people who collaborated to this project are kindly acknowledged. I also thank my marvelous friends at the DICM, Sara, Michela, Daniele, the Finland and Italian Crew, Ely, Mario, my family, all the people in the LUT for their kindness and in particular Benguang Rong who taught me how the research work can be an art. Most of all, I would like to thank Prof. Giuseppe Tola who taught me this job and transmitted me the passion for the research work. No words can explain my gratitude to him who gave me the opportunity to improve myself every day more.

Contents

Abstract	1
Introduction	3
1.1 The Energy Crisis.....	5
1.2 General Law Aspects	5
1.3 A look to the Data	6
1.4 Energy Optimization Tools	7
1.5 The Distillation in the Mesoscale Level.....	8
1.6 References	10
Distillation Fundamentals.....	11
2.1 Introduction	13
2.2 Distillation Processes Classification	16
2.3 Distillation Process Design	17
2.4 Notation.....	19
2.4.1 Superscripts.....	19
2.4.2 Subscripts.....	19
2.5 References	20
Process Retrofit.....	21
Preflash Device Implementation	27
3.1 Crude Distillation Unit with a Preflash Device.....	29
3.2 Description of the Plant.....	31
3.2.1 Simulation of the Plant	32
3.3 The Preflashing Devices Options.....	37
3.3.1 Preflash Drum.....	38
3.3.2 Preflash Column	39
3.4 Final Observations	41
3.5 References	42
Process Intensification of a Light-Ends Plant.....	45
4.1 Introduction	47
4.2 Review in Distillation Trends	48

4.3 Generation of the Retrofit Alternative Configurations from the Existing Plant	50
4.4 Simulation and Results.....	54
4.5 Discussion	58
4.5.1 Energy Savings	58
4.5.2 Heat Exchanger Area Comparison and Selection.....	59
4.5.3 Section Diameter Comparison and Selection	60
4.6 Conclusions.....	62
4.7 Notation.....	63
4.8 References.....	63
Process Design.....	67
Heuristic Rules in Distillation Sequence Design	69
5.1 Introduction	71
5.2 Heuristic Rules During the Time	71
5.3 The Case Study	75
5.3.1 Composition Case 1	77
5.3.2 Composition Case 2.....	77
5.3.3 Composition Case 3	78
5.3.4 Composition Case 4.....	78
5.3.5 Composition Case 5	79
5.4 Rigorous Calculations	79
5.4.1 Case 1.....	80
5.4.2 Case 2.....	80
5.4.3 Case 3.....	81
5.4.4 Case 4.....	82
5.5.5 Case 5.....	82
5.5. Summary	83
5.6 Notation.....	87
5.6.1 Subscripts.....	87
5.7 References.....	88
The Divided Wall Column	89
6.1 Introduction.....	91
6.2 The Divided Wall Column Principles	91
6.3 World Applications of DWCs	95
6.4 Modeling	95
6.4.1 Application of the Fenske-Underwood-Gilliland method	97

6.4.1 Feasible Design Space and Optimization	103
6.5 Short-cut design results	106
6.5.1 Composition Case 1	107
6.5.2 Composition Case 2	108
6.5.3 Composition Case 3	109
6.5.4 Composition Case 4	110
6.5.5 Composition Case 5	112
6.6 Final Considerations.....	112
6.7 Notation.....	113
6.7.1 Subscripts.....	114
6.8 References	114
Synthesis of Distillation Sequences with Less than n-1 Columns.....	117
7.1 Introduction.....	119
7.2 Synthesis Methodology.....	120
7.2.1 General Observations.....	124
7.3 The Case Study	125
7.4 Discussion	127
7.5 Remarks	130
7.6 Notation.....	131
7.7 References	131
Conclusions	135
Appendix A	139
A.1 Distillation Sizing and Cost Evaluation	139
A.2 Heat exchanger cost evaluation.....	140
A.3 Total Annual Cost	140
A.4 Notation.....	140
Appendix B.....	143

Abstract

This work is divided in two principal sections. The first concerns the application of more convenient structures to intensive energy consuming plants built before the energy crisis. Two case studies are considered. The first regards the implementation of a preflash device (drum or column) on a crude distillation unit. The limitations of both apparatuses are considered together with the energy saving realized. Particular emphasis is given to the evaluation of the best structure that matches the scope in the energy plant reduction and the respect of the production specifications. The second case considered regards a light ends distillation plant. Different separation sequences derived from the plant configuration are considered. The possibility to reach a reduction of the energy consumption is considered together with the maximum re-usage of the plant apparatus, that allows to minimize the capital cost investment. The total annual cost is associated to the required heat exchanger area for the condensers and the reboilers and to the column section diameter. The best solution, that satisfy the scope of the retrofit work minimizing at the same time the employing of new equipment and the energy consumption, is then identified.

In the second section of the work the column sequence design is considered. The starting point was the separation of a four components mixture considered with five different feed compositions. All the possible simple column sequences were first analyzed using different sets of heuristic rules and after with more rigorous evaluation. The different solutions are compared to put in evidence the limitations of the heuristic rules, which anyway remain a good tool for a first screening of the most promising structures. The best distillation sequence for each feed composition case is also considered for the implementation of a divided wall column to perform a three component separation. The resulting "hybrid" sequences are made by a simple column that follows or precedes a divided wall column. This type of column was modeled using the modified Underwood-Fenske-Gilliland method to obtain the first design parameters to be utilized as the input to a more rigorous simulation performed with the Aspen Plus simulation package. The different hybrid configurations are then compared with respect to the best simple column structures from which are derived.

In the last part of the work a new method to map the space of distillation columns with less than $n-1$ columns is proposed. Up to now this configuration space was never predicted in a systematic way and only heuristic rules are available to predict

only a few of all the possible configurations. Including more distillation column configurations in the research space increases the possibility to identify the sequence that satisfies the research scope. The generation method is presented for a four components mixture but is absolutely general and can be applied for any number of components.

Chapter 1

Introduction

In this Chapter the motivation of the thesis and the problem of the energy optimization are presented, giving a look to the general procedures presented during the years and to the evolving of the problem for an optimal usage of the energy from the energy crisis time up today. The process optimization technique was focused on separations by distillation that is the most energy demanding industrial separation process. Some advantages of this separation method are presented together with trend data on energy consumption and on the repartition between different energy sources to justify the high interest of this research field.

1.1 The Energy Crisis

When in 1973 the Arabic countries stopped exporting oil to the USA and other Western nations, the importance to optimize the employing of energy changed all the different habits of a population that had never worried about energy before that time. The energy crisis forced the world to consider many things about the cost and the supply of energy that were never taken into account before, not only from a political point of view but also considering for the first time a more responsible energy usage.

Obviously the effects of the energy crisis, or in this case is better to say of the oil crisis, were disastrous. In the USA the price of gasoline quadrupled in a few months, rising from 30 cents to \$ 1.20. The total oil consumption dropped by 20%. Many measures were approved to reduce the energy consumption. The speed limit on highways was reduced to 55mph, thermostats in homes and offices were dramatically lowered and tax credits were offered to people who developed and used alternative sources of energy like the wind and the sun. From this brief view of an extreme situation it is possible to say that today's fuel economy depends on the efforts to preserve oil in the 70's.

Even if we start talking about alternative energy sources, in industrialized societies oil is the lifeblood of the nations economy and for the next 25 years oil will still be the world's dominant source of energy.¹ The oil embargo should be considered as a wake up call to all the industrialized world to understand well the importance of making a reasonable exploit of energy and to promote different solutions able to lowering the energy demands of our industrial system.

1.2 General Law Aspects

Starting from the oil crisis time the necessity of a common regulation about energy employment and pollution control became essential. For this reason 26 member countries founded the International Energy Agency (IEA). The aim of this agency is to assure a reliable, affordable and clean energy for the citizens of the member states. The role of the IEA obviously changed during the years; in the years of the oil embargo the role was about the coordination in the oil supply emergencies, now the work is more focused on climate changes policies, market reform, energy technology collaboration and the outreach of a common view to other countries especially the major producers and consumers of energy like China, India, Russia and OPEC countries. The IAE conducts a broad programme of energy research, data compilation and publication of good practices in order to sensitize the public opinion

about energy policy and environmental protection. To assure a common effort in the environmental protection, in 1996 the European Community with the Directive IPPC (Integrated Pollution Prevention and Control) stated the procedure to obtain the authorization to operate for an industrial plant. For the first time a common law put in evidence the strict interaction between human activities and the environmental impact. Aspects as the emission in air, water and soil, the raw material usage and the energy efficiency were taken into account inside the directive regulations.

1.3 A look to the Data

The energy saving and the environmental protection is the same subject looked from a different point of view. Saving energy means also to avoid emissions from the energy production system and thus it is equal to say that is a way to defend the environment.

The availability of an adequate energy source is necessary for most of the economic activities and makes possible the high standard of living requested by the developed society. The global energy request risen since the industrial revolution and this trend never stops. From 1960 to 1990 the world energy request rose from 3.3 to 5.5 gtoe (gigatonnes oil equivalent) and the fossil fuels contribute to about 85% of the world's energy consumption. The global energy consumption is expected to grow by 75% in 2020 compared to 1995 due to the growing of the Southeast and East Asia economies.²

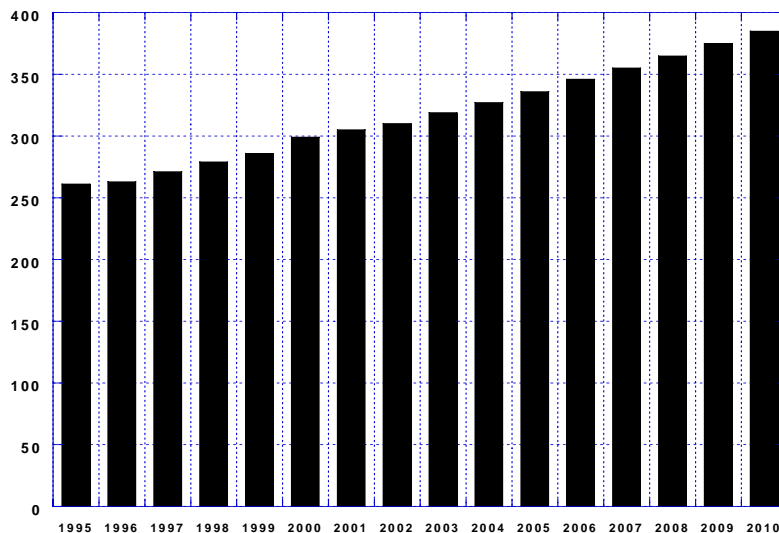

Figure 1.1: Electric energy demand prevision in Italy (TWh).

This huge energy request requires a full understanding in competing energy and environmental aspect to avoid the possibility to reach a breakpoint. As everywhere in Europe also in Italy, the energy request is continuously rising. The histogram of Figure 1.1 shows the increasing demand of the electric energy from the 1995 with a prevision up to 2010.³

Table 1.1 offers an estimation up to 2010 of the repartition between different primary energy sources.³ It is possible to see that oil and natural gas are still the most important energy sources also for the Italian energy market.

	1996	2001	2002	2003	2005	2010
Solid Fuels	11.3	13.7	13.7	13.7	13.9	14.0
Natural Gas	46.4	58.6	58.2	62.1	67.5	75.0
Electric Energy Importation	8.2	9.9	10.4	10.5	10.5	12.0
Oil	94.4	89.4	89.0	85.6	84.3	78.0
Low Cost Fuels	0.0	1.5	1.7	1.7	1.8	3.0
Renewable Sources	11.4	13.0	12.4	13.3	14.0	16.0
Total	171.7	186.2	185.4	186.9	192.0	198.0

Table 1.1: Italian energy demand from primary sources up to 2010.

1.4 Energy Optimization Tools

In the late 90's the concept of progress integration was introduced.⁴ This methodology, applied for mass or/and energy integration, is a tool to systematize pollution-prevention decisions. Process integration is a holistic approach to process design, retrofitting and operation which emphasizes the unity of the process. For this reason with the process intensification concept it is possible to understand well the aim of the production considering the process in a global way. The process intensification methodology includes three main steps; synthesis, analysis and optimization.

In the synthesis the designer screens various process technologies, different configurations and operating conditions. This is an important step and the availability of techniques to identify all the possible configurations for a request separation task can assure the inclusion of the best solution. The second step is the analysis of the generated solutions. Mathematical models, empirical correlations or computer-aided process can be used. This analysis can be a huge work and sometimes heuristic rules can be used to reduce the searching space. The

optimization process consists in the examination of the performance of the considered configurations in order to verify if the design object has been meet.

In the 70's the Pinch Technology emerges as one of the most popular tools for heat exchanger net work design to reduce the energy request of the whole system.⁵ This powerful tool is still used and many plants adopt this technique in revamping works addressed to the reduction of energy consumptions. During the years the definition of Pinch Technology changes to Pinch Analysis to empathize the generality of the method that is not limited to the design of heat exchanger networks, but is also devoted to the best design of the whole process.⁶

1.5 The Distillation in the Mesoscale Level

Traditionally the engineering science has been divided into principal areas like civil, electrical, mechanical, chemical and so on. Anyway during the time all these different figures, also maintaining their specific competences, start to converge in some common areas. The most discussed is for sure the environmental saving and alternative design tool to include high profits and pollution reduction at the same time. This area is usually called sustainable design.

To study the impact of process design on the environment and to identify in which step or level of the process it is necessary to operate to reach the goal of the better employment of the resources. It is possible to identify three levels or scales according to Figure 1.2.⁷

The macroscale level regards the material flows in the industrial economy from natural resource extraction to the consumer product disposal, in the second level, named mesoscale, the chemical manufacturing process is considered. The third level is called microscale, the reaction pathway analysis and the material design method are examined. In this thesis work only the second level is considered and analyzed for a reduction in the energy consumption of the process.

Among the unit operations and inside the chemical processes, distillation is by far the most used separation technique.

Different reasons are the basis of this wide diffusion:

- the capital cost of the operation depends by the capacity of the plant through the well known 0.6 rule. Other separation methods, like membranes, have an exponential near to the unity.
- It is not necessary an external mass separation agent.
- Along the years a lot of knowledge about the process, the scale-up, the control system, the dynamic behaviour, has been achieved.

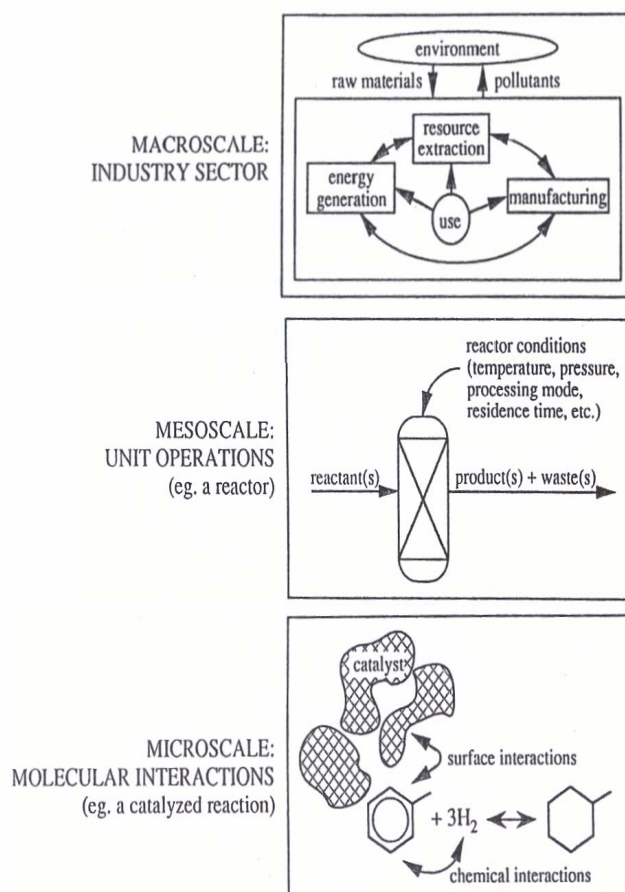

Figure 1.2: Macro-, meso, and microscales in the pollution prevention strategy.

On the other hand some limitations were observed, like the inapplicability of the method to heat-sensitive compounds and, most of all, the high energy consumption of the operation. This aspect points out the necessity of reviewing the way to perform the separation with a less energy consumption.

In this work the problem of the reduction of the energy load of a separation plant is analyzed from two different points of view. The first is to examine the possibility to modify an existing plant to reach the goal of a better energy exploitation. Many plants were constructed before the energy crisis so the attention on energy recovery was limited. These plants represent a good opportunity to improve the industrial earnings (achieving simultaneously a pollution prevention) with a minimal change of the existing plant. The latter point of view regards design methodologies to include as much as possible flowsheet alternatives for a separation task. This topic is of increasing interest because, with the employing of more powerful tools of analysis, it is possible to analyze an evergrowing number of possibilities in a brief

time. Of course by increasing the searching space the possibility to obtain the best solution to satisfy the scope of the work becomes higher.

To have a look to the entity of the problem in the USA it was estimated that 40000⁸ distillation columns use approximately 24% of the energy consumed by the manufacturing sector,⁹ or in other terms the 7% of the total energy demand of the USA.¹⁰

The actual system of production is no more sustainable from an environmental point of view. Nevertheless in the last 10 years in Europe many progress were made in the pollution prevention. Considering that a big part of the European pollution is from the industries, the problem to reduce the energy load of separation system plants represents an interesting way to agree industrial interest and social ethic at the same time.

1.6 References

- (1) G8, Growth and Responsibility in the World Economy, *Summit Declaration*, Heiligendamm, **2007**.
- (2) Allen, D. T.; Shonnard, D. R. Green Engineering Environmental Conscious Design of Chemical Processes. NJ, Prentice-Hall, Inc., **2002**.
- (3) AIEE (Italian Association of Energy Economists)
- (4) El-Halwagy, M. M. Pollution Prevention through Process Integration Systematic Design Tools. USA, Academic Press. **1997**.
- (5) Errico, M.; Maccioni, S.; Tola, G.; Zuddas, P. A Deterministic Algorithm for the Synthesis of Maximum Energy Recovery Heat Exchanger Network. *Comp. Chem. Eng.* **2007**, 31, 773.
- (6) Linnhoff B. et al., User Guide on Process Integration for the Efficient Use of Energy. UK, Institution of Chemical Engineers, Warwick Printing Company, **1997**.
- (7) Allen, D.T.; Kirsten Sinclair Rosselot, Pollution Prevention for Chemical Process. NY, Wiley Interscience, **1997**.
- (8) Humphrey, J. L.; Seibert, A. F. New Horizons in Distillation. *Chem. Eng.* **1992**, 99(12), 86.
- (9) Lucia, A. The Long and the Short of Energy Consumption in Distillation. *AIChE Annual Meeting*, **2007**, Salt Lake City, Utah.
- (10) Gmehling, J.; Menke, J.; Krafczyk, K.; Fischer, K. Azeotropic Data, Part I and Part II, VCH Publishers, Weinheim, New York, **1994**.

Chapter 2

Distillation Fundamentals

In this Chapter the basic fundamentals of distillation processes are summarized and some indications on solving methodologies are given. A complete review of the design methodologies and of the most used numerical technique is out of the scope of the work but useful information to this regard can be found in the cited literature.

2.1 Introduction

Distillation processes were known from the 2nd millennium BC by Babylonian alchemists, but the first exact description of distillation apparatus was given in the fourth century by Zosimus of Alexandria.¹ In the following centuries the knowledge of the distillation increases and around the eleventh century this technology was used for the first time in the northern Italy to produce alcoholic beverages. The typical application at that time was the production of spirits.²

Obviously, today many things are changed in the technology used to perform the separation and distillation process becomes the most used separation technique. Passing from pot stills to the modern distillation columns, the fundamentals of the separation method remain the same: the different chemical substances contained in a mixture are separated according to the difference on their vapour pressure.

The vapour pressure is defined as the equilibrium pressure between the molecules leaving and entering the liquid surface at a fixed temperature. This value is related to the substance boiling point and to a high vapour pressure corresponds to a low boiling point. It is obvious that the vapour pressure and the boiling point depend on the amount of components in the mixture. The boiling point diagram or T-xy diagram reported in Figure 2.1, shows, at a fixed pressure, the different equilibrium composition for a binary mixture. In this case a benzene-toluene system is considered. From the diagram it is possible to read directly the pure component boiling points; the boiling point of benzene is that at which the mole fraction of this compound is 1, the boiling point of toluene can be read at a zero benzene mole fraction. The bubble and the dew curves are indicated. The first includes all the temperatures at which the liquid phase starts to boil; the latter includes the temperature points at which the saturate vapour starts to condense for the considered composition range. The region above the dew point curve is called superheated vapour region, and the region below the bubble point curve is the subcooled liquid region. Considering a subcooled liquid mixture (point A) when it is heated its temperature rises, without changing the composition, until it reaches the bubble point (point B) and starts to boil. The equilibrium composition of the vapour with the boiling liquid corresponds to point C. This diagram can be used to predict the composition of a single equilibrium stage, given a feed composition and the stage temperature.

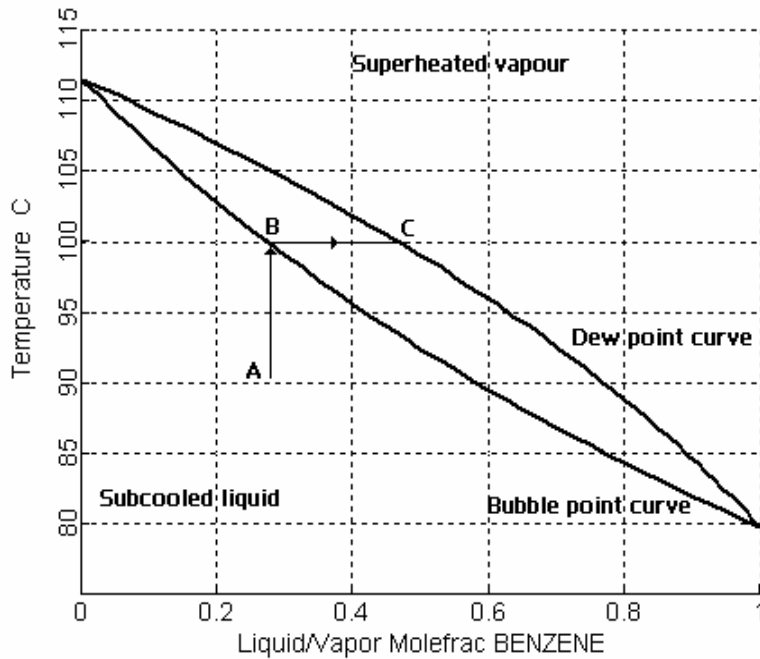

Figure 2.1: T-xy diagram for the Benzene-Toluene system at 1 atm.

The difference between the vapour and liquid composition is the driving force (D_{ij}) and is the base parameter of distillation processes. This value is inversely proportional to the energy consumption and directly proportional to separability.

$$D_{ij} = y_i - x_i \quad (2.1)$$

The driving force value is the basis of a class of design methods called “*driving force based design*” for the optimal selection, with respect to the cost of the operation, of the design parameters like the feed location and the corresponding reflux ratio.³

Another way to express the driving force for the distillation process is by referring to the relative volatility; this parameter is very common in the distillation design methods and its value is proportional to the ease of the separation. The relative volatility of component i with respect to component n is defined as:

$$\alpha_{in} = \frac{\left(\frac{y_i}{x_i}\right)}{\left(\frac{y_n}{x_n}\right)} = \frac{K_i}{K_n} \quad (2.2)$$

If this value is close to 1 it means that the components have a very close vapour pressure, thus they have similar boiling points and their separation by distillation will be difficult. The relative volatility value can be used to predict the vapour-liquid equilibrium for an ideal mixture. With simple analytical substitutions it is possible to obtain the following equation that it is useful to construct the x-y diagram (at a fixed pressure) that is the base for graphical design methods, like the McCabe-Thiele one, that allows to evaluate the number of theoretical stages necessary for the separation and consequently the height of the column.

$$y_i = \frac{x_i \alpha_{in}}{1 + x_i (\alpha_{in} - 1)} \quad (2.3)$$

Equation 2.3 can be combined with Equation 2.1 to obtain the following general equilibrium condition.

$$D_{ij} = \frac{x_i \beta_{in}}{(1 + x_i (\beta_{in} - 1))} \quad (2.4)$$

$$\beta_{in} = f(T, P, x, y, \phi) \quad (2.5)$$

The concept of equilibrium or theoretical stage is of fundamental importance in distillation design. A theoretical stage is defined as a contacting stage in which equilibrium is attained between the two phases involved.³ Thermodynamic correlations can be used to determinate the temperature and the concentrations of the equilibrium streams at a given pressure. Utilizing a single equilibrium stage it is possible to achieve a limited degree of separation, because a net transfer between two phases can occurs only when there is a driving force, that, in this case, is a difference in concentration values. When the equilibrium is reached the driving force and consequently the net mass transfer is equal to zero. Anyway it is possible to repeat the process by taking the vapour from the separation stage and by feeding it to another separation stage where a partial condensation takes place. The liquid obtained can be fed to another separation stage to be partially vaporized. By repeating the procedure, a cascade of equilibrium stages is obtained with the vapour phase continuously enriched in the most volatile component and the liquid phase with the less volatile component becoming more concentrated. In principle, by creating a large enough cascade an almost complete separation can be carried out. A typical cascade stage separation process is showed in Figure 2.2:

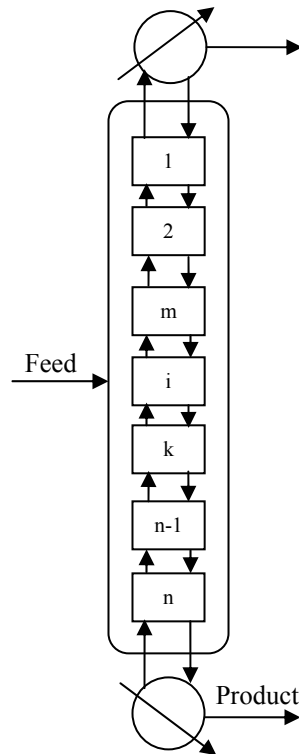

Figure 2.2: Cascade of equilibrium stages with a condensing and a reboiling system.

The liquid needed in the first stage (*reflux*) is given by condensing, in a total or partial overhead condenser, the vapour that leaves the first stage. The remaining part of the overhead stream is withdrawn as distillate. The distillate flow stream is in liquid or vapour phase depending on the use of a total or partial condenser, respectively. The vapour feed needed at the bottom of the cascade is obtained vaporizing in a reboiler part of the liquid leaving the last stage. The remaining part of the liquid is withdrawn as a bottom product. The number of theoretical stages is converted to actual stages by means of the tray efficiency that takes into account the real behaviour of the stage.

The design methods available for distillation apparatus are well known and in many texts can be found the different design methodologies and their application range.⁵⁻⁷

2.2 Distillation Processes Classification

There are a lot of classifications about the distillation process in function of which aspect is taken into account. One of the most common classifications is according to the nature of the feed processed. We refer to *binary distillation* if there are only two

components to be separated, this is the simplest case and a lot of theoretical works refer to the binary case. In the *multicomponent distillation* process the feed mixture contains more than two components; a classical example is the oil processing that contains thousand of components. The behaviour of the feed components determines successive distinction. It is common to distinguish between *ordinary distillation* and *azeotropic distillation*. The first refers to components with a regular thermodynamic behaviour, the latter regards components for which the liquid and the vapour phases can reach the same composition at a fixed point in the distillation process. No further separation can occur after this point without changing the operative variables of the process.

Another classification is about the way by which the feed and the products are introduced and withdrawn in the process. In *continuous distillation* processes the feed/s and the products are going into and out at the same time. Instead in *batch distillation* the feed and the withdrawn are not supposed at the same time. Both distillation processes are industrially used for different purposes. Usually continuous processes are more convenient for large feed flow rates, batch processes are preferred for low productions or for plants that, with the same apparatus, must produce different substances. Another technical classification can be made about the type of column internals. The separation principle of distillation processes is the mass transfer across the vapour-liquid interface, for this reason any distillation equipment has to provide a high mass transfer rate. *Tray columns* and *packed columns* are most often used for distillation. Proper choice of column internals is very important for the effective and economical separation, anyway is not always possible to define an unambiguous choice because both tray and packed columns can be modified to fulfil different requirements. Useful guidelines on this topic are reported in the literature.⁸

2.3 Distillation Process Design

Different levels of process description can be used depending on the scope of the design calculations. Traditionally there is a distinction between rigorous and short-cut design methods. Both of them are used in this thesis work. In particular in this first part of the work, where it is necessary a close representation of the real plants and most of the design parameters are known, the first approach is preferred. The short-cut methods that are used in the second part of this thesis, and explained in detail in a specific section, are usually applied to obtain first design parameters or a fast screening between different design alternatives. All the calculations performed in the thesis were made with the process simulation software Aspen Plus. For rigorous calculations the RADFRAC and the PETROFRAC models that are based

on tray by tray calculation, were chosen. Considering the more general stage representation reported in Figure 2.3, valid in the general case of multiple feeds, vapour and liquid withdrawals and heat transfer in the stage, it is possible to apply the following equations.

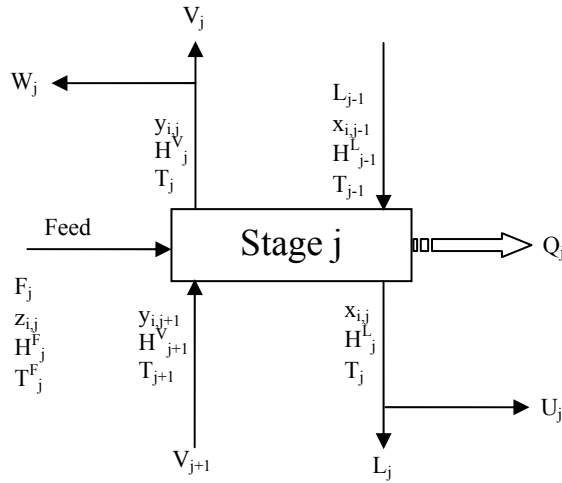

Figure 2.3: General equilibrium stage for distillation processes.

Material balance (one for each component and each stage):

$$L_{j-1}x_{i,j-1} + V_{j+1}y_{i,j+1} + F_j z_{i,j} - (L_j + U_j)x_{i,j} - (V_j + W_j)y_{i,j} = 0 \quad (2.6)$$

Equilibrium relation (one for each component and each stage):

$$y_{i,j} - K_{i,j}x_{i,j} = 0 \quad (2.7)$$

Summation equations (one for each stage):

$$\sum_{i=1}^{N_c} y_{i,j} - 1.0 = 0$$

$$\sum_{i=1}^{N_c} x_{i,j} - 1.0 = 0 \quad (2.8)$$

Energy balance (one for each stage):

$$L_{j-1}H_{j-1}^L + V_{j+1}H_{j+1}^V + F_jH_j^F - (L_j + U_j)H_j^L - (V_j + W_j)H_j^V - Q_j = 0 \quad (2.9)$$

To solve these equations vapour-liquid equilibrium (VLE) data are required, and all the equations must be solved simultaneously. Details about solving methods can be

found in the Aspen Manual Guide⁹ or in specific books voted on numerical methods.^{8,10}

2.4 Notation

L = liquid molar flow rate
V = vapour molar flow rate
H = stream enthalpy
T = temperature
P = pressure
F = feed molar flow rate
z = feed molar fraction
y = vapour molar fraction
x = liquid molar fraction
U = liquid side stream
W = vapour side stream
Q = exchanged heat
K = equilibrium K-values
D = driving force
 α = relative volatility

2.4.1 Superscripts

L = liquid phase
V = vapour phase

2.4.2 Subscripts

i = component index
j = stage index

2.5 References

- (1) Forbes, R. J. Short History of the Art of Distillation. E. J. Brill, Leiden, **1948**.
- (2) Libavius, A. Die Alchemie des Andreas Libavius, ein Lehrbuch der Chemie aus dem Jahre 1597. Verlag Chemie, Weinheim, **1964**.
- (3) Bek-Pedersen, E.; Gani, R. Design and Synthesis of Distillation Systems Using a Driving Force Based Approach, *Chem. Eng. & Proc.* **2004**, 43(3), 251.
- (4) Peter, M. S.; Timmerhaus, K. D.; West, R. E. Plant Design and Economic for Chemical Engineers, McGraw-Hill, NY, **2003**.
- (5) Perry, R. H.; Green, Don W. Perry's Chemical Engineers' Handbook, 7th edition, McGraw-Hill, NY, **1998**.
- (6) Seider, D. S.; Seader, J. D.; Lewin, D. R. Process Design Principles Synthesis, Analysis, and Evaluation, John Wiley and Sons, Inc. USA, **1999**.
- (7) Sinnott, R. K. Coulson & Richardson's Chemical Engineering, Vol.6, 3rd edition, Butterworth Heinemann, **1999**.
- (8) Stichlmair, J. G.; Fair, J. R. Distillation Principles and Practice. Wiley-VCH, New York, **1998**.
- (9) Aspen Manual Guide version 13.0.
- (10) Constantinides, A.; Moustofi, N. Numerical Methods for Chemical Engineers with Matlab Applications. Prentice Hall PTR, **1999**.

Part I
Process Retrofit

Introduction

Industrial plants built before the oil crisis of 1973 were generally designed following the principle of a low capital cost investment to obtain the maximum rate of return. Energy saving tools were taken into account only in the case of an obviously increasing of the return of the investment and no engineering efforts were focused on energy saving. Now with high energy costs, narrow profit margins and the necessity to reduce the pollution emission, the energy efficiency of a process dictates the competitiveness of a plant. The energy consumption balance of the plant becomes one of the major steps in the design process of new installations, but what about all the old plants that are still running?

The bigger part of the industrial Italian plants was built before the energy crisis, especially the petrochemical and chemical plants. Obviously there is a big economic incentive to look these old designed plants and to retrofit them with more energy efficient apparatuses or applying more energy efficient process techniques. The evaluation and the redesign of an existing plant to increase the production performance is usually called *process retrofit* and it is possible to say that is one of the major process engineering occupations. About 70% of the projects in process industry were retrofit projects.¹ Retrofit of an existing plant is a difficult task, more complex than the new process design;² many parameters must be considered and sometimes it is not possible to quantify all of them. Anyway general rules can be derived from the literature that reports both successful and disastrous real cases.

First of all it is necessary to define the objective of the retrofit work and to identify the bottlenecks of the process. Typical objectives are to increase the throughput capacity, to reduce the energy load, to utilize most efficiently the raw materials, to reduce the environmental impact and the waste generation. The identification of the process bottlenecks is a crucial step that can affect the final results of the retrofit work. Rong et al.³ recognize six of the most common bottlenecks in an industrial plant:

- *Bottlenecks of Scale*: are mainly derived from physical limits of the apparatus and they are of crucial importance in the case of increasing of the production capacity. Typical scale bottlenecks are the column diameters, heat exchanger area, retention time and stirring velocity, operating temperature and pressure, etc.
- *Bottlenecks of Energy Consumption*: are related to the hot and cold utility consumption, interconnection of heat exchanger, etc. These types of bottlenecks make the process less energy efficient.

- *Bottlenecks of Raw Material Consumption*: excessive raw material consumption usually is related to the reaction and separation section of the plant.
- *Bottlenecks of Environmental Impact*: these types of bottlenecks contribute to the generation of different pollutants and are usually concerned with the reaction and separation sections.
- *Bottlenecks of Safety*: these bottlenecks are related to the process flexibility, operability and controllability.
- *Bottlenecks of Feedstocks*: are related to the change of feedstocks due to change in the market conditions. It is a common situation when, for example, it is necessary to substitute the catalyst of reactors.

There are different techniques to identify the process bottlenecks and the computer simulation is one of the most important methods. Once the bottleneck is identified it can be removed utilizing a process simulator combined with the equipment design. During the retrofit process it is important to follow some general principles; one of the most meaningful is the maximum usage of the existing equipment and its reassignment. In fact opportunities arise from the underutilized capabilities of the existing equipment. If the designer is able to correctly identify the opportunities and the limits of the existing equipment it is possible to obtain a lower revamp investment. Another point to outline for the success of the retrofit work is the necessity of collaboration at different levels of the plant administration. It is fundamental the confrontation with the knowledge derived from the industrial experience that can represent a good starting point for the retrofit analysis. Apart from these general considerations every retrofit work is different to another one. Each plant is different, with different process units and different limits and opportunities, for this reason the retrofit work could be more complicated than a new design and the interaction between new and old must be evaluated in a very careful way. Two retrofit studies are presented in the following chapters. Both are from a distillation unit in a petrochemical plant and are finalized to the energy demand reduction. The great attention of the refining work on the separation units used, derived from the huge energy consumption, quantified in several MJ/s,⁴ that put these plants as the most important areas for energy integration to generate improved designs.

References

- (1) Gundersen T. Retrofit Process Design – Research and Applications of Systematic Methods, In *Foundation of Computer Aided Process Design*, CACHE Elsevier, **1990**.
- (2) Sloley A. W.; Fraser A. C. S. Consider Modeling Tools to Revamp Existing Process Unit. *Hydrocarbon Processing*, **2000**, June.
- (3) Rong B.G.; Yu H. F.; Kraslawski A.; Nystrom L., Study on the Methodology for Retrofitting Processes, *Chem.Eng. Technol.* **2000**, 23(6).
- (4) Sharma R.; Jindal A.; Mandawala D.; Jana S. K., Design/Retrofit Targets of Pump-Around Refluxes for Better Energy Integration of a Crude Distillation Column, *Ind. Chem. Eng. Res.* **1999**, 38.

Chapter 3

Preflash Device Implementation

Refiners are active in improving the energy efficiency of the factory. Usually it is always possible to improve the energy efficiency of the plant, but investments are usually required. Anyway oil refineries have a record in investments in energy-saving projects. The energy-saving projects are amongst the main approaches to achieve a reduction in the emission of green house gases at a reasonable cost. The plant layout, especially in retrofit situation, is a key influencing factor for the improvement projects.

3.1 Crude Distillation Unit with a Preflash Device

It was evaluated that the energy requirement for crude distillation unit plants is an amount of fuel equivalent to the 2% of the total crude processed.¹ For this reason there is a continuous interest to identify ways to improve the energy efficiency of the existing plants.

Different type of solutions were proposed during the years; in the first half of 80's the most popular strategy to increase energy recovery between process fluids was the Pinch method,² after that other solutions were considered including also the modification of the distillation design. One popular revamping solution is the employing of preflash device, a drum or a column, to save energy in crude distillation plants following the first indication given by Brugma.³

The basic idea of a preflash device implementation is to remove the light components of the crude before entering in the furnace. The vapour stream obtained can then be introduced at the furnace outlet or in an appropriate location of the main column. In this way it is possible to reduce the heat duty of the distillation unit and the furnace and to have also an improvement of the hydraulic performance of the heat exchanger network.^{4,5}

It is a common opinion⁶ that the best preflash location is downstream the desalting process in order to remove, with the light components, also the water carryover that can cause corrosion in the following devices or vaporization in the control valves.

Two main approaches for the preflash implementation have been considered in the literature; the first concerns the impact of the preflash device on the heat exchanger network and the second is about the impact of this device on the main column performance. In the former category Harbert,⁴ Feintuch et al.⁵ and Yahyaabadi^{6,7} made a very clear review of the problem and give useful information to complete the general knowledge about the behaviour of the system. Feintuch et al. consider the modification of the preheating crude network to increase the energy recovery; they focus their attention on the maximum utilization of the existing equipment. In particular they consider the hydraulic limitations and the pressure drop of the modified system and observe that the implementation of a preflash drum just downstream the desalter is able to decrease the operative pressure of the heat exchangers between the flash drum and the furnace. Thus no new equipments are necessary to increase the energy savings in the whole heat exchanger network. They also report that this solution is cost effective with a payout period of less than 3 years. Yahyaabadi studies common problems in preheating trains and the best placement of the preflash drum in the preheat train network below the desalter.^{6,7} He finds that the location of the preflash device has only a small effect on the hot and

cold utility consumptions but it is of great importance on the pressure drop and on the average skin temperature of the furnace. There are also some cases in which it is possible to remove part of the heat exchanger network obtaining additional savings on the operating costs. Recently it was also considered the possibility to employ a preflash system for heavy oils,⁸ that up to now was not taken into account due to the small amount of vaporization that can be achieved. However also in this case it is possible to eliminate water carried over from the desalter and some light components, thus reducing the pressure at the furnace inlet.

The second approach considered in the study is the behaviour of the main column when the preflash device is introduced. In this case there are many criticisms about the possibility to achieve a real energy saving. We refer in particular to the meaningful works of Ji and Bagajewiz⁹ and of Golden.¹⁰ The former work includes the preflash drum or the preflash column in a design method for the whole system including the main column. They make a detailed analysis explaining the effect of the light compounds of the crude, called *carrier-effect*, in improving the separation of the gasoil fraction and also compared different carrier gases to improve the gasoil yield. In another work,¹¹ the same authors consider the preflash and the main column system integrated with the vacuum column, and find that the whole system has an energy request slightly smaller than the base design without the preflash system.

The position of Golden¹⁰ on the performance of the preflash device is more critical. He analyzes many parameters that influence the performance of the main column, like the flash drum temperature, the flashed vapour feed location, the effect of flashed crude entrainment in the vapour stream and the quench effect of the flashed vapour in the main column for a fixed outlet furnace temperature. He made a complete study of the preflash drum theory and reports a revamp case. This case study fails due to a feed lighter than the design case highlighting the necessity to design the preflash system for the light oil processed. Anyway this result can not be considered meaningful of a poor preflash performance. In fact every device has a maximum efficiency in the design operative range, so it is usual that poor performance happens in unexpected situations.

The study presented in this thesis starts by considering a real plant crude unit with a high energy consumption due to the high furnace duty, and the possibility of energy savings utilizing a preflash device is evaluated. This problem differs from the previous works already published, because utilizes real data plant and describes how it is possible to obtain a compromise between production and energy savings without changing the main column lay out.

3.2 Description of the Plant

The Crude Distillation Unit (CDU) is the first separation process that takes place in a refinery plant.

Figure 3.1 shows a simplified view of the plant. A 42°API crude, stored at a temperature of about 50°C, is heated in the first section of the heat exchanger network that utilizes as heating stream the lightest stream from the main column; in this way the crude oil reaches a temperature of about 120°C and is fed to the desalter to remove inorganic salts, impurities and soluble metals. Then the desalted crude flows through the second section of the heat exchanger network. Due to the great attention on energy integration, by maximising heat exchanges between the crude oil and the product streams from the main column, the crude can reach a maximum temperature of about 240°C. This temperature is still too low to achieve the grade of crude vaporization necessary for the separation in the main column and thus a furnace is always necessary. The temperature of the exiting stream from the furnace is about 345°C and fuel oil or fuel gas, depending on the refinery availability, is used as energy source. All the heat needed for the separation is given in the furnace, so no reboiler occurs in the main column.

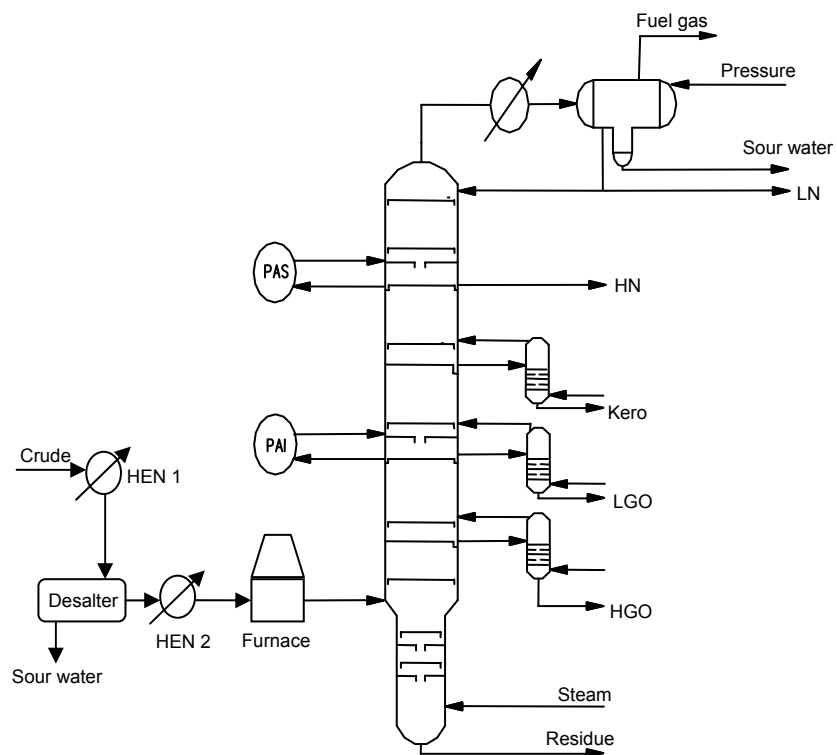

Figure 3.1: Crude Distillation Unit configuration.

The high temperature difference between the inlet and the outlet streams of the furnace and the high flow rate of the crude processed make the furnace as one of the highest energy consumer of the whole refinery. It follows that also the cost of this unit is a meaningful part of the overall production costs.

From the exit of the furnace the heated crude is fed to the main column that is a conventional crude distillation column able to process about 940 m³/h with the main characteristics summarized as follows:

- a stripping section below the feed location with few plates and a steam stream introduced in the bottom to strip the light components dragged in the liquid;
- four product side withdrawals; that from the top to the bottom, are: heavy naphtha (HN), kerosene (Kero), light gasoil (LGO), heavy gasoil (HGO). The Kero, LGO, HGO streams are steam stripped in side columns and the vapours are fed again to the main column a few plates above the withdrawn. The stripped liquid goes in the heat exchanger network for the feed preheating. Each side stripping column has four plates with steam and liquid moving countercurrent;
- two pomparounds corresponding to the HN and the LGO sidestreams to regulate the vapour and liquid loadings;
- a partial condenser from where a light naphtha (LN) stream is obtained as liquid distillate and partially refluxed to the column. In this unit a stream of incondensable and fuel gas is also obtained, and part of this stream is recycled into the condenser to obtain a proper value of the pressure. The water added in the column with the bottom steam and with the side strippers is removed in the condenser's pot and is sent to the waste water plant unit.

The CDU has a strategic role in the overall production asset. In fact the product streams for the main column are the feed for other units of the plant, so the global performance of the refinery production is strictly related to the first separation that here takes place.

3.2.1 Simulation of the Plant

To make a comparison between different retrofit solutions for an existing plant it is necessary to start from a simulation that is as much as possible close to the real plant behaviour. To develop a good simulation is a difficult task and many plant data and much time are needed together with a good technical knowledge of the plant. It is possible to describe the simulation procedure through these three principal steps:

- definition of the flowsheet
- definition of the operative variables
- choice of the thermodynamic model

For the former point it is necessary to choose the streams that must be included in the model. The choice to include in the model all the process streams as represented in Figure 3.1 makes the simulation work more complicated because in a real plant it is usual to measure only a few selected variables of the streams of particular interest for the production scope. Thus it is impossible that all the streams are perfectly characterized. To overcome this problem it is necessary to refer to indications of the plant operators and of course to make a series of simulation tests to well understand the behaviour of the undefined streams on the model performance.

Regarding the second point the analysis of the reconciliated plant data was made first. Temperatures, pressures and flow rates were collected every 12 minutes for a month and the period of time in which these parameters were constant was selected to obtain a mean value of the observed parameter to utilize in the simulation.

An other important input data required for the simulation model is the crude oil characterization. It is know that the oil is a mixture of so many components that is not possible to make a detailed classification based in terms of chemical compounds. For this reason the crude is usually specified by means of distillation curves obtained by distilling a crude sample. Here the True Boiling Point (TBP) curve is used. The accuracy of the property prediction strongly depends on the accuracy of the TBP curve used.¹²⁻¹⁴ In many refineries it is often available only the crude assay, but to obtain a good simulation a more detailed TBP curve is necessary and moreover also the crude assay could not represent the crude processed in the time of the observation. The difference in the real TBP and the assay data available in the refinery data base can be due to the blending of different crude, stratification or contamination of the crude with another one in the storage tank.¹⁵

Moreover to simulate real crude distillation unit it is better do not use the TBP already implemented in the simulation package, but always utilize plant data. This because the quality of the same crude can change during the years or as a function of the point of extraction also if it comes from the same oilfield. In this work the TBP curve reported in Figure 3.2, obtained sampling the processed crude was utilized.

The quality of the side stream products is specified by the ASTM D86 distillation curves obtained from the plant laboratory in the period of time selected.¹⁶

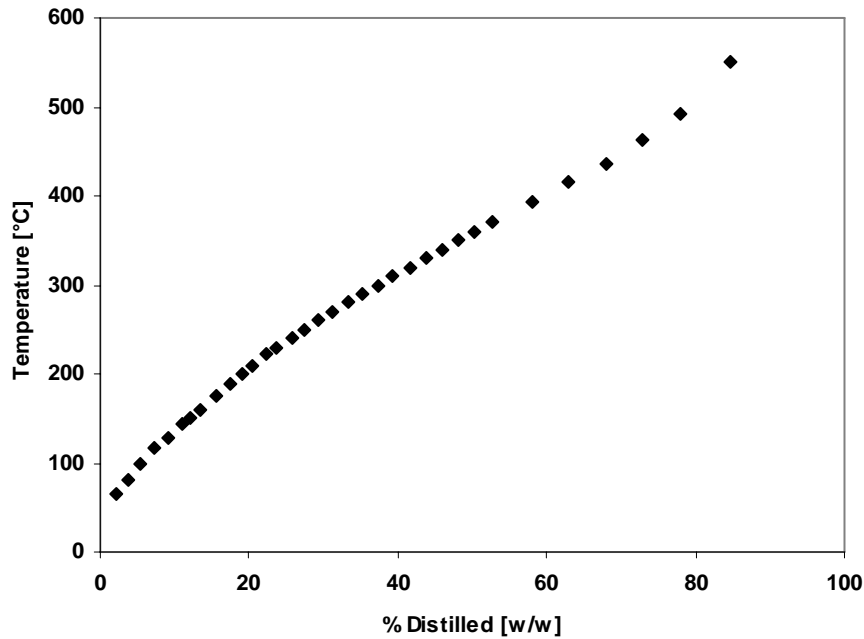

Figure 3.2: TBP curve of the processed crude.

Another important parameter to set is the plate efficiency of the main column; obviously a direct measure is not available, so these data were estimated starting from empirical correlations^{17,18} and used as tuning parameters in a sensitivity analysis performed to match the thermal profile of the column and the composition of the side streams obtained from the plant. To perform this analysis it was necessary to divide the whole column in different sections in coincidence with a variation of the liquid or vapour flow rates corresponding to the pumparounds or the side strippers' locations. Table 3.1 reports the sections and the efficiencies obtained by fitting plant data.

Section	Efficiency
1	0.9
2	0.25
3	0.8
4	0.25
5	0.8
6	0.5

Table 3.1: Section efficiency of the main column.

To choose the thermodynamic model, the following three, usually recommended for petrochemical plants operating at low or medium pressure,¹⁹ were checked:

- BK10
- Chao-Seader
- Grayson-Streed

For all models no significant differences were observed in the prediction of the stream characteristics and so the Grayson-Streed method was utilized in all the simulations.

Figure 3.3-3.6 report the comparison between the plant and the simulated data for products and reflux flow rates, main column temperature profile and Kero and GAL qualities. A good data agreement with a maximum error of 3% was obtained.

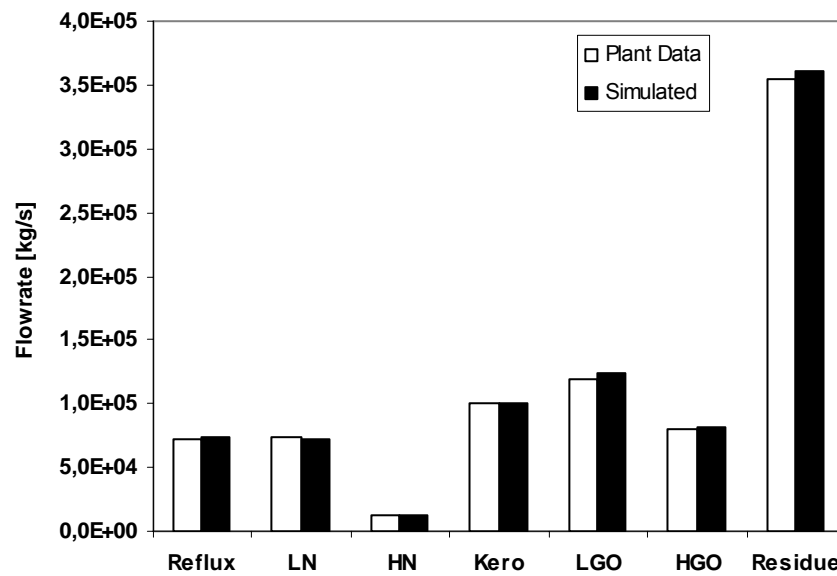

Figure 3.3: Flow-rate comparison between the plant and the simulated data.

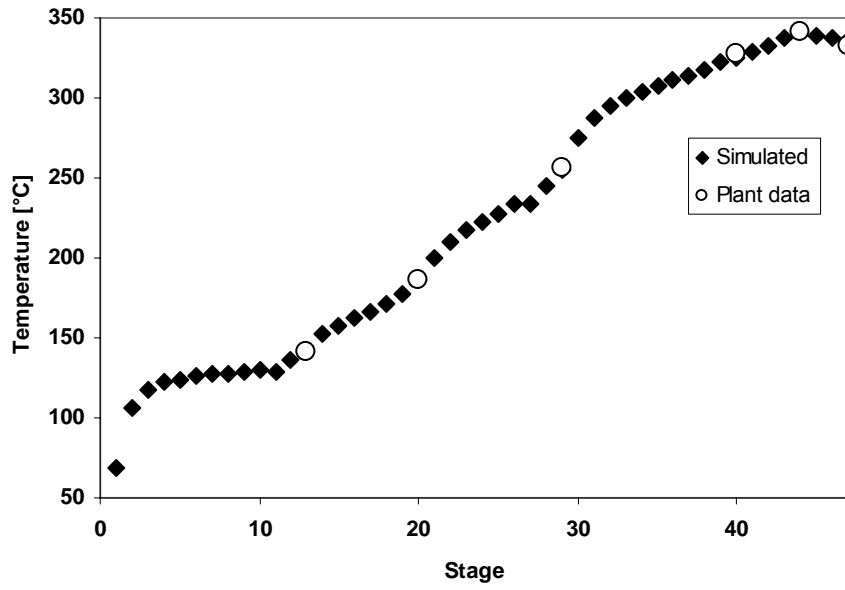

Figure 3.4: Temperature profile of the main column.

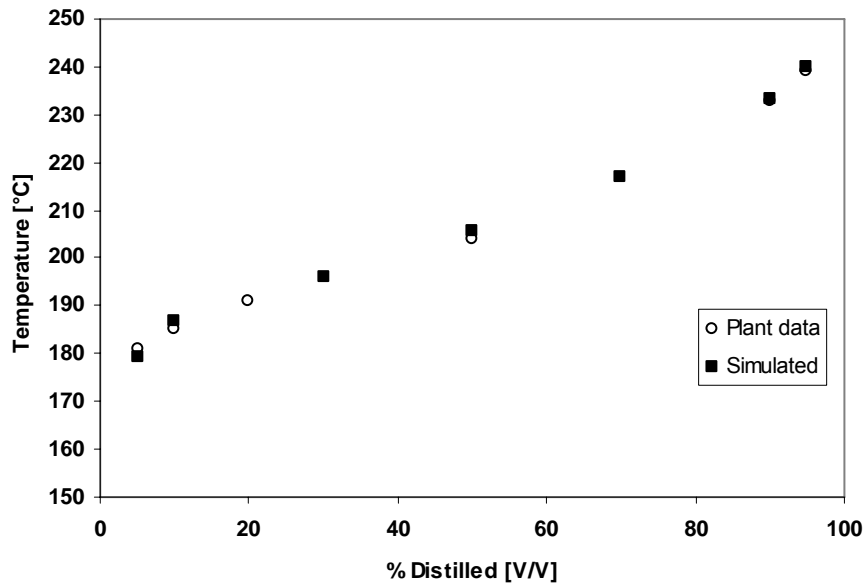

Figure 3.5: ASTM D86 curve for the Kero stream.

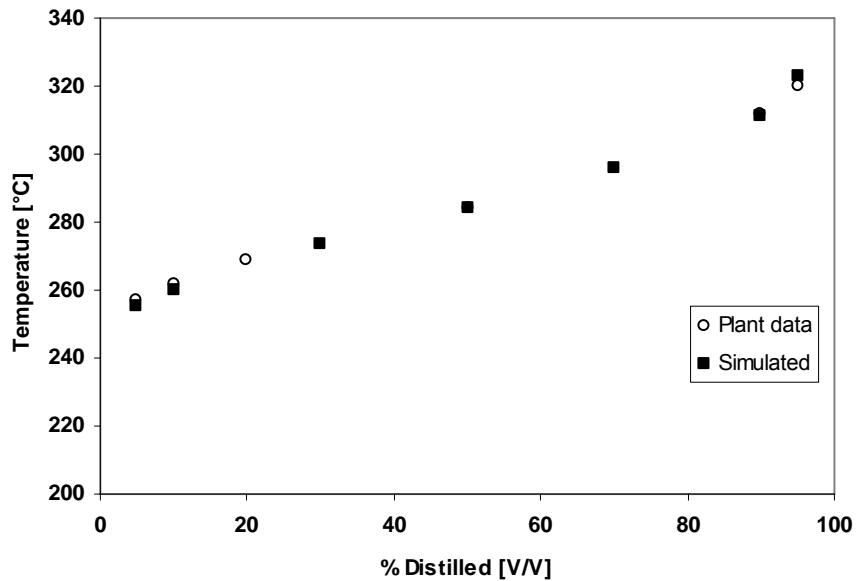

Figure 6: ASTM D86: curve for the GAL stream.

3.3 The Preflashing Devices Options

The different technical solutions that are possible for the preflash implementation can be grouped in two main typologies: preflash drums and preflash towers/columns. The choice between the two types depends on the scope of the revamping work or on the space constrictions of the plant. Usually preflash drums are preferred when it is necessary to increase the capacity of the plant while preflash towers are preferred to improve the naphtha-kerosene separation. In some cases both can improve the heat integration of the plant.²⁰ The main types of device are:

- high or low pressure preflash drum
- preflash tower with naphtha product
- preflash tower with multiple products
- preflash tower with reboiler
- preflash tower and atmospheric tower with shared reflux

The difference between the high or low pressure preflash drum is in the foaming. Usually high pressure preflash drum is preferred when it is necessary to reduce the foaming potential. Anyway the low pressure preflash increases the amount of vaporization. The distinction between high and low pressure is somewhat arbitrary. Typically, a preflash with a pressure floating on the atmospheric column pressure or

operating below 308 kPa (absolute) would be considered a low pressure preflash drum.

The preflash tower with naphtha stripper is the simplest preflash column device with a single product taken from its own reflux drum. Usually it is used to increase the naphtha production or to increase the unit capacity, debottlenecking the atmospheric column overhead or improving the heat integration system. Anyway it is expensive to buy a new column and also the operative costs could be increased for the generation of the preflash reflux.

The preflash column with multiple products is similar to the crude tower. This device is used to reach large increase of capacity but has the disadvantage of the cost of the column and of the necessity of a large plant space.

The preflash tower and atmospheric tower with a shared reflux consist in a common overhead system between the two columns to reduce the capital cost of the investment. Beyond the possibility to increase the capacity of the unity there is the drawback of a heavier reflux in the preflash tower that increases the naphtha load in the atmospheric tower feed and rises the overall cutpoints.

Preflash tower with reboiler is a rare case and is used only when the heat exchanger network is grossly undersized.

More details on the different preflash options can be found in the publication of Sloley²⁰ that gives a whole description of each system, highlighting advantages and disadvantages of each device. In this work two alternatives are considered and compared; a column with a naphtha product and a flash drum at the same pressure of the main column. These alternatives can be considered as the simplest possibilities for a revamping project and are the more applicable solutions to the plant layout. The principal characteristics of these two solutions and the results obtained from the simulations are discussed and compared in the followings paragraphs.

3.3.1 Preflash Drum

The preflash drum is the simplest device to separate light crude compounds before the feed inlet to the main column. This device consists of a simple vessel sized for a mean residence time of about 15-20 minutes to assure a good separation between the liquid and the vapour phase.¹⁰ Particular attention is required during the design to avoid the entrainment of the liquid crude unflashed in the vapour stream. A few useful indications about the principal geometric dimensions of the drum can be found in the Feintuch work.⁵

In our case, considering the layout of the plant, the only possible location for the preflash device is just before the furnace and its temperature is that at the exit of the heat exchanger network.

Thus, all the simulations were made with a preflash temperature of 230°C and with the same pressure of the main column. Another parameter to set is the optimal feed location of the flashed vapour in the main column. There are different possibilities; the most intuitive is to feed the stream just in the tray where the end points of the flashed vapour and of the internal liquid are equal; however in the case of flashed crude entrainment in the vapour stream, there is the risk to obtain black distillates below the feed location.¹⁰ This practical consideration forces the choice to feed the flashed vapour in the flash zone. The flow rates of the main streams and of the furnace duty, obtained in our case considering the system with the flash drum, are reported in Table 3.2 together with those obtained with the preflash column and with the original plant design. From the Table it is possible to note that in the system with the preflash drum there is a lower naphtha production, and a higher Kero, LGO and residue flow rates, while the amount of HGO is unchanged. It is also observed a significant reduction in the furnace duty. These results are obtained increasing the outlet furnace temperature of 5°C to compensate the quench effect of the flashed vapours that are colder than the heated crude from the furnace. We also increased the bottom steam flow rate to compensate the lower carrier effect of the light compounds removed. The increase of the steam flow rate is limited from flooding considerations.

To quantify the cost savings operating with this configuration it is possible to make preliminary calculations by considering indicative costs of the Kero stream and of the fuel oil fed to the furnace. We considered a fuel oil density of 973.7 kg/m³, with a lower heating value of 9767 kcal/kg and an average price of 0.55 €/kg. The average price of Kero is about 576 €/m³. The energy savings were quantified as 7691280 €/y and the earning due to the increased Kero production is of about 6648840 €/y. From this analysis it is possible to conclude that if the plant asset is focused on the production of middle distillates and can be accepted lower naphtha productions, the preflash drum can increase the distillate production and save energy.

3.3.2 Preflash Column

The preflash column, differently from the preflash drum, realizes a real separation and it is possible to set the cut point of the desired product. There are some reported cases of refineries which use a preflash column in their plant or consider this device in a revamping project to unload the atmospheric furnace, to eliminate vaporization at the furnace inlet control valves, to increase the naphtha production and to debottleneck the crude column overhead system.^{21,22}

In our case we consider a bottom steam column with 12 stages and a single liquid product drawn from the condenser. Obviously, from the preflash column condenser,

also part of the fuel gas is removed. The main problems of the preflash column are related to the presence of only a few plates between the flash zone and the withdrawn and the high reflux ratio flow rate.²⁰ Another aspect to consider is the naphtha reduction in the top of the main column. So, if we want to keep the same end point for the naphtha stream, the top temperature decreases with possible condensation phenomena and consequent corrosion possibility. Usually it is better to assure a sufficient column top temperature to avoid corrosion and a long time running apparatus. In our case we choose to fix the top temperature value higher than 100°C. The results obtained with this configuration are reported in Table 3.2. It is evident that there is a high increase in the production of the total naphtha compared to the plant design. Another aspect to note is the improvement of the separation quality. For petrochemical systems where it is not possible to give a discrete component specification, the quality of the separation can be measured by the temperature difference between the 95% vol. and the 5% vol. of the ASTM D86 of two consecutive products.²³ In the plant design this difference between the naphtha and the kerosene products was equal to 1.76, and a gap of 3.10 for the preflash drum design was observed. This value is improved to 16.32 in the preflash column configuration. As a drawback there is a decrease of the Kero production and a smaller reduction of the furnace duty compared to that of the preflash drum solution. It must be noted that the Kero stream is the most important one in the plant asset, but the data to make a comparison between the benefits of an increased naphtha production with respect to a lower value of the Kero flow rate are not available from the plant. However as a general conclusion it appears that the preflash column increases the production of light distillate and improves the naphtha-Kero separation.

Flow rate [kg/h]	Plant Design	Preflash Drum	Preflash Column
Naphtha	84195	79637	117018
Kero	100000	101186	82715
LGO	124000	124422	124000
HGO	82000	82000	82000
Residue	361496	364404	363937
Furnace Duty [kcal/h]	80821092	65231158	79489549

Table 3.2: Comparison between the original plant design, the preflash drum and the preflash column.

3.4 Final Observations

Two revamping solutions for an industrial Crude Distillation Unit are considered in order to identify the better solution to decrease the high energy consumption of the plant. Both a preflash drum and a preflash column were considered and compared for energy savings. Considering an energetic index obtained as the ratio between the furnace duty and the feed flow rate, this value is 104.96 for the plant design, 84.72 for the preflash drum and 103.23 for the preflash column implementation, highlighting the convenience to revamp the plant with the flash drum device. Anyway studying a specific case study the choice of the utilization of one of the considered solutions corresponds to different plant specifications. The preflash drum is the simple device for scope of energy reduction, but some precaution must be considered. First the possibility of crude foaming limits the flashed vapour feed location in the main column. Further there is a quench effect of the cold vapour from the preflash drum and a reduction of the carrier effect due to the light compounds. However the main advantages from the implementation of this solution are the furnace duty reduction and the increased production of the middle distillate. The preflash column operates a preliminary separation and it is not required any refeed in the main column. A high increase of light distillate flow rates can be obtained but smaller energy savings in the furnace duty result, compared to those of the preflash drum configuration. Moreover these two options must be considered together with the different plant requirements. If it is possible to reduce the production of the light distillate and to improve the production of the middle distillate, the preflash drum is the best solution to reach considerable savings in the energy demands. Instead, if the plant production requires a high naphtha production with a high separation performance between this and the Kero stream, the preflash column must be preferred. In both cases the energy savings that can be obtained are related to a reduction in light or middle distillate.

3.5 References

- (1) Bagajewicz, M.; Ji, S. Rigorous procedure for the design of conventional atmospheric crude fractionation units. Part I. Targeting. *Ind. Eng. Chem. Res.* **2001**, 40, 617.
- (2) Linnohff, B.; Hindmarsh, E. The pinch method of heat exchanger networks. *Chem. Eng. Sci.* **1983**, 38, 745.
- (3) Brugma, A.J. The Brugma process *Ref. Nat. Gasoline Manuf.* **1941**, 20, 86.
- (4) Harbert, W. D. Preflash saves energy heat in crude unit. *Hyd. Proc.* **1978**, July, 123.
- (5) Feintuch, H. M.; Peer, V.; Bucukoglu, M. Z. A preflash drum can conserve energy in a crude preheat train. *Energy Prog.* **1985**, 5, 165.
- (6) Yahyaabadi R. Rethink placement of preflash drum in crude preheat train network. *Hyd. Proc.* **2006**, August, 78.
- (7) Yahyaabadi R. Solving hydraulic problems in crude preheat train networks. *Hyd. Proc.* **2005**, November, 89.
- (8) Waintraub, S.; Campos Cauby Coutinho, R.; Oliveira Esposito, R. Preflash drum when processing heavy oils: paradox or reality? *AIChE Spring National Meeting*, **2007**, Houston, Texas, 22-27 April.
- (9) Ji, S.; Bagajewicz, M. Design of crude fractionation units with preflashing or prefractionation: energy targeting. **2002**, *Ind. Eng. Chem. Res.* 41, 3003.
- (10) Golden, S. W. Prevent preflash drum foaming. *Hyd. Proc* **1997**, May, 141
- (11) Ji, S.; Bagajewicz, M. Design of crude distillation plant with vacuum units. I. Targeting. *Ind. Eng. Chem. Res.* **2002**, 41, 6094.
- (12) Whitson, C. H. Characterization hydrocarbon plus fractions *Soc. Pet. Eng. J.* **1983**, Aug. 683.
- (13) Riazi, M. R. A continuous model for C7+ fraction characterization of petroleum fluids *Ind. Eng. Chem. Res.* **1997**, 36, 4299.
- (14) Vakili-Nezhaad, G. R.; Modarress, H.; Mansoori, G. A. Continuous thermodynamics of petroleum fluids fractions *Chem. Eng. Proc.* **2001**, 40, 431.
- (15) Bath, S; Chatterjee, T.; Saraf, D.N. On-line data processing and product properties prediction for crude distillation units. *AIChE Spring National Meeting*, **2003**, New Orleans, Louisiana, March 30-April 3.
- (16) Saliu, A.; Baratti, R.; Melis, S. Data analysis in modelling distillation crude units *ICheaP-5*, **2001**, Florence, May 20-23.
- (17) McFarland, S. A.; Sigmund, P. M.; Van Winkle, M. Predict distillation efficiency. *Hyd. Proc.* **1972**, July, 111
- (18) Jacimovic, B. M.; Genic, S. B. Use a new approach to find Murphree tray efficiency. *Chem. Eng. Prog.* **1996**, August, 46.

- (19) Aspen Plus 13 User Models, Aspen Technology, Inc.
- (20) Sloley, A. Crude Petroleum Distillation. The Distillation Group, Inc. **2002**.
- (21) Martin, G .R. Keeping down the cost of the revamp investment. *Petr. Tech. Quat.* **1999**, Summer Issue, 99.
- (22) Barletta. T.; Martin, G. R. Consider comprehensive CPD efforts to cut costs. *Hyd. Proc.* **2002**, June, 53.
- (23) Jones, D.S.J Elements of petroleum processing; John Wiley & Sons Ltd.; England, **1995**

Chapter 4

Process Intensification of a Light-Ends Plant

In this chapter, a case study for the reduction of the energy load in a real industrial process is presented. Different tools can be employed to reach the scope. In the CDU a new apparatus to decrease the heat supply to the furnace was considered, in this case the employment of a new technology was applied together with some process limitations. Here the goal of energy reduction is studied imposing also minimum plant modifications.

4.1 Introduction

The previous retrofit study was based on a plant modification realized adding a new equipment to achieve the retrofit scope of energy load reduction. Also in this case the retrofit scope is the decrease of the energy consumption of the considered plant, but the scope is reached using a different available technology. This observation begins from the consideration that every equipment in an existing plant was built using the know-how available in that specific moment. At the time of the retrofit work, new methodologies or new technologies could be available and their utilization could bring to large benefits for the retrofit scope.

The new trend in the distillation, revamping or new design, is the employing of thermal coupled structures to reduce the thermodynamic irreversibility intrinsic in the separation method. It is known that conventional distillation trains are widely used in the chemical industry. These configurations use simple columns with one feed and two product streams. The first thermodynamic inefficiency comes from the irreversible mixing in non-identical streams. Simple column configurations are forced to sacrifice the efficiency to reach the requested product purity in a multicomponent separation. Considering, for example, the separation of a stream containing butane, pentane, hexane and heptane, the separation can be realized in different ways according to the order of separation of the components. In any case, considering the sequence that realizes the separation from the lightest component first to the heaviest one, Figure 4.1 reports the molar profile in the liquid phase for the pentane in the first column.

It is possible to notice that the composition of the component reaches a maximum near the bottom of the column but because the component has not been removed it is remixed and diluted at the concentration at which is withdrawn from the bottom of the column. Some energy is used to separate the component to the maximum purity, but this energy is lost and for this reason the remixing effect leads to a thermal inefficiency. Another possible source of inefficiency is the difference in the composition between the feed stream and the liquid composition at the feed tray also after the optimization of the feed location. The use of thermally coupled structures can minimize the mixing losses promoting a greater interaction between vapour and liquid streams. A thermal coupling, as better explained in the following paragraphs, is obtained by excluding a condenser, a reboiler or both and to replace them by two interconnecting vapour and liquid streams between the columns. The result is an improvement of the energy efficiency of about 10-30% and a decrease of the capital cost due to less number of equipments needed.

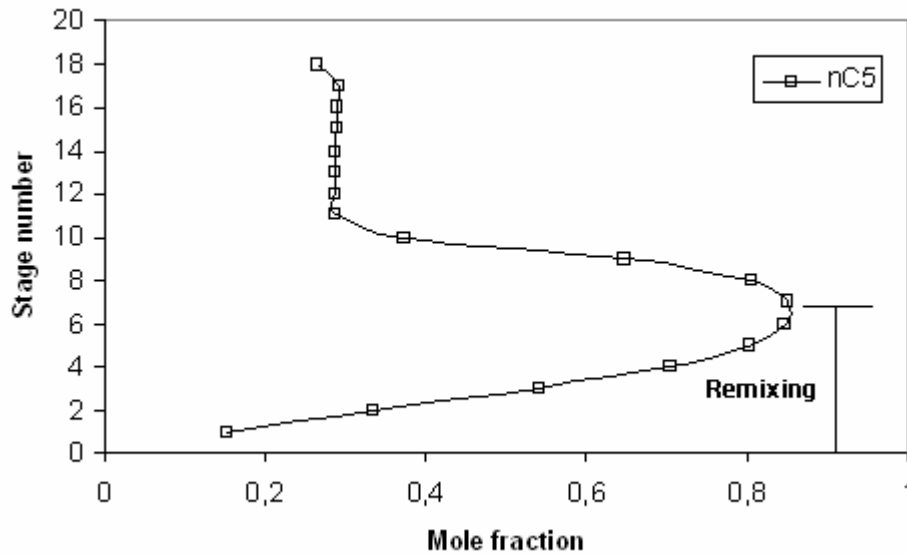

Figure 4.1: Remixing effect of one middle component in a conventional direct distillation sequence.

4.2 Review in Distillation Trends

As said before, since the energy crisis of 1970s, energy conservation has been a research field of increasing interest for chemical engineers to develop new methods for improving the energy efficiency of different plants.

Recent trends in energy saving with regards to the optimization of distillation sequences, and the most significant developments in this field, are the applications of thermally coupled sequences¹ and of divided wall columns.²

In particular many studies in this field have been devoted to chemical and petrochemical plants that utilize high energy-intensive processes, and distillation is by far the most widely used separation method to obtain pure components from an initial multicomponent mixture. The possibility to lower the energy demand of the process increases plant earnings and also reduces pollution emissions resulting from the less energy usage.

Among the alternative techniques for the retrofit of conventional distillation schemes, recent studies^{3,4} showed that the thermal coupling technique is one of the most promising options. On one hand, it is implemented by directly eliminating some condensers and reboilers of the traditional distillation configurations and on the other hand, it provides the potential to save both energy and capital costs. Moreover, it is shown that in certain cases, the thermally coupled configurations can outperform traditional simple column configurations in terms of dynamic responses.⁵⁻⁷

The research about thermally coupled sequences can follow two main approaches, the first is to search all the possible configurations that can be generated from a n -component mixture and after that, with optimisation methods like MNLP, the better configuration can be chosen by the solution of the superstructure that contains all the possible connections between the columns.^{3,8,9} To create a good superstructure is a difficult task and sometimes not all the column configurations are considered and compared.¹⁰ The second method considers the synthesis of new structures obtained in terms of the intended individual splits and their comparison in terms of energy and capital costs.¹¹⁻¹³ Beside the researches that follow these two methods, other groups studied the control problems and the dynamics performance of the thermally coupled systems^{6,14} or developed short cut design methods.^{15,16}

Traditional distillation plants usually include only simple columns, thus each column has a single feed, one condenser and one reboiler. For n -component mixtures each simple column configuration has $2(n-1)$ condensers and reboilers, but only n of these are utilized to obtain the products with the specified purity. The remaining $(n-2)$ exchangers are utilized for internal submixtures of two or more components. According to the definition of Caballero and Grossmann⁸ we call exchangers of class I those associated to an internal submixture and exchangers of class II those associated to the product streams that leave the system considered.

It is known that in exchangers of class I, a remixing takes place and this is the cause of a drop in the separation efficiency.¹⁷ The separation inefficiency can be avoided by substituting these $(n-2)$ condensers and reboilers with a vapour-liquid interconnection between the columns.¹

In this work, the retrofit of the separation plant of a light ends stream from a crude distillation unit is studied. The four components feed of normal paraffin from butane to heptane is separated in four streams with different purities as required by the plant specification.

Since the majority of the plant was built before the energy crisis, only simple columns were used. Starting from a simple column configuration (SC) and applying the thermal coupling technique, it is possible to obtain two thermally coupled groups of configurations: the partially thermally coupled (PC) schemes and the fully thermally coupled (FC) schemes or Petlyuk columns. In the former, the configurations are characterized by a lower number of condensers and/or reboilers with respect to the SC configurations. In the latter, discovered about 60 years ago for the separation of a three component mixture¹⁸ and recently applied for the separation of four or more component mixtures,¹⁹⁻²¹ we have the minimum possible number of heat exchangers. In PC schemes, only heat exchangers of class I are removed, while in FC configurations class II heat exchangers are also eliminated. This is one of the main differences between the two thermally coupled group of configurations.

It is known that the implementation of FC structures can give a 30% saving in energy costs, with also a considerable economy in capital costs.^{15,22,23} However, fully thermally coupled distillation systems are rarely used in industrial cases, with the exception of a few German,²⁴ Japanese,²⁵ British,²⁶ and American²⁷ applications, probably due to difficulties in the control of the system and to the lack of knowledge in the start-up operations.²⁸ For all these reasons in this work only PC schemes are studied as alternatives to the plant configuration. In addition, a retrofit work with PC schemes makes possible to obtain a higher reuse of the existing equipments compared to FC schemes.

From the possible SC schemes for a multicomponent separation, we can map a subspace of configurations where thermal coupling is not introduced simultaneously for all the submixtures. In this case, it is possible to generate different multicomponent flowsheets with different numbers of thermal couplings.⁴ This subspace is a very important issue for retrofit works because it represents a class of sequences with a minimum modification of the plant, which makes it a good candidate to match both energy saving and less plant modification.

Retrofit of distillation columns represents an important issue for energy savings through the maximization in the usage of the existing equipment.²⁹ Gundersen³⁰ has evaluated that at the end of 80's about 70-80% of the capital investment projects in the process industry were retrofit projects.

The aim of this chapter is to study the optimal retrofit of a real industrial distillation plant taking into consideration both energy consumptions and capital costs. The target is not just to identify the best solution in terms of Total Annual Cost (TAC) like in the design of a new plant, but the solution that matches energy savings with a maximum usage of the existing equipments, such as trays, exchangers and columns. A detailed comparison in terms of energy consumption, heat exchanger area, and column section reuse is performed for the different considered configurations in order to identify the best solution.

4.3 Generation of the Retrofit Alternative Configurations from the Existing Plant

It is known that for the separation of pure components from a n-component mixture, (n-1) simple columns are needed. Different distillation sequences can be utilized according to different orders in the component separation. Thompson and King³¹ reported the following formula to calculate the number S_n of all the simple configurations for a n-component mixture.

$$S_n = \frac{[2(n-1)]!}{n!(n-1)!} \quad (4.1)$$

The plant configuration considered in our case for the separation of the mixture reported in Table 4.1, is showed in Figure 4.2. This configuration can be classified as a direct-indirect sequence where the lightest component is removed first, followed by the removal of the heaviest component, and finally the two remaining components are separated. The sequence can be represented by the following separation task: A/BCD; BC/D; B/C.

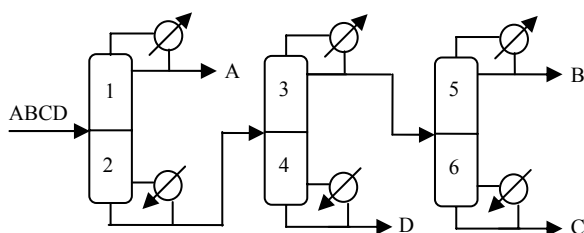

Figure 4.2: Plant configuration.

Component	Molar Flow [kmol/h]	Physical Characteristic	
A, n-Butane	280	Temperature [°C]	128
B, n-Pentane	300	Pressure [atm]	5
C, n-Hexane	140		
D, n-Heptane	530		

Table 4.1: Feed characterization.

Other four simple configurations, as expected from eq 4.1, are possible for this separation, the direct (A/BCD; B/CD; C/D) and the indirect (ABC/D; AB/C; A/B) sequences, the indirect-direct (ABC/D; A/BC; B/C) sequence and the distributed sequence (AB/CD; A/B; C/D). These configurations were already considered and compared in terms of energy consumption and TAC in a previous work.³²

In that work it was shown that, for this existing distillation plant, the thermally coupled configurations have significant savings on both energy consumption and TAC.

It must be noted that the previous work only considered such thermally coupled configurations where all the possible thermal couplings have been introduced. These solutions require the maximum modifications of the conventional simple column configurations. However, from the existing plant configuration, it is possible to

generate thermally coupled configurations with a lower number of thermal couplings. These configurations have the distinct feature to require small modifications of the existing distillation plant and to favour the reduction of the capital investment. However the configurations have the potential to allow energy savings similar to those with all possible thermal couplings introduced.

The total number of possible configurations from a single simple sequence, for a mixture of four or more components was predicted by Rong and Kraslawski.⁴

$$C_n = \sum_{j=1}^{n-3} \frac{(n-2)!}{j!(n-2-j)!} + 1 \quad (4.2)$$

It is easy to see that for a four component separation the following are the three configurations with thermal couplings can be utilized.

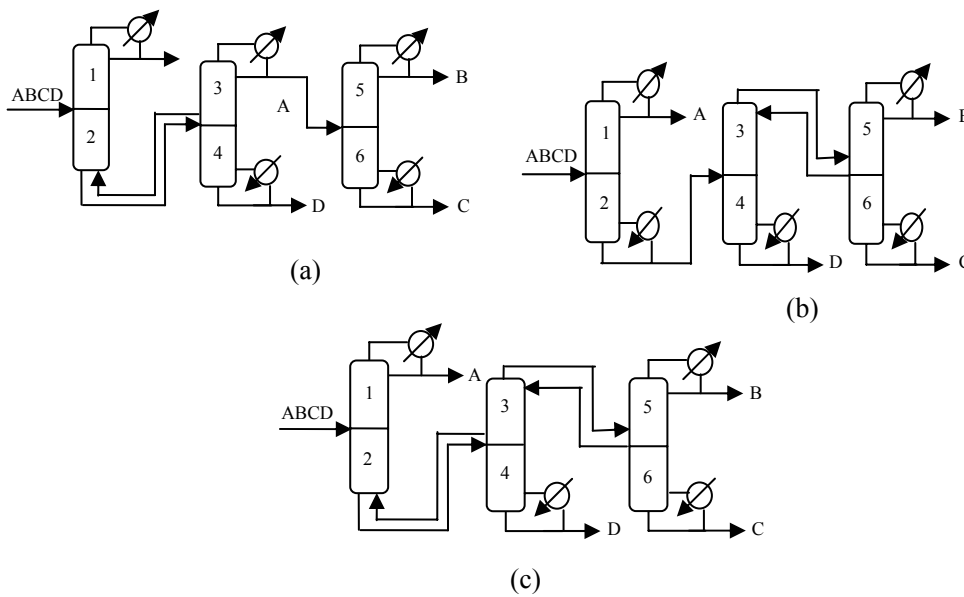

Figure 4.3: Original thermally coupled sequences obtained from Fig.4.2.

Figure 4.3a shows the configuration obtained from the plant design of Figure 4.2, by removing the reboiler of the first column associated to the submixture BCD. Figure 4.3b is obtained by removing only the condenser of the second column associated to the submixture BC, and in Figure 4.3c both the condenser and the reboiler are substituted with thermal couplings. All these configurations form the family of the original partially thermally coupled (OPC) schemes. Defining a column section as a portion of a distillation column that is not interrupted by entering streams or heat flows,³³ each section was numbered as reported in the figures. By examining the

OPC schemes some considerations can be made to construct the thermodynamically equivalent configurations reported in Figure 4.4.

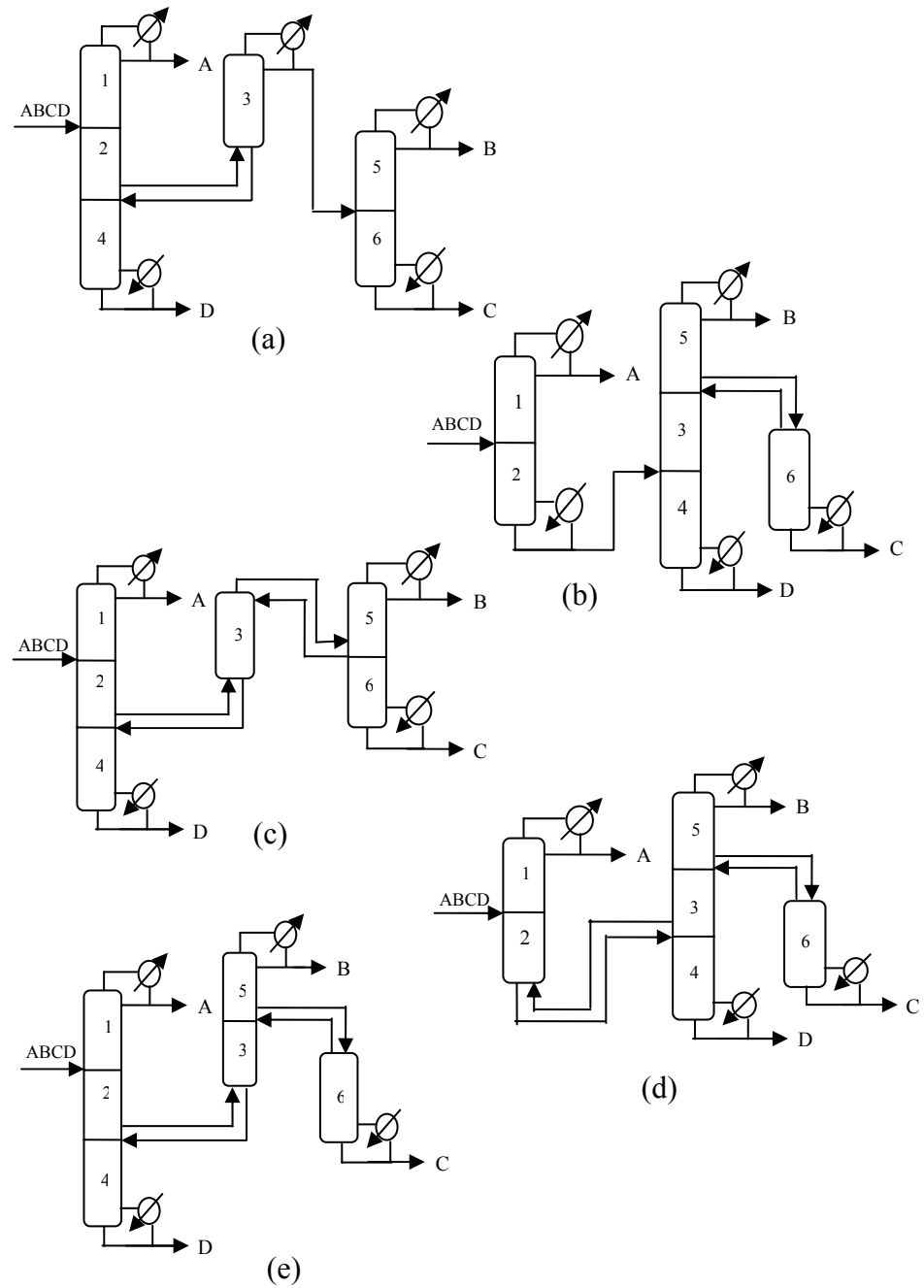

Figure 4.4: Thermodynamically equivalent structures obtained from Fig.4.3.

In Figure 4.3b, the liquid reflux flow rate of the second column is provided from the same condenser of the rectifying section of the third column and identified by the number 5, thus the rectifying section 5 can be moved above the section 3 of the second column.

Similar considerations can be applied to the reboiler or to the condenser and the reboiler at the same time. The number of column sections that can be moved strictly depends on the number of thermal couplings. For a SC n -component distillation, $(n-2)$ thermal couplings can be introduced, so $(n-2)$ column sections are movable; in our case sections 4 and 5 are movable and the new five configurations reported in Figure 4.4 can be obtained. In particular configuration 4.4a is derived from the 4.3a, the 4.4b from 4.3b and 4.4c, 4.4d and 4.4e from the 4.3c. These configurations are called thermodynamically equivalent structures (TES), have the same energy consumption of the OPC from which they are derived and could mitigate the uneven distribution of vapour and liquid flows within the OPC. For this reason with the TESs it is possible to obtain a better column equipment design, a higher hydraulic performance³⁴ and more operable structures with respect to the vapour transfer between the columns.²³

4.4 Simulation and Results

All the configurations shown in Figures 4.2, 4.3 and 4.4 were simulated for the required molar purity of 85% for the components A and B, 89% for C and 98% for D. All the simulations were performed by means of the rigorous RADFRAC model implemented in the software Aspen Plus 13.0 in order to obtain the data to evaluate capital costs and energy consumptions. The Wilson equation was adopted for the calculation of the activity coefficients of the liquid phase, whereas ideal behaviour was assumed for the vapour phase. The real plant, represented in Figure 4.2 consists of three columns. The first column has 28 trays with a diameter of 2.5 m, the second one has 42 trays and a diameter of 3 m and the third one has 34 trays and a diameter of 2 m. Single pass sieve trays were considered with a downcomer area, expressed as a fraction of the total tray area, equal to 0.1. The tray spacing was 0.61m. The plant was simulated with a pressure of 5 atm for each column, the column pressure drop and other relevant parameters are given in Table 4.2.

The simulation of the existing plant was checked for temperature profiles, product flow rates, molar purities, condenser and reboiler duties and column diameters. Good agreement was obtained between the model and the values measured in the plant; the difference between these values never exceeds 5%.

	Column 1	Column 2	Column 3
D [kmol/h]	285.80	451.90	303.90
B[kmol/h]	964.20	512.30	148.0
P_T [kPa]	507	507	507
P_B [kPa]	518	526	521
T_T [K]	328	368	355
T_F [K]	401	396	368
T_B [K]	396	439	407
RR	3.80	1.42	1.30
N	28	42	34
N_f	17	21	16
N_t	18	29	23
d [m]	2.5	3.0	2.0

Table 4.2: Plant design parameters

The simulations of the OPC configurations reported in Figure 4.3 and of the TES reported in Figure 4.4 were performed starting from the conventional distillation sequence. The original distillation sections were properly connected in the new configurations, assuming the same number of trays. The structures are then optimized for the minimum energy consumption utilizing the interconnecting streams (liquid and/or vapour) as searching variables for the optimization procedure.^{35,36}

From the simulations we obtained all the data necessary to make cost calculations, like the column diameter, the reboiler and the condenser duties.

The area of condensers and the reboilers was evaluated from the usual design formula:³⁷

$$A = \frac{3600 \cdot Q_{c/r}}{U_d \Delta T_{LM}} \quad (4.3)$$

A mean value of 1800 kJ/m² h °C and 2100 kJ/m² h °C for U_d of condensers and reboilers respectively, was assumed. The columns tray and shell costs were evaluated according to the Douglas book correlations reported in Appendix A.³⁸

All the capital costs were updated to year 2006 by the Marshall & Swift index.³⁹ The column height (H) was evaluated, according to eq 4.4, by considering the actual number of trays (N), a tray spacing fixed at 0.6 m and a value of 6 m for the space necessary for the vapour disengagement at the top of the columns and for the bottom liquid level. For the generated thermally coupled configurations, this value was

halved if only a condenser or a reboiler was removed, or it was not accounted for if the column does not have both reboiler and condenser.

$$H = (N-1)*0.6 + 6 \quad (4.4)$$

The theoretical number of trays was estimated from the actual number of trays by evaluating the tray efficiency of every column section according to simplified equations.⁴⁰

The operating costs were evaluated by considering the European prices of the energy reported in Table 4.3. Different quality of steam is taken into account according to the bottom temperature.⁴¹ A minimum temperature difference between the auxiliary and the process fluid of 10°C and an annual running time of 8000 h/yr were also assumed.

Utility	Temperature Level [°C]	Price [\$/ton]
LP-steam	144	13
MP-steam	184	16
HP-steam	254	20
Cooling water	20-40	0.082

Table 4.3: Utilities cost data.

A retrofit study includes various steps, starting from the analysis of the bottlenecks of the existing process.⁴² In this work the emphasis is on the reduction of energy usage, and this criterion is first used to choose among the proposed alternatives. Then, for the alternatives with the maximum energy savings, the possibility to reuse the eliminated condenser and/or reboiler of the simple columns in the original plant is evaluated.

In order to obtain a first comparison between the new configurations proposed, Figure 4.5 reports the total condenser and reboiler duties for some of the considered sequences. Only the OPC schemes are reported because, as pointed out in the previous section, the TESs have the same energy consumption. From the figure it appears that all the thermally coupled schemes are able to reduce the energy consumption with respect to the plant design. In particular, configurations 4.3b and 4.3c achieve a saving of about 23% in the reboiler duty.

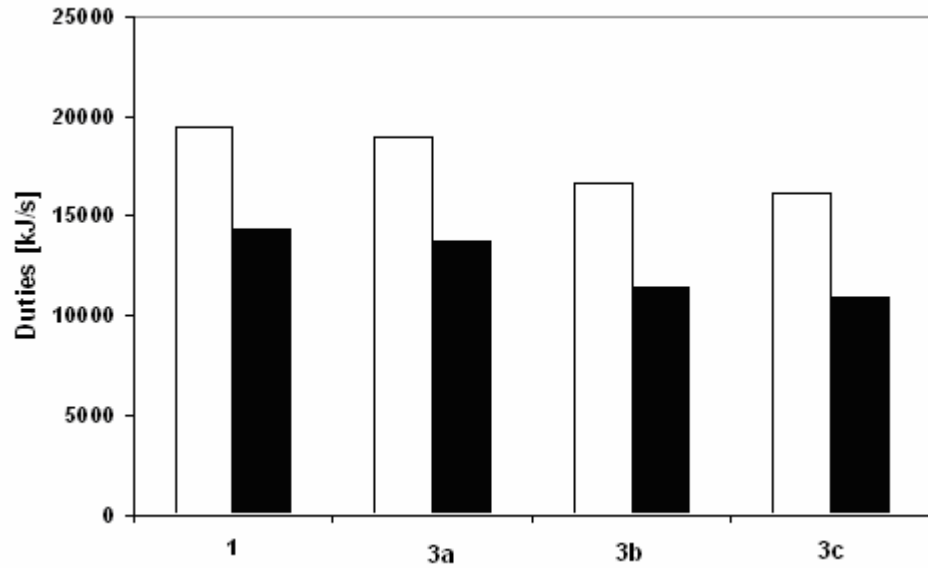

Figure 4.5: Condenser (empty bars) and reboiler (full bars) for the plant design and the OPC sequences.

Table 4.4 reports the main operating and equipment simulated parameters for the existing plant, like the number of trays, the column diameter, the maximum liquid and vapour flows and the condenser or reboiler duty associated with each section. From this table it is possible to observe that there is a large difference between the liquid and vapour flows in the sections of the same column.

Section	N_t	d [m]	L_{\max} [kg/s]	V_{\max} [kg/s]	$Q_{c/r}$ [kW]
1	11	2.44	18.85	23.54	7753.63
2	7	2.44	26.89	2.94	1253.53
3	15	3.22	13.61	22.96	7482.12
4	14	3.22	47.24	32.63	8576.08
5	11	2.01	7.64	13.46	4249.36
6	12	2.01	19.31	15.79	4458.89

Table 4.4: Design parameters from the simulation of the plant design of Figure 4.1.

In particular the difference among the vapour flow rate of the first column (sections 1 and 2) and the liquid flow rate of the second (sections 3 and 4) and the third (sections 5 and 6) ones is evident. This is an indicator that, different column diameters must be considered, so for all the new configurations proposed the diameter of every column section was evaluated considering vapour velocities with a fraction of flooding equal be 0.8. The flooding velocity was estimated from the correlation given by Fair⁴⁵ and available from the simulation package utilized. It is

also important to compare the required heat exchanger area. Tables 4.5 and 4.6 report respectively the heat exchanger area and the column section diameter for the selected configurations. A detailed comparison about energy saving and equipment reutilization is reported in the following part in order to approach the optimal solution with both significant energy saving and low capital investment.

4.5 Discussion

In order to compare the different proposed retrofit alternatives and to choose the best one, different parameters can be checked. These parameters are the energy savings obtained, the possibility to reuse the heat exchanger from the original plant design and also the column sections. In the following paragraphs, the influence of these parameters is discussed in detail

4.5.1 Energy Savings

The energy comparison is usually performed considering the sum of the reboiler and condenser duties. These values should be used only for a preliminary screening, in fact for a more complete analysis, the quality (i.e. low, medium or high pressure vapour) of the heat required for the separation, must be taken into account. For this reason also the operating costs for the plant design and for the OPC schemes were evaluated and reported in Figure 4.6.

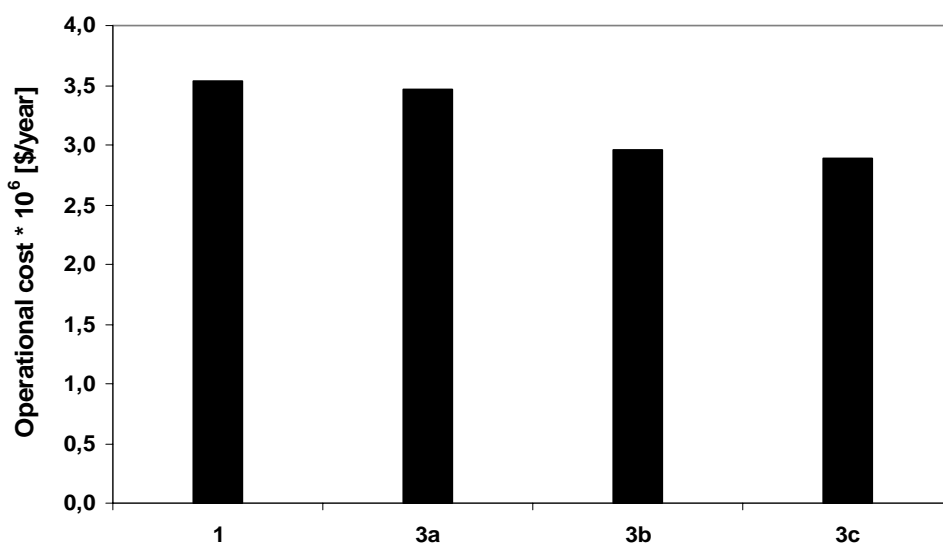

Figure 4.6: Operational costs for the plant design and for the OPC sequences.

It is evident that the configuration 4.3a has a similar energy requirement of the plant design, then this configuration obtained by removing the reboiler from the first column of the plant design, is not a good candidate for the retrofit of the existing plant. Also the configuration 4.4a, obtained from the scheme 4.3a through recombination of the column sections, has the same energy requirement; so these two configurations were not considered for the exchanger area and the column section comparison. It can be concluded that from the energy point of view, the schemes 4.3b, 4.3c and the corresponding TESs (4.4b, 4.4c, 4.4d, 4.4e) are the promising alternatives for the retrofit of the existing plant.

4.5.2 Heat Exchanger Area Comparison and Selection

For those retrofit alternatives with significant savings on the energy consumption, it is worthwhile to search the optimal solution that maximises the utilization of the existing equipment. Table 4.5 reports the exchanger area requirement for the selected configurations; it appears that to maximize the use of the existing equipment it is possible to utilize the eliminated exchangers of the thermally coupled configurations to reach the required value of the exchanger area.

Column	1		2		3		
	Ac	Ar	Ac	Ar	Ac	Ar	
Configuration	1	662.7	100.5	233.5	799.0	164.3	786.8
	3b	662.7	100.5	0	799.0	343.4	283.9
	3c	662.7	0	0	869.8	361.7	292.3

Table 4.5: Condensers and reboilers area for the plant design and for the selected configurations.

For configuration 4.3b, the whole equipment of the first column can be completely reused, so as the reboiler of the second one. The condenser of the third column requires an area of 348.4 m² that can be obtained as the sum of the corresponding condenser of the plant design plus the eliminated condenser of the second column due to the thermal coupling. The reboiler of the last column in Figure 4.3b requires an area of 283.9 m², but in the plant we dispose of a 786.8 m² one, which can be readapted for the reuse.

For configuration 4.3c, where both the condenser and the reboiler associated to the internal submixtures are removed, the heat exchangers of the first column are the

same as those of the plant design. The required area of 869.8 m² for the reboiler of the second column can be obtained as the sum of the corresponding reboiler of the plant design and the one eliminated with the first thermal coupling. The same consideration can be made for the condenser of the third column. Also in this case the reboiler available for the third column is oversized with respect to the requirement of the modified configuration. Obviously the exchanger area of the TESs is the same of the corresponding OPCs. It must be pointed out that the variation in the utility flow rate also affects the global exchange coefficient and the pressure drop, but these two parameters were not taken into account in this preliminary study.

From the exchanger area comparison it can be concluded that the retrofit alternatives that satisfy the energy savings also have the maximum usage of the plant design equipments.

4.5.3 Section Diameter Comparison and Selection

The last comparison concerns the possibility to reuse the plant column sections. Now, it is necessary to compare simultaneously the OPCs and the TESs, because the thermodynamically equivalent configurations give the opportunity to have a better vapour and liquid distribution in the columns. To compare the possibility to reuse the plant column sections for the retrofit alternatives, the flooding factor was checked to analyse the hydraulic performance. Table 4.6 reports the column diameter for every column section of the selected configurations.

Configuration	Section diameter [m]					
	1	2	3	4	5	6
3b	2.44	1.59	2.31	3.21	2.71	1.20
3c	2.44	1.64	2.20	3.38	2.62	1.22
4b	2.44	1.59	2.28	3.21	2.71	1.20
4c	2.44	1.64	2.20	3.37	2.62	1.22
4d	2.44	1.64	2.19	3.38	2.62	1.24
4e	2.44	1.64	2.34	3.38	2.62	1.22

Table 4.6: Column section diameters for the selected configurations.

For the configuration 4.3b, it is possible to operate with the first two plant columns, but for the third one the diameter required for the section 5 is too high with respect to that available in the plant (the flooding factor would be 1.25), so for the section 5 it is necessary to buy new trays. For configuration 4.3c the same considerations are valid and also in this case the section 5 should be built as a new section. A correspondent investment of about 87000 \$ was estimated.

The group of configurations from 4.4b to 4.4e has the common element of containing at least one column with three column sections. For these columns the only flooding factor analysis to check the possible reuse of the plant column sections is not sufficient. We must also consider the practical limitation in the maximum number of diameter changes in the same column. Usually in the industrial practice this number is two, and thus we consider only columns with no more than two different column diameters between consecutive column sections.

For configurations 4.4b and 4.4d, column one can be used directly from the plant, the second column can be used for sections 3 and 4 and a part of the third one for section 6, but due to flooding limitation the remaining plates of 2.01 m from the plant design can not be used, so section 5 should be built as new. The required investment is equal to that of 4.3b and 4.3c cases.

In configuration 4.4c and 4.4e, the first column has three sections, for the first two sections it is possible to operate with the first column of the plant design adding the section 4 from the plant design. For section 3, 15 plates of 2.01 m from the third column of the plant can be used, for section 5 it is possible to utilize plates of 3.22 m and for section 6 the 2.01 ones. The investment requires new plates of 2.01 m for section 3 and is of about 18000 \$

In conclusion sequences 4.3b, 4.3c, 4.4b and 4.4d require a new column section with a correspondent investment of about 87000 \$. For configuration 3c and 3e an investment of 18000 \$ was evaluated.

The choice of the best solution is a complicated task and a comparison based on only the needed investment is not sufficient because many factors can not be expressed in a quantitative way. Considering for example configurations 4.4c and 4.4e, an investment of 18000 \$ is needed. This is a really low investment but we did not consider the cost for cutting the columns and the time needed for the column readapting. Moreover, all the TESs operate with a column composed of three sections instead of two like in the original plant and this requires the verification of the fundamentals.

4.6 Conclusions

In this chapter, the retrofit of a multicomponent distillation process for a real industrial operation plant is studied. Starting from the existing distillation plant of the simple column configuration, the emphasis for the retrofit has been set on the maximum saving of energy, as well as the maximum reuse of the pieces of the existing equipment in the distillation plant.

To this aim, different possible partially thermally coupled (OPC) configurations and their possible thermodynamically equivalent structures (TES) were derived from the existing plant configuration.

All derived configurations were first compared in terms of energy savings. Then, the alternatives with the maximum energy savings were selected for further investigation of equipment design. This was done by a detailed comparison of heat exchangers areas and column sections to identify the maximum usage of the existing equipment. Only the investment for the new equipment was evaluated because data on the cost of readapting the old one were not available. Usually these information were done during consultation meetings with process engineers and the collaboration between different working positions inside the plant is a crucial point for the success of any retrofit project.

In our case configurations 4.3b and 4.3c require only the modification of one column from the plant design. For configurations 4.4b, 4.4d and 4.4c, 4.4e we need to readapt two and three columns, respectively. Thus, the best solutions, in terms of energy savings and minimum plant modifications for the retrofit of the existing plant, are the OPC configurations shown in Figures 4.3b and 4.3c. Both the configurations have comparable energy savings, need only one column cutting and no substantial retrofit is required. In particular configuration 4.3b, obtained by removing the condenser of the second column of the plant design with a single thermal coupling, requires a small modification of the original plant and satisfies the objective of the retrofit work for maximum utilization of the existing plant equipment. Moreover, compared to configuration 4.3c, where two thermal couplings are introduced, configuration 4.3b has also the benefits of a better controllability and operability.

4.7 Notation

- A = exchanger area [m^2]
B = residue flowrate [kmol/h]
 C_n = number of thermally coupled schemes for a simple column sequence
d = distillation column diameter [m]
D = distillate flowrate [kmol/h]
H = column height [m]
 L_{\max} = maximum value of the liquid flow in a column section [kg/s]
N = number of actual trays
 N_f = feed location
 N_t = number of theoretical trays
 P_B = column bottom pressure [kPa]
 P_T = column top pressure [kPa]
 $Q_{c/r}$ = condenser/reboiler duty [kJ/h]
RR = molar reflux ratio
 S_n = number of simple column sequence for a n-component mixture
 T_B = column bottom temperature [K]
 T_F = column feed temperature [K]
 T_T = column top temperature [K]
 U_d = average exchange coefficient [$\text{kJ/m}^2 \text{ h } ^\circ\text{C}$]
 V_{\max} = maximum value of the vapor flow in a column section [kg/s]
 ΔT_{LM} = logarithmic mean temperature difference

4.8 References

- (1) Petlyuk, F. B.; Platonov, V. M.; Slavinskii D. M. Thermodynamically Optimal Method for Separating Multicomponent Mixtures. *Int. Chem. Eng.* **1965**, 5, 555.
- (2) Becker, H.; Godorr, S.; Kreis, H.; Vaughan, J. Partitioned Distillation Columns - Why, When & How. *Chem. Eng.* **2001**, 108, 68.
- (3) Fidkowski, Z. T. Distillation Configurations and Their Energy Requirements. *AIChE J.* **2006**, 52, 2098.
- (4) Rong, B. G.; Kraslawski, A. Optimal Design of Distillation Flowsheets with a Lower Number of Thermal Couplings for Multicomponent Separations. *Ind. Eng. Chem. Res.* **2002**, 41, 5716.
- (5) Segovia-Hernandez, J. G.; Ledezma-Martinez, M.; Carrera-Rodriguez, M.; Hernandez, S. Controllability Analysis of Thermally Coupled Distillation Systems: Five Component Mixtures. *Ind. Eng. Chem. Res.* **2007**, 46, 211.

- (6) Segovia-Hernández, J. G.; Hernández, S. Dynamic Behavior of Thermally Coupled Distillation Configurations for the Separation of Multicomponent Mixtures. *Chem. Biochem. Eng. Q.* **2006**, 20, 125.
- (7) Esparza-Hernandez, F.; Irianda-Araujo, C. Y.; Dominguez-Lira, L. M.; Hernandez, S.; Jiménez, A. Feedback Control Analysis of Thermally Coupled Distillation Sequences for Four-Component Mixtures. *Chem. Eng. Res. Des.* **2005**, 83, 1145.
- (8) Caballero, J. A.; Grossmann, I. E. Thermodynamically Equivalent Configurations for Thermally Coupled Distillation. *AIChE J.* **2003**, 49, 2864.
- (9) Agrawal, R. Synthesis of Multicomponent Distillation Column Configurations. *AIChE J.* **2003**, 49, 379.
- (10) Agrawal, R. Synthesis of Distillation Column Configurations for a Multicomponent Separation. *Ind. Eng. Chem. Res.* **1996**, 35, 1059.
- (11) Rong, B. G.; Kraslawski, A.; Turunen, I. Synthesis of Heat-Integrated Thermally Coupled Distillation Systems for Multicomponent Separations. *Ind. Eng. Chem. Res.* **2003**, 42, 4329.
- (12) Rong, B. G.; Kraslawski, A. Partially Thermally Coupled Distillation Systems for Multicomponent Separations. *AIChE J.* **2003**, 49, 1340.
- (13) Emtir, M.; Rev, E.; Fonyo Z. Rigorous Simulation of Energy Integrated and Thermally Coupled Distillation Schemes for Ternary Mixture. *App. Thermal Eng.* **2001**, 21, 1299.
- (14) Wolff, E. A.; Skogestad, S. Operation of Integrated Three-Product (Petlyuk) Distillation Columns. *Ind. Eng. Chem. Res.* **1995**, 34, 2094.
- (15) Triantafyllou, C.; Smith, R. The Design and Optimisation of Fully Thermally Coupled Distillation Columns. *Trans. IChemE.* **1992**, 70, 118.
- (16) Halvorsen, I. J.; Skogestad, S. Shortcut analysis of Optimal Operation of Petlyuk distillation. *Ind. Eng. Chem. Res.* **2004**, 43, 3994.
- (17) Finn, A. J. Consider Thermally Coupled Distillation. *Chem. Eng. Prog.* **1993**, 89, 41.
- (18) Wright, R. O. Fractionation Apparatus. **1949** US patent No. 2471134.
- (19) Kim, Y. H. Structural Design and Operation of a Fully Thermally Coupled Distillation Column. *Chem. Eng. J.*, **2002**, 85, 289.
- (20) Halvorsen, I. J.; Skogestad, S. Minimum Energy Consumption in Multicomponent Distillation. 3. More than Three Products and Generalized Petlyuk Arrangements. *Ind. Eng. Chem. Res.* **2003**, 42, 616.
- (21) Rong, B. G.; Turunen I. A New Method for Synthesis of Thermodynamically Equivalent Structures for Petlyuk Arrangements. *Chem. Eng. Res. Des.* **2006**, 84, 1095.

- (22) Agrawal, R.; Fidkowski, Z. T. Are Thermally Coupled Distillation Columns Always Thermodynamically More Efficient for Ternary Distillations? *Ind. Eng. Chem. Res.* **1998**, 37, 3444.
- (23) Agrawal, R.; Fidkowski, Z. T. More Operable Arrangements of Fully Thermally Coupled Distillation Columns. *AIChE J.* **1998**, 44, 2565.
- (24) Kolbe, B.; Wenzel, S. Novel Distillation Concepts Using One-shell Columns. *Chem. Eng. Proc.* **2004**, 43, 339.
- (25) Parkinson, G. Chementator. **1998**, July, 21 and 22.
- (26) Lestak, F.; Egenes, D. J.; Reay, D. Efficiency at Low Cost. *AIChE Spring Meeting*, Howston Texas, **1999**; Paper 3c.
- (27) Schultz, M. A.; Stewart, D. G.; Harris, J. M.; Rosenblum, S. P.; Shakur, M. S.; O'Brien, D. E. Reduce Costs with Dividing-Wall Columns. *Chem. Eng. Prog. Mag.* **2002**, May, 64.
- (28) Niggemann, S.; Gruetzmann, S.; Fieg, G. Distillation Startup of Fully Thermally Coupled Distillation Columns: Theoretical Examinations. *8th Distillation & Absorption Conference*, London, UK, 4-6 September **2006**, Paper 78.
- (29) Martin, G. R. Keeping Down the Cost of the Revamp Investments. *Petr. Tech, Quat.* **1999**, Summer Issue, 99.
- (30) Gundersen, T. Retrofit Design Research and Applications of Systematic Methods. *Foundations of Computer-Aided Process Design*, **1990**, 213.
- (31) Thompson, R. W.; King, C. J. Systematic Synthesis of Separation Schemes. *AIChE J.* **1972**, 18, 941.
- (32) Mascia, M.; Ferrara, F.; Vacca, A.; Tola, G.; Errico, M. Design of Heat Integrated Distillation System for a Light Ends Separation Plant. *App. Thermal Eng.* **2007**, 27, 1205.
- (33) Hohmann, E. C.; Sander, M. T.; Dunford, H. A New Approach to the Synthesis of Multicomponent Separation Schemes. *Chem. Eng. Comm.* **1982**, 17, 273.
- (34) Rong, B. G.; Kraslawski, A.; Turunen, I. Synthesis and Optimal Design of Thermodynamically Equivalent Thermally Coupled Distillation Systems. *Ind. Eng. Chem. Res.* **2004**, 43, 5904.
- (35) Calzon-McConville C. J.; Rosales-Zamora, M. B.; Segovia-Hernandez, J. G.; Hernandez, S.; Rico-Ramirez, V. Design and Optimization of Thermally Coupled Distillation Schemes for the Separation of Multicomponent Mixtures. *Ind. Eng. Chem. Res.* **2006**, 45, 724.
- (36) Flores, O. A.; Cardenas, J. C.; Hernandez, S.; Rico-Ramirez, V. Thermodynamic Analysis of Thermally Coupled Distillation Sequences. *Ind. Eng. Chem. Res.* **2003**, 42, 5940.
- (37) Kakac, S.; Liu, H. Heat Exchanger selection, Rating and Thermal Design 2nd ed.; CRC press LLC, **2002**.

- (38) Douglas, J. M. *Conceptual Design of Chemical Processes*; McGraw Hill: USA, **1988**.
- (39) *Chemical Engineering*, January **2007**, 114, 68.
- (40) Rev, E.; Emtir, M.; Szitkai, Z.; Mizsey, P.; Fonyo, Z. Energy Savings of Integrated and Coupled Distillation Systems. *Comp. Chem. Eng.* **2001**, 25, 119.
- (41) Rong, B. G.; Fang-Yu, H.; Kraslawski, A.; Nystrom, L. Study on the Methodology for Retrofitting Chemical Processes. *Chem. Eng. Technol.* **2000**, 23, 479.
- (42) Fair, J. R. How to Predict Sieve Tray Entrainment and Flooding. *Petro/Chem. Eng.* **1961**, 33,45.

Part II
Process Design

Chapter 5

Heuristic Rules in Distillation Sequence Design

In this Chapter the heuristic rules for synthesis of distillation column sequences are presented considering some modification proposed in the literature during the years. The application to a four component mixture is considered together with a critical analysis on their validity and a comparison with rigorous simulations. The usefulness of the heuristic rules is particularly evident in cases when performing a detailed analysis for all the possible separation sequence options should be too much time consuming.

5.1 Introduction

As mentioned in the previous chapter, the definition of the best separation sequence for a multicomponent feed is a topic of continuous interest. The column sequencing is a crucial step in the flowsheet definition and its importance is related to the whole economic of the operation. Different separation tasks can be very different regarding the required energy and capital costs, thus a preliminary analysis of the most promising structures is absolutely recommended. It is well known that once the components of the feed mixture are selected, their concentration influences the choice of the best separation sequence.

This parameter together with the relative volatility, is one of the main tools used to define heuristic rules devoted to obtain a reduced space of research for the best separation sequence. These rules are applied to the space of simple column sequences where the number of configuration is related to the components number by the Thompson and King formula already reported in the previous section and used to calculate the data of Table 5.1. The table shows as the possible number of sequences sharply increases as the number of feed components increase.

Number of components	Simple Column Sequences
3	2
4	5
5	14
6	42
7	132
8	429
9	2860

Table 5.1: Dependence of the number of possible simple column configurations by the feed component number.

5.2 Heuristic Rules During the Time

Heaven¹ in the 1969 was one of the first that published a work introducing four general heuristic rules reported as follow:

1. *Separations where the relative volatility of the key components is close to unity should be performed in the absence of non key components.* In other

words, this means that the most difficult separations should be reserved until last in a sequence.

2. *Sequences which remove the components one by one in column overhead should be favoured.* This means to favourite the direct column sequence where the components are separate in order of decreasing volatility one by one as overhead products.
3. *Sequence which gives a more nearly equimolar division of the feed between the distillate and the bottom product should be favoured.* The reason is to perform a separation with similar reflux ratio in the stripping and rectifying sections, thus the operation becomes more reversible from a thermodynamic point of view.
4. *Separations involving very high specified recovery fractions should be reserved until last in a sequence.* In this way the separation is performed in absence of non-key components with the advantage to operate with smaller apparatus.

During the years the heuristic rules were deeply studied, criticized, and increased in their number. In 1977 Seader and Westerberg² utilize the experience of other authors to collect the following list of revised heuristic rules. They include conditions for a generic separation method together with indications about the technical feasibility of ordinary distillation:

- 1a. For each separation it is necessary to make a first screening of the different separation methods available and to choose the best one utilizing various factors. For example by selecting a parameter like the operative pressure it is possible to consider alternative separation methods to the distillation in the case that a refrigerant fluid is necessary as cooling agent in the condenser. Always considering the operative pressure, if it is necessary a vacuum operation, the possibility of a liquid-liquid extraction should be considered. In general, by introducing a separation index like the relative volatility between key components if this index is less than approximately 1.05 ordinary distillation is not economically feasible.
- 2a. For the selected methods develop an ordered list of the feed components according to the volatility value (or another separation index). In the case of widely variation between these values, it is recommended to perform the separation following the decreasing data trend. This rule is similar to heuristic 1. proposed by Heaven that dictates to perform last the most difficult separation.

- 3a. In the case of large variation in the feed composition but not in the relative volatility, it should be better to separate the components in the order of decreasing molar fraction.
- 4a. In the case when the molar fraction and the relative volatility not vary so much, the sequence that removes the components one by one as distillate should be preferred. This structure is called direct sequence.
- 5a. In the case that a mass separation agent is employed, it should be better to remove it in a separator following the column into which it is introduced.
- 6a. In the case of multicomponent products, sequences that produce those products directly or with a minimum of blending should be favourite.

The collection of rules presented give a high importance to the relative volatility, especially rules 2a, 3a and 4a, and the authors consider this value together with the feed composition. In particular, rule 4a better explains, compared to heuristic 2. of Heaven, in which cases the direct sequence should be utilized. Instead, rule 5a gives indications about the unit operations that do not utilize the heat as separating agent. Seader and Westerberg² used this list in the stated order to generate an initial flowsheet; anyway the proposed order is itself a heuristic.

In 1981 Nath and Motard³ defined a set of eight rules as an input to select a family of initial structures to apply alternative optimization methods. The contribution of these authors is that the previous heuristics are quantified with simple parameters. Referring only to the rules related to distillation sequences, they considered the following set:

- 1b. The easiest separation should be done first. The easiness of the separation is defined, in a qualitative way, as a separation that satisfy one of the following heuristic:
 - high value of the relative volatility
 - a separation that takes place in a balanced column
 - a separation with the smallest number of non-key components
 - a separation with the smallest amount of distillate.

In some cases these rules can be contradictory and for this reason they introduced a parameter to quantify the weight of each factor. The quantitative factor was called Coefficient of Difficulty of Separation (CDS) and is defined as follow:

$$CDS = \frac{\log \frac{sp_{LK}}{1-sp_{LK}} * \frac{sp_{HK}}{1-sp_{HK}}}{\log \alpha_{LK/HK}} * \frac{V}{V+L} * \left(1 + \left| \frac{V-L}{V+L} \right| \right) \quad (5.1)$$

The first part of eq. 5.1 is related to the minimum number of theoretical stages and regards the heuristic rule that recommends to favourite the separations with a high value of relative volatility or separations performed in absence of non-key components. The second term takes into account the rule to minimize the distillate production. The last term is a penalty for non balanced columns. In the case of $V=L$ the column is balanced and the penalty term is equal to one. The split with the smallest value of CDS should be tried for detailed simulations.

Other heuristics proposed from Nath and Motard provided indications about the operating conditions of the units like the operative pressure, the reflux ratio range variation or the recoveries of each key component.

The novelty of these heuristic rules is the attempt to quantify rules previously reported only in a qualitative way. Following the heuristic 1.b it is possible to order the separations according to the increasing value of the CDS.

Another work to be considered is from Nadgir and Liu⁴ that in 1983 made a broadly classification of heuristic rules in four categories:

- Method heuristics (M)
- Design heuristic (D)
- Species heuristics (S)
- Composition heuristics (C)

The method heuristics include the rules regarding the separation method that should be used for a given problem specification.

The design rules help the designer in the choice of the optimal sequence utilizing separation parameters.

Species heuristics are based on the difference in properties of the feed compounds:

S1: Remove first most hazardous or corrosive compounds.

S2: Perform the most difficult separation last in the column sequence.

Composition heuristics are based on the effect of feed composition in the separation cost:

C1: remove the most plentiful component first if the separation factor or the relative volatility justifies this separation.

C2: consider preferentially sequences with an equimolar distribution between stripping and rectifying column section. In cases when it is difficult to identify which split is about of 50/50, it is possible to utilize the Coefficient of Easy of Separation (CES) defined as:

$$CES = f * \Delta \quad (5.2)$$

Where f is the ratio between the molar flow rate of the column products (B/D or D/B). The smallest or the nearest to the unity value is chosen. Δ can be defined as the difference between the normal boiling point of the components to be separated or it can be calculated by the following equation:

$$\Delta = (\alpha - 1) * 100 \quad (5.3)$$

From this summing up it is clear that the definition of a reliable set of heuristic rules was a research topic of high interest. It is also evident that is impossible to define general rules applicable for every separation case. Heuristic rules often contrast each others and their application can lead to non optimal configurations as already pointed out by some authors.⁵

In this work a list of heuristics that summarize the different sets proposed during the years is considered for the application to a four component mixture and five different composition cases. It must be pointed out that the extraction of some heuristic rules and their order application represents an heuristic itself.

The criteria are formulated as follow:

- In the case of wide variation, perform the separation in decreasing order of relative volatility.
- If the components in the feed have a large variation in the molar fraction, but not in the relative volatility, perform the separation in the order of decreasing molar fraction.
- If there is not a big variation in both relative volatility and molar fraction it should be better to favourite the direct sequence.
- Favourite the balanced columns between distillate and bottoms flow rate. If it is difficult evaluate the preferred splits for a 50/50 separation, evaluate the CES and perform the separation in decreasing order of this value.

The designer is free to violate this rules under specific situations or when particular substances force in the utilization of one particular method or sequence of separation.

5.3 The Case Study

1000 kmoli/h of a four components mixture of n-butane, n-pentane, n-hexane and n-heptane is considered. Five different composition cases, summarized in Table 5.2,

are compared in order to verify the reliability of the heuristic rules previously presented.

	Case 1	Case 2	Case 3	Case 4	Case 5
Component	Molar Fraction				
n-C₄H₁₀	0.70	0.10	0.25	0.10	0.40
n-C₅H₁₂	0.10	0.10	0.25	0.40	0.10
n-C₆H₁₄	0.10	0.10	0.25	0.40	0.10
n-C₇H₁₆	0.10	0.70	0.25	0.10	0.40

Table 5.2: Feed case compositions.

For each composition case, the five different simple column configurations reported in the Appendix B Fig. B1, are feasible.

The feed was assumed at the boiling point at atmospheric pressure. The application of the heuristic rules does not require more information and in the following paragraphs the best sequence for each composition case indicated from the heuristics is reported.

The components are called with letter A, B, C and D from the lightest to the heaviest.

The relative volatility was obtained as the geometric average of the volatility at the overhead and bottom temperatures obtained from the equilibrium calculations considering ideal behaviour in both liquid and vapour phases:

$$y_i P = x_i P_{si} \quad (5.4)$$

The pressure of the system was chosen to allow the use of water as the cooling agent in the overhead condenser. Considering the availability of water at 20°C from the water supply and a difference of temperature of 20°C from the inlet and the outlet of the condenser, a minimum temperature difference of 10°C between auxiliary and process fluid was assumed.

The vapour pressure of the compounds was estimated using simplified correlations from the Reid, Prausnitz and Poling book.⁶

5.3.1 Composition Case 1

As reported in Table 5.2 the feed contains the lightest component in large excess compared to the other ones. The feed boiling point at 1 atm is equal to 281.7 K. At this temperature the relative volatilities, referred to the adjacent heavier component, are:

$$\alpha_{A/B} = 3.98$$

$$\alpha_{B/C} = 3.78$$

$$\alpha_{C/D} = 3.73$$

To choose the best separation sequence, we consider that a large excess of the lightest component together with a small variation in the relative volatilities values are present, thus by applying the corresponding heuristic rule the best simple sequence should be the direct one or any structure in which the component A is removed first.

To complete the separation sequence for the other components, the CES value can be used for the mixture BCD.

	B/CD	BC/D
f	0.1/0.2	0.1/0.2
Δ	165	153
CES	82.5	76.5

Table 5.3: CES calculation for composition case 1.

By ordering the separation sequence according to the decreasing values of CES the select sequence is the direct one:

A/BCD; B/CD; C/D

5.3.2 Composition Case 2

In this case the component in excess is the heaviest one. The boiling point temperature of the feed is 331.5 K and the relative volatilities of the components are:

$$\alpha_{A/B} = 3.01$$

$$\alpha_{B/C} = 2.83$$

$$\alpha_{C/D} = 2.75$$

There are too low differences in the relative volatility values to justify the choice to perform the component separation following the decreasing order of the relative volatilities. It is possible to apply the heuristic rule to remove first the most plentiful compound. In this case the indirect sequence or configurations derived from this one

should be favourite. If the first column in the sequence removes the component D, the order of separation of the other components must be defined. The CES can be used to this scope:

	A/BC	AB/C
f	0.1/0.2	0.1/0.2
Δ	169	159
CES	84.5	79.5

Table 5.4: CES calculation for composition case 2.

Utilizing the previous heuristic rule and the CES, the selected configuration is the indirect-direct:

ABC/D; A/BC; B/C

5.3.3 Composition Case 3

An equimolar feed composition is considered, the feed boiling point is 304.9 K and the relative volatilities are the following:

$$\alpha_{A/B} = 3.44$$

$$\alpha_{B/C} = 3.25$$

$$\alpha_{C/D} = 3.18$$

In this case there is not a significant variation in the volatility values and also in the feed compositions, so according to the heuristics it is possible to favourite the direct sequence. It is also evident that it is possible to perform the separation in a balanced column using a symmetrical configuration. The selected configurations can be indicated as:

A/BCD; B/CD; C/D

AB/CD; A/B; C/D

5.3.4 Composition Case 4

This feed composition case contains an equal excess of the two medium components B and C. The feed boiling point temperature is 314.9 K and the corresponding relative volatilities are:

$$\alpha_{A/B} = 3.26$$

$$\alpha_{B/C} = 3.07$$

$$\alpha_{C/D} = 3.00$$

There is no variation in the volatility or in the composition that justifies following the heuristic that stated to perform the separation of the most plentiful component first, so it is possible to prefer the direct sequence. Another possibility is the choice to realize a balanced split in at least one column of the distillation sequence using the symmetrical configuration.

The selected configurations are:

A/BCD; B/CD; C/D

AB/CD; A/B; C/D

5.3.5 Composition Case 5

In this composition case there is an excess of the lightest and the heaviest component and the feed boiling point is 297.0 K

$$\alpha_{A/B} = 3.60$$

$$\alpha_{B/C} = 3.41$$

$$\alpha_{C/D} = 3.34$$

Since there is a low variation in the volatility values and there is an equal quantity of the most plentiful components we can choose to favourite the direct sequence or to remove the components following the decreasing molar composition values. If also the possibility to perform the separation in a balanced column is taken into account all the possible five simple column configurations can be selected. To shrink the exploration space it is possible to consider at the same time the heuristic to prefer the direct sequence with the indication to remove the most plentiful component first. In this case the direct-indirect sequences must be selected.

Summarizing the selected sequences are:

A/BCD; BC/D; B/C

AB/CD; A/B; C/D

5.4 Rigorous Calculations

To verify the reliability of the heuristic rules, a rigorous simulation for all the different composition cases reported in Table 5.2 were performed to obtain the data for the economic evaluation of each simple column sequence. All the parameters used are obtained from the Underwood-Winn-Gilliland method already implemented in the simulation package Aspen Plus. A reflux ratio of 1.1 times the minimum value was considered for each column and a molar purity of 99% was fixed for each product stream. The design and operational parameters are used as input values for

the rigorous simulations performed with the RADFRAC model and optimized for the required purity. The data obtained like column diameter, condenser and reboiler duty, number of stages are used for the operational and capital cost evaluation following the procedure reported in the Appendix A. For each composition case the results are commented and compared with those obtained from the application of the heuristic rules.

5.4.1 Case 1

Following the procedure described, the TAC calculations give the results reported in Figure 5.1.

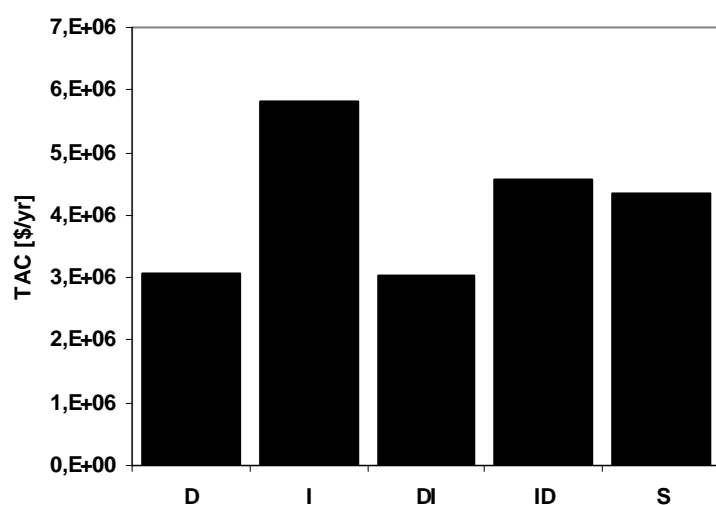

Figure 5.1: TAC values for composition case 1.

It is possible to notice that the best sequences are the direct and the direct-indirect ones. The difference between the two values is too small to make a choice between these two sequences. From the application of the heuristic rules, the direct sequence was selected and the TAC calculations confirm that this sequence is the best.

5.4.2 Case 2

In this case a feed mixture with an excess of the heaviest component was considered. The results of the TAC calculations for all the possible simple column sequences are reported in the following Figure 5.2.

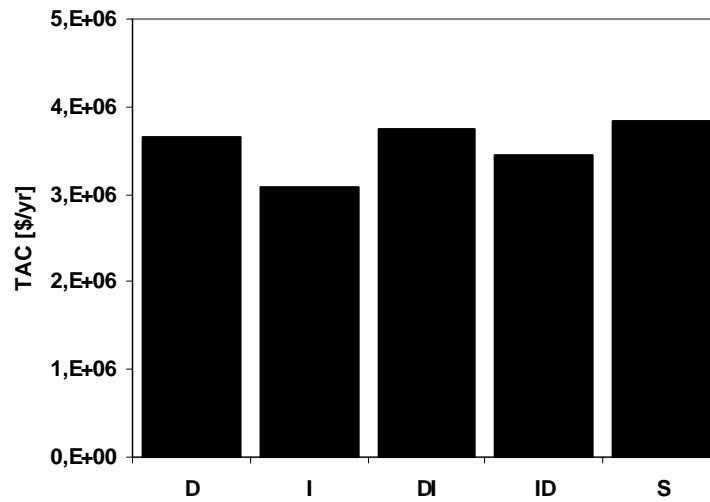

Figure 5.2: TAC values for composition case 2.

The result from the heuristic rules and the TAC values agree that the best sequence is the indirect one.

5.4.3 Case 3

For the equimolar composition of feed reported as case 3, the results are presented in Figure 5.3:

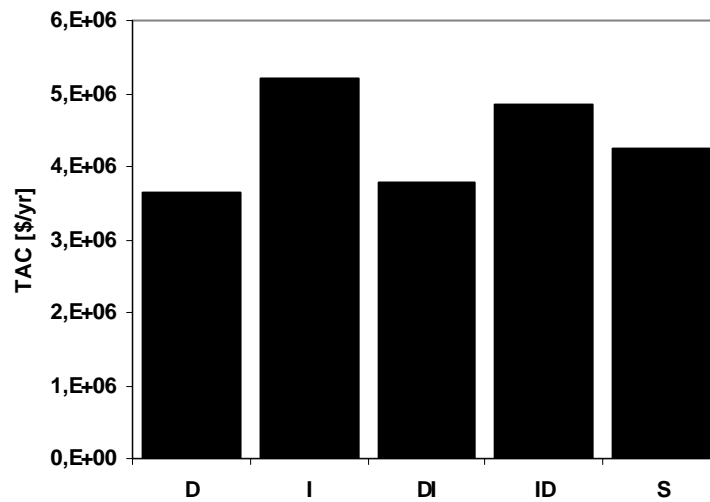

Figure 5.3: TAC values for case composition 3.

The best sequence from the TAC calculations is the direct one followed by the direct-indirect and by the symmetrical. From the application of heuristic rules the direct and the symmetric ones were selected. It is possible to state that in general there is an agreement between the two methodologies, but in the case of perfect balanced feed composition only the consideration about the compounds distribution is not enough to select the best sequence. It is possible that the benefit to operate with a balanced column is overcome by a more convenient separation sequence following the relative volatility order.

5.4.4 Case 4

In this case the two middle components are in equal excess compared to the lightest and heaviest components. The selected configurations from the heuristic rules application were the direct and the symmetrical ones. The Figure 5.4 reports the TAC calculations, that confirm this result with a very low difference between the two configurations, so both sequences should be selected as optimal at this stage of analysis.

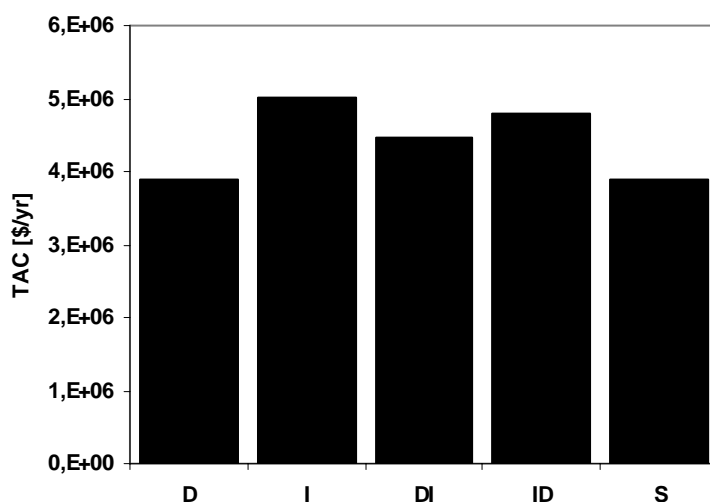

Figure 5.4: TAC values for case composition 4.

5.5.5 Case 5

This is a case with an excess of the lightest and the heaviest components. The heuristic rules application indicates the direct-indirect and the symmetrical sequences as the best separation ones.

The results of the TAC calculations are reported in the following Figure 5.5.

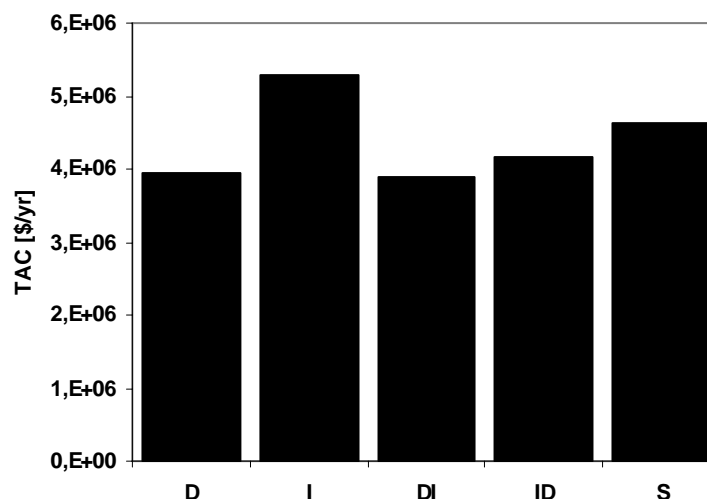

Figure 5.5: TAC values for case composition 5.

The best configurations are the direct and the direct-indirect ones with quite low difference in the TAC values. Anyway the symmetrical sequence initially selected is not a good option for the considered feed composition case.

5.5. Summary

From the comparison between the application of the heuristic rules and the rigorous calculations, some observation can be done. For the cases 1 and 2 were respectively the lightest and the heaviest components are in large excess compared to the other ones, the heuristic rules and the TAC calculation give the same results. It is possible to note that, whereas for the case 1 there is a pronounced difference in the TAC value between the different configurations, not a similar result was observed for the feed composition case 2. This fact is evident by considering the difference between the TAC value corresponding to the direct and the indirect sequences. This observation was already reported by Malone et al.⁵ analyzing a three components mixture. The convenience to remove the most plentiful component first is always true for the lightest component but *“the opposite case is not always true”*. One reason can be searched in the distribution of the columns' pressure in the sequences to satisfy the limitation in the use of water in the overhead condenser. In fact, in the indirect column sequence, a high pressure in each column must be adopted for the presence of the lightest components, unlike the direct configuration where the compounds are removed from the lightest to the heaviest. Of course to perform the

separation at a low pressure allows to reduce the separation costs. It is possible to conclude that in the cases where the heaviest component is the plentiful one there is the convenience to use the indirect sequence or sequences that remove this component first, only in the case when there is a high difference in the feed quantity between the heavy component and the other ones. Otherwise the effect of the pressure can be dominant in the evaluation of the total separation cost and other configurations can be more convenient. Considering to this regard the case 5, where the lightest and heaviest components are present in equal amount, there is a broad difference between the TAC values associated to the direct and the indirect sequences, with a clear advantage in employing the direct one. Considering these results it is possible to assert that in the separation cases when one component is in excess, it should be better to perform the separation removing the plentiful component first; anyway if a so evident excess is not observed or an equal amount of lightest and heaviest components is present, the direct separation sequence should be preferred. For composition cases 3, 4 and 5 there is the possibility to perform at least one separation in a perfect balanced column. In these cases the corresponding CES is the highest possible value because the f factor is one. The selected separation sequence obtained using this criterion is the symmetrical one. Anyway from the TAC calculations the symmetrical sequence is not the most convenient for cases 3 and 5 and only for case 4 it can be considered optimal together with the direct one. Also in this case the limitations in choosing to operate with a balanced column can be found in the work of Malone et al.⁵ Thus the CES index is not completely suitable for balanced composition feeds because the feed component distribution has a too high weight compared to the influence of the relative volatility. Moreover other parameters should be included in the index, as for example the pressure difference of the columns to satisfy the design limitations in the condensing system. Considering to this purpose the composition case 3, the direct sequence that is the best one has a pressure column distribution of 480, 160, 110 kPa while the symmetrical one has values of 310, 480, 110 kPa. The third column, where the split C/D is performed, is equal in the two separation sequences, while the advantage to operate with balanced columns is reduced in the symmetrical sequence by the necessity to have a higher pressure in the column that performs the AB/CD separation. Thus, a more valuable steam is required in the reboiler. It is possible to correct the CES index using a better estimation of the relative volatilities by using a mean temperature of the column for each separation sequence instead of the feed temperature and a fixed pressure. Anyway it is not useful to introduce additional calculations to a method that must just give a first indication on the best separation sequence.

Using the information derived from the heuristic rules, some authors tried to develop analytical equations, called quantitative heuristics, to make easier the choice of a set of potential optimal sequences. The scope is to develop a suitable analytical formula as simple as possible and easy to manage from a mathematical point of view. One of the first attempts was made from Rudd et al.⁷ that defined a correlation for the distillation cost:

$$\text{Distillation Cost} \approx \frac{\text{Feed Rate}}{\text{Boiling Point Difference}} \quad (5.5)$$

Also the CES previously introduced can be considered as an index that attempt to quantify some of the most common heuristic rules.

Successively Rod and Marek⁸ developed an equation valid for ternary mixtures, but applicable also to multicomponent mixtures if considered as pseudo-ternary ones. Malone et al.⁵ develop a better cost model for the separation system using an estimation of the overhead vapour flow rate that can be considered proportional to the separation cost.

The assumption to consider the distillation separation cost proportional to the overhead flow rate is a well known procedure. In fact for small values of the relative volatility the Taylor series expansion gives:

$$\ln \alpha = \alpha - 1 \quad (5.6)$$

and considering the equation of Clausius Clapeyron:

$$\ln \alpha = \ln \frac{P_{SA}}{P_{SB}} = \ln \exp \left\{ -\frac{\Delta H_v}{R_g} \left(\frac{1}{T_A} - \frac{1}{T_B} \right) \right\} = C_0 (T_A - T_B) \quad (5.7)$$

α can be related to the boiling point difference of the compounds.

Using these results it appears justified the assumption to consider the difference in the boiling points or the term $(\alpha-1)$ in the CES index.

The “*Distillation Cost*” previously defined can be written as:

$$\text{Distillation Cost} \approx \frac{F}{\Delta T} \approx \frac{F}{\ln \alpha} \approx \frac{F}{\alpha - 1} \quad (5.9)$$

and considering a binary mixture and a saturated liquid feed, it is possible to utilize the approximate relation:

$$V = (R + 1)D = \left(\frac{1.2x_D}{(\alpha - 1)x_F} + 1 \right) \frac{Fx_F}{x_D} = \left(\frac{1.2}{\alpha - 1} + \frac{x_F}{x_D} \right) F \quad (5.10)$$

From eq. 5.10 it is possible to see that the index of Rudd et al. is proportional to the vapour flow rate.

Anyway these methods become more complex if applied to systems with more than three components and rules to define pseudo-ternary mixtures are necessary in this case.

Later, Porter and Momoh⁹ proposed the ROTE equation assuming a constant ratio between the energy cost and the capital cost and considering energy cost proportional to the overhead vapour load.

The resulting equation valid for sharp separation between the components, is:

$$ROTE = D + \frac{E/E_{\min}}{\alpha_{LK, HK} - 1} F \quad (5.11)$$

The correlation was proved to be a valid substitute of heuristic rules for volatilities higher than 1.1. Anyway, as pointed out by Jobson¹⁰ this index does not reflect the cost implications of different product specifications and does not include capital costs that for some configurations can be relevant. For this reason Jobson proposed the “boiling capacity variable”,¹¹ and its extension to a distillation column sequence, as a more complete index that respects, in a more suitable way, the TAC variation between the different possible simple configurations. The resulting correlation is the following:

$$(k_{ov} - k_{feed})F = \sum_{Columns} [V_i(N_i + 1) + D_i] \quad (5.12)$$

where the number of stages can be evaluated with a short-cut method.

Nowadays the availability of reliable and fast process simulation packages makes the screening process easy, but due to the increasing number of feed components the use of rigorous methodologies is computationally demanding and absolutely inappropriate for initial flowsheet synthesis. Thus both heuristic rules and other indices are still useful tools to reduce the searching space. It is undisputed that the knowledge of these rules helps the designer to select an initial family of configurations and to have a general idea of the attended results. In any case it is also evident that the nature of the method makes not convenient to select only one configuration as the best one.

5.6 Notation

α = relative volatility
B = bottom molar flow rate
D = distillate molar flow rate
E = reflux ratio
 ΔH_v = vaporization heat
 ΔT = boiling point difference
F = feed flow rate
k = boiling capacity variable
N = number of stage
 P_s = vapour pressure
 R_g = ideal gas constant
sp = split fraction
V = vapour flow rate
L = liquid flow rate
y = vapour molar fraction
x = liquid molar fraction
P = pressure of the system
 P_s = vapour pressure
T = temperature

5.6.1 Subscripts

A = generic specie
B = generic specie
LK = light key component
HK = heavy key component
min = minimum value
ov = overall
F = feed
D = distillate

5.7 References

- (1) Heaven, D. L. M.S. Thesis in chemical engineering, University of California, Berkeley, **1969**.
- (2) Seader J. D., Westerberg, A. W. A Combined Heuristic and Evolutionary Strategy for Synthesis of Simple Separation Sequences. *AIChE J.* **1977**, 23(6), 951.
- (3) Nath R., Motard R. L. Evolutionary Synthesis of Separation Processes. *AIChE J.* **1981**, 27(4), 578.
- (4) Nadgir, V. M., Liu, Y. A. Studies in Chemical Process Design and Synthesis: Part V: A Simple Heuristic Method for Systematic Synthesis of Initial Sequences for Multicomponent Separations. *AIChE J.* **1983**, 29(6), 926.
- (5) Malone, M. F., Glinos, K., Marquez, F. E., Douglas, J. M. Simple, Analytical Criteria for the Sequencing of Distillation Columns. *AIChE J.* **1985**, 31 (4), 683.
- (6) Reid, R. C., Prausnitz, J. M., Poling, B. E. The Properties of Gases and Liquids Fourth Edition, McGraw-Hill, **1988**.
- (7) Rudd, D. F., Powers, G. J., Siirola, J. J. Process Synthesis, 37, Prentice-Hall, Englewood Cliffs, NJ, **1973**.
- (8) Rod, V., Marek, J. Separation Sequences in Multicomponent Rectification. *Coll. Czech. Chem. Commun.* **1959**, 24, 3240.
- (9) Porter, K. E., Momoh, S. O. Finding the Optimum Sequence of Distillation Columns – an Equation to Replace the “Rules of Thumb” (Heuristic). *Chem. Eng. J.*, **1991**, 46, 97.
- (10) Jobson, M., Hildebrandt, D., Glasser, D. Variables Indicating the Cost of Vapour-Liquid Equilibrium Separation Processes. *Chem. Eng. Science* **1996**, 51(21), 4749.
- (11) Jobson, M. Short-Cut Evaluation of Distillation Sequences. *Computers Chem. Engng.* **1997**, 21, s553.

Chapter 6

The Divided Wall Column

It is known that utilizing only simple columns for the separation of a n -components mixture at least $(n-1)$ columns are necessary. Thus, in a four component separation three columns are needed to obtain the pure compounds.

The substitution of two simple columns with a divided wall column (DWC) that performs a three components separation through a vertical partition in the shell is considered in this chapter. The DWC offers an alternative to conventional distillation towers with possible savings in both energy and capital costs. The insertion of a DWC is considered in the best simple column sequence selected in the preceding chapter for the separation of a four component mixture with different composition cases.

The resulting separation sequence can be considered as an hybrid configuration made from a simple column followed or preceded by a divided wall column.

6.1 Introduction

The bottom line of all the work done in this thesis is the necessity to improve the energy efficiency of distillation systems. This necessity is influenced by the tight environmental regulations, the growing of competition, so as the high energy costs. In the first part of the thesis, distillation sequences with thermal coupling were presented as a way to perform a separation with less energy consumptions compared to the traditional simple column sequencing. A particular type of column that realizes energy and capital cost savings is the Petlyuk column or its derived structure called Divided Wall Column (DWC). This type of configuration was discovered and patented by Wright in 1949¹ but only in the last years has become more attractive and its applicability more realistic.² The principal limitation in employing this structure was the lack in the design, and the difficulty in the controllability of the system; anyway with modern control techniques, more suitable mathematical knowledge, high modelling tools and dynamic simulations, the problem can be easily overcome.^{3,4} This distillation configuration was initially proposed for a three components separation and recently extended also to a higher number of components in the mixture.^{5,6} However the controllability of the system was proved only for three component separation and up to date no serious attempts have been made to implement such more complex systems. Thus, in the present work only a DWC for a three component separation is considered. In particular to apply the DWC structure to the case study analyzed in the previous chapter the sequence is considered as an hybrid structure made from a simple column followed or preceded by a DWC.

To this scope it is useful a description of the behaviour of this distillation column and of the mathematical principles used to model the system.

6.2 The Divided Wall Column Principles

The main feature at the base of the development of the DWC is the aim to reduce the thermodynamic losses due to the remixing of the middle components. As mentioned in the Chapter 4, examining the composition profile of a middle boiling component through a simple column reported in Fig. 4.1 it appears that, its concentration increases causing a peak with a subsequent decrease as the concentration of the less volatile component increases. In other words a high concentration of the middle boiling component is first reached and then lost. This phenomenon known as remixing is inevitable in single column sequences with a multicomponent feed. The other loss previously mentioned is the feed mismatch due to a composition

difference between the feed and feed tray. Also in this case there is a degradation of the distillation purity that should be minimized. In the Petlyuk configuration reported in Figure 6.1a these losses are expected to be lower than in the traditional configurations. The Petlyuk configuration consists of two columns; the first one, called prefractionator, performs a preliminary non-sharp separation for the middle boiling component; in the second column the mixture of the lightest and the middle component is separated in the upper part of the column and the remaining component is separated in the bottom. The two columns are linked with interconnected liquid-vapour streams, or thermal coupling, and for this reason sometimes this configuration is referred as a fully thermally coupled column.⁷ The thermal integration improves the vapour/liquid interaction in the different column sections minimizing the separation losses. It has been proved that the Petlyuk configuration requires, compared to all the possible column configurations, the lowest total boil-up for a given separation of a three component ideal mixture.⁸ The total vapour flow reduction was quantified in the range of 10-50% compared to the direct and indirect configurations for the separation of a three component mixture.^{7,9} One of the main problems of this configuration is how to set the pressure between the prefractionator and the main column to obtain a natural flowing of the vapour stream from one column to another. In fact the vapour stream has to be transferred from the prefractionator to the top of the main column and from the bottom of the main column to the prefractionator. Considering this fact the bottom of the prefractionator has to be at a lower pressure than the bottom of the main column while the pressure in the top of the prefractionator has to be higher than the pressure of the top of the main column. This requires a carefully control of the pressure profile in the columns. For this reason alternative structures, named thermodynamically equivalent structures, are developed to overcome this limitation. One of these solutions is reported in Figure 6.1b.¹⁰ This configuration can operate without difficulties in controlling the vapour transfer between the columns. The differences with the Petlyuk structure are the different location of the reboiler and the condenser and the position of the product streams that are not in the same column, but the energy requirement is exactly the same.

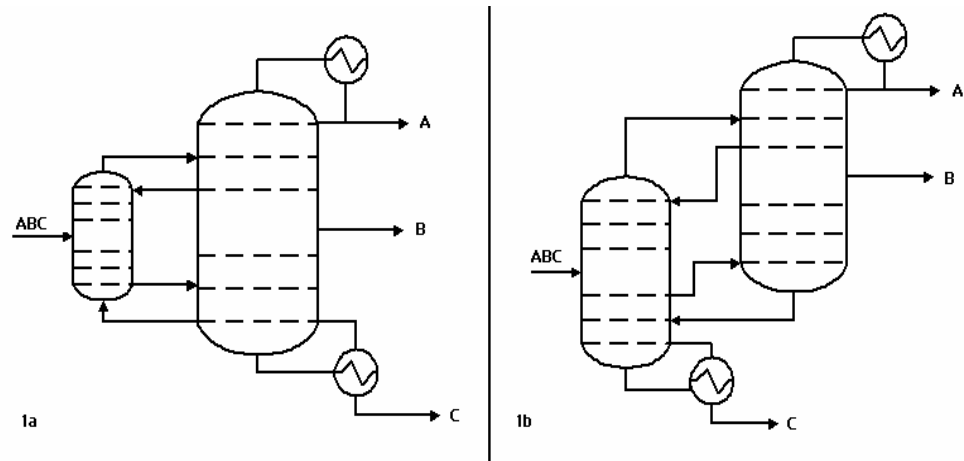

Figure 6.1: Petlyuk configuration (1a) and its thermodynamically equivalent structure (1b).

From the Petlyuk configuration it is possible to derive the DWC by including the prefractionator in the main column. The resulting configuration, reported in Figure 6.2, consists of a single shell column with a partitioning wall that separates the feed location from the withdrawn of the middle component. In this configuration there is a split of the vapour from the reboiler and of the liquid from the condenser on the two sides of the wall.

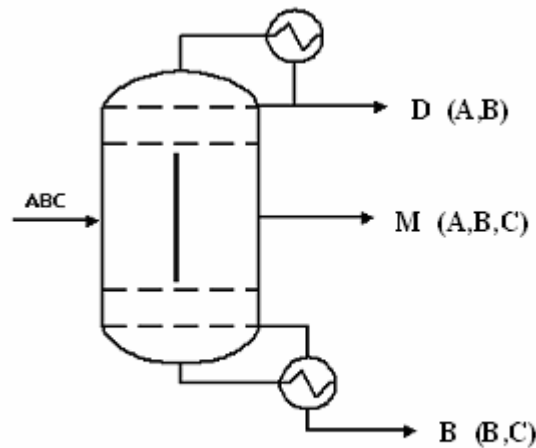

Figure 6.2: DWC configuration.

The Petlyuk and the DWC configurations can be considered equivalent structures assuming that no heat transfer across the wall occurs. In this case the two structures are thermally equivalent with the same energy consumption.¹¹ Rules of thumb suggest to set the partition in such a way that is in the middle third of the

equilibrium stages.¹² Usually the wall is located in the centre of the column to realize a symmetrical distribution of the liquid and the vapour. Off-centred positions were also considered at laboratory scale but not in the industrial practice due to cost, mechanical stability and easiness of fabrication reasons. An asymmetrical distribution of the vapour on one side of the wall can be realized adding additional pressure drop on one side, but this operation requires very accurate pressure drop correlations and for this reason the symmetrical split is normally preferred.¹³

The DWC configuration offers the advantage to increase the separation efficiency and at the same time to save capital costs for column shells, reboilers and condensers compared to the traditional simple column sequences.

Table 6.1 reports a basic comparison between conventional sequences and DWC.¹¹

	Conventional Column Sequence	DWC
Column Shells	2	1
Reboilers	2	1
Condensers	2	1
Capital Savings	---	15-30%
Remixing	Yes	No
Feed Mismatch	Yes	Reduced

Table 6.1: Conventional column and DWC comparison.

Obviously the DWC presents both benefits and drawbacks, that are summarized in the following.

The benefits are the already mentioned possibilities to reduce the total cost of the operation. The cost saving is related to the separation specification and to the feed component distributions. On this topic some guidelines are an useful tool to choose if this kind of configuration is suitable for the required separation. Usually the purity of the middle boiling component that can be reached with the DWC is higher than the simple column with a sidedraw, thus if high purity specifications are not required for this component a simple column can be enough for the separation. Anyway also in this case the DWC can be more convenient from the energetic point of view.

Another rule of thumb suggests that if the middle boiling component is in excess and if the lightest and the heaviest ones are in equal quantity, the DWC can be the more convenient structure. This rule could be integrated by considering also the difficulty of the separation by evaluating the relative volatility between the splits. If the split difficulty between the lightest and the middle components and between the middle and the heaviest ones are comparable, the DWC configuration can be convenient. The heuristics for the DWC are subject to exceptions like in the case of simple column sequence and their usefulness is only for screening purposes.¹⁴

Considering some potential disadvantages it is necessary to take into account that the presence of only one condenser and one reboiler requires a higher quality of the heat supply because the condenser operates at the coldest temperature required for the separation and the reboiler at the hottest one. On the other side it should be noted that the process stream is reboiled only once and the total residence time in the high temperature zone is minimized. Thus it is necessary to evaluate, in relation to the processed substance, if it is more convenient to operate with a short residence time at a high temperature or with a longer residence time at two different temperature levels.

The temperature levels in the column are related to the pressure that, in the case of a DWC replacing a conventional column sequence, is the highest one. If the simple column configuration works in a wide range of pressure to replace it with a DWC can be not cost-effective. Another problem is the possibility to obtain a taller and larger DWC compared to the simple columns performing the same separation task.

6.3 World Applications of DWCs

In 1985, BASF constructed and started up the first commercial DWC. BASF is also believed to be the leader in the total number of operating columns with roughly 25 DWCs working since now.¹²

Kellogg and Sumitomo Heavy Industries (Tokyo) start to commercialize DWC based on the Petlyuk revised configuration with a prefractionator and a main column for the separation of three component mixtures before the 1999.⁴ Sumitomo Heavy Industries uses an on site pilot plant and refers its technology as “*Column in Column*”.¹⁵

Kellogg Brown and Root has designed at least two DWCs for BP.¹⁴

It is well known that Sasol and Linde common project for the implementation of a DWC in the 1-octene production plant in South Africa¹³ realizes the world’s biggest DWC, 107 m tall and with a diameter of 5 m.

Krupp Uhde designed a DWC to remove benzene from pyrolysis gasoline for Veba Oil and a another one for Chevron.¹⁵

UOP designed two DWCs for the production of linear alkyl benzene.¹⁴

6.4 Modeling

Develop a design model to describe the steady state behaviour of a divided wall column is a difficult task. In the most used process simulation packages, like Aspen Plus, DWC systems are not available as a standard unit operation already implemented in the simulator libraries. Thus a DWC column must simulated as a

conventional distillation unit linked by thermal coupling¹² so as reported in Figure 6.1a. The usually design procedure followed for simple distillation systems utilizes a short cut model to initialize a more rigorous simulation. In the DWC case the procedure becomes more complex because short cut models are not available. During the years different research works focused their attention on the application of the Underwood method to side strippers, side enrichers and Petlyuk configurations.^{7,16,17} The configuration reported in Figure 6.3 was considered to obtain, from a short-cut model, the parameters necessary to initialize the rigorous simulation performed by means of Aspen Plus.

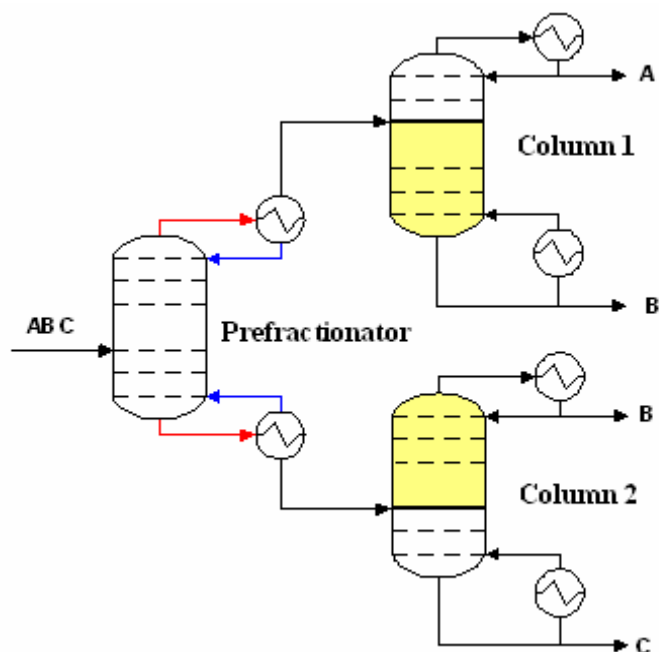

Figure 6.3: Distillation structure considered for the application of Underwood's method.

The first column is the prefractionator, equipped with a partial reboiler and a partial condenser; this column represents the portion of DWC situated between the feed and the vertical baffle. The overhead vapor stream (red marked) from the prefractionator is fed to the first column and the reflux (blue marked) becomes the liquid side stream going back to the prefractionator. In the same way the partial reboiler of the prefractionator is linked to the second column. The prefractionator is included in the single shell column configuration behind the liquid side stream of the first column and above the side stream of the second one (yellow zones in the figure). This area is the portion of column that includes the partition. Using the described representation

it is possible to apply the Underwood equations with just a few modifications. There are only two assumptions underlying Underwood's method;¹⁸ constant relative volatility and molar over flow, that are still considered in the extension of the method to complex configurations. In the following description of the method description, for each column a light key and an heavy key component is identified. All components lighter than the light key appear only in the distillate flow rate and the components heavier than the heavy key appear only in the bottom stream. If one or more components are present between the light and heavy key they are called middle key or distributed components. In this case the separations performed in the presence of middle key components are called non-sharp and the middle key/s is/are distributed between the distillate and the bottom streams. The short-cut method was implemented utilizing the Fortran code.

6.4.1 Application of the Fenske-Underwood-Gilliland method

The prefractionator can be considered as a simple column and the classic Underwood methodology can be applied.¹⁸

In the prefractionator the separation between the light and heavy key is performed and at least one component is distributed between the distillate and the bottom stream. The formulation of the Underwood equations is:

$$\sum_i \frac{\alpha_i \cdot f_i}{\alpha_i - \phi_j} = F \cdot (1 - q) \quad (6.1)$$

$$\sum_i \frac{\alpha_i \cdot d_{1i}}{\alpha_i - \phi_j} = D_1 \cdot (1 + R_{1m}) \quad (6.2)$$

$$\sum_i \frac{\alpha_i \cdot b_{1i}}{\alpha_i - \phi_j} = -S_{1m} \cdot B_1 \quad (6.3)$$

Sometimes these equations are considered in terms of split fractions, defined as the ratio of the component molar flow rates in the distillate and in the feed streams.

$$\xi_i = \frac{d_i}{f_i} \quad (6.4)$$

$$\sum_i \frac{\alpha_i \cdot \xi_i f_i}{\alpha_i - \phi_j} = D_1 \cdot (1 + R_{1m}) = V_{1m} \quad (6.5)$$

$$\sum_i \frac{\alpha_i \cdot (1 - \xi_i) f_i}{\alpha_i - \phi_j} = -S_{1m} B = -\bar{V}_{1m} \quad (6.6)$$

As said before, assuming that the components lighter than the light key are present only in the distillate flow rate, it is evident that the recovery of these components is equal to one, and the recovery of components heavier than the heavy key is equal to zero.

It should be noted that eqs. 6.2 and 6.3 (or eqs. 6.5 and 6.6) are related because the reflux and the reboiler ratio are not independent parameters but are linked by the feed quality parameter.

$$q = \frac{\bar{L} - L}{F} \quad (6.7)$$

$$1 - q = \frac{V - \bar{V}}{F} \quad (6.8)$$

$$V = D(R + 1) \quad (6.9)$$

$$\bar{V} = SB \quad (6.10)$$

Substituting eqs. 6.9 and 6.10 in 6.8, the relation between the top and the bottom refluxes can be obtained:

$$D(R + 1) = F(1 - q) + SB \quad (6.11)$$

Equation 6.1 is usually referred as the feed equation and can be solved independently from equations 6.2 and 6.3 to obtain the common roots of eqs. 6.2 and 6.3. These roots depend only from the feed composition and relative volatility and lie between the volatilities of the key components. Other values of ϕ satisfy eq. 6.1 but have no physical significance. A simple “*regula falsi*” method can be used to obtain the searched root values.

In the case of a number m of components between the key ones, it was proved that there are $m + 1$ common roots for equations 6.1, 6.2 and 6.3. These roots are included in the relative volatility boundaries such that:

$$\begin{aligned} \alpha_{LK} > \phi_1 > \alpha_{LK+1} \\ \vdots \\ \alpha_{HK-1} > \phi_{m+1} > \alpha_{HK} \end{aligned} \quad (6.12)$$

Once the common roots are identified, eq. 6.2 or 6.3 can be written for the $m + 1$ roots. The system of $m + 1$ equations obtained, for example considering the eq. 6.5, contains the unknown values of the recovery of all the distributing components (m), of the recovery of the light and heavy keys (2) and the minimum vapor flow rate or

the minimum reflux ratio value (1). Thus we have a total of $m + 3$ unknowns. Namely, all non sharp calculations have 2 degree of freedom.

To solve the system it is necessary to fix the boundary values for the recovery of the light and heavy keys in the distillate or the recovery of other 2 components. These values are related to the required purity of the product streams and, as explained later, they define the feasible space that includes all the possible design space. The resulting linear system has the following form:

$$\begin{bmatrix} a_1(\phi_1) & \dots & a_m(\phi_1) & 1 \\ a_2(\phi_2) & \dots & a_m(\phi_2) & 1 \\ \vdots & \vdots & \vdots & \vdots \\ a_{m+1}(\phi_{m+1}) & \dots & a_m(\phi_{m+1}) & 1 \end{bmatrix} \cdot \begin{bmatrix} \xi_1 \\ \xi_2 \\ \vdots \\ V_{\min} \end{bmatrix} = \begin{bmatrix} \bar{b}_{NMC}(\phi_1) \\ \bar{b}_{NMC}(\phi_2) \\ \vdots \\ \bar{b}_{NMC}(\phi_{m+1}) \end{bmatrix} \quad (6.13)$$

where:

$$a_k(\phi_k) = -\frac{\alpha_k f_k}{\alpha_k - 1} \quad (6.14)$$

$$\bar{b}_{NMC} = \sum_{i \in NMC} \frac{\alpha_i \xi_i f_i}{\alpha_i - \phi_j} \quad (6.15)$$

The system can be solved using the Gauss-Jordan algorithm. Also if the procedure is general and independent from the number of feed components, in our case the separation of 3 component ABC mixture is considered with the components ordered in the decreasing value of volatility.

Choosing to fix the recoveries (or the component molar flow rates) of components A and B, from the system 6.13 the minimum vapor flow rate and the recovery (or the component molar flow rate) of the third component C are obtained. In the case that a negative value of the component recovery is obtained, the heavy key component will not longer appear in the distillate and the second Underwood's root becomes inactive. Only a single Underwood's equation is needed to obtain the minimum vapor flow rate. The minimum number of theoretical stages at total reflux can be obtained with the Fenske equation developed considering a constant value of the relative volatility and applicable to any pair of components:

$$N_{p \min} = \frac{\log\left(\frac{d_{pA}}{f_A - d_{pA}} \cdot \frac{f_B - d_{pB}}{d_{pB}}\right)}{\log\left(\frac{\alpha_A}{\alpha_B}\right)} \quad (6.16)$$

Once that the minimum number of theoretical stages is obtained for components A and B, it is possible to re-write the Fenske equation for components B and C and to evaluate the recovery (or the component molar flow rate) of C or, in the general case, of the same component estimated from the Underwood equation:

$$N_{p,m} = \frac{\log\left(\frac{d_{p,B}}{f_B - d_{p,B}} \cdot \frac{f_C - d_{p,C}^{Fenske}}{d_{p,C}^{Fenske}}\right)}{\log\left(\frac{\alpha_B}{\alpha_C}\right)} \quad (6.17)$$

Once the amount of the component is known at the boundaries of the reflux ratio values (R_m and ∞), it is possible to obtain a reasonable estimate of the corresponding recovery of the component, for any reflux ratio value included in the definition range, using a linear interpolation according to $R/R + 1$.²⁰

$$d_{p,C} = \left(\frac{1 - \frac{R_p}{R_p + 1}}{1 - \frac{R_{p,m}}{R_{p,m} + 1}} \right) \cdot (d_{p,C}^{Underwood} - d_{p,C}^{Fenske}) + d_{p,C}^{Fenske} \quad (6.18)$$

To evaluate the number of theoretical stages corresponding to the effective reflux ratio, the Gilliland correlation²¹ can be used:

$$X_p = \frac{R_p - R_{p,m}}{R_p + 1} \quad (6.19)$$

$$Y_p = 1 - \exp\left[\frac{(1 + 54.4X_p)(X_p - 1)}{(11 + 117.2X_p)X_p^{0.5}} \right] \quad (6.20)$$

$$N_p = \frac{Y_p + N_{p,m}}{1 - Y_p} \quad (6.21)$$

To complete the design for the prefractionator column it is necessary to define the feed location and at this scope the flow rates of all components in the bottom and distillate streams are required. These values are obtained from the material balances around the considered unit:

$$b_{p,A} = f_A - d_{p,A} \quad (6.22)$$

$$b_{p,B} = f_B - d_{p,B} \quad (6.23)$$

$$b_{p,C} = f_C - d_{p,C} \quad (6.24)$$

Then the prefractionator feed plate can be identified using the Kirkbride²² equation:

$$\frac{n_p}{r_p} = \left[\left(\frac{b_{p,A} + b_{p,B} + b_{p,C}}{d_{p,A} + d_{p,B} + d_{p,C}} \right) \left(\frac{f_A}{f_C} \right) \left(\frac{b_{pA}}{d_{pC}} \right)^2 \left(\frac{d_{p,A} + d_{p,B} + d_{p,C}}{b_{p,A} + b_{p,B} + b_{p,C}} \right)^2 \right]^{0.206} \quad (6.25)$$

For the modeling of the other columns, different approaches are reported in the literature. For instance, Triantafyllow and Smith⁸ consider an equilibrium model to calculate the composition of the interconnecting streams.

As indicated in Fig. 6.3 the blue stream from the condenser of the prefractionator column is related to the distillate by the following equilibrium equation, obtained for ideal mixtures:

$$x_i = \frac{y_i / \alpha_{ij}}{\sum_i \frac{y_i}{\alpha_{ij}}} \quad (6.26)$$

In the same way the blue stream from the reboiler of the prefractionator is related to the residue stream by the following equilibrium equation:

$$y_i = \frac{x_i \alpha_{ij}}{\sum_i x_i \alpha_{ij}} \quad (6.27)$$

Once the flow rates and the compositions of all the streams of the prefractionator are obtained, from equilibrium relations and material balances it is possible to apply the Underwood's method to the other columns considering the modification for column with a side stream already proposed by King.²⁰

In our work we consider the approach of Carlberg and Westerberg^{16,17} that has been utilized also by other researchers.²³ The connection between the prefractionator and the downstream columns was considered as a net stream that satisfies the balances reported in eqs 6.28 and 6.29 and the Underwood equations are derived considering the net product streams from the prefractionator column.

$$D_p = V_p - L_p \quad (6.28)$$

$$B_p = \bar{L}_p - \bar{V}_p \quad (6.29)$$

The column 1 in Fig. 6.3 performs a sharp separation between the lightest component A and the middle boiling one B. No distributing components are present,

only one Underwood root is active and included between the relative volatilities of the key components.

For this column the feed equation is modified according to the net stream from the prefractionator column:

$$\sum_i \frac{\alpha_i \cdot d_{pi}}{\alpha_i - \theta_j} = D_p \cdot (1 - q_1) \quad (6.30)$$

The feed quality can be calculated from its definition, using the subscripts according to the column number or name, and written as:

$$q_1 = \frac{\bar{L}_1 - L_1}{D_p} \quad (6.31)$$

$$L_1 = L_p + \bar{L}_1 \quad (6.32)$$

Substituting eq. 6.32 in 6.31:

$$q_1 = \frac{-L_p}{D_p} = -R_p \quad (6.33)$$

Similarly, column 2 performs the sharp separation between the components B and C. The Underwood's feed equation, modified as follow, can be solved to obtain the single active root:

$$\sum_i \frac{\alpha_i \cdot b_{pi}}{\alpha_i - \psi_j} = B_p \cdot (1 - q_2) \quad (6.34)$$

As in the previous case, the feed quality can be obtained from the general definition and considering the connection between the prefractionator and the column 2.

$$1 - q_2 = \frac{\bar{V}_2 - V_2}{B_p} \quad (6.35)$$

$$\bar{V}_2 = V_2 + V_p \quad (6.36)$$

$$q_2 = \frac{V_p}{B_p} + 1 = S_p + 1 \quad (6.37)$$

From the Underwood's calculations it is possible to obtain the minimum reflux ratio value for columns 1 and 2, and then the procedure follows the calculation steps described for the prefractionator.

6.4.1 Feasible Design Space and Optimization

The system described, equivalent to a Petlyuk column, is a complex structure in which the parameters of one column influence the performance of the whole system. With the exception of Muralikrishna et al.²³ the works addressed to this topic^{7,17} do not put in evidence a feasible design space including all the possible parameters or do not consider effective parameters like operative reflux ratios to obtain a first attempt for more rigorous analysis methods.

To this regard the DWC model utilized in this work was based on the Muralikrishna et al. work and applied in a distillation sequence for a four component separation. To utilize the three column scheme reported in Figure 6.3, to model the Petlyuk system or the DWC, some considerations are necessary.

First, it is possible to merge column 1 and 2 if the vapor flow rate in the stripping section of column 1 equals the vapor flow rate of the rectifying section of column 2:

$$\bar{V}_1 = V_2 \quad (6.38)$$

Another common condition in this configuration, is the equality of the number of stages on each side of the internal wall. This condition is not strictly necessary but is derived from a more practical mechanical design and for the necessity to maintain a high mechanical column stability.

$$N_p = r_1 + n_2 \quad (6.39)$$

Owing to conditions 6.38 and 6.39, the design parameters for columns 1 and 2 can not be fixed in an independent way. Considering the Gilliland correlation reported in eqs. 6.19-6.21, the number of theoretical stages are related to the effective reflux ratio value, thus to satisfy the imposed bounds it is necessary to consider a relation between the reflux ratio of columns 1 and 2. The procedure to develop this relation, is here reported:²³

$$\bar{V}_1 = V_2 = (V_1 - V_p) = D_1(R_1 + 1) - D_p(R_p + 1) \quad (6.40)$$

$$V_2 = D_2(R_2 + 1) \quad (6.41)$$

Substituting eq. 6.41 in 6.40 and making R_2 explicit, the relation between the columns reflux ratio derived from the bound 6.38 can be obtained:

$$R_2 = \frac{D_1}{D_2}(R_1 + 1) - \frac{D_p}{D_2}(R_p + 1) - 1 \quad (6.42)$$

Once that all the reflux ratios are obtained, the Gilliland and the Kirkbride equations for the number of theoretical stages and for the feed location, respectively, can be

applied to complete the design. The reflux ratio of the column 1 is chosen in an iterative way until condition 6.39 is reached.

To define the operational design space, component distribution considerations are necessary:

1. the prefractionator distillate flow rate of component A is higher than or equal to the same component flow rate in column 1;

$$d_{pA} \geq d_{1A} \quad (6.43)$$

2. the prefractionator distillate flow rate of component B is higher than or equal to the same component flow rate in column 1;

$$d_{pB} \geq d_{1B} \quad (6.44)$$

3. the maximum quantity of component A in the prefractionator distillate flow rate is limited from the A quantity in the feed;

$$d_{pA} \leq f_A \quad (6.45)$$

4. the B quantity in the bottom of the prefractionator must be at least equal to the B quantity in the bottom of column 2;

$$\begin{aligned} b_{pB} = (f_B - d_{pB}) &\geq b_{2B} \\ d_{pB} &\leq f_B - b_{2B} \end{aligned} \quad (6.46)$$

The constraints 6.43-6.46 represent in a d_{pA} ; d_{pB} space a rectangular zone including the feasible design space. The location of these constraints is not affected by the choice of the prefractionator's reflux ratio; in fact a material balance considering the design specification together with the whole system represented in Fig. 6.2, gives the following set of equations:

$$\left\{ \begin{array}{l} \frac{d_A}{d_A + d_B} = x_{D,A} \\ \frac{m_B}{m_A + m_B + m_C} = x_{M,C} \\ \frac{b_C}{b_B + b_C} = x_{B,C} \\ \frac{m_A}{m_C} = \frac{x_{M,A}}{x_{M,C}} \\ f_A = d_A + m_A \\ f_B = d_B + m_B + b_C \\ f_C = m_C + b_C \end{array} \right. \quad (6.47)$$

In a generic design problem the feed specifications are defined and also the product quality specifications are known, so only the component distributions in the column outputs are unknown. It should be noted that once that the column output flow rates are obtained from the system 6.47, these values are related to the outputs of the equivalent system reported in Fig. 6.3. For example d_A corresponds to d_{1A} , d_B to d_{1B} and so on; all these values are independent from the reflux ratio assumed.

After the design space is identified, the column design with the short-cut method described can be initialized. It must be pointed out that other three constraints, derived from the distribution of component C, the feasible reflux ratio for the prefractionator and the minimum number of plates, must be identified. In particular it is necessary that:

5. the flow rate of B from the bottom of the prefractionator should be equal to or higher than the quantity of the same component in the residue of column 2:

$$\begin{aligned} b_{pC} &= (f_C - d_{pC}) \geq b_{3C} \\ d_{pC} &\leq f_C - b_{3C} \end{aligned} \quad (6.48)$$

6. the feasible design space must include all the cases with a reflux ratio of the prefractionator higher than the correspondent minimum value:

$$R_p \geq R_p \quad (6.49)$$

7. The number of stages for the prefractionator must be less than the sum of the stages corresponding to the stripping and rectifying sections of column 1 and 2 respectively obtained from the Fenske and Kirkbride equations:

$$(p_1 + n_2)_m \leq N_p \quad (6.50)$$

The space, identified according to all the previous bounds, includes also a subspace corresponding to the condition of absence of heavy key component in the distillate of the prefractionator. This case corresponds to the inactivity of the Underwood root included between the relative volatilities of the middle and the heaviest components. The inactivity of one root does not represent a new constraint in the definition of the design space but simply divides the design space in two regions where a different number of Underwood's roots are active.

Once the feasible design space is identified, it is necessary to define an objective function to select attractive design options for a rigorous simulation. The objective function chosen to this scope is a simplified function of the total annual cost that gives the total cost the distillation column expressed as \$/lb mole of distillate:²⁴

$$TAC = \frac{C_1}{v_a T \eta} N_{tot} (1 + R_1) + \frac{C_2}{TV_{c,r}} (1 + R_1) + C_3 (1 + R_1) \quad (6.51)$$

The total annual cost function considered is composed by three terms: the first considers the installation cost of the distillation column and its internals, the second the cost of the heat exchanger area for condenser and reboilers, and the last one the utility cost needed to provide the vapour stream in the bottom and the reflux at the top of the column. It should be noted that this relation was originally developed for simple column configurations but, in the case of Petlyuk columns, no simplified expressions are available and probably for these kinds of systems the internal column costs are higher compared to the simple column configuration due to the internal wall. Anyway at this stage of evaluation, and taking into account that a short-cut method is used for the design, this approximation seems reasonable for a first selection of trial design parameters.

The parameters of the cost function are reported in Table 6.2, their meanings are specified in the notation section:

<i>Cost function parameters</i>	<i>Value</i>
C_1 [\$/ft ² plate yr]	27.5
C_2 [\$/ft ² yr]	1.65
C_3 [\$/lb mole]	0.00935
T [hr/yr]	8000
η	0.90
v_a [lb mole/ hr ft ²]	15
S_c [lb mole/hr ft²]	0.1

Table 6.2: Cost parameters of function 6.51.

6.5 Design Results

In this section the short-cut method and the rigorous simulations results, obtained for each composition case reported in Table 5.2, are compared. For the five composition cases two structures, obtained by substituting two columns from the already selected best simple column configuration, are evaluated. The former is obtained by maintaining the first simple column combined with a DWC (*SC+DWC*). In the second case the DWC is followed by the last column of the corresponding simple column configuration (*DWC+SC*). The DWC pressure has been selected as the greatest among the pressures of the simple columns replaced in the new hybrid structure. Both the possible hybrid structures are compared in terms of TAC value to

select the most energy saving configuration. Differences among the short-cut and the rigorous models are referable to the approximations introduced in the short-cut method.

6.5.1 Composition Case 1

In this composition case the excess of the lightest component is considered. The first structure examined is the SC+DWC. The first SC performs the separation A/BCD and in the DWC the other three components are separated. The comparison between the main parameters obtained from the short-cut model and the rigorous simulation to reach the same purity targets, is reported in Figure 6.4.

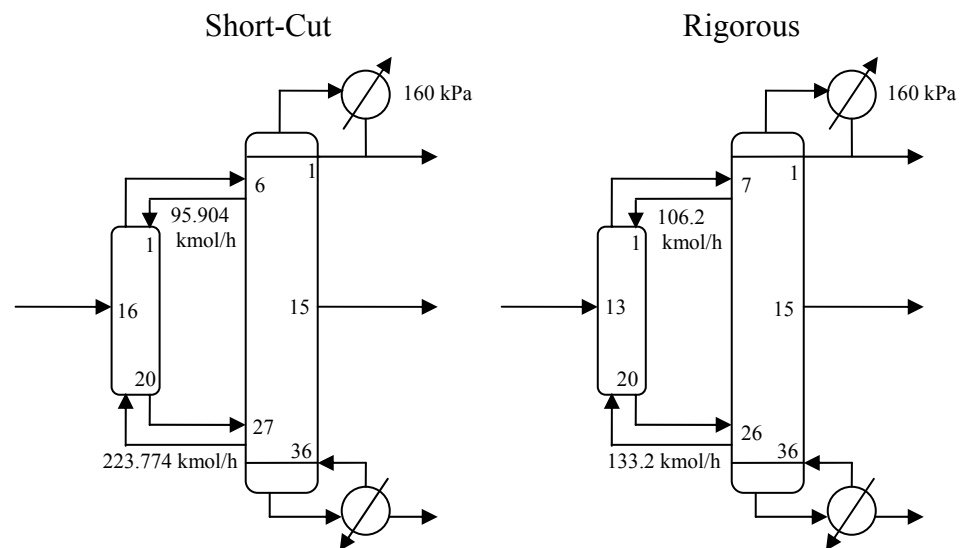

Figure 6.4: Comparison between the short-cut and the rigorous results for the structure SC+DWC in the composition case 1.

The other possible structure is the DWC+SC, in this case from the distillate stream of the divided wall column it is possible to obtain the component A, from the middle stream the component B and from the bottom a mixture CD. This stream is fed to the simple column that performs the separation C/D. In this case was not possible to obtain the required purity for the middle component B and the configuration was not taken into account for the TAC evaluation.

Utilizing the rigorous simulation it is possible to perform the TAC evaluation according to the methodology reported in Appendix A. The results are reported in Table 6.3.

Configuration	TAC 10^6 [\$/yr]
Best SC	3.06
SC+DWC	2.84
DWC+SC	---

Table 6.3: TAC values comparison between the best SC configuration and the two hybrid ones.

6.5.2 Composition Case 2

The excess of heaviest component is now considered. As in the previous case two structures are evaluated. Considering first the structure SC+DWC the SC performs the separation of the most plentiful component, ABC/D and from the DWC it is possible to separate the other three components. In Figure 6.5 the comparison between the results with the short-cut and the rigorous simulation is reported.

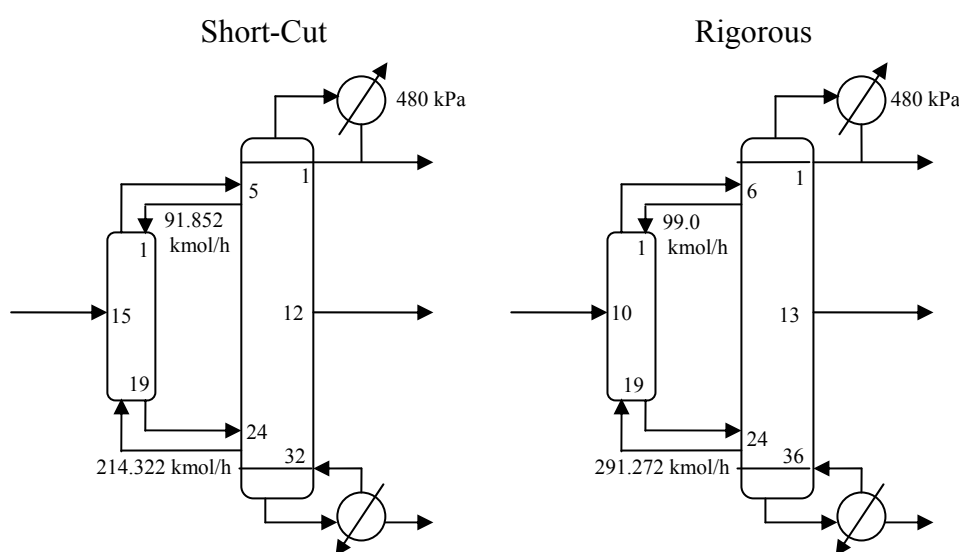

Figure 6.5: Comparison between the short-cut and the rigorous results for the structure SC+DWC in the composition case 2.

In the DWC+SC structure the first column separates the heaviest component in the bottom stream, C in the middle stream and a mixture AB as a distillate. This stream is fed to a simple column where the separation A/B takes place. Considering this structure the purity specification of the middle component C can not be reached and for this reason was not considered for the TAC evaluation. The comparison between the TAC values is reported in Table 6.4.

Configuration	TAC 10^6 [\$/yr]
Best SC	3.08
SC+DWC	3.00
DWC+SC	---

Table 6.4: TAC values comparison between the best SC configuration and the two hybrid ones.

6.5.3 Composition Case 3

In the case of an equimolar feed composition the comparison between the short-cut and the rigorous model for both the structures considered is reported in Figure 6.6 and 6.7.

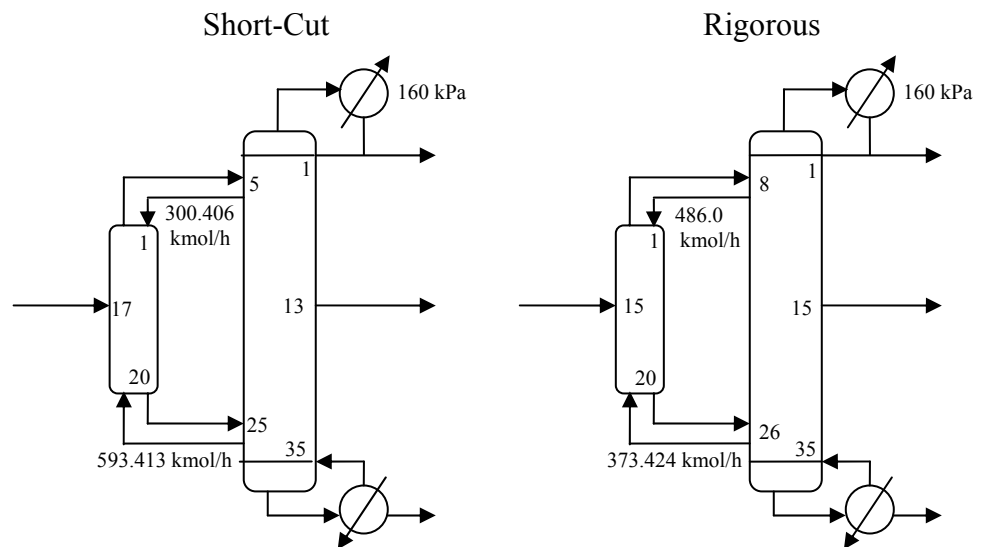

Figure 6.6: Comparison between the short-cut and the rigorous results for the structure SC+DWC in the composition case 3.

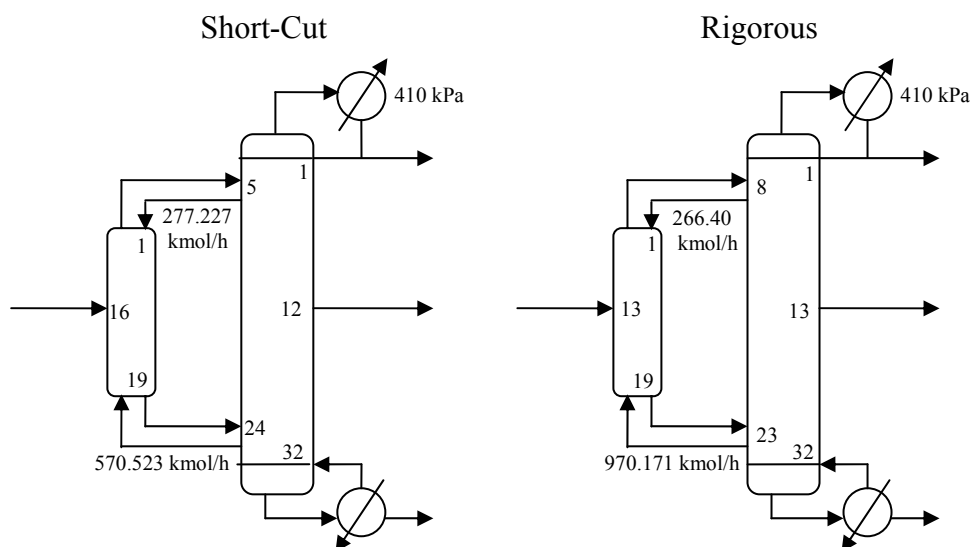

Figure 6.7: Comparison between the short-cut and the rigorous results for the structure DWC+SC in the composition case 3..

In the structure SC+DWC the first column performs the separation A/BCD and from the DWC it is possible to obtain the other three components. In the case of a DWC followed by a SC, from the first column it is possible to obtain A as the distillate, B from the middle stream and a mixture BC from the bottom stream that is fed to the SC for the B/C separation.

The TAC values for the best SC configuration and for the two hybrid structures are reported in Table 6.5.

Configuration	TAC 10^6 [\$/yr]
Best SC	3.64
SC+DWC	3.55
DWC+SC	3.97

Table 6.5: TAC values comparison between the best SC configuration and the two hybrid ones.

6.5.4 Composition Case 4

In this composition case the two middle components B and C are in equal excess compared to the other two. The structure SC+DWC performs the separation A/BCD in the first simple column and the mixture BCD is separated in the DWC. In the opposite case from the first DWC it is possible to obtain the components A and B respectively from the distillate and from the middle stream, the mixture CD is fed to

the simple column where the separation C/D takes place. The comparison between the short-cut and the rigorous model is reported in Figure 6.8 and 6.9.

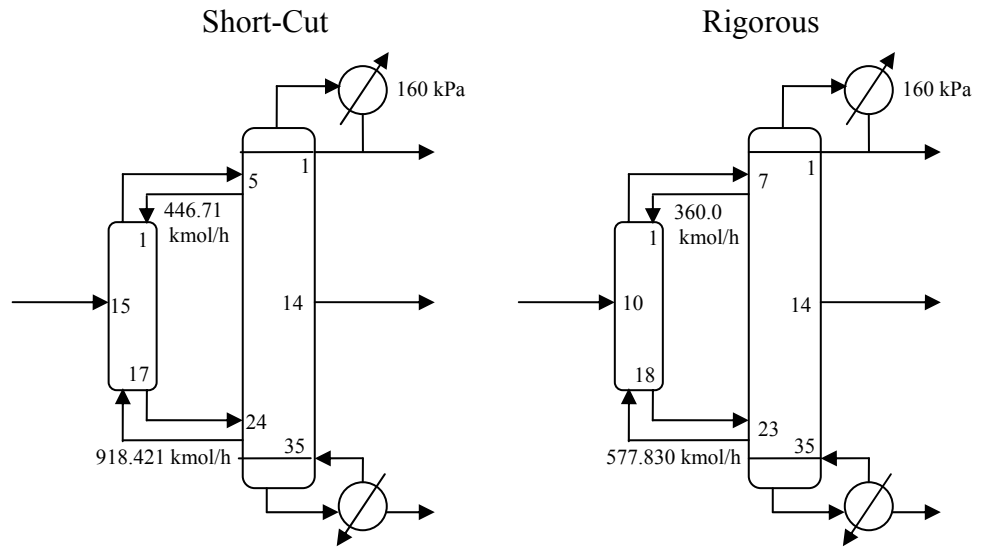

Figure 6.8: Comparison between the short-cut and the rigorous results for the structure SC+DWC in the composition case 4.

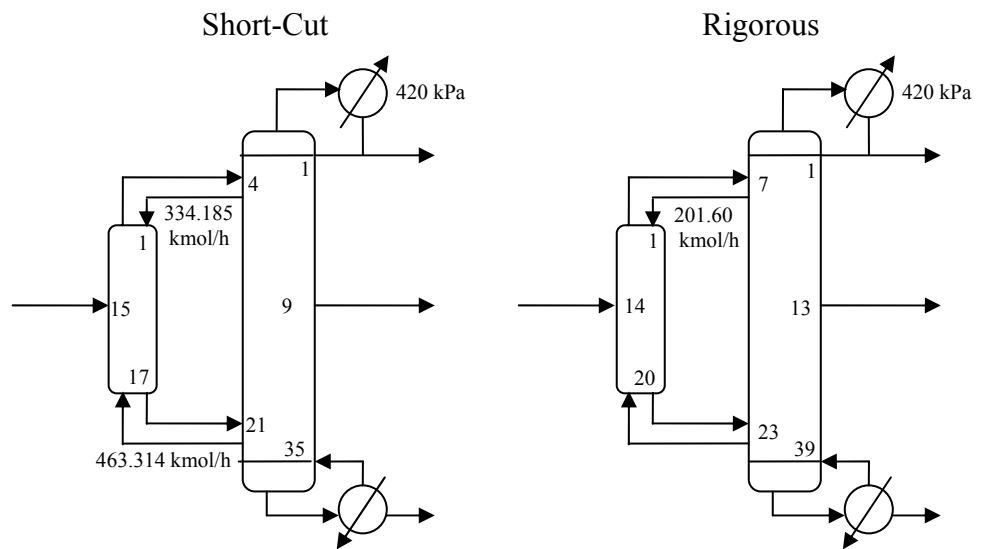

Figure 6.9: Comparison between the short-cut and the rigorous results for the structure DWC+SC in the composition case 4.

Table 6.6 reports the comparison between the TAC values of the considered sequences.

Configuration	TAC 10⁶ [\$/yr]
Best SC	3.90
SC+DWC	4.67
DWC+SC	3.56

Table 6.6: TAC values comparison between the best SC configuration and the two hybrid ones.

6.5.5 Composition Case 5

The last composition case regards a feed with the lightest and heaviest components in equal excess. Considering the SC+DWC structure, where the lightest component is separated first and the mixture BCD is fed to the DWC, it was not possible to reach the purity targets for the B and C streams. In the DWC+SC structure the component A is removed as distillate and D as bottom stream from the divided wall column. The middle stream containing the components B and C is fed to the simple column for the last separation. Also in this case it was not possible to reach the purity target for component C and thus these configurations were not taken into account for the TAC evaluation.

6.6 Final Considerations

From the results obtained for the single composition cases it is possible to derive some general observations. In the composition cases 1 and 3, the direct sequence is the best simple column sequence. In the SC+DWC the DWC is fed with an equimolar mixture of components B, C and D, anyway only in the composition case 1 an appreciable cost reduction was observed. The reason can be attributed to the different DWC feed flow rates that characterizes the two cases. This fact affects the internal column distribution of flows from which the diameter of the column depends. For composition case 1 the DWC feed is of about 300 kmol/h and the correspondent diameter is 2.05m, for case 3 instead, the feed flow rate is of about 750 kmol/h that requires a 3.52 column diameter. For the composition case 2 the best simple column configuration was the indirect one and once more, considering the SC+DWC sequence, the DWC is fed with an equimolar mixture. In this case however, the components are A, B and C and for this reason the column was forced to operate at the highest pressure of the simple column configuration with a consequent decreasing in the separation easiness. The corresponding TAC value is about the same than for the best simple column configuration.

From the examination of these three composition cases it is possible to say that it can be convenient to operate with the hybrid structure SC+DWC in the case that the simple column performs the separation of the lightest component and the DWC is fed with a limited flow rate of the equimolar mixture. For case composition 4 where the two middle components are in equal excess compared to the lightest and heaviest ones the most convenient structure is the DWC+SC. In this case the component B is removed in the middle stream from the DWC. The saving on the total annual cost with respect to the best SC sequence is about 10% confirming the heuristic that recommends the use of the DWCs in the case of mixtures with an excess in the middle boiling component. In all the other structures considered it was not possible to reach the separation targets or the TAC values were not convenient. In particular for the composition case 5 neither the SC+DWC and the DWC+SC structures were able to satisfy the middle stream purity target.

In conclusion, the combination of a simple column with a divided wall column for the separation of four components mixtures seems to be convenient only for a few composition cases and it appears of relevant importance the position of the DWC inside the separation sequence.

6.7 Notation

a = generic coefficient of the system

B = bottom flow rate

b = molar component flow rate in the column bottom stream

\bar{b} = generic known term of the system

C_1 = annual incremental unit investment cost

C_2 = annual incremental unit investment cost in condenser and reboiler equipment

C_3 = cost of steam and coolant to vaporize and condense, respectively one lb mole of distillate

D = distillate flow rate

d = molar component flow rate in the column distillate stream

L / \bar{L} = liquid molar flow rate in the rectifying/stripping column section

q = quality of the feed

F = feed flow rate

f = molar component flow rate in the feed stream

M = DWC side stream molar flow rate

m = molar component flow rate in the DWC side stream

N = number of theoretical stages

n = number of stages in the stripping column section

V / \bar{V} = vapour molar flow rate in the rectifying/stripping column section

R = molar reflux ratio

r = number of stages in the rectifying column section

S = molar boil up reflux ratio

$V_{c,r}$ = vapour-handling capacity of the condenser and reboiler equipment combined

T = apparatus working time

TAC = total annual cost [\$/lb mole]

X, Y = Gilliland correlation parameters

x = molar fraction

α = relative volatility

v_a = allowable vapour velocity

η = fractional column tray efficiency

ζ = recovery fraction

Φ = Underwood's root

6.7.1 Subscripts

A,B,C = components identification letter

HK = heavy key component

LK = light key component

m = minimum variable value

NMC = non middle key components

p = prefractionator

1, 2 = identifier column number

6.8 References

- (1) Wright, R.O. U.S. Patent 2471134, **1949**.
- (2) Agrawal, R. More Operable Fully Thermally Coupled Distillation Configurations for Multicomponent Distillation. *Trans IChemE* **1999**, 77(Part A), 543.
- (3) Halvorsen, I. J.; Skogestad, S. Optimizing Control of Petlyuk Distillation: Understanding the Steady –State Behaviour. *Comp. Chem. Engng.* **1997**, 21, S249.
- (4) Parkinson, G.; Kamiya, T.; D'Aquino, R.; Ondrey, G. The Divided in Distillation. *Chem. Eng.* **1999**, April, 32.
- (5) Christiansen, A. C.; Skogestad, S.; Lien, K. Complex Distillation Arrangements: Extending the Petlyuk Ideas. *Comp. Chem. Engng.* **1997**, 21, S237.
- (6) Rong, B.G.; Turunen, I. Synthesis of New Distillation Systems by Simultaneous Thermal Coupling and Heat Integration. *Ind. Eng. Chem. Res.* **2006**, 45, 3830.

- (7) Tryantafyllou, C.; Smith R. The Design and the Optimization of Fully Thermally Coupled Distillation Columns. *Trans. Inst. Chem. Eng.* **1992**, 70(Part A), 118.
- (8) Fidkowski, Z. T.; Krolikowski, L. Minimum Energy Requirements of Thermally Coupled Distillation Systems. *AIChE J.* **1987**, 33, 654.
- (9) Agrawal, R.; Fidkowski, Z. T. Are Thermally Coupled Distillation Columns Always Thermodynamically more Efficient for Ternary Distillation? *Ind. Eng. Chem. Res.* **1998**, 37, 3444.
- (10) Agrawal, R.; Fidkowski, Z. T. More Operable Arrangements of Fully Thermally Coupled Distillation Columns. *AIChE J.*, **1998**, 44, 2565.
- (11) Lestak, F.; Collins, C. Advanced Distillation Saves Energy & Capital. *Chem. Eng.* **1997**, July, 72.
- (12) Beker H.; Godorr, S.; Kreis, H. Partitioned Distillation Columns-Why, When & How. *Chem. Eng.* **2002**, January, 68.
- (13) Becker, H.; Godorr, S.; Kreis, H.; Vaughan, J. The World's Largest Partitioned Column with Trays-Experience from Conceptual Development to Successful Start-Up. *Reports on Science and Tech.* **2000**, 62, 42.
- (14) Schultz, M. A.; Stewart, D. G.; Harris, J. M.; Rosenblum, S. P.; Shakur, M. S.; O'Brien, D. Reduced Costs with Dividing-Wall Columns. *CEP* **2002**, May, 64.
- (15) Parkinson, G. Drip and Drop in Column Internals. *Chem. Eng.* **2000**, July, 27.
- (16) Carlberg, N. A.; Westerberg, A. W. Temperature-Heat Diagrams for Complex Columns. 2. Underwood's Method for Side Strippers and Enrichers. *Ind. Chem. Eng. Res.* **1989**, 28(9), 1379.
- (17) Carlberg, N. A.; Westerberg, A. W. Temperature-Heat Diagrams for Complex Columns. 3. Underwood's Method for the Petlyuk Configuration. *Ind. Chem. Eng. Res.* **1989**, 28(9), 1386.
- (18) Underwood, A. J. Fractional Distillation of Multicomponent Mixtures-Calculation of Minimum Reflux Ratio. *J. Inst. Petrol.* **1946**, 32, 614.
- (19) King, C. J. **1980**, Separation Processes, 2nd ed., McGraw-Hill.
- (20) Treybal, R. E. **1980**, Mass Transfer Operations, 3rd ed., McGraw-Hill.
- (21) Gilliland, E. R. Optimum Feed-Plate Composition in Multicomponent Rectification. *Ind. Eng. Chem.* **1940**, 32, 918.
- (22) Kirkbride, C. G. Process Design Procedure for Multicomponent Fractionators. *Petr. Ref.* **1944**, 23(9), 321.
- (23) Muralikrishna, K., Madhavan, K. P., Shah, S.S. Development of Dividing Wall Distillation Column Design Space for a Specified Separation. *Trans IChemE*, **2002**, 80(Part A), 155.
- (24) Happel, J.; Jordan, D. J. **1975**, Chemical Process Economics, 2nd ed., Marcel Dekker, INC..

Chapter 7

Synthesis of Distillation Sequences with Less than $n-1$ Columns

Mapping new subspaces to extend the searching space to identify the best distillation sequence to improve the energy performance of the plant is a topic of increasing interest. Since now, many works with different approaches are presented in the literature, but no one gives a general procedure to generate in a systematic way the subspace that includes the configurations with less than $n-1$ columns for the separation of n -component mixtures. In this chapter a simple process intensification method to generate these configurations is presented with particular emphasis on the benefit to keep the information about the correlation between the space of the simple column configurations and the new ones generated in the subspace. From this point of view the method has a great importance because can significantly reduce the computational time of analysis, allowing to choose for a more detailed analysis only the configurations derived from the best simple column configurations.

7.1 Introduction

Between the end of the 40's and the beginning of 50's the principal research area on distillation topic was the development of methodologies to give a good physical description of the process.^{1,2} After that, in the 70's, most of the research work was focused on the study of different possible arrangements to separate a n-component mixture using mainly simple columns.³ For the separation of an n-component mixture into n pure products, as the number of components increases the number of possible simple column configurations sharply increases. This was one of the main reasons that urged the researchers' work in searching general rules (heuristics) able to make a preliminary screening in order to select a lower number of alternatives to analyze. The selected configurations can be subsequently better analyzed with rigorous methods to find the best sequence in terms of energy requirement^{4,5} or of other selected parameters. Anyway heuristic rules are based on practical considerations from different plant experiences or from the generalization of the results of a large set of process design simulations studies, so their indications are not always valid and can lead to not optimal solutions.⁶ The problem of the analysis of all the possible separation sequences became more complex when some researchers, with the aim to reduce the energy consumption of a plant, started to propose again the use of the divided wall column patented by Wright⁷ in 1949. With the aim to lower the energy consumption, the searching space was also extended to the thermally coupled distillation sequences. The continue increasing in the energy costs motivates to improve the knowledge about these systems because, as it is known, distillation units are the most energy consuming plants in the chemical and petrochemical fields. The problem of energy consumption is not solved since now, so it is important to add knowledge about the design and the operability of these new distillation structures. The introduction in a distillation sequence, of one or more thermal couplings by removing condensers and/or reboilers associated to submixtures (non-product streams), extends the research space for the most energy saving configuration. The way to obtain a whole space of research is still a topic of discussion and many authors try to identify new configurations never predicted before. Different approaches are proposed in the literature. Caballero and Grossmann⁸ developed a superstructure for the generation of the possible configurations for the separation of a n-component mixture obtained with the state task network formalism. The search of the separation sequences with the best energy performance is selected modelling the superstructure with a generalized disjunctive programming that is able to solve the task independently from the used model (short-cut or rigorous). Other configurations were considered in a subsequent work

by the same authors,⁹ like the thermodynamically equivalent ones and in particular those configurations without problems of control due to pressure limitation in the transfer of vapour flow rate between two consecutive columns. This problem was already pointed out by Agrawal and Fidkowski.¹⁰ Agrawal¹¹ presented a method to generate the space of the possible configurations using the concept of distinct thermally coupled configuration for sequences with n-1 columns. Rong et al.¹² showed how, using the concept of intended individual split, it is possible to identify the space for the research of the most energy conservative sequence. Moreover some new configurations for quaternary distillation were added with respect to the searching space found by Sargent and Gaminibandara¹³ and Agrawal.¹⁴ This brief review of some of the works done in the searching of new configurations for the separation of an n-component mixture points out that to dispose of a mapping space as more complete as possible, is the first and main point of the synthesis of the process in order to satisfy a fixed objective. In particular by extending the searching space to new configurations it is possible to increase the possibility to identify the more energy saving structure,¹⁵ that is one of the more common objective for a distillation plant. Another important topic regarding the method utilized to obtain the searching space, is to maintain the information about the generation from one configuration to another. In this way each simple column can be considered as the root of the consequent sequences generated with a systematic method. In this work a method is presented for the systematic generation of sequences with less than n-1 distillation columns. This subspace of sequences was never explored in a complete way, and it is known that in some particular cases of feed composition, required product purity and relative volatility of components, the configurations with less than n-1 columns can reduce the energy consumption and the capital cost of a given separation task.^{16,17}

7.2 Synthesis Methodology

To describe the methodology to obtain the searching space of sequences with less than n-1 columns it is first necessary to make a brief review of the single steps necessary to obtain this family of configurations. The general procedure starts from the simple columns sequences, from which the thermally coupled configurations and then the thermodynamically equivalent structures are generated. All the configurations with less than n-1 columns can be finally obtained by substituting a side single column section with a vapour or a liquid drawing. In the following a column section is defined according to Hohmann¹⁸ as a portion of column that is not interrupted by entering or exiting streams or heat flows. Only sharp splits and nonazeotropic multicomponent mixtures are considered. Analyzing the method in

detail, the systematic procedure starts by drawing all the possible simple column configurations. It was already mentioned that for an n-component separation the number of simple column sequences (S_n) can be predicted with eq 4.1 developed by Thompson and King.³

In each simple sequence $2(n-1)$ heat exchangers are employed, n heat exchangers are associated with the n products while n-2 are associated with the submixtures of 2 or more components. When only sharp splits are considered, $2(n-1)$ columns sections are needed.¹⁹ The total number of thermally coupled schemes (P_n) can be calculated from the following formula developed for $n \geq 3$:²⁰

$$P_n = \frac{[2(n-1)]!}{n!(n-1)!} \left[\sum_{j=1}^{n-3} \frac{(n-2)!}{j!(n-2-j)!} + 1 \right] \quad (7.1)$$

Each thermally coupled configuration can be obtained from the corresponding simple column sequence by substituting one or more condenser/s and/or reboiler/s associated to no product streams with a bidirectional vapour-liquid connection. For sequences with more than one submixture it is possible to remove the corresponding heat exchangers one at the time or all together. In the former case a subfamily or a subspace of thermally coupled sequences is obtained with particular advantages in the energy saving and control performance, compared to the latter case where all the heat exchangers associated to submixtures are substituted with a thermal coupling.²⁰ From the thermally coupled sequences, the thermodynamically equivalent ones can be generated moving a column section associated to a condenser and/or a reboiler that provide the common reflux flow rate or the vapour boil up between two consecutive columns. Following this procedure the elimination of a condenser or a reboiler associated to a submixture from a simple column in a distillation sequence, makes movable the rectifying or the stripping section of the subsequent column. For this reason the number of movable sections is equal to the number of thermal couplings in the considered sequence.²¹ This space of configurations has the same energy requirement of the thermally coupled structures from which are generated, nevertheless capital cost saving can be achieved by a better liquid and vapour flow rate redistribution between the sections. Moreover a better controllability of the system can be obtained.¹⁰ For n-component mixtures the number of thermodynamically equivalent structures (TES) of a given sequence can be predicted utilizing the following formula developed by Rong et al.:²¹

$$TES = 2^{NTC} \quad (7.2)$$

Where NTC is the number of thermal couplings. At the beginning the space of thermodynamically equivalent structures is usually not explored when the best

saving structure is searched, because as said before, the energy requirement of these structures is the same of the thermally coupled configurations from which are derived.¹¹ However after that a promising structure is identified, only the corresponding thermodynamically equivalent structures should be considered for a possible capital cost reduction. Now from the thermodynamically equivalent structures it is possible to generate the new subspace of sequences with less than n-1 columns. The methodology is simple and consists in the elimination of the side columns having only one column section. As example, by considering the application for a 3 components mixture, there are two possible simple column configurations: the direct (DS) and the indirect one (DI), both reported in Figure 7.1.

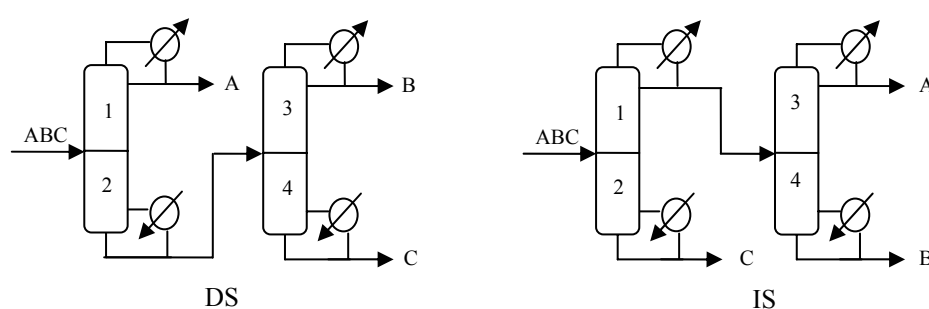

Figure 7.1. Direct Sequence (DS) and Indirect Sequence (IS) for a three components mixture.

From the direct sequence it is possible to generate the corresponding thermal coupled sequence (Figure 7.2.1) and the thermodynamically equivalent one (Figure 7.3.1). Then, by eliminating the single rectifying section of the second column by means of a side stream it is possible to obtain the single column configuration reported in Figure 7.4.1. It is clear that the configuration 7.4.1 descends from the direct simple configuration. In the case of 3 components mixture all the side streams are associated to the middle component product streams, but this consideration can not be always true when we increase the number of components. In fact for 4 or more component mixtures it is also possible to obtain thermodynamically equivalent structures with a single section column connecting two columns. In this case the corresponding sequence in the subspace of less than n-1 columns contains a side stream between two columns. Two different cases can be identified; in the first, two columns are connected through a single column section by two thermal couplings. The corresponding sequence with less than n-1 columns obtained by removing the single column section contains a thermal coupling between the considered columns.

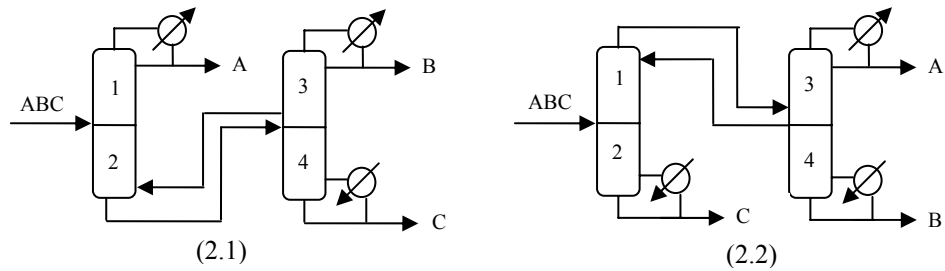

Figure 7.2. Partially coupled distillation sequences derived from the DS, (2.1) and from the IS, (2.2).

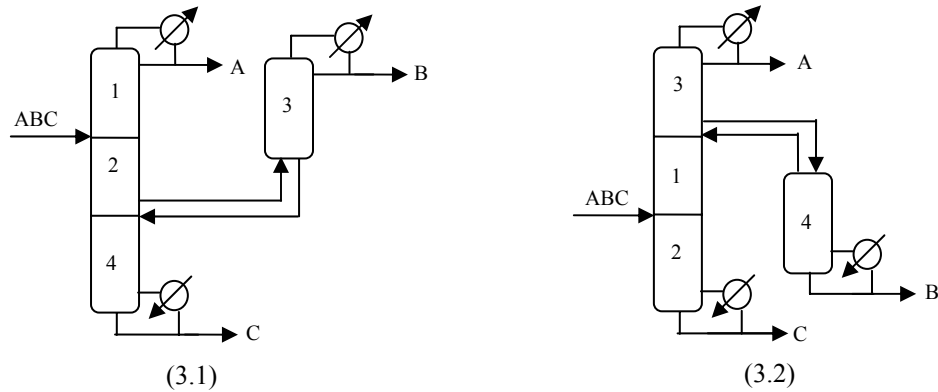

Figure 7.3. Thermodynamically equivalent configurations; (3.1) is derived from (7.2.1) and (3.2) from (7.2.2).

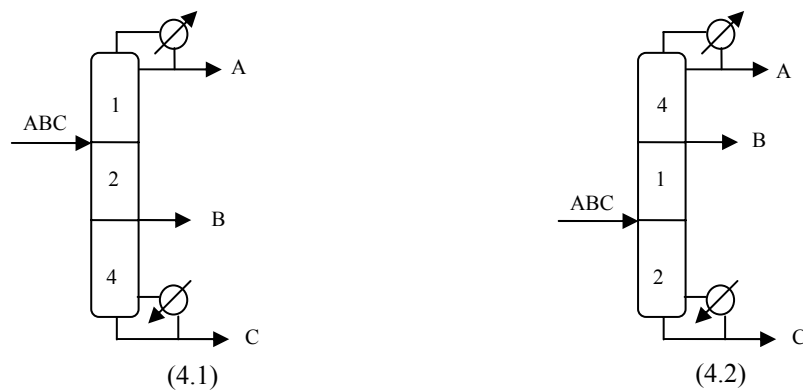

Figure 7.4. Configurations with less than n-1 columns derived respectively from Figures (7.3.1) and (7.3.2).

In the second case, if only one thermal coupling is present, the single column section is replaced with a simple side stream. The tray location of the withdrawal is made according to the section where the eliminated thermal coupling was placed. The physical state (liquid or vapour) of the side stream can also be identified. Because

the side stream always substitutes a thermal coupling its physical state strictly depends from the state of the stream connecting the column with the side one (vapour for a rectifying section, liquid for a stripping section).

Following this procedure the final configuration contains one column less than the minimum number and in some cases also one exchanger less than those of the partially coupled configuration from which is derived.

The method described is quite general and can be applied to the separation of any number of components. In the literature the subspace of configurations with less than $n-1$ columns was investigated for 3 and 4 components²²⁻²⁴ but the whole space was never systematically identified. To better explain the proposed method, all the configurations necessary to generate the subspace with less than $n-1$ columns in the case of a 4 components mixture are reported in Appendix B.

Figure B1 reports the 5 simple column configurations predicted according to eq 4.1. In Figure B2 the thermally coupled sequences generated by substituting one or more heat exchangers associated to submixtures are reported. The thermodynamically equivalent configurations obtained for each partially coupled sequence are reported in Figure B3. Then the sequences with less than $n-1$ columns can be generated, following the procedure described in the previous section. These sequences are reported in Figure B4. Table B1 is presented to evidence the connection between the different structures and their derivations with the notation utilized in the figures to identify the different configurations.

7.2.1 General Observations

By analyzing all the configurations presented, the following general observations valid also for more than 4 components, can be evidenced:

- a. Thermodynamically equivalent structures with more than one thermal coupling generate structures, in the subspace with less than $n-1$ columns, with at least one thermal coupling.
- b. From the direct configuration it is possible to generate structures with less than $n-1$ columns with only vapour side stream withdrawal. All the side streams are located below the feed. The reason is that for the generation of the thermal coupled sequences from the direct one it is possible to eliminate only reboilers and all the submixtures are associated to reboilers while all the condensers are associated with the product streams. The thermodynamically equivalent structures contain only rectifying side columns. The satellite columns are connected to the main ones with bidirectional liquid and vapour streams. The substitution of the side column

- is performed with a side stream of the same phase of the stream that connects the main column with the side one.
- c. The indirect configuration generates structures with liquid side stream located above the feed of the main column. In this case the thermodynamically equivalent structures contain only isolate stripping section.
 - d. From the direct and the indirect configurations it is possible to obtain, in the subspace of less than n-1 columns, a structure that contains a single column with 2 or more side stream.
 - e. From “hybrid” configurations (i.e. cases where the components are separated not in the relative volatility order) it is possible to obtain liquid side stream for structures derived from the direct one and vapour side stream for structures derived from the indirect one.
 - f. For the “pure” sequences (the direct and the indirect ones) the side streams are associated to product streams. In the hybrid configurations, instead, a side stream can connect one column to another. Also in this case the withdrawal is in liquid phase if located above the feed and in vapour phase if it is located below the feed.
 - g. The subspace with less than n-1 columns generated from symmetrical sequences contains both vapour and liquid side streams.

7.3 The Case Study

A four component mixture of propane, isobutane, normal butane and isopentane with the characteristics reported in Table 7.1 is considered to show the proposed methodology. This case study is already reported in a work by Elaahi and Luyben²⁵ addressed to study new complex structures to improve the energy performance of the traditional simple column sequences. The required product molar purities are 95% for propane and isopentane and 90% for isobutane and n-butane. In the present work all the simulations were performed by means of the package Aspen Plus 13.0. The initial design parameters like the number of theoretical stages, the feed location, the actual reflux ratio and the distillate flow rate were obtained from short cut calculations using the Winn-Underwood-Gilliland method implemented in the DSTWU Aspen model. A reflux ratio of 1.1 times the minimum value was considered for all the columns.

Component	Molar Fraction [%]	Physical Characteristic	
A, Propane	27.53	Temperature [K]	322
B, i-Butane	20.34	Vapour fraction	0
C, n-Butane	21.46		
D, i-Pentane	30.67		

Table 7.1: Feed characterization.

The pressure of each column was chosen to obtain a distillate bubble point of 50°C to use water-cooled overhead condenser to obtain the reflux and the liquid product. Then rigorous simulations were performed using the stage by stage model RADFRAC, optimizing the initial parameters obtained from the simplified calculation and considering a single sieve tray pressure drop of 0.1 psi.²⁶ In Table 7.2 the main design and operational parameters for all the possible simple column configurations, together with the thermal duties and the TAC values obtained as the sum of the annualized capital cost plus the annual operation cost, are summarized. The utilized energy price and all the data necessary to perform the TAC calculation are reported in Table 4.3. From Table 7.2 it is possible to notice that the symmetrical configuration has the less energy consumption and also the less TAC value. The subspace containing the configurations with less than n-1 column obtained from this simple column sequence is considered in detail and the results are reported in Table 7.3.

Configuration s1.1.1 with a liquid side stream above the feed of the first column has a higher energy consumption and also a higher TAC value compared to the symmetrical configuration. Sequence s3.1.1 was not considered for the economical calculation because it is similar to the previous one but with a thermal coupling between the columns. The introduction of the thermal coupling force to operate with the pressure of the first column, that is the highest one (1700 kPa), to assure a natural flow of the vapour stream; for this reason we expect a high TAC value. Similar considerations can be done for the sequence s3.3.3. This configuration has a lower energy request compared to the best simple column sequence (about of 6% of the total reboiler duty), but a higher value of the TAC because all the heat necessary for the separation is supply at the highest temperature. Configurations s3.3.1 and s3.3.2 are similar to this configuration but with one column section more than the s3.3.3 and they are awaited to be not convenient. Configuration s2.1.1 with a vapour side stream of n-butane below the feed of the first column has a less value of the TAC compared to the symmetrical configuration and can be a good alternative to perform the separation. The correspondent sequence s3.2.1 with a thermal coupling between the columns was also considered in detail. As expected the global energy

demand is lower than that of the s2.1.1 and of that the symmetrical sequence. The reduction of the total reboiler duty compared to the best simple column configuration is about 12%. Anyway the limitation on the pressure forces both columns to operate at a high pressure and for this reason the TAC value is higher.

	s1.1.1		s2.1.1		s3.2.1		s3.3.3
	C ₁	C ₂	C ₁	C ₂	C ₁	C ₂	C ₁
N _t	78	25	78	21	78	21	87
N _f	45	11	31	11	31	11	45
N _s	11	---	55	---	55	---	12/76
RR	9.70	2.55	3.85	1.01	---	8.75	9.70
P [kPa]	1700	500	1400	1700	1700	1700	1700
D [m]	6.80	2.70	6.68	2.28	7.38	4.83	7.81
Q _c [kW]	20769	8492	19365	3905	0	18942	20779
Q _r [kW]	26768	4717	25976	4606	26633	280	28765
TAC [\$ /yr]	6718633		6388697		7038715		7539520

Table 7.3: Design and operational parameters for the selected configuration of the subspace with less than n-1 columns.

7.4 Discussion

The synthesis methodology described presents some advantages compared to the way up to now followed in the literature to analyze the sequences with less than n-1 columns for the separation of multicomponent mixtures with 3 or more components, that are usually based on heuristic observations.^{16, 22, 24} First of all as already mentioned we are sure to have mapped the whole subspace of sequences with less than n-1 columns. For instance Kim and Wankat²⁴ in an interesting work addressed to identify the best sequences in terms of energy and capital costs, extend to a 4 components mixture the heuristic rules proposed by Tedder and Rudd for 3 components.¹⁶ These rules were developed from considerations about the feed composition and can be summarized as follow:

- when there is a small amount of A compared to B or little B and large C or little A and B and large amount of C in the feed, configurations with a liquid side stream above the feed are preferred;
- the configurations with a vapour side stream below the feed is preferred when the feed contains little quantity of D and large of C or little C and high B or small C and D and large amount of B;

	Direct			Indirect			Indirect-Direct			Direct-Indirect			Symmetrical		
	C ₁	C ₂	C ₃	C ₁	C ₂	C ₃	C ₁	C ₂	C ₃	C ₁	C ₂	C ₃	C ₁	C ₂	C ₃
N _t	21	57	19	29	61	21	29	19	57	21	22	58	67	21	18
N _f	11	29	11	15	31	11	15	10	30	11	13	29	34	11	11
RR	1.2	8	2.1	0.56	2.95	1.05	0.56	1.3	6.42	1.2	1.4	6.2	3.0	1.05	2.5
P [MPa]	1.7	0.8	0.5	1.0	1.4	1.7	1.0	1.7	0.8	1.7	0.65	0.8	1.4	1.7	0.5
D [m]	3.83	4.19	2.58	3.95	4.66	2.30	3.95	3.00	3.71	3.83	2.77	3.88	5.4	2.3	2.60
Q _c [MW]	4.31	17.66	7.40	10.36	15.71	3.98	10.63	4.50	14.64	4.31	10.56	14.04	15.97	3.98	294.34
Q _r [MW]	9.9	14.55	6.30	13.05	17.18	4.68	13.05	6.92	12.89	9.89	6.77	14.52	20.43	4.68	160.47
TAC [\$ /yr]	6457660			7267505			6862084			6547289			6425640		

Table 7.2: Design and operational parameters of the simple column configurations.

- the single column configuration may be applicable when there is a little quantity of A and D in the feed compared to the amount of B and C.

Considering these indications Kim and Wankat,²⁴ that excluded all the cases with thermal coupling, analyzed in their work, 11 configurations of the subspace with less than n-1 columns. It must be noted that they missed two possible configurations (d3.3.3, i3.3.3), those that we reported in Figure A2, that could be of interest according to the fact that there is a correspondence between the most energy saving simple column and the derived thermally coupled structures.^{19,27} One of the advantages of the generation method presented in this work is that it is possible to save the strict connection between the families of sequences and the way to associate the subspace with less than n-1 columns to the simple columns from which are derived. For instance Kim and Wankat,²⁴ in Example 1 where the feed composition was: 5% A, 25% B, 40% C and 30% D, considered for the comparison the performance of all the simple columns configurations and 9 sequences with less than n-1 columns. They select the symmetrical sequence as the best simple column configuration utilizing an appropriate index for the energy demand. Following the heuristic considerations of Tedder and Rudd already cited, for a feed with a little quantity of the lightest component, the configurations with a liquid side stream should be better than the vapour side stream configuration. The results obtained confirm this, but considering the correspondence between the best simple sequence and the structures derived from this one, the comparison can be limited by choosing, among all the subspace with less than n-1 columns, only the configurations derived from the best simple column sequences (i.e. configurations in Figure 4 of the Kim and Wankat²⁴ work and Figure 8 and 12 that they did not considered in the example). This consideration can drastically reduce the number of simulations necessary and the time of analysis. Kim and Wankat²⁴ made a huge comparison including also configurations derived from not optimal simple sequences that of course generate not convenient configurations as it appears in Table 3 of the cited work. In fact the relative difference between configurations derived from the best simple column sequence and sequences derived from not optimal simple sequences is sometimes about 300 times the optimal value. Also the other examples reported in the cited work confirm the strict correspondence between the best sequence in the subspace of less than n-1 columns with the best simple column configuration. Nevertheless in some cases it could be better to consider more than one best simple column sequence, especially when there is a small difference in the values of the parameters used for the choice (see for instance the example 4 of the cited work). Moreover all the cases utilized in the cited work regard always feed mixtures with one or more components in small amount. In the case study considered in the present work a feed with a balanced composition is considered and it is difficult to

apply one of the heuristics already reported. Nevertheless a sequence that shows some advantages compared to the traditional simple column configuration was identified.

Further considerations can be done about the physical phase of the side stream withdrawal. Luyben²² introduces a general rule, afterwards followed by Tedder and Rudd,¹⁶ derived from an intuitive observation considering the volatility distributions of the components. They indicate that if the lightest component is present in small concentration it is convenient to take the middle component as a liquid in the rectifying section (above the feed) because the middle component is more concentrated in the liquid compared to the lighter one that is more concentrated in the vapour phase. The same consideration can be made for the stripping section and the withdrawal point of the middle component in the vapour phase (below the feed). In this case the liquid phase is rich in the heaviest component and it is indicated to take the middle component from the vapour flow. All these practical considerations are confirmed in the mapped subspace of new configurations as pointed out in the general synthesis methodology. The last observation that can be made is about the type of columns used in the subspace with less than $n-1$ columns. Following the procedure derived in the previous paragraph it is possible to generate a whole subspace including also configurations with columns connected to other ones by one or more thermal couplings.

7.5 Remarks

A systematic method for the generation of the subspace of distillation column sequences with less than $n-1$ columns is presented. This subspace includes sequences with simple side stream columns and also sequences with thermal couplings. The benefit to save the information between the families of configurations can lead to a less number of the alternatives to be compared to find the optimum configuration. The analysis of other works presented in the literature, that utilize this type of configurations, points out that the study of the correspondence between the simple column sequence and the new subspace is more reliable than the application of the heuristics developed by practical consideration or determinate by considering the results for 3 components separation. A specific case study on the separation of a four components mixture points out the potential in the cost reduction for some configurations of the identified subspace. The different solutions are compared not only in terms of the required heat duties but with the TAC values to take into account both capital costs and quality of the heat supplied. In fact some configurations with a less heat duty demand with respect to the simple column sequences have a higher TAC value. Anyway it is showed that for the

considered feed composition case it is possible to conveniently perform a four component separation employing only two columns. Another benefit that was not possible to quantify is the less space usage that in some industrial cases can be a limiting factor.

7.6 Notation

D = column diameter [m]
N_f = feed location
N_t = number of theoretical stages
N_s = side stream location
P = top column pressure [kPa]
Q_c = condenser duty [kW]
Q_r = reboiler duty [kW]
RR = molar reflux ratio

7.7 References

- (1) Underwood, A. J. V. Fractional Distillation of Multicomponent Mixtures-Calculation of Minimum Reflux Ratio. *J. Inst. Petrol.* **1946**, 32, 614.
- (2) Shiras, R. N.; Hanson, D. N.; Gibson, C. H. Calculation of Minimum Reflux in Distillation Columns. *Ind. Eng. Chem.* **1950**, 42(5), 871.
- (3) Thompson, R. W.; King, C. J. Systematic Synthesis of Separation Schemes. *AIChE J.* **1972**, 18(5), 941.
- (4) Nath, R.; Motard, R. L. Evolutionary Synthesis of Separation Processes. *AIChE J.* **1981**, 27(4), 578.
- (5) Nadgir, V. M.; Liu, Y. A. Studies in Chemical Process Design and Synthesis: Part V: A Simple Heuristic Method for Systematic Synthesis of Initial Sequences for Multicomponent Separations. *AIChE J.* **1983**, 29(6), 926.
- (6) Malone, M. F.; Glinos, K.; Marquez, F. E.; Douglas, J. M. Simple, Analytical Criteria for the Sequencing of Distillation Columns. *AIChE J.* **1985**, 31(4), 683.
- (7) Wright, R. O. Fractionation Apparatus. **1949**, *US Patent No. 2*, 471, 134.
- (8) Caballero, J. A.; Grossmann, I. E. Generalized Disjunctive Programming Model for the Optimal Synthesis of Thermally Linked Distillation Columns. *Ind. Eng. Chem. Res.* **2001**, 40, 2260.
- (9) Caballero, J. A.; Grossmann, I. E. Thermodynamically Equivalent Configurations for Thermally Coupled Distillation. *AIChE J.* **2003**, 49(11), 2864.
- (10) Agrawal, R.; Fidkowski, Z. T. More Operable Arrangements of Fully Thermally Coupled Distillation Columns. *AIChE J.* **1998**, 44(11), 2565.

- (11) Agrawal, R. Synthesis of Multicomponent Distillation Column Configurations. *AIChE J.* **2003**, 49(2), 379.
- (12) Rong, B. G.; Kraslawski, A.; Turunen, I. Synthesis of Functionally Distinct Thermally Coupled Configurations for Quaternary Distillations. *Ind. Eng. Chem. Res.* **2003**, 42, 1204.
- (13) Sargent, R. W. M.; Gaminibandara, K. Optimum Design of Plate Distillation Columns. In *Optimization in Action*; Dixon, L. W. C., Ed.; Academic Press, **1976**; p 267.
- (14) Agrawal, R. Synthesis of Distillation Column Configurations for a Multicomponent Separation. *Ind. Eng. Chem. Res.* **1996**, 35, 1059.
- (15) Rong, B. G.; Turunen, I. Synthesis of New Distillation Systems by Simultaneous Thermal and Heat Integration. *Ind. Chem. Eng. Res.* **2006**, 45, 3830.
- (16) Tedder, D. W.; Rudd, D. F. Parametric Studies in Industrial Distillation: Part I. Design Comparison. *AIChE J.* **1978**, 24(2), 303.
- (17) Doukas, N.; Luyben, W. L. Economics of Alternative Distillation Configurations for the Separation of Ternary Mixtures. *Ind. Eng. Chem. Process Des. Dev.* **1978**, 17(3), 272.
- (18) Hohmann, E. C.; Sander, M. T.; Dunhford, H. A New Approach to the Synthesis of Multicomponent Separation Schemes. *Chem. Eng Comm.* **1982**, 17, 273.
- (19) Rong, B. G.; Kraslawski, A. Partially Thermally Coupled Distillation Systems for Multicomponent Separations. *AIChE J.* **2003**, 49(5), 1340.
- (20) Rong, B. G.; Kraslawski, A. Optimal Design of Distillation Flowseets with a Lower Number of Thermal Couplings for Multicomponent Separations. *Ind. Chem. Eng. Res.* **2002**, 41, 5716.
- (21) Rong, B. G.; Kraslawski, A.; Turunen, I. Synthesis and Optimal Design of Thermodynamically Equivalent Thermally Coupled Distillation Systems. *Ind. Eng. Chem. Res.* **2004**, 43, 5904.
- (22) Luyben, W. L. 10 Schemes to Control Distillation Columns. *ISA J.* **1966**, July, 37.
- (23) Doukas, N.; Luyben, W. L. Economics of Alternative Distillation Configurations for the Separation of Ternary Mixtures. *Ind. Eng. Chem. Process Des. Dev.* **1978**, 17(3), 272.
- (24) Kim, J. K.; Wankat, P. C. Quaternary Distillation Systems with Less than N-1 Columns. *Ind. Eng. Chem. Res.* **2004**, 43, 3838.
- (25) Elaahi, A.; Luyben, W. L. Alternative Distillation Configurations for Energy Conservation in Four-Component Separations. *Ind. Eng. Chem. Process Des. Dev.* **1983**, 22, 80.

- (26) Luyben, W. L. *Distillation Design and Control Using Aspen Simulation*; Wiley and Sons, Inc.: New Jersey, 2006.
- (27) Smith, R.; Linnhoff, B. The Design of Separators in the Context of Overall Processes. *Trans. IChemE ChERD*, **1988**, 66, 195.

Chapter 8

Conclusions

The issue addressed in this thesis regards the energy saving in the retrofit and design of distillation plants. The research has been motivated by the continuous increasing of energy price that limits the industry competitiveness and it is ever becoming a critical issue in fulfilling sustainable development. Moreover Process Intensification is considered a significant tool to improve process performance by reducing the number of equipments in the plant.

Following this bottom line two approaches are considered. The former regards the analysis of existing plants built before the development of a more conscious energy employing. This type of analysis commonly called retrofit or process retrofitting, was done for two case studies both voted to the reduction in energy consumption. Different results and different tools were utilized to perform the retrofit analysis. In the first case study the addition of new equipment for the separation of light compounds from a crude stream was considered as a possible solution to reduce the heat duty of a crude distillation unit. The results shown that it is possible to reach different levels of energy saving depending on the type of flashing apparatus. In the second case a distillation column sequence was considered. The retrofit analysis was performed by employing recent technology modifications. For distillation systems, thermal coupling technique provides such an approach to retrofit the traditional simple column configurations through the elimination of condenser/s and/or reboiler/s. The configurations considered for the retrofit analysis were derived directly from the plant simple column sequence and a reduction of more than 20% of the energy cost was found with attention paid to the maximum usage of plant equipment. On this regard heat exchanger area and column sections were checked for their possible utilization in the new proposed configurations.

The second part of the thesis was addressed to the design of new configurations for the separation of a four component mixture. First a set of heuristic rules was considered for the selection of the best simple column sequence. The results obtained are compared with the rigorous calculation of the TAC index. Differences between the methodologies are used to understand, at the same time, the limits and the usefulness of the application of heuristic rules. From the selected simple column sequences, considering different composition cases, the possibility to use a hybrid structure composed by a simple column and a divided wall column was evaluated. To this scope a short-cut model for the divided wall columns (DWC) was considered and utilizing the Underwood-Fenske Gilliland method the feasible design space was identified and explored for the minimum TAC value configuration. The design parameters obtained for the selected configuration are then used in an Aspen rigorous model. The comparison between the simple column configuration and the new hybrid configuration underlines in which composition cases the DWC can outperform the simple column performances.

Finally, according to Process Intensification principles, a method to identify a column configurations subspace was presented. This subspace includes all the possible distillation column configurations with less than $(n-1)$ columns and is proved to be cost effective in a few composition cases or in particular circumstances of plant space limitations. The proposed method allows to connect the subspace of column configuration with less than $(n-1)$ columns to the simple column sequences from which are derived. In this thesis the general method was presented and applied according also to a case study that proves the possibility for the energy reduction.

Appendix A

A.1 Distillation Sizing and Cost Evaluation

From the number of theoretical trays obtained from the simulation package Aspen Plus or from short-cut methods it is possible to calculate the real or effective number of stages using empirical evaluation of the overall column efficiency related to the internal vapor and liquid flow rate, the relative volatility and physical properties. For Sieve trays the following simplified equation was used:

$$\log(E_0) = 1.67 - 0.25 \log(\overline{\mu\alpha}) + 0.30 \log\left(\frac{\overline{L}}{\overline{V}}\right) + 0.30(h_w) \quad (\text{A.1})$$

$$N_{real} = \frac{N_{theoretical}}{E_0} \quad (\text{A.2})$$

The column height can be calculated for a fixed tray spacing and vapor disengagement value:

$$H = (N_{real} - 1)h_{ts} + h_{vd} \quad (\text{A.3})$$

From the column height value it is possible to evaluate the column shell cost considering carbon steel construction:

$$C_S = \left(\frac{M \& S}{280}\right) 937.61 D^{1.066} H^{0.802} \quad (\text{A.4})$$

If the operating pressure is higher than 345 kPa a correction factor is applied to eq. A.4.

$$P_{CF} = \left(1 + 1.45 \cdot 10^{-4} (P - 345)\right) \quad (\text{A.5})$$

The tray installation cost evaluation can be obtained from the relation:

$$C_T = \left(\frac{M \& S}{280}\right) 97.24 D^{1.55} h \quad (\text{A.6})$$

The total column cost is the sum of the column shell and tray cost.

A.2 Heat exchanger cost evaluation

The heat exchanger cost relations are usually function of the surface area evaluated with the well known design formula:

$$A = \frac{Q}{U_d \Delta T_{LM}} \quad (\text{A.7})$$

The cost formula was developed for shell and tube, floating head and carbon steel construction, design pressure up to 1034.2 kPa, and is valid in the indicated area range.

$$C_{HE} = \left(M \& S / 280 \right) (474.67) A^{0.65} \quad (\text{A.8})$$

$$A(m^2); 18.6 < A < 464.5 \quad (\text{A.9})$$

A.3 Total Annual Cost

The total annual cost is the sum of the capital and operational costs. The former are evaluated as a sum of the column shell, tray and heat exchanger costs considering a plant lifetime of 10 years. The latter are obtained by considering the utility costs already reported in the text and assuming an operating hours of 8000 hours/year.

$$TAC = \frac{\text{Capital Cost}}{\text{Lifetime}} + \text{Annual Operating Cost} \quad (\text{A.10})$$

A.4 Notation

A = heat transfer area [m²]

C_S = shell column cost [\$]

C_T = column tray installation cost [\$]

D = column diameter [m]

E₀ = overall column efficiency

h = tray stack height [m]

h_{TS} = tray spacing [m]

h_{VD} = vapor disengagement height [m]

h_w = weir height [m]

H = column height [m]

\bar{L} = molar liquid flow rate [kmol/h]

M&S = Marshall & Shift index

N_{real} = actual number of trays

$N_{\text{theoretical}}$ = number of ideal stages

P = operating column pressure [kPa]

P_{CF} = pressure correcting factor

Q = exchanged heat [kJ/h]

TAC = total annual cost [\$]

U_d = overall heat transfer coefficient [kJ/h m² K]

\bar{V} = molar vapor flow rate [kmol/h]

$\bar{\alpha}$ = mean relative volatility

μ = average viscosity of the feed [cP]

ΔT_{LM} = logarithm mean temperature difference [K]

Appendix B

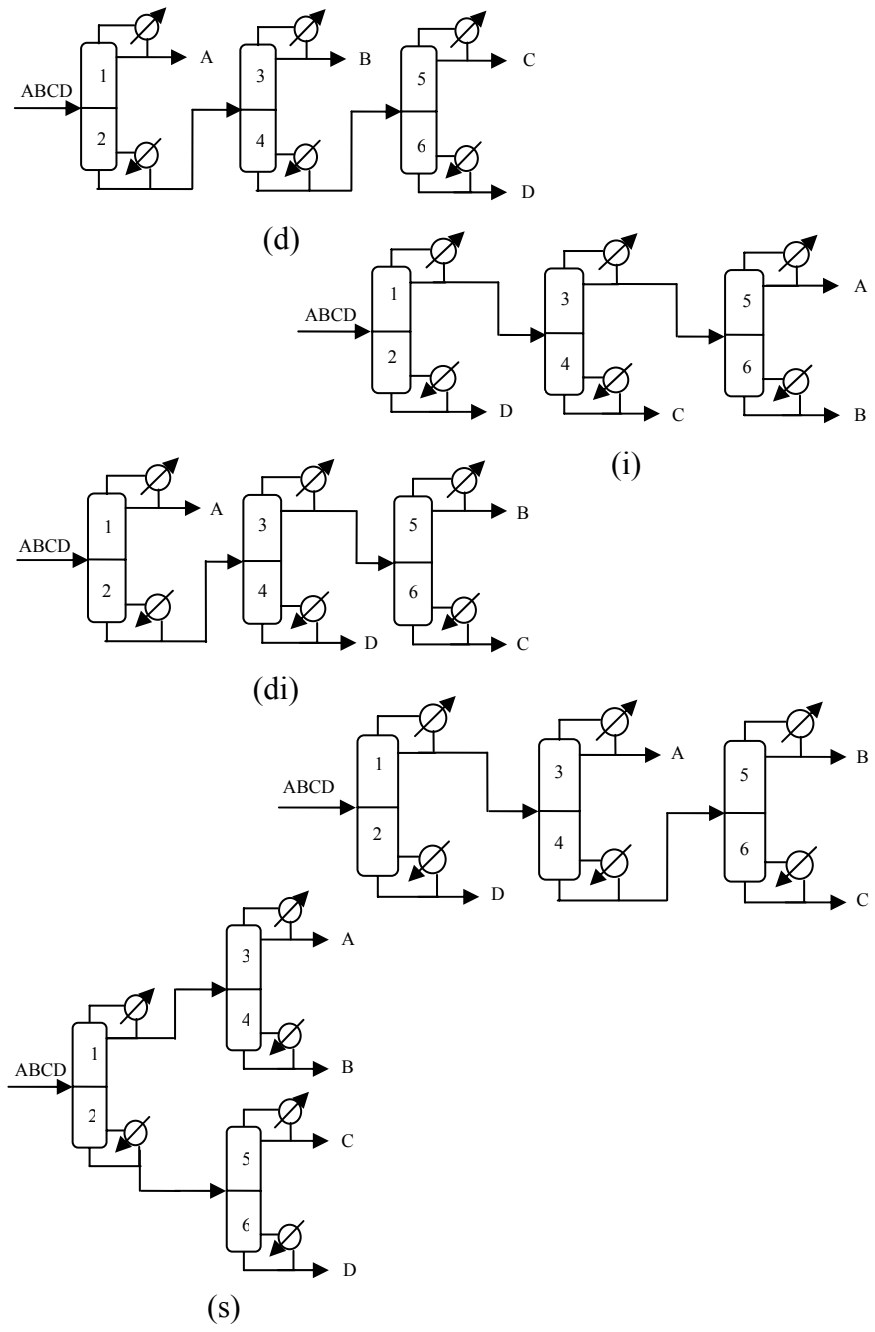
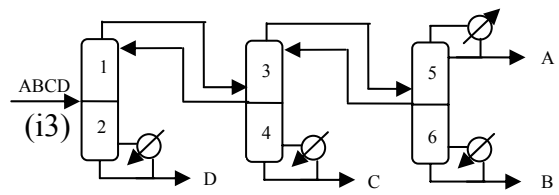
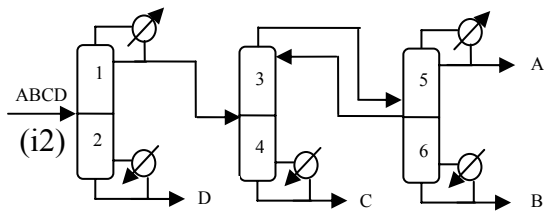
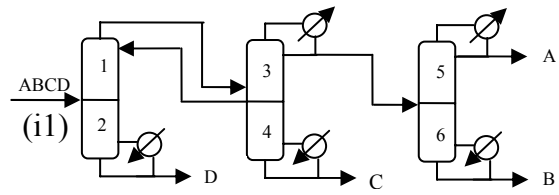
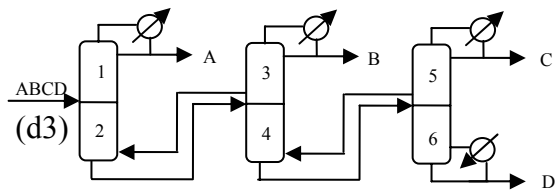
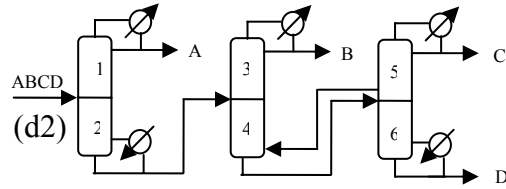
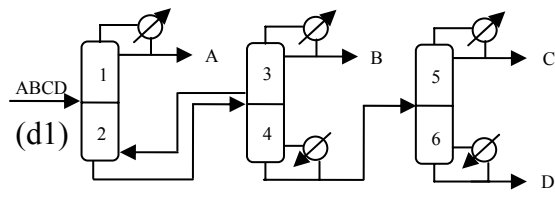
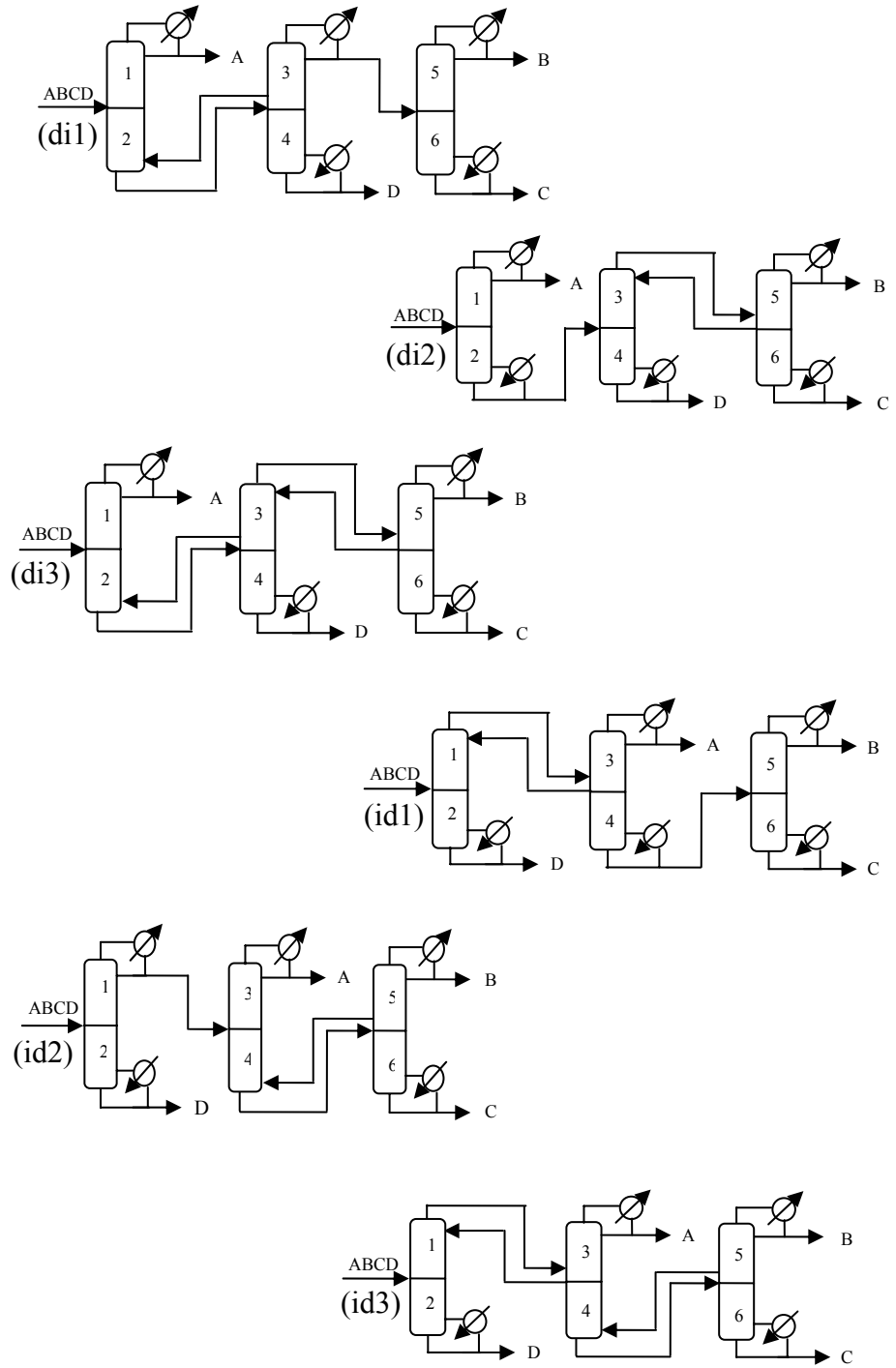

Figure B1: Simple column configurations for a four component mixture.





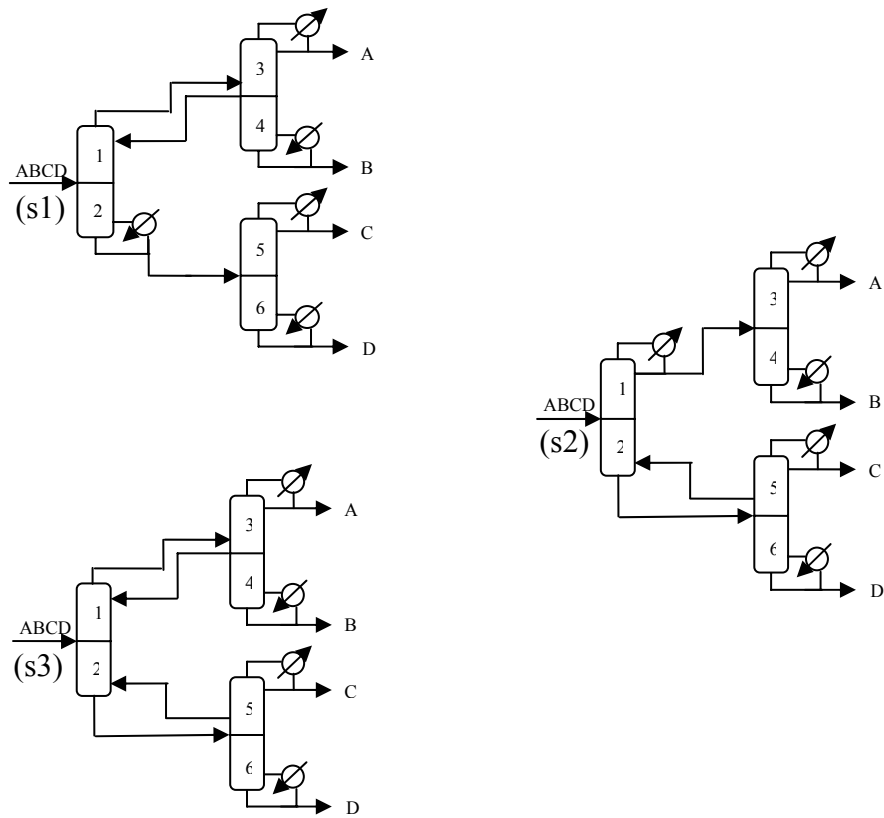
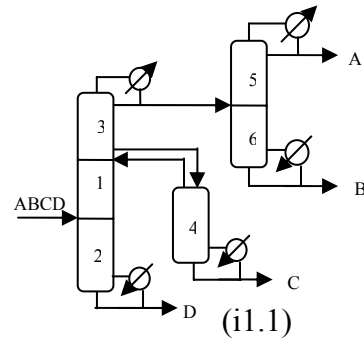
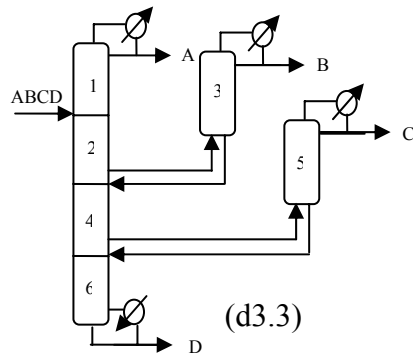
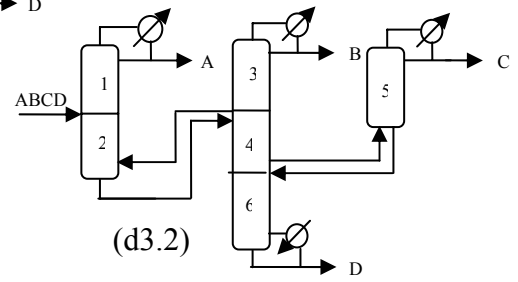
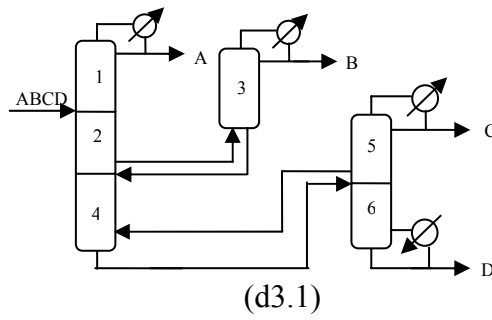
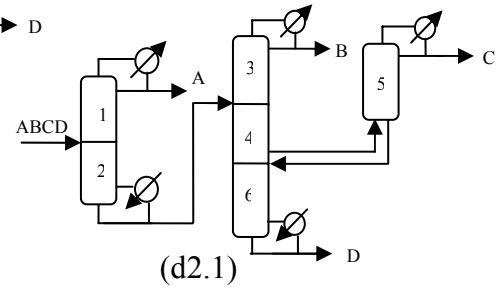
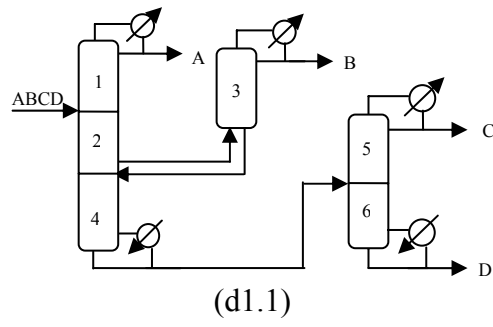
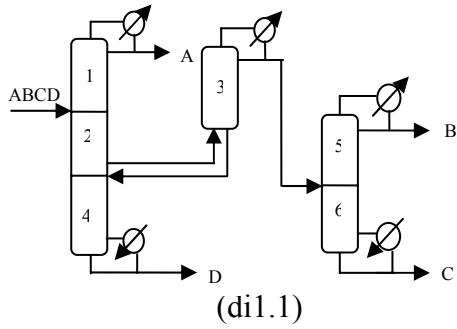
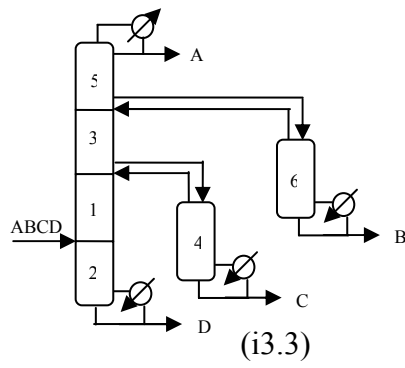
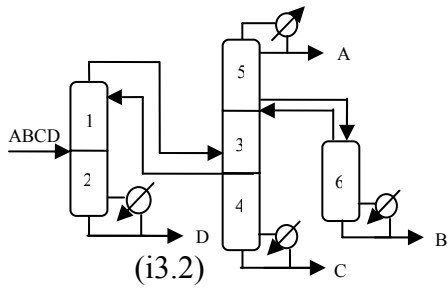
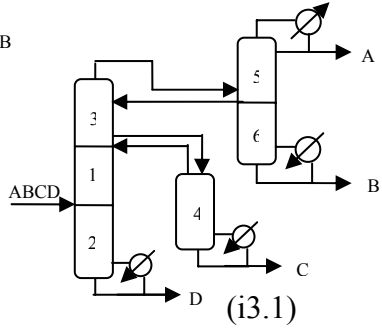
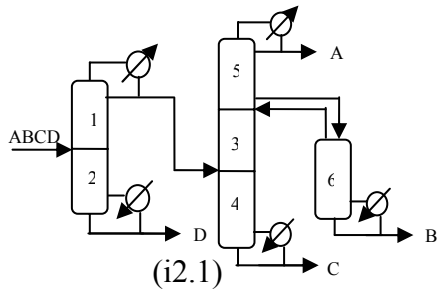
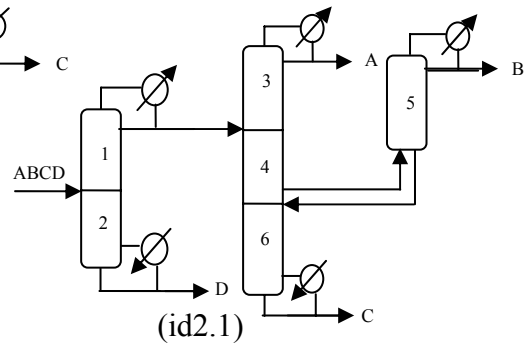
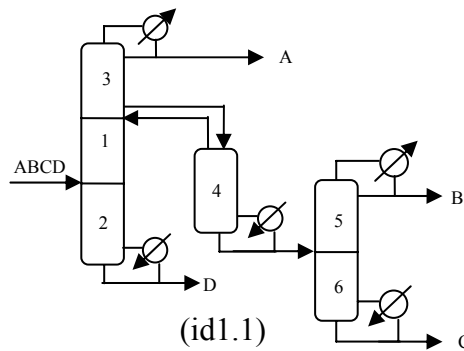
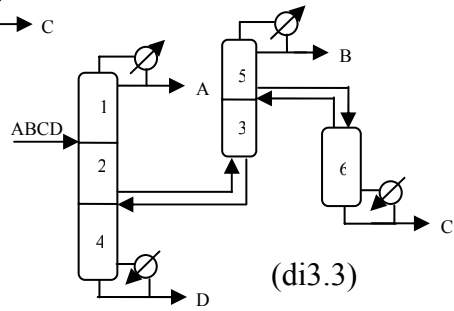
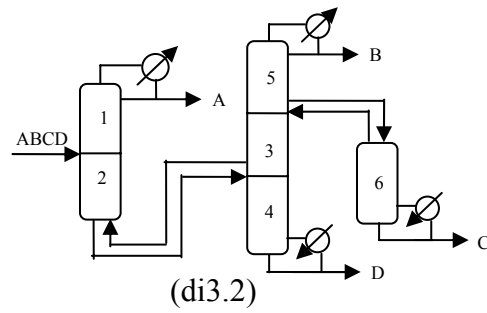
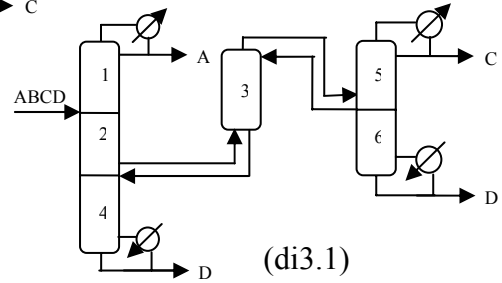
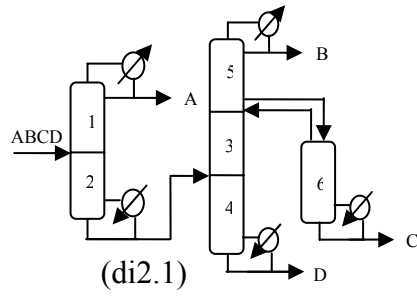
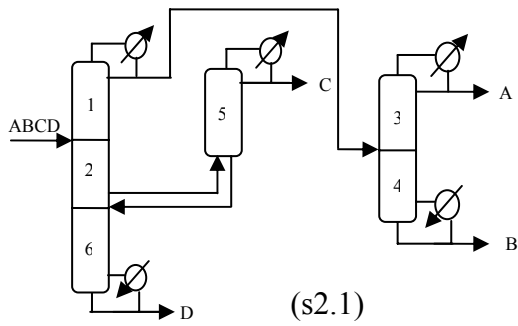
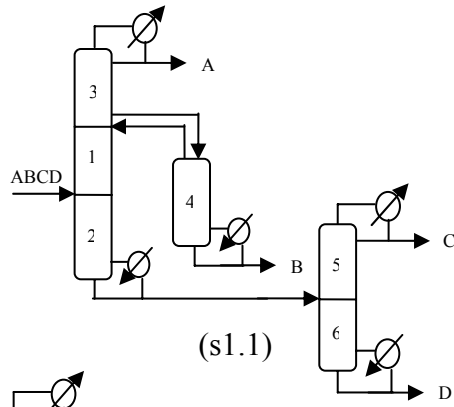
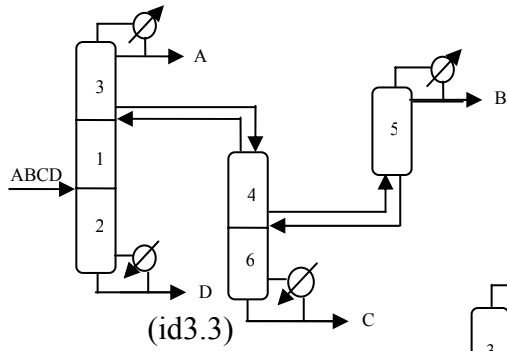
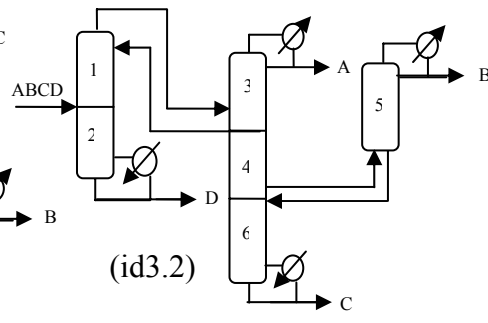
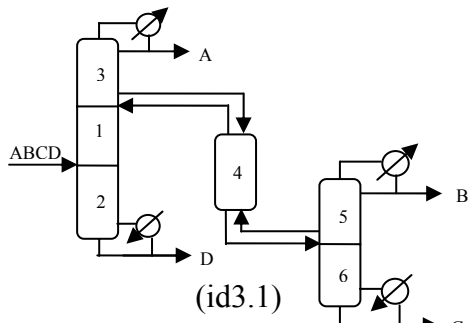

Figure B2: Thermally coupled distillation sequences for a four component mixture.









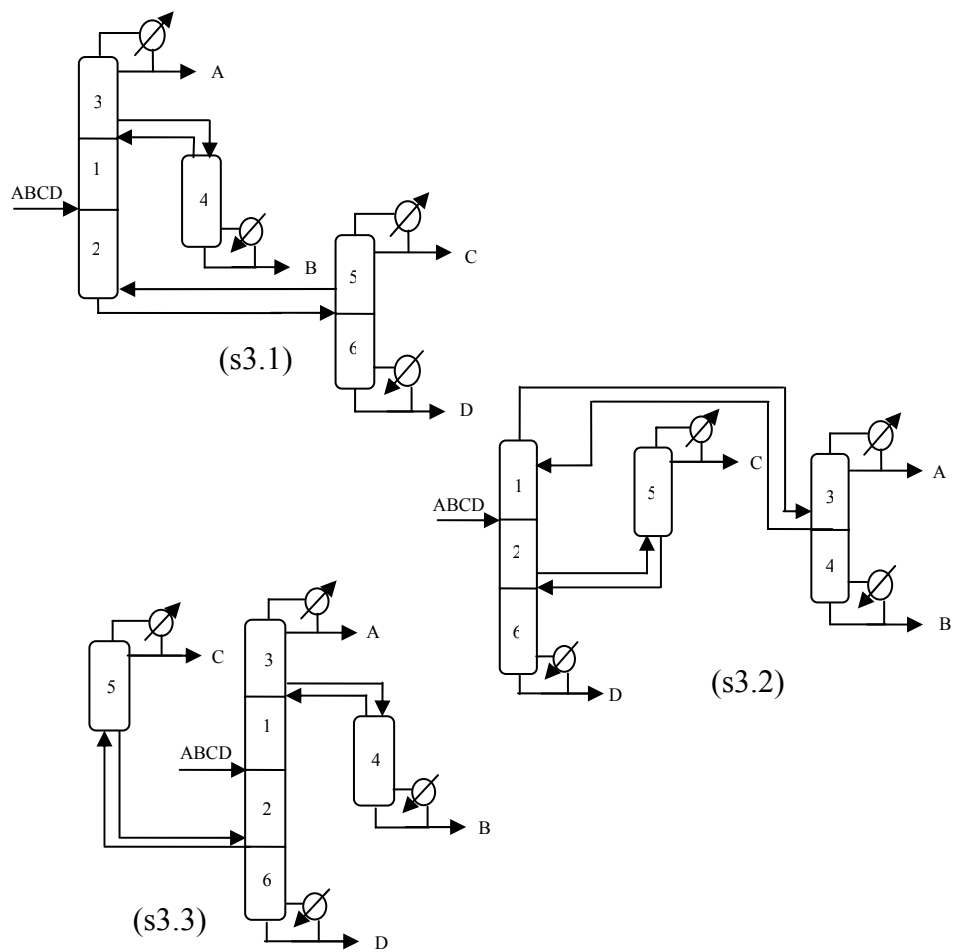
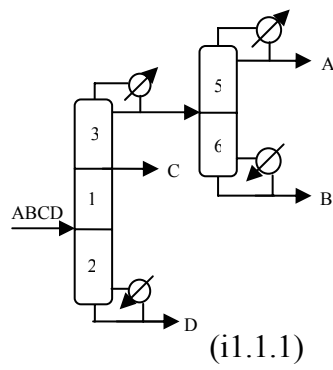
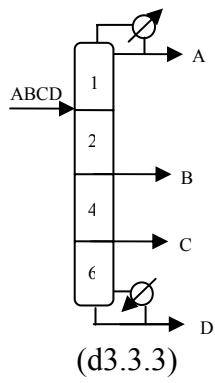
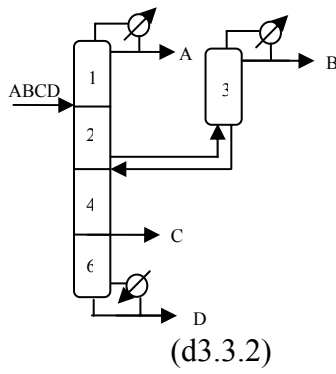
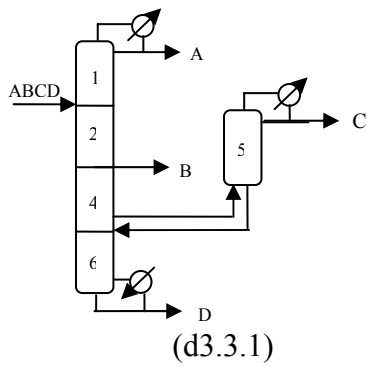
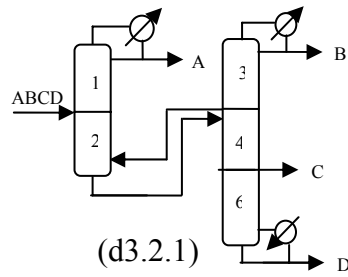
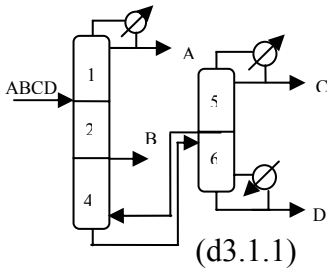
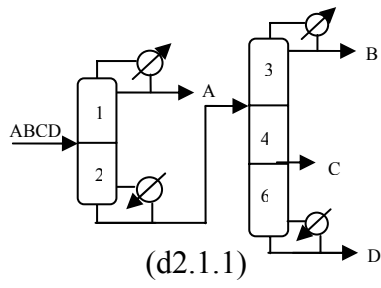
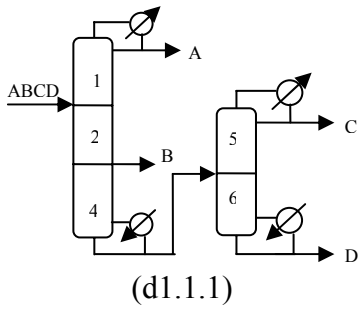
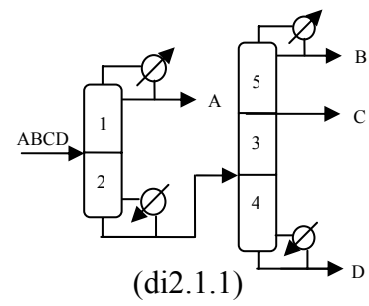
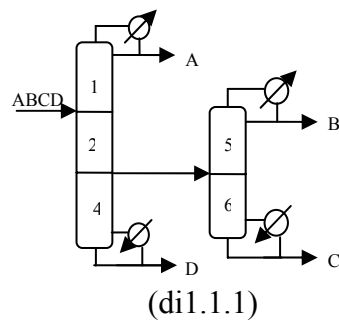
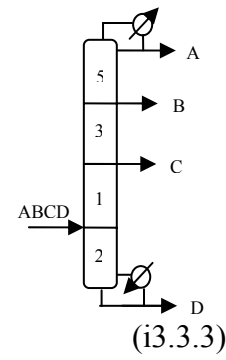
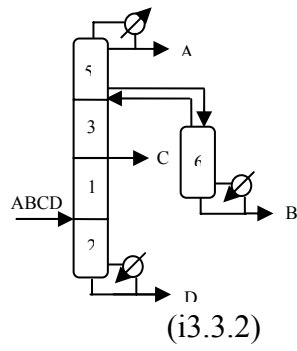
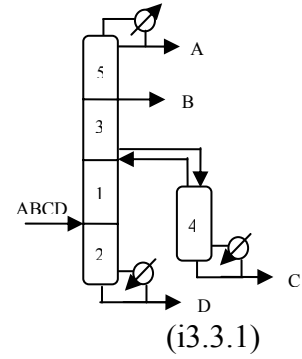
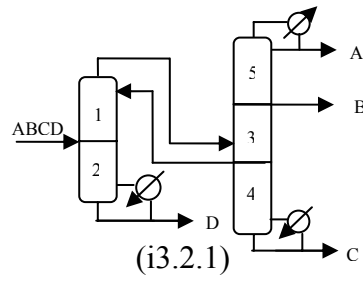
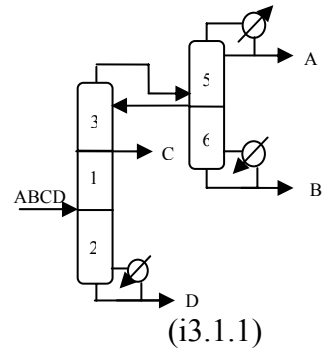
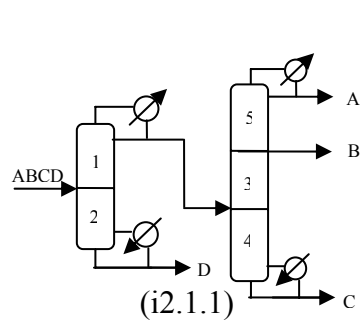
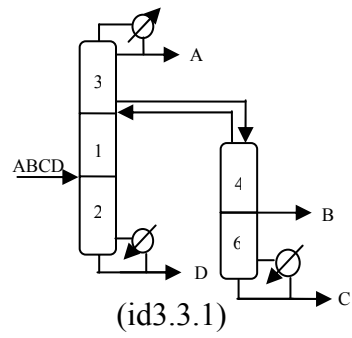
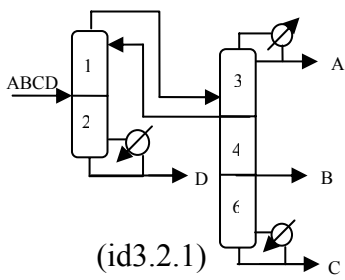
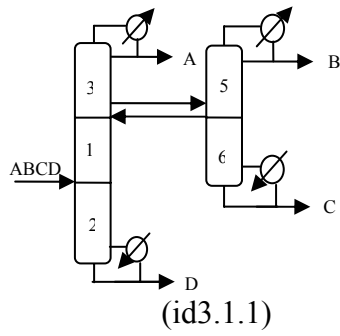
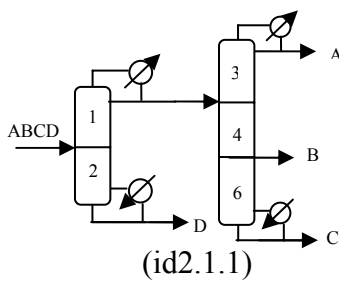
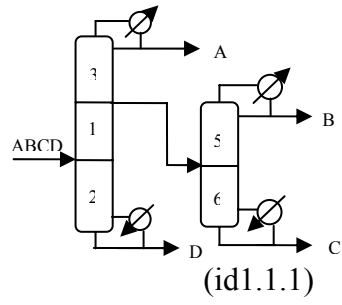
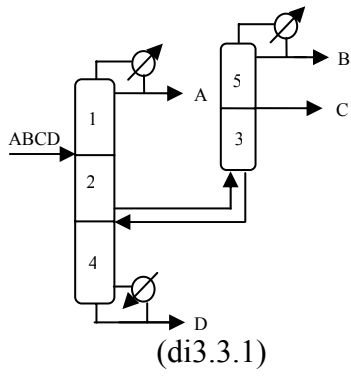
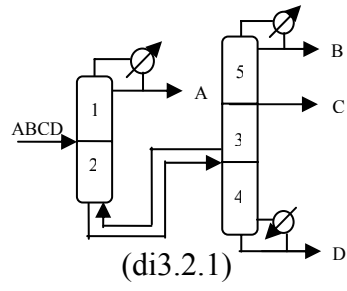
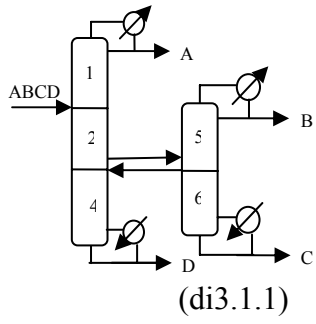

Figure B3: Thermodynamically equivalent configuration for a four components mixture.







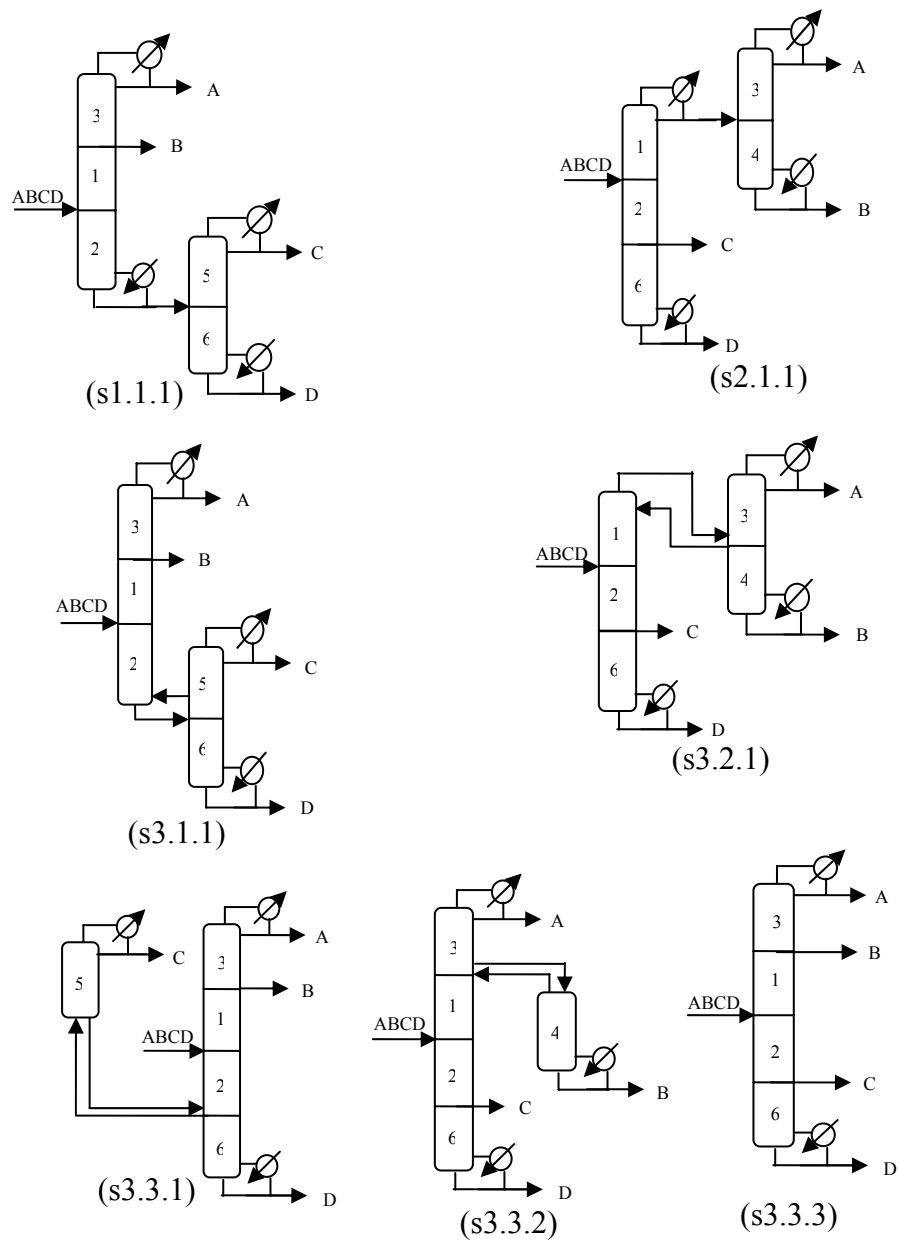

Figure B4: less than $n-1$ columns configurations for a four component separation.

$$\begin{array}{ccc}
 \begin{array}{l}
 d \left\{ \begin{array}{l}
 d1 \rightarrow d1.1 \rightarrow d1.1.1 \\
 d2 \rightarrow d2.1 \rightarrow d2.1.1 \\
 d3 \left\{ \begin{array}{l}
 d3.1 \rightarrow d3.1.1 \\
 d3.2 \rightarrow d3.2.1 \\
 d3.3 \left\{ \begin{array}{l}
 d3.3.1 \\
 d3.3.2 \\
 d3.3.3
 \end{array} \right.
 \end{array} \right.
 \end{array}
 \end{array} &
 \begin{array}{l}
 i \left\{ \begin{array}{l}
 i1 \rightarrow i1.1 \rightarrow i1.1.1 \\
 i2 \rightarrow i2.1 \rightarrow i2.1.1 \\
 i3 \left\{ \begin{array}{l}
 i3.1 \rightarrow i3.1.1 \\
 i3.2 \rightarrow i3.2.1 \\
 i3.3 \left\{ \begin{array}{l}
 i3.3.1 \\
 i3.3.2 \\
 i3.3.3
 \end{array} \right.
 \end{array} \right.
 \end{array}
 \end{array} &
 \begin{array}{l}
 s \left\{ \begin{array}{l}
 s1 \rightarrow s1.1 \rightarrow s1.1.1 \\
 s2 \rightarrow s2.1 \rightarrow s2.1.1 \\
 s3 \left\{ \begin{array}{l}
 s3.1 \rightarrow s3.1.1 \\
 s3.2 \rightarrow s3.2.1 \\
 s3.3 \left\{ \begin{array}{l}
 s3.3.1 \\
 s3.3.2 \\
 s3.3.3
 \end{array} \right.
 \end{array} \right.
 \end{array}
 \end{array} \\
 \\
 \begin{array}{l}
 di \left\{ \begin{array}{l}
 di1 \rightarrow di1.1 \rightarrow di1.1.1 \\
 di2 \rightarrow di2.1 \rightarrow di2.1.1 \\
 di3 \left\{ \begin{array}{l}
 di3.1 \rightarrow di3.1.1 \\
 di3.2 \rightarrow di3.2.1 \\
 di3.3 \rightarrow di3.3.1
 \end{array} \right.
 \end{array}
 \end{array} &
 \begin{array}{l}
 id \left\{ \begin{array}{l}
 id1 \rightarrow id1.1 \rightarrow id1.1.1 \\
 id2 \rightarrow id2.1 \rightarrow id2.1.1 \\
 id3 \left\{ \begin{array}{l}
 id3.1 \rightarrow id3.1.1 \\
 id3.2 \rightarrow id3.2.1 \\
 id3.3 \rightarrow id3.3.1
 \end{array} \right.
 \end{array}
 \end{array}
 \end{array}
 \end{array}$$

Table B1: Summarizing table.