

Homma, T., Ochiai, M. and Takahashi, M.
Osaka J. Math.
17 (1980), 625-648

AN ALGORITHM FOR RECOGNIZING S^3 IN 3-MANIFOLDS WITH HEEGAARD SPLITTINGS OF GENUS TWO

TATSUO HOMMA, MITSUYUKI OCHIAI AND MOTO-O TAKAHASHI

(Received September 3, 1979)

1. Introduction

At the beginning of the century Poincaré made a start to study the problem to determine whether a 3-manifold is the 3-sphere or not. He kept observation on the algebraic property of S^3 and conjectured that every homotopy 3-sphere is the 3-sphere. But the question is extremely difficult and still remains open. Thus we shall be concerned mainly with another and rather geometric approach: how can we recognize a Heegaard diagram of S^3 ? In this direction the first basic work was done by J.H.C. Whitehead [9], and later, as an algorithm for recognizing S^3 in 3-manifolds, Volodin-Kuznetsov-Fomenko [7] gave Algorithm (A), which is differently formulated from Whitehead's algorithm but equivalent to it, and checked the efficiency of their algorithm by a trial calculation on the computer BESM 6 but they did not succeed in verifying it mathematically. The assertion of Algorithm (A) is that all Heegaard diagrams of S^3 , other than the canonical one, always contain at least one reducible part, (that is, a distinguished domain). Recently Birman states in [2] that "nobody has succeeded in verifying such an assertion between 1935 and 1977, or producing a counterexample". But we will prove the following special case;

Main Theorem. *Every Heegaard diagram of genus two of the 3-sphere S^3 , other than the canonical one, always contains at least one reducible part.*

We remark that the second author produced in [5] that a counterexample to the assertion in the case when the Heegaard genus is four and has proved in [4] that certain Heegaard diagrams of 3-manifolds obtained by non-trivial Dehn surgery along any non-trivial 2-bridge knots have no reducible parts (and so such 3-manifolds are not the 3-sphere by the above theorem). Moreover we remark that recently Morikawa [11] gives a counterexample to the assertion in the case when the Heegaard genus is three.

We work in the piecewise linear category throughout this paper. By $N(Y, X)$ we shall denote a regular neighborhood of a sub-polyhedron Y in a

polyhedron X . S^n , D^n denote n -sphere, n -disk, respectively. Closure, interior, boundary over one symbol \cdot are denoted by $cl(\cdot)$, $In(\cdot)$, $\partial(\cdot)$.

2. Waves and band sums

A Heegaard splitting of a 3-manifold M is a representation of M as $V \cup W$, where V and W are homeomorphic handlebodies of some fixed genus n and $V \cap W = \partial V = \partial W = F$, a Heegaard surface.

A properly embedded disk D in a handlebody X of genus n is called a meridian-disk of X if $cl(X - N(D, X))$ is a handlebody of genus $n - 1$, and a collection of mutually disjoint n meridian-disks, D_1, \dots, D_n in X is called a complete system of meridian-disks of X if $cl(X - \bigcup_{i=1}^n N(D_i, X))$ is a 3-disk. Furthermore a collection of mutually disjoint circles on the boundary of X is called a complete system of meridians of X (or ∂X) if it bounds a complete system of meridian-disks of X .

Let $\{v\} = \{v_1, \dots, v_n\}$ and $\{w\} = \{w_1, \dots, w_n\}$ be complete systems of meridians of V and W , respectively. The triplet $(F; v, w)$ is called a Heegaard diagram of the splitting $(V, W; F)$. Hereafter we assume that v_i (resp. w_j) intersects w_j (resp. v_i) transversely whenever $v_i \cap w_j \neq \emptyset$.

Two Heegaard diagrams $(F; v, w)$ and $(F'; v', w')$ of Heegaard splittings $(V, W; F)$ and $(V', W'; F')$, respectively, are *isomorphic* if there is a homeomorphism h from F on F' such that $h(v) = v'$ and $h(w) = w'$. It will be noticed that if $(F; v, w)$ is isomorphic to $(F'; v', w')$ then $(V, W; F)$ is equivalent to $(V', W'; F')$, that is, there is a homeomorphism H from M to M' such that $H(V) = V'$ and $H(W) = W'$, where M and M' are 3-manifolds given by $(V, W; F)$ and $(V', W'; F')$, respectively. (See §1 in in [7].) An isomorphism class of a Heegaard diagram of a Heegaard splitting is also called a Heegaard diagram.

It is easily verified that the Heegaard diagram (1_n) given by Figure 1 is one of the 3-sphere S^3 . It is called the canonical Heegaard diagram of genus n of S^3 .

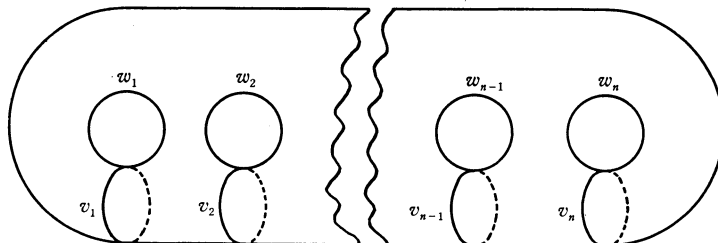

Figure 1. The canonical Heegaard diagram of S^3 of genus n , (1_n)

From now on, we assume that every Heegaard diagrams in the paper have the *non-empty intersecting* property (or simply NEI-property). That is in

every Heegaard diagram each meridian of one of the two complete systems of meridians intersects at least one meridian of the other. We remark that by Lemma 1 in [6] all Heegaard diagrams of homology 3-spheres have the NEI-property.

Given a Heegaard diagram $(F; v, w)$ of genus n with $v=v_1 \cup \dots \cup v_n$ and $w=w_1 \cup \dots \cup w_n$, we will define the set Q of domains for the diagram as follows; let N_i (resp. N'_j) be a regular neighborhood of v_i (resp. w_j) in F ($i, j=1, \dots, n$). Here we may assume that they are "sufficiently small" neighborhoods and so satisfy that $N_i \cap N_j = \emptyset$ and $N'_i \cap N'_j = \emptyset$ for any i and j ($i \neq j$). Let U be a connected component of $c(F - \bigcup_{i=1}^n N_i - \bigcup_{i=1}^n N'_i)$. Then Q is defined as a collection of such the domain U . Let U be a domain in Q . Each connected component of $\partial U \cap \partial N_k$ and $\partial U \cap \partial N'_k$ for any k ($k=1, \dots, n$) is called an *edge* of U or an *edge associated* with v_k or w_k . To avoid an orgy of notation in such definitions, we may assume hereafter that the set of domains Q is a collection of domains obtaining by cutting F along v and w , and that an edge of U is one of connected components of $\partial U \cap v_k$ and $\partial U \cap w_k$. We remark that every domain with exactly two edges is a 2-disk by the NEI-property.

A Heegaard diagram is said to be *normal* if the set of domains contains no domain whose boundary consists of exactly two edges. If such a domain exists in the set of domains, by the above remark it can be eliminated by an isotopy deformation on F of one of the two complete systems of meridians with respect to the other. As a result of applying this isotopy deformation to the diagram, we obtain again a new diagram of the same manifold. Applying a finite sequence of such isotopy deformations to a Heegaard diagram, at the final step we will obtain a normal Heegaard diagram. We call such a normal Heegaard diagram the *normalized* diagram of the original one. It will be noticed that by Proposition 1 in [6] any two normalized diagram of a Heegaard diagram are isomorphic. Hereafter we assume that all Heegaard diagrams in this paper are normal, unless otherwise specified.

Next we will define the concept of waves of Heegaard diagrams. From now on, we assume that all Heegaard diagrams are oriented, that is, in any Heegaard diagram $H=(F; v, w)$ the orientations of all meridians in v and w are supposed to be given. Let Q be the set of domains for H . A domain U in Q is called to be *distinguished* if among the edges that form its boundary there are two edges E_1 and E_2 belonging to a single meridian and their orientations agree in any circuit around the boundary of U . (See Figure 2.) The edges E_1 and E_2 are also said to be *distiguished*. A segment τ inside a distinguished domain joining interior points of the distinguished edges is called a *wave*. (See Figure 2.) Let y be the meridian containing the distinguished edges. Then the wave τ is said to be *associated with* y . It will be noticed that by Theorem 4.3.1 in

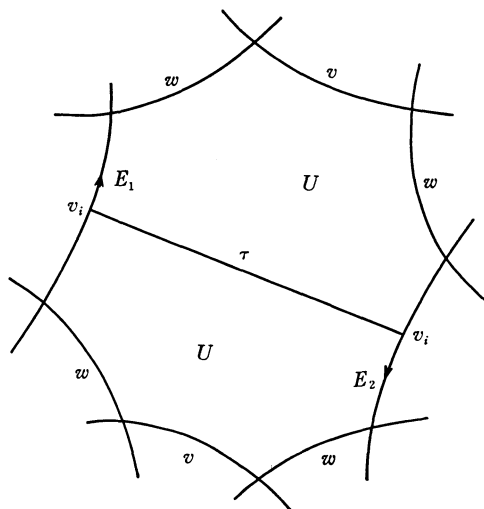
Figure 2. a wave τ in a domain U

[7] the existence of a wave in a Heegaard diagram of a 3-manifold permits us to simplify the diagram without changing its homeomorphic type. To explain such a simplifying procedure, we will define the concept of wave-moves of Heegaard diagrams as follows; let τ be a wave in a distinguished domain U , associated with some meridian y in v or w . Let us suppose that y is v_i in v , say v_1 . Let N be a regular neighborhood of $y \cup \tau$ in F . By the definition of waves, the boundary of N has three components. Let $y(\tau)$ be the component of ∂N which is not isotopic on F to any meridians in $v = v_1 \cup \dots \cup v_n$. In the case when Heegaard genus is greater than two, the additional condition is necessary; let $F(y)$ be the connected 2-manifold obtained by cutting F along v_2, \dots, v_n . (We note that $y = v_1$). It is clear that $y(\tau)$ is contained in $\text{Int}(F(y))$. Then it is necessary that $\text{Int}(F(y)) - y(\tau)$ is connected. Now $v(\tau) = y(\tau) \cup v_2 \cup \dots \cup v_n = v_1(\tau) \cup v_2 \cup \dots \cup v_n$ is also a complete system of meridians of F and then $(F; v(\tau), w)$ also gives a Heegaard diagrams. The Heegaard diagram $(F; v(\tau), w)$ may not be normal, and then there is a normal Heegaard diagram $(F; \bar{v}(\tau), w)$ which is the normalized diagram of it. Similarly $(F; v, w(\tau))$ and $(F; v, \bar{w}(\tau))$ are also defined, if y is w_i in w . Such the normal Heegaard diagrams are called the *wave-moves* of $(F; v, w)$ through v or w along τ . We note that the wave-moves of a Heegaard diagram are strictly simpler than the original one, that is, the intersections of $\bar{v}(\tau)$ and w or v and $\bar{w}(\tau)$ are less than those of v and w . Let $H = (F; v, w)$ and $H(\tau) = (F; \bar{v}(\tau), w)$ or $H(\tau) = (F; v, \bar{w}(\tau))$. Then by §4 in [7] we have;

Proposition 1. *The Heegaard diagrams H and $H(\tau)$ give the same Heegaard splitting and so they determine the same manifold.*

Next we introduce the concept of band sums in a complete system of meridians of F , $\{v\} = \{v_1, \dots, v_n\}$, where F is the boundary of a handlebody V of genus n . Choose any two meridians, v_i and v_j ($i \neq j$), and choose an arc α on F joining v_i and v_j , with the interior of α disjoint from v . Let N be a regular neighborhood of $v_i \cup \alpha \cup v_j$ on F and let v'_i be that component of ∂N which is not isotopic on F to either v_i and v_j . Then $v'_i = v_i \#_{\alpha} v_j$ is called the *band sum* of v_i and v_j along α . It is easy to see that v'_i also bounds a disk in V and that $v' = v_1 \cup \dots \cup v_{i-1} \cup v'_i \cup v_{i+1} \cup \dots \cup v_n$ is also a complete system of meridians of V and it is called a *band-move* of v (through v_i and v_j) along α .

Let $H = (F; v, w)$ be a Heegaard diagram. Then a Heegaard diagram $(F; v', w)$ (resp. $(F; v, w')$) is called a *band-move* of H through v (resp. w) along α (resp. α') if v' (resp. w') is a band-move of v (resp. w) along α (resp. α'). Let $H(\alpha) = (F; v', w)$ (resp. $(\alpha')H = (F; v, w')$) be a band-move of H through v (resp. w) along α (resp. α'). Then we have;

Lemma 1. *The following diagram commutes, that is, $(\alpha')(H(\alpha)) = ((\alpha')H)(\alpha)$;*

$$\begin{array}{ccc} H & \longrightarrow & H(\alpha) \\ \downarrow & & \downarrow \\ (\alpha')H & \longrightarrow & (\alpha')H(\alpha) \end{array}$$

Proof. Since the two band-moves are independant, the diagram commutes.

A Heegaard diagram $H(\hat{\alpha}) = (F; \hat{v}', w)$ (resp. $(\hat{\alpha}')H = (F; v, \hat{w}')$) is also called the *band-move* of H along α (resp. α') if $H(\hat{\alpha})$ (resp. $(\hat{\alpha}')H$) is the normalized diagram of $H(\alpha)$ (resp. $(\alpha')H$)

Lemma 2. *The following diagram commutes, that is, $(\hat{\alpha}')(H(\hat{\alpha})) = ((\hat{\alpha}')H)(\hat{\alpha})$;*

$$\begin{array}{ccccccc} H & \xrightarrow{\alpha} & H(\alpha) & \xrightarrow{n_1} & H(\hat{\alpha}) & \xrightarrow{\alpha'} & (\alpha')(H(\hat{\alpha})) \\ \alpha' \downarrow & & & & & & \downarrow n_2 \\ (\alpha')H & \xrightarrow{n_3} & (\hat{\alpha}')H & \xrightarrow{\alpha} & ((\hat{\alpha}')H)(\alpha) & \xrightarrow{n_4} & \alpha' \cdot H \cdot \alpha \end{array}$$

where n_1, n_2, n_3 , and n_4 are normalizations.

Proof. By Lemma 2 in [6], we may assume that the operation n_1 (resp. n_3) keeps w (resp. v) fixed. Thus the band sums in the above diagram are all well defined. It is clear that both $(\hat{\alpha}')(H(\hat{\alpha}))$ and $((\hat{\alpha}')H)(\hat{\alpha})$ are normalized diagrams of $(\alpha)H(\alpha)$ and so they are isomorphic by Proposition 1 in [6]. Then $\alpha' \cdot H \cdot \alpha$ represents the isomorphism class of those one. This completes the proof.

Next let H and H' be two Heegaard diagrams of a Heegaard splitting $(V, W; F)$ and let $H = (F; v, w)$ and $H' = (F; v', w')$.

Lemma 3. *There is a finite sequence of (normal) Heegaard diagrams, H_0, H_1, \dots, H_k , with $H_0=H$ and $H_k=H'$ such that H_i is a band-move of H_{i-1} ($i=1, \dots, k$).*

Proof. Since both v and v' are complete systems of meridians of V , by Zieschang [10] there is a finite sequence of complete systems of meridians of V , $v(0), v(1), \dots, v(m)$, with $v(0)=v$ and $v(m)=v'$ such that $v(i)$ is a band-move of $v(i-1)$ ($i=1, 2, \dots, m$). Thus there is a finite sequence of normal Heegaard diagrams, $(F; v(0), \hat{w}(0)), (F; v(1), \hat{w}(1)), \dots, (F; v(m), \hat{w}(m))$, with $H=(F; v(0), \hat{w}(0))$ such that $(F; v(i), \hat{w}(i))$ is a band-move of $(F; v(i-1), \hat{w}(i-1))$ ($i=1, 2, \dots, m$), where $\hat{w}(i)$ is isotopic on F to $\hat{w}(i-1)$. By Zieschang [10], there is a finite sequence of complete systems of meridians of W , $w(m, 0), w(m, 1), \dots, w(m, n)$, with $w(m, 0)=\hat{w}(m)$ and $w(m, n)=w'$ such that $w(m, i)$ is a band move of $w(m, i-1)$ ($i=1, 2, \dots, n$). Then there is a finite sequence of normal Heegaard diagrams, $(F; \hat{v}'(0), w(m, 0)), \dots, (F; \hat{v}'(n), w(m, n))$, with $(F; \hat{v}'(0), w(m, 0))=(F; v(m), \hat{w}(m))$ such that $(F; \hat{v}'(i), w(m, i))$ is a band move of $(F; \hat{v}'(i-1), w(m, i-1))$ ($i=1, 2, \dots, n$), where $\hat{v}'(i)$ is isotopic on F to $\hat{v}'(i-1)$. Now $(F; v', w')$ is isomorphic to $(F; \hat{v}'(n), w(m, n))=(F; \hat{v}'(n), w')$ by Lemma 2 in [6], because $(F; v', w')$ and $(F; \hat{v}'(n), w')$ are normal and $v'=v(m)=\hat{v}'(0)$ is isotopic on F to $\hat{v}'(n)$. This completes the proof.

3. Heegaard diagrams of genus two of S^3

In this section and later section, we consider only Heegaard splittings of genus two and so we omit the adjective “of genus two”. Let $(V, W; F)$ be a Heegaard splitting of a 3-manifold M and $(F; v, w)$ a (normal) Heegaard diagram with $v=v_1 \cup v_2$ and $w=w_1 \cup w_2$. Next we define Whitehead graphs of Heegaard diagrams; cutting F along two circles v_1 and v_2 , as a result we obtain a 2-sphere with four holes: $v_1^+, v_2^+, v_1^-, v_2^-$, where v_i generates v_i^+ and v_i^- ($i=1, 2$). Under this operation, both circles of w are cut up and they turn into a collection of arcs joining the holes. Let us suppose that these four holes are the vertices, and the arcs the edges of a graph. Thus we obtain a graph G_v . Similarly, we obtain G_w called the dual graph of G_v . It will be noticed that neither G_v nor G_w have an isolated vertex and a “trivial” loop edge, because Heegaard diagrams considered here have the NEI-property and are normal. The graphs G_v and G_w are called the *Whitehead graphs* (or simply *W-graphs*) of $(F; v, w)$. Then by Theorem 1 in [6] we have;

Lemma 4. *Every W-graph of Heegaard diagrams is isomorphic as planar graphs to one of the three graphs of type I, II, III, illustrated in Figure 3, where a, b, c , and d represent the numbers of “parallel” edges.*

Moreover by Corollary 1 in [6] we have;

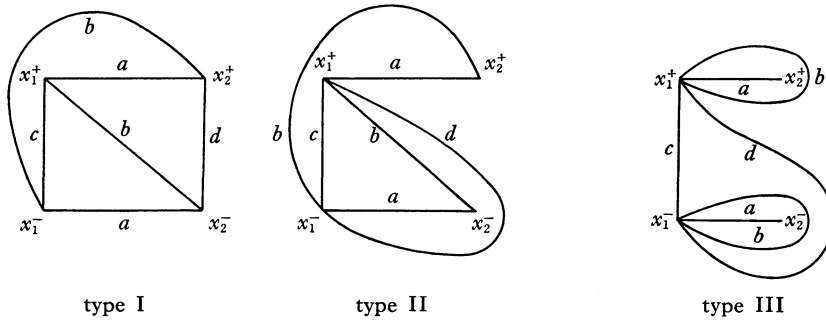

Figure 3. W -graphs, where $x_1^+ = v_1^+$ (resp. w_1^+), $x_1^- = v_1^-$ (resp. w_1^-), $x_2^+ = v_2^+$ (resp. w_2^+), and $x_2^- = v_2^-$ (resp. w_2^-).

Lemma 5. *There is an orientation-preserving involution T on F with six fixed points such that $T(v_i) = v_i$ and $T(w_i) = w_i$ and each of $T(v_i)$ and $T(w_i)$ has exactly two fixed points. In particular, for every domain U in the set Q of domains of $(F; v, w)$, $T(U)$ is also contained in Q .*

We remark that the orientation of an edge E in ∂U is opposite to $T(E)$ in ∂U .

A domain U in Q is called a *major domain*, if ∂U consists of more than four edges. We note that all W -graphs have no isolated vertices and so ∂U consists of even numbers of edges and the set of domains of any Heegaard diagram contains at least one major domain because the two meridians of a complete system of meridians are not isotopic on F .

To simplify later arguments, we choose a special type of waves and bands. Let α be a band joining x_1 and x_2 , where either $x_1 \cup x_2 = v$ or $x_1 \cup x_2 = w$, and let τ be a wave associated with some meridian y in either v or w . Let (α) (resp. (τ)) be the relative isotopy class of $(\alpha, \partial\alpha)$ (resp. $(\tau, \partial\tau)$) in $(F, x_1 \cup x_2)$ (resp. (F, y)). Then there is a band α' in (α) joining x_1 and x_2 such that it has the least intersections with $(v \cup w) - (x_1 \cup x_2)$ among the bands in (α) , and there is also a wave τ' in (τ) , associated with y , that is contained in some major domain in Q . It is easy to see that $x_1 \# x_2$ is isotopic on F to $x_1 \# x_2$ and that $y(\tau)$ is isotopic on F to $y(\tau')$. Such a band or a wave is called the *simplest representative* of the original one. Moreover in the case when α is disjoint from $(v \cup w) - (x_1 \cup x_2)$, the simplest representative α' can be found to be contained in some major domain in Q . From now on, we consider only the simplest representatives, whenever bands and waves are considered.

Let us consider some special band in a major domain. Let α be a band joining x_1 and x_2 in a major domain U in Q and let E and E' be two edges in ∂U , whose interior points are joined by the band α . Then α is called a *parallel band* if one of connected components of $cl(\partial U - E \cup E')$ consists of one edge in ∂U . We note that if α is not parallel and joins v_1 and v_2 (resp. w_1 and w_2),

then it intersects w (resp. v) or there are more than two edges in each connected component of $cl(\partial U - E \cup E')$. In this context we have;

Lemma 6. *Let $H=(F; v, w)$ be a normal Heegaard diagram, let α be a non-parallel band joining v_1 and v_2 , and let $v_3=v_1 \#_{\alpha} v_2$ and either $v'=v_1 \cup v_3$ or $v'=v_2 \cup v_3$. Then $(F; v', w)$ is a normal Heegaard diagram and has a wave τ associated with v such that $(F; \bar{v}'(\tau), w)$ is isomorphic to H , where $(F; \bar{v}'(\tau), w)$ is the wave-move of $(F; v', w)$ along τ .*

Proof. Let us suppose that $\alpha \cap w \neq \emptyset$. Then there are two arcs k_1 and k_2 in α , with $Int(k_1) \cap Int(k_2) = \emptyset$ and $k_i \cap \partial \alpha \neq \emptyset$ ($i=1, 2$), and there are two major domains U_1 and U_2 which contain k_1 and k_2 respectively, with $k_i \cap \partial U_i = \partial k_i = A_i \cup B_i$ ($i=1, 2$), where A_i and B_i are two boundary points of k_i . We may assume that point A_i lies on an edge E_i in ∂U_i and v_i and that the point B_i lies on an edge E'_i in ∂U_i and w . Let N be a regular neighborhood of $v_1 \cup \alpha \cup v_2$ in F with $v_3 \subset \partial N$. Since H is normal and the band α is the simplest representative with $\alpha \cap w \neq \emptyset$, $(F; v', w)$ is also normal. Let $\tau_i = U_i \cap N \cap \partial N(E'_i, F)$. (See Figure 4.1 and 4.2.) Then τ_i is a wave associated with v_3 in the Heegaard diagram $(F; v_i \cup v_3, w) = H'$ such that H is isomorphic to $H'(\tau_i)$ ($i=1, 2$), where $H'(\tau_i)$ is the wave-move of H' along τ_i . Next if $\alpha \cap w = \emptyset$, then there exists a major domain U such that it contains α and that each of connected components of $cl(\partial U - E_1 \cup E_2)$ consists of more than two edge. Thus $(F; v', w)$ is also normal. (See Figure 5.) Let $\tau = U \cap N \cap \partial N(E_1, F)$. Then τ is a wave associated with v_3 in the Heegaard diagram H' , defined as above, and H is isomorphic to $H'(\tau)$, where $H'(\tau)$ is the wave-move of H' along τ . The proof is complete.

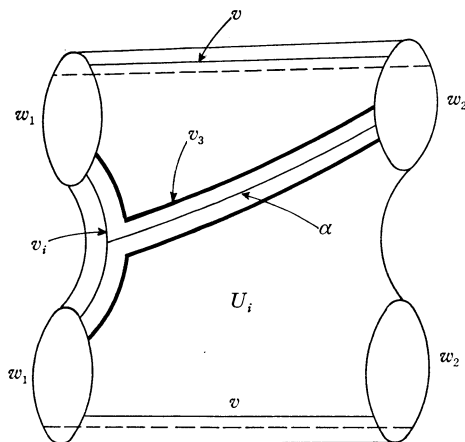

Figure 4.1

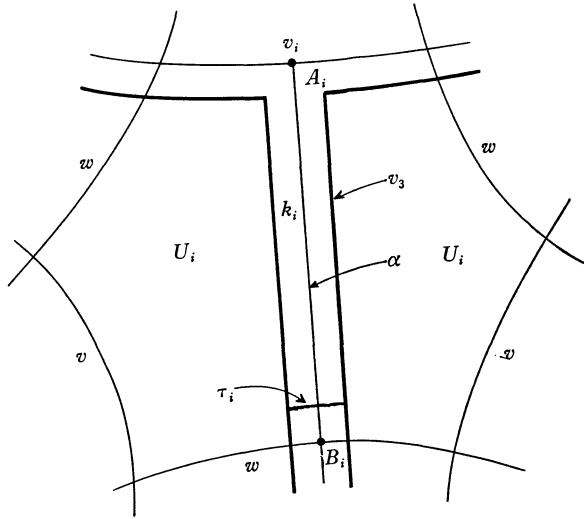

Figure 4.2

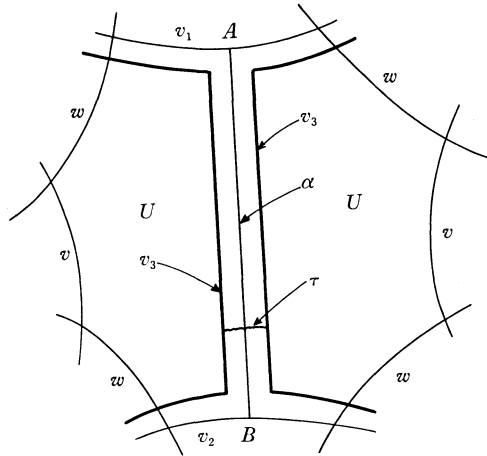

Figure 5.

We remark that in the above definition and proof, to avoid complexity, the set of domains \underline{Q} is thought of as the collection of “domains” obtained by cutting F along v and w and that we adopt this abbreviation throughout the paper. It will be noticed that the same result as Lemma 6 holds also in the case when the band α joins w_1 and w_2 .

Next we are interested in a relation between a wave and a parallel band in the same major domain. Let τ' be a wave associated with v_1 and let α be a parallel band joining v_1 and v_2 and let $v_3 = v_1 \#_{\alpha} v_2$. Moreover let $H(\tau')$ be the wave-move of $H = (F; v, w)$ along τ' , let $H(\alpha, i)$ be the normalized diagram of

$(F; v_i \cup v_3, w)$ ($i=1, 2$), and let $H(\alpha, 1)(\tau')$ be the wave move of $H(\alpha, 1)$ along τ' . We remark that H is normal and has NEI-property and so τ' is also a wave associated with v_1 in $H(\alpha, 1)$.

Lemma 7. *The circle v_3 is isotopic on F to $v_1(\tau')$. In particular, $H(\tau)$ is isomorphic either to $H(\alpha, 2)$ or $H(\alpha, 1)(\tau')$.*

Proof. Let G_v be a W -graph of H , obtained by cutting F along v . Since the wave τ' is associated with v_1 , the graph G_v is type III. (See Figure 6.) Since the band α is parallel, it is contained in some major domain U and join v_1^+ and v_2^+ or v_1^- and v_2^- in U . (See Figure 6.) Let τ'' be another wave associated with v_1 . As illustrated in Figure 6, the circle $v_1(\tau')$ is isotopic on F to the circle $v_1(\tau'')$. Thus the wave τ' is the wave illustrated in Figure 6. It is clear that \hat{v}_3 is isotopic on F to $v_1(\tau')$. This establishes the first assertion. From this the second assertion follows.

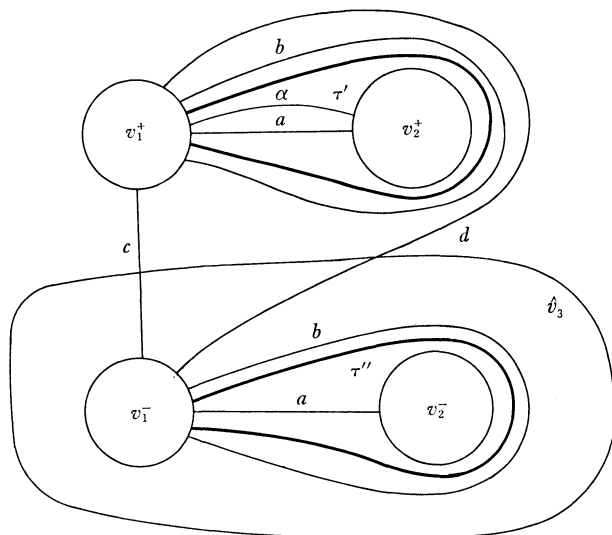

Figure 6.

As a trivial application of Lemma 7, we have;

Lemma 8. *Given a wave τ associated with v_1 , there is some (parallel) band α joining v_1 and v_2 such that $v_1 \#_{\alpha} v_2$ is isotopic on F to $v_1(\tau)$.*

It will be noticed that the band given by Lemma 8 can be easily found in the major domain containing the wave as illustrated in Figure 6.

4. Main Theorem and concluding remarks

Let $H=(F; v, w)$ be a Heegaard diagram of S^3 other than the canonical

one (1_2) and let G be a W -graph of H , with edge-parameters, a, b, c , and d . (See Figure 3.)

Lemma 9. *One of a and b is not zero, and one of c and d is not zero.*

Proof. If both a and b are zero, then G is not connected and so H must be isomorphic to (1_2) . Thus one of a and b is not zero. Next if both c and d are zero, then two cases happen;

Case (1): G is a graph of type III; then there exists a meridian v_3 on F disjoint from v and w , but it is impossible since H is a Heegaard diagram of S^3 . (See Proposition 2 in [6] in detail.)

Case (2): G is a graph of type I or II; let G_v (resp. G_w) be a W -graph of H along v (resp. w). If $G=G_v$, then there exists a meridian v_4 on F , disjoint from v , such that it transversely intersects each of the meridians in w at even number of points, but then the first homology group $H_1(S^3, Z)$ of S^3 can not vanish, contradiction. (See Proposition 2 in [6].) Thus we assume that $G=G_w$. But the similar argument as above leads the same contradiction. The proof is complete.

Now we will introduce a new concept of Heegaard diagrams of S^3 . Let H be a Heegaard diagram of S^3 other than (1_2) . Then H is said to be *reducible* if there is a finite sequence of (normal) Heegaard diagrams, H_n, \dots, H_0 , with $H_n=H$ and $H_0=(1_2)$, such that H_{i-1} is a wave-move of H_i ($i=1, 2, \dots, n$). Then easily we have the following lemma;

Lemma 10. *Let H' be a band-move of (1_2) along a band. Then H' is reducible.*

Moreover we have the following important fact;

Main Lemma 11. *Let H be an arbitrary reducible Heegaard diagram of S^3 and H' a band-move of H along a band α . Then H' is also reducible or isomorphic to (1_2) .*

Proof. We make the following induction statement;

$P(k)$: let H be (k) -reducible, that is, there is a finite sequence of (normal) Heegaard diagrams, H_k, \dots, H_0 , with $H_k=H$ and $H_0=(1_2)$, such that H_{i-1} is a wave-move of H_i ($i=1, \dots, k$), and H' be a band-move of H along a band, then H' is also reducible or isomorphic to (1_2) .

A proof of $P(k)$ for every non-negative integer k will prove the lemma. It is clear that Lemma 10 establishes $P(0)$. Let us assume that $P(k-1)$ and then we will verify that $P(k)$ holds. Suppose that there is a finite sequence of (normal) Heegaard diagrams, H_k, H_{k-1}, \dots, H_0 , with $H_k=H$ and $H_0=(1_2)$, such that H_{i-1} is the wave-move of H_i along a wave τ_i ($i=1, 2, \dots, k$), and let H' be

a band-move of H along a band α . Let $H=(F; v, w)$ with $v=v_1 \cup v_2$ and $w=w_1 \cup w_2$. We can assume without loss of generality that the band α joins v_1 and v_2 . Let $v_3=v_1 \# v_2$. By Lemma 6, we may assume (a) α is a parallel band.

Therefore, α is contained in a major domain U and there exists two edges E_1, E_2 in ∂U such that one of connected components of $cl(\partial U - E_1 \cup E_2)$ consists of only one edge E in w , where E_1 (resp. E_2) is an edge in v_1 (resp. v_2) and α joins their interior points. By Assumption (a) and Lemma 7, we may assume (b) τ_k is associated with w_1 . Let Q be the set of domains of H . By Lemma 5, there exists an involution T on F such that, for every U' in Q , $T(U')$ is also contained in Q . Let $G(x, H_i)$ be a W -graph of H_i along x , where x is one of the two complete systems of meridians of H_i . By Lemma 4, $G(w, H)$ is one of the three graphs illustrated in Figure 3, with edge-parameters, a, b, c , and d , and $G(v, H)$ is a graph with edge-parameters, a', b', c' , and d' . By Lemma 9, we may assume without loss of generality that $a \neq \emptyset$ and $c \neq \emptyset$. In this context, we will verify the following sublemmata, which establish the statement $P(k)$ and so the proof of the lemma;

Sub-Lemma 11-1. *If $b=0$ and $d=0$ in $G(w, H)$, then $P(k)$ holds.*

Proof. Since $G(w, H)$ is a W -graph with $b=0$ and $d=0$, the set of domains Q contains only one major domain U , with $T(U)=U$, whose boundary consists of exactly 12 edges, $E_1^k, E_2^k, \dots, E_{12}^k$, where $E_1^k, E_3^k, \dots, E_{11}^k$ are contained in v and $E_2^k, E_4^k, \dots, E_{12}^k$ are in w . (See Figure 7.)

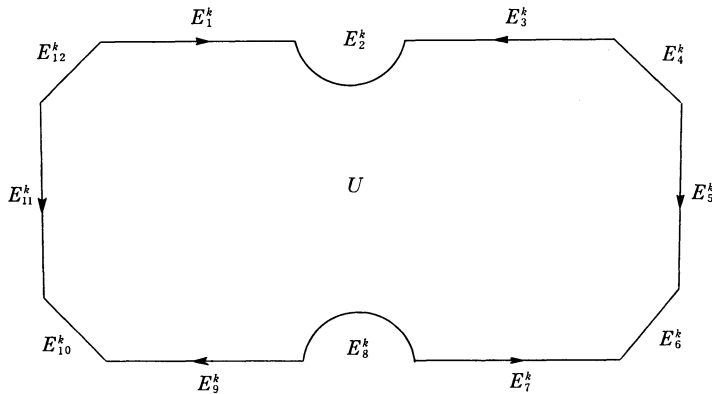

Figure 7.

By the condition that $b=0$, we can assume that both v_1 and v_2 intersect each of w_1 and w_2 with the same signed intersections. Thus all of the edges have the orientations given by Figure 7. Next E_{1+2i}^k and E_{7+2i}^k ($i=0, 1, 2$) are contained in the same meridian in v , because $T(U)=U$ and $T(E_{1+2i}^k)=E_{7+2i}^k$ by Lemma 5. By the way, E_2^k and E_8^k (resp. E_4^k, E_6^k, E_{10}^k , and E_{12}^k) are contained

in w_2 (resp. w_1). The following table determines the boundary of U ;

| | (1) | (2) | (3) | (4) | (5) | (6) | (7) | (8) |
|------------------|-------|-------|-------|-------|-------|-------|-------|-------|
| $E_1^k(\subset)$ | v_1 | v_1 | v_1 | v_1 | v_2 | v_2 | v_2 | v_2 |
| $E_3^k(\subset)$ | v_1 | v_1 | v_2 | v_2 | v_1 | v_1 | v_2 | v_2 |
| $E_5^k(\subset)$ | v_1 | v_2 | v_1 | v_2 | v_1 | v_2 | v_1 | v_2 |

By the definition of Heegaard diagrams, the cases (1) and (8) cannot occur. By renumbering the index i of v_i ($i=1, 2$), the cases (5), (6), (7) are obtained from the cases (4), (3), (2), respectively. Furthermore the case (4) is obtained from a slight modification of the case (3). Thus we will check the cases (2) and (3);

(2): In this case, U is the domain illustrated in Figure 8. We will verify that this case does not happen except the special case. Let U^* be the dual domain of U . (Note that $U^*=U$.) Then U^* is the domain illustrated in Figure 9. We may assume that τ_k is the wave illustrated in Figure 9. It

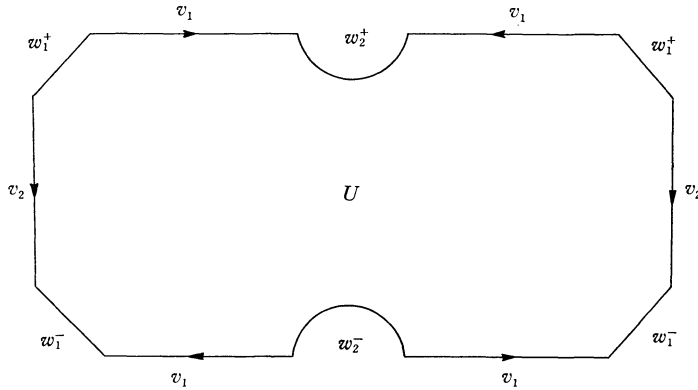

Figure 8.

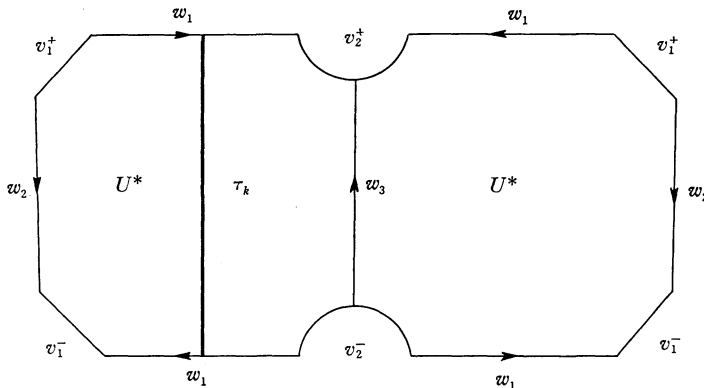

Figure 9.

will be noticed that if τ' and τ'' are any two waves associated with w_1 , then $w_1(\tau')$ and $w_1(\tau'')$ are isotopic on F . Let $w_3 = w_1(\tau_k)$. Then $w_3 \cap U^*$ is a segment joining v_2^+ and v_2^- , as illustrated in Figure 9, since w_3 is isotopic on F to neither w_1 nor w_2 . Thus $H_{k-1} = (F; v, w_2 \cup w_3)$ has a W -graph $G(v, H_{k-1})$ with edge-parameters, $a'_{k-1}, b'_{k-1}, c'_{k-1}$, and d'_{k-1} , such that $b'_{k-1} = 0$ and $d'_{k-1} = 1$. We remark that $G(v, H_{k-1})$ is of type I. Then two cases happen;

Case (2.1): $a'_{k-1} \neq 0$; let Q_{k-1} be the set of domains of H_{k-1} . Then Q_{k-1} has exactly two major domains, U_1 and U_2 . Since $G(v, H_{k-1})$ is of type I with $a'_{k-1} \neq 0, c'_{k-1} \neq 0$, and $d'_{k-1} \neq 0$, the wave τ_{k-1} is associated with $\tilde{w}(\tau_k) = w_2 \cup w_3$. We may assume that τ_{k-1} is contained in U_1 . Let E'_1 and E'_2 be the distinguished edges of τ_{k-1} . By the condition that $b'_{k-1} = 0$, all edges of U_1 and U_2 in $\tilde{w}(\tau_k)$ are simply oriented as given in Figure 10.1. Then E'_1 (resp. E'_2) is an edge in U_1 joining either v_1^+ and v_2^+ (resp. v_1^- and v_2^-) or v_1^+ and v_1^- (resp. v_2^+ and v_2^-). Since the edge joining v_1^+ and v_1^- in U_1 is contained in w_2 and the one joining v_2^+ and v_2^- in U_1 is in w_3 , we can assume that E'_1 (resp. E'_2) is an edge joining v_1^+ and v_2^+ (resp. v_1^- and v_2^-). Let us suppose that τ_{k-1} is associated with w_2 . Let $w_4 = w_2(\tau_{k-1})$. To find the connection of w_4 with v in U_1 , we make use of a band given by Lemma 8. Let α' be the band joining w_2 and w_3 , illustrated in Figure 10.1.

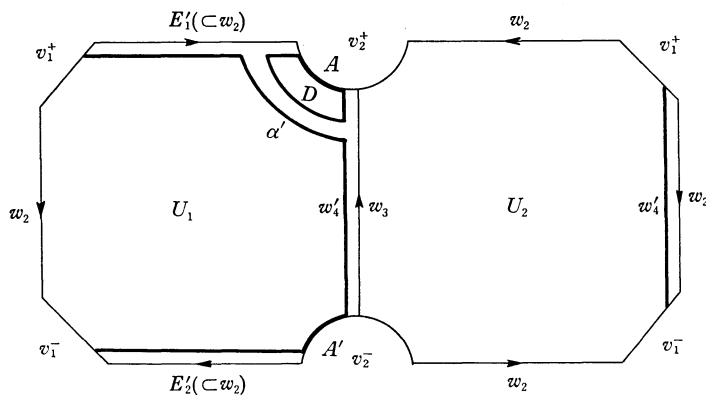

Figure 10.1.

By Lemma 7, $w_2 \# w_3 = w'_4$ is isotopic on F to w_4 . Let D be the 2-disk in U_1 bounded by w'_4 and v and let $A = v \cap \partial D, A' = v_2^- \cap \partial U_1$. Then there exists a finite sequence of 2-disks on F such that any one intersects the next one at an edge, the first one does D at A , and the last one contains A' in its boundary. Let D' be the union of those 2-disks and D . By an isotopy deformation of w'_4 on F with respect to v through D' , the circle \hat{w}'_4 is obtained as a result. (See Figure 10.2.) Thus $\hat{w}'_4 \cap U_1$ is a segment joining v_1^+ and v_1^- and $\hat{w}'_4 \cap U_2$ is a segment joining v_1^+ and v_1^- because D' is disjoint from U_2 . Since w_4 is isotopic

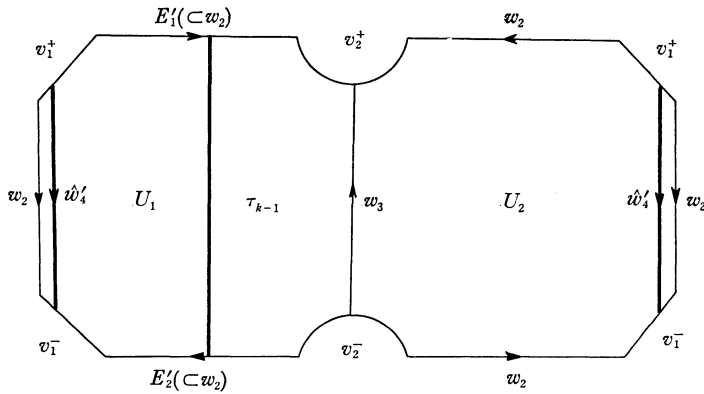

Figure 10.2.

on F to \hat{w}'_4 , H_{k-2} is isomorphic to $(F; v, w_3 \cup \hat{w}'_4)$ by Lemma 2 in [6] and so it has a W -graph $G(v, H_{k-2})$ of type I with edge-parameters, a'_{k-2} , b'_{k-2} , c'_{k-2} , and d'_{k-2} , where $b'_{k-2}=0$, $c'_{k-2} \geq 2$, and $d'_{k-2}=1$.

Similarly if τ_{k-1} is associated with w_3 , then $w_5 \cap U_1$ and $w_5 \cap U_2$ are segments joining v_2^+ and v_2^- , where $w_5 = w_3(\tau_{k-1})$, and $H_{k-2} = (F; v, w_2 \cup w_5)$ has a W -graph $G(v, H_{k-2})$ of type I with edge-parameters, a'_{k-2} , b'_{k-2} , c'_{k-2} , and d'_{k-2} , where $b'_{k-2}=0$, $c'_{k-2} \neq 0$, and $d'_{k-2} \geq 2$. In the first case, by the condition that $c'_{k-2} \geq 2$ and $b'_{k-2}=0$ and by Lemma 9, a'_{k-2} is not zero. In the second case, by the condition that $d'_{k-2} \geq 2$ and $b'_{k-2}=0$ and by Lemma 9, a'_{k-2} is not zero. Repeating the above argument, at the final step H_0 has a W -graph $G(v, H_0)$ of type I with edge-parameters, a'_0 , b'_0 , c'_0 , and d'_0 , where $b'_0=0$ and either $c'_0 \geq 2$ or $d'_0 \geq 2$. But it is impossible, since H_0 is the canonical Heegaard diagram (1_2) and so the edge-parameter a'_0 is zero. Thus this case (2.1) does not happen.

Case (2.2): $a'_{k-1}=0$; in this case, w_2 is disjoint from v_2 by the condition that $b'_{k-1}=0$. And so it intersects v_1 at only one point, because H_k is a Heegaard diagram of S^3 . Of course, w_1 also intersects v_2 at only one point and v_1 at only one point, because $a'_k \neq 0$ and $b'_k=0$ and $G(v, H_k)$ is of type I. Hence, by the condition that $\alpha \cap w = \emptyset$, H' is the canonical one (1_2) or it has a wave τ' such that $H'(\tau')$ is isomorphic to (1_2) , where $H'(\tau')$ is the wave-move of H' along τ' .

(3): In this case, U is the domain illustrated in Figure 11. Then we have the following table, which describes the relation between the band α and the edges joined by it;

| | (3.1) | (3.2) | (3.3) | (3.4) |
|----------|---------|---------|---------|------------|
| $E_1(=)$ | E_1^k | E_3^k | E_7^k | E_9^k |
| $E(=)$ | E_2^k | E_4^k | E_8^k | E_{10}^k |
| $E_2(=)$ | E_3^k | E_5^k | E_9^k | E_{11}^k |

domain U_i contains in its boundary exactly 8 edges, $E_1^i, E_2^i, E_3^i, E_4^i, E_5^i, E_6^i, E_7^i, E_8^i$, where E_1^i, E_3^i, E_5^i , and E_7^i (resp. E_2^i, E_4^i, E_6^i , and E_8^i) are contained in v (resp. w) ($i=1, 2$). (See Figure 12.2.) We note that by the condition that $b_k=0$ all of those edges are simply oriented as illustrated in Figure 12. Let $\alpha_1, \alpha_2, \alpha_3$, and α_4 be the bands illustrated in Figure 12.1 or 12.2.

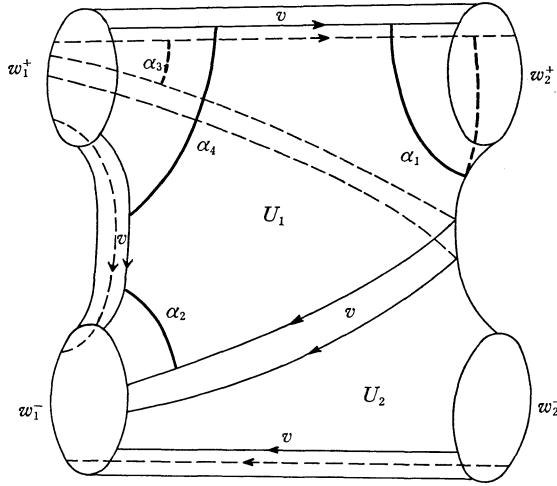

Figure 12.1

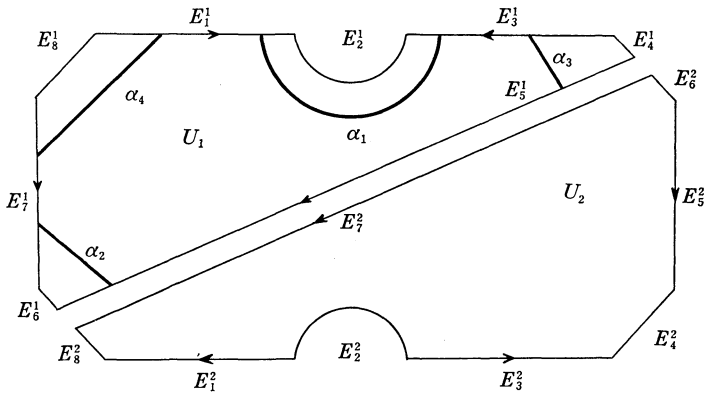

Figure 12.2

Since the band α is a parallel one in U_1 , we may assume that it must be one of those bands. Thus we divide the proof into two cases as follows;

Case (1): $\alpha=\alpha_1$ or α_2 ; in this case, we will verify that $\hat{\theta}_3 \cap U_1$ (resp. $\hat{\theta}_3 \cap U_2$) is not a segment joining either w_1^- and w_2^+ or w_1^+ and w_2^- and then the wave τ_k remains to be a wave of H' . Let us suppose that $\alpha=\alpha_1$. Then we have that $E_1=E_1^1$, $E=E_2^1$, and $E_2=E_3^1$ and $T(E_1^1)=E_3^2$, $T(E_3^1)=E_7^2$. Thus E_1^1 and E_3^2

resp. $(E_3^1$ and $E_1^2)$ are contained in v_1 (resp. v_2). Moreover $T(E_5^1)=E_7^2$ and $T(E_7^1)=E_5^2$ and so E_5^1 and E_7^2 (resp. E_7^1 and E_5^2) are contained in the same meridian. Thus we have the following table;

| | | | | |
|---------|-------|-------|-------|-------|
| | (1) | (2) | (3) | (4) |
| E_5^1 | v_1 | v_1 | v_2 | v_2 |
| E_7^1 | v_1 | v_2 | v_1 | v_2 |

In the case (1), $v_3 \cap U_1$ and $v_3 \cap U_2$ are illustrated as the fatted lines in Figure 12.3.

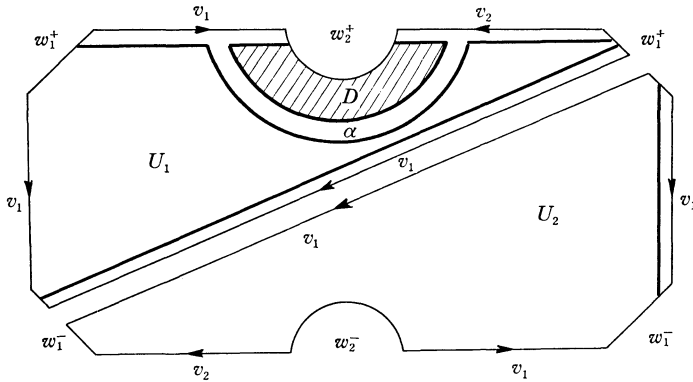

Figure 12.3

Let D be the 2-disk bounded by E and v_3 , as illustrated in Figure 12.3. Then, by an isotopy deformation of v_3 on F with respect to w , the disk D can be eliminated from U_1 turning into U_1 itself through E_4^1 . As a result, $\hat{v}_3 \cap U_1$ and $\hat{v}_3 \cap U_2$ are segments joining w_1^+ and w_1^- . Thus the first assertion holds. In the cases (2), (3), (4), by the similar argument as above, $\hat{v}_3 \cap U_1$ and $\hat{v}_3 \cap U_2$ are not segments joining either w_1^- and w_2^+ or w_1^+ and w_2^- . Next if $\alpha = \alpha_2$, then the assertion also holds by the argument as above. Thus, in all the cases, the wave τ_k remains to be a wave of H' by Lemma 9. Now α is also a band joining v_1 and v_2 in H_{k-1} . Let $H'(\tau_k)$ be the wave-move of H' through w_1 along τ_k and $(H_{k-1})'$ be a band-move of H_{k-1} along α . By Lemma 8 and Lemma 2, $H'(\tau_k)$ is isomorphic to $(H_{k-1})'$. By Assumption $P(k-1)$, $(H_{k-1})'$ is reducible and so H' itself is also reducible.

Case (2): $\alpha = \alpha_3$ or α_4 ; let us suppose that $\alpha = \alpha_3$. Then we have that $E_1 = E_3^1$, $E_4^1 = E_4^1$, and $E_2 = E_5^1$ and then $T(E_3^1) = E_1^2$, $T(E_5^1) = E_7^2$. Thus E_3^1 and E_1^2 (resp. E_5^1 and E_7^2) are contained in v_1 (resp. v_2). Moreover $T(E_1^1) = E_3^2$ and $T(E_7^1) = E_5^2$ and so E_1^1 and E_3^2 (resp. E_7^1 and E_5^2) are contained in the same meridian. Thus we have the following table;

| | | | | |
|---------|-------|-------|-------|-------|
| | (1) | (2) | (3) | (4) |
| E_1^1 | v_1 | v_1 | v_2 | v_2 |
| E_7^1 | v_1 | v_2 | v_1 | v_2 |

In the case (1), $v_3 \cap U_1$ and $v_3 \cap U_2$ are illustrated as the fatted lines in Figure 12.4 and so $\hat{\vartheta}_3 \cap U_1$ (resp. $\hat{\vartheta}_3 \cap U_2$) is a segment joining w_1^+ and w_2^+ (resp. w_1^- and w_2^-).

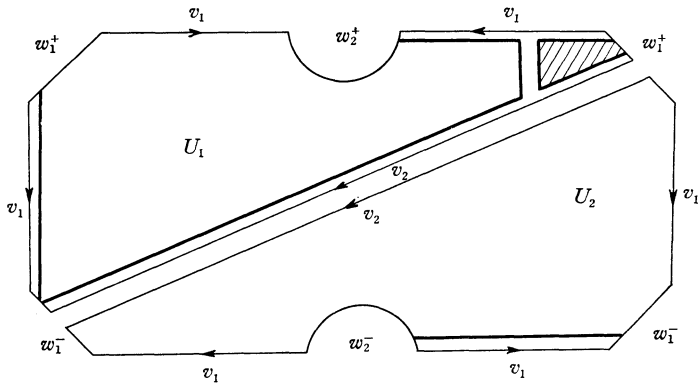

Figure 12.4

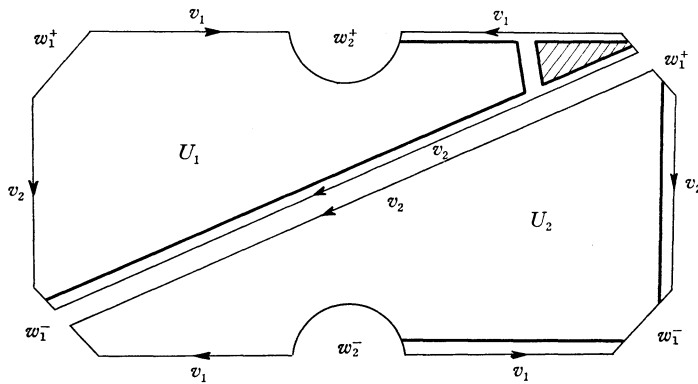

Figure 12.5

In the case (2), $v_3 \cap U_1$ and $v_3 \cap U_2$ are illustrated in Figure 12.5 and so $\hat{\vartheta}_3 \cap U_1$ (resp. $\hat{\vartheta}_3 \cap U_2$) is a segment joining w_1^- and w_2^+ (resp. w_1^+ and w_2^-). In the case (3), $v_3 \cap U_1$ and $v_3 \cap U_2$ are illustrated as the fatted lines in Figure 12.6 and so $\hat{\vartheta}_3 \cap U_1$ is two segments joining either w_1^+ and w_1^- or w_1^+ and w_2^+ and $\hat{\vartheta}_3 \cap U_2$ is empty. In the case (4), $v_3 \cap U_1$ and $v_3 \cap U_2$ are illustrated in Figure 12.7 and so $\hat{\vartheta}_3 \cap U_1$ and $\hat{\vartheta}_3 \cap U_2$ are segments joining w_1^+ and w_1^- .

In the cases of (1), (3), and (4), τ_k remains to be a wave of H' by Lemma 9 and then the argument in the case of $\alpha = \alpha_1$ can be applied to these cases.

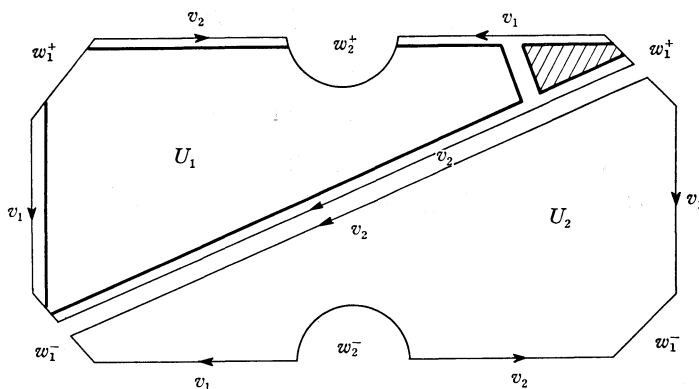

Figure 12.6

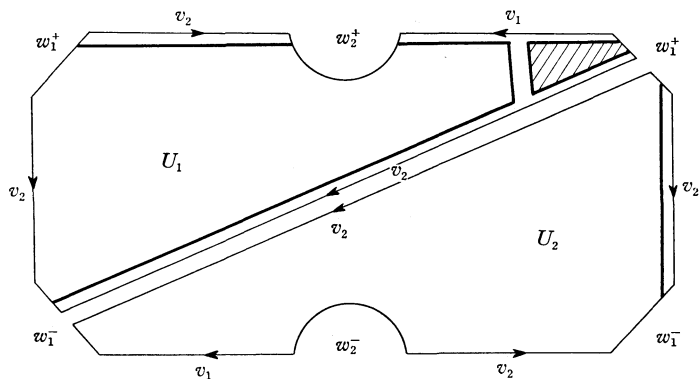

Figure 12.7

Hence H' is also reducible. Thus we will check the case of (2); in this case, H is the Heegaard diagram illustrated in Figure 13. Then we will verify that the edge-parameter a is not less than two. For if $a=1$, then v_1 intersects w_2 at only one point and v_2 cannot intersect w_2 . Now H is a Heegaard diagram of S^3 and so v_2 intersects w_1 at only one point. But it is impossible since H is given by Figure 13 and so v_2 contains two edges joining w_1^+ and w_1^- . Hence $a \geq 2$, $b=0$, $c \neq 0$, and $d \neq 0$ in $G(w, H)$. Then w_1 (resp. w_2) intersects v_2 (resp. v_1) twice one after another and so $G(v, H)$ is of type I with edge-parameters, a' , b' , c' , and d' , where $b'=0$, $a' \neq 0$, $c' \neq 0$, and $d' \neq 0$. Hence the two domains U_1 and U_2 are given by Figure 14.

But we have verified in the argument of Case (2.1) in Sub-Lemma 11-1 that the set of domains Q does not contain such domains. In the case that $\alpha = \alpha_4$, the same result are obtained by the similar manner in the case that $\alpha = \alpha_3$. Hence the proof of the lemma is complete.

Sub-Lemma 11-3. *If $b \neq 0$ in $G(w, H)$, then $P(k)$ holds.*

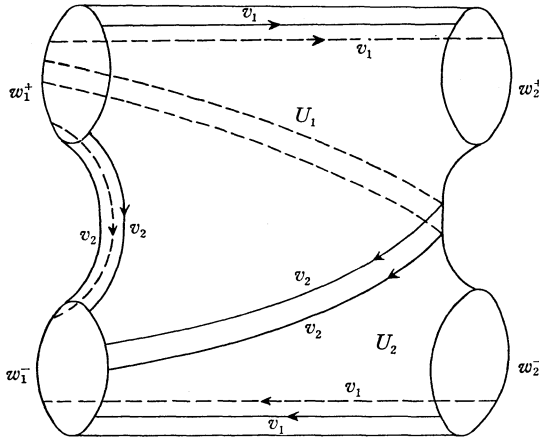

Figure 13.

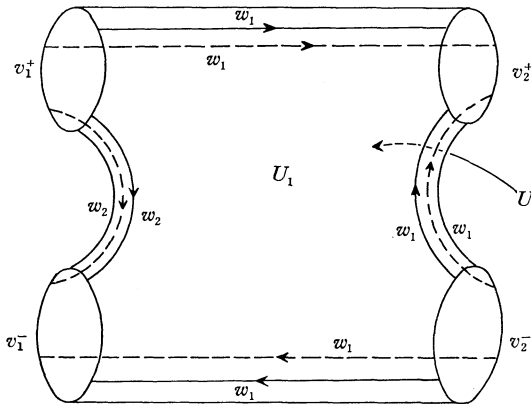

Figure 14.

Proof. By Assumption (b), $G(w, H)$ is of type III. Since ∂_3 is disjoint from v , by Lemma 9 τ_k remains to be a wave of H' , which is also associated with w_1 . Of course, α remains to be a band joining v_1 and v_2 in H_{k-1} . Then it is easily verified by Lemma 8 and Lemma 2 that $H'(\tau_k)$ is isomorphic to $(H_{k-1})'$. Thus by the inductive statement $P(k-1)$, H' is also reducible.

Finally we have the following theorem from Lemma 3, Lemma 10, and Lemma 11;

Main Theorem. *All Heegaard diagrams of genus two of the 3-sphere S^3 other than the canonical one are always reducible.*

Proof. Let $H=(F; v, w)$ be an arbitrary Heegaard diagram other than the canonical one and let $F(0)$ be the Heegaard surface of (1_2) . Then, by Waldhausen [8], there is a homeomorphism h of S^3 such that $h(F)=F(0)$. Let $h(H)$

$= (F(0); h(v), h(w))$. By Lemma 3, there is a finite sequence of Heegaard diagrams, H_0, H_1, \dots, H_k , with $H_0 = (1_2)$ and $H_k = h(H)$, such that H_i is a band-move of H_{i-1} ($i=1, 2, \dots, k$). Then we make the following induction statement;

$R(k)$: If there is a finite sequence of Heegaard diagrams, H_0, H_1, \dots, H_k , with $H_0 = (1_2)$ and $H_k = H$, such that H_i is a band-move of H_{i-1} ($i=1, 2, \dots, k$), then H is reducible.

A proof of $R(k)$ for every positive integer k will prove the theorem. By Lemma 10, $R(1)$ is true. Thus assume $R(k-1)$, and suppose that there is a finite sequence of Heegaard diagrams, H_0, H_1, \dots, H_k , with $H_0 = (1_2)$ and $H_k = H$, such that H_i is a band-move of H_{i-1} ($i=1, 2, \dots, k$). We may assume that all the Heegaard diagrams except H_0 are not the canonical one (1_2) . By $R(k-1)$, H_{k-1} is reducible. Since H_k is a band-move of H_{k-1} , H_k is also reducible by Main Lemma 11. Thus $R(k)$ is also true and so the proof of the theorem is complete.

By Main Theorem, we can determine whether a Heegaard diagram of genus two represents the 3-sphere S^3 or not. Thus we have;

Corollary 1. *There is an algorithm for recognizing S^3 in the class of 3-manifolds of genus two.*

We remark that Birman-Hilden [1] and [2] had already discovered an algorithm to decide whether a 3-manifold with Heegaard splittings of genus two is the 3-sphere S^3 , but their algorithm is based on Haken's algorithm [3].

As an application of Main Theorem, we are interested in the relationships between presentations of the fundamental group of the 3-sphere S^3 and its Heegaard diagrams of genus two. Let $(F; v, w)$ be a Heegaard diagram of a Heegaard splitting $(V, W; F)$ of genus two of a 3-manifold M . Let us consider a presentation of the fundamental group $\pi_1(M)$; orient the circles v_1, v_2 in v and w_1, w_2 in w . Construct from each w_i a (cyclic) word $R_i = \prod_j v_{\mu_{ij}}^{\varepsilon_{ij}}$, where $\varepsilon_{ij} = \pm$ records the ordered array of signed intersections of w_i with the circles in v . We note that from each word R_i a unique cyclic word \vec{R}_i is constructed by joining the beginning and the end of R_i and preserving the sequential order of letters in R_i . Then $\Pi(v) = \{\vec{v}_1, \vec{v}_2; \vec{R}_1, \vec{R}_2\}$ is a presentation of $\pi_1(M)$. A dual presentation $\Pi(w) = \{\vec{w}_1, \vec{w}_2; \vec{R}'_1, \vec{R}'_2\}$ is also defined in an analogous manner. Now we may assume that both words in the presentation $\Pi(v)$ (resp. $\Pi(w)$) contain no consecutive letters $\vec{v}_i \vec{v}_i^{-1}, \vec{v}_i^{-1} \vec{v}_i$ (resp. $\vec{w}_i \vec{w}_i^{-1}, \vec{w}_i^{-1} \vec{w}_i$) ($i=1, 2$). For if some word \vec{R}_j contains a consecutive letters $\vec{v}_i \vec{v}_i^{-1}$, then the W -graph $G(v, H)$ is of type III and there exists a wave τ associated with v_i . Thus the wave-move $H(\tau)$ of H along τ is obtained and so a new presentation associated with $H(\tau)$ is also obtained. It is easy to see that the total length of words in the new one is less than in the old one. Next $\Pi(v)$ (resp. $\Pi(w)$) is called to be π_1 -

reducible if one of the two words \vec{R}_1 and \vec{R}_2 (resp. \vec{R}'_2 and \vec{R}'_1) is contained in the other as a cyclic word.

Corollary 2. *Let us suppose that M is the 3-sphere S^3 . If $G(v, H)$ is of type I or II but not III, then $\Pi(v)$ is π_1 -reducible.*

Proof. Since $H = (F; v, w)$ is a Heegaard diagram of S^3 , by Main Theorem there exists a wave τ associated with some meridian in v or w . Since $G(v, H)$ is not of type III, we may assume that the wave τ is associated with w_1 . Then $G(w, H)$ is of type III and so the word \vec{R}_2 is contained in \vec{R}_1 as cyclic word, because τ is associated with w_1 . This completes the proof.

Next let us consider two examples of presentations associated with Heegaard diagrams. Let $a = \vec{v}_1$ and $b = \vec{v}_2$.

$$\text{EXAMPLE 1. } \pi_1(M) = \{a, b; a^2 = b^{-1}aba^{-1}b^{-1}abab^{-1}a^{-1}bab^{-1} \\ b^2 = a^{-1}bab^{-1}a^{-1}baba^{-1}b^{-1}aba^{-1}\}$$

In this case, the manifold M is a homology 3-sphere but it is not the 3-sphere S^3 by Corollary 2.

$$\text{EXAMPLE 2. } \pi_1(M) = \{a, b; ba^2b^2a^2b^2a^2b^2ba^{-1} = b^3a^2b^2a^2b^2a^2 = 1\}$$

In this case, the manifold M is the 3-sphere S^3 and the presentation is really π_1 -reducible.

References

- [1] J.S. Birman and H.M. Hilden: *Heegaard splittings of branched coverings of S^3* , Trans. Amer. Math. Soc. **213** (1975), 315–352.
- [2] J.S. Birman: *Heegaard splittings, diagrams and sewings for closed, orientable 3-manifolds*, Lecture notes for CBMS conference at Blacksburg, Va., Oct. 8–120, 1977.
- [3] W. Haken: *Theorie der Normalflächen*, Acta Math. **105** (1961), 245–375.
- [4] M. Ochiai: *Dehn's surgery along 2-bridge knots*, The Yokohama Math. J. XXVI (1978), 69–75.
- [5] ———: *A counterexample to a conjecture of Whitehead and Volod'in-Kuznetsov-Fomenko*, J. Math. Soc. Japan **31** (1979), 687–691.
- [6] ———: *Heegaard-Diagrams and Whitehead-Graphs*, Math. Sem. Notes of Kobe Univ. **7** (1979), 573–590.
- [7] I.A. Volodin, V.E. Kuznetsov, and A.T. Fomenko: *The problem of discriminating algorithmically the standard three-dimensional sphere*, Russian Math. Surveys **29**: 5 (1974), 71–172.
- [8] F. Waldhausen: *Heegaard-Zerlegungen der 3-Sphäre*, Topology **7** (1968), 195–203.

- [9] J.H.C. Whitehead: *On certain sets of elements in a free group*, Proc. London Math. Soc. (2) **41** (1936), 48–56.
- [10] H. Zieschang: *Über einfache Kurven auf Vollbrezeln*, Abn. Math. Sem. Univ. Hamburg **25** (1962), 231–250.
- [11] O. Morikawa: *A counterexample in the case of genus three to a conjecture of Whitehead*, to appear in Math. Sem. Notes of Kobe Univ.

Tatsuo Homma
Department of Information Science
Tokyo Institute of Technology
Oh-okayama, Meguro-ku, Tokyo 152
Japan

Mitsuyuki Ochiai
Department of Mathematics
Osaka University
Toyonaka, Osaka 560
Japan

Moto-o Takahashi
Department of Mathematics
Tsukuba University
Sakura-mura, Niihari-gun, Ibaraki 305
Japan