

# Effects of Perylene Concentration on Luminous Characteristics of Poly (*N*-vinylcarbazole) Based Organic EL Device

Yasuhiro AKITA\*, Kenji TANAKA\*\*, Yoshiharu MAEKAWA\*\*\*, Minoru KUSABIRAKI\*\*\*\* and Masao AOZASA\*\*\*\*\*

( Received October 15, 2001 )

## Synopsis

Organic electroluminescent (EL) device was fabricated using poly (*N*-vinylcarbazole) (PVCz) film doped with perylene dye. Effects of the perylene dye concentration on the electric current and luminous characteristics of the EL device and photoluminescent (PL) spectrum of perylene-doped PVCz film were investigated. It was found that the luminous characteristic of EL device and PL spectrum of perylene-doped PVCz film depend strongly on the concentration of perylene dye.

KEYWORDS: Organic EL device, Poly (*N*-vinylcarbazole) , Perylene

## 1. Introduction

Organic electroluminescent (EL) device using fluorescent phenomenon of the organic material is expected as a thin flat-panel display of the next generation. Organic materials are generally classified into two classes, the low weight molecular material and the polymer. We fabricated an organic EL device using thin polymer film doped with fluorescent dye casted by spin-coating method and investigated effects of dopant concentration in the host polymer on luminous characteristics of EL devices.

## 2. Experimental

Fig. 1 shows the molecular structures of PVCz (SCIENTIFIC POLYMER PRODUCTS, INC. , Mw=132,000) and perylene (TOKYO KASEI KOGYO CO., LTD.) used in this study. The cleaned Indium-Tin Oxide (ITO) coated glass (MATSUNAMI GLASS IND., LTD., Corning #7059 25 × 25 × 0.6 (mm) ) was used as a substrate. The PVCz and perylene molecules were dissolved in benzene. The concentration of PVCz in benzene was changed from 5 mg/ml to 15 mg/ml and that of perylene in PVCz from 2 mol% to 8 mol%. Perylene-doped PVCz thin films were prepared by spin-coating method, and Al-Li (KOJUNDO CHEMICAL LABORATORY CO., LTD.) electrode was formed by vacuum

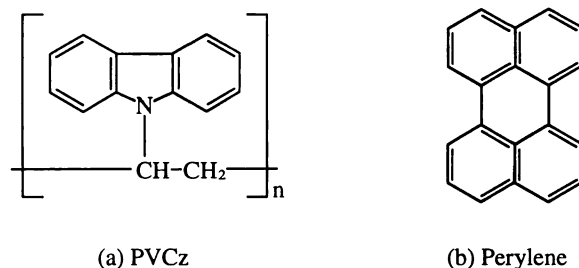

Fig. 1: Molecular structures.

\*Student, Master Course of Dept. of Electrical Engineering

\*\*Research Associate, Dept. of Electrical Engineering

\*\*\*Lecturer, Dept. of Electrical Engineering

\*\*\*\*Associate Professor, Dept. of Electrical Engineering

\*\*\*\*\*Professor, Dept. of Electrical Engineering

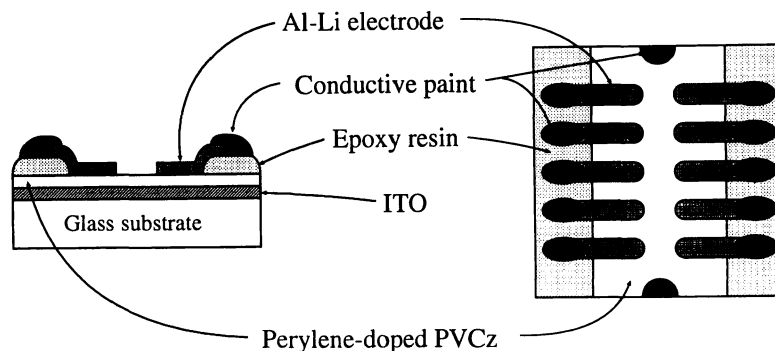

Fig. 2: Structure of organic EL device.

vapor deposition in a vacuum of  $10^{-6}$  Torr. We fabricated a single layer EL device [ITO/Perylene-doped PVCz/Al-Li] in this study. Fig. 2 shows a schematic structure of EL device for investigating the electrical and luminous characteristics.

The schematic diagram of the measurement system for current-voltage and luminance-voltage characteristics of the organic EL device is shown in the Fig. 3 GP-IB programmer was controlled through GP-IB interface by a computer, and DC voltage was applied to the device. Voltage, current density and output voltage from luminance meter were taken in the computer through an Analog/Digital (A/D) converter. Fig. 4 shows a measurement system of the luminous spectrum. The monochromized emission detected by an monochromator and a photomultiplier was taken into the computer through the A/D converter. All measurements were performed at room temperature in the atmosphere.

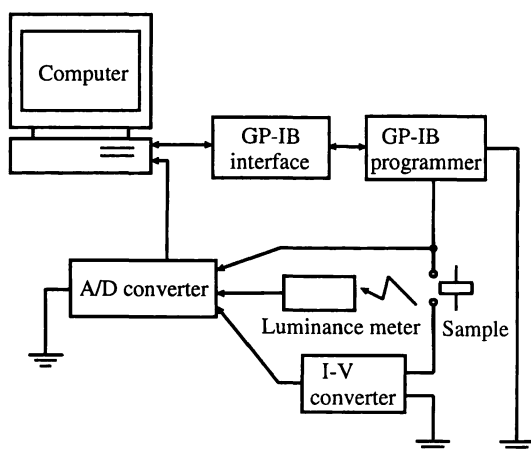

Fig. 3: Schematic diagram of current and luminance measurement system.

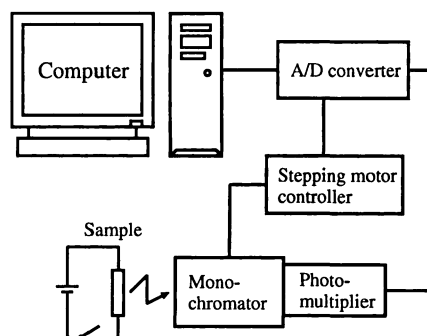
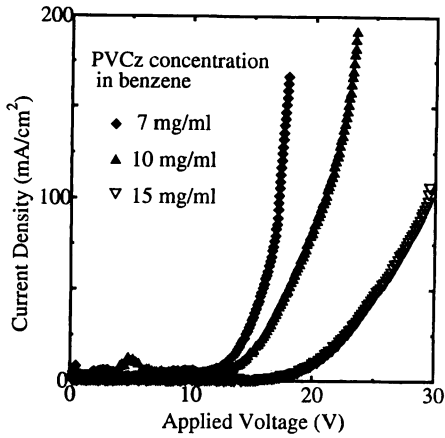

Fig. 4: Schematic diagram of luminous spectrum measurement system.

### 3. Experimental results and discussions

#### 3.1 Current density versus applied voltage characteristics

Fig. 5 shows current density versus applied voltage characteristics when the concentration of PVCz in benzene is changed at the constant concentrations of perylene in benzene 2 mol% and 5 mol%. The figures show that threshold voltage increase as the concentrations of perylene and PVCz increase.



(a) Perylene-doped PVCz : 2 mol%

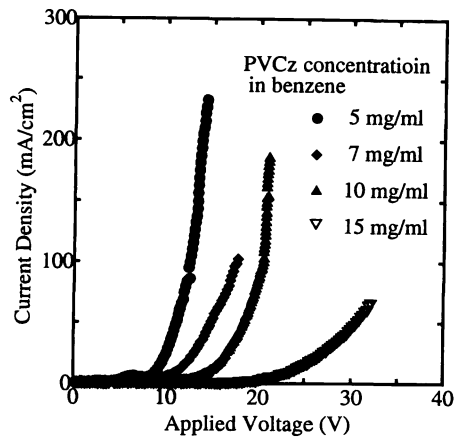

(b) Perylene-doped PVCz : 5 mol%

Fig. 5: Current density versus applied voltage characteristics of EL device.

### 3.2 Luminance versus applied voltage characteristics

Luminance versus applied voltage characteristics are shown in the Fig. 6 when the concentration of PVCz is changed at the concentrations of perylene 2 mol% and 5 mol%. It is found that the concentrations of PVCz to show the highest luminance are 15 mg/ml and 8 mg/ml at the concentrations of perylene 2 mol% and 5 mol%, respectively.

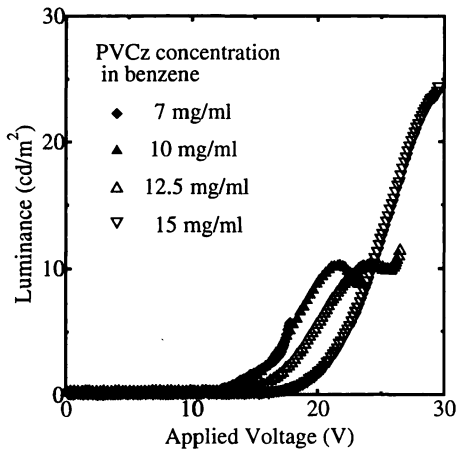

(a) Perylene-doped PVCz : 2 mol%

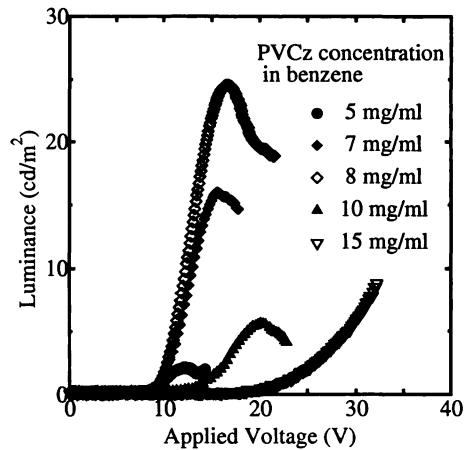

(b) Perylene-doped PVCz : 5 mol%

Fig. 6: Luminance versus applied voltage characteristics of EL device.

### 3.3 Luminance versus current density characteristics

Fig. 7 shows luminance versus current density characteristics at dopant concentration of perylene 2 mol% and 8 mol%. It is found that the concentrations of PVCz which show the highest luminescent efficiency are 15 mg/ml and 6 mg/ml at the concentrations of perylene 2 mol% and 8 mol%, respectively. Table 1 shows a list of current density, concentration of PVCz and luminescent efficiency at the 20 cd/m<sup>2</sup> luminance. The values at 20 cd/m<sup>2</sup> were estimated by extrapolation of the straight line in Fig. 7. The table shows that the maximum luminescent efficiency is observed for the sample prepared at the perylene concentration of 8 mol% and the PVCz concentration of 6 mg/ml. The higher luminescent efficiency might be attained by further optimization.

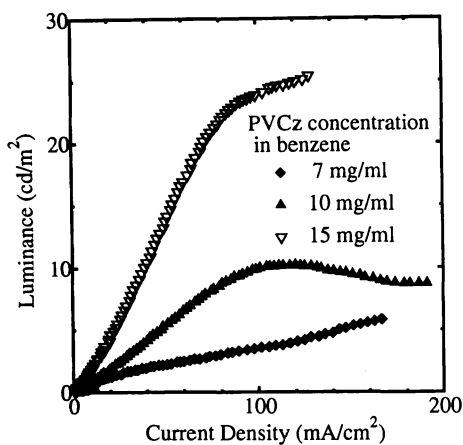

(a) Perylene-doped PVCz : 2 mol%

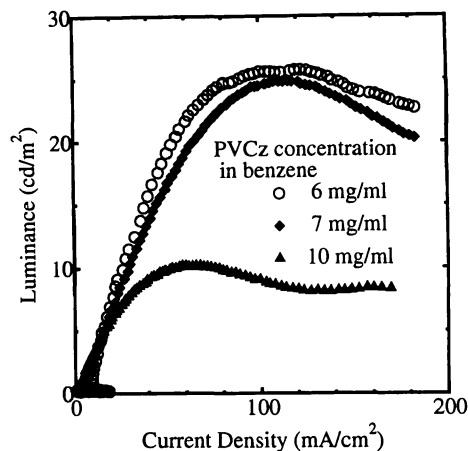

(b) Perylene-doped PVCz : 8 mol%

Fig. 7: Luminance versus current density characteristics.

Table 1: Characteristic of organic EL device.

Concentration of perylene	2 mol%	5 mol%	8 mol%
Concentration of PVCz	15 mg/ml	8 mg/ml	6 mg/ml
Current density	71 mA/cm <sup>2</sup>	62 mA/cm <sup>2</sup>	53 mA/cm <sup>2</sup>
Luminescent efficiency	$2.8 \times 10^{-2}$ cd/A	$3.2 \times 10^{-2}$ cd/A	$3.7 \times 10^{-2}$ cd/A

### 3.4 EL and PL spectra

Fig. 8 and Fig. 9 show EL and PL spectra at each concentration of perylene and PVCz. Luminescent color is green at the concentration of perylene 5 mol% and 8 mol%, and light blue at the 2 mol% doping. Three luminescent peaks due to the luminescence of perylene<sup>1)</sup> are observed. As the dopant concentration increases, luminous spectrum shifts to longer wave side.

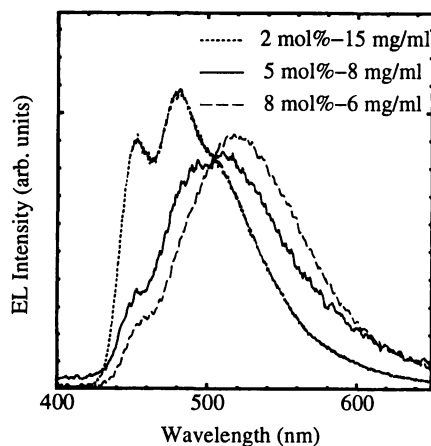

Fig. 8: EL spectra.

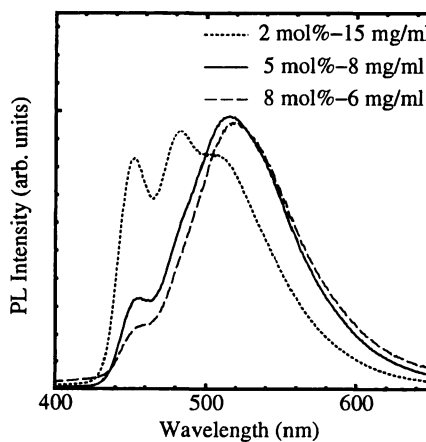

Fig. 9: PL spectra.

#### 4. Conclusion

The conclusions can be summarized as follows :

1. Luminance strongly depends on dopant concentration of perylene.
2. The concentration of PVCz in benzen which shows a maximum luminance depends on the concentration of perylene.
3. Luminescent efficiency is improved as the concentration of perylene increases under the examined concentration range.
4. Luminescent peak of perylene shifted to the longer wave side by increasing the dopant concentration.

#### Reference

- 1) Jiamin Zhao, *et al.*, *Thin Solid Films*, **363**, 201-203 (2000)