

UTILIZATION OF WASTE PLASTICS IN ASPHALT MIXTURES

Osamu KAMADA* and Masaru YAMADA**

(Received September 30, 2002)

Synopsis

In this study, waste plastics were mixed with an asphalt mixture as a part of aggregates, and the application of waste plastics to a material of asphalt mixtures was researched from the effect of the mixed plastics on properties of the mixtures. Dense graded and porous asphalt mixtures were used in the experiment.

Polyethylene and polypropylene are more useful than any other kinds of plastics. So, Plastics used in the experiment were polyethylene and polypropylene pellets sold at market, polyethylene recycled pellets made from PET bottle labels, crushed polyethylene in industrial wastes and mixed plastics in domestic wastes.

The results indicated fluidity-resistant of dense graded asphalt mixtures is improved by mixed with polyethylene or polypropylene, and bending fatigue destruction-resistant and anti-stripping of dense graded asphalt mixtures are improved by mixed with polyethylene. Fluidity-resistant, oil-resistant and anti-stripping of porous asphalt mixtures are improved by mixed with polyethylene.

KEYWORDS: Waste plastics, Dense graded asphalt mixture, Porous asphalt mixture, Fluidity-resistant, Bending fatigue destruction-resistant, anti-stripping, Oil-resistant

Introduction

Plastics are light, durable, transparent, and insulated, and does not pass water and oxygen. So plastics have prominent properties and are used by various ways needing those properties. Production and consumption of plastics are being increased. Discharge of waste plastics is being increased too. It is about two times as many as that of ten years ago in Japan.

The ratio of recycled of waste plastics for thermal energy by incineration, solid fuel, oil, and so on is about 50 percent. It is lower than that of glass bottles, canned aluminum and canned steel. The other 50 percent is only destroyed by fire and filled up. It is need to suggest a new reuse method because calorific value by incineration is high and the filled up ground is lacking.

Objectives

In this study, an effective recycle method of waste plastics and a method for improvement of the properties of asphalt mixtures were researched by using plastics as a part of aggregates in asphalt mixtures.

Mixture types and plastic types

Asphalt Mixture Types

Asphalt mixtures types used in this study is shown in Table 1.

The binder of dense graded asphalt mixtures was used 60/80 penetration asphalt (ST60/80).

*Doctorial Candidate of Urban Eng.

**Professor, Department of Urban Eng.

Table 1. Asphalt Mixture Type

Sieve Size,mm	Dense Grade	Porous
19	100.0	100.0
13.2	97.5	95.0
9.5	85.8	71.0
4.75	62.5	23.0
2.36	42.5	15.0
1.18	30.8	13.0
0.6	26.3	11.0
0.3	15.5	9.0
0.15	11.0	7.0
0.075	6.0	5.0
Binder Content%	5.5	5.0
Binder Type	S T 60/80	HVMA
Vesitaable Fiber,(% Aggregates weigt)	—	0.3

Asphalt content was 5.5%. The binder of porous asphalt mixtures was used high-viscosity-modified asphalt (HVMA). Asphalt content was 5.0%. All mixtures were used crushed rocks of sandstone as coarse aggregates, crushed sands as fine aggregates and crushed powders of limestone as fillers.

Plastic Type

In Japan, the production of polyethylene is about 24.2% and that of polypropylene is about 19.8% in total production of plastics. Productions of them are about 44% in total production of plastics. Accordingly, five types plastics were used in this study (Table 2).

- 1) Polyethylene pellet sold at market (PE-1).
- 2) Crushed polyethylene in industrial wastes (PE-2).
- 3) Polyethylene pellet made from PET bottle labels (PE-3).
- 4) Polypropylene pellet sold at market (PP).
- 5) Mixed plastic in domestic wastes (WP-1).

Table 2. Plastic Type

Type	Polypropylene	Polyethylene			Waste Plastic
	PP	PE-1	PE-2	PE-3	WP-1
SieveSize,mm	Pellet sold at a market	Pellet sold at a market	Industrial Waste	Pellet Made from PET Bottle Labels	Domestic Waste
19	—	—	100.0	—	—
13.2	—	—	98.7	—	—
9.5	—	—	14.6	100.0	100.0
4.75	100.0	100.0	0.8	91.3	86.9
2.36	0.0	0.0	0.1	43.9	14.0
1.18	—	—	—	10.8	5.0
0.6	—	—	—	1.4	1.8
0.3	—	—	—	0.1	0.1
Shpe	Globe	globe	Rubble	Grain	Rubble
Specific Gravity	0.921	0.900	0.900*	0.900*	0.900*

(* Average)

These plastics were replaced aggregates of same volume. PP, PE-1 and WP-1 replaced 4.75-2.36(mm) sieve size aggregates. PE-2 replaced 9.5-4.75(mm) sieve size aggregates. PE-3 replaced 0.6-0.075(mm) sieve size aggregates.

Experiments

The following experiments were done to compare asphalt mixtures mixed with plastics with the plain asphalt mixture. And effects on mixing the plastics were researched by these results.

Wheel Tracking Test

Wheel tracking test was carried out to research the fluidity-resistant of asphalt mixtures. The wheel load was 686kN. The tracking velocity was 42 passed per a minute. Dynamic Stability (DS) of asphalt mixtures was researched by this method.

Immersion Wheel Tracking Test

Immersion wheel tracking test was carried out by the following methods to accelerate stripping. The tracking velocity was 84 passed per a minute. A filter paper was set on the bottom of the asphalt mixture-specimen (thickness, 4mm). A water level was 5mm in case of the dense graded mixture specimen and 20mm in case of the porous mixture from the bottom of specimen (Figure 1).

The Wheel tracked and the curve of Subsidence-Time was indicated like Figure 2. The failure time was defined the time at the most inflectional point in the curve. The failure time is an index of stripping.

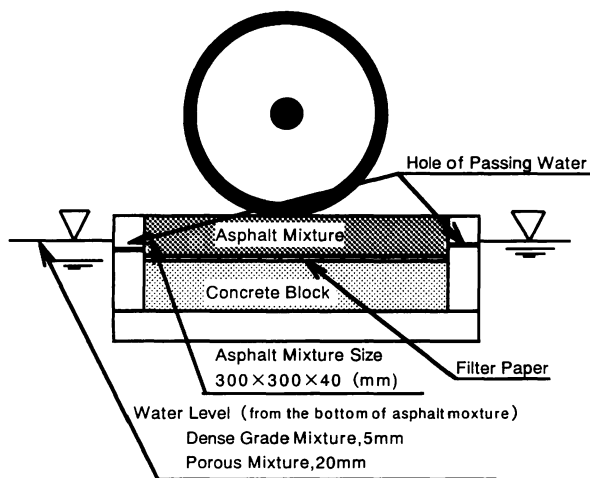

Figure 1. Immersion Wheel Tracking Test

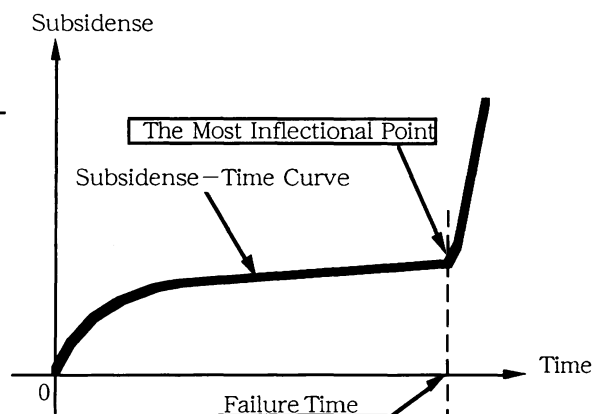

Figure 2. Definition of Failure Time

Bending Fatigue Test

In dense graded asphalt mixtures, bending fatigue test specimens were prepared by cutting 30mm wide, 30mm height, and 300mm length. Both sides were born and the span was 240mm. The center of specimen was given 0.25mm amplitude and 1Hz frequency of sine wave. The temperature during the test was 10°C.

The force and deflection were measured to calculate the stress and strain. The ratio of maximum stress and maximum strain is stiffness.

The bending fatigue destruction number defined: the number N , $S_N=0.5S_{10}$
 (S_{10} : The stiffness of tenth cycles, S_N : The stiffness of N th cycles).

Oil-Resistant Test

When oil dropped from cars permeated porous asphalt mixtures, the cohesion of asphalt. Pot-hole in pavement seem to be occurred by this process, mainly.

So, oil-resistant of porous asphalt mixtures was researched by the following method.

1. A specimen of Marshall test was prepared.
2. The specimen was immersed in gasoline from top to bottom. The immersion time was 3minutes, 5minutes and 10minutes.
3. Then the specimen was taken out.
4. Marshall stability was measured and retained stability was measured by compared with Marshall stability of immersed in gasoline and that of not immersed in it.

Results

Results of experiments are indicated at the following by divided dense graded asphalt mixtures and porous asphalt mixtures.

Results of Dense Graded Asphalt Mixtures Mixed with Plastics

Wheel Tracking Test

Plastics were mixed 10% volume of the dense graded asphalt mixture. The mixture was made on 150°C and mixed for two-half minutes in hot mixer.

Table 3 shows Dynamic Stability (DS) of mixtures mixed with plastics. It is indicated DS of dense graded asphalt mixtures was increased by mixed with all plastics used in this study. But the degree of increase was differed by plastic types.

**Table 3. Results of Wheel Tracking Test
 (Dense Graded Asphalt Mixtures Mixed with Plastics)**

Mixed Plastic	DS (pass/mm)
No Plastic	580
PP	3940
PE-1	2860
PE-2	16600
PE-3	21000
WP-1	700

Bending Fatigue Test

DS was changed by volume of plastics and time of hot mixing and the influence of property of bending fatigue destruction was researched in these cases (Figure 3).

Figure 3 shows that DS was increased, but bending fatigue destruction number was not increased by mixed with PP. It is indicated that fluidity-resistant is improved and bending fatigue destruction-resistant is not improved by mixed with PP, PP melts under the heated condition.

On the other hand, in the case of mixtures mixed with polyethylene (PE-1, PE-2, PE-3), the more increased DS, the more increased the bending fatigue destruction number- improved

property of bending fatigue destruction-resistant.

Mixtures mixed with WP-1 was increased DS, but the bending fatigue destruction number is not so alike PP. It is presumed WP-1 was included many polypropylene in its rate.

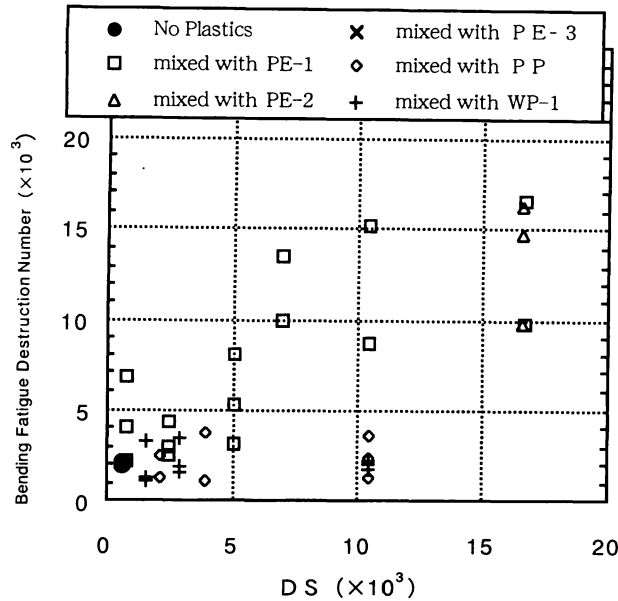

Figure 3. The Bending Fatigue Destruction Number vs DS (Dense Graded Asphalt Mixtures Mixed with Plastics)

Immersion Wheel Tracking Test

Table 4 shows DS and the destruction time in Immersion wheel tracking test. In the case of mixtures mixed with polyethylene, the more increased DS, the more prolonged the failure time.

But mixtures mixed with PP and WP-1 were not prolonged the destruction time against increased DS.

Table 4. DS and Failure Time

Mixed Plastics	DS (pass/mm)	Failure Time (minutes)
No Plastics	580	130
PP	10500	150
PE-1	700	630
PE-2	16600	1500 over
PE-3	21000	1500 over
WP-1	10500	140

Summary of Results of Experiments: Dense Graded Asphalt Mixtures Mixed with Plastics

In case of dense graded asphalt mixtures mixed with plastics used in this study, Fluidity-resistant was improved by melted under the heated condition. But mixtures mixed with PP were

not improved properties of bending fatigue destruction and stripping-resistant.

Mixtures mixed with polyethylene were improved those all properties. The reason is polyethylene has viscosity when it is melted under the heated condition. But it was shown roughness of the surface of mixtures was occurred by this property.

Results of Porous Asphalt Mixtures Mixed with Plastics

Porous asphalt mixtures have high fluidity-resistant because of used high-viscosity-modified asphalt. For these grading, there is need to keep or improve water-resistant qualities. So, plastics mixed in porous asphalt mixtures were PE-2 and PE-3 that were improved properties of bending fatigue destruction and stripping-resistant of dense graded asphalt mixtures.

Wheel Tracking Test

Plastics were mixed 0-10% volume of the porous asphalt mixture. The mixture was made on 170°C and mixed for two-half minutes in hot mixer.

Table 5 shows Dynamic Stability (DS) of porous asphalt mixtures mixed with plastics. It is indicated that DS of porous asphalt mixtures was increased by mixed with all plastics used in this study. But the rate of increase was smaller than dense graded asphalt mixtures because porous mixtures without plastics have high DS.

Table 5. Results of Wheel Tracking Test (Porous Asphalt Mixtures Mixed with Plastics)

Mixed Plastics	Volume of mixed (%)	DS (pass/mm)
No Plastics	—	6300
PE-2	8	10500
PE-3	6	10500

Immersion Wheel Tracking Test

Figure 4 shows the failure time in Immersion wheel tracking test. Figure 4 indicated that

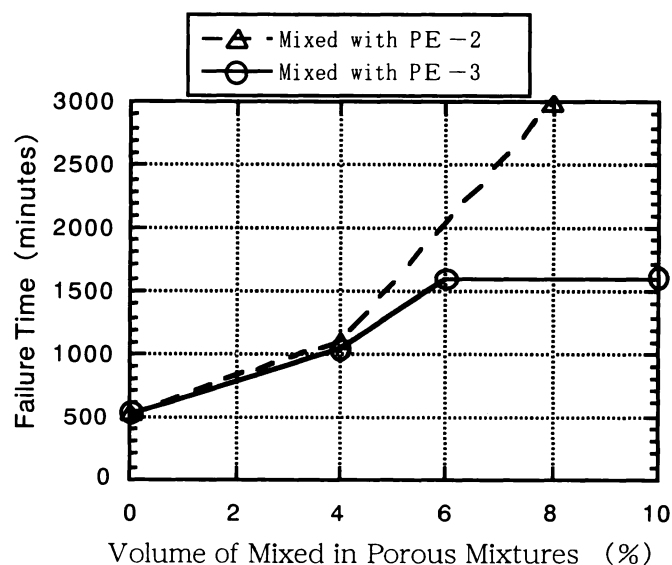

Figure 4. Failure Time vs Volume of Mixed in Porous Mixtures (Porous Asphalt Mixtures Mixed with Plastics)

porous asphalt mixtures mixed with PE-2 and PE-3 were prolonged failure time. Alike the case of dense graded asphalt mixtures, it is presumed that polyethylene gets viscosity at the time of melted under the heated condition gives the effect for bonded aggregates and binder.

Oil-Resistant Test

Figure 5 shows the results of oil-resistant test. Immersed gasoline in ten minutes, PE-3 mixed 6% volume had about 65% and PE-2 mixed 8% volume had about 85% against about 40% of the mixture without plastics.

Porous asphalt mixtures are improved the property of oil-resistant because polyethylene has the property of oil-resistant and coated mixtures by melt in heat.

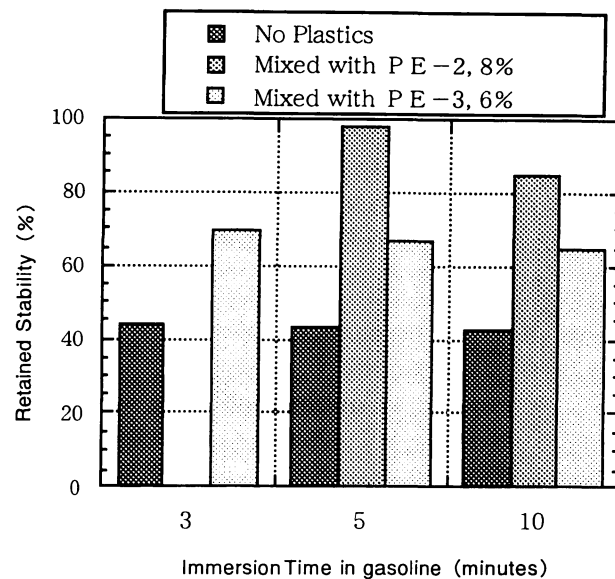

Figure 5. Retained Stability vs Immersion Time in Gasoline (Porous Asphalt Mixtures Mixed with Plastics)

The Observation of Surface of Porous Asphalt Mixtures Mixed with Plastics

It is anxious that porous asphalt mixtures mixed with polyethylene were adhered on roller and occurred roughness of the surface by viscosity at the time of melted under the heated condition. Especially in porous asphalt mixtures, it may cause porous mixtures serious damage for its needed properties.

So method of on-site test for water permeability of porous asphalt mixture was carried out and the volume of permeable by water was researched. The results indicated that it was not effect for volume of permeable by water and air void to be mixed with PE-2 and PE-3.

But it was found that there were many filled up voids and roughness on the surface of porous mixtures mixed with PE-2 (Figure 6). It is presumed that PE-2 fills up voids of surface of the mixture and adheres roller with coarse aggregates because it is large size and becomes a large viscous clod by melted in heat. On the other hand, porous asphalt mixtures mixed with PE-3 did not occur roughness of the surface. It is presumed that PE-3 is small size and does not become a large viscous cloud.

Summary of Results of Experiments: Porous Asphalt Mixtures Mixed with Plastics

It is suggested that porous asphalt mixture is improved fluidity-resistant, stripping-resistant (water-resistant) and oil-resistant by mixed with PE-2 and PE-3. But it is anxious that mixture

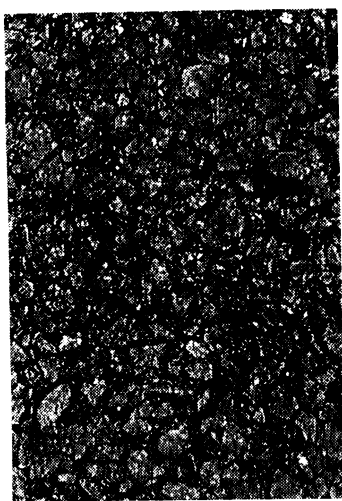

Mixed without Plastics

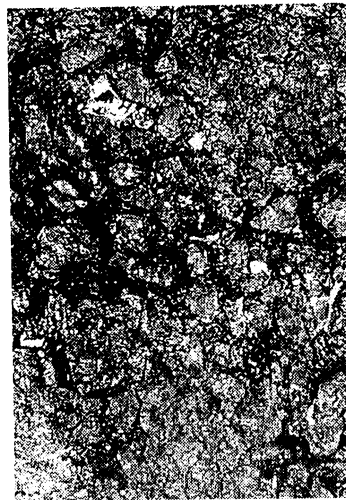

Mixed with PE-2

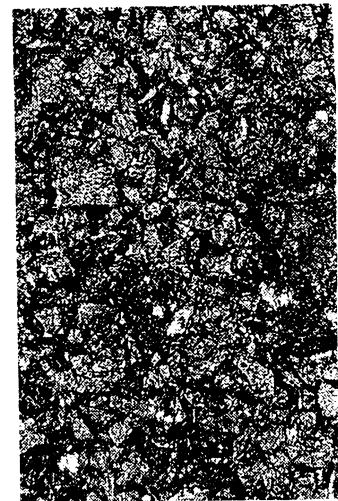

Mixed with PE-3

Figure 6. Surfaces of Porous Asphalt Mixtures

mixed with PE-2 becomes roughness on the surface.

Conclusion

The following facts are found in this study.

1. The fluidity-resistant of dense graded asphalt mixtures is improved by mixed with polypropylene.
2. The fluidity-resistant, bending fatigue destruction-resistant and stripping-resistant of dense graded asphalt mixtures are improved by mixed with polyethylene. But it is anxious that it is adhered on the surface of roller by the viscosity of polyethylene melted under the heated condition.
3. The fluidity-resistant, bending fatigue destruction-resistant and stripping-resistant of porous asphalt mixtures are improved by mixed with polyethylene. The surface of mixtures is roughness by polyethylene of large size. But mixtures mixed with polyethylene of small size is not adhered the roller and filled up the voids of surface.

These results were indicated that utilization of waste plastics in asphalt mixtures is possible and the property of mixtures is improved under a condition of method of mixing plastics and type of it. But there are various types of waste plastics. It is need the study of possibility of utilization of various types of waste plastics in asphalt mixtures is continued.