

## Evaluating Skin Condition Using Cosmetics by Image Processing of Cheek Replica

Yukie HASHIMOTO\*, Yoshio YANAGIHARA\*\*, and Hiromitsu HAMA\*\*\*

(Received October 15, 2002)

### Synopsis

In this paper, we describe a system for evaluating skin condition about the shape of cheek surface replica by using cosmetics. Various characteristics of skin surface are inspected. The shape of the skin surface provides much information, and then it is very significant to extract features from the skin surface. In this system, we examine the rate of high frequency components from cheek replica images, and we confirm which foundations give fine texture of skin. There are four types of foundations, namely, facial cake, powder and liquid. Extracting the high frequency components, the effect of the system is demonstrated.

**KEYWORDS:** evaluation of skin condition, image processing, high frequency components, cheek replica image

### 1. Introduction

There are many choices of cosmetics products. So, it is very desirable to show the effect of cosmetics and to develop the way to evaluate objectively human skin surface condition. From consumers viewpoint, cosmetics can be bought easily in the store but they want to know immediately that it is fit for their own skin. At its moment, the features of human skin surface condition must be extracted by a certain way. The evaluating system for human skin surface condition by using image processing is very effective.

To show the effect of cosmetics, various features of skin surface, such as shape, color, and moisture, should be inspected. The shape of skin surface provides much information, for example, the age and the quality of the skin, and so on. It is very significant to extract feature from the shape of the skin surface. In general, skin surface replicas are used for the inspection of the skin surface shape. The skin surface replicas are composed of rubber which is formed on the skin surface, and then the rubber surface becomes the reverse shape of it. Since the required resolution of the skin surface shape measurement is almost the order of micro millimeter, it is difficult to obtain 3D shape by applying general 3D shape measurement techniques such as light interference method. Therefore, the shape features are implicitly inspected by analyzing 2D microscope images.

In this paper, we describe a system for evaluating skin condition about the shape of cheek surface replica by using cosmetics. We express the rate of high frequency components from cheek replica images, and we confirm which foundations give fine texture of skin. We use four types of cosmetics, which namely cream, facial cake, powder, and liquid. To extract the high frequency component, the effect of the system is demonstrated.

### 2. Image Features

In this system, we express the rate of high frequency components from cheek replica images. This image feature is the standard to measure fine-texture of skin. This pattern is composed of the skin ditch that spread vertically, horizontally, diagonally and the skin hill separated by it. The skin ditch and hill become indistinct. From the viewpoint of this tendency, the skin ditch, called, high frequency components, is extracted by threshold operation is performed. The results are shown in **Fig.1** and **Fig.2**. The rate of white pixels are calculated from the whole pixels of the image feature as shown in **Fig.3**. The more the skin ditch is outstanding, the more this image feature show large value.

---

\* Student, Master Course of Department. of Physical Electronics and Informatics

\*\* Associate Professor, Department of Physical Electronics and Informatics

\*\*\* Professor, Department of Physical Electronics and Informatics

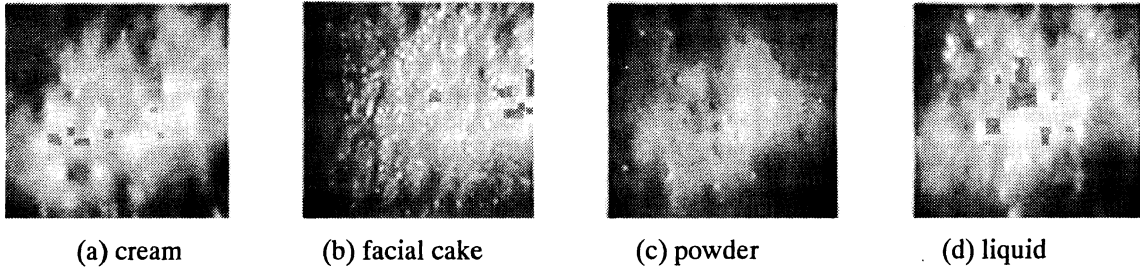

**Fig.1** Cheek replica images.

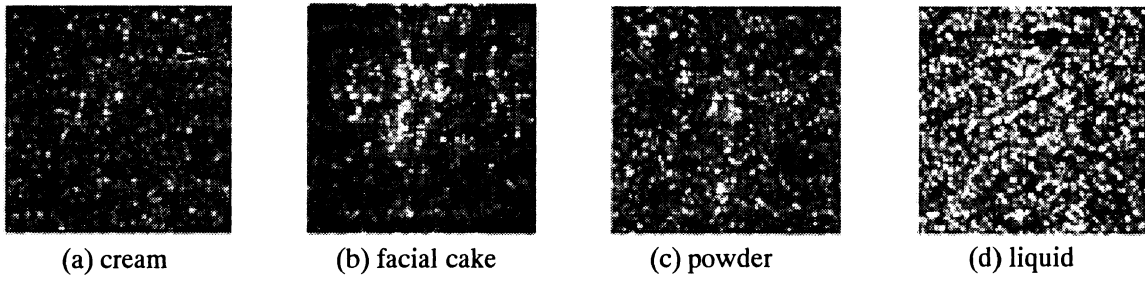

**Fig.2** High frequency components.

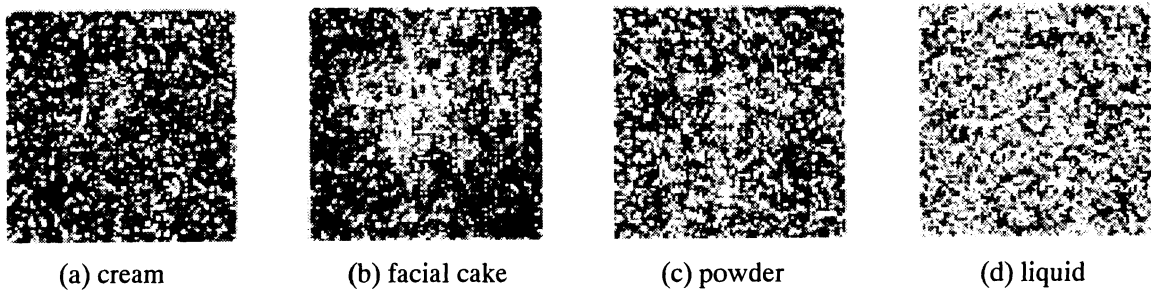

**Fig.3** Extracted images by threshold operation.

### 3. Experiments

This system is implemented by using Matlab programming Ver 6.0 on a Pentium III computer. We use USB microscope as shown in Fig.4. When the object is taken from the camera, the LED illuminator is placed 45 degrees inclination with the camera position. An image taken from this microscope is shown in Fig.5. In Fig.6, we can easily see the plain paper copier that showed the average value of brightness. This figure describes a solid line for a row pixel and broken line for a column pixel, respectively. The standard deviation of all pixels is 0.0013. We can use the microscope even light illumination.

The skin images are shown in Fig.1 ((a) cream, (b) facial cake, (c) powder, and (d) liquid type)). These skin images are taken from the part of cheek by using USB microscope. These images are applied for four types of foundation to human face. Each image sizes 160x160 pixels.

**Table1** Rate of high frequency components.

(a) cream foundation	0.3212
(b) facial cake	0.3764
(c) powder foundation	0.4644
(d) liquid foundation	0.7087

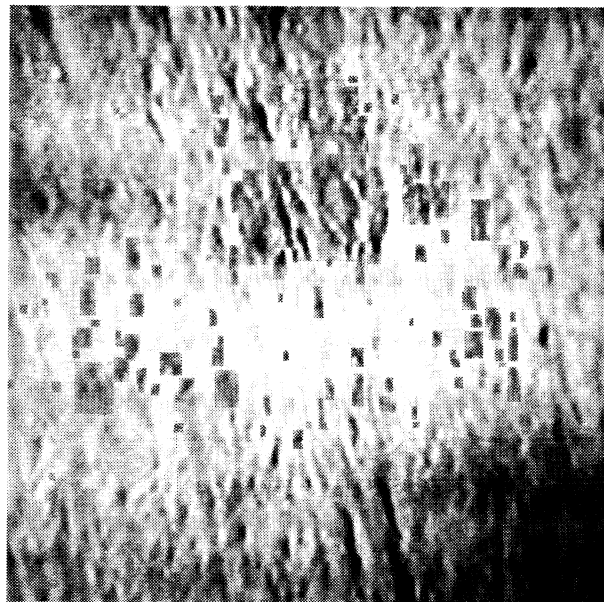

**Fig.4** Microscope image.

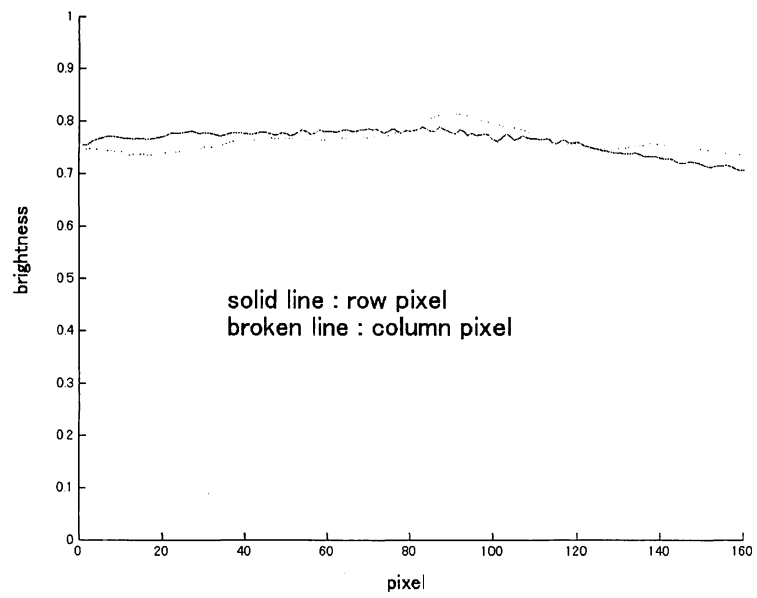

**Fig.5** Average value of brightness.

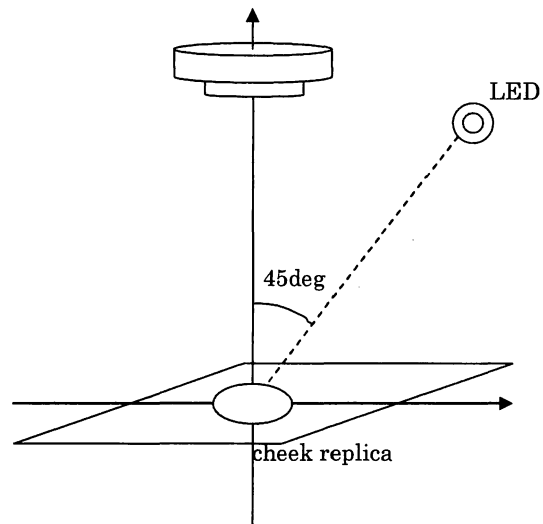

**Fig.6** Scheme of microscope.

#### 4. Results

To evaluate four types of foundation's skin condition, we considered the rate of high frequency component. **Table1** shows the results of four types of foundation. We can confirm which foundation gave fine texture of skin by calculating the rate of high frequency component. The largest value is the liquid foundation, so it unlikely possibility to correction. The value of facial cake is small as shown in **Fig.5(b)**. It is difficult to put on makeup un-curved skin surface by facial cake, although it shows promising correction action. The cream foundation is the most cling tightly. Moreover, it can be smoothed evenly over face.

#### 5. Discussion

In this system, we considered only two dimensional evaluation using four types of foundations. Moreover, there are many beneficial effects on the evaluation of human skin by using three dimensions . In future, we will derive the reconstruction of human skin surface by using three dimensional evaluation.

#### References

- 1) Y.Takemae, H.Saito,and S.Ozawa, "The evaluating system of human skin surface condition by image processing" , IEEE International Conference on Systems, Man, and Cybernetics, pp.8-11, 2000.
- 2) K.Shimoto, T.Honda and S.Kaneko, "A Formalization of Photometric Stereo Method Using Two Light Sources and Its Application to Reconstruction of Human Skin Replicas" ,TRANS.IEICE, VOL.J82-D-II, no.1, pp.10-18, 1999.
- 3) R.J.woodham, "Photometric method for determinating surface orientation from multiple images" , OPTICAL ENGINEERING , Vol.19, pp.139-144, 1980.
- 4) S.R.Marschner, S.H.Westin, E.P.F.Lafortune,and D.P.Greenberg, "Reflectance Measurements of Human" , PCG, 1999.
- 5) Y.Takemae, H.Saito, and S.Ozawa, "3D Reconstruction of Skin Surface from Image Sequence" , IEICE TRANS.INF.& SYST., VOL.E83-D, NO.7, 2000.