

A methodology for evaluating the controllability of a ship navigating in a restricted channel

K. ELOOT^A, J. VERWILLIGEN^B AND M. VANTORRE^B

^AFlanders Hydraulics Research (FHR), Flemish Government, Antwerp, Belgium

^BMaritime Technology Division, Ghent University, Ghent, Belgium

A methodology is presented for evaluating the controllability of a ship navigating in a restricted channel by means of a hydrodynamic force analysis. This method is applied to assess the controllability of a container vessel in straight channel reaches and in bends in two practical cases. By comparing different initial conditions and bottom configurations the influence of different ship characteristics (main dimensions, draft, rudder and propeller characteristics), operational parameters (such as speed, propeller commands, and bank clearance), environmental parameters (such as current and tidal level), and channel characteristics (water depth, bank slope, bend radius) on this controllability can be evaluated. For estimating the components of the force analysis, use is made of results of captive model tests in shallow and restricted waters.

Keywords: Controllability of a ship, bank effects, structural and operational measures.

1. Introduction

Manoeuvring simulation, either controlled by an autopilot (fast time) or by a human operator (real time), is an approved tool for evaluating the feasibility and safety of ship manoeuvres and transits. In both control modes, the characteristics and quality of the controller may considerably affect the results and conclusions of the simulation study. On the other hand, regardless of the control system, it is impossible to keep the ship under control if the available control forces generated by the rudder are exceeded by the forces disturbing the ship (e.g. bank effects, current) or required to perform a given trajectory (e.g. bends). Due to inertia, a temporary unbalance (e.g. due to wind gusts, meetings, ...) may be acceptable in particular cases, but a permanent exceeding of the control forces inevitably results into an uncontrollable ship.

In order to evaluate the inherent safety of a considered manoeuvre, a methodology can be used for comparing the available control forces with the forces that have to be counteracted. This hydrodynamic force analysis will only take yawing moments into consideration. This methodology can be applied to determine operational limits, to investigate the sensitivity of ship controllability with respect to parameter variations, and to compare existing situations to new conditions.

With respect to parameter variations, generally a large number of parameters affecting a manoeuvre can be identified. In the case of a ship taking a bend in a river with longitudinal current, following non-exhaustive distinction can be made:

- ship dependent characteristics such as draft, geometric dimensions (scale factor), and manoeuvring behaviour;
- environmental parameters such as water depth variations, current and tide;
- channel characteristics such as bank geometry, water depth and bend radius;
- operational parameters such as propeller rate, ship speed and bank clearance.

In this paper two situations will be considered based on practical case studies. Firstly, a ship navigating in a canal, following a straight course parallel to the centre line will be considered, which is typically the case in a two-way traffic situation. As a second example, the force balance for a ship taking a bend to starboard on an eccentric course on a river will be investigated.

2. Hydrodynamic Forces

2.1. Control forces

If external forces (e.g. exerted by tugs) are not taken into account, the available control forces are supplied by the rudder. If available, a full mathematical manoeuvring simulation model for the considered vessel can be used; however, a first approximation can be obtained by using following formula for the lateral force Y_R and the yawing moment N_R at the rudder:

$$Y_R = \frac{1}{2} \rho C_{YR} u_R^2 A_{RT} \quad (1)$$

$$N_R = -\frac{L_{pp}}{2} Y_R \quad (2)$$

The flow at the rudder is visualised in Fig. 1 and depends particularly on the forward ship speed u and the thrust loading coefficient C_{Th} .

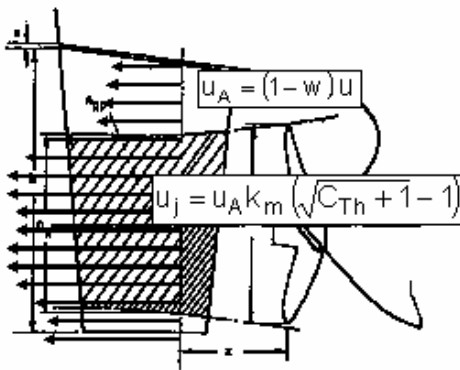

Fig. 1. Flow at the rudder

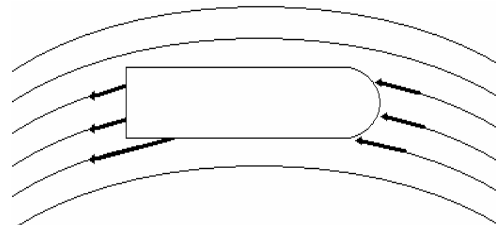

Fig. 2. Yawing moment caused by the curvature of the streamlines of the longitudinal current

2.2. Curvature of the current

The current in a bend is assumed to follow the curvature of the waterway. Consequently, a ship taking a bend will be subject to a yawing moment N_C caused by the different flow orientation at the stern and the bow (Fig. 2), that can be calculated by means of:

$$N_C = (N_{ur} - mx_G)u \frac{V_C}{R} \quad (3)$$

N_{ur} being the linear yaw velocity hydrodynamic coefficient for the yaw moment, which depends on the water depth to draft ratio. When a ship takes a bend to starboard the current will cause a yaw moment to port side when the when the ship is sailing upstream.

2.3. Bank effects

In general, a ship following a course parallel to a bank will be subject to a lateral force towards the nearest bank, and a yawing moment that tends to turn the ship towards the centre line of the waterway.

This effect is caused by an asymmetric flow due to the ship speed and the action of the propeller. If the flow due to ship speed is isolated, however, the lateral force may be repulsive if the under keel clearance is very small (e.g. 10% of draft). The yawing moment, on the other hand, always acts in the same sense, but is also very sensitive to water depth changes. Propeller action always causes a lateral force aft acting towards the bank.

Because the yawing moment generated by the bank always acts towards the centre of the waterway, and a ship normally sails at the starboard side of this waterway, the bank will hinder a bend to starboard.

For the estimation of the yawing moment induced by a bank, a regression model described in [1] has been applied. The yawing moment N_{bank} is subdivided into three contributions: $N^{(H)}$ due to the ship speed (pure towing condition), $N^{(P)}$ due to the propeller loading (bollard pull condition), and $N^{(HP)}$ due to a combination of ship speed and propeller loading:

$$N^{(H)} = \frac{1}{2} \rho L^2 T u^2 \sum_{i=1}^2 \sum_{k=0}^2 \beta_{ik}^{(H)} y_B^i \left(\frac{T}{h_{eff} - T} \right)^k \quad (4)$$

$$N^{(P)} = \frac{1}{2} \rho L^2 T V_T^2 \sum_{i=1}^2 \sum_{k=0}^2 \beta_{ik}^{(P)} y_B^i \left(\frac{T}{h_{eff} - T} \right)^k \quad (5)$$

$$N^{(HP)} = \frac{1}{2} \rho L^2 T V_T^2 Fr \sum_{i=1}^2 \sum_{k=0}^2 \beta_{ik}^{(HP)} y_B^i \left(\frac{T}{h_{eff} - T} \right)^k \quad (6)$$

The effective water depth h_{eff} is calculated accounting for the mean sinkage z_m :

$$h_{\text{eff}} = h - z_m \quad (7)$$

with

$$z_m = T \left[c_1 + c_2 \left(\frac{n}{n_{\text{max}}} \right)^2 + c_3 y_B + c_4 \left(\frac{n}{n_{\text{max}}} \right)^2 y_B \right] \frac{Fr_h^2}{\sqrt{1 - Fr_h^2}} \quad (8)$$

The coefficients c_i and β_{ik} in these formulas are deduced from comprehensive captive model test programs, carried out in the *Towing tank for manoeuvres in shallow water (co-operation FHR – Ghent University)* in Antwerp, with a ship loaded within a range of drafts interacting with different banks, [2], [3]. The bank configurations differ in slope, water depth, and the level of a horizontal submerged bank.

2.4. Bend initiation

Based on the results of (simulated) turning circle manoeuvres, an estimation can be made of the fraction of the available rudder capacity required to perform a bend with given characteristics (i.e. radius), taking account of the ship's forward initial speed and the propeller rate. Although these two parameters are not fully independent, for bend initiation they can be considered as such in practice.

The present calculations will be based on captive manoeuvring test series carried out at FHR with container carrier models at different drafts and under keel clearances [4], [5]; typical results are shown in Fig. 3. As deep water conditions were not tested, the model may be less reliable at large under keel clearances. In deep water, the manoeuvring performance of the vessel in Fig. 3 is rather poor compared to the IMO standards, which results in conservative conclusions.

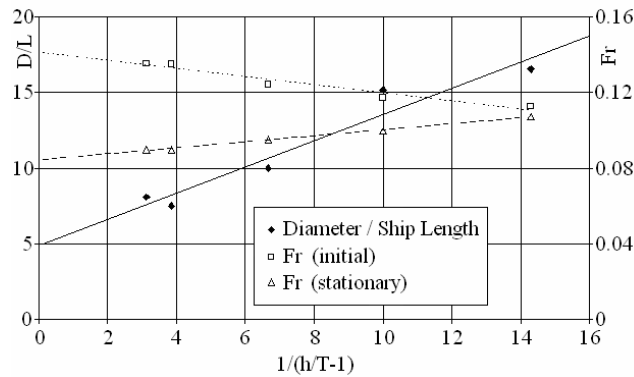

Fig. 3. Turning circle characteristics in function of under keel clearance for a container carrier model

3. Approach to a meeting in a straight reach of a two-way traffic channel

Before a meeting situation in a restricted channel, the vessels are lined up along their meeting lines, and are therefore subject to bank effects. For a specific ship in a given loading condition with a specified under keel clearance, the rudder angle required to compensate for bank induced forces depends on the ship speed, the applied propeller rate and the ship-bank distance. Graphs are generated for a specified engine setting, indicating zones of required rudder capacity as a function of speed and bank clearance.

As an example, a typical panamax container carrier meeting another ship in the Gaillard Cut, the narrowest reach of the Panama Canal, is discussed. At this location a ship preparing for a meeting situation will leave a clearance of about 1.5 times the ship beam to the buoy line (see Fig. 4).

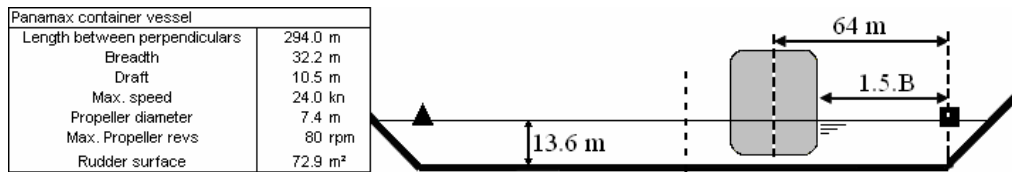

Fig. 4. Panamax container vessel sailing on her meeting line in the Gaillard Cut

In Fig. 5 the influence of the propeller rate on the controllability of a ship is illustrated. It can be concluded that the ship, sailing on her meeting line with a speed of 6.5 knots requires 38% of the rudder capacity to counteract the bank effects with propulsion slow, increasing to 70% at dead slow, and 85% with the propeller stopped.

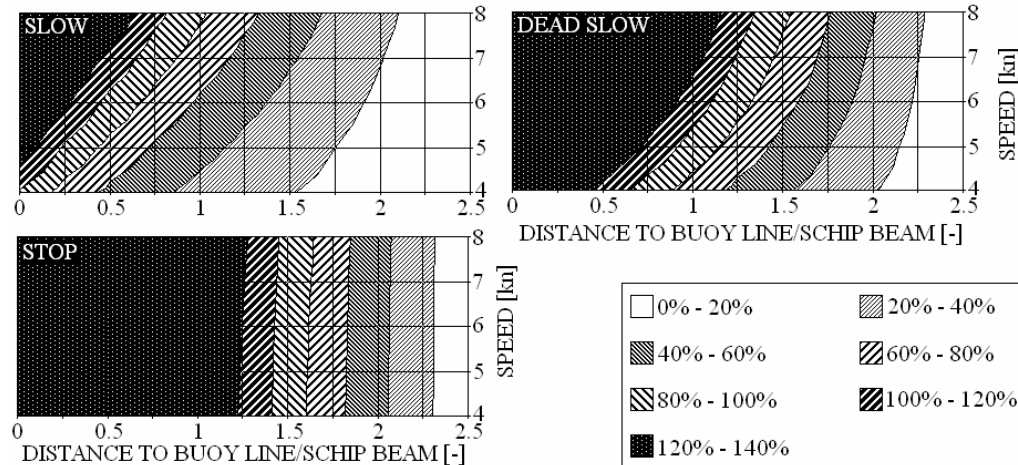

Fig. 5. Required rudder capacity at different propeller rates

In Fig. 6 the initial situation is compared with an enhanced situation after deepening of the channel. For a ship with engine slow ahead, the required rudder

capacity drops from 38% to about 25% if the depth is increased to 14.6 m. This can be explained by the fact that bank induced forces are very sensitive to under keel clearance variations.

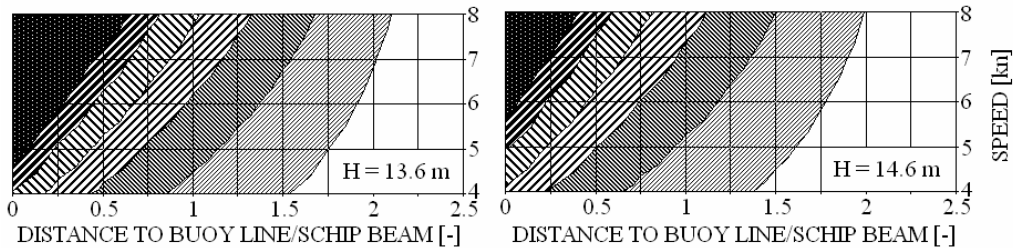

Fig. 6. Required rudder capacity: effect of deepening

4. Bend initiation on a river

4.1. Situation

The Western Scheldt, the river connecting the Port of Antwerp to the North Sea over a distance of 63 km, is characterised by an important tidal regime. Presently, ships with a draft larger than 11.85 m – planned to be increased to 13.1 m in the near future – are tide dependent, and regulations limit the draft of the vessels as a function of overall length. The methodology described above has been applied to assess the effect of increasing dimensions of container carriers on the controllability of the vessels at several critical locations in the fairway. One of these locations is the bend of Bath (Fig. 7), combining a rather limited bend radius of 1200 m with a restricted width (350 m between the buoys) and thus a limited bank distance.

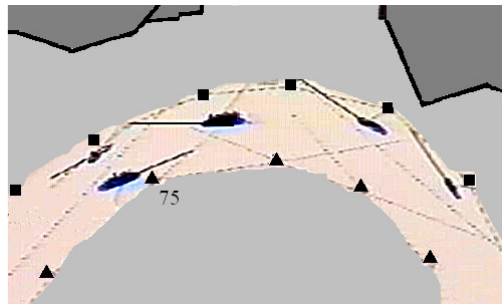

Fig. 7. Meeting situation in the bend of Bath

In order to initiate the bend successfully, the rudder capacity of the vessel, ascending the river, will have to counteract the influence of the ebb tide current and the banks, while a certain rudder capacity is also necessary for course changing and sailing along the bend. The influence of wind, which can nevertheless be important in this area, will be neglected in the following example.

The evaluation of the bend manoeuvre on the Western Scheldt is considered for a container carrier with dimensions as shown in Table 1. Moreover this table contains the reference situation for tide height, current velocity and bend radius.

Table 1. Reference situation: ship in arrival in bend of Bath

Tide height to MLLWS	1.16 m	Length over all	352.2 m
Current speed (ebb)	1.73 knots	Beam	42.8 m
Bend radius	1200 m	Draft	14.0 m
		Maximum speed	25.0 kn
		Propeller diameter	8.5 m
		Maximum propeller rate	104 rpm
		Rudder surface	83.1 m ²

In Fig. 8 the bathymetry is displayed monitored in 2005. The cross section is approximated by a bank with a slope of 1/8 investigated in the towing tank. At a certain distance the bottom becomes horizontal at a water depth equal to $h_1 = -2.0$ m referred to MLLWS. The effect of this submerged bank is discussed in [2].

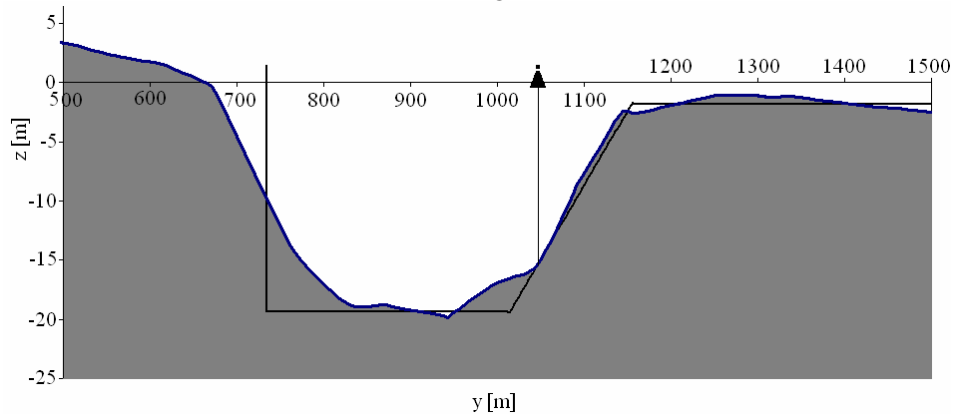

Fig. 8. Real (2005) and approximated bottom profile (water depth referred to MLLWS)

The required rudder capacity is displayed in Fig. 9. For example, a ship with speed through the water equal to 14 knots, propeller rate harbour full and leaving a clearance of 2 times the ship's beam to the buoy line, needs 66% of the rudder capacity to perform a bend and to counteract the effects of banks and current.

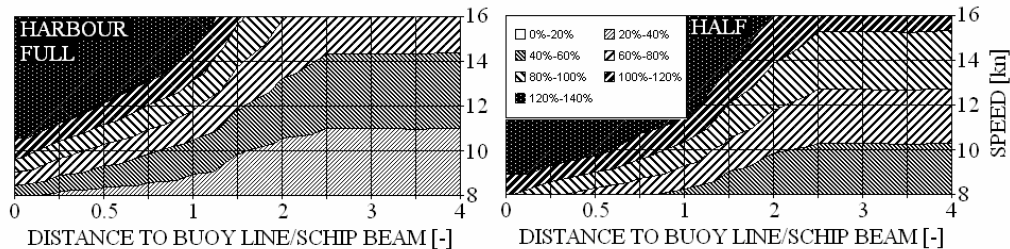

Fig. 9. Required rudder capacity at different propeller rates

4.2. Structural measures

The force balance methodology can be applied to assess the effectiveness of several possible structural measures that can be considered to improve the controllability of a ship in the situation described above. Preferably the structural measures can be accomplished by dredging outside the waterway, as in that case the dredging works do not hinder the shipping traffic. The following structural measures are considered (Fig. 10):

- Increasing the original bank slope (1/8) to steeper values (1/5–1/3);
- Increasing the level h_1 of the submerged bank from -2 m to -3 m;
- Dredging the toe of the bank.

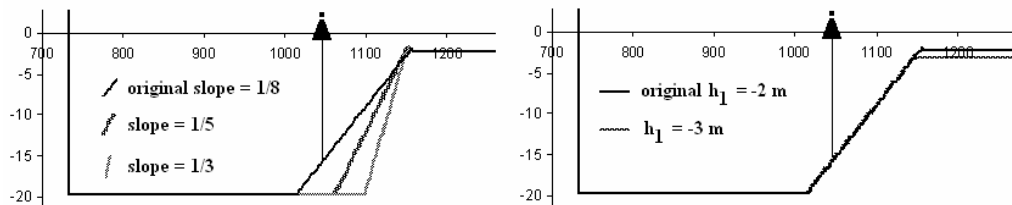

Fig. 10. Different bottom configurations to evaluate the influence of structural measures on the controllability of ships

4.2.1. Effect of steeper slopes

The results for the bottom configurations with different slopes sketched in Fig. 10, are shown in Fig. 11. At higher ship speeds the influence of a steeper slope is significant. The required rudder capacity for a ship at a speed of 14 knots, leaving a clearance of 2 times the ship's beam to the buoy line, drops from originally 66% to 63% for a slope of 1/5, and to 60% for a slope of 1/3.

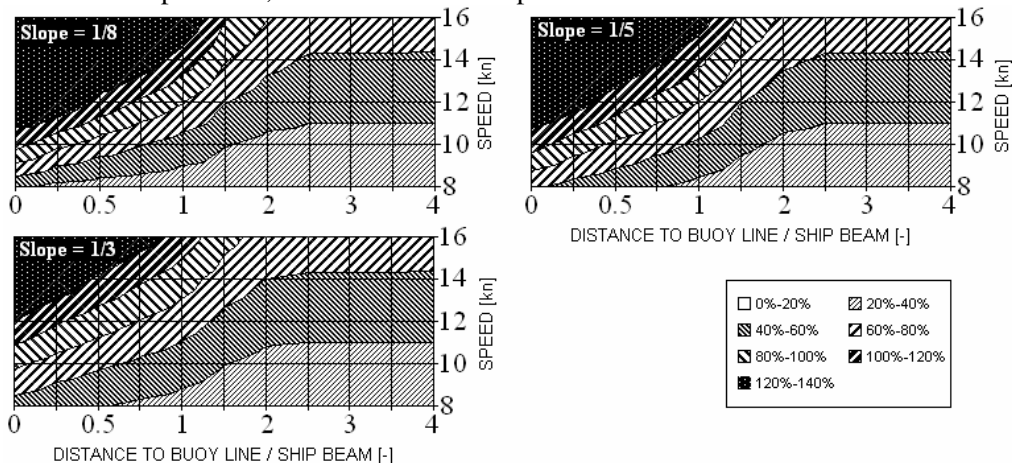

Fig. 11. Required rudder capacity at different slopes (harbour full)

Another way to evaluate the influence of steeper slopes is the comparison of the distances to the buoy line for which the ship, sailing at 14 knots, becomes incontrollable. Initially the ratio of the controllable distance to the buoy to the ship beam is 1.2. This value decreases to 1.1 for a slope of 1/5, and to 0.8 for a 1/3 slope.

4.2.2. Effect of a different h_1

The results for the bottom configurations with different h_1 sketched in Fig. 10, are shown in Fig. 12. The effect is negligible: after deepening the horizontal bank the required rudder capacity becomes 0.5% smaller for a ship with $V=14$ kn and $y_B/B=2$.

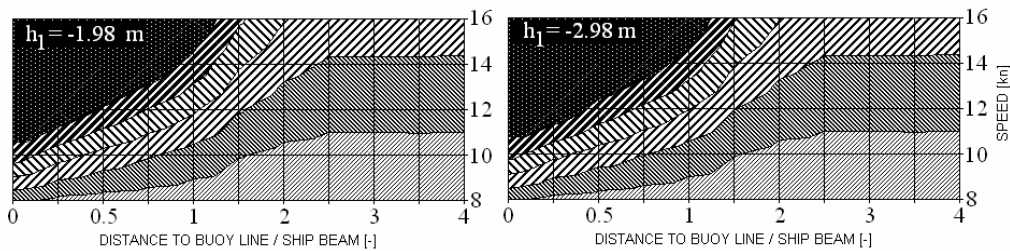

Fig 12. Required rudder capacity with different values of h_1 (harbour full)

4.2.3. Dredging the toe of the bank

Fig. 8 shows an accumulation of sediments at the toe of the starboard bank. In this case the required rudder capacity is shown for the same bottom as in Fig. 8, but the toe is dredged. From the evaluation in Fig. 13 it is clear that this modification positively influences the controllability of a ship sailing at a small distance to the buoy line, due to the increase of the local under keel clearance, which has an important effect on both manoeuvrability and bank effects.

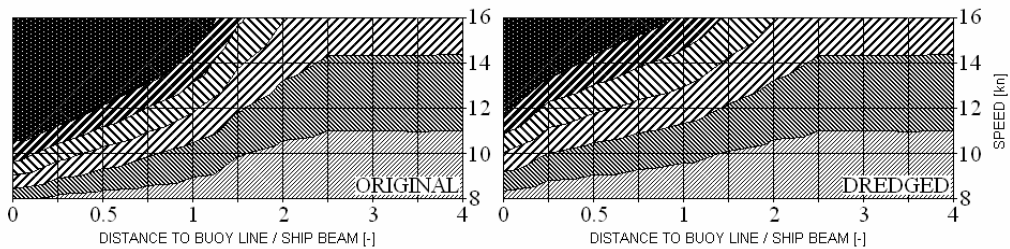

Fig. 13. Required rudder capacity with and without the toe at the starboard bank (harbour full)

4.3. Operational measures

Besides structural measures to improve the controllability, effective measures can also be taken by a conscious choice of different operational parameters such as ship speed, clearance to the buoy line, tide height, current speed and draft.

The effect of speed and clearance is clear from the previous figures. An increase of the ship speed and a decrease of the clearance to the bank will require a larger rudder capacity. Indeed, often only a moderate decrease of speed or a slight increase of the

bank clearance is required to obtain an effect that is comparable to the structural measures discussed above.

To evaluate the influence of tide height, current speed and draft, following variations of these parameters are examined:

- increase of tide height with 0.5 m (causing an increase of the under keel clearance);
- zero current speed;
- increase of draft with 0.5 m.

In Fig. 14 the required rudder capacities are shown for the reference conditions and the variations on these conditions as listed above. For a ship with $V=14$ kn and $y_B/B=2$ the required rudder capacity is outlined in Table 2.

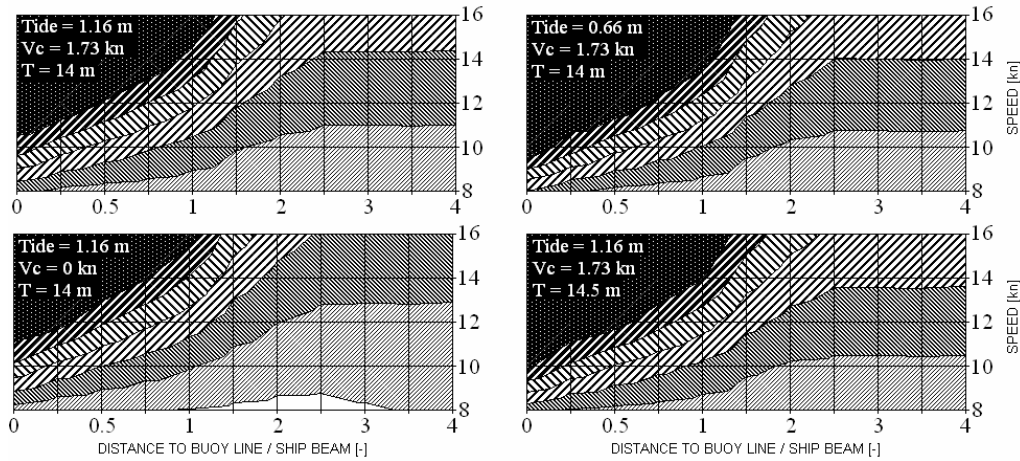

Fig 14. Required rudder capacity to evaluate operational measures

Table 2: Required rudder capacity for speed $V=14$ kn and bank clearance $y_B/B=2.0$

Draft (m)	14.0	14.0	14.0	14.5
Tide (m above MLLWS)	1.16	0.66	1.16	1.16
Current speed (kn)	1.73	1.73	0.00	1.73
Required rudder capacity	65.8%	69.8%	54.5%	70.9%

5. Conclusion

A hydrodynamic force analysis methodology has been presented, based on the comparison of the available control capacity that can be induced by the rudder and the yawing moments that are required to compensate for external disturbances such as bank and current effects or to initiate a defined bend. This method allows an evaluation of the effect of variations of the governing parameter on ship controllability, and may be used as a tool to compare new situations with known ones.

The influences of propeller rate, speed, bank clearance, under keel clearance, current velocity, and draft on the controllability of a ship in straight and curved

reaches of a channel have been illustrated. A comparison was made to evaluate possible structural and operational measures to improve the controllability of the ship in a bend.

Although this methodology may be very useful to provide a quantitative assessment of the feasibility of proposed manoeuvres, and to quantify the effect of certain measures on the controllability in a channel, one should keep in mind that a successful operation not only depends on the available rudder capacity, but also on dynamic effects, the swept path, interaction between ships, transit strategy, visibility, human factors, etc. In order to account for these elements, other tools such as fast time simulation and full mission bridge simulator runs are required. Nevertheless, the methodology described in this paper may give a useful indication.

6. Summary

The controllability of a ship can be evaluated by the comparison between the required yawing moment and the maximum yawing moment generated by the rudder. In this paper the method is illustrated by two manoeuvres. The first evaluation considers a ship sailing a straight course parallel to the canal centre line, the second evaluation handles a ship taking a bend to starboard on an eccentric course. In the first condition the ship is only subject to bank effects. A ship taking bends is further subject to the influence of the curvature of the current and requires a yawing moment to initiate the bend.

The proposed method offers an objective evaluation of the controllability of a ship. This evaluation can be used as a tool for fairway design or for defining traffic limits by calculating the beneficial effect of structural and operational measures on the controllability of ships.

The structural measures discussed in this paper are the influence of deepening, steeper slopes, deepening outside the waterway and dredging the bank toe. It can be concluded that dredging at the buoy line is much more effective than dredging outside the waterway.

Operational parameters investigated in this paper are ship speed, propeller rate, bank clearance, tide height, current speed and draft. In general, minor variations of ship speed and bank clearance may result into important effects on ship controllability. Also the under keel clearance, affecting both ship manoeuvrability and bank effects, appears to be a very important parameter.

7. Nomenclature

A_{RT}	lateral rudder area	(m ²)	N_R	yawing moment generated by the rudder	(Nm)
C_{YR}	non-dimensional lateral rudder force	(-)	N_C	moment generated by current	(Nm)
C_{Th}	thrust loading coefficient:		R	bend radius	(m)
	$C_{Th} = \frac{T_P}{\frac{1}{8} \rho \pi D_P^2 u_A^2}$	(-)	T	draft	(m)
D_P	propeller diameter	(m)	T_P	propeller thrust	(N)
Fr	ship length related Froude number	(-)	u	longitudinal ship speed	(m/s)
Fr_h	water depth related Froude number	(-)	u_A	advance speed at the propeller	(m/s)
h, H	water depth at the ship	(m)	u_R	average inflow velocity at the rudder	(m/s)
h_l	water depth outside waterway	(m)	V_C	current velocity	(m/s)
h_{eff}	effective water depth	(m)	V_T	reference speed in the propeller race	
k_m	propeller race contraction factor	(-)		$V_T = \sqrt{\frac{8T_P}{\rho \pi D_P^2}}$	(m/s)
L	ship length	(m)	w	wake fraction	(-)
L_{PP}	ship length between perpendiculars	(m)	x_G	longitudinal position of the centre of gravity	(m)
m	ship mass	(kg)	y_B	bank clearance	(m)
n	propeller rate	(rpm)	Y_R	lateral rudder force	(N)
n_{max}	reference propeller rate	(rpm)	z_m	mean sinkage	(m)
N_{ur}	hydrodynamic coefficient	(-)	β_{ik}	bank effect coefficients	(-)
			ρ	water density	(kg/m ³)

References

- [1] Vantorre M., Delefortrie G., Eloit K., Laforce E.: *Experimental investigation of ship-bank interaction forces*. International Conference on Marine Simulation and Ship Maneuverability (MARSIM 2003), Kanazawa, August 2003.
- [2] Lataire E., Vantorre M., Laforce E., Eloit K., Delefortrie G.: *Navigation in confined waters: influence of bank characteristics on ship-bank interaction*. International Conference on Marine Research and Transportation (ICMRT 2007), Naples, June 2007.
- [3] <http://www.bankeffects.ugent.be/>
- [4] Eloit K, Vantorre M., Delefortrie G.: *Prediction of ship manoeuvrability of an 8000 TEU containership in deep and shallow water: mathematical modelling and captive model testing*. International Conference on Marine Simulation and Ship Maneuverability (MARSIM 2006), Terschelling, June 2006.
- [5] Delefortrie G.: *Manoeuvring behaviour of container vessels in muddy navigation areas*. PhD Thesis, Ghent University, May 2007.