

## INTEGRATED SOLAR STILL SYSTEM FOR RINSE WATER FROM ZINC PLATING INDUSTRIES

P VEERAMANI, PR THANGAVELU, SM SILAIMANI, M RAGHAVAN AND S JOHN

*Central Electrochemical Research Institute, Karaikudi 630 006. INDIA*

(Received: 27 April 2000)

Accepted: 10 October 2000)

*Electroplating industries utilize huge quantities of water for preparing the processing solutions as well as for rinsing the parts. Due to environment board restriction on rinse water from plating plants, electroplating industries are facing considerable hardship as they have to spend lot of money for waste water treatment. The present study deals with the adoption of solar still for the treatment of wash water from zinc plating industries. It is possible to recycle the distilled water produced from the solar still and also the enriched zinc plating concentrate can be used to make up the electroplating bath as an integrated system.*

*Keywords: Electroplating*

### INTRODUCTION

Water is used in large quantities compared to any other chemicals in the plating shop. The purity required depends on the nature of the process being used. Generally electroplating industries are using distilled or deionised water for rinsing the job after the metal deposition. It has been estimated that 1 to 25 litres of rinse water is used each day for each litre of plating solution [1]. In acid zinc plating, the distilled or deionised water usage is slightly higher than the other plating works. At present this wash water is let out into municipal drainage or chemically treated. If this wash water is let out into the ground, that will spoil the ground water and is objectionable as per stipulations by the Pollution Control Board. For large acid zinc plating industries, the quantity of wash water is normally high and may be treated either chemically or economically by solar stills for recycling. D.I. water is required for make up of the acid zinc bath or rinsing operation normally [2]. D.I. water is produced by ion-exchange, reverse osmosis, electro dialysis and distillation process. Present energy crisis force to adopt non- conventional sources like usage of solar stills for the treatment of wash water from zinc plating industries.

### Physical and chemical treatment

Zinc in the waste water was reduced by ion exchange method or by heavy metal hydroxide precipitation via pH adjustment or by evaporation method [3-4].

Unfortunately ion exchange is not capable of producing a highly concentrated stream for recycle and it is difficult to optimise the split between the recovery metal salts and the water which is intolerable and the process is highly expensive.

Neutralisation is generally achieved using caustic soda and sometimes potassium hydroxide hydrolyzed lime and magnesium hydroxide also have wide utilisation. Although these neutralisation chemicals present certain handling and feeding problems associated with their solids content, metal solubility at the maintaining pH. In sometimes conversion of hydroxide precipitation to sulfide or carbonate precipitation to sulfide or carbonate precipitation in the neutralisation process will achieve necessary reduction in metal solubility. The recommended minimum retention time for the effective reduction is 30 mins, 15 mins in first stage reactor. The recovery of the metal from the precipitated sludge is a highly expensive process.

### Sources of waste in plating industry

There are three categories of waste which must be considered for the treatment.

### Drag out to rinses

This is carry over of concentrated process on the job which is removed by flowing water rinses.

### Bath dumps

Most of the process baths used in plating are expandable and to periodically discarded when their chemical activity is below a level acceptable for production process.

### Floor spill

This is a catch all category including both accidental and purposeful incidental waste sources such as tank overflow, drippage from work pieces, leaking tank, equipment and floor wash down water, oil drips from gear boxes etc.

Attention has been given on recovery technology of rinse water since they are the majority of the flow leaving an operation and necessitate waste treatment.

### Concentrate recovery process

There are a number of important factors which should be considered for the recovery of concentrate to the originating process. Majority of the plating solutions are expendable and have a finite life. Return of the drag out simply accepts this process and will give no net gain unless some regeneration scheme is adopted on the process itself.

Evaporation is one of the reliable rugged and straight forward method which can be used for waste treatment of zinc wash water. It is possible to treat zinc plating rinse water by this method. For the presently reported work, eco friendly, freely available solar energy is used for the treatment of rinse water.

### Solar still

Solar still is a manmade gadget in which natural hydrological cycles have been copied in a mini fashion. The simple solar still consists of a basin containing wash water over which a transparent cover normally plain glass or plastic sheet is fitted in an air tight position. This transparent cover is sloped to a desired angle to collect the distillate

in a trough. All the sides normally insulated to avoid radiation losses.

Solar energy passing through the transparent cover is absorbed by the wash water and thereby warms the water causing evaporation. As the transparent cover does not absorb much solar radiation it will be cooler than the water surface, producing convection currents in the air trapped inside the enclosure.

These currents bring the humid air into contact with the relatively cool cover and result in consideration of some of water vapour underneath the surface of the glass cover. This condensate rolls down the slope, flows along the trough and drains out of the enclosure through the outlet pipe. This process is either continuous or batch type one [5]. These type of solar stills are used for the production of distilled water or even drinking water in some areas.

### EXPERIMENTAL

For this study, single sloped basin type solar still has been employed. As the acid zinc may etch the conventional metal sheet like S.S. and G.I. PVC sheet has been used to fabricate a small sized solar still [6]

PVC sheet of 6 mm thick is used to fabricate the still. The size of the still is 305 x 305 mm (one square foot). One side of the still height is 200 mm and other is 125 mm. The top side is covered by 3 mm plain glass of size 300 x 300 mm. To fix the glass, ribs have been pasted to the inner side of the still. Tar plast is used to fix the glass on the top and still has been made air tight. For feeding the rinse water 15 mm dia PVC pipe has been fixed on one side. To collect the disscillate, one semi circular PVC trough has been pasted to lower side. For draining the rinse water, 15 mm dia PVC pipe has also been fitted (Fig. 1).

### RESULTS

The wash water from acid zinc bath was collected in a glass beaker and analysed. Analysis shows that 5 gm/lit of zinc was present in this solution. 1500 ml of zinc wash water was fed into the solar still in the place of saline water. This still is exposed to the sunlight. After 24 hours, the distillate collected at the outlet pipe was taken for analysis in Atomic Absorption Spectrophotometer

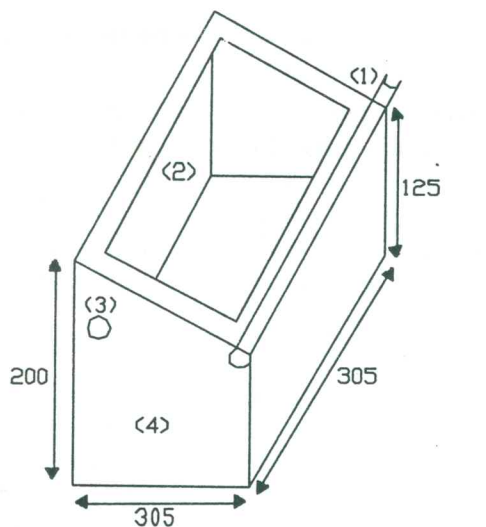

(1) D.I. water collection pipe  
 (2) Glass (3) Acid zinc wash water  
 (4) P V C sheet

Fig. 1: Solar still

(AAS) and found that the zinc content in this distillate is 0.5 ppm. The zinc content in the tap water used for general purpose 4 ppm which is less than the permissible limit of 15 ppm. The conductivities of this distillate and rinse water were also measured using Coronation Conductivity meter-Model 027 and the results are given in Table I. After few days, the significant concentrate solution in the still was analysed and the zinc concentration was found out to be 30 gm/lit. Due to the operation of solar still, both D.I water for drag out rinsing purposes and concentrated zinc plating solution from the wash water are produced. During this study, no operational problems were realised and no recurring expenses had occurred. At an average daily solar radiation of 950 w/m<sup>2</sup>, a typical solar still can produce about 3.5 lit. of distillate per sq. meter per day (Table II). The cost of this unit is about Rs.2500/- per sq. metre and larger area fabrication reduces the cost. The solar still can be integrated in the zinc plating process as shown in Fig. 2 which will be a zero discharge process.

TABLE I: Conductivity of various water

Water	Conductivity (milli mho)
Zinc wash water	2.380
Tap water	0.859
Distillate	0.016

TABLE II: Volume of distillate under different climatic conditions

Climatic condition	Solar radiation (W/ m <sup>2</sup> )	volume of distillate per sq.m per day (ml)
Normal day	950	3800
Cloudy day	800	3250
Rainy day	780	3100

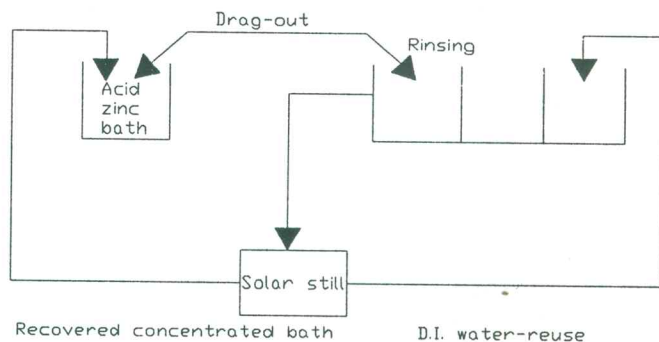

Fig. 2: Treatment of wash water of acid zinc plating bath

**CONCLUSION**

By using solar stills, D.I. water can be produced from the zinc wash water daily for make up water to the drag out tank and concentrated solution can be reused in the main plating tank. For a small scale unit, usage of solar still is economical, cost effective, eco-friendly technique and non-polluting device compared with chemical treatment. By adopting this technique environment can be saved from zinc pollution.

**REFERENCES**

1. S John, NV Shanmugam, E Vidyasagan, R Selvaraj and M Raghavan, *Trans SAEST* (1988)
2. S John, NV Shanmugam, E Vidyasagan and M Raghavan, *Trans SAEST*, 24-2 (1989) 195
3. *Metal Finishing Hand Book* (1996)
4. Clarence H Roy, *American electroplaters and surface finishers soc*, (1988)
5. MAS Malik, G N Tiwari, A Kumar and M S Sodha, *Solar Distillation*, Pregmann Press, Oxford (1982)
6. S John, PR Thangavelu, E Vidyasagan, P Veeramani and M Raghavan, *Trans of Metal Finish Assoc India* 3 (1994) 45