



Videotex Message Service Systems

Maurer, H.A., Rauch, W. and Sebestyen, I.

IIASA Working Paper

WP-81-113

August 1981



Maurer, H.A., Rauch, W. and Sebestyen, I. (1981) Videotex Message Service Systems. IIASA Working Paper. WP-81-113
Copyright © 1981 by the author(s). <http://pure.iiasa.ac.at/1648/>

Working Papers on work of the International Institute for Applied Systems Analysis receive only limited review. Views or opinions expressed herein do not necessarily represent those of the Institute, its National Member Organizations, or other organizations supporting the work. All rights reserved. Permission to make digital or hard copies of all or part of this work for personal or classroom use is granted without fee provided that copies are not made or distributed for profit or commercial advantage. All copies must bear this notice and the full citation on the first page. For other purposes, to republish, to post on servers or to redistribute to lists, permission must be sought by contacting repository@iiasa.ac.at

NOT FOR QUOTATION
WITHOUT PERMISSION
OF THE AUTHOR

VIDEOTELEX MESSAGE SERVICE SYSTEMS

H.A. Maurer
W. Rauch
I. Sebestyen

August 1981
WP-81-113

Working Papers are interim reports on work of the International Institute for Applied Systems Analysis and have received only limited review. Views or opinions expressed herein do not necessarily represent those of the Institute or of its National Member Organizations.

INTERNATIONAL INSTITUTE FOR APPLIED SYSTEMS ANALYSIS
2361 Laxenburg, Austria

ABSTRACT

Electronic message services supported by interactive videotex-like systems are described, classified, and analyzed in terms of the specific characteristics of such systems. A comparison of videotex message systems with other similar media is undertaken and the introduction of such service on an experimental basis is suggested. Recommendations are made to integrate special features, such as gateway services and an Integrated Electronic Directory System, into such systems.

CONTENTS

1. INTRODUCTION	1
2. MAIN CLASSES OF POTENTIAL VIDEOTEX SERVICES	2
3. VIDEOTEX MESSAGE SENDING SERVICES	4
3.1 Main Videotex Classes of Message Flow	4
3.2 Main Classes of Application of Videotex Message Sending	6
3.3 Hardware Characteristics of Videotex Message Service Centers	28
3.4 Network Concept for Videotex Message Service Centers	30
3.5 Videotex Informaton and Message Revenue Flows	30
3.6 Videotex Message Service User Guide	30
3.7 Economics of Videotex Messaging	30
4. CONCLUSION	36
REFERENCES	37

VIDEOTEX MESSAGE SERVICE SYSTEMS

H.A. Maurer, W. Rauch and I. Sebestyen

1. INTRODUCTION

Videotex systems, at least in their trial phase, have been with us for several years. The first broadcast videotex systems (such as "Ceefax" of BBC or "Oracle" of IBA) were introduced in the mid-1970s and were followed by the first interactive videotex systems (such as Prestel in the UK and Bildschirmtext in the FRG) towards the end of the decade. All the systems presently operating are still in their early infancy. At present, the main application of these systems is information retrieval with the aim of reaching the mass market including small-business companies, and in particular, the mass residential market. Whether from this point of view videotex will be a success or not is still an open question; it is believed that the next few years will give a definite answer to this question.

In its philosophy, videotex is what was AT&T's policy on cheap telephony at the beginning of this century, or Ford's policy in the automobile industry when he introduced the Model T. Ford's basic idea, to turn the automobile from a luxury and a plaything into a necessity, resulted in a story of success. He recognized the a vast potential market (business and residential) in the United States for low-priced cars. The results were spectacular: the Ford company made 15 million Model T's on its innovative moving assembly lines before production ceased in 1927.

Until 1900, the telephone also was a luxury in the US--the privilege of a "social and commercial aristocracy." About, 1900 however, the Bell Company started a campaign, unique in its energy, persistence, and success, to democratize this instrument and make it part of everybody's

daily. And despite the reduced price for phone service to small users, due to increased usage, increased revenues were collected.

By exploiting advanced, cheaper technologies, videotex-like systems too aim to reach the mass market through low costs. Automobiles and the telephone reached this market; why should videotex not succeed as well, if successfully applied, promoted, and introduced?

A key to the success of videotex-like systems will be the scope of their application. Information retrieval is one well-known application. Another major application, we believe, lies in its capability for supporting message sending. This paper aims to describe message sending via videotex-like systems, how it could be done, at what cost, and what possible impacts it would have on videotex itself, on other media, and on message sending services in general.

2. MAIN CLASSES OF POTENTIAL VIDEOTEX SERVICES

Many papers describe the main areas of videotex applications. In general, six main generic classes of services, as videotex applications, can be identified (Tydeman and Zwimpfer 1981, Maurer 1981):

- 1) Information retrieval
- 2) Games/entertainment
- 3) Transactions/teleshopping
- 4) Electronic messaging
- 5) Data processing
- 6) Telemonitoring/home management

Table 1 provides a rough (but not comprehensive) overview of present videotex services and trials and their existing and proposed applications.

It can be seen that presently the "information retrieval" aspect of videotex is being most exploited (in 89% of all presented systems), the second-largest field of application (49%), "transactions," is usually integrated with "information retrieval" in the form of on-line ordering. On-line ordering is supported by all "Prestel-like" systems by means of so-called response frames, which provide user feedback to information providers. The response frame option of Prestel-like systems can already be classified as a special sort of electronic message sending, another major category of possible videotex applications. However, in its more complex forms at least, "electronic message sending" requires an alphanumeric keypad or keyboard, while the "response frames" of Prestel-like systems can usually be easily filled out using only a numerical keypad. It is characteristic of the present situation that the electronic message sending capabilities of videotex-like systems are only being utilized in a limited way. (Only 19% of the studied systems shown in Table 1 had message-sending capabilities.) It is the authors' strong belief that videotex-like systems can achieve a breakthrough to the mass market and become a part of everyday life only if all major applications, including message sending in particular, are simultaneously fully utilized

Table 1. Existing and proposed videotex applications (1981) (adopted from Tydeman and Zwimpfer 1981).

	Info. Rtrvl.	Games/ Enter.	Trans- actions	Elect. Msg.	Data Proc.	Home Mgmt.	Country
Viewtron	X	X	X	-	-	-	USA
OCLC	X	X	-	-	-	-	USA
QUBE	-	X	X	X	X	X	USA
The Source	X	X	-	X	X	X	USA
CompuServe	X	X	-	X	X	X	USA
AT&T/EIS	X	-	X	-	X	-	USA
Belo/Sammons	X	-	-	-	-	-	USA
KSL-TV	X	X	-	-	-	-	USA
CBS	X	X	-	-	-	-	USA
Closed Captioning	X	-	-	-	-	-	USA
Green Thumb	X	-	-	-	-	-	USA
Prof.Farmers	X	-	-	-	-	-	USA
Comp-U-Star	-	-	X	-	-	-	USA
Dow Jones	X	-	-	-	-	X	USA
Datacast	X	-	-	-	-	-	USA
Cabletext	X	-	-	-	-	-	USA
WETA-TV	X	-	-	-	-	-	USA
Times-Mirror	-	X	X	-	-	-	USA
Assoc.Press	X	-	-	-	-	-	USA
HomServ	-	-	X	-	-	-	USA
Prestel Int'l	X	-	-	X	-	-	UK
Prestel	X	X	X	-	-	-	UK
Teletel	X	-	X	X	-	-	France
Telset	X	-	X	-	-	-	Finland
Bildschirmtext	X	-	X	-	-	-	FRG
Bildschirmtext	X	X	X	-	-	-	Austria
Telephone- Bildschirmtext	X	-	X	-	-	-	Switzerland
Viditel	X	-	X	-	-	-	Netherlands
Telidon	X	X	X	X	-	-	Canada
Vista	X	X	X	-	X	-	Canada
Electronic Directory	X	-	-	-	-	-	France
Captain	X	X	X	-	-	-	Japan
CEEFAX	X	X	-	-	-	-	UK
ORACLE	X	X	-	-	-	-	UK
Videotext	X	X	-	-	-	-	FRG
Teletext	X	X	-	-	-	-	Austria
Total [100%]	89%	49%	43%	19%	14%	11%	

and supported in an integrated way.

Because until now the electronic message sending option of videotex-like systems has received relatively little attention, the purpose of this paper is to analyze the opportunities offered by videotex-like systems in the field of electronic message sending.

3. VIDEOTEX MESSAGE SENDING SERVICES

3.1 Main Videotex Classes of Message Flow

According to P. Woolfe (1980), with a videotex message service (or electronic mail service) users (message senders) can bring specific pages of text to the attention of other users (recipients). Message senders can:

- a. select a message page by choosing from a menu of pre-formatted pages such as "Happy birthday" (this can be done easily even using numeric keypads); or
- b. enter and edit pages of message information (best accomplished using extended alphanumeric keyboards).

The most typical flow of videotex messages is described in 3.1.1, less well-known possibilities are described in 3.1.2 and 3.1.3.

3.1.1. Store and Forward

In the "store and forward" type message flow, messages between users are sent through the videotex service centers to "message databases" and upon the request of the sender, are delivered to a dedicated mailbox, "owned" by the recipient and preferably identified by a number similar or identical to the telephone number. The message can then be retrieved by the "owner" (recipient) of the mailbox at any time after its delivery.

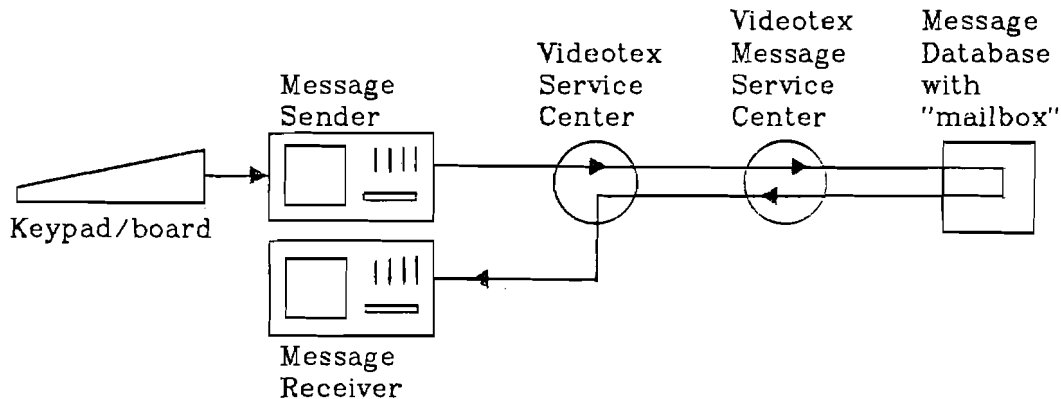

Figure 1. The principle of "Store and Forward" message flow.

3.1.2. Conversational Messages via Videotex Service Centers

Conversational messages are instantaneous. This technique does not require message storage in mailboxes, and allows exchange of messages in a manner conceptually similar to the normal telephone or telex service. This service can supplement the ordinary telephone service and in combination with the telephone service is ideal for sending addresses, names, simple graphics, etc. This form of videotex usage also enables the deaf to communicate via telephone.

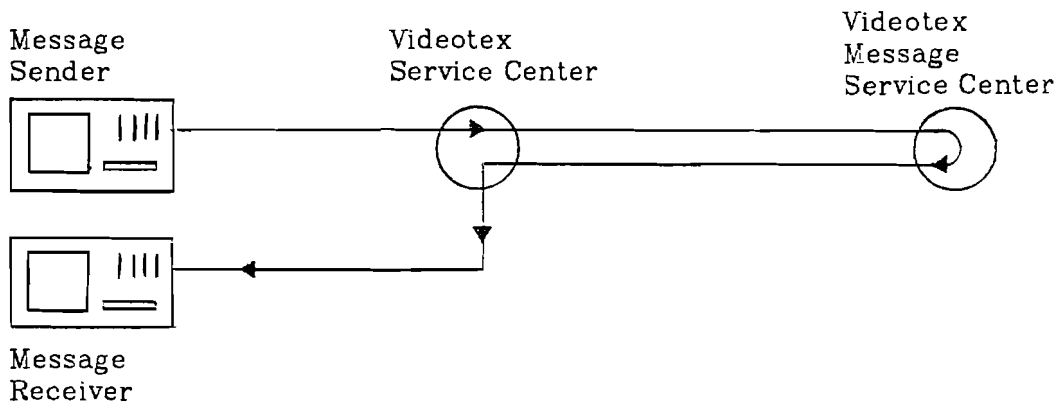

Figure 2. The principle of conversational message flow via videotex service centers

3.1.3. Direct Terminal-to-Terminal Conversational Message Flow

This category is very similar in its function to the previous one. However, the communication does not go through videotex service centers.

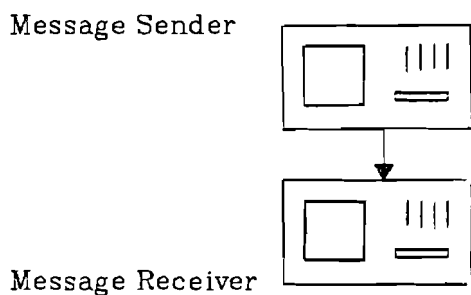

Figure 3. The principle of conversational, direct terminal-to-terminal videotex messaging.

3.2 Main Classes of Application of Videotex Message Sending

In the following section, the above three main classes of application for videotex message sending are discussed at some length observed from a different--less technical but more application-oriented--angle.

3.2.1 Simultaneous (Conversational) Exchange of Messages

In simultaneous message exchanges (see 3.1.2 and 3.1.3), as with verbal telephone conversations, both partners to the conversation have to be "logged on" at the same time to the videotex message sending system so that initiating messages and responding messages can alternate without forced delay. The exchange of messages may or may not go through videotex service centers. The advantage of using videotex service centers is that they can provide additional "value added service functions" such as enhanced editing, pre-formatted message pages, the Integrated Electronic Directory System or the division of the display screen into two halves showing outgoing and incoming messages simultaneously. Such services--except for the Integrated Electronic Directory System--can of course be built into the terminal equipment as well--at the added cost of additional local intelligence in hardware and software, and at higher terminal equipment prices.

3.2.2 Non-simultaneous Videotex Message Sending Services

3.2.2.1 Message Exchange Between Videotex Users

a) Individual messages

The sending of individual messages between two videotex users is somewhat similar to a telephone conversation between two subscribers. One significant difference is the temporal coincidence necessary for telephone conversation. The introduction of computer message systems gives individuals the freedom to choose the time of interaction. Also, the actual physical location of the recipient is not an essential factor as in case of the telephone: the messages can be picked up practically independently by of location.

In order to define some specific parameters of message sending systems (such as how many frames should be allocated to each mailbox), let us examine some characteristics of telephone conversations (Ithiel de Sola Pool 1977), so that we can draw some conclusions about the possible nature of videotex messaging. (These characteristics of telephone usage were identified for the US. However, the pattern is very similar for other developed countries.)

- Several studies show that about half of all telephone calls originating from households are made to numbers that are within a two-mile radius; i.e., people make most of their telephone calls to persons in their own neighborhood (Figure 4). Perhaps this behavior would change somewhat if costs became distance-independent.

Percent of Calls

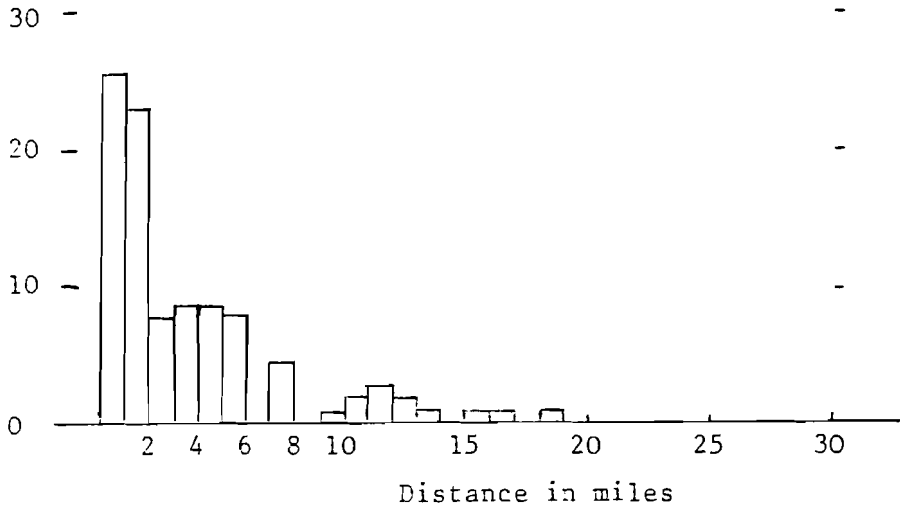

Figure 4. Distance of local calls (Ithiel de Sola Pool 1977).

- The average telephone usage per household is relatively low: US statistics show that the number of local calls per household lies at two calls per day (Figure 5). This figure is even lower for countries such as UK, FRG, France, etc. (Figure 6).
- About 20% of all residential calls go to the same receiving number and the next four most frequently called numbers account for another 30-40% (in total 50-60%!) of all calls. The part of these calls whose purpose is to obtain information could be covered ideally by the information retrieval function of videotex. Sending short messages, announcements, orders, complaints, etc. to central places would be an ideal application for individual message sending by videotex. The median household dials only 25 different numbers. An interesting social aspect--usually one does not make new friends on telephone. This could be changed by means of videotex teleconferencing or teleplaying (Maurer et al. 1981).
- The average length of a call from a residential telephone is just over 4-1/4 minutes (Figure 7). Thirty percent of all calls last less than 30 seconds, and almost 50% last less than a minute. This portion of all telephone calls is the main candidate for replacement by the message service of videotex.

Percent of Accounts

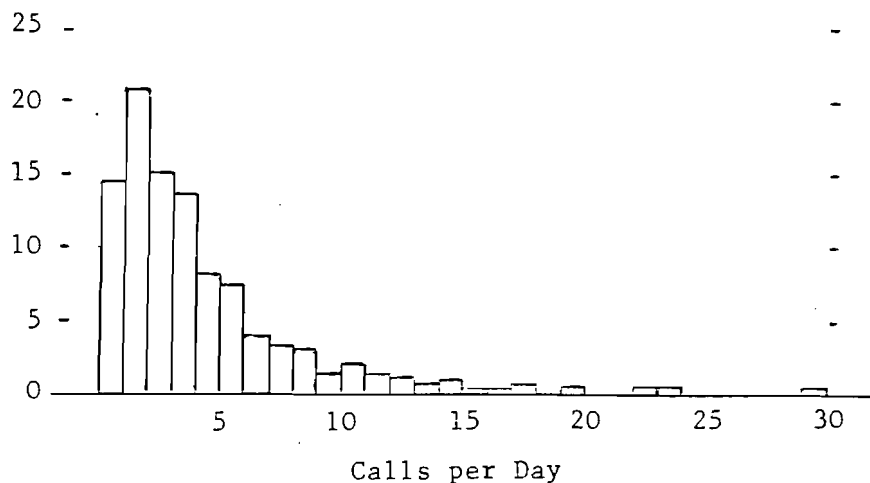
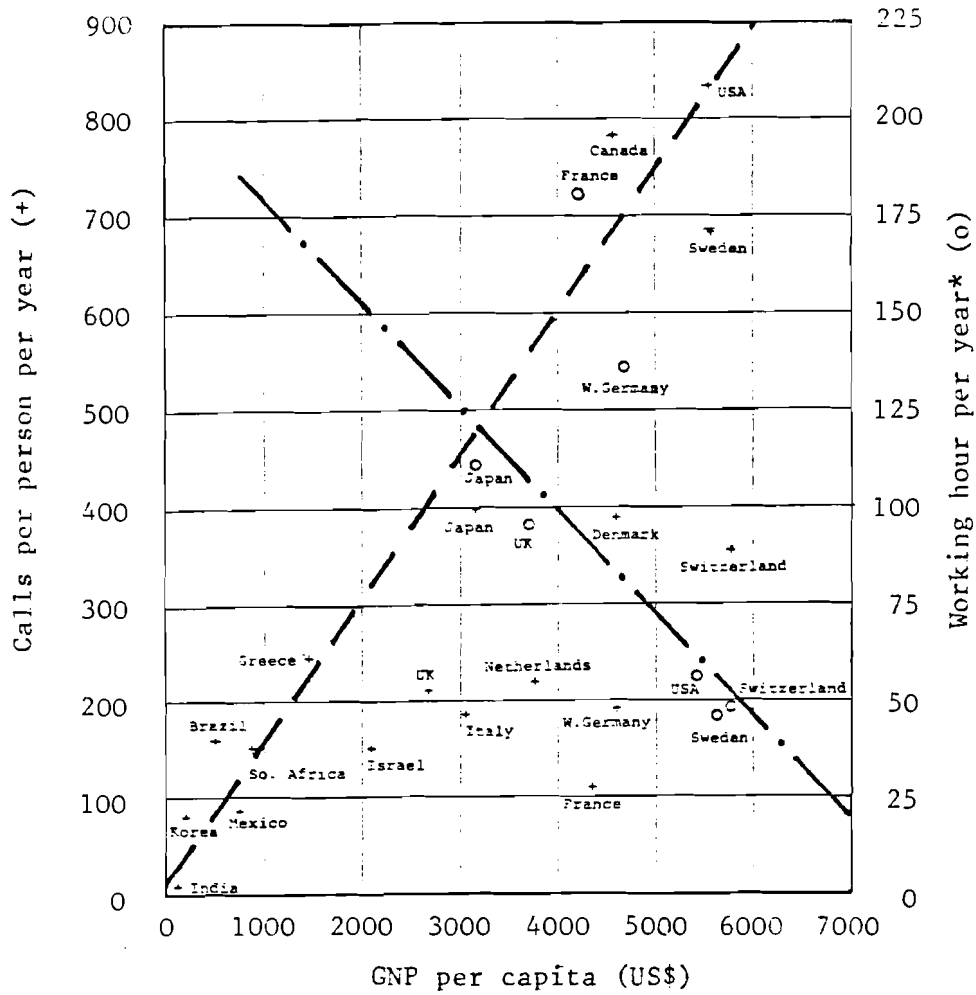

Figure 5. Local calls originating per customer per day in the US (Ithiel de Sola Pool 1977).

- Approximately every second telephone call fails to reach the person called. This problem could be alleviated by videotex-supported message systems using the mailbox principle, where proper timing is not a constraint.
- The "average holding times by time of day" show very different pictures for residential and business users (Figure 8). There is a sharp change in the telephone usage pattern after 5 p.m. (end of business, people return home).

Between 7 a.m. and 5 p.m. (during working hours) the average holding time is about 3.5 minutes. This is the time when people are active and their time is usually limited. A part of these telephone conversations (e.g., "Please call back," or "Meeting will take place at 3 p.m.") could be replaced ideally by videotex mediated messaging (Figure 9). After 5 p.m. business calls become shorter. This is the period of short messages, since business partners do not want to disturb each other's free time and tend to exchange only the most essential messages. These too could be replaced ideally by videotex messaging. In the area of residential people are back at home after 5 p.m. and have more time to chat with each other. Hence, this is the time of day for longer residential telephone calls and for watching TV as well, and thus is less ideal for videotex messaging.



- * calculated on the basis of a yearly telephone usage pattern of
 - 500 local calls
 - 250 long distance calls (100 km)
 - installation fee (distributed for 10 years)

Figure 6. Comparison of per capita calls and working hour in relation to GNP. (Data from the World's Telephones; The World Almanac, 1975 and Telekommunikationsbericht 1976).

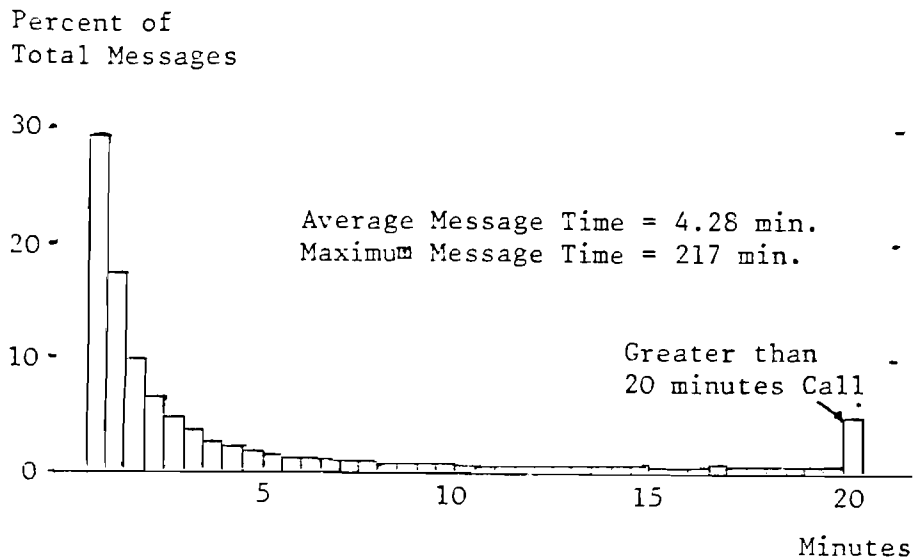
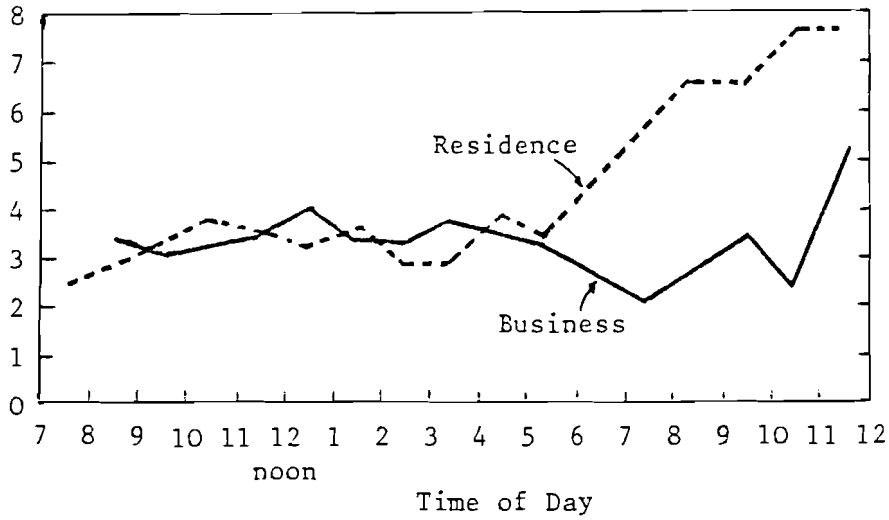

Figure 7. Local area message holding time (Ithiel de Sola Pool 1977).

- The *Social role of the telephone* is reflected in the types of calls missed by respondents when the telephone is not available (Wurtzel and Turner 1977). On February 27, 1975, a fire in a major switching center of the New York Telephone Company left a 300-block area of Manhattan (144,755 phones and 90,300 Bell customers) without telephone service for twenty-three days. To focus upon the telephone's social role, people were asked whether they missed the phone and, if so, what kinds of calls they had missed most (Table 2) and what other means of communication they used during the black-out.

In total, 63.7% of the respondents missed the ability to make calls to friends and family. In the area which is perhaps closest to the retrieval function of videotex, i.e., business, medical, shopping, the total of missed ability was approximately 30%. If, at the time of the accident there was a way of satisfying this 30% by means of interactive videotex, which of course technically would have been impossible, probably only 10% would actually be candidates for replacement by the retrieval function of videotex, a surprisingly low percentage. The figures in Table 2 imply that even if the information retrieval function of videotex gains increased attention in the mass market and acquires higher social values, videotex information retrieval will probably not come close to the volume of telephone for maintaining close contacts between people. Other forms of videotex applications such as message sending would get greater attention.



Averages

	<u>Residence</u>	<u>Business</u>
Day	3.40	3.49
Evening	5.30	2.97
Total*	4.15	3.48

* includes "Night" Period

Figure 8. Average holding time by time of day (weekdays) (Ithiel de Sola Pool 1977).

	7a.m.	5p.m.	12p.m.
Residential usage	Messaging (*) or short conversation	Longer conversation	
Business usage	Messaging (*) or short conversation	Messaging (*)	Computer communication (electronic mail, file transfer)

7a.m. 5p.m. 11p.m.
Time of day

Figure 9. Telephone usage pattern and potential replacement for telephone by videotex messaging(*)

Table 2. Types of calls missed by respondents (Ithiel de Sola Pool 1977).

Type of Call	Missed Ability to Make Call to		Missed Ability to Receive Call from	
	N	%	N	%
Friends	89	36.3	108	44.8
Family	76	31.0	89	36.9
Business	39	15.9	27	11.2
Medical	24	9.7	9	3.7
Shopping	10	4.1	2	0.8
Other	7	2.9	6	2.5
Total	245	99.9	241	99.9

(Totals do not sum to 190 since respondents could reply to more than one type of call.)

Another interesting aspect of the above survey is that during the telephone black-out, only relatively few people increased their use of other modes of communication:

- 10% wrote more letters.
- 2% communicated via telegrams

This seems to imply that these other media for communication do not make serious competition to the telephone at the present stage.

On the other hand:

- 48% used the emergency telephone installed on the street.
- 33% made their calls from work.

Showing that the usual communication habits cannot be changed easily.

Summary: Approximately 50% of all oral telephone calls could be candidates for replacement by videotex-supported messaging. From the carriers' (PTTs') point of view there would be definitely no loss in traffic and revenue (on the contrary) and the new "value added services," such as videotex messaging would be attractive in everyday life.

b) Group messaging supported by videotex systems

Group messaging supported by videotex-like systems also will be a "value added function," over the classical function of telephone calls. As mentioned above, 50% of all residential telephone calls are made to the five most frequently called numbers. These "few" from "many"--if replaced by videotex traffic--will be partly covered by the response frames of videotex-like systems, as the five most frequently called numbers (be it local council or local supermarket) are probably those of the local information providers. Another alternative for this function is group messaging supported by videotex message systems (for example, reminders to pay their taxes to be sent out by the local council to those who have not transferred their financial "contribution" yet). In a similar way, individual residents might use this facility, for example, for reminding their friends to come to their party on time. This function, however, is a special type of videotex messaging, where one sender addresses many recipients, and thus technically it is handled with the simple form of videotex message sending. Care will have to be taken in this connection to avoid the emergence of "electronic junk-mail" (Maurer 1981).

c) Videotex teleconferencing

Teleconferencing supported by videotex-like systems is an exciting new field that is not supported by traditional telephone services. Based on videotex, computerized teleconferencing might go public. Computerized teleconferencing over videotex might open new opportunities: It would hopefully bring together people not knowing each other; it could help to reduce time and cost for unnecessary travel; and it could help to discuss and perhaps solve local problems (such as "Should a new post office be built or not, and if so where?")

By definition (Hiltz and Turoff 1978) a computer conferencing system uses the computer to structure, store, and process written communications among a group of people. When a so-called conference comment is entered through one terminal (here, the modified TV screen outfitted with an alphanumeric keyboard) it may be obtained on the recipients' terminals immediately or at any future time so long it is not purged from the computer's memory. In addition, the system supports the search and review of earlier materials, using such criteria as author and/or date and subject. Specific conferences can accommodate from two to 100 or more participants, depending on the purpose of the conference. As mentioned, it can be used in connection with local problems such as building a new road or organizing a local cooking class. The "duration" of such conferences is usually by nature long: it lasts months, sometimes even years. These systems might also support the function of "notebooks," where "conference members" can send or draft joint manuscripts--they may play the role of a "bulletin," which might replace a "newsletter" for a given closed group.

Special human roles in teleconferencing systems are:

- a. the "bulletin editor," who solicit entries, appoints reviewers, and writes and edits comments;
- b. the "conference moderator" who invites participants, sets agenda, deletes/edits conference comments, summarizes, and calls for votes or new discussion items;
- c. the "group coordinator" (administrative assistant) who provides assistance to members, sends group messages of general interest, and acts as an interface to other groups.

Whether the concept of computerized teleconferencing can be made a successful aspect of videotex messaging is still an open question, but it is worthwhile to try.

3.2.2.2 Gateway Services Between Users of Videotex Like Systems and Other Means of Communication

The concept of gateways between communication media providing similar service functions is essential. To build communication infrastructures, such as mail, telegraph, telephone, telex, data-communication, teletex, and videotex networks, requires decades, not just a few years. Therefore, telecommunication infrastructures of "competing" media have to live with each other for decades. This makes it possible to ensure the smooth transmission of certain service functions from one medium to the other. Figure 10 shows some historical figures (US Department of Commerce 1975, 1979) on competing telecommunication media in the US. The number of telephone calls and pieces of first class mails per person per year have increased over a long period. The speed of growth is highest for telephone calls; the growth of mail traffic is somewhat lower and seems to be leveling off. The number of telegraph messages per person per year continues to drop, after having reached its maximum around 1930. Today, the function of telegraph is diminishing, its role having been slowly taken over by telephone and to a certain extent, by telex. The overlapping periods of telegraph and telephone, and telegraph and telex have been 100 and 45 years, respectively. And yet the telegraph still plays a modest but important role.

In Figure 11 we see a forecast of the impact of teletex--the fast computer-supported "super telex"--on ordinary telex systems (Rueggeber 1980). The "takeover" of teletex from telex in the FRG will last over two decades. The total traffic through both media, however, will continue to increase, and a gateway service between telex and teletex is planned from the outset.

In connection with the gateway notion, both of the above figures prove and suggest that

- a. "competing" telecommunication media have to live with each other for rather long periods, as the process of market penetration and user acceptance of any new medium needs a long "overlap," lasting decades;

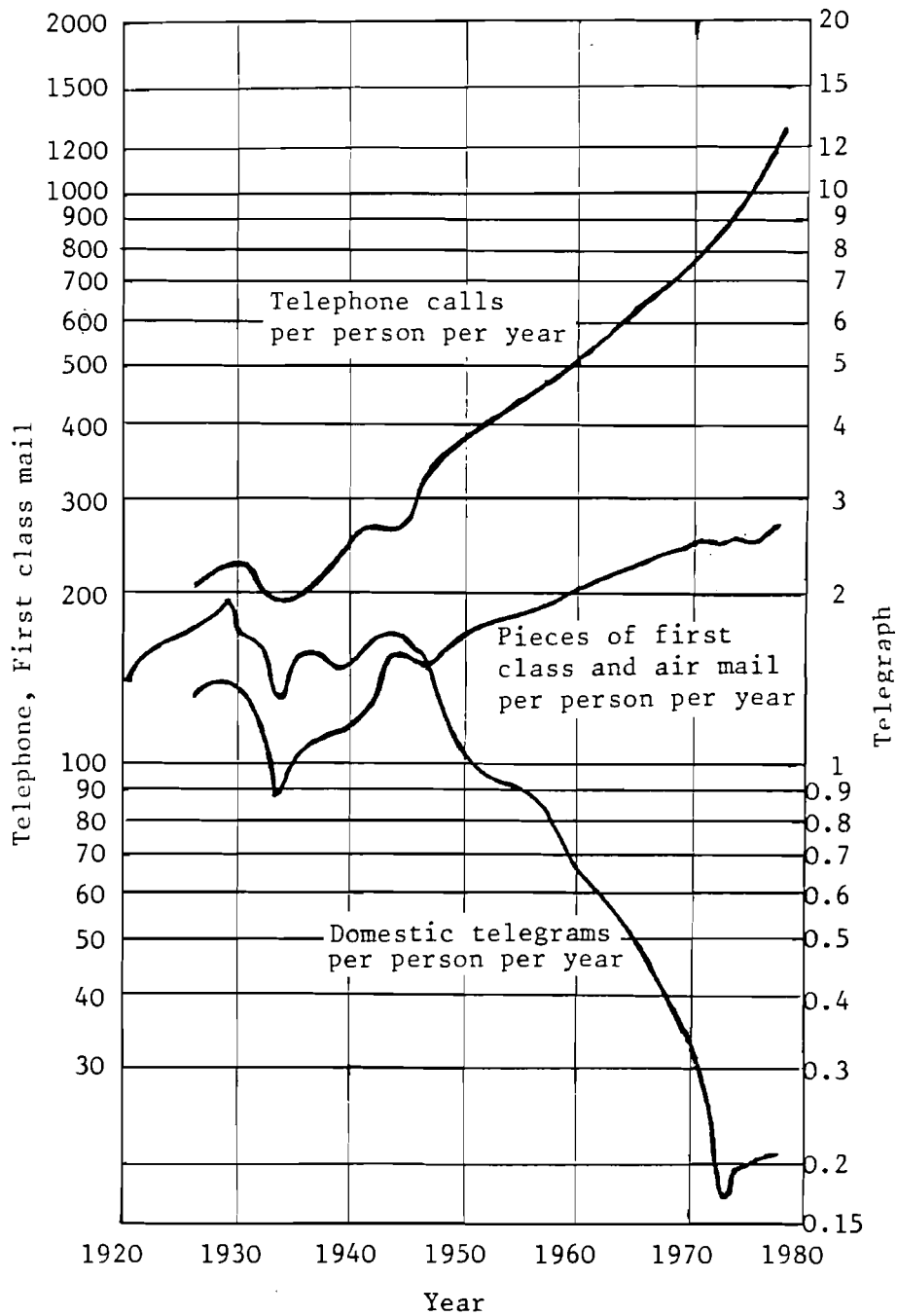

Figure 10. Number of telephone calls, pieces of first class mail and air-mail, and telegrams per person per year in the US (US Department of Commerce 1975, 1979).

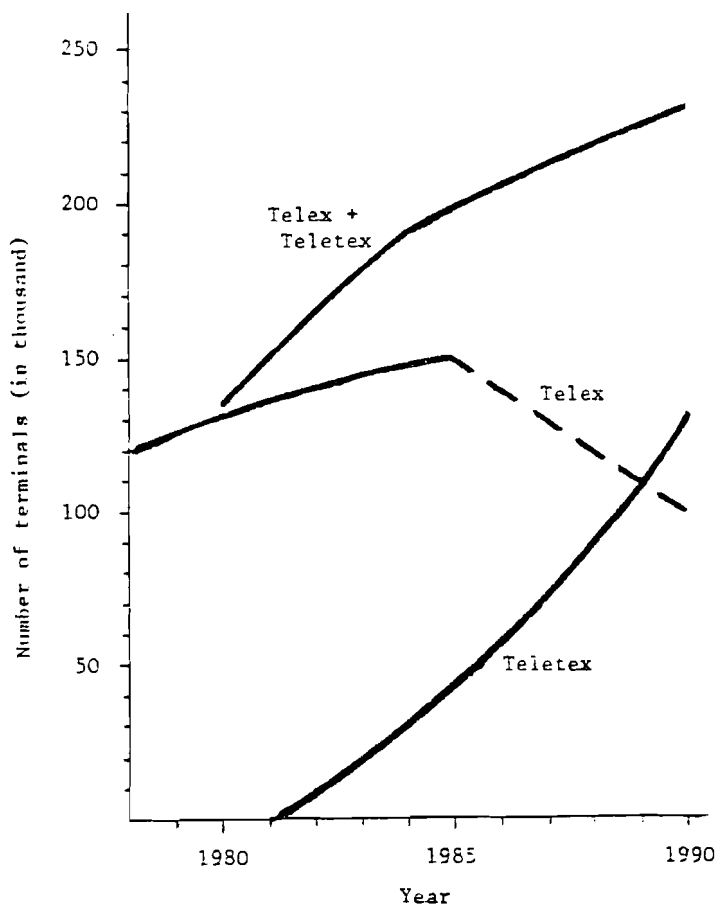

Figure 11. Estimated impact of teletex on telex in the FRG (Rueggeber 1980).

- b. the lack of a "gateway" between "competing" telecommunication media during such an "overlap" period badly affects the usefulness of both the old and new media and the market penetration of the new medium, since the strength of all telecommunication media lies in the ability of users to communicate with as many other users (be they on the same system or not) as possible;
- c. the gradual take-over gives sufficient time to Post and Telecommunication Administrations to take into account the possible impacts of the new medium on usage, labor, and investment and to initiate appropriate actions.

a) Gateway to traditional mail service

In order to assess the possible impacts of videotex-like systems with message sending capacity, a significant communication flow (preferably mail) between sectors such as "business," "household," and "government" has to be looked at.

Several independent studies from different developed countries show very similar flow patterns among the above sectors (Bessant et al. 1981, Telekommunikationsbericht 1976) (Table 3). Thus, in the following, the data of the KtK Report (Telekommunikationsbericht 1976) will be taken as a typical example of mail flow pattern (Table 4, Figure 12).

The figure 9.61 billion a year means that per working day 36 million "mail units" have to be delivered from their sources to the recipients. According to the KtK study, in principle, around 20 million "mail units" per day are electronically transferable, whereas the rest is unsuitable for electronic transmission because of inconvenient physical size, volume, format, and/or content.

Possible means of electronic transmission are as shown in Table 5.

Table 3. Sources and recipients of mail communications (%). (Figures for USA and for UK--1968 (Bessant et al. 1981), FRG--1973 (Telekommunikationsbericht 1976)).

Source	Business			Household			Government			Recipient total		
	USA	UK	FRG	USA	UK	FRG	USA	UK	FRG	USA	UK	FRG
Business	25.8	30	29	5.8	15	5.5	1.8	na	2.5	33.4	na	37
Household	46.6	40	34.5	14.0	na	12	3.8	na	7.5	64.4	na	54
Government	1.2	na	3.5	0.4	na	2.5	0.6	na	3.0	2.2	na	9.0
Source total	73.6	na	67	20.2	na	20	6.2	na	13	100	na	100

Table 4. Share of mail communication by type and format of units in 1973 in the FRG (Telekommunikationsbericht 1976).

Type	Units (billion)
Letters	5.63
Letter type printed matters	0.35
Printed matters	0.78
Mass printed matters (e.g., advertisement)	1.45
Miscellaneous (books, samples, parcels, printed matters from abroad)	0.54
Total	9.61

Figure 13 shows (according to the KtK study format and content) all possible transferable mail traffic.

The KtK study is rather conservative in its estimate of the potential of possibly transferable mail traffic. It does not take into consideration the possibility of "inter-office computer communication" in the business sector and the possibility of introducing cheap telefax equipment and videotex-like systems in the private sector. Nor does it take into consideration the basic concept of "telecommunication gateways" between media mentioned earlier. By means of the above mentioned media and concept it seems to be potentially feasible in the most developed countries to transfer, 50-60% of the total mail traffic in a time horizon of a few decades. However, more detailed qualitative and quantitative studies on this will have to be undertaken in the future. Figure 14 shows the possible connections among telecommunication media presently seen. Some gateways shown have already been implemented or are under development; others are not even in the planning stage yet. All gateway possibilities shown can be realized without major difficulty with the technology known. However, which of them will actually be implemented will depend on actual needs, costs, and policy decisions. From the policy-making point of view, countries with a single PTT (that is in a monopoly position and is more "interdisciplinary" in nature) seem to have an advantage over countries where the different telecommunication media are run by different companies having licence for a particular type of telecommunication service, as in the USA.

Looking at the columns and rows for videotex-like systems in Figure 14, the *gateway: "videotex/traditional mail"* seems to be of particular importance, especially in the private sector. Through this gateway, letters could be edited at home and sent over the videotex network to the videotex message service center nearest to the location of the recipient, where the message would be automatically enveloped* and distributed

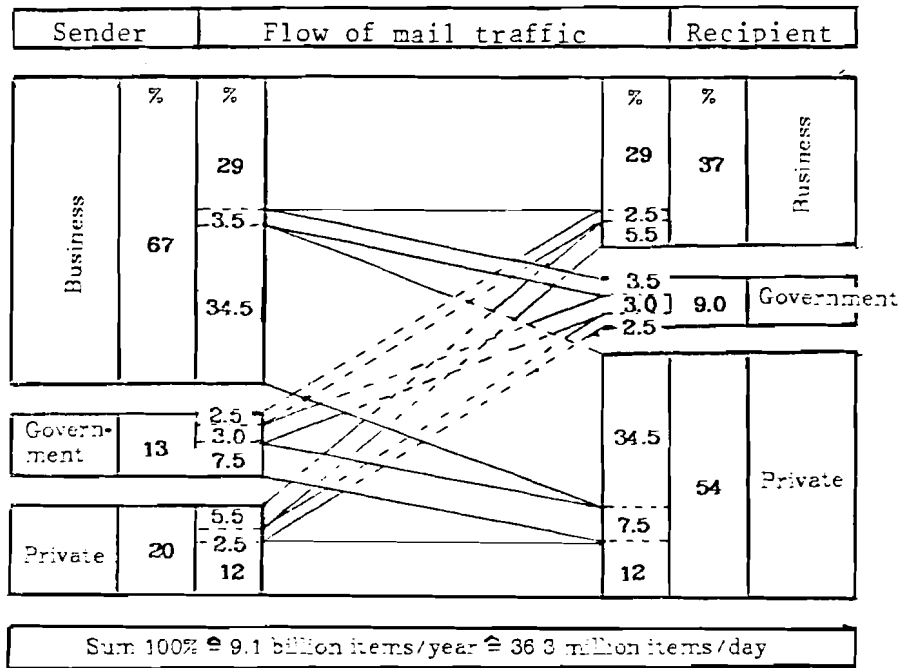

Figure 12. Structure of mail traffic (letters, post cards, all sort of printed matters) in the FRG (1973) (Telekommunikationsbericht 1976).

locally in the traditional way.

Letters of this kind could be sent over through the videotex network either by "special delivery," arriving within a few hours, or (preferably) during the night when usage is low and be delivered with the early morning mail. In this way, mail delivery within 24 hours could be guaranteed. This guarantee can no longer be made by many PTTs for traditional mail service.

Advantages of the "videotex/traditional mail" gateway: The "videotex/traditional mail" gateway provides two essential advantages for the Videotex Message Service System:

* Closed envelopes could be used where one side is carbon paper, and the other, plain paper and which are typed on at the outside (only showing the desired message when opened which is unreadable, otherwise) could be used.

Table 5. Possible media for substituting conventional mail service.

Communication medium	Suitable for:	
	Business & Government	Household
Telex	X	
Teletex	X	
Telefax (Analogue)	X	X ¹
Videotex like systems	X	X
Inter-office computer communication ² ("Private networks")	X	

Note:

1. Low cost telefax equipment presently under development (e.g., in France (Foel Stratte-Mc Clure 1980), Thomson-CSF; Matra, SAGEM is planning to bring out cheap telefax terminals for about US\$500; with an amortization cost of US\$4.1/month given an estimated lifetime of 10 years).
2. Inter-office computer communication means professional private network systems similar to SWIFT, SITA, Philips/Unilever inter-office networks, etc.

- *The gateway considerably improves the value of the message service system, by increasing the number of participants who may receive messages (see Figure 15).*
- The overlapping geographical coverage of "videotex message service" and "traditional mail service" would allow videotex mediated messages to be re-routed via traditional mail if needed. This fact is most essential from the following point of view:

There is a basic difference between the behavioral pattern of the ordinary mail service and its users, and the videotex message service system and its users (Table 6).

Recipients of videotex messages must take an active part in the message sending procedure by picking up messages from their own mailboxes. If a recipient of a message does not check his mailbox, no message sent to him will in fact reach him, and hence the original aim of the sender--that his message be read--is not fulfilled. However, through a feedback mechanism--an essential advantage of an electronic system--the sender is informed of this fact. The gateway mechanism would enable the sender as well as the recipient to convert the communication

Sender		Flow of mail traffic			Recipient	
Business (Government included)	%	%		%	%	Business (Government included)
	79	40		40	48	
Private						Private
	21	39		39	52	
		8		8		
		13		13		
Sum. 100% = 5 billion items/year = 20 million items/day						

Figure 13. Format and content of all possible transferable mail traffic in the FRG (Telekommunikationsbericht 1976).

medium output from videotex to mail, where the passive behavior of the recipient does not affect the physical delivery of the message to its destination. (Whether or not the message will be read is another question.) In some cases the recipient may want messages coming to his electronic mailbox to be re-routed and delivered by traditional mail, such as in the case of longer absence from the system (e.g., holiday). An interesting and useful combination seems to be the introduction and utilization of a time factor: if the recipient does not pick up his message from his mailbox within a time period predefined by the sender or recipient, then the message should be delivered by mail (which would then arrive within 24 hours).

Through the above mechanism a major barrier, existing in almost all computerized message sending system, could be overcome.

The costs for the "gateway" service (automatic printing, enveloping) and the delivery of the mail would have to be borne by the partner instructing the system to reroute the message by mail.

Recipient	Sender									
	Business & government					Household				
	Telex	Teletex	Telefax	Inter-office computer communication	Videotex	Mail	Cheap Telefax	Videotex	Mail	
Business-Government	X	Ⓞ ²	-	-	-	-	-	-	-	-
	Ⓞ ²	X	-	G	Ⓞ	-	-	Ⓞ	-	-
	-	-	X	-	-	Ⓞ ²	X	-	Ⓞ ²	Ⓞ ²
Inter-office computer communication	G	G	-	X	G	-	-	G	-	-
Videotex	-	G	-1	G	X	-	-1	X	-	-
Mail	-	Ⓞ	Ⓞ ²	G	Ⓞ	X	Ⓞ ²	Ⓞ	-	X
Household	-	-	X	-	-	Ⓞ ²	X	-	Ⓞ ²	-
Cheap Telefax	-	G	-1	G	X	-	-1	X	-	-
Videotex	-	G	Ⓞ ²	G	Ⓞ	X	Ⓞ ²	Ⓞ	-	-
Mail	-	G	Ⓞ ²	G	Ⓞ	X	Ⓞ ²	Ⓞ	-	X

Note:

-: no link required; X: "obvious" connection; G: gateway possible; Ⓞ: gateway necessary

1. Interface to videotex is in principle possible (see Japanese plans) however here we have taken into consideration CCITT standard telefax equipment.
2. Already developed or under developed.

Figure 14. Possible gateways between telecommunication media presently perceived and potentially able to partly take over traditional mail traffic

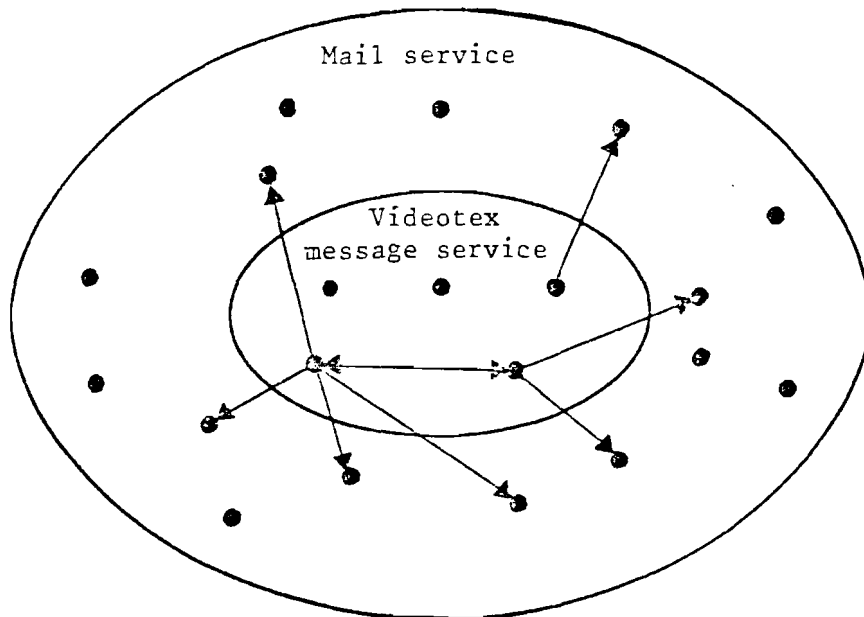

Figure 15. Expansion of videotex message sending coverage through videotex/traditional mail gateway.

Table 6. Behavior pattern of mail and videotex

Medium \ Behavior	Sender	Recipient	System response
Traditional mail service	active role	passive role	no acknowledgment of delivery (no feedback)
Videotex message service	active role	active role	acknowledgment of delivery (feedback)

On the following flow chart (Figure 16) a simplified sending procedure is shown.

b) Telex/teletex gateway service

A gateway between telex and videotex is also feasible and would enlarge the message sending community. The connection between "household videotex" and "business teletex" seems especially interesting and would probably be easiest to implement.

Gateways linking videotex and with telegraph, telex, respectively, are also feasible, but less likely, as both the telegraph and telex systems are losing significance as telecommunications media and are likely to disappear within the next decades. Furthermore, gateways between teletex and telex are planned anyway, and can be used between videotex and telex if the gateway videotex/telex exists.

3.2.3 Special Services—The Integrated Electronic Directory System

The first Electronic Directory System is presently under development for 250,000 telephone subscribers in the Ille and Vilaine region of western France; with this system paper telephone directories will be replaced by alphanumerical terminals during the next decade.

The French system will include both the so-called "white" and "yellow" pages, including business advertisement material. By ensuring common videotex standards and protocols, the very same directory terminals will technically be able to take part in the interactive videotex (TELETEL) service as well (Foel Stratte-Mc Clure 1980). It is hoped that by replacing the paper telephone directories with terminals, not only will more up-to-date information be provided, but it would also lead to significant savings in material (paper), transportation, and labor costs.

The concept of the French Electronic Directory System is the first step toward a so-called "Integrated Electronic Directory System," and is an important advancement. However, further steps must follow.

The concept of an "Integrated Electronic Directory" seems to be essential to every type of message sending. It should include several types of information and hence should be significantly broader and more integrated than the French Electronic Directory System (see Table 7).

The Integrated Electronic Directory would be a comprehensive computerbased database containing information necessary for each type of communication on every participant. It would probably be the first directory which would combine telephone, telex, teletex, and telefax subscribers and mailing address of subjects. The "yellow page" information on individuals would have to be handled with particular care, because of the privacy aspect. However, it would also be the first attempt to group, select, and bring together people with similar interests. The type of information provided by participants in the system--be they business firms or individuals--should be governed by the participants. Each piece of information will be submitted by the participant and will be checked

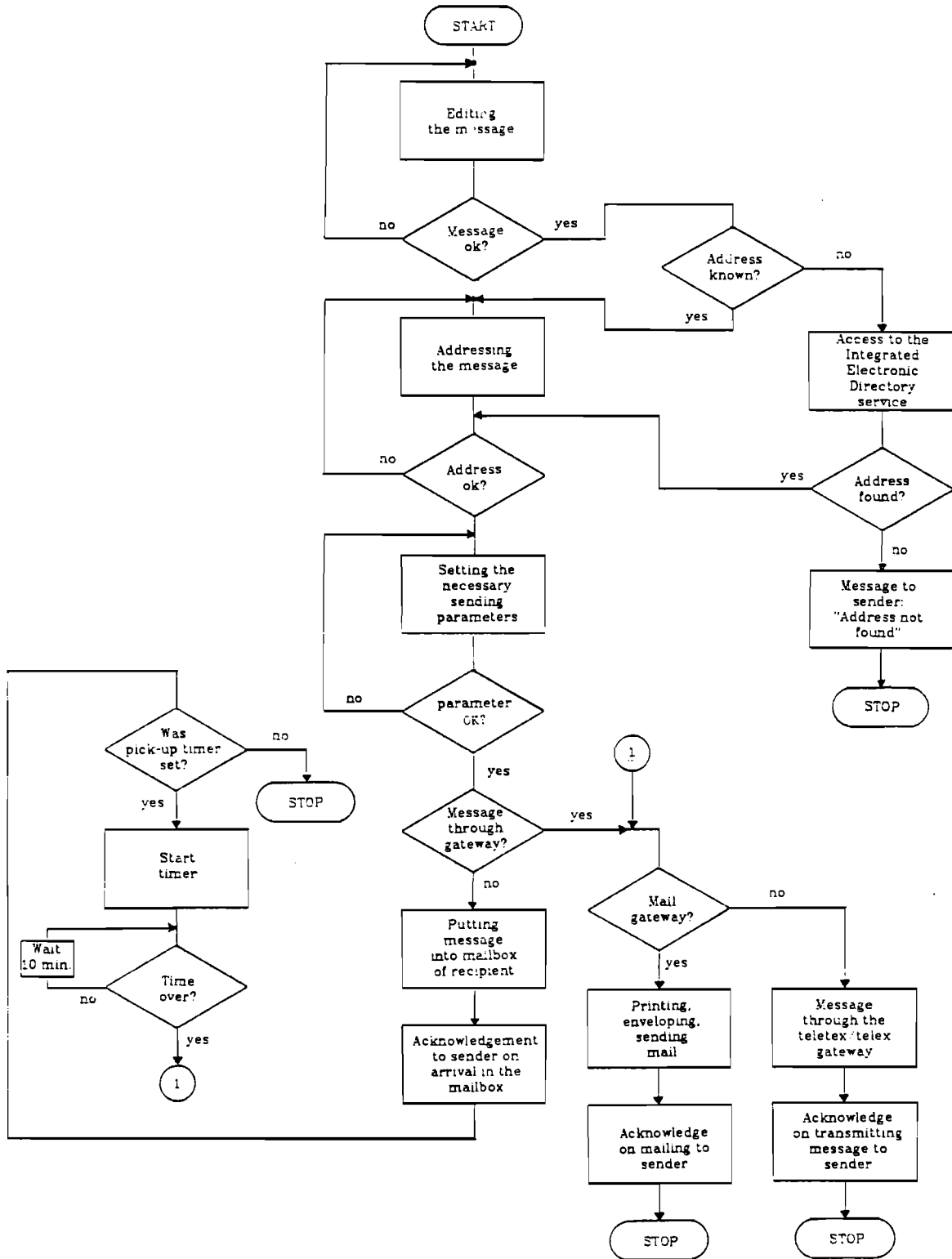

Figure 16. Flow chart of message delivery

Table 7. Sample record of the integrated electronic directory

	Record items	Keywords/Description
"White" Page Infor- mation	Record number	
	Name	
	Occupation	
	Physical address	
	1. Mailing address	
	2. Telephone number	
	3. Videotex mail box number	
	4. Telefax number	
	5. Teletex number	
	6. Telex number	
	Temporary address	
	Physical way and preference for getting message	
"Yellow" Page Infor- mation	"Private Usage Area" Description of activities (in keywords)	

(e.g., "Is the telephone number correct?") by the operator of the directory. The directory may also keep records on those participants who have only a mailing address, but no telephone, telex, telefax, etc. number; this would give the participant the option of "being known" to the public.

A "temporary address" reference could be entered by the individual-if desired-listing the location where he can be accessed during a certain future time (e.g., record number of the hotel where he is planning to stay during his holidays.)

All changes in the records would be carried out by the PTT centrally, except for notification about changes in the temporary access location and all information contained in the "private usage area" ("yellow pages"). Each subscriber would get exclusive authority to write in his own "private usage area".*

* Entries to the "yellow page" information in the form of advertisements should be charged to the subscriber. Different price schemes should apply to business organizations and private households. Advertising fees would generate additional income to the videotex service operation.

Under "physical way and preference for getting messages", first the current status of the telecommunication infrastructure would be shown from point of view of the recipient. An example is shown in Figure 17. The example shows that the communication partner in question can be accessed by mail, by telefax-based delivery service provided by the local post office, by telephone, by videotex; and a "teletex-videotex" gateway has been developed as well. Concerning way of getting written/hard-copy material, the recipient prefers mail (XXX) and messaging through videotex (XX).

Additional footnotes (e.g., "Please no telephone calls after 10 o'clock") could be placed as remarks below the matrix.

One full record would occupy maximum of three frames on a "Videotex Message Service" center. For a region of 80,000 registered addresses, for example, a disc space of 240,000 pages would be required; this is feasible, but such a system would not belong to the category of smaller systems as we presently know them. (The Austrian videotex trial is presently running on a videotex system with 50,000 pages.)

The technique of finding the piece of information requested would be carried out by "keyword" searching performed on an alphanumerical keyboard. In addition, it might be advisable for more sophisticated retrieval languages similar to those used in "professional" database management systems with logical operators, etc. to be made available as options in new generation videotex systems.

to	from	1	2	3	4	5	6
1.	Mail	XXX			X		
2.	Telephone		X				
3.	Videotex			XX		X	
4.	Telefax						
5.	Teletex						
6.	Telex						

Figure 17. Example for the telecommunication infrastructure of a given communication partner

3.3 Hardware Characteristics of Videotex Message Service Centers

Let us take as an example an area of 200,000 inhabitants, with 70,000 households (assuming 60,000 videotex terminals) and 10,000 business addresses (equipped with videotex terminals). Furthermore, let us assume a stage of full market penetration by videotex in this area.

1) Storage capacity needed

- a) *Pool of waiting messages and conference comments.* As pointed out earlier, the average number of telephone calls per household is about two call per day. Let us assume that one of these can be replaced by videotex messaging, which following a pessimistic scenario, will not be picked up on the day of arrival. A pool of an average of five waiting messages would then seem to be a reasonable estimation. Thus, the message frame @f sub m@ capacity needed is:

$$f_w = (60,000 + 10,000) \cdot 5 = 350,000$$

- b) *Message storage file.* If each user can store five messages in his private storage area:

$$f_m = 70,000 \cdot 5 = 350,000$$

- c) *Videotex teleconferencing message storage file.* Let us assume that on the average only every tenth videotex user participates in videotex conferencing and that the average group size per conference is around ten (group size may range between 2 to 100). In each conference the average of conference comments would be about 50 frames. The amount of frames needed for teleconferencing is:

$$f_t = 40,000$$

- d) *Integrated Electronic Directory.* Each "directory subject" (household or business) would have an entry of (three frames).

Thus:

$$f_d = (80,000 + 10,000) \cdot 3 = 270,000$$

- e) Thus, all frame storage capacity required (F)

$$\begin{aligned} F &= \sum f = f_w + f_m + f_t + f_d \\ &= 350,000 + 350,000 + 40,000 + 270,000 \\ &= 1,010,000 \end{aligned}$$

$$F \approx 1,000,000$$

2) Number of videotex user ports needed.

Assuming a 10 minute session per day per videotex user and assuming that access only takes place between 8 a.m. and 10 p.m. at even distribution (Figure 18), each port can serve an average of 84 users a day.

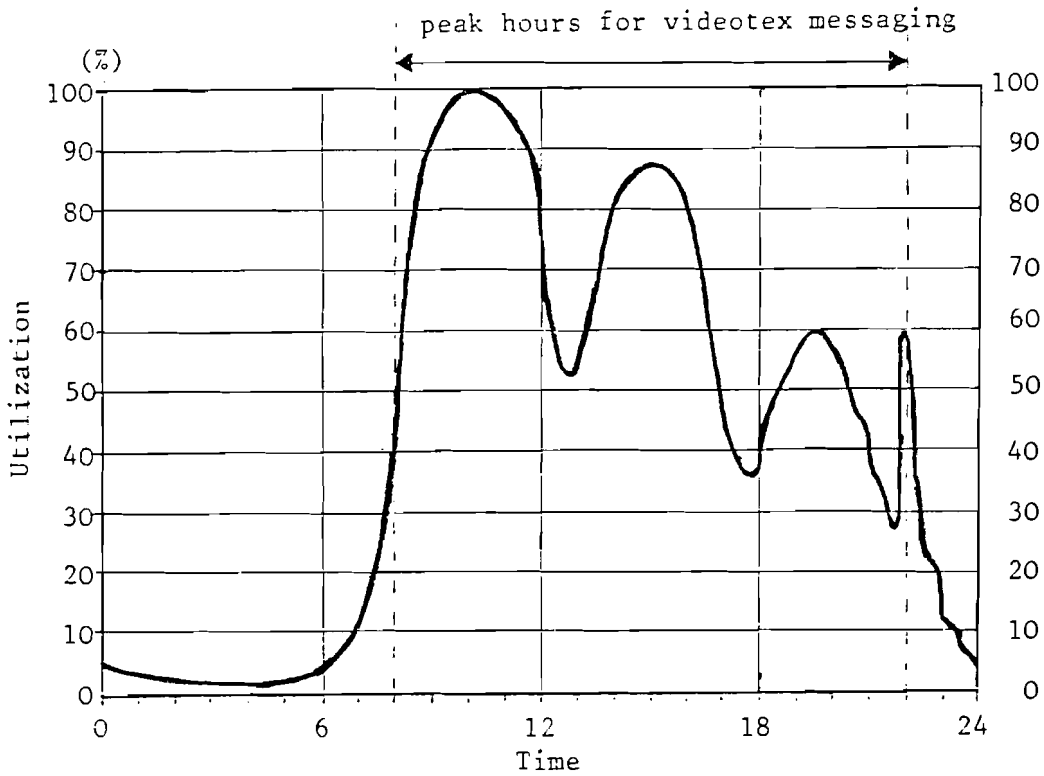

Figure 18. Utilization of the West German telephone net on a weekday in May 1975 (Telekommunikationsbericht 1976).

Thus, the number of ports (n_p) needed is:

$$n_p = \frac{70,000}{84} = 833$$

≈ 900 ports.

The above requirements can be easily fulfilled by a Videotex center computer system presently on the market (or coming on the market soon) (Table 8).

Table 8. Typical Characteristics of a Videotex Center Computer System (SEL 1981).

Number of users	2,000 - 80,000
Number of ports (including public telephone or Datex net)	75 - 2,300
Storage capacity (Videotex frames)	100,000 - 2,000,000
Maximum access time	1 sec.

3.4 Network Concept for Videotex Message Service Centers

As an example, a network is chosen which resembles to the concept of the German Bildschirmtext (see Figure 19).

A possible alternative is shown in Figure 20.

3.5 Videotex Information and Message Revenue Flows

As a commercial service, videotex--be it for information retrieval or message sending--is designed to provide service. But it also must earn profits for its supplier from the fees users should be prepared to pay. Figure 21 shows the main flows of revenues in a public videotex service.

3.6 Videotex Message Service User Guide

We have made no attempt whatsoever in this paper to design a possible videotex messaging system. Figure 22 is intended as an example of how such a system might be structured and how it might operate. It is one of many possible examples, which would vary depending on detailed design and specifications. It shows a similar but simplified design structure of the EIES system of the New Jersey Institute of Technology (Hiltz and Turoff 1978).

3.7 Economics of Videotex Messaging

A rough estimate and approximate calculation of the costs of videotex messaging are given below: US costs for the physical infrastructure (Tyler 1979) of videotex systems serving a user population of 250,000 have been estimated at about US\$ 3 million annually. UK sources (Woolfe 1980) estimate the costs of a service center, including hardware depreciation, software, operating staff, consumables, real estate, and overheads

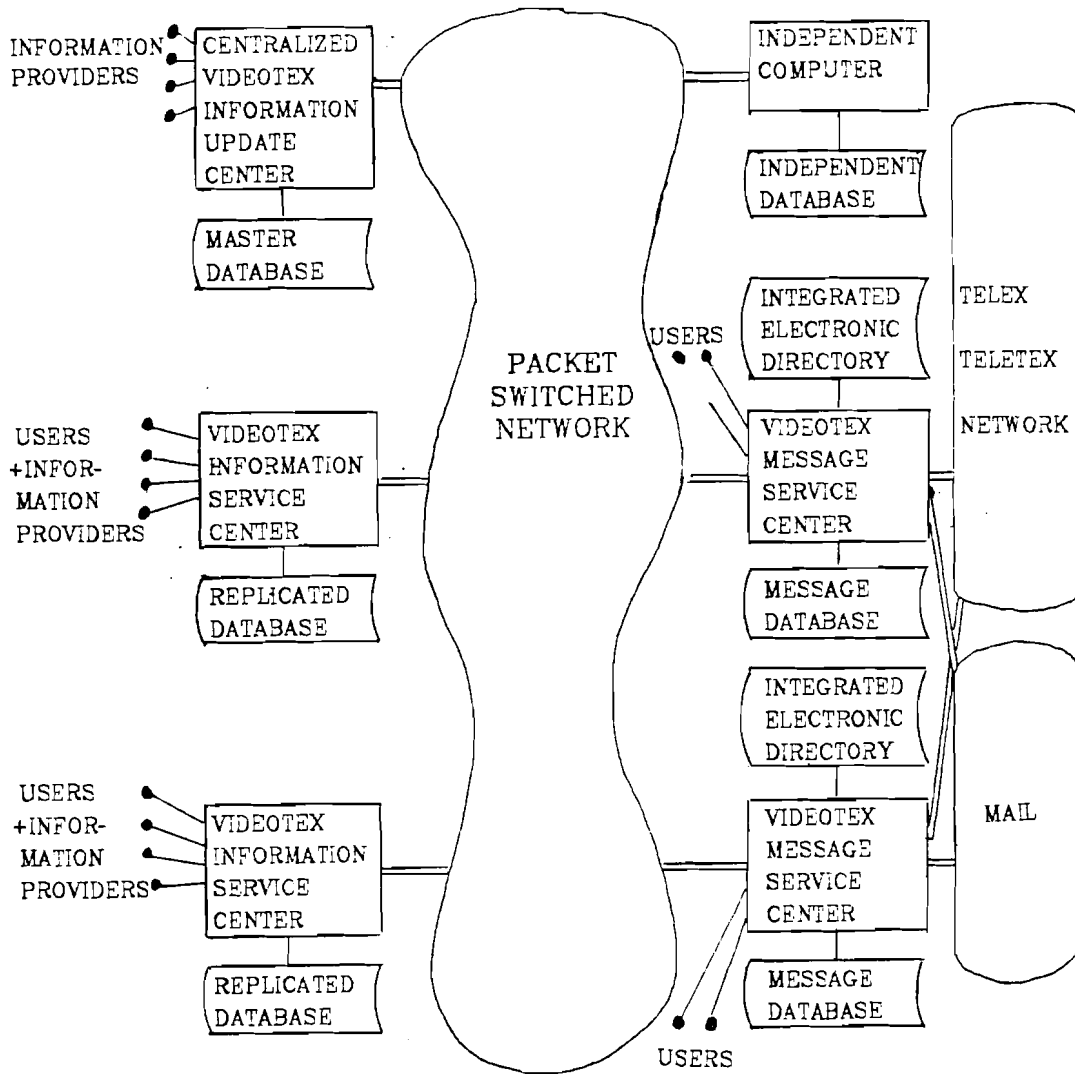
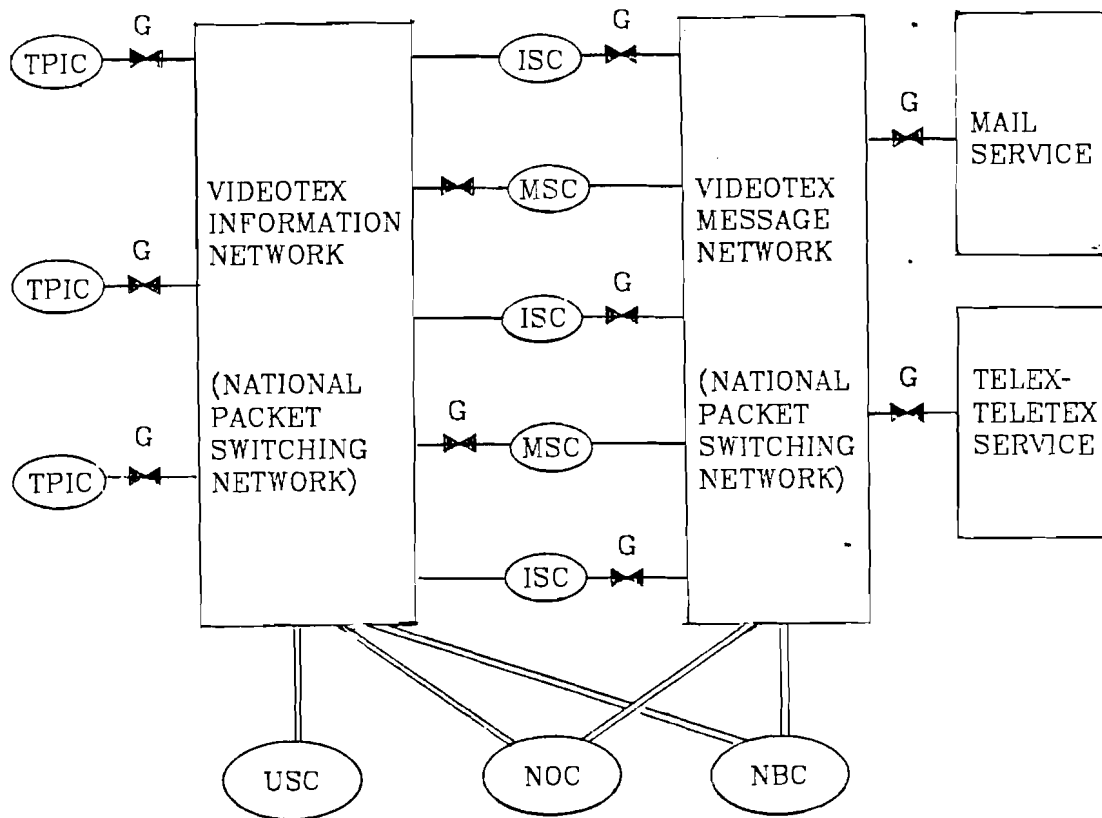

Figure 19. A possible network concept incorporating videotex messaging (version 1).



- G - Gateway
- TPIC - Third Party Information Center
- VSC - Videotex Update Service Center
- ISC - Videotex Information Service Center
- MSC - Videotex Message Service Center
- NOC - National Operating Center
- NBC - National Billing Center

Figure 20. A possible network concept incorporating videotex messaging (version 2).

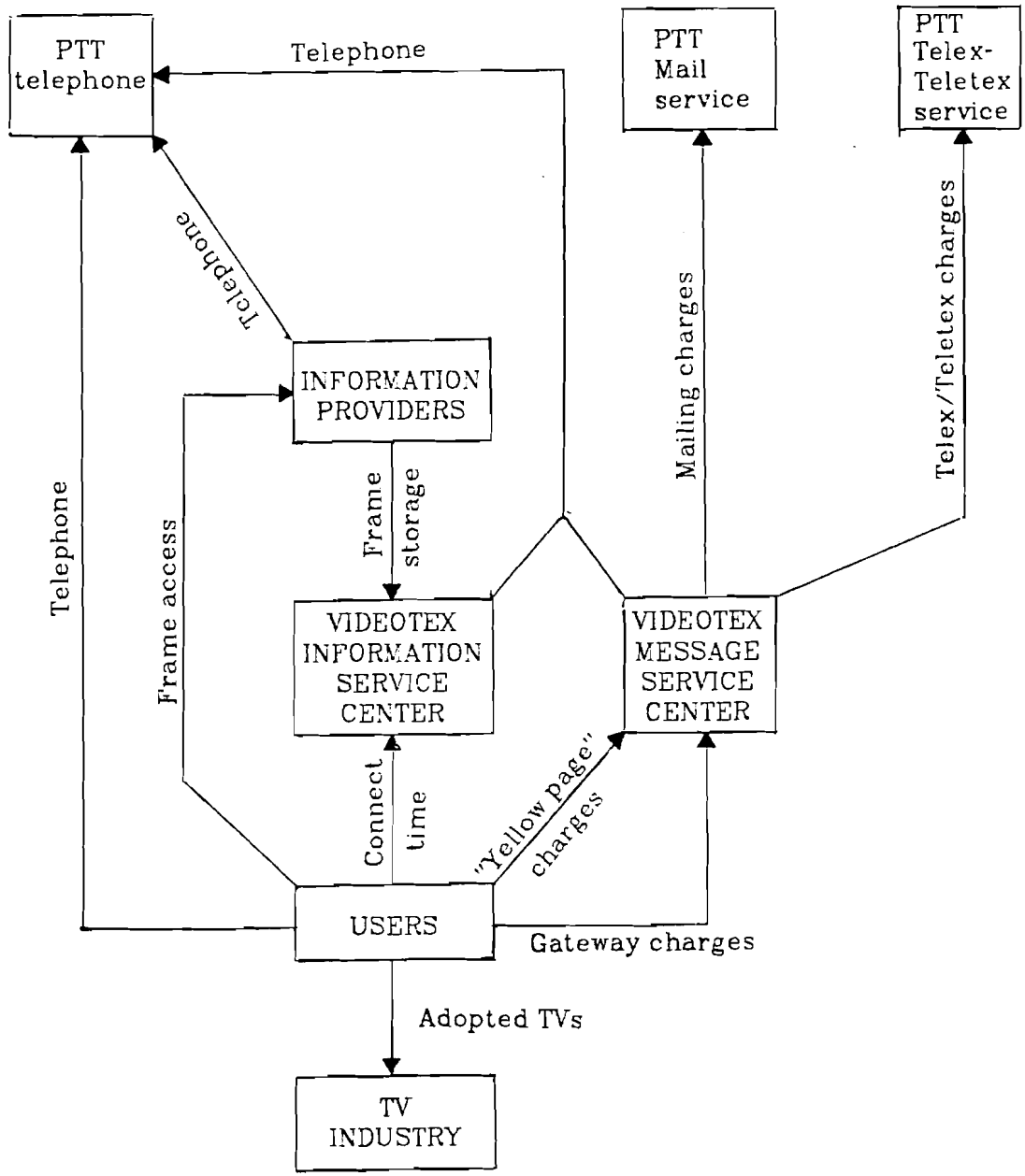

Figure 21. Flow of revenue in videotex information retrieval and messaging service.

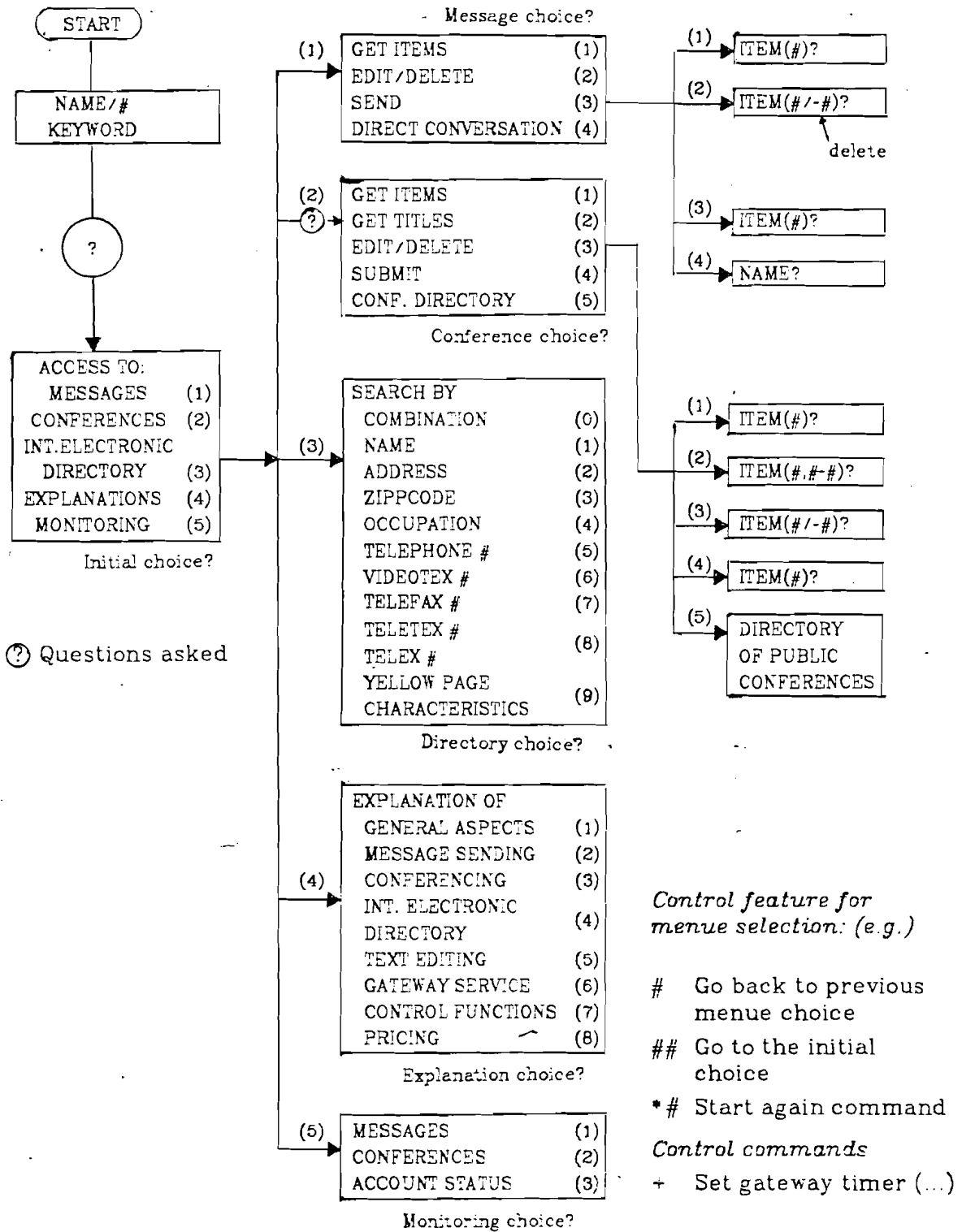

Figure 22. User guide for a possible videotex message service system.

to be about \$1 million per annum for 30,000 residential users, 300 ports and 250,000 frames of information. If we take \$3 million per annum as a starting point for an intelligent guess, we can easily calculate that with one daily access per user (looking into one's own mailbox, sending a few messages, or perhaps participating in a teleconference)--which seems to be reasonable because of the nature of the mailbox system--one user day would cost 0.12 US\$ (approx. AS 1.8), which is very low. In addition to this fixed cost, users would have to pay local telephone charges to the nearest videotex center. *The costs for using the Videotex message service center is even considerably lower than the videotex information center*, since maintenance of on-line information frames is very labor-intensive and thus expensive. *Looking at the low costs of this service, the simplest pricing policy seems to be to introduce a flat rate of 0.12 US\$ per day per user for videotex message sending service, independent of the number of messages sent by the user.* In Austria--where local telephone price are with somewhat higher--10 minutes connection time daily to the Videotex Message Sending Service would cost about AS 6. The same would cost 0.32 US\$ (approx. AS 4.8) in the UK. "Pick-up" of daily mail from the mailbox would take, say, 2 minutes at a cost in Austria of AS 2.6. With a short reply message (approximately 5 minutes connection time), this would come to AS 3.8. The prices seem even more favorable if the videotex system is based on a "national videotex network." In this case, only local telephone charges would be applied for long distance message sending.

In conclusion, it seems that videotex-supported message sending might attract a large user population. One reason will be the financial point of view.

Cost of using "gateway" services

The most reasonable policy for using gateway services seems to be to charge the regular prices for any given service which are beyond the gateway.

For example, when sending mail originating from a videotex terminal, the originator of the message should pay the cost for printing, enveloping, and physically delivering the message from the nearest videotex message center to the recipient. In most cases, this will make case, the entire process of sending the message somewhat more expensive than the simple posting of a letter, but a certain additional price has to be paid for the "value added service." The service would guarantee the delivery of the long distance mail within 24 hours and would be still cheaper than express mail.

The general policy for covering the costs of gateway services would be: Expenses should be borne by the partner who initiates the usage of the gateway service.

4. CONCLUSION

- 1) A videotex-supported message service seems to be one of the basic classes of application for interactive videotex services.
- 2) Videotex-supported messaging might substitute for a considerable amount of oral telephone conversation through its new, comfortable form of messaging in a way that would not substantially decrease traffic in the telephone network. On the contrary, through this "value added service" the PTTs could increase their total income and revenue.
- 3) Videotex-supported message services could facilitate the development and market penetration of electronic mail systems by providing terminal equipment for residential use, the absence of which is one of the hindering factors at present. The concept of gateways to other message service media, such as mail, telex, and teletex seems to be essential. In the long run videotex supported messaging and its connection to other systems may influence the other presently known message service media.

Its influence and pace of market penetration would, however, allow a smooth adoption of this new technology by the PTTs without seriously affecting the investment and labor policy of the PTT administrations, if appropriate steps were taken.

- 4) Videotex messaging service systems should be introduced with the next generation of videotex-like systems. In a number of European countries, this could take place in the next few years. For the introduction of this sort of service, however, a "critical mass" of users is required, even with the introduction of the gateway functions mentioned above.
- 5) The probability of success of videotex message service systems could first be tested in field trials. Such trials should identify how such a system would be accepted by the mass market and its possible impacts on other media.
- 6) In a similar fashion the function of teleconferencing should be tested by the mass residential user market. Videotex teleconferencing is certainly an interesting experiment which might bring a new dimension to the presently known messaging media, but which might also turn out to be superfluous.
- 7) The function of the Integrated Electronic Directory System seems to be important. This system--closely integrated into the videotex message service--would be made up of the aggregated directories of the individual messaging media. It would support "white" and "yellow" page (individual advertising) services in an integrated way.
- 8) From the technical point of view videotex message servicing as conceived in this paper can relatively easily be implemented and integrated into the presently known or planned videotex networks.

REFERENCES

- Bessant, F.R. et al. 1981. The Impact of Microelectronics--a review of the literature. London: Frances Pinter Ltd.
- Foel Stratte-Mc Clure. 1980. French Telecommunications: Digital Technology and the Telematique Program. Scientific American. September.
- Hiltz, S.R. and M. Turoff. 1978. The Network Nation--Human Communication via Computer. Reading, Mass: Addison-Wesley Publishing Company.
- Ithiel de Sola Pool, ed. 1977. The Social Impact of the Telephone. Cambridge, Mass.: The MIT Press.
- Maurer, H. 1981. Bildschirmtextaeuliche Systeme. Study prepared for the Austrian Federal Ministry for Science and Research.
- Maurer, H., W. Rauch and I. Sebestyen. 1981. Teleplaying in Videotex. IIASA Draft Working Paper (in preparation). Laxenburg, Austria: International Institute for Applied Systems Analysis.
- Rueggeber, R. 1980. Teletex--Ein neuer Internationaler textkommunikationsdienst der Fernmeldeverwaltungen. Der Fernmelde Ingenieur. Bad Windsheim: Verlag fuer Wissenschaft und Leben.

- Telekommunikationsbericht. 1976. Kommission fuer den Ausbau des technischen Kommunikationssystems (KtK), Bundesministerium fuer das Post- und Fernmeldewesen (FRG). Bonn:Bad Godesberg: Verlag Dr. Hans Heger.
- Tydeman, J. and L. Zwimpfer. 1981. Videotex in the United States--Toward Information Diversity. Prepared for the Videotex '81, Toronto, May 1981.
- Tyler, M. 1979. Videotex, Prestel and Teletext--The economics and politics of some electronic publishing media. Telecommunications Policy. March.
- US Department of Commerce. 1975. Statistical Abstracts of the United States. Washington, DC.
- US Department of Commerce. 1979. Historical Statistics of the United States Colonial Times to 1970. Washington, DC.: US Department of Commerce, Bureau of Census.
- Woolfe, R. 1980. Videotex--the new television/telephone information services. London: Heyden & Son, Ltd.
- Wurtzel, A.H. and C. Turner. 1977. Latent Functions of the Telephone: What Missing the Extension Means. In, The Social Impact of the Telephone, Ithiel de Sole Pool, ed. Cambridge, Mass.: The MIT Press.