

ÉCOLE DE TECHNOLOGIE SUPÉRIEURE
UNIVERSITÉ DU QUÉBEC

THESIS PRESENTED TO
ÉCOLE DE TECHNOLOGIE SUPÉRIEURE

IN PARTIAL FULFILLMENT OF THE REQUIREMENTS FOR
THE DEGREE OF DOCTOR OF PHILOSOPHY
Ph.D.

BY
Hedayeh MEHMANPARAST NODEHI

BIOMECHANICAL INVESTIGATION OF THE FACTORS RELATED TO PEDICLE
SCREW FIXATION STRENGTH

MONTREAL, AUGUST 04, 2015

© Copyright Hedayeh Mehmanparast Nodehi, 2015 All rights reserved

© Copyright

Reproduction, saving or sharing of the content of this document, in whole or in part, is prohibited. A reader who wishes to print this document or save it on any medium must first obtain the author's permission.

BOARD OF EXAMINERS (THESIS PH.D.)

THIS THESIS HAS BEEN EVALUATED

BY THE FOLLOWING BOARD OF EXAMINERS

Mr. Yvan Petit, Thesis Supervisor
Department of Mechanical Engineering at École de technologie supérieure

Mr. Jean-Marc Mac-Thiong, Thesis Co-supervisor
Department of surgery at University of Montreal

Mrs. Nicola Hagemeister, Chair, Board of Examiners
Department of Automated Manufacturing Engineering at École de technologie supérieure

Mr. Eric Wagnac, Member of the jury
Department of Mechanical Engineering at École de technologie supérieure

Mr. Sofiane Achiche, Independent External Evaluator
Department of Mechanical Engineering at École Polytechnique de Montréal

THIS THESIS WAS PRESENTED AND DEFENDED

IN THE PRESENCE OF A BOARD OF EXAMINERS AND PUBLIC

IN JUNE 09, 2015

AT ÉCOLE DE TECHNOLOGIE SUPÉRIEURE

DEDICATION

*This thesis is dedicated to my loving parents and my beloved spouse
for their love, endless support
and encouragements.*

ACKNOWLEDGMENTS

The last few years of my life have been the most challenging and rewarding because I truly had the opportunity to meet and understand people from many different countries who enriched my life by sharing a wide range of customs and cultural backgrounds. I am deeply grateful to all my advisors that opened my eyes and guided my steps in the long and winding road to the fantastic world of biomechanics.

I would like to express my sincere gratitude to my advisors, Dr. Yvan Petit and Dr. Jean-Marc Mac-Thiong for the opportunity they have given me to work at the laboratory of medical imaging and orthopedics (LIO) as well as Orthopedics and Trauma research center at Sacré-Coeur hospital of Montreal. Without their thrust, guidance, patience and supports, my research would not have been successful. I hope the bond that we established will continue for many years to come. My immense appreciation extends to Dr. Eric Wagnac, Dr. Sofiane Achiche and Dr. Nicola Hagemester for serving as members of jury of my Ph.D. defense committee and for providing valuable comments.

I appreciate Natural Sciences and Engineering Research Council of Canada (NSERC) and Canada research Chair in Engineering Innovations in Spinal Trauma for their financial support for this project. Special thanks go to Depuy Spine and Canada foundation for innovation for providing the experimental tools and equipment. Sincere thanks are extended to my colleagues at LIO and Sacré-Coeur hospital of Montreal for their discussions and assistance in different parts of this research project.

I wish to give my wholehearted thanks to my parents for their unwavering supports, kind words, well-wishing and patience for abiding by my absence. Special thanks go to my beloved spouse for his support, encouragement and patience and for lifting much of the burden of life during the final stages of this thesis. Finally, I express my deep feelings to my God for giving me the will to do this work.

BIOMECHANICAL STUDY OF PEDICLE SCREW FIXATION

Hedayeh MEHMANPARAST NODEHI

RÉSUMÉ

Les pathologies et les traumatismes de la colonne vertébrale peuvent compromettre gravement la qualité de vie des patients. L'intervention chirurgicale est souvent réalisée en utilisant des dispositifs de fixation internes. La fixation à l'aide de vis pédiculaires est une méthode bien établie qui assure une bonne stabilité du rachis post-instrumentation. Cependant, ce type de fixation est associé à des taux d'échec de complications qui peuvent représenter une préoccupation majeure, surtout avec l'avenue de nouvelles techniques chirurgicales plus agressives. De nombreuses études expérimentales ont été consacrées à l'évaluation de la résistance des fixations par vis pédiculaires. Les méthodes d'évaluation incluent la mesure de la densité minérale osseuse, des essais expérimentaux de mesure du couple d'insertion des vis et des essais de traction jusqu'à la rupture. La densité minérale de l'os a été utilisée pour estimer la force ultime d'extraction des vis pédiculaires. Plusieurs études ont aussi indiqué que le couple d'insertion de la vis peut prédire la solidité de fixation des vis pédiculaires alors que d'autres études ont trouvé le contraire. Cette controverse illustre la nécessité d'améliorer la compréhension des facteurs liés à la résistance des fixations par vis pédiculaires. De plus, les mécanismes de relâchement des vis pédiculaires affectant la rigidité de fixation et conduisant à l'échec demeurent mal compris.

L'objectif principal de cette thèse est de mieux comprendre les mécanismes de relâchement des vis pédiculaires et les facteurs biomécaniques liés à la solidité de fixation des vis pédiculaires. Cet objectif est relié à deux hypothèses, soient : 1) la force d'indentation appliquée lors du perçage du trou pilote dans l'os vertébral et le couple d'insertion des vis pédiculaire sont reliés à la force d'arrachement des vis et à la rigidité de fixation; 2) un chargement cyclique de flexion des vis pédiculaires dans les directions craniocaudale (CC) et médio-latérale (ML) provoquent un relâchement des vis pédiculaire affectant la force d'arrachement et la rigidité de fixation.

Trois objectifs spécifiques ont été définis pour vérifier ces hypothèses en utilisant deux protocoles expérimentaux. Le premier objectif spécifique est de développer et valider des outils de mesure de la force de pénétration lors du perçage du trou pilote et du couple d'insertion des vis pédiculaires. Le deuxième objectif est de comparer les mécanismes de relâchement des vis pédiculaires par flexion selon différents modes et d'évaluer leur effet sur la force d'arrachement et la rigidité de fixation des vis. Enfin, le troisième objectif est d'établir les relations entre la force d'indentation, le couple d'insertion, la force d'arrachement et la rigidité de fixation des vis pédiculaires.

Le premier protocole a été réalisé sur des échantillons d'os synthétique afin d'atteindre principalement le premier objectif spécifique. Dans ce protocole, des échantillons de trois densités différentes ont été utilisées pour faire des essais de traction des vis jusqu'à

l'arrachement avec et sans chargement cyclique en flexion a priori. Cinq répétitions ont été réalisées pour chaque essai pour un total de 36 essais réalisés dans ce premier protocole. Les relations potentielles entre la force d'indentation et le couple d'insertion des vis avec la force d'arrachement et la rigidité ont été investigués. Le second protocole a été effectué sur des vertèbres porcines pour atteindre les deuxième et troisième objectifs spécifiques. Trois modes de chargement en flexion (CC, ML et aucun (NT)) ont été effectués sur 27 vertèbres lombaires (L1 à L3) porcines. Les vis ont ensuite été soumises à un essai de traction axiale jusqu'à l'arrachement. Le résultat est un plan d'expérience complet à deux facteurs et trois niveaux ($3^2 = 9$ essais) permettant d'étudier l'effet du mode flexion cyclique et du niveau vertébral sur la force d'arrachement des vis et leur rigidité de fixation, ainsi que leurs interactions quadratiques. Avec cinq répétitions, un total de 54 essais ont été effectués en utilisant les deux pédicules de chaque vertèbre. Enfin, des régressions linéaires multiples ont été investiguées entre la force d'indentation du trou pilote, le couple d'insertion des vis, la force d'arrachement et la rigidité de fixation des vis avec et sans flexion a priori.

Les résultats du premier protocole suggèrent que le chargement cyclique en flexion des vis affecte significativement la force d'arrachement ($P = 0,01$) et la rigidité de fixation ($P < 0,0001$) des vis pédiculaires. De plus, une force de traction et une rigidité plus élevées ont été démontrées pour les échantillons de plus grande densité lorsqu'aucun chargement cyclique de flexion n'est appliqué. L'effet de la densité est plus élevé que l'effet du chargement en flexion sur la force d'arrachement des vis. La force de pénétration lors du perçage du trou pilote est significativement corrélée avec la force d'arrachement ($r = 0,99$, $P < 0,0001$) et la rigidité de fixation ($r = 0,92$, $P < 0,0001$). De fortes corrélations ont également été obtenues entre le couple d'insertion de la vis et la force d'arrachement ($r = 0,98$, $P < 0,0001$) et la rigidité de fixation ($r = 0,91$, $P < 0,0001$).

L'étude sur les vertèbres porcines a montré que le chargement en flexion cyclique de la vis pédiculaire affecte significativement la force d'arrachement ($P = 0,0004$) et la rigidité de fixation ($P < 0,0001$). La force d'arrachement et la rigidité la plus faible ont été illustrées pour la flexion cranio-caudale (CC) tandis que les plus élevés ont été observés sans flexion (NT). L'effet du niveau vertébral sur la force d'arrachement est plus élevé que l'effet du chargement en flexion de la vis. Une force de traction plus faible et une plus grande rigidité de fixation des vis ont été observées au niveau des vertèbres L3. L'effet du chargement en flexion est plus important sur la rigidité de fixation que sur la force d'arrachement pour chaque niveau vertébral. Des différences significatives ont été observées sur la force d'arrachement des vis pédiculaires entre les modes de flexion CC et NT ($P = 0,03$) et entre CC et ML ($P = 0,02$). Pour la rigidité de fixation des vis, des différences significatives ont été observées entre tous les modes de chargement en flexion (CC et NT: $P < 0,0001$, ML et NT: $P = 0,0002$, CC et ML: $P = 0,0003$). La force d'indentation, le couple d'insertion et de la densité osseuse présentent des corrélations importantes avec la force d'arrachement avec ou sans chargement en flexion des vis ($0,71 < r < 0,88$). La force d'indentation, le couple d'insertion et de la densité osseuse présentent d'importantes corrélations négatives ($-0,60 < r < -0,85$) avec la rigidité de fixation des vis pour les chargements en flexion CC et NT. Les analyses de régressions multiples ont montré que la densité osseuse et le couple d'insertion des vis permettent d'estimer la force de d'arrachement après flexion cyclée CC ou ML ($R^2 >$

0,85, $P < 0,0001$). Pour la force d'arrachement sans chargement cyclique des vis, la densité osseuse et l'aire des pédicules sont les principaux facteurs qui contribuent au modèle de régression. La force d'indentation lors du perçage du trou pilote est le meilleur prédicteur de la rigidité de fixation des vis avec et sans chargement en flexion.

En conclusion, le chargement cyclique en flexion affecte significativement la force d'arrachement des vis pédiculaires et leur rigidité de fixation dans l'os. Le chargement cyclique en flexion, en particulier dans la direction cranio-caudale, devrait être considérée dans l'évaluation biomécanique de la fixation à l'aide de vis pédiculaires. De plus, la contribution du chargement en flexion est plus importante pour évaluer la rigidité de fixation que la force d'arrachement des vis pédiculaires. L'effet de niveau vertébral devrait aussi être considéré dans l'évaluation de la fixation par vis pédiculaires. Les outils et les méthodes développés dans ce projet pour mesurer la force d'indentation lors du perçage du trou pilote et le couple d'insertion des vis pédiculaires fournissent des données précieuses et reproductibles pour estimer la force d'arrachement et la rigidité de fixation des vis pédiculaires. La relation entre la force d'indentation, le couple d'insertion des vis, la force d'arrachement et la rigidité de fixation des vis est affectée par le mode de chargement en flexion des vis. Il est donc recommandé de mesurer la force d'indentation, le couple d'insertion des vis pédiculaires et la densité minérale osseuse pour évaluer la fixation vertébrale à l'aide de vis pédiculaires.

Mots-clés: biomécanique, colonne vertébrale, vis pédiculaire, mécanismes de relâchement, chargement cyclique en flexion, rigidité de fixation, force d'indentation, couple de serrage à l'insertion, densité minérale osseuse.

BIOMECHANICAL STUDY OF PEDICLE SCREW FIXATION

Hedayeh MEHMANPARAST NODEHI

ABSTRACT

Spinal pathologies or injuries can severely compromise the quality of life for the patients. The surgical intervention is often performed using internal fixation devices. Fixation with pedicle screws is a well-established method providing spinal stability and deformity correction. However, reported rates of fixation failure because of screw loosening have become a major concern, especially with the appearance of new and more powerful surgical techniques. Numerous experimental studies have been devoted to pedicle screw fixation strength evaluation. The evaluation methods are commonly including preoperative measurements of bone mineral density, screw insertional torque measurement and pullout tests. Bone mineral density measurement gives only to some extent an estimation of the pedicle screw fixation strength. Several studies indicated that the screw insertional torque measurement can provide predictive information on the fixation strength. However, the latter was not confirmed by other studies. This controversy illustrates the need for improving the understanding of factors related to pedicle screw fixation strength. In addition, there is a need for better understanding the mechanisms of pedicle screw loosening leading to failure and their effects on the fixation strength.

The main objective of this doctoral thesis was to improve the understanding on the mechanisms of pedicle screw loosening and the factors related to pedicle screw fixation strength. This objective is related to two hypotheses: 1) the indentation force measured while performing the pilot hole and the torque observed during screw insertion are related to the screw pullout force and stiffness; 2) cyclic bending load (toggling) on pedicle screw in craniocaudal (CC) and mediolateral (ML) directions loosens the screw and affects the pullout force and stiffness.

Three specific objectives were defined to verify the hypotheses using two experimental protocols. The first specific objective was to develop and validate tools measuring the indentation force while performing the pilot hole and the insertional torque during pedicle screw insertion. The second objective was to compare the screw loosening mechanisms through toggling in different modes and evaluate their effects on pedicle screw pullout force and stiffness. Finally, the third objective was to establish the relationships between the indentation force, the insertional torque and the screw pullout force and stiffness.

The first protocol was performed on synthetic bone surrogates mainly to explore the first specific objective. Furthermore, to account for the effect of various bone densities and toggling modes on pullout force and stiffness, pedicle screw were pulled out with and without toggling from synthetic bone surrogates of three different densities. With five repetitions, a total of 36 trials have been completed. Finally, potential relationships between

the indentation force and the insertional torque with the pullout force and stiffness were explored. The second protocol was performed on porcine vertebrae to investigate the second and the third specific objectives. As the second specific objective, three toggling modes (CC, ML and no toggling (NT)) were performed on porcine lumbar vertebrae ranging from L1 to L3. The screws were then submitted to axial pullout test. A complete design of experiment with two factors and three levels ($3^2 = 9$ trials) was used to investigate on the main effect of toggling mode and vertebral level on screw pullout force and stiffness, as well as their quadratic interactions. With five repetitions, a total of 54 trials were performed on 27 isolated vertebrae, using both pedicles. Finally, potential relationships were investigated between the indentation force while performing a pilot hole, the insertional torque during screw insertion, and the pullout force and stiffness with and without toggling.

The results of the first protocol suggest that screw toggling significantly affects the pullout force ($P = 0.01$) and stiffness ($P < 0.0001$). A higher pullout force and stiffness was demonstrated for higher density without toggling. The effect of density was higher than the effect of toggling on pullout force. The indentation force while performing the pilot hole was significantly correlated to pullout force and stiffness ($r = 0.99$, $P < 0.0001$ and $r = 0.92$, $P < 0.0001$ respectively). Strong correlations were also shown between the insertional torque during screw insertion and the pedicle screw pullout force and stiffness ($r = 0.98$, $P < 0.0001$ and $r = 0.91$, $P < 0.0001$ respectively).

The study on porcine vertebrae showed that screw toggling significantly affects the pullout force ($P = 0.0004$) and stiffness ($P < 0.0001$). The lowest pullout force and stiffness were illustrated for CC toggling while the highest ones were shown without toggling (NT). The effect of vertebral level on pullout force was higher than the effect of toggling. Lower pullout force and higher stiffness were observed at anatomically lower vertebra level (L3). The effect of toggling was more important on the stiffness than the pullout force at all vertebral levels. Significant differences in pullout force were shown between CC toggling and no toggling ($P = 0.03$) and between CC and ML toggling ($P = 0.02$). For the stiffness, significant differences were shown between all toggling modes (CC and NT: $P < 0.0001$, ML and NT: $P = 0.0002$, CC and ML: $P = 0.0003$). The indentation force, the insertional torque and the BMD had the highest important correlations with pullout force with and without toggling ($0.71 < r < 0.88$). For the stiffness after CC toggling and with no toggling, the indentation force, the insertional torque and the BMD had the most important negative correlations ($-0.60 < r < -0.85$). Multiple regression analysis showed that BMD and insertional torque improve the estimation of pullout force after CC or ML toggling ($R^2 > 0.85$, $P < 0.0001$). For pullout force without toggling BMD and pedicle area were the main contributing factors to the regression model. For the stiffness with and without toggling, the indentation force was the single best factor with highest contribution to the regression model.

In conclusion, pedicle screw toggling significantly affects the pedicle screw pullout force and stiffness. Screw toggling, in particular CC toggling, should be considered in the biomechanical evaluation of pedicle screw fixation strength. Furthermore, the contribution of toggling was more important on the stiffness than the pullout force. The effect of vertebral level should be considered in determining the fixation strength. The developed instruments

and methods for indentation force measurement during pilot hole creation and insertional torque measurement during screw insertion were reproducible, and provide valuable data to estimate pedicle screw pullout force and stiffness. The relationship between the pilot hole indentation force and screw insertional torque, and the screw pullout force and stiffness are affected by the toggling mode. Indentation force and insertional torque measurements, together with BMD measurement, are recommended for a better estimation of pedicle screw fixation strength after CC toggling.

Keywords: biomechanics, spine, pedicle screw, loosening mechanism, screw toggling, fixation strength, indentation force, insertional torque, bone mineral density.

TABLE OF CONTENTS

	Page
INTRODUCTION	1
CHAPTER 1 LITERATURE REVIEW	3
1.1 Human spine	3
1.1.1 Functional anatomy of the spine	3
1.1.2 Specific anatomy of vertebrae	6
1.1.3 Vertebral bone quality	8
1.1.4 Vertebral bone mechanical properties	15
1.2 Porcine spine	19
1.2.1 Functional anatomy of porcine spine	19
1.2.2 Bone quality of porcine vertebrae	21
1.2.3 Use of porcine specimens in spinal research	21
1.3 Synthetic bone surrogates	22
1.4 Spinal fixation using pedicle screws	24
1.4.1 Prevalence and success	24
1.4.2 Pedicle screws	25
1.4.3 Pedicle screw fixation technique	30
1.4.4 Supplemental techniques to pedicle screw fixation	33
1.5 Biomechanical evaluation of pedicle screws fixation	34
1.5.1 Complications associated with pedicle screw fixation	34
1.5.2 Factors governing the fixation strength	35
1.5.3 Test methods to measure pedicle screw fixation strength	36
CHAPTER 2 HYPOTHESIS AND OBJECTIVES	43
2.1. Hypotheses and specific objectives	44
CHAPTER 3 MATERIALS AND METHODS	45
3.1 Method overview	45
3.2 Protocol 1: Experimental study on synthetic bone surrogates	46
3.2.1 Synthetic bone surrogates preparation	47
3.2.2 Experimental apparatus	47
3.2.3 Mechanical testing	49
3.2.3.1 Indentation test	50
3.2.3.2 Insertional torque measurement	51
3.2.3.3 Toggling test	52
3.2.3.4 Pullout test	53
3.2.3.5 Data analysis	54
3.3 Protocol 2: Experimental study on porcine vertebrae	55
3.3.1 Specimens preparation	56
3.3.2 Experimental apparatus	57
3.3.3 Biomechanical testing	58

	3.3.3.1	Indentation test.....	58
	3.3.3.2	Insertional torque measurement.....	60
	3.3.3.3	Toggling test.....	61
	3.3.3.4	Pullout test.....	62
	3.3.3.5	Data analysis.....	63
CHAPTER 4	RESULTS.....		65
4.1	Experimental study on synthetic bone surrogates.....		65
	4.1.1	Indentation force, screw insertional torque, pullout force and stiffness with and without toggling.....	65
	4.1.2	Effects of toggling mode and density on pullout force and stiffness.....	69
	4.1.3	Relationships between indentation force and insertional torque with pullout force and stiffness.....	74
4.2	Experimental study on porcine vertebrae.....		74
	4.2.1	Specimen characteristics.....	75
	4.2.2	Indentation force, screw insertional torque, pullout force and stiffness with and without toggling.....	75
	4.2.3	Effect of toggling mode and vertebral level on pullout force and stiffness.....	79
	4.2.4	Relationships between vertebral intrinsic properties and measurements during screw insertion with pullout force and stiffness.....	84
CHAPTER 5	DISCUSSION.....		87
CONCLUSION.....			95
RECOMMENDATIONS.....			97
APPENDIX I	CONFERENCE ARTICLE 1: ESTIMATION OF PEDICLE SCREW FIXATION STRENGTH FROM PROBE INDENTATION FORCE AND SCREW INSERTION TORQUE: A BIOMECHANICAL STUDY ON BONE SURROGATE OF VARIOUS DENSITIES.....		99
APPENDIX II	CONFERENCE ARTICLE 2: BIOMECHANICAL EVALUATION OF PEDICLE SCREW LOOSENING MECHANISM USING SYNTHETIC BONE SURROGATE OF VARIOUS DENSITIES.....		107
APPENDIX III	CONFERENCE ARTICLE 3: IN VITRO EVALUATION OF PEDICLE SCREW LOOSENING MECHANISM: A PRELIMINARY STUDY ON ANIMAL MODEL.....		117
APPENDIX IV	JOURNAL ARTICLE1: COMPARISON OF PEDICLE SCREW LOOSENING MECHANISMS AND THEIR EFFECT ON FIXATION STRENGTH.....		119
BIBLIOGRAPHY.....			141

LIST OF TABLES

		Page
Table 3.1	Sequential steps of biomechanical testing for protocol 1	50
Table 3.2	Sequential steps of protocol 2	58
Table 4.1	Mean \pm SD of indentation force and insertional torque for the three densities.....	66
Table 4.2	Mean \pm SD of toggled and non-toggled pullout force and stiffness for PU foam blocks of various densities from different studies, Asterisk (*) denotes range of values obtained for various screw designs	69
Table 4.3	Significance of the effect of density and toggling mode on the pullout force and stiffness, asterisk (*) denotes as significant effect.....	71
Table 4.4	Relationships between indentation force and insertional torque with pullout force and stiffness	74
Table 4.5	Mean values of the pedicle area (Ped.A), height (Ped.H), width (Ped.W) and the vertebral trabecular density (BMD).....	75
Table 4.6	Mean \pm SD of maximum indentation force and insertional torque at the three vertebral levels	77
Table 4.7	Mean \pm SD of Pullout force and stiffness for different toggling modes at the three vertebral levels.....	79
Table 4.8	Significance of the effect of vertebral level and toggling mode on the pullout force and stiffness. Asterisk (*) denotes as significant effect	81
Table 4.9	Correlations and significance levels of different measured variables with pullout force after CC, ML and NT toggling.....	84
Table 4.10	Correlations and significance levels of different measured variables with stiffness after CC, ML and NT toggling.	85

LIST OF FIGURES

		Page
Figure 1.1	Anatomical planes and directions (Adapted from DePuy Synthes (2013))	4
Figure 1.2	Lateral view of the human spine (Adapted from Anatomy Body Gallery (2009)).....	5
Figure 1.3	Anatomic terms describing the spinal motions (Taken from Kurtz and Edidin (2006)).....	6
Figure 1.4	Anatomy of cervical, thoracic and lumbar vertebrae (Taken from Kentucky Community and Technical College System (2014))	8
Figure 1.5	Factors influencing the bone quality (Taken from Sardone (2011)).....	9
Figure 1.6	Cortical bone and trabecular bone of vertebra (Taken from Sardone (2011)).....	11
Figure 1.7	Age-related changes in trabecular bone: (A) normal and (B) osteoporotic bone.....	13
Figure 1.8	Mechanical properties from load vs. displacement plot (Adapted from Sardone (2011)).....	16
Figure 1.9	Mechanical properties from stress vs. strain plot (Adapted from Sardone (2011)).....	16
Figure 1.10	Schematic anatomy of porcine spine	20
Figure 1.11	Axial and lateral profiles of a lumbar vertebra from (a) pig and (b) human.....	20
Figure 1.12	Comparison of interbody device subsidence in: (a) Polyurethane foam block, (b) custom-made synthetic vertebra, (c) human vertebra (Taken from Au et al. (2011)).....	23
Figure 1.13	Pedicle screw types: (a) Polyaxial and (b) Monoaxial Pedicle Screw (Adapted from DePuy Synthes (2013))	25
Figure 1.14	Difficulty in rod-screw alignment using MA pedicle screws in curve correction (Taken from Wang et al. (2011)).....	26

Figure 1.15	Improving configuration in curve correction using PA pedicle screws.....	26
Figure 1.16	Overview of pedicle screw parameters	28
Figure 1.17	Pedicle screw thread designs:	29
Figure 1.18	Pedicle screw insertion technique.....	31
Figure 1.19	Pedicle screw trajectories:.....	32
Figure 1.20	Pedicle screw insertion orientations:	33
Figure 1.21	Strengthening the pedicle screw-	34
Figure 1.22	Typical force-displacement curve from a pullout test (Adapted from Mehta et al. (2011)).....	37
Figure 1.23	Indentation measurement tool (left), Torque measurement tool (right). ...	40
Figure 3.1	Methodological approach.....	46
Figure 3.2	Custom-made fixture for biomechanical testing allows alignment of specimen with the cross-head axis of the material testing machine	48
Figure 3.3	Custom-made indenter	48
Figure 3.4	Custom-made test bench for pedicle screw insertion	49
Figure 3.5	Experimental apparatus used for pilot hole creation into synthetic bone specimen.....	51
Figure 3.6	Pedicle screw insertion into synthetic bone specimen.....	52
Figure 3.7	Material testing system, test fixture and load frame for (a) toggling test and (b) pullout test in synthetic bone specimens	53
Figure 3.8	Anatomical dimensions measured for individual pedicles of each porcine vertebra	57
Figure 3.9	Entry point and hole trajectory for individual pedicles	59
Figure 3.10	Test fixture allowing lateral rotation.....	60
Figure 3.11	Custom-made test bench for screw insertion in porcine vertebra.....	61
Figure 3.12	Material testing system and test fixture configurations for (a) CC and (b) ML toggling	62

Figure 3.13	Test fixture and configuration of the pullout test on porcine specimens.....	63
Figure 4.1	Typical curves of indentation force as a function of indentation depth for the three different densities	66
Figure 4.2	Typical curves of insertional torque as a function of screw insertion depth at the three different densities	67
Figure 4.3	Typical curves of pullout force as a function of displacement for toggled and non-toggled screws.....	68
Figure 4.4	Pareto charts for the significance of the effect of toggling mode and density on: (a) pullout force, (b) stiffness	70
Figure 4.5	3D response surface plot of: (a) pullout force, (b) stiffness	72
Figure 4.6	Comparison of toggled and non-toggled screws in three densities for: (a) pullout force, (b) stiffness. Asterisk (*) denotes a significant difference	73
Figure 4.7	Typical graph of indentation force versus indentation depth for porcine vertebrae	76
Figure 4.8	Typical graph of insertional torque as a function of insertion depth for porcine vertebrae	77
Figure 4.9	Typical graph of pullout force as a function of displacement	78
Figure 4.10	Pareto chart for the significance of the effect of toggling mode and vertebral level on: (a) Pullout force, (b) stiffness	80
Figure 4.11	2D contour plot of (a) pullout force (b) stiffness.....	82
Figure 4.12	Comparison of the effects of toggling modes on: (a) pullout force, (b) stiffness. Asterisk (*) denotes a significant difference	83

LIST OF ABBREVIATIONS

AN	Anatomic trajectory
ANOVA	Analysis of variance
ASTM	American society for testing and materials
BMC	Bone mineral content
BMD	Bone mineral density
BSE	Back-scatter electron imaging
BV/TV	Bone volume fraction
CI	Confidence interval
Conn.D	Connective density
CC	Craniocaudal toggling
CT	Computed tomography
DA	Degree of anisotropy
DEXA	Dual energy x-ray absorptiometry
DOF	Degree of freedom
FEA	Finite element analysis
MA	Monoaxial pedicle screw
MDCT	Multi-detector row CT
ML	Mediolateral toggling
MRI	Magnetic resonance imaging
NT	No toggling
PA	Polyaxial pedicle screw
Ped.A	Pedicle area
Ped.H	Pedicle height
Ped.W	Pedicle width
PMMA	Polymethylmethacrylate
PU	Polyurethane

QCT	Quantitative computed tomography
SD	Standard deviation
SF	Straight-forward trajectory
Tb.N	Trabecular number
Tb.Sp	Trabecular spacing
Tb.Th	Trabecular thickness

LIST OF SYMBOLS AND UNITS OF MEASUREMENTS

Symbol	Units	Description
σ_f	MPa	Failure stress
F_f	N	Failure load
A_{cs}	mm ²	Cross-sectional area
ϵ_f	%	Failure strain
δ_f	mm	Displacement at failure
h_v	mm	Height of the specimen
E	MPa	Young's modulus
K	N/mm	Stiffness
P	-	P-value
R^2	-	Coefficient of determination
r	-	Pearson's correlation coefficient
F_{PCC}	N	Pullout force after CC toggling
F_{PML}	N	Pullout force after ML toggling
F_{PNT}	N	Pullout force without toggling
F_I	N	Indentation force
F_T	Nm	Insertional torque
P_A	mm ²	Pedicle area
S_{CC}	N/mm	Stiffness after CC toggling
S_{NT}	N/mm	Stiffness without toggling

INTRODUCTION

Spinal fixation using pedicle screws is currently the standard surgical treatment for spinal fractures, degenerative changes, or deformities. The effectiveness of pedicle screw constructs in facilitating fusion, shorter-segment instrumentation, restoring the spinal stability, and improving the realignment has been demonstrated extensively (Gaines Jr, 2000). The functional benefits for patients includes pain relief, faster healing time and decrease the postoperative management strategies. However, complications associated with pedicle screws failure have been reported in many cases. Failures in osteoporotic spines are of particular importance since the insufficient integrity at screw-bone interface may lead to screw loosening and pullout (Dickman et al., 1992; Esses, Sachs and Dreyzin, 1993; Sanden et al., 2004).

Numerous biomechanical studies tried to estimate pedicle screw fixation strength through pullout to optimize the clinical intervention strategies. Axial pullout test is considered as the standard evaluation method of pedicle screw stability. However, it is not likely the physiological mode of failure. A better understanding of screw loosening mechanisms is needed for comprehensive investigation of the fixation strength. Some other research groups investigated the factors contributing to implant fixation strength through in vitro, in vivo and numerical studies. These factors include screw design, insertion technique, orientation, pedicle morphology, bone mineral density and in some cases the screw insertional torque. Though, the relationship between the insertional torque and pullout force is not evident. Therefore, there is a need to improve the understanding of factors related to pedicle screw fixation strength during pilot hole creation or screw insertion.

The objective of this doctoral project is to improve the understanding of the mechanisms of pedicle screw loosening and the factors related to pedicle screw fixation strength. To this end, development of instruments to measure the indentation force while performing the pilot hole and the insertional torque during screw insertion is required. Moreover, it is intended to study the mechanisms of pedicle screw loosening from multidirectional loadings and their

effects on the fixation strength. Thereby, the relationships between indentation force and insertional torque and pullout force with various loosening modes are established. To minimize the inter specimen variation and the anatomical constraints of cadaveric bones, synthetic bone models will be used to validate the developed instruments for indentation force and insertional torque measurement. Subsequently, the loosening mechanisms and factors related to the fixation strength will be investigated on porcine vertebrae, which present less inter-individual variability and regional BMD than human vertebrae.

This thesis is divided into five chapters. Chapter 1 presents a literature review of the human spine anatomy, the porcine spine anatomy, and the use of synthetic bone surrogates in biomechanical research. Pedicle screw-based spinal fixation and biomechanical evaluation of pedicle screw fixation are also discussed. Relevant previous studies to measure pedicle screws fixation strength are described at the end of this section. The problematic associated with the review of literature, hypotheses and specific objectives are discussed in Chapter 2. Chapter 3 describes the methodological approach to verify the hypotheses and reach the objectives. Chapter 4 presents the experimental results and statistical analyses. Discussions on the obtained results, validity and relevance of this doctoral project is given in chapter 5. Finally, some concluding remarks and recommendations will be presented.

CHAPTER 1

LITERATURE REVIEW

1.1 Human spine

1.1.1 Functional anatomy of the spine

Anatomical planes and directions

The human body is usually described in three principal anatomical planes located perpendicular reciprocally (Figure 1.1). The *sagittal plane* divides the body into left and right halves vertically. The *coronal (frontal) plane* discriminates the front and back of the body and the *axial (transverse) plane* is allocated to upper and lower halves of the body. Figure 1.1 also demonstrates the anatomical reference directions that are often used in clinical vocabulary. The *medial* direction is toward the midline of the body while the *lateral* direction is away from the middle of the body. The *anterior* direction points toward the front of the body whilst *posterior* direction is referred to as the back of the body. The *superior* direction refers to upper part of the body and the downward direction is *inferior*. The *proximal* and *distal* directions are used for individual limbs and are referred to as the direction toward a reference point and away from a reference point respectively. The *cranial (cephalad)* direction which points toward the head and *caudal* direction that implies to the lower end of the body, are referred directions for the spine.

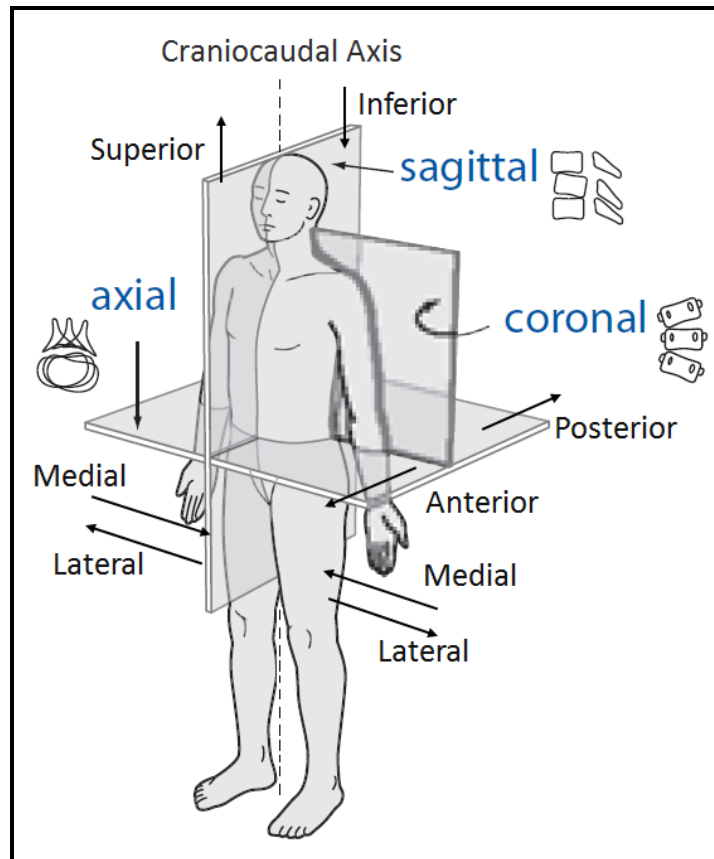

Figure 1.1 Anatomical planes and directions
(Adapted from DePuy Synthes (2013))

Spinal regions

The human spine normally consists of 24 vertebrae. The spinal segments from cranial toward caudal direction are described as follows: seven cervical vertebrae (C1-C7), twelve thoracic vertebrae (T1-T12), five lumbar vertebrae (L1-L5), five sacral fused vertebrae (S1-S5), and three to four coccygeal vertebrae (Figure 1.2). The healthy spine appears straight and symmetrical in frontal view. The sagittal or lateral view of the healthy spine typifies four normal curves. There are anteriorly convex curves in cervical and lumbar regions while in thoracic and sacral regions the curvatures are posteriorly convex. This S-shaped anatomical curvature gives increased flexibility and shock-absorbing capacity to the spinal column and maintains adequate stiffness and stability at intervertebral joint level. The anatomical

curvatures provide specific biomechanical functions: they absorb part of the superior-inferior forces and increase the flexibility of the spine while reducing intervertebral constraints.

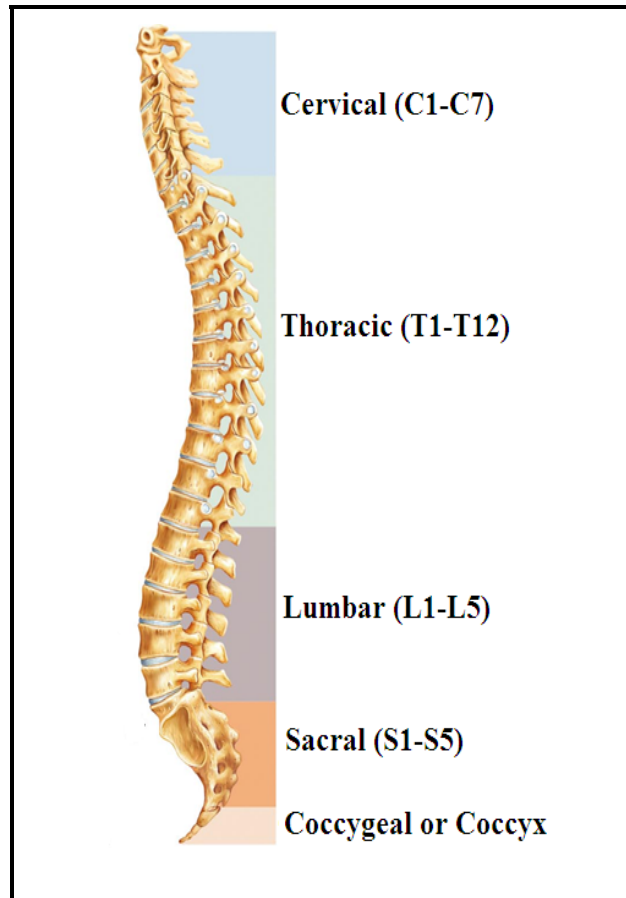

Figure 1.2 Lateral view of the human spine
(Adapted from Anatomy Body Gallery (2009))

Spinal motion

Figure 1.3 describes the movements of the spine. The anatomical terms such as *extension* and *flexion* referred to as posterior and anterior bending respectively. Bending the spine away from the sagittal plane of the body is termed *lateral bending*. Rotation of the spine along its longitudinal axis is referred as *axial torsion*. Axial displacement of the spine due to a tensile

load or muscles forces that actuate the spine's ligaments is called *traction* (Kurtz and Edidin, 2006).

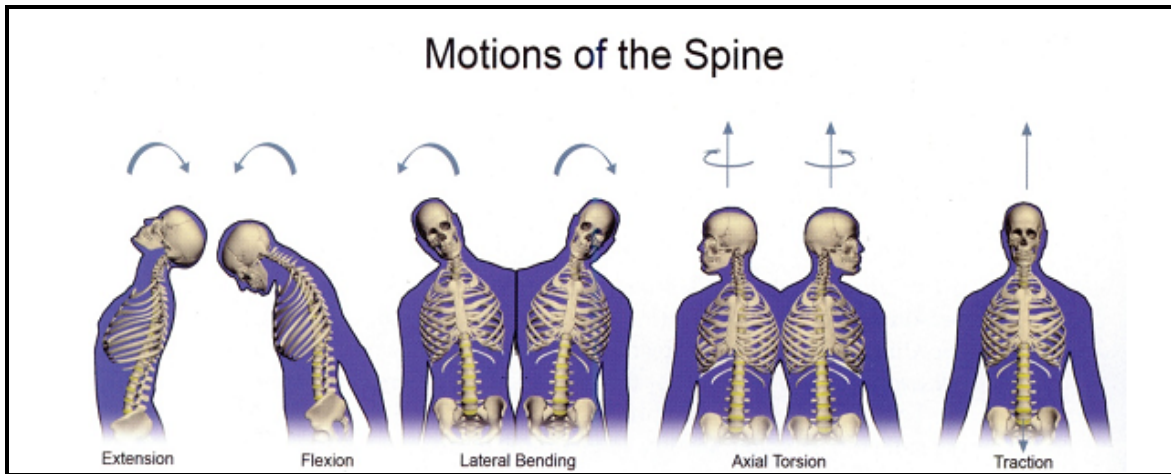

Figure 1.3 Anatomic terms describing the spinal motions
(Taken from Kurtz and Edidin (2006))

The direction and type of applied load on the spine during different activities is generally a combination of axial (compression or tension), bending or torsional forces (Silva, 2007). The prediction of compressive forces on thoracolumbar spine from mathematical models indicate that forward flexion and increasing weight at a distance from the body's center of mass increases the load (Katonis et al., 2003). For instance, it has been reported that the load acting on L2 in relaxed standing is 0.5 times body weight and it can increase up to 1.5 times body weight in 30° forward flexion of the trunk. The force magnitude will increase even more when lifting weights which can lead to a high risk of injury for a person of average size and height with poor bone quality (Pihlajamäki, Myllynen and Böstman, 1997).

1.1.2 Specific anatomy of vertebrae

Figure 1.4 illustrates the typical anatomy of cervical, thoracic and lumbar vertebrae. A vertebra is divided in two main parts: the *vertebral body* in anterior part and the *vertebral arch* in posterior part of the vertebra. The vertebral body has a cylindrical shape with a

slightly concave superior and inferior ends (*endplates*). The vertebral arch is composed of two *pedicles* and two *laminae*. The vertebral arch and the posterior wall of the vertebral body form the *vertebral foramen*. The assembly of vertebral foramen makes the spinal canal through which the spinal cord is inserted. The spinal nerves are emerged from the spinal canal through intervertebral foramens which are confined by the pedicles of adjacent vertebrae. Seven processes are associated with the vertebral arch: two *transverse processes*, four *articular processes* and one *spinous process*. The posterior elements which contribute to protect the spinal cord and restrict motion are joined to the vertebral body via the pedicles. Pedicles play a significant role in transferring the load of torsion, transverse shear, and extension (Bogduk, 2005).

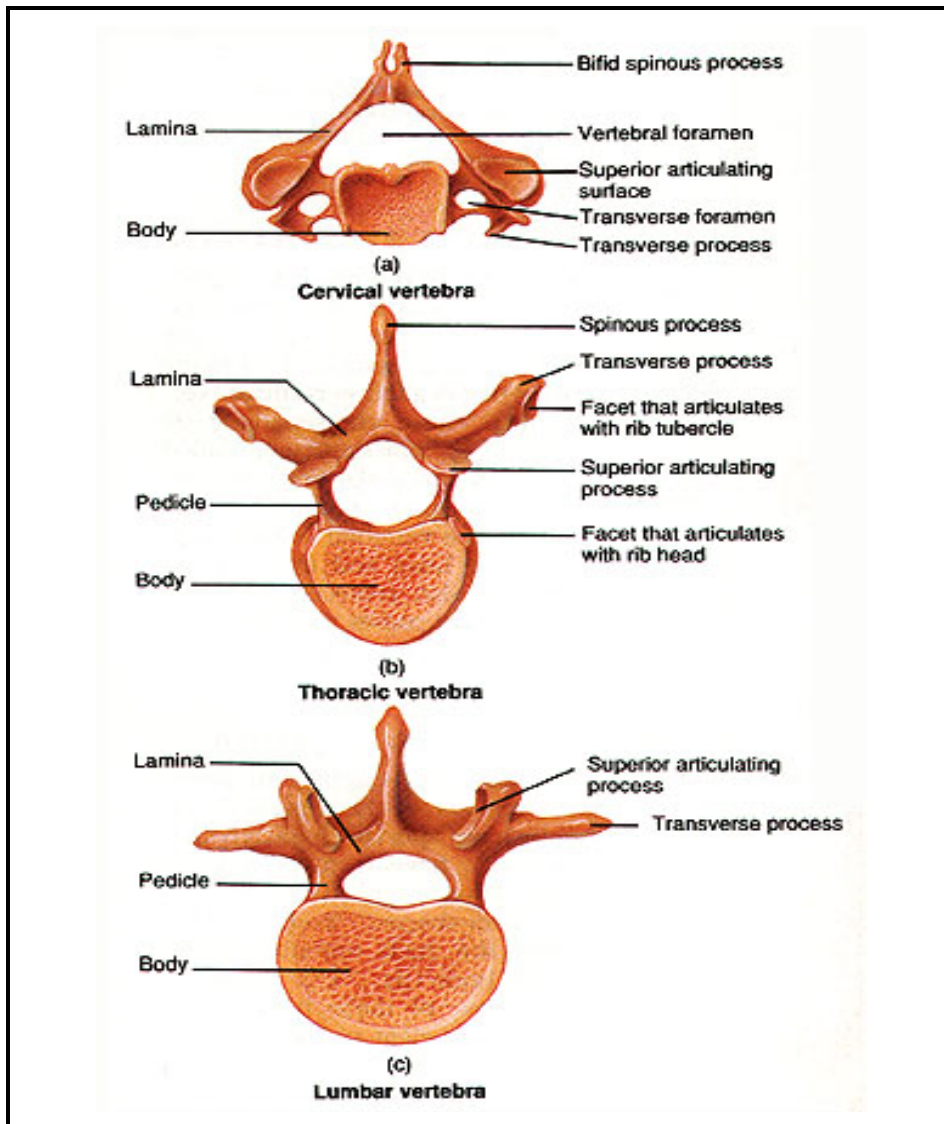

Figure 1.4 Anatomy of cervical, thoracic and lumbar vertebrae
(Taken from Kentucky Community and Technical College System (2014))

1.1.3 Vertebral bone quality

Bone quality is a term that includes all of the material and structural properties of bone that mutually contribute to the bone mineral density and mechanical properties (Grynpas, Chachra and Lundon, 2000; Heaney, 1993) (Figure 1.5). The bone material properties (mineralization) and structural properties (architecture and connectivity) are both influenced

by the process of bone remodeling. An evaluation of bone quality is necessary to adequately predict bone strength or the fracture risk (Briggs, Greig and Wark, 2007; Silva, 2007). Furthermore, to estimate the spinal implant fixation strength and the risk of fixation failure, determination of bone quality is a preliminary necessary step.

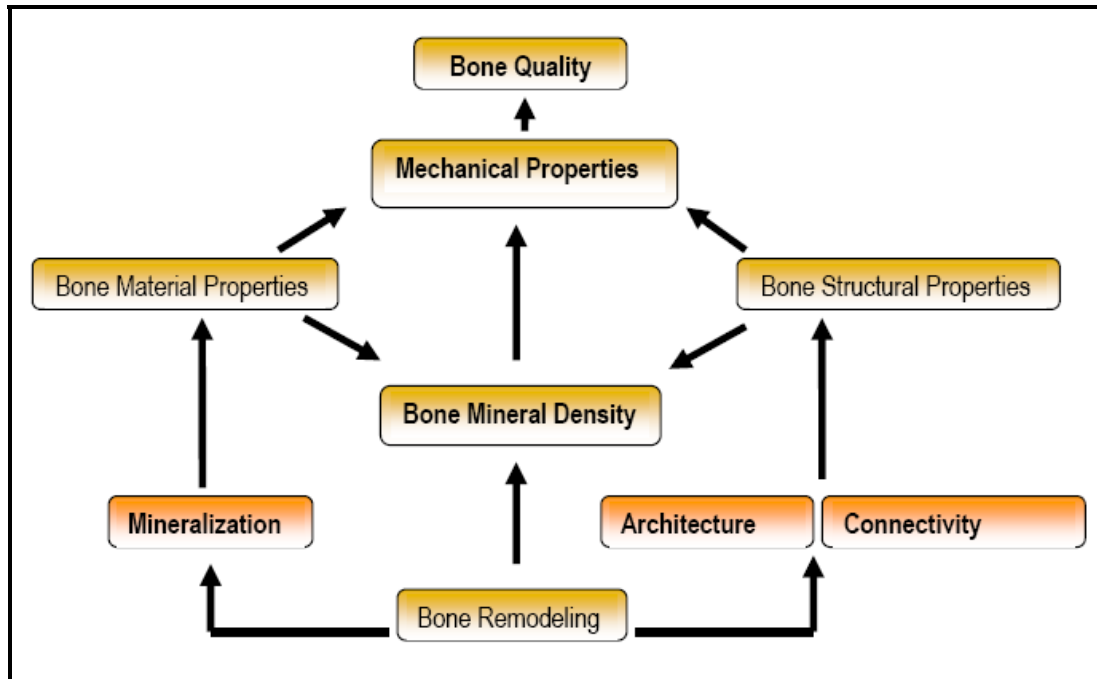

Figure 1.5 Factors influencing the bone quality
(Taken from Sardone (2011))

Bone material

Bone is composed of three main components, bone cells, organic matrix and mineral. The bone cells include osteoblasts, osteocytes and osteoclasts. These cells are responsible for the bone remodeling process and their regulation is very important. The matrix consists of collagen and noncollagenous proteins. The mineral component is dominantly formed from hydroxyapatite ($\text{Ca}_{10}(\text{PO}_4)_6(\text{OH})_2$) (Cowin, 2001).

Bone mineral density

Bone mineral density (BMD) is often measured using dual energy x-ray absorptiometry (DEXA). This technique applies x-rays with low radiation dose and provides a two-dimensional image to measure the amount of bone minerals projected in a given area (Nagy, Prince and Li, 2001). Osteoporosis which is a metabolic skeletal disorder affecting the bone density and structure is clinically assessed using DEXA. According to world health organization criterion, a T-score less than -2.5 is diagnosed for osteoporosis, a T-score less than -1.0 and greater than -2.5 is defined for osteopenia, and a T-score of -1.0 or higher denotes a normal healthy bone (Carballido-Gamio and Majumdar, 2006). BMD measurement using DEXA has for disadvantage its inability to reveal the heterogeneity in distribution of BMD within the vertebral body. It is likewise inefficient in monitoring the therapeutic interventions for osteoporosis and unable to discriminate BMD difference in osteoporotic individuals with and without fracture (Briggs, Greig and Wark, 2007). Thus, quantitative computed tomography (QCT) is used to measure the volumetric BMD. The QCT also enables to quantify the age related morphological changes in trabecular bone and provides the information to discriminate fractured and non-fractured osteoporotic bones (Briggs, Greig and Wark, 2007).

Bone mineral content

The review of previous investigations (Briggs, Greig and Wark, 2007) demonstrates that BMD measurement only accounts for 70-90% of the variance in vertebral bone strength and gives indirect evidence of the local bone strength. Therefore, the remaining variance is defined by other contributors to bone quality. Bone strength is dependent on structural and material (mineralization) properties which are all influenced by bone remodeling (Ammann and Rizzoli, 2003). The quality of the mineral phase of bone remodeling is an important contributor to mechanical strength. Back-scatter electron imaging (BSE) evaluates the bone mineral content (BMC). BSE generates a distribution of mineralization values over a cross-section of bone area. These measurements allow for the determination of the age of the

mineral distribution as well as the amount of homogeneity in a given area (Grynepas, Chachra and Lundon, 2000). A study by Hansson and Roos (1980) examined vertebral BMC and found a linear relationship between decreasing BMC with increasing age. Another study by Hansson and Roos (1980) demonstrated a significant correlation between BMC and mechanical strength.

Bone structure

The vertebral bone is composed of two distinct tissue types: cortical (or compact) bone in the periphery and trabecular (or cancellous) bone in the center of the vertebra (Figure 1.6). The trabecular bone extends from the vertebral body into the posterior elements through the pedicles. The cortical bone with a dense structure and load bearing function is composed of layers of bone matrix (lamellae) which form cylindrical column structures (haversian systems). Trabecular bone consist of a network of interconnecting struts (trabeculae) through which the blood vessels pass and is filled by bone marrow. The trabecular bone structure provides an energy absorbent function during compressive loading while being lightweight (Seeman, 2002).

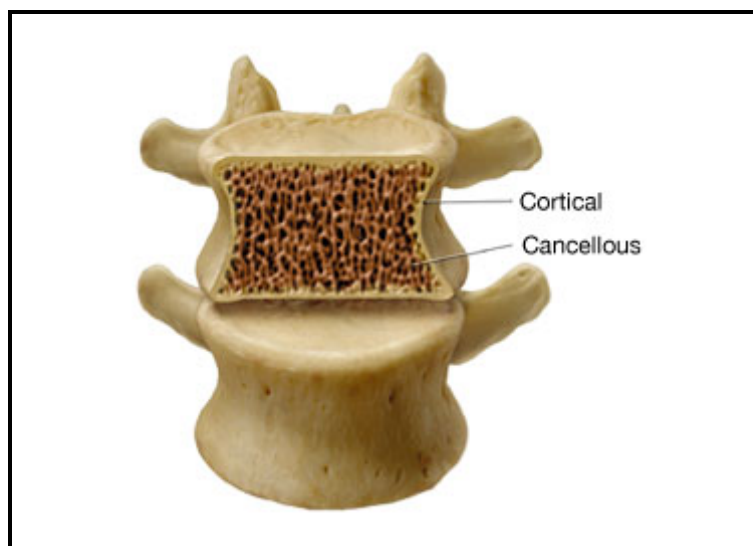

Figure 1.6 Cortical bone and trabecular bone of vertebra
(Taken from Sardone (2011))

Microstructural properties

Microstructure of the trabecular bone is characterized by morphological parameters. These parameters are often computed in regions of interest in the selected image modality and the most often observed can be listed as follows (Carballido-Gamio and Majumdar, 2006):

- Bone volume fraction (bone volume/total volume, BV/TV);
- Trabecular thickness (Tb.Th);
- Trabecular spacing (Tb.Sp);
- Trabecular number (Tb.N);
- Connective density (Conn.D);
- Degree of anisotropy (DA).

Figure 1.7 illustrates the age-related changes in trabecular bone. The pattern of bone loss in normal aging process is reflected from microstructural parameters. Loss of trabecular bone leads to more widely separation of remaining trabeculae and less connectivity which results in reduced resistance to a compressive force (Gordon et al., 1998).

A study by Hulme, Boyd and Ferguson (2007) have investigated the variation in microstructure of the vertebral trabecular bone and its relationship with fracture strength. They have shown the most important microstructural parameters that have shown the best correlation with failure strength are BV/TV and Conn.D. Microstructural parameters have also indicated significant differences in individuals with and without vertebral fracture (Briggs, Greig and Wark, 2007; Ito et al., 2005). The corresponding changes are: increased Tb.Th, increased Tb.Sp, decreased Conn.D and decreased Tb.N. The loss of trabecular connectivity is inversely proportional to microdamage. Thus, fatigue and accumulation of microdamage in trabeculae will decrease the bone toughness and increase the fracture risk. Microstructural anisotropy of the trabecular bone causes the bone loss of strength in directions other than primary axis of loading (Briggs, Greig and Wark, 2007).

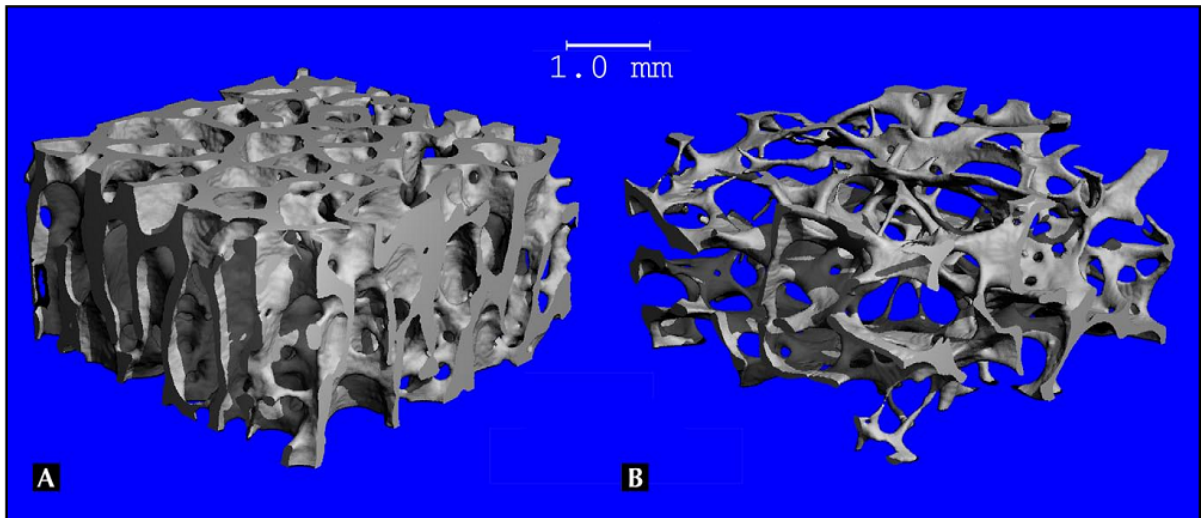

Figure 1.7 Age-related changes in trabecular bone: (A) normal and (B) osteoporotic bone
Taken from Carballido-Gamio and Majumdar (2006)

Microstructural evaluation of trabecular bone is performed using the following imaging techniques:

- **Computed tomography (CT)**

Individual trabeculae cannot be depicted using conventional CT scanners (in-plane spatial resolution of $400\ \mu\text{m} \times 400\ \mu\text{m}$). They can only demonstrate the structural texture (e.g. rough versus smooth, homogeneous versus heterogeneous, high versus low orientation of trabecular distribution) (Ito et al., 2005);

- **Spiral CT**

Microstructural information can be achieved by modification in image acquisition (higher spatial resolution) using spiral CT scanner. However, the main limitation of this technique is that achieving higher spatial resolution results in the higher radiation dose (Carballido-Gamio and Majumdar, 2006);

- **Multi-detector row CT (MDCT)**

MDCT has higher spatial resolution than spiral CT (in-plane spatial resolution of $250\ \mu\text{m} \times 250\ \mu\text{m}$ and minimum slice thickness of $500\ \mu\text{m}$). It has a high radiation exposure but is acceptable for once a year study (Ito et al., 2005). Further improvements to MDCT such

as reduction in radiation dose, higher resolution, higher signal to noise ratio, adding finite element analysis for assessment of biomechanical properties are expected to make it more useful technique (Ito et al., 2005);

- **Micro-CT**

It is a three-dimensional imaging modality with very high isotropic spatial resolution ($6 \mu\text{m}^3$ to $100 \mu\text{m}^3$). Although individual trabeculae are depicted using micro-CT, it cannot be used in vivo on humans. The in-vivo version of micro-CT apparatus is a high resolution (isotropic spatial resolution up to $82 \mu\text{m}^3$) peripheral QCT (pQCT) which can only scan lower and upper extremities (legs and arms) (Carballido-Gamio and Majumdar, 2006);

- **Magnetic resonance imaging (MRI)**

It is a non-ionizing radiation imaging modality that originates from interaction of an atom and external magnetic field. The atom should have odd number of protons or neutrons and nuclear spin angular momentum. The most abundant atom which has sensitive spin in biological imaging is hydrogen. Hydrogen is usually present in tissue water. Since the bone has very low water content, it doesn't give a strong signal to visualize the microstructure. However, if the marrow surrounding trabeculae is imaged at high spatial resolution, the trabecular network is revealed. MRI is usually used at peripheral sites (e.g. calcaneus, tibia, radius) and the spatial resolution is $156 \mu\text{m} \times 156 \mu\text{m} \times 500 \mu\text{m}$. It cannot be used for axial skeleton due to the motion artefacts and the problems with signal to noise ratio which decreases as spatial resolution increases (Carballido-Gamio and Majumdar, 2006). The disadvantage of high resolution MRI is the long acquisition time (Ito et al., 2005).

The spatial resolutions in MRI and QCT are not high enough to depict individual trabeculae. Therefore, this limitation in spatial resolution leads to partial volume effect in resulting image. Partial volume effect occurs when a single voxel of image contains signals from multiple tissue types, and results in voxel intensity to be the average signal from various tissues. Thus, the corresponding trabecular parameters from these imaging modalities are called apparent (Carballido-Gamio and Majumdar, 2006). To increase image quality, image

processing patterns are often used. These patterns attempt to differentiate the bone marrow from trabeculae which can improve the signal-to-noise ratio and contrast-to-noise ratio.

1.1.4 Vertebral bone mechanical properties

Both material and structural properties of the bone affect its mechanical behavior. Bone mechanical properties such as stiffness and strength can be evaluated through mechanical testing up to failure (Turner, 2002). The data obtained from these tests are used to construct load-displacement curves from which mechanical properties are derived. Direct mechanical testing of bone specimens provides useful information regarding bone strength and fragility that cannot be assessed BMD measurement alone. A load-displacement curve provides information about the relationship between the load applied to a specimen and the resulting deformation in response to that load (Figure 1.8). The mechanical properties that are most commonly obtained from a load-displacement curve are: stiffness, failure load and energy to failure. Failure load represents the maximum load at which the bone ultimately breaks. Stiffness is determined from the slope of the linear part of the curve.

A specimen can undergo either compressive, tensile or shear force depending on the direction/orientation of the applied load. Load and deformation can be converted to stress and strain (Figure 1.9) which eliminates the effects of shape of specimens and other extrinsic properties on bone strength (Turner, 2002). The information obtained from the stress-strain curve is comprised of: young's modulus, yield stress, failure stress and toughness.

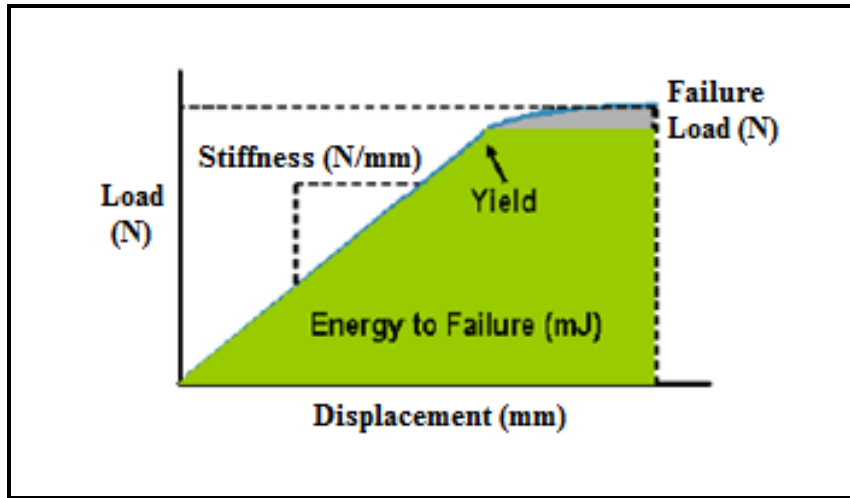

Figure 1.8 Mechanical properties from load vs. displacement plot
(Adapted from Sardone (2011))

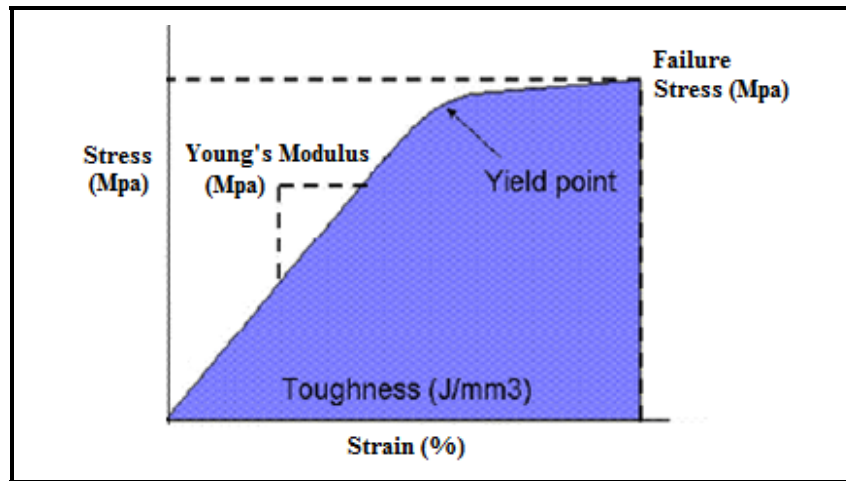

Figure 1.9 Mechanical properties from stress vs. strain plot
(Adapted from Sardone (2011))

Failure stress indicates the maximum amount of stress that bone can withstand. The stress and strain at failure are calculated using Equations 1.1 and 1.2 respectively:

$$\sigma_f = \frac{F_f}{A_{cs}} \quad (1.1)$$

Where: σ_f is failure stress (MPa), F_f is failure load (N) and A_{cs} is cross-sectional area (mm^2).

$$\varepsilon_f = \frac{\delta_f}{h_v} \times 100 \quad (1.2)$$

Where: ε_f is failure strain (%), δ_f is displacement at failure and h_v is Height of the specimen.

Toughness is a measure of the amount of energy per unit volume that bone specimens can absorb without fracture and is calculated from the total area under the stress-strain curve. The toughness indicates both strength and ductility of the material. Young's modulus is determined from the slope of the elastic region of the stress-strain curve and is calculated using Equation 1.3:

$$E = \frac{h_v}{A_{cs}} K \quad (1.3)$$

Where: E is young's modulus (MPa), h_v is height of the specimen (mm), A_{cs} is cross-sectional area (mm^2), and K is stiffness (N/mm).

Cortical bone mechanical properties

It is understood from the review of literature (Silva, 2007) that the cortical bone strength and toughness decrease more significantly than elastic properties with age. These declines in material properties with age are best explained by morphological and compositional changes in cortical bone tissue (Silva, 2007). When bone remodeling is unbalanced (i.e. resorption outpaces formation), cortical bone with more holes is resulted. This increase in bone porosity contributes to its loss of stiffness, strength. BMC or ash fraction is another factor related to bone mechanical properties. Bone mineralization increases during growth and maturation which cause decrease in bone toughness. However, the increasing mineralization role in age-related fracture strength is unclear after age 35 (maturation). Increase in non-enzymatic cross

linking of bone collagen also cause decrease in strength of organic matrix leading to loss of bone strength and toughness (Silva, 2007). A study by Haidekker, Andresen and Werner (1999) reveals that cortical shell evaluation of structural properties is more reliable method than cortical thickness measurement due to uncertainty in determination of a border between cortical and trabecular bone. The high correlation of cortical BMD and structural parameters that is observed with failure load indicates the importance of cortical shell contribution to vertebral stability.

Trabecular bone mechanical properties

Mechanical properties of Trabecular bone (modulus and strength) is explained by its microstructural parameters and is dependent on anatomical site and testing direction due to its anisotropic properties (Silva, 2007). Trabecular bone is about eight times more responsive to metabolic stimuli than cortical bone. This property make the trabecular bone a primary site for detecting early bone loss and osteoporotic therapeutic efficiency (Carballido-Gamio and Majumdar, 2006). Effective density (i.e. the weight of a cube of the bone divided by its total volume which is equal to bone volume fraction times the density of trabecular bone) elucidate 60% of trabecular bone strength and modulus variation. This parameter can provide up to 90% variance when combined with degree of anisotropy and principle orientation direction (i.e. the direction that bone is most likely loaded during physiological activities). The trabecular effective density significantly decreases with aging in both men and women. Microstructural basis for reduction in trabecular bone density is reduction in thickness and number of individual trabeculae that results in proportional decrease in trabecular strength. Other age related changes such as non-enzymatic cross links and microdamage may also lead to decline of trabecular strength. However, their importance remain to be proven (Silva, 2007).

1.2 Porcine spine

1.2.1 Functional anatomy of porcine spine

Porcine spine is divided into five anatomical regions similar to the human spine; the cervical, thoracic, lumbar, sacral and caudal. However, the curvatures and number of vertebrae in each region differ slightly (Figure 1.10). The pig has seven cervical vertebrae, fourteen to fifteen thoracic vertebrae and six to seven lumbar vertebrae. The cervical region is highly linear and the thoracic and lumbar regions have a continuous kyphotic curvature. The apex of the curvature is between the tenth thoracic vertebra and the thoracolumbar transition (Sack, 1982). As shown in Figure 1.11, the porcine thoracolumbar vertebrae are slightly different from human vertebrae. Having larger vertebral bodies in the craniocaudal and shallower in anteroposterior axis, a more slender profile is seen for porcine vertebra. Wider pedicles in the craniocaudal axis give a closed spinal canal in pigs as compared to human. The differences in anatomical dimensions of the porcine and human vertebrae have been quantified in several studies (Dath et al., 2007; McLain, Yerby and Moseley, 2002). For an equivalent vertebral level, the area of the endplates is about 30% smaller for pigs and vertebral bodies are about 40% larger in craniocaudal axis. The vertebral canal in the thoracolumbar transition is 50% narrower and 73% less deep in anteroposterior axis. Finally, the angle of mediolateral insertion of pedicle into the vertebral body is more prominent for pigs ($\approx 9^\circ$) than for human ($\approx 4^\circ$).

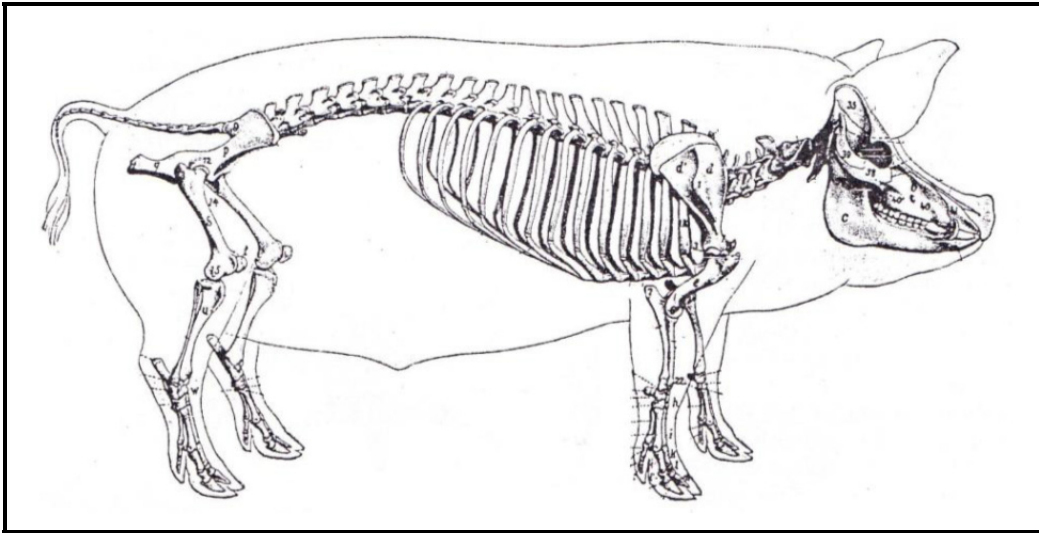

Figure 1.10 Schematic anatomy of porcine spine
(Adapted from Sack (1982))

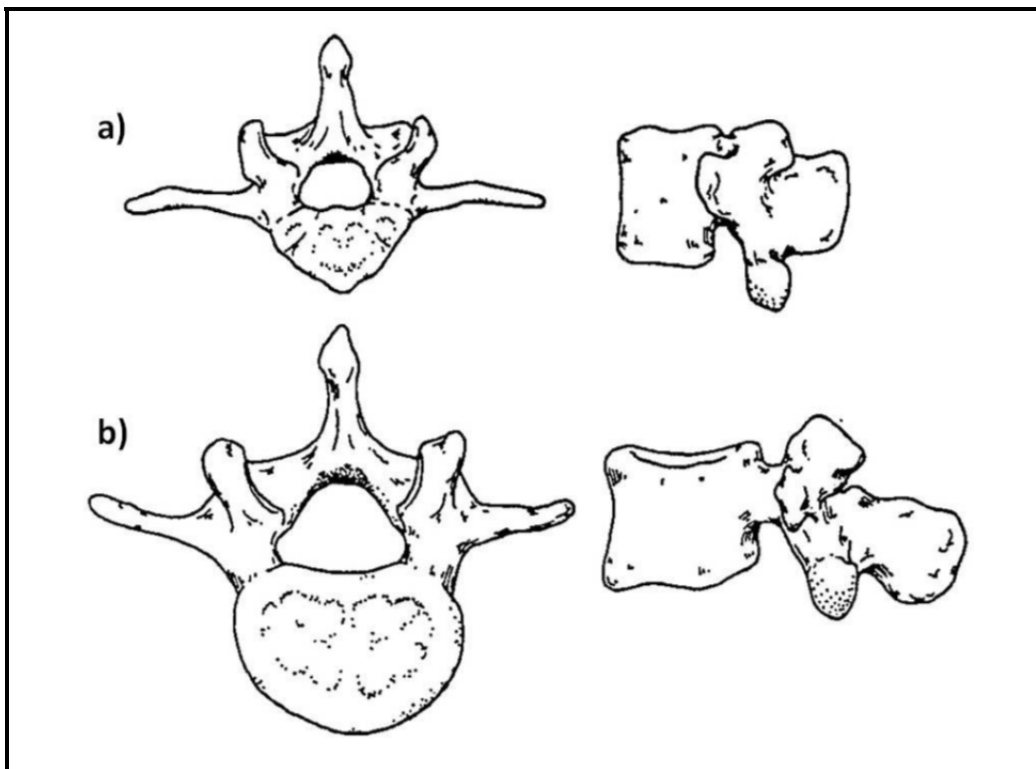

Figure 1.11 Axial and lateral profiles of a lumbar vertebra from (a)
pig and (b) human
(Adapted from McLain, Yerby and Moseley (2002))

1.2.2 Bone quality of porcine vertebrae

Porcine vertebral bone is much more dense than the human bone: porcine vertebrae have trabecular bone twice as dense ($\approx 0.37 \text{ g/cm}^3$) than human vertebral trabecular bone ($\approx 0.20 \text{ g/cm}^3$) (Aerssens et al., 1998). Higher density of porcine vertebrae can explain the twice larger compression strength than human vertebrae (Aerssens et al., 1998; Inuid et al., 2004). The bone density in posterior region of the vertebral body is slightly higher than the anterior region (Lin, Tsai and Chang, 1997).

1.2.3 Use of porcine specimens in spinal research

Research studies commonly use quadrupeds for biomechanical study on the spine. The porcine spine is regularly used as part of studies examining new spinal fixation methods, implant designs and the fixation strength. Below are some examples of biomechanical studies using porcine specimen.

- Tai et al. (2014) compared the performance of pedicle screws, hooks and the combination of the two in porcine spine. They concluded that pedicle screws provide the best fixation strength for spinal posterior instrumentation.
- Yazici et al. (2006) studied the biomechanical stability of pedicle screws inserted into expanded pedicles in immature pigs. They have found that pedicle expansion is a feasible solution to overcome the limitation of using pedicle screws in small vertebrae of pediatric patients. However, they have shown that the fixation strength can be significantly decreased by pedicle expansion using dilators.
- Cunningham et al. (2002) compared different surgical stabilization methods of lumbosacral fixation using porcine spines. They compared the range of motion and the failure effect from destructive testing when using pedicle screws, iliac screws, interbody cages and the combination of them.

- Abshire et al. (2001) characterized the fixation strength from conical and cylindrical pedicle screw designs in porcine vertebrae. They have concluded of improved fixation strength and stiffness for conical screws of specific size and thread design.

1.3 Synthetic bone surrogates

Human cadaveric vertebrae are often limited to elderly population and are difficult to obtain. Synthetic bone surrogates are good alternatives in biomechanical investigations. They reduce morphological variance and some of the confounding variables associated with cadaveric vertebrae, thereby, leading to better understanding of important factors affecting biomechanical properties of the bone. Technological developments and pre-clinical testing of implant fixation strength resulted in the development of numerous synthetic bone surrogates. An ideal bone surrogate should have the bone properties including structural and incorporated mechanical properties. It should also be cost-effective and available in the amount required.

McLain et al. (1997) used an analogue vertebral model consisting of: a rigid polyurethane foam body and pedicles simulating cancellous bone, and a thin layer of epoxy fiberglass simulating cortical bone. They aimed to evaluate the effects of different bone densities on pedicle screw bending strength. Au et al. (2011) used a similar synthetic vertebra for testing interbody device subsidence. Their surrogate simulated L5 vertebra geometrically. They have investigated the efficacy of their synthetic vertebra and compared it with human cadaveric vertebrae and polyurethane foam blocks using similar densities ($\approx 0.20 \text{ g/cm}^3$) for all specimens (Figure 1.12). Although their custom-made surrogate was a useful surrogate for parametric analysis, its stiffness and strength in the endplates were much higher than human vertebra. They suggested some modifications to their surrogate by thinning the endplate or reducing the amount of fiberglass in the SGFR epoxy.



Figure 1.12 Comparison of interbody device subsidence in: (a) Polyurethane foam block, (b) custom-made synthetic vertebra, (c) human vertebra
(Taken from Au et al. (2011))

Ito et al. (1993) have introduced a synthetic bone surrogate for assessing the influence of bone components in vertebrae (minerals, bone marrow and collagen) on BMD using QCT and MRI. Their surrogate contained composites of calcium carbonate (CaCO_3) to simulate bone minerals, cottonseed oil to simulate bone marrow, and agar to simulate collagen. Their results suggest that BMD is underestimated when using bone marrow substitute and overestimated with collagen substitute. Moreover, they reported that bone loss in vertebral trabecular bone is accompanied by an increase in bone marrow content which reveals osteoporotic changes histologically.

The current F1839-01 ASTM standard recommends polyurethane foam blocks as synthetic bone surrogates to allow for a consistent, repeatable comparison of different devices (American Society for Testing and Materials, 2007b). Patel, Shepherd and Hukins (2010) used polyurethane foam with different densities representing the normal (0.32 g/cm^3), osteopenic (0.16 g/cm^3), and osteoporotic (0.09 g/cm^3) cancellous bone to examine the effect of different screw thread designs and insertion angle on the fixation strength. Similar studies used the polyurethane foam blocks with specifications offered by ASTM to investigate the stability of different screw designs (Hsu et al., 2005; Kim, Choi and Rhyu, 2012; Krenn et al., 2008). Inceoğlu et al. (2006) used foam blocks to study the viscoelastic behaviour of bone when applying a cyclic axial pullout load. Another study by Hashemi, Bednar and Ziada (2009) determined the efficacy of pedicle screws augmentation by calcium phosphate in foam blocks of different densities.

1.4 Spinal fixation using pedicle screws

1.4.1 Prevalence and success

Use of pedicle screws as spinal internal fixation was introduced in the early 1970s. After the statements reported by American Spine Society in 1993 and 1996, clinical application of pedicle screws became to widespread acceptance by orthopedic surgeon. The pioneering, proceeding and evolution are described by review articles (Gaines Jr, 2000). Pedicle screw fixation is currently used as the standard surgical treatment for spinal fractures (Cheng et al., 2013; Sanderson et al., 1999; Vaccaro et al., 2003), deformities (Cheung, Lenke and Luk, 2010; Hasler, 2013), or degenerative changes (Boos and Webb, 1997; Resnick et al., 2005). Vertebral fracture can occur in traffic accidents, fall, or in osteoporotic individuals with low bone stock as the result of everyday activities such as forward flexion or lifting a light object (Myers and Wilson, 1997; Silva, 2007). Providing spinal fusion and stability, pedicle screw fixation is used in spinal fractures to prevent abnormal spinal curvature (e.g. kyphosis) or loss of height. Pedicle screws used for scoliotic curve correction in lumbar and thoracic spines have shown to help improving sagittal balance.

Several in vitro studies have indicated that pedicle screws provide higher pullout strength, shorter fusion segment allowing the maximum motion and higher stability through three column fixation in comparison to other internal fixation constructs such as sublaminar wires and hooks. Pedicle screws were reported to better control the vertebral rotation than hook constructs (Kim et al., 2004; Lenke et al., 2008; Suk et al., 1994). Wire and cable constructs require sublaminar dissection, although it is simple to apply, does not require intraoperative fluoroscopy and increase the torsional and lateral bending stability when used in conjunction with Harrington rods (Asher et al., 1988). Hooks, nevertheless, are recommended for use in small size pedicles to allow engagement by screws or in fractured pedicles. Margulies et al. (1997) have shown that hook-screw construct increased torsional spinal stiffness in synthetic vertebrae while there is no additional benefit in sagittal or coronal plane. Tai et al. (2014) compared different combinations of hook and screw in porcine spines and concluded to the

maximum fixation strength for pedicle screws. Comparing hooks, wires, and pedicle screws in spinal cadaver models, a study by Hitchon et al. have recommended significant increase in pullout strength for pedicle screws (Hitchon et al., 2003).

1.4.2 Pedicle screws

Pedicle screw types

Different pedicle screw types are available with different clinical utilities. Figure 1.13 illustrates polyaxial (PA) and monoaxial (MA) pedicle screws. Both types allow attachment to a longitudinal member (a plate or a rod).

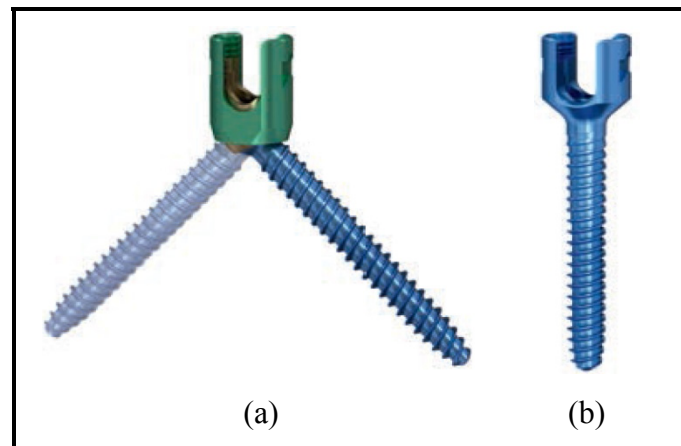

Figure 1.13 Pedicle screw types: (a) Polyaxial and (b) Monoaxial Pedicle Screw
(Adapted from DePuy Synthes (2013))

MA pedicle screws allow a higher corrective force to translate and derotate the vertebrae in spinal curve correction (Lenke et al., 2008). However, adjustments of screw and rod position relative to curved spine and rotated vertebrae are limited. Variation in pedicle screw placement in each vertebra may result in misalignment of all screw head slots (Figure 1.14). This would consequently cause undesirable intervertebral shear and axial force (Wang et al., 2011).

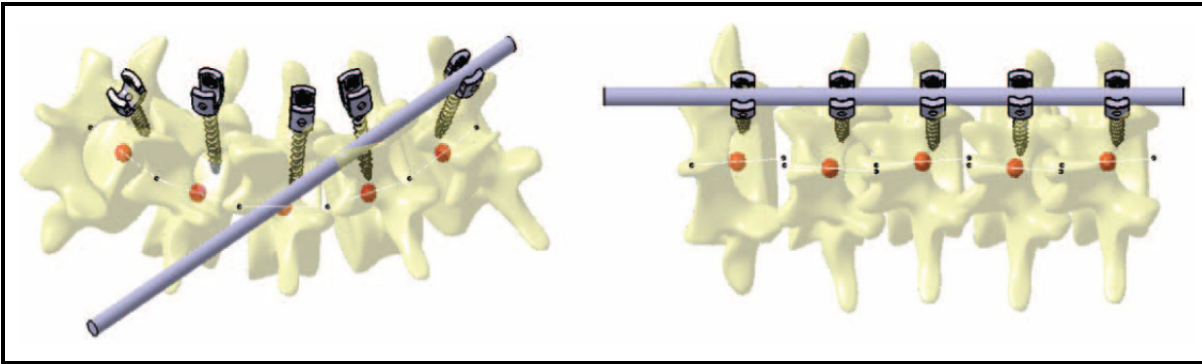

Figure 1.14 Difficulty in rod-screw alignment using MA pedicle screws in curve correction
(Taken from Wang et al. (2011))

The limitation of MA pedicle screws resulted in development of PA pedicle screws which have improved the positioning of screw in each vertebra relative to the rod. A pivoting post and a universal joint with a locking mechanism allow translation of instrumented vertebrae at any distance and angle to the rod (Figure 1.15). This mechanism provides a relative motion in three degree-of-freedom (DOF) and suggests more flexibility in attaining the final configuration of the spine (Wang et al., 2011).

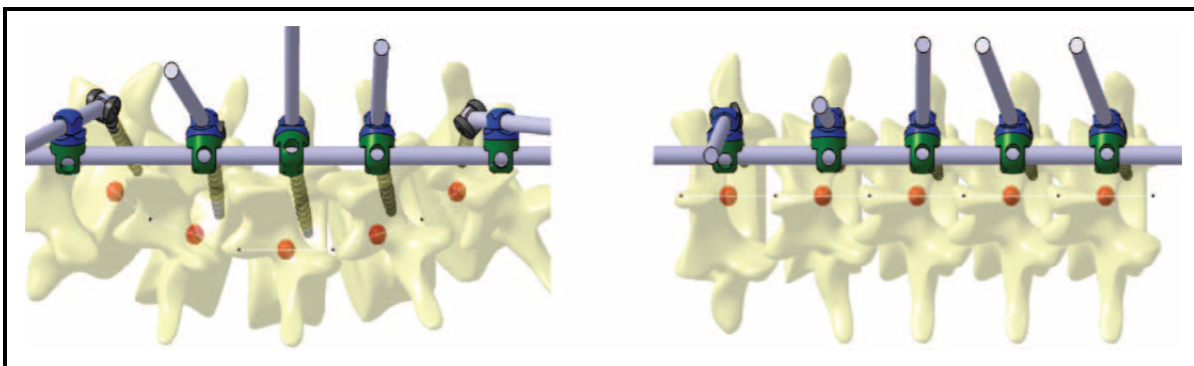

Figure 1.15 Improving configuration in curve correction using PA pedicle screws together with pivoting posts and universal joints
(Taken from Wang et al. (2011))

It should be noted that vertebrae experience a high corrective force in spinal deformity corrections which results in higher risks of damage at bone-screw interface, screw pullout or

vertebral fracture. Flexible PA pedicle screws allow a better control on correction forces and improve the failure risk management. They are consequently advantageous for osteoporotic patients with weak bone quality (Wang et al., 2011).

Pedicle screw material

Stainless steel and titanium screws are both manufactured and used. Titanium is a low density, hard metal showing a good biocompatibility and corrosion resistance. Medical grade titanium alloy is regularly used for rods, plates, and pedicle screws (Hirano et al., 1997). Titanium implants result in fewer artefacts than other metals (in particular stainless steel) in MRI and CT images (Ebraheim et al., 1994; Petersilge et al., 1996).

Pedicle Screw Size

The size of pedicle screw is selected based on vertebral level and pedicle geometry which can be determined using QCT scan. Typical pedicle screw sizes for the human thoracic spine range from 4 to 6 mm in diameter and 25 to 50 mm in length. The range for lumbar spine is 6 to 7.5 mm in diameter and 40 to 55 mm in length (Parker et al., 2011).

Pedicle screw design

The bone-screw interface plays a significant role in construct fixation strength. Therefore, altering the pedicle screw parameters shown in Figure 1.16 could significantly affect the fixation strength of the pedicle screw. The effective design factors include shaft design (conical or cylindrical (Aerssens et al., 1998; Hsu et al., 2005; Kim, Choi and Rhyu, 2012), cannulated (Inuid et al., 2004; Lin, Tsai and Chang, 1997; Tai et al., 2014), expandable (Cunningham et al., 2002; Yazici et al., 2006)), screw major diameter and core diameter (Chapman et al., 1996; Chatzistergos, Magnissalis and Kourkoulis, 2010; Inceoglu, Ferrara and McLain, 2004; Kim, Choi and Rhyu, 2012; Zhang, Tan and Chou, 2004), thread depth

and pitch (Kim, Choi and Rhyu, 2012; Krenn et al., 2008; Zhang, Tan and Chou, 2004), and the symmetrical or asymmetrical threads (Mehta et al., 2011).

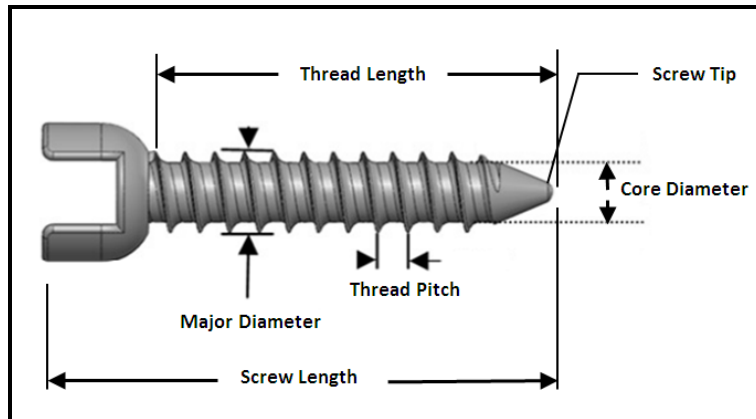

Figure 1.16 Overview of pedicle screw parameters

The cylindrical and conical types of screw designs, have significantly different purchase behaviour in-vitro (Inceoglu, Ferrara and McLain, 2004). A small increase in minor diameter of conical screw was observed to have a better screw-bone purchase compared to contralateral control within the same vertebra. This behaviour was justified by pedicle morphology which is slightly conical dorsally and thus, conical screws with large screw diameter in proximal pedicle can more successfully accommodate in pedicle. The enhanced screw-bone interaction in conical designed screw was confirmed biomechanically by greater torque, pullout force and stiffness in comparison to cylindrical screws.

The thread design alteration as asymmetric progressive trapezoidal form also has depicted greater insertional torque than traditional V-shaped threads in calf vertebrae (Inceoglu, Ferrara and McLain, 2004). Increased insertional torque is owing to special thread design in which the progressive narrowing flutes forming decreased pitch length compress a progressively smaller volume of trabecular bone as screw nears full insertion. Trapezoidal threads also increase the torque by creating greater fraction through inclined contact with cortical surface area and compress trabeculae toward cortex whereas the V-shaped threads cut and groove the trabecular bone. However, such benefit has not been observed for pullout

force and stiffness by the authors. These results describe that torque alone is not a good predictor of fixation strength particularly in non-standard screw and thread designs. These unexpected outcomes arise from anisotropic properties of the bone since orientation of trabecular bone yields different mechanical properties in different directions. In other words, frictional resistance between screw threads and bone lead to radial compression of trabeculae during insertional torque. Nevertheless, pullout is the result of trabecular failure in shear in axial direction. Mehta et al. (2011) have investigated the effect of different thread designs on pedicle screw fixation strength in osteoporotic cadaveric vertebrae (Figure 1.17). Thick and thin crest threads demonstrated a greater torque comparing to standard screw design. However, their pedicle screws with equal diameters presented similar pullout properties in BMD dependent manner. Their findings also support the clinical assumption that higher torque value lead to increased screw-bone interaction induced by friction between the threads and can predict pedicle screw fixation strength.

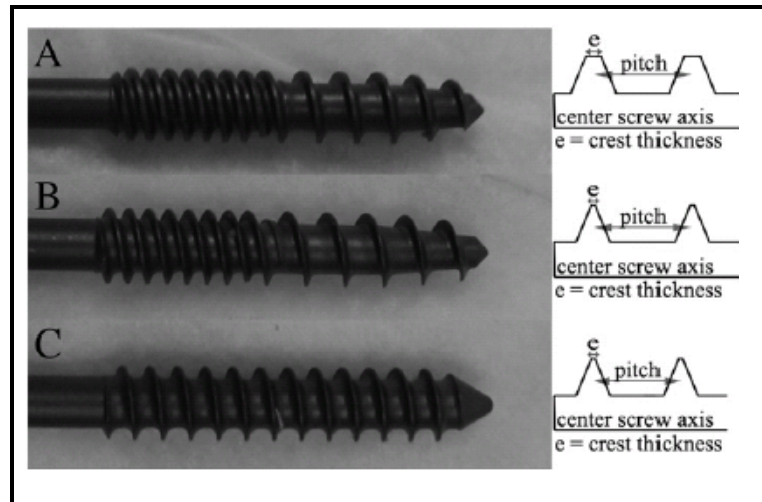

Figure 1.17 Pedicle screw thread designs:
 (A) thick crest, (B) thin crest and (C) standard
 (Taken from Mehta et al. (2011))

1.4.3 Pedicle screw fixation technique

Pedicle morphology determination

To obtain accurate pedicle screw placement with minimal risk to neural elements, determination of pedicle's shape and size is important. In particular, determining pedicle geometry is needed to select a screw with similar minor diameter at level of pedicle isthmus. This dimension is the most crucial in screw selection. Furthermore, inspection of pedicle geometry in all planes can confirm the coaxial orientation of pilot hole for screw insertion (Inceoglu, Ferrara and McLain, 2004).

Pedicle screw fixation procedure

Pedicle screw fixation is highly demanded. To improve the accuracy and safety during pedicle screw insertion, several assistive techniques have been developed. Roy-Camille, Saillant and Mazel (1986) who were pioneers in using pedicle screw introduced drilling the pedicle for screw insertion. However, the hazards with this technique led to application of a blunt probe for pedicle identification and screw insertion through image intensification. A standard procedure for safe insertion of pedicle screw is illustrated in Figure 1.18. This technique includes: (1) entry point localization (at the center of triangular bony confluence formed by the superior articular process, the transverse process and the pars interarticularis) and enlargement using an air drill or awl, (2) pilot hole creation through the pedicle isthmus into the vertebral body using a pedicle probe, (3) tapping the pilot hole and (4) screw insertion.

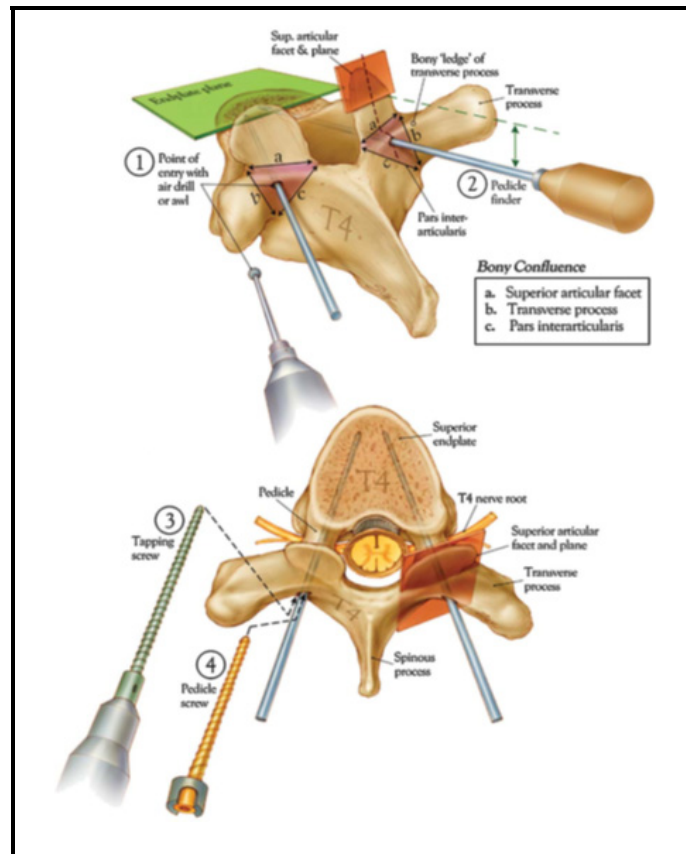

Figure 1.18 Pedicle screw insertion technique
(Adapted from Parker et al. (2011))

Pilot hole tapping versus untapping

Biomechanical studies have shown that the pedicle preparation can significantly affect the fixation strength. Chapman et al. (1996) have investigated the effect of tapping and untapping for different pedicle screw designs on polyurethane foam blocks of different densities. They indicated that tapping reduces the pullout strength. Carmouche et al. (2005) also showed a decreased fixation strength for tapping with same-size as the pedicle screw in human cadaveric vertebrae. However, they found the same effects for the holes undertapped by 1 mm and untapped holes. The latter was supported by other investigators (Mehta et al., 2011; Ronderos et al., 1997). Numbers of studies have stated that tapping is important only in osteoporotic spines (Halvorson et al., 1994; Wittenberg et al., 1993; Zdeblick et al., 1993).

Pedicle screw orientation

Two popular methods for pedicle screw insertion trajectory have been compared by Lehman Jr et al. (2003) for the best screw anchorage in thoracic spine (Figure 1.19). One method is *straight-forward* (SF) (screw trajectory parallel the superior endplate of vertebral body in sagittal plane) and the other is *anatomic* (AN) trajectory (angled 22 ° with respect to craniocaudal direction in sagittal plane and parallel to anatomic axis of pedicle). They have found that SF trajectory can increase the fixation strength particularly in osteoporotic spine since it would take the advantage of increased apparent density just inferior to the superior endplate of vertebral body. Furthermore, the entry point in SF trajectory on dorsal cortex appears to be denser than the entry point in AN trajectory.

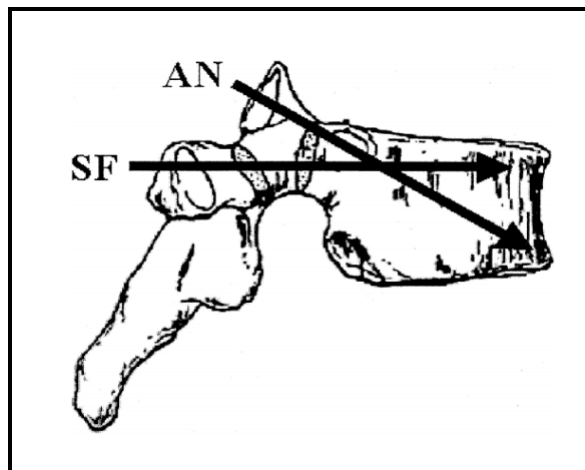

Figure 1.19 Pedicle screw trajectories:
(SF) straight-forward and (AN) anatomic
(Taken from Lehman Jr et al. (2003))

Barber et al. (1998) have compared the screw angles when inserted parallel to superior endplate of vertebral body (Figure 1.20). They concluded that converging screws would emphasize the screw fixation strength.

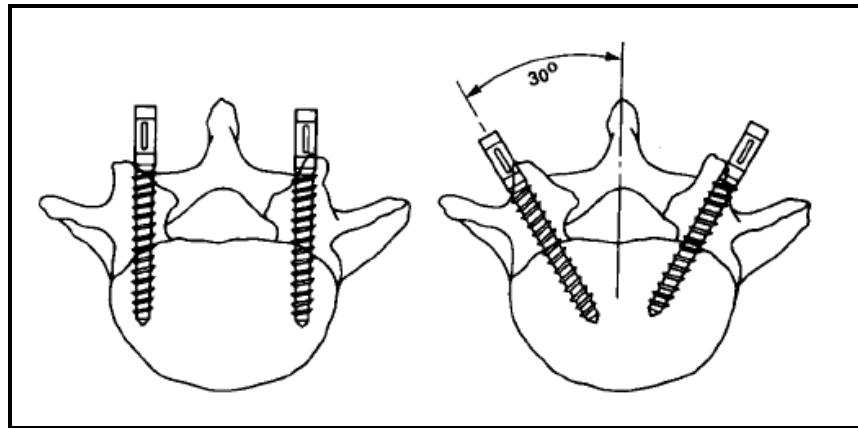

Figure 1.20 Pedicle screw insertion orientations:
 (left) straight and (right) convergent
 (Taken from Barber et al. (1998))

1.4.4 Supplemental techniques to pedicle screw fixation

Posterior fixation in osteoporotic spine encounters some constraints due to failure risk at weak bone-screw interface leading to screw pullout. There are surgical techniques that might strengthen the instrumentation purchase in osteoporotic bone. Multiple level and points of fixation can be one of the strategies by using segmental constructs, hooks, wires, and pedicle screws (Figure 1.21). Segmental fixation increases the number of fixation points and therefore, distributes the stresses on the bone (DeWald and Stanley, 2006).

In addition, novel screw designs (e.g. expandable screws) or screw hole augmentation by bone cements such as polymethylmethacrylate (PMMA) and calcium phosphate has been used to improve the fixation of pedicle screws in vertebrae. However, successful application of cement augmentation technique is encountered with limitations including: the occasional spread of the cement into the spinal canal, inability to perform revision surgery and possibility of further loosening with osteoporotic changes (Cheung, Lenke and Luk, 2010; Gaines Jr, 2000; Keen, 2007).

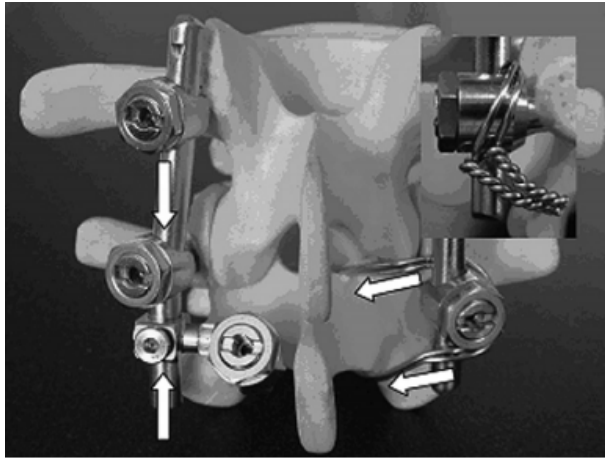

Figure 1.21 Strengthening the pedicle screw-fixation using: sublaminar hook (left) and sublaminar wires (right)
(Taken from DeWald and Stanley (2006))

Bicortical purchase, use of hydroxyapatite coated pedicle screws and double screws are other alternatives to improve fixation strength in osteoporotic spine (Ponnusamy et al., 2011). Although bicortical purchase with the anterior cortex of the vertebral body improves the screw anchorage, it encompasses a high risk of neurologic deficit particularly in thoracic spine (Lehman Jr et al., 2003; Zysset, 2009). The improvement in fixation strength can also be achieved by cross-linking the screws in an individual vertebra with a metal (Dick et al., 1997).

1.5 Biomechanical evaluation of pedicle screws fixation

1.5.1 Complications associated with pedicle screw fixation

Despite all the benefits described from the use of pedicle screw constructs for fixation of various spinal disorders, fixation failures are still reported. Most common complications are:

- Screw bending or breakage (Matsuzaki et al., 1990; McLain, Sparling and Benson, 1993);

- Screw pullout (Blumenthal and Gill, 1993; Katonis et al., 2003);
- Screw loosening and pullout (Dickman et al., 1992; Esses, Sachs and Dreyzin, 1993; Pihlajamäki, Myllynen and Böstman, 1997; Sanden et al., 2004);
- Pedicle fracture (Kothe, Panjabi and Liu, 1997).

Rates of failure are even higher in patients with osteoporosis. The osteoporotic weak bone stock at screw-bone interface can cause loosening of screw over time. The failure rate due to loosening is reported to be 0.8% to 17% (Dickman et al., 1992; Esses, Sachs and Dreyzin, 1993; Pihlajamäki, Myllynen and Böstman, 1997; Sanden et al., 2004). These problems urged the surgeon, researchers and engineers to evaluate the quality and strength of pedicle screw fixation through *in vitro* and *in vivo* tests. Finite-element analysis (FEA) can also be applied to analyze the stresses transferred to the bone by implants as well as the stress distribution at screw-bone interface and the fixation strength of new pedicle screw designs under various loading conditions (Hsu et al., 2005; Kim and Kim, 2010; Li et al., 2013).

1.5.2 Factors governing the fixation strength

Decreased fixation strength at screw-bone interface elucidates the importance of determining the factors affecting screw-bone interface particularly in osteoporotic spine. BMD measurement has been demonstrated as an indirect determinant of the pedicle screw fixation strength in many studies (Coe et al., 1990; Halvorson et al., 1994; Kumano et al., 1994; Zindrick et al., 1986). It was pointed out that the fixation strength of pedicle screws can be formulated from BMD data. Furthermore, the governing factors toward the screw-bone stability are described as pedicle morphology (Brantley et al., 1994; Krag et al., 1988; Zdeblick et al., 1993), screw insertion technique (Halvorson et al., 1994; Wittenberg et al., 1993; Zindrick et al., 1986), screw orientation (Barber et al., 1998; Carson et al., 1990; Ruland et al., 1991) and screw design (Inceoglu, Ferrara and McLain, 2004; Mc Lain Robert, Moseley and Sharkey, 1995; Mehta et al., 2011; Myers et al., 1996; Wittenberg et al., 1993; Zindrick et al., 1986).

1.5.3 Test methods to measure pedicle screw fixation strength

Pedicle screw constructs with increased stiffness and strength will result in quicker and more reliable spinal fusion (Bonnick, 2006; Kilbanski et al., 2001). The most common biomechanical tests to evaluate the performance of pedicle screws and stability of the fixation construct are the pullout test and insertional torque measurement. Research studies perform the aforementioned tests on either synthetic bone model or cadaveric vertebrae. The following sections will describe the measurement methods and governing factors of each test.

Pullout test

The importance of evaluating the performance of medical bone screws have resulted in the development of a standard pullout test method proposed by ASTM F543-07 (American Society for Testing and Materials, 2007a). This method is performed using a material testing machine and the following biomechanical properties are interpreted from the load-displacement curves (Figure 1.22):

- Pullout stiffness: the slope of most linear part (elastic region) of the curve before the yield point;
- Pullout yield: maximum load before plastic deformation;
- Pullout strength: maximum load at failure;
- Pullout energy-to-failure: area under the curve up to the failure.

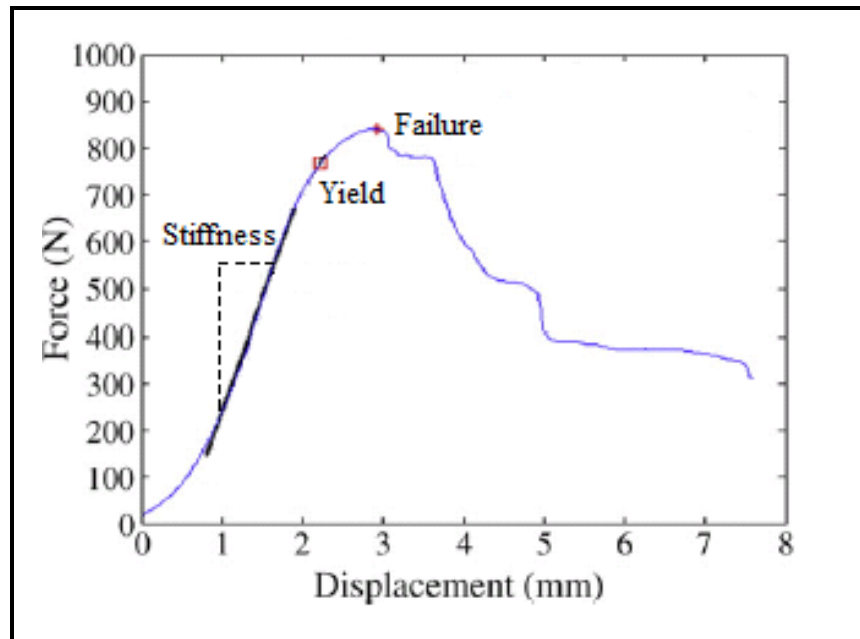

Figure 1.22 Typical force-displacement curve from a pullout test
(Adapted from Mehta et al. (2011))

Pullout together with other test modalities

Many studies have performed pullout test by applying an axial tensile load at a constant rate to determine the pedicle screw's pullout strength either on cadaveric vertebrae (Inceoglu, Ferrara and McLain, 2004; Kwok et al., 1996; Lehman Jr et al., 2003) or synthetic bone specimens (Hashemi, Bednar and Ziada, 2009; Kim, Choi and Rhyu, 2012). However, axial pullout does not seem to be the clinical mode of failure. Therefore several studies have tried to simulate the physiological loading condition to perform specific type of pedicle screw failure. A wide range of test methods has been reported for evaluation of pedicle screw fixation strength by different researchers. Some of the applied methods are described as follow.

Numerous authors believe that pedicle screw bending is a more clinically relevant mode of failure particularly in normal, healthy, dense bone while mode of failure in severe osteoporotic bone is due to screw loosening. This means that the loading mode that cause

screw failure is not only axial pullout but also the tangential traction load in coronal plane. McLain et al. (1997) have evaluated the factors affecting screw bending moment through applying a compressive load on superior endplate of synthetic specimens of various densities while the pedicle screw was fixed to a clamp. They have concluded that a change in cancellous modulus, which was thought to be a crucial factor, does not affect bending moment at initial fixation. Bending failure occurs if cancellous bone reaches the elastic threshold of the screw.

Similar studies (Inceoğlu et al., 2006; Zindrick et al., 1986) investigated the viscoelastic behaviour of bone-pedicle screw interface in animal and human cadaveric vertebrae. They have concluded that stress relaxation (time-dependent effect) at bone-screw interface affects mechanical performance during pullout test and significantly decreases the pullout strength and stiffness compared to continuous pullout at the same rate. This behaviour is speculated to be due to damage diffusion (damage already produced during screw insertion) and accumulation along the interface that cause loss of resistance to withdrawal. They suggested that stress relaxation pullout model may provide a better simulation of physiological condition in sitting or bending by introducing cyclic loading in time intervals and displacement increments. Therefore, a reason for screw micromotion and loosening can be assumed to be the result of repeated stress and relaxation in the long term. Overall, traditional pullout test may overestimate the ultimate pullout strength of screw implant.

Few studies considered a fatigue screw failure mode which is more common in osteoporotic bone and results to screw loosening (Johnston et al., 2006; Law, Tencer and Anderson, 1993; Lotz et al., 1997; Okuyama et al., 1993; Paik et al., 2012). When axial compressive load is transmitted to the screw through a rod or plate in normal physiological condition, a cyclic bending load is also applied to the screw in cephalocaudal direction (i.e. toggling). Therefore, a toggling test was performed through an initial non-destructive cyclic load on the screw head in the sagittal plane followed by a pullout load. However, there is no study available so far comparing the effect of toggling followed by pullout and axial pullout alone for conical

pedicle screws (designed for OP cancellous bone) neither in cadaveric nor in synthetic models.

Insertional torque measurement

Insertional torque is also a potential predictor of pullout strength and initial stability of the screw-bone fixation. Most studies have used a torque wrench to measure manually the torque during pedicle screw insertion. Although BMD is one of the main factors that can indirectly determine the pullout strength, measuring the local vertebral bone strength at the place of screw insertion may provide better estimation of screw stability. On one hand, the maximum torque measured during pedicle screw insertion has been demonstrated to be in direct relationship with the pullout strength and the BMD in several studies (Leite et al., 2008; Mehta et al., 2011; Myers et al., 1996; Soshi et al., 1991; Zdeblick et al., 1993). On the other hand, some other studies have denied such a relationship between insertional torque and pullout strength (Halvorson et al., 1994; Inceoglu, Ferrara and McLain, 2004; Okuyama et al., 2001; Sandén et al., 2010).

The effective factors on insertional torque are: pilot hole size, screw insertion technique, method of recording torque values (i.e. how much of screw is implanted when recording is made), screw design, BMD and pedicle diameter (Inceoglu, Ferrara and McLain, 2004; Lee, Park and Shin, 2012; Mehta et al., 2011; Myers et al., 1996; Sandén et al., 2010). However, to elucidate the controversy associated with the relationship between the insertional torque and pullout strength, more comprehensive studies should be performed. Other related factors during the procedure of pedicle screw placement (e.g. probe indentation during pilot hole creation) may also participate in the estimation of screw fixation strength.

Indirect measurement of bone quality during screw insertion

Knowledge of bone quality is helpful to distinguish the patient at risk for loss of pedicle screw fixation at screw-bone interface. Thereby, it would help surgeons with the decision of

applying the most appropriate fixation technique (Aerssens et al., 1998; Cheung, Lenke and Luk, 2010; Hashemi, Bednar and Ziada, 2009). Limited data is available in the literature regarding to bone quality measurement during screw insertion. Deckelmann et al. (2010) have used custom-made probes to measure the bone quality at the site of pedicle screw insertion using destructive tests of breakaway torque and indentation force measurement through the pilot hole created in the pedicle (Figure 1.23). After pedicle screw insertion, they performed a cyclic bending with load increments from 20 N up to 800 N to determine screw loosening (cut-out). They found a significant correlation between the breakaway torque and the failure load at cut-out. Similar relationship was observed between the indentation force and failure load at cut out. They found a significant correlation with regional BMD but no relationship was found with the failure load. Both breakaway torque and indentation force demonstrated a significant relationship with the regional BMD at the area of the screw tip.

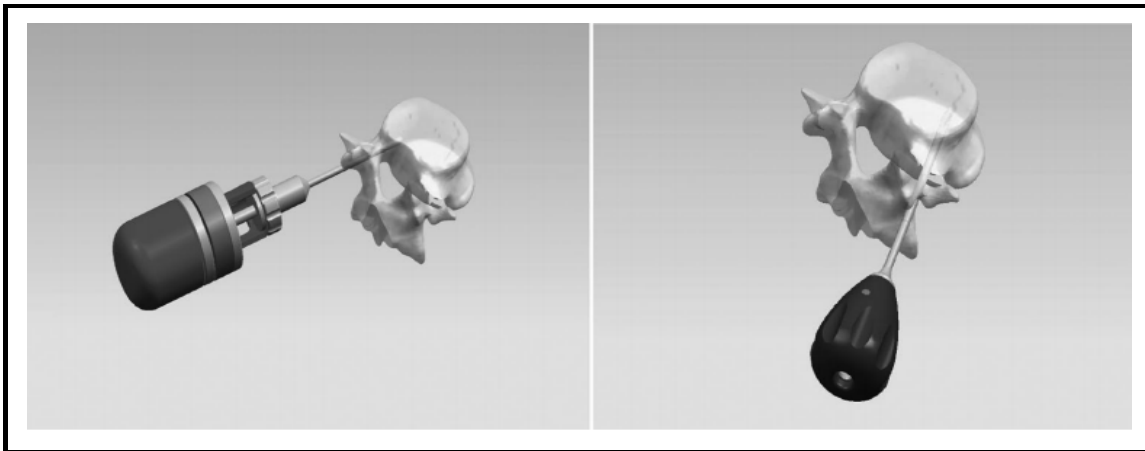

Figure 1.23 Indentation measurement tool (left), Torque measurement tool (right).
(Taken from Deckelmann et al. (2010))

Their custom-made probes have encountered some limitations. They require the use of additional instruments and extra operation time. Moreover, the breakaway torque measurement is dissimilar to insertional torque measurement while inserting the pedicle screw as the thread design would exert different loads to the cancellous bone. Also, the indentation probe does not simulate the pedicle probe used during pilot hole creation in the vertebra. Diez-Perez et al. (2010) have developed a micro-indenter tool for bone strength

measurement noninvasively in vivo. However, they measured the bone strength only in cortical bone of tibia and did not perform the micro-indentation on other bones. In addition, their measurement is based on microfractures creation. Though, this destructive measurement technique is not desired while performing pilot holes in vertebrae.

Summary of literature review

Pedicle screw fixation in various spinal disorders is beneficial in terms of facilitating the fusion, shortening instrumented segments, restoring the stability of the spine, improving spinal realignment and relieving pain. However, the complications associated with pedicle screw fixation include pedicle screw loosening, pullout, bending or breakage and pedicle fracture. Biomechanical investigations of pedicle screw fixation strength demonstrated that the factors contributing to the fixation strength are pedicle screw insertion technique, screw orientation, screw design, bone quality and pedicle morphology. Current test methods evaluating the pedicle screw fixation strength are insertional torque measurement and pullout test. Various modalities of pullout tests are reported as axial pullout, screw toggling prior to axial pullout and bending pullout. However, concerns related to each test method are subjects of controversy. Axial pullout is not likely the clinical mode of pedicle screw failure. Screw toggling is not well investigated in terms of comparison between different toggling modes and axial pullout. Therefore, it is concluded that there is a need to improve the understanding of pedicle screw loosening mechanisms. In addition, insertional torque measurement is not an evident predictor of pullout strength. The latter requires improvements on understanding the factors related to pedicle screw fixation strength. The test materials for evaluation of pedicle screw fixation strength are human cadaveric vertebrae, animal vertebrae and synthetic bone surrogates. The limitations with human cadavers encourage the investigators to use animal vertebrae to evaluate the pedicle screw fixation strength. Synthetic bone surrogates are mainly used to evaluate new devices or screw designs.

CHAPTER 2

HYPOTHESIS AND OBJECTIVES

The review of literature clearly demonstrates the need for evaluating pedicle screw fixation strength. On one hand, there is a controversy regarding to benefits of screw insertional torque measurement for the estimation of pedicle screw fixation strength. This could owe to a lack of standard experimental equipment and methods to measure the loads and torques during screw insertion as well as at pullout. The development of an experimental protocol measuring the indentation force while performing the pilot hole and the insertional torque during pedicle screw insertion would provide novel and valuable data on pedicle screw fixation strength.

On the other hand, this review also showed that the mechanism of screw loosening leading to fixation failure is not completely understood. Loss of integrity at screw-bone interface is inferred to be a major reason of screw failure and related subsequent complications. However, the current standard pullout test does not fully represent the physiological modes of screw failure. The craniocaudal cyclic bending loads on pedicle screws before pullout is assumed to simulate the screw loosening from daily activities such as normal walking. Repeated bending loads in other directions such as mediolateral may also contribute to screw loosening from vertebral derotation in spinal curve correction. The comparison of significant effects of multidirectional cyclic loadings on screw fixation stiffness and pullout force would provide reliable indications for in vitro evaluation method of pedicle screw fixation strength closer to the in vivo loading situation.

Exploring the aforementioned two research problems associated with the review of literature would improve the understanding on the pedicle screw fixation strength. This would eventually help spinal surgeons on decision of using the most appropriate fixation technique.

2.1. Hypotheses and specific objectives

The principal objective of this doctoral thesis is to improve the understanding on the mechanisms of pedicle screw loosening and the factors related to pedicle screw fixation strength. To achieve it, the following two hypotheses (H1 and H2) have been verified during this research project:

- H1 Measurement of indentation force while performing the pilot hole and the insertional torque during pedicle screw insertion are related to the pedicle screw pullout force and stiffness;
- H2 Cyclic bending load (toggling) of pedicle screw in craniocaudal (CC) and mediolateral (ML) modes affects the pedicle screw pullout force and stiffness.

The following three objectives (O1, O2 and O3) were proposed to verify the two hypotheses:

- O1 To develop and validate instruments for measuring the indentation force while performing the pilot hole and the insertional torque during screw insertion;
- O2 To compare the screw loosening mechanisms through toggling in different modes and evaluate their effects on pedicle screw pullout force and stiffness;
- O3 To establish the relationships between indentation force and insertional torque measurements and pullout force and stiffness with and without toggling.

CHAPTER 3

MATERIALS AND METHODS

3.1 Method overview

This chapter describes the methodology applied to verify the hypotheses and reach the objectives presented in chapter 2. Figure 3.1 illustrates how the defined hypotheses and objectives are articulated in relation to each other in three main steps. The first step is to develop and verify the instruments measuring the indentation force and insertional torque (H1 and O1). In parallel, the second step allows to improve the understanding of the mechanisms of pedicle screw loosening and their effects on fixation stiffness and pullout (H2 and O2). Finally in the third step, relationships between the measurements of indentation force and insertional torque and the screw pullout force with and without toggling are established (H1 and O3). The entire methodological process intends to improve the understanding of pedicle screw loosening mechanisms and the related factors to pedicle screw fixation strength.

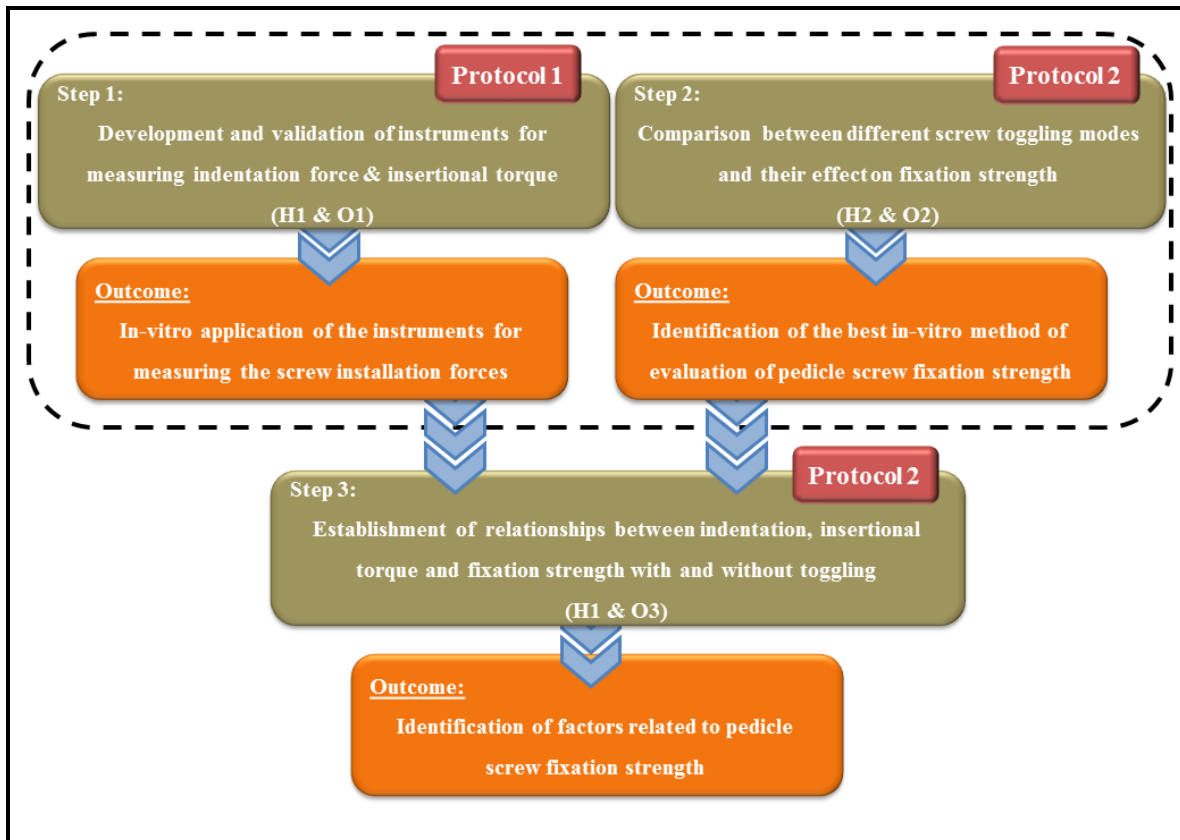

Figure 3.1 Methodological approach

3.2 Protocol 1: Experimental study on synthetic bone surrogates

To fulfill the objectives of this thesis, two experimental protocols have been developed. Protocol 1 was performed on synthetic bone models to validate the developed instruments for measuring the indentation force while performing the pilot hole and the insertional torque during screw insertion (H1 and O1). In addition, screw loosening and its effects on the fixation strength was also studied in this protocol to validate the instruments and methods which would have to be applied on porcine vertebrae in protocol 2. The result is a design of experiment with two loading conditions and three synthetic bone densities. With five repetitions, a total of 36 tests were performed. The protocol involves the following sequence:

description and preparation of specimens, description and preparation of experimental apparatus and biomechanical testing.

3.2.1 Synthetic bone surrogates preparation

This protocol was conducted on solid rigid polyurethane (PU) foam blocks ($5 \times 5 \times 4 \text{ cm}^3$; Sawbones, Pacific Research Laboratories Inc, Vashon, WA). PU blocks of three different density grades (one block from each density grade used for each loading condition) were used: grade 10 (0.16 g/cm^3), grade 20 (0.32 g/cm^3) and grade 30 (0.48 g/cm^3). Each PU block was embedded into an aluminum box which was wrapped with thin plastic film using polyester resin. The plastic wrap used to facilitate handling and the embedment was prepared to avoid movement of the specimen within the specimen box during different stages of biomechanical testing.

3.2.2 Experimental apparatus

Figure 3.2 shows a custom-made fixture designed by the author which was used for biomechanical testing in this research project. The fixture is composed of: 1) specimen box that holds the specimen embedded in polyester resin, 2) gimbal which provides rotation in flexion/extension and medial/lateral, and 3) translation table that allows horizontal displacement. A material testing system (858 Bionix II, MTS Systems Corporation, Eden Prairie, MN) was used to perform indentation, toggling and pullout tests. The fixture allows to align the specimen with the cross-head axis of the material testing machine to avoid undesired residual forces. Once the alignment was adjusted, all the joints were fixed to avoid further movements. To improve reproducibility, each specimen was secured in the same fixture throughout the experimental procedures for indentation, screw insertion, toggling and pullout tests. The indentation test was performed using a custom-made stainless steel indentation probe similar to surgical pedicle probe with 3 mm diameter and 35 mm effective insertion length (Figure 3.3).

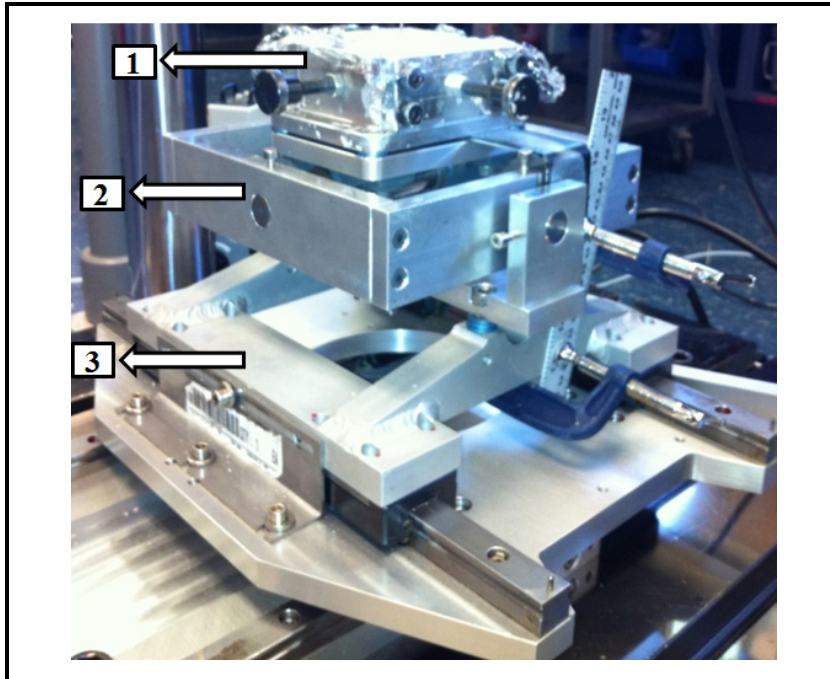

Figure 3.2 Custom-made fixture for biomechanical testing allows alignment of specimen with the cross-head axis of the material testing machine

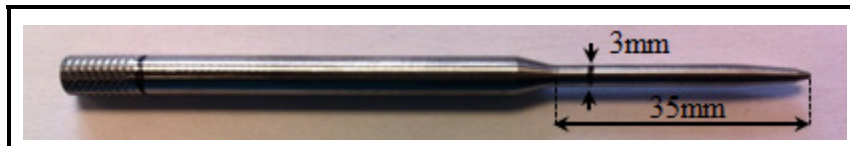

Figure 3.3 Custom-made indenter

A test bench was designed to insert the pedicle screw in a machine-controlled manner while measuring the insertional torque. As it is illustrated in Figure 3.4, the test bench is composed of a frame holding a rotating motor seated on a mobile plate free to axial displacement. The weight of the rotating motor and the plate were neutralized using custom metallic weights suspended from the test bench frame via two side pulleys. A screw driver provided by the manufacturer (DePuy Spine Inc., Raynham, MA) was secured under the rotating motor using

a pair of wedge slotted grips. Pedicle screw was coupled with the screw driver's tip. Polyaxial pedicle screws of 5 mm × 35 mm were used for all specimens.

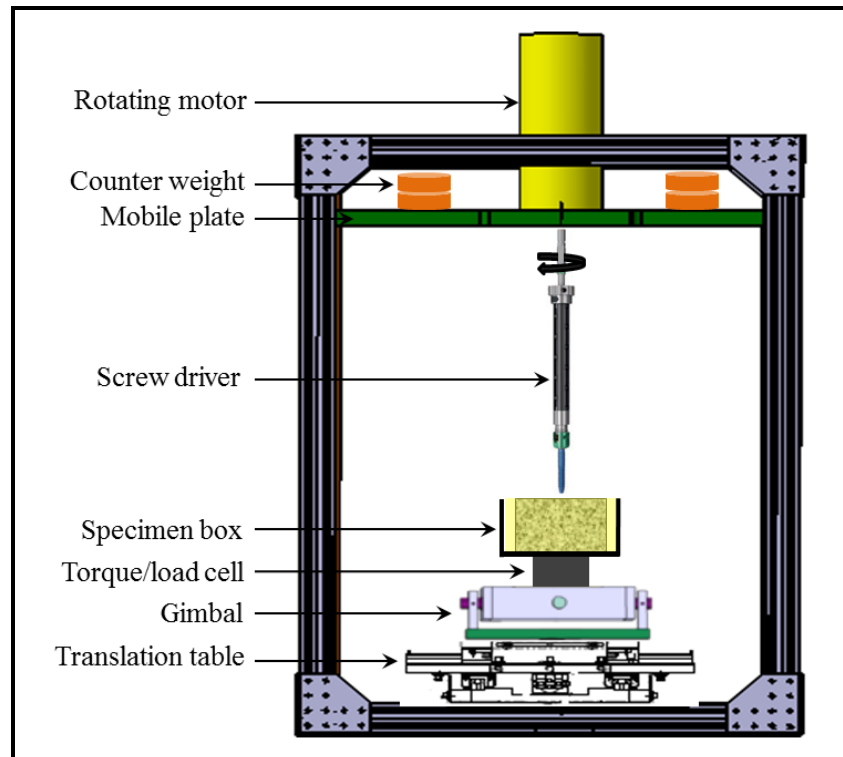

Figure 3.4 Custom-made test bench for pedicle screw insertion and insertional torque measurement

3.2.3 Mechanical testing

Table 3.1 presents the experimental sequence performed on synthetic bone specimens. Each sequential step is described in the following subsections.

Table 3.1 Sequential steps of biomechanical testing for protocol 1

Step	Process	Description
1	Indentation test	Installation of the test fixture on material testing system and application of indentation force to create the pilot hole into the specimen (section 3.2.3.1)
2	Insertional torque measurement	Installation of test fixture on custom designed test bench for screw insertion and application of motor-driven torque (section 3.2.3.2)
3	Toggling test	Installation of the test fixture on material testing system, repositioning the specimen box on the test fixture and application of toggling load on the screw head (section 3.2.3.3)
4	Pullout test	Reorientation of the specimen box on the test fixture followed by toggling test and application of pullout tensile load on the screw (section 3.2.3.4)
5	Data analysis	Calculation of maximum indentation force, insertional torque, toggling load, pullout force and stiffness using Matlab program and statistical analysis of the results using ANOVA, Wilcoxon test, regression analysis (section 3.2.3.5)

3.2.3.1 Indentation test

The test fixture was installed on material testing system (858 Bionix II, MTS Systems Corporation, Eden Prairie, MN) and the custom-made indentation probe was secured into the grips of the system's cross-head. The specimens were adjusted with the indenter such that the indenter was perpendicular to the specimen surface at the center (Figure 3.5). An indentation force was applied at a rate of 1 mm/sec to a depth of 25 mm similar to the study by Teoh and Chui (2008). Axial force and displacement data were recorded at a rate of 25 Hz using a linear variable displacement transducer (LVDT, MTS Systems Corporation, Eden Prairie,

MN) and a 2.5 kN load cell (662.20D-01, MTS Systems Corporation, Eden Prairie, MN) respectively.

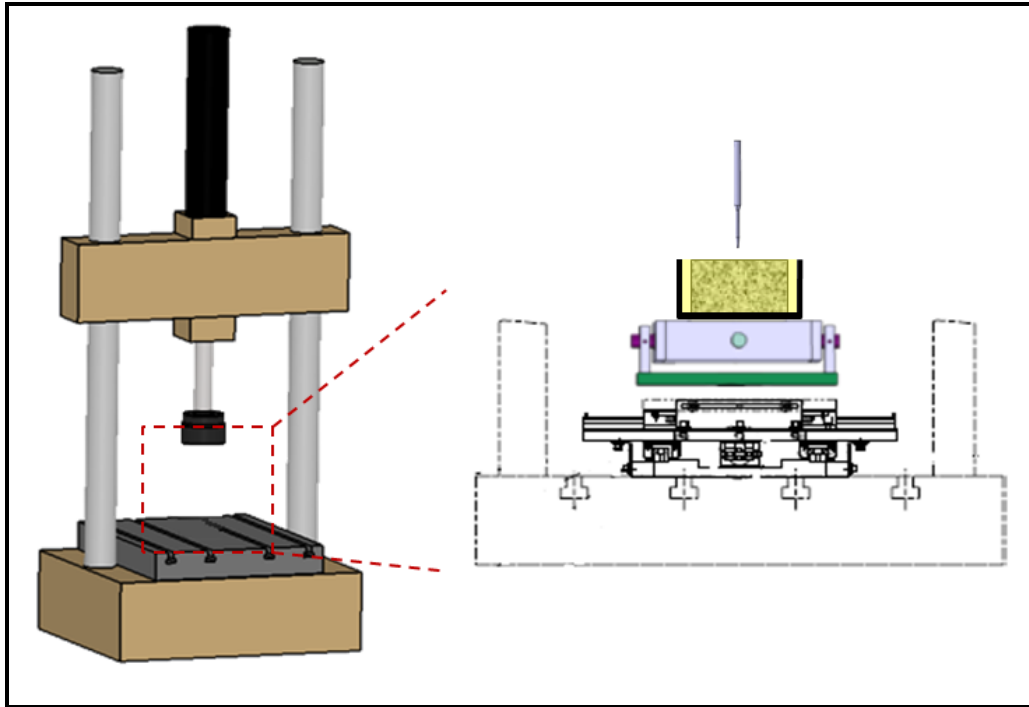

Figure 3.5 Experimental apparatus used for pilot hole creation into synthetic bone specimen

3.2.3.2 Insertional torque measurement

Once the pilot hole was created into the specimen through the indentation test, the test fixture was removed from material testing system and installed on the custom-made test bench for pedicle screw insertion. The specimen center hole was adjusted with the longitudinal axis of pedicle screw attached to the screw driver. A set of counterweights placed on the mobile plate allow exertion of an axial force for screw insertion (Figure 3.6). This force was set to 10 N based on preliminary tests. The screw insertion started at rotation speed of 3 r/min according to ASTM F543-07 (American Society for Testing and Materials, 2007a) until complete insertion of screw threads into the foam block. The torque was measured during screw insertion using a calibrated torque/load cell with maximum torque capacity of 5.7 Nm and axial load capacity of 444.8 N (1516 DMW-100, Bose Corporation, Eden Prairie, MN).

The insertion depth was monitored during screw insertion using an Optotrak optical camera with ± 0.3 mm precision (Northern Digital Inc., Ontario, Canada) to provide equal insertion depth for all specimens.

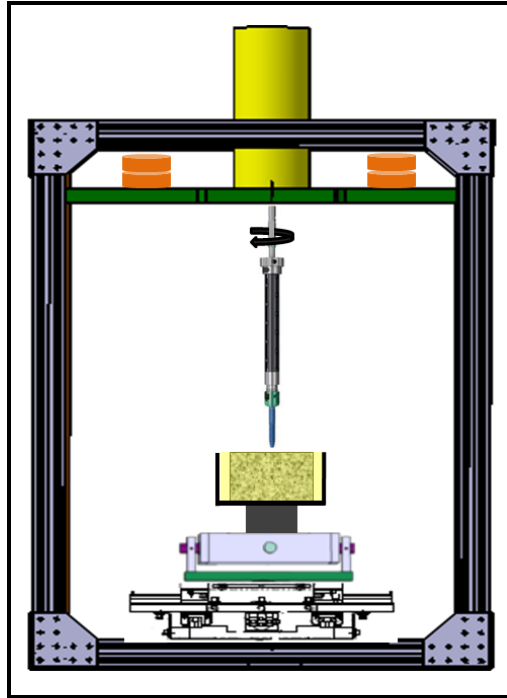

Figure 3.6 Pedicle screw insertion into synthetic bone specimen

3.2.3.3 Toggling test

Following indentation test and screw insertion, half of the specimens (one PU block from each density grade) were taken for toggling test, denoted as group I. The rest of specimens were kept for pullout test with no toggling, denoted as the control group II. Each specimen was mounted on the test fixture (Figure 3.7 (a)) and installed on the material testing system (858 Bionix II, MTS Systems Corporation, Eden Prairie, MN) to permit screw toggling. Pedicle screw's head was coupled with a rod and bolt provided by the screw manufacturer and gripped by the cross-head actuator. Toggling was applied through a rod coupled to the screw head perpendicular to the longitudinal axis of the screw with displacement of ± 1 mm

at 3 Hz frequency for 5000 cycles. Force and displacement data were recorded at a rate of 25 Hz using a linear variable displacement transducer (LVDT, MTS Systems Corporation, Eden Prairie, MN) and a 2.5 kN load cell (662.20D-01, MTS Systems Corporation, Eden Prairie, MN) respectively.

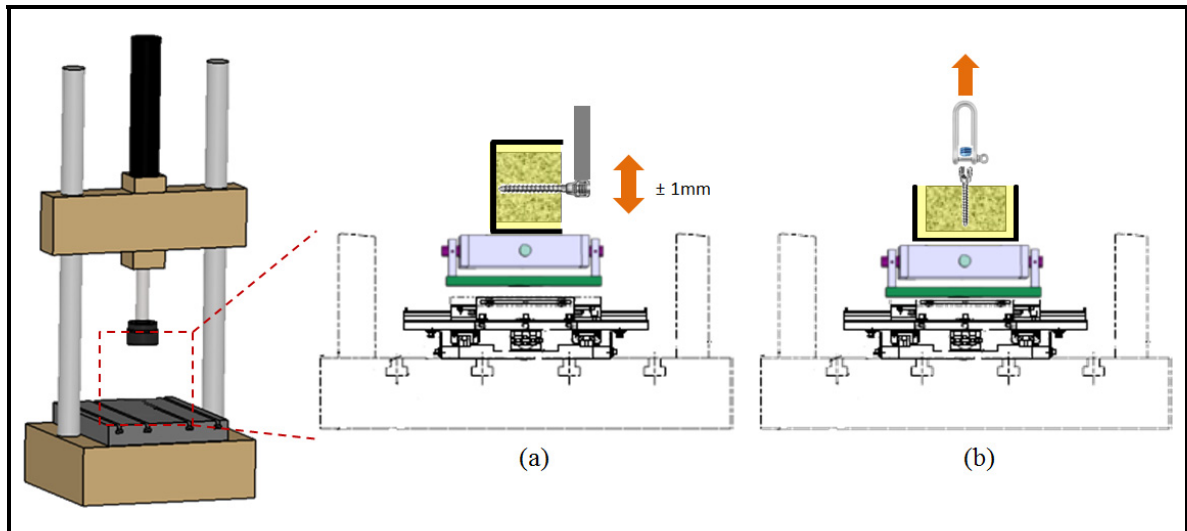

Figure 3.7 Material testing system, test fixture and load frame for (a) toggling test and (b) pullout test in synthetic bone specimens

3.2.3.4 Pullout test

All toggled and non-toggled specimens were taken for pullout test. The test fixture was already installed on the base of material testing system from the toggling test in previous step. Thus the specimen box was reoriented on the test fixture and adjustments were applied to align the screw longitudinal axis with the pullout direction. The screw head was linked to the system's actuator using a shackle and bolt (Figure 3.7 (b)). A tensile load was applied on the screw head at a rate of 5 mm/min according to the procedure described by ASTM F543-07 (American Society for Testing and Materials, 2007a) until the screw released from the foam block. Axial force and displacement data were recorded at a rate of 25 Hz using a 2.5 kN load cell (662.20D-01, MTS Systems Corporation, Eden Prairie, MN) and a linear

variable displacement transducer (LVDT, MTS Systems Corporation, Eden Prairie, MN) respectively.

3.2.3.5 Data analysis

All recorded data from indentation, insertional torque, toggling and pullout tests were processed in Matlab (Mathworks, MA, USA). The maximum indentation force during probe penetration into PU specimen was determined from the load-displacement curve. The peak torque and maximum toggling force were figured out. To characterize the pedicle screw fixation strength, two variables namely pullout force and stiffness were evaluated. The pullout force was defined as the maximum force during axial pullout of the screw and the stiffness was calculated as the slope of load-displacement curve before the yield.

The following techniques were used in this thesis for statistical analysis (Longnecker and Ott, 2001):

1. *ANOVA*: the analysis of variance (ANOVA) allows an examination of the main effects of independent variables and their interaction effects to determine their combined effects on the responses at 95% confidence interval (CI);
2. *Pareto analysis*: a Pareto chart compares the relative importance and statistical significance of the main and interaction effects between process parameters. This chart identifies influential factors in order of decreasing contribution;
3. *Wilcoxon test*: the nonparametric Wilcoxon statistic assumes that the data are not coming from normal distributions and compares the medians rather than the means of the two populations whether they are significantly different;
4. *Linear regression analysis*: to establish linear relationship between a scalar dependent variable and one or more independent variables, simple and multiple linear regression models are developed based on least square means.

The following statistical terms were also used:

1. *P-value*: the probability (ranging from zero to one) that the results observed in a study (or results more extreme) could have occurred by chance. If *P* is smaller than 0.05, the parameter is *significant* and if *P* is equal or greater than 0.05, the parameter is *insignificant*;
2. *Pearson's correlation coefficient (r)*: is defined as a measure of the strength and closeness (ranging from -1 to +1) of the linear relationship between two variables (Y, X). An *r* of +1 demonstrates a *perfect positive* correlation, an *r* of zero demonstrates *no correlation* and an *r* of -1 indicates a *perfect negative* correlation;
3. *Coefficient of determination (R²)*: provides a measure of variability in the observed response values and can be explained by the controllable factors and their interactions. If *R²* is greater than 75%, the predicted model is thought to be *sensitive* to variation of process variables. If not, the model is considered as *insignificant*.

In the context of this protocol, ANOVA was used to study the effects of screw toggling method, density and their interactions on pullout force and stiffness using Statgraphics Centurion XVI (Statpoint Technologies, Inc., Warrenton, VA). Wilcoxon test was implemented to explore potential differences between toggling modes for pullout force and stiffness. Pearson's correlation coefficients were calculated to determine the relationship and significance of indentation force and insertional torque with pullout force and stiffness individually.

3.3 Protocol 2: Experimental study on porcine vertebrae

The second protocol was conducted on porcine vertebrae to investigate the effects of different toggling modes on fixation stiffness and pullout (H2 and O2). In addition, it was intended to establish relationships between indentation force and insertional torque and the screw pullout force with and without toggling (H1 and O3). A full factorial design of experiment with two factors: vertebral level and toggling mode, each at three levels was

performed on porcine vertebrae. With five repetitions, a total of 54 tests were completed. The protocol involves the following sequence: description and preparation of specimens, description and preparation of experimental apparatus and biomechanical testing.

3.3.1 Specimens preparation

Twenty seven vertebrae (54 pedicles) were harvested from the lumbar segment (L1 to L3) of nine mature pigs (average 24 weeks old). The bones surrounded by muscles and intervertebral discs were fresh frozen for a minimum of degradation due to freeze-thaw cycle (Van Ee, Chasse and Myers, 2000). They were defrosted twelve hours before biomechanical testing. Specimens were imaged using a CT scanner (GE Medical System, Milwaukee, WI) to eliminate the presence of fracture or pathologic bone. For each vertebra, the apparent density of trabecular bone (BMD) of the vertebral body and pedicles was calculated according to the method described in previous studies (Boisclair et al., 2011; Hobatho, Young Rho and Ashman, 1997; Levasseur, Ploeg and Petit, 2012). Anatomical dimensions of individual pedicles including pedicle width (Ped.W), height (Ped.H) and area (Ped.A) (Figure 3.8) were measured from two-dimensional views of CT scans. Each vertebra was then isolated and cleaned from surrounding soft tissues and the intervertebral discs. To provide a rigid fixation for biomechanical testing, the vertebral body of each specimen was embedded into an aluminum frame using polyester resin up to the pedicles and posterior processes to be instrumented afterwards. The specimens were preserved hydrated during biomechanical testing using distilled water spray.

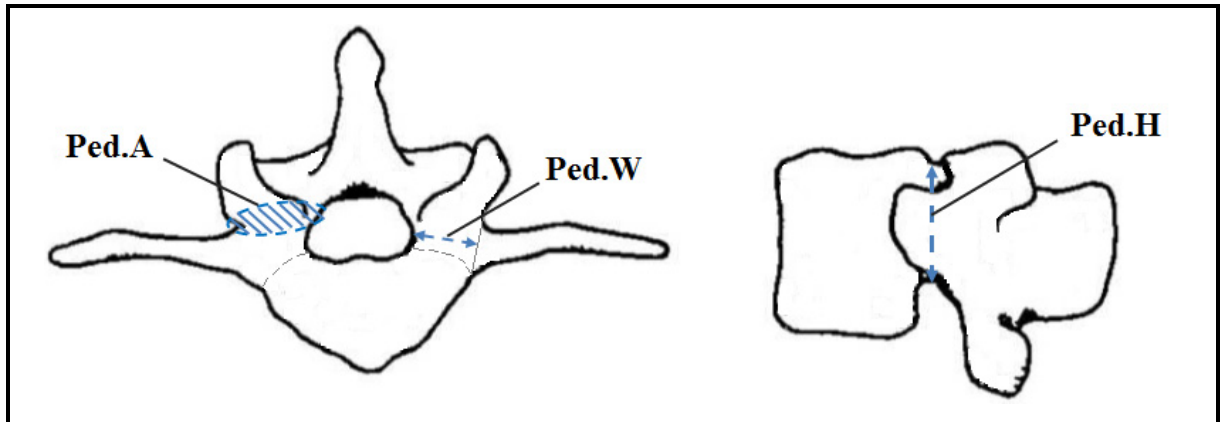

Figure 3.8 Anatomical dimensions measured for individual pedicles of each porcine vertebra

3.3.2 Experimental apparatus

The test fixture shown in Figure 3.2 was also used for this experimental protocol. Similar to protocol 1, biomechanical tests including indentation, toggling, and pullout were performed using a material testing system (858 Bionix II, MTS Systems Corporation, Eden Prairie, MN) and the screw insertion procedure was done using the custom bench test. The same pedicle screws size and length as for protocol 1 were used to evaluate the effects of other factors since screw size and design has been shown to affect the fixation strength. The screw size used in this thesis was selected from preliminary tests based on the size and shape of the specimens. Direct anatomic measurements of outer and inner pedicle width were performed using a mechanical caliper (an accuracy of 0.1mm) and on CT images respectively to ensure that the screw fits into the pedicles. The custom-made indentation probe (Figure 3.3) and test bench (Figure 3.4) used in protocol 1 were also employed for indentation and screw insertion respectively.

3.3.3 Biomechanical testing

Table 3.2 describes the experimental sequence of protocol 2. Each step is described in the following subsections. In this protocol, it was assumed that there is no difference in terms of mechanical properties between left and right pedicles of one vertebra.

Table 3.2 Sequential steps of protocol 2

Step	Process	Description
1	Indentation test	Cavity creation into the pedicles of each individual vertebra using custom probe through the material testing system (section 3.3.3.1)
2	Insertional torque measurement	Pedicle screw insertion into the pedicles using custom-made test bench and insertional torque measurement (section 3.3.3.2)
3	Toggling test	Evaluation of the screw loosening mechanism through three toggling modes: CC, ML, and NT (section 3.3.3.3)
4	Pullout test	Pedicle screw fixation strength assessment by axial pullout following the toggling test (section 3.3.3.4)
5	Data analysis	Calculation of maximum indentation force, insertional torque, toggling load, pullout force and stiffness using Matlab program and statistical analysis of the results using ANOVA, Wilcoxon test, regression analysis (section 3.3.3.5)

3.3.3.1 Indentation test

The entry point was on the superior articular process and the hole trajectory was set to an angle of 30 ° with respect to posterior-anterior direction in transverse plane and parallel to superior endplate of the vertebral body (Figure 3.9).

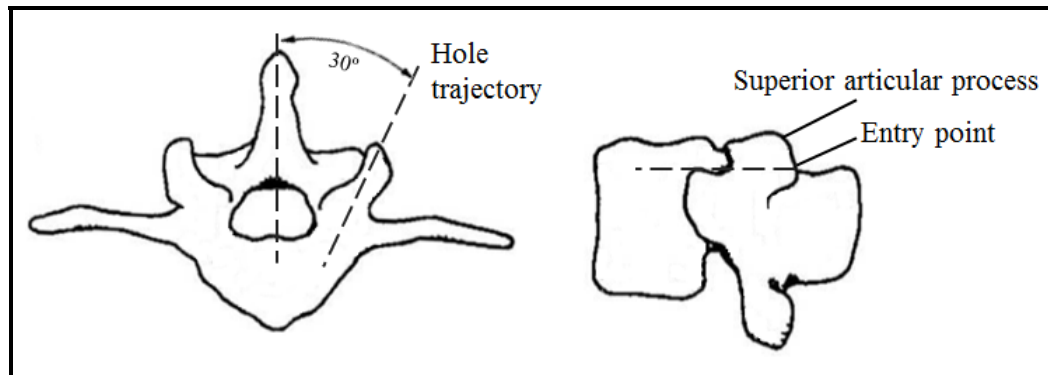

Figure 3.9 Entry point and hole trajectory for individual pedicles

A small area of the cortical bone was removed using a surgical rongeur to ensure only the indentation force into the trabecular bone is measured. Similar to the method described for the protocol on synthetic bone specimens, the test fixture was installed on the material testing system (858 Bionix II, MTS Systems Corporation, Eden Prairie, MN). Each specimen's pedicle was adjusted with the custom indentation probe (Figure 3.10) to provide the convergence cavity creation demonstrated by Barber et al. (1998). The indentation force was conducted at 1 mm/sec to a depth of 30 mm. The insertion depth was set to be the same as pedicle screw's effective length. Axial force and displacement data were recorded at a rate of 25 Hz using a 2.5 kN load cell (662.20D-01, MTS Systems Corporation, Eden Prairie, MN) and a linear variable displacement transducer (LVDT, MTS Systems Corporation, Eden Prairie, MN) respectively.

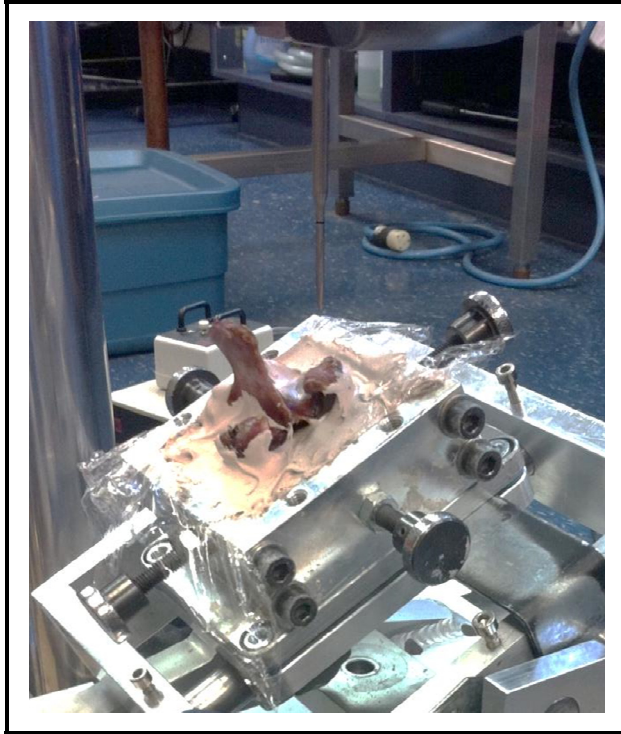

Figure 3.10 Test fixture allowing lateral rotation of specimen box to align the indenter with pilot hole trajectory in the pedicle

3.3.3.2 Insertional torque measurement

Following indentation, the specimen and the test fixture were placed on the custom-made test bench for screw insertion. The pedicle hole was aligned with the pedicle screw which was vertically held by the screw driver. Counterweights (1 kg each) were located on the mobile plate to provide an axial force of 22 N (verified from preliminary tests) during screw insertion (Figure 3.11). The screw was inserted at a rate of 3 r/min. The torque was measured during screw insertion using a calibrated torque/load cell with maximum torque capacity of 5.7 Nm and axial load capacity of 444.8 N (1516 DMW-100, Bose Corporation, Eden Prairie, MN). The insertion depth was monitored during screw insertion using an Optotrak optical camera with ± 0.3 mm precision (Northern Digital Inc., Ontario, Canada) to provide equal insertion depth of 30 mm for all specimens.

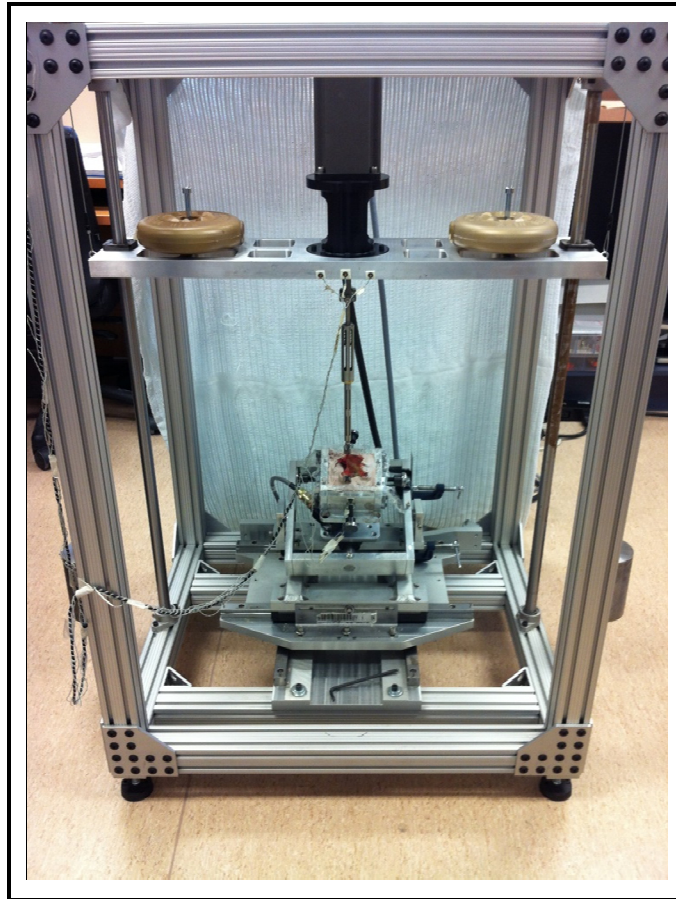

Figure 3.11 Custom-made test bench for screw insertion in porcine vertebra

3.3.3.3 Toggling test

Instrumented pedicles of each vertebra were assigned for three toggling modes: craniocaudal toggling (CC), mediolateral toggling (ML) or no toggling (NT). The assignment of toggling mode was randomized within the eighteen pedicles to ensure an equal distribution of each toggling mode across all vertebral levels. It was assumed that there is no difference in mechanical properties between left and right pedicles. Toggling test was conducted on the screw through the material testing system (858 Bionix II, MTS Systems Corporation, Eden Prairie, MN) using custom fixtures (Figure 3.12). The screw heads were coupled with a rod and bolt provided by the screw manufacturer. For the CC tests, the cyclic bending load was

applied in the sagittal plane through the rod perpendicular to the screw's longitudinal axis (craniocaudal direction) with a maximum displacement of ± 1 mm at a frequency of 3 Hz for 5000 cycles. For ML toggling, the cyclic load was conducted on the coupled rod in mediolateral direction of the transverse plane with the same procedure as described for CC toggling. Force and displacement data were recorded at a rate of 25 Hz using a linear variable displacement transducer (LVDT, MTS Systems Corporation, Eden Prairie, MN) and a 2.5 kN load cell (662.20D-01, MTS Systems Corporation, Eden Prairie, MN) respectively.

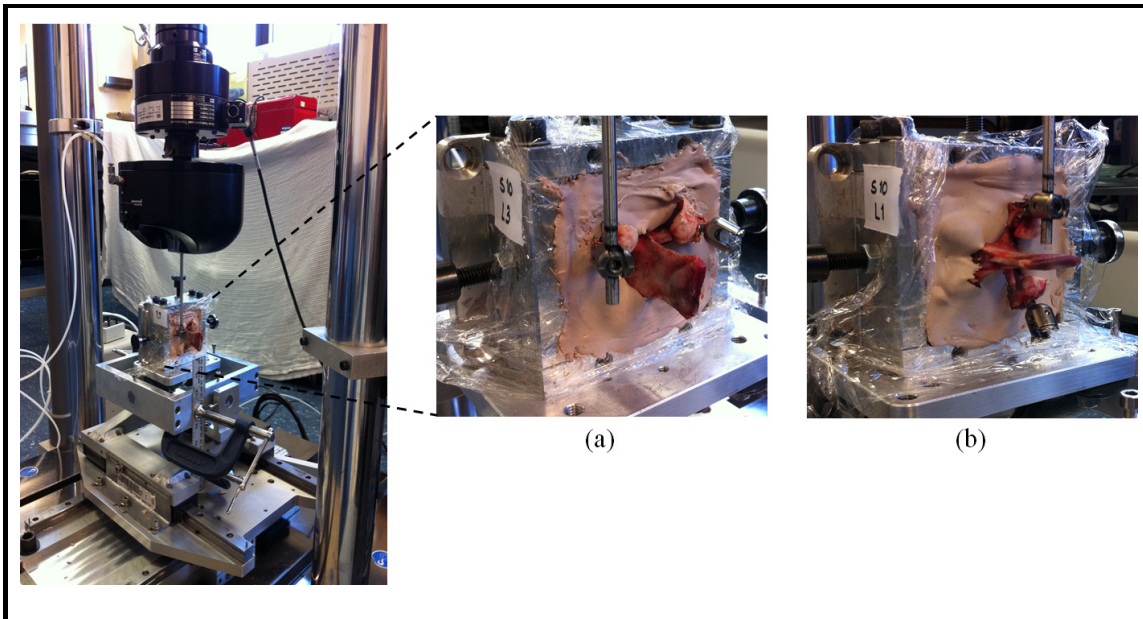

Figure 3.12 Material testing system and test fixture configurations for (a) CC and (b) ML toggling

3.3.3.4 Pullout test

Upon completion of the toggling, each toggled or not-toggled specimen was reoriented in a custom fixture allowing coaxial alignment of pedicle screw with the material testing system (858 Bionix II, MTS Systems Corporation, Eden Prairie, MN) cross-head axis for axial pullout (Figure 3.13). A tensile load was applied akin to the procedure described for synthetic specimen at constant rate of 5 mm/min until complete pullout of the screw released from the

vertebra. Axial force and displacement data were recorded at a rate of 25 Hz using a linear variable displacement transducer (LVDT, MTS Systems Corporation, Eden Prairie, MN) and a 2.5 kN load cell (662.20D-01, MTS Systems Corporation, Eden Prairie, MN) respectively.

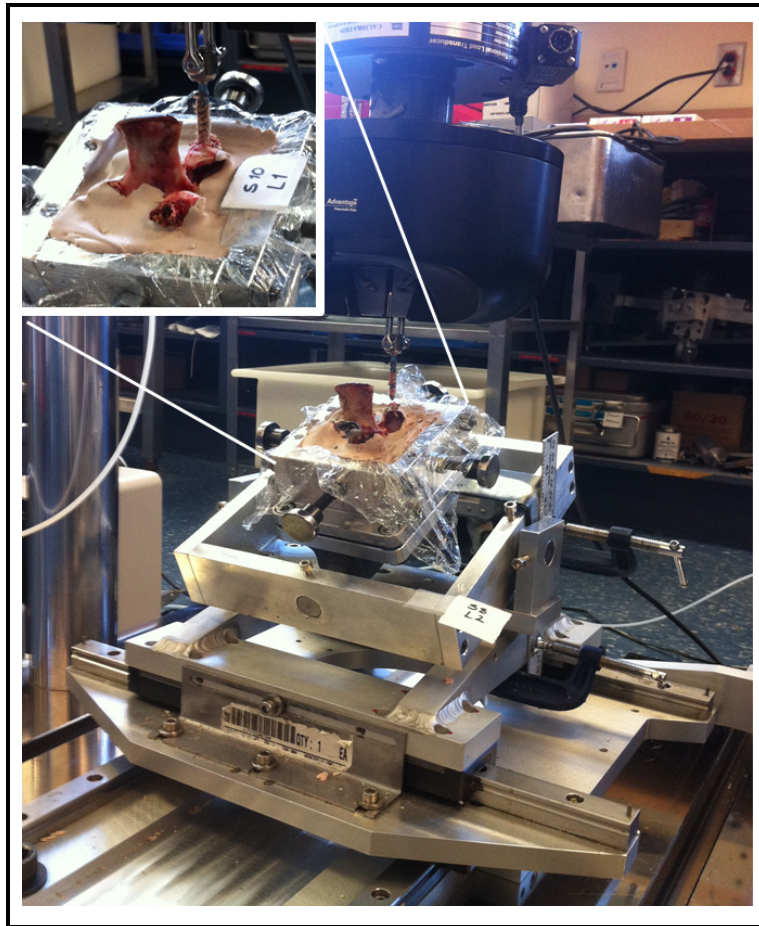

Figure 3.13 Test fixture and configuration of the pullout test on porcine specimens

3.3.3.5 Data analysis

Experimental data were processed using Matlab (Mathworks, MA, USA). The peak force from load-penetration curve of indentation test was determined. Maximum torque values and maximum toggling forces were figured out. Pullout force and stiffness values were computed from the load-displacement curves to describe the pedicle screw's fixation strength. Pullout

force was defined as the maximum force that the bone-screw interface can resist before failure (plastic deformation or negative deflection on the curve) and the stiffness was defined as the slope of the most linear part of the curve (elastic region) before the yield point.

Wilcoxon tests were used to investigate potential difference between the vertebral levels in different measurements (indentation force, insertional torque, BMD, Ped.W, Ped.H, Ped.A, pullout force and stiffness). In addition, ANOVA analyses were also performed to describe the effects of toggling (applying cyclic bending to the screw in various modes: CC, ML and NT) and of vertebral levels on pullout force and stiffness. Potential difference between toggling modes for pullout force and stiffness were explored using Wilcoxon test. Relationships and significance of each measurement (indentation force, insertional torque, BMD and pedicle anatomical dimensions) with pullout force and stiffness were determined using Pearson's correlation coefficients. Finally, forward stepwise multiple regression analyses were performed to establish potential improvement in the relationships between pedicle screw pullout force and stiffness with combinations of measurements (indentation force, insertional torque, BMD and pedicle anatomical dimensions). A level of significance of 0.05 was set for all statistical tests.

CHAPTER 4

RESULTS

This chapter presents the results of the two protocols described in chapter 3. The results are presented in two sections: the first for protocol 1 performed on synthetic bone surrogates and the second for protocol 2 performed on porcine vertebral specimens.

4.1 Experimental study on synthetic bone surrogates

This section presents the validation results from developed instruments for pilot hole indentation and screw insertion. In addition, the effect of toggling is demonstrated on various bone densities. The statistical analyses are used to highlight the effects of toggling and change of density on pedicle screw fixation strength (pullout force and stiffness). Furthermore, relationships between the maximum indentation force during hole creation, the maximum torque during screw insertion and the fixation strength (pullout force and stiffness) are investigated.

4.1.1 Indentation force, screw insertional torque, pullout force and stiffness with and without toggling

Figure 4.1 illustrates typical curves of indentation force as a function of indentation depth for the three different PU foam blocks densities. The maximum indentation force was measured at the maximum probe indentation depth in all curves and was recorded for further analysis. Typical graphs of screw insertional torque as a function of insertion depth for various PU foam densities are presented in Figure 4.2, the maximum torque was measured at the final position of the screw within the foam blocks in full insertion. Regardless of density, similar trends were observed in the graphs of indentation force-insertion depth and insertional torque-insertion depth in all repeated tests.

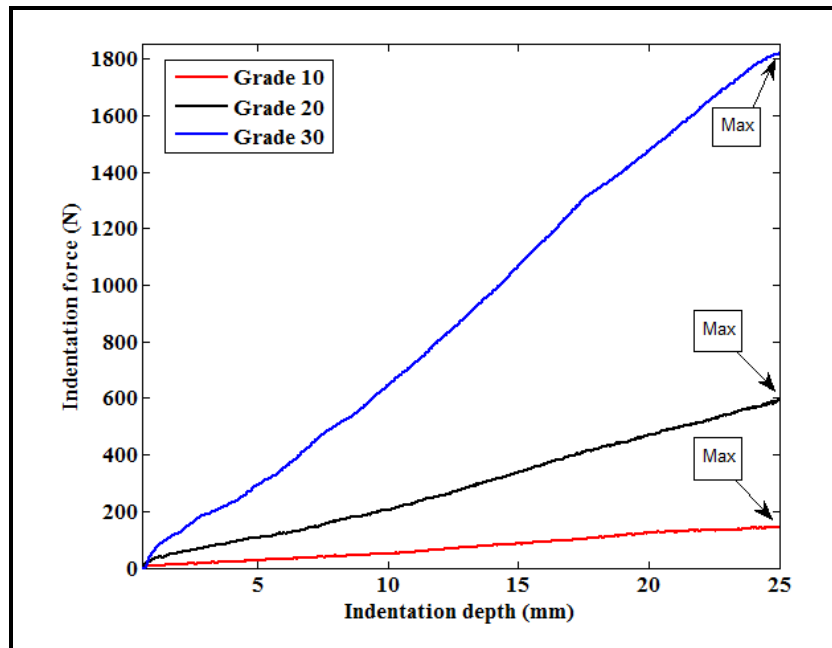

Figure 4.1 Typical curves of indentation force as a function of indentation depth for the three different densities

Table 4.1 presents the mean values and standard deviations (SD) of the maximum indentation forces and maximum insertional torques obtained from 12 tests for each density. The highest indentation force and insertional torque values were observed for grade 30. Small SD for all densities demonstrate the repeatability of pilot hole indentation and screw insertional torque measurement. Wilcoxon tests showed that the indentation force and insertional torque are significantly affected by the foam density as all values were significantly different ($P < 0.0001$) between each other.

Table 4.1 Mean \pm SD of indentation force and insertional torque for the three densities

Response	Indentation force (kN)	Insertional torque (Nm)
Grade 10	0.16 \pm 0.02	0.75 \pm 0.10
Grade 20	0.79 \pm 0.03	2.67 \pm 0.12
Grade 30	1.85 \pm 0.09	5.69 \pm 0.19

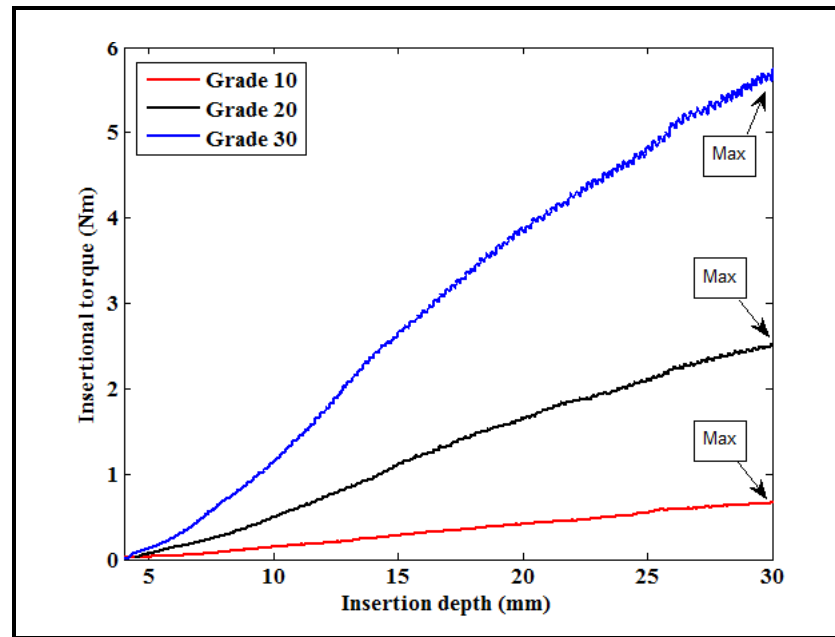

Figure 4.2 Typical curves of insertional torque as a function of screw insertion depth at the three different densities

Figure 4.3 demonstrates typical pullout force versus displacement curves for toggled and non-toggled screws. Regardless of density, the same curve shapes were observed for each toggling mode in all repeated tests. Two responses were extracted from the force-displacement curves. The pullout force was recorded as the maximum load at failure and the stiffness was calculated from the slope of the linear part of the curve before the yield point.

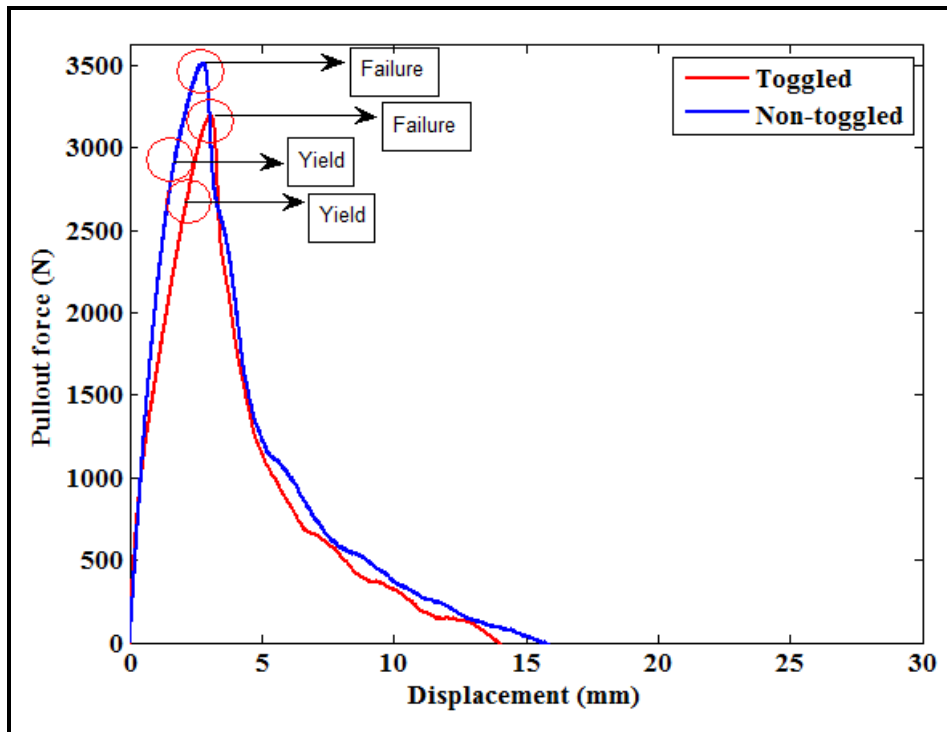

Figure 4.3 Typical curves of pullout force as a function of displacement for toggled and non-toggled screws

Mean and SD of the pullout force and stiffness with and without toggling were calculated from six tests for each density and toggling mode (Table 4.2). Small SD for all the measurements in current study demonstrates a high repeatability for all densities. According to Table 4.2, the results of current study for non-toggled pullout force are in the range reported in the literature. However, since none of the previous studies have performed screw toggling on bone surrogates, no comparison can be made for pullout force of toggled screws.

Table 4.2 Mean \pm SD of toggled and non-toggled pullout force and stiffness for PU foam blocks of various densities from different studies, Asterisk (*) denotes range of values obtained for various screw designs

Dependent variables	Toggling mode	Author (year)	Grade 10	Grade 20	Grade 30
Pullout force (kN)	Toggled	Current study	0.29 ± 0.07	1.28 ± 0.02	3.09 ± 0.28
	Non-toggled	Current study	0.27 ± 0.11	1.51 ± 0.06	3.21 ± 0.12
		Kim, Choi and Rhyu (2012)	-	$1.38 \pm 0.18 - 2.28 \pm 0.09^*$	-
		Patel, Shepherd and Hukins (2010)	$0.12 \pm 0.03 - 0.38 \pm 0.03^*$	$1.11 \pm 0.05 - 1.15 \pm 0.06^*$	-
		Chao et al. (2008)	-	$1.47 \pm 0.07 - 1.50 \pm 0.07^*$	-
Stiffness (kN/mm)	Toggled	Current study	0.60 ± 0.007	1.01 ± 0.09	1.65 ± 0.03
	Non-toggled	Current study	1.06 ± 0.02	1.23 ± 0.02	1.98 ± 0.06

4.1.2 Effects of toggling mode and density on pullout force and stiffness

The Pareto charts in Figure 4.4 illustrate the relative importance and statistical significance of the density and toggling mode on the screw pullout force and stiffness. It is observed that pedicle screw pullout force and stiffness are significantly affected by PU foam density (A) and toggling mode (B). Moreover, higher values of density lead to increased pullout force and stiffness. According to Figure 4.4, the change in the pullout force as well as the stiffness is non-linear in density dependent manner (AA). The interaction effect between density and toggling mode (AB) is insignificant on variation of responses (pullout force and stiffness). Table 4.3 demonstrates the *P*-values of all effects on the pullout force and stiffness.

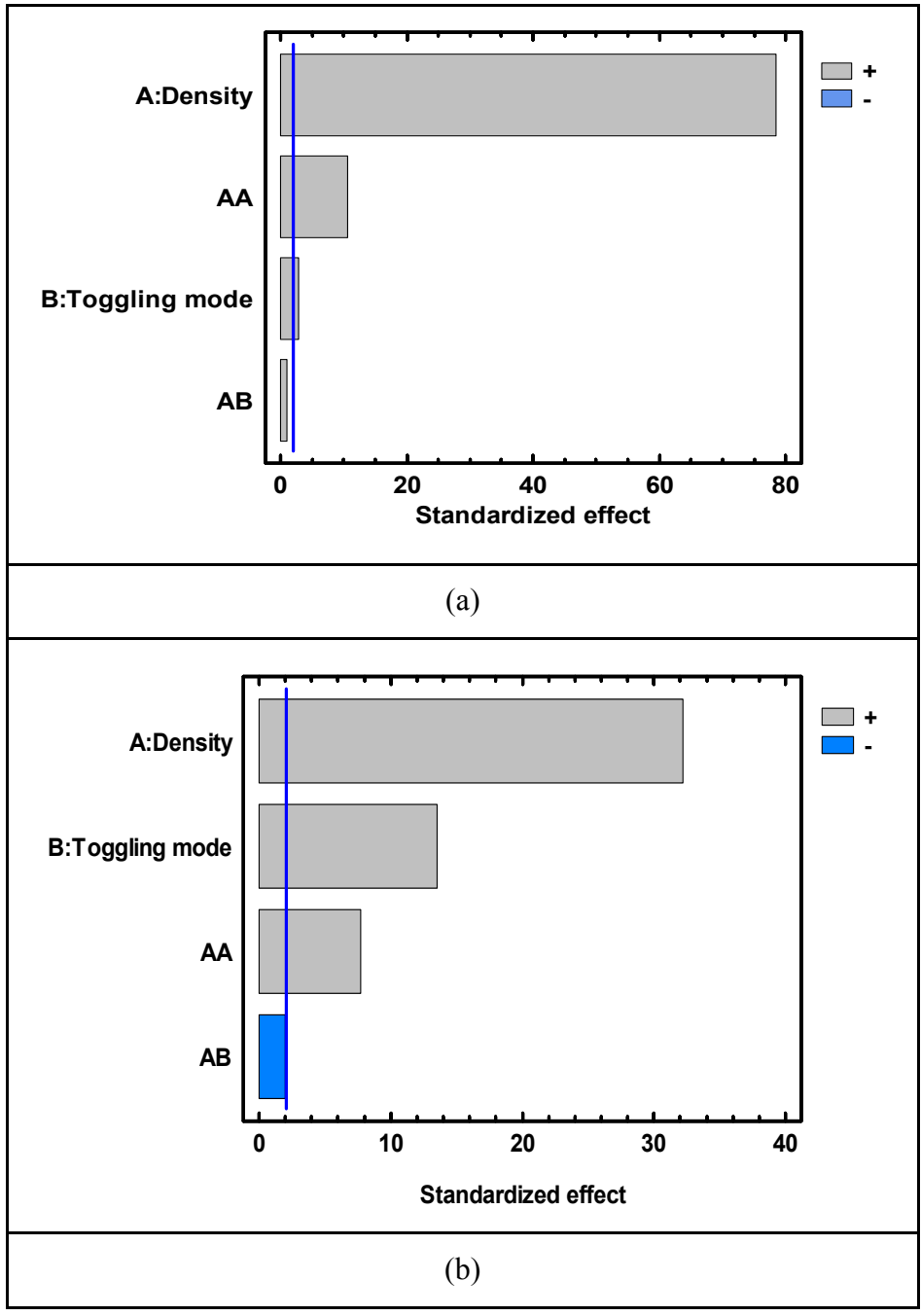

Figure 4.4 Pareto charts for the significance of the effect of toggling mode and density on: (a) pullout force, (b) stiffness

Table 4.3 Significance of the effect of density and toggling mode on the pullout force and stiffness, asterisk (*) denotes as significant effect

Dependent variables	Independent variables	<i>P</i> -value
Pullout Force	A: Density	<0.0001*
	B: Toggling mode	0.01*
	AB	0.3462
	AA	<0.0001*
Stiffness	A: Density	<0.0001*
	B: Toggling mode	<0.0001*
	AB	0.062
	AA	<0.0001*

The 3D response surface models of pullout force and stiffness are depicted in Figure 4.5. The highest pullout force and stiffness are observed with grade 30 with non-toggled screws whereas the lowest pullout force and stiffness are shown with grade 10 with toggled screws. Change of density from a lower grade to a higher grade yields in a non-linear change of pullout force and stiffness.

Figure 4.6 illustrates the comparisons between toggling modes for pullout force and stiffness of various PU foam densities. As for the pullout force, significant difference was only observed between toggled and non-toggled screws with grade 20 foam blocks ($P = 0.01$). Though, as for the stiffness, significant differences were observed between toggled and non-toggled screws with all densities: grade 10 ($P = 0.03$), grade 20 ($P = 0.03$) and grade 30 ($P = 0.03$). According to Figures 4.4-4.6, it is understood that although toggling has a significant effect on the pullout force, the variable with the most significant effect is density. As for the stiffness, the contribution of toggling is more important with respect to effect of density.

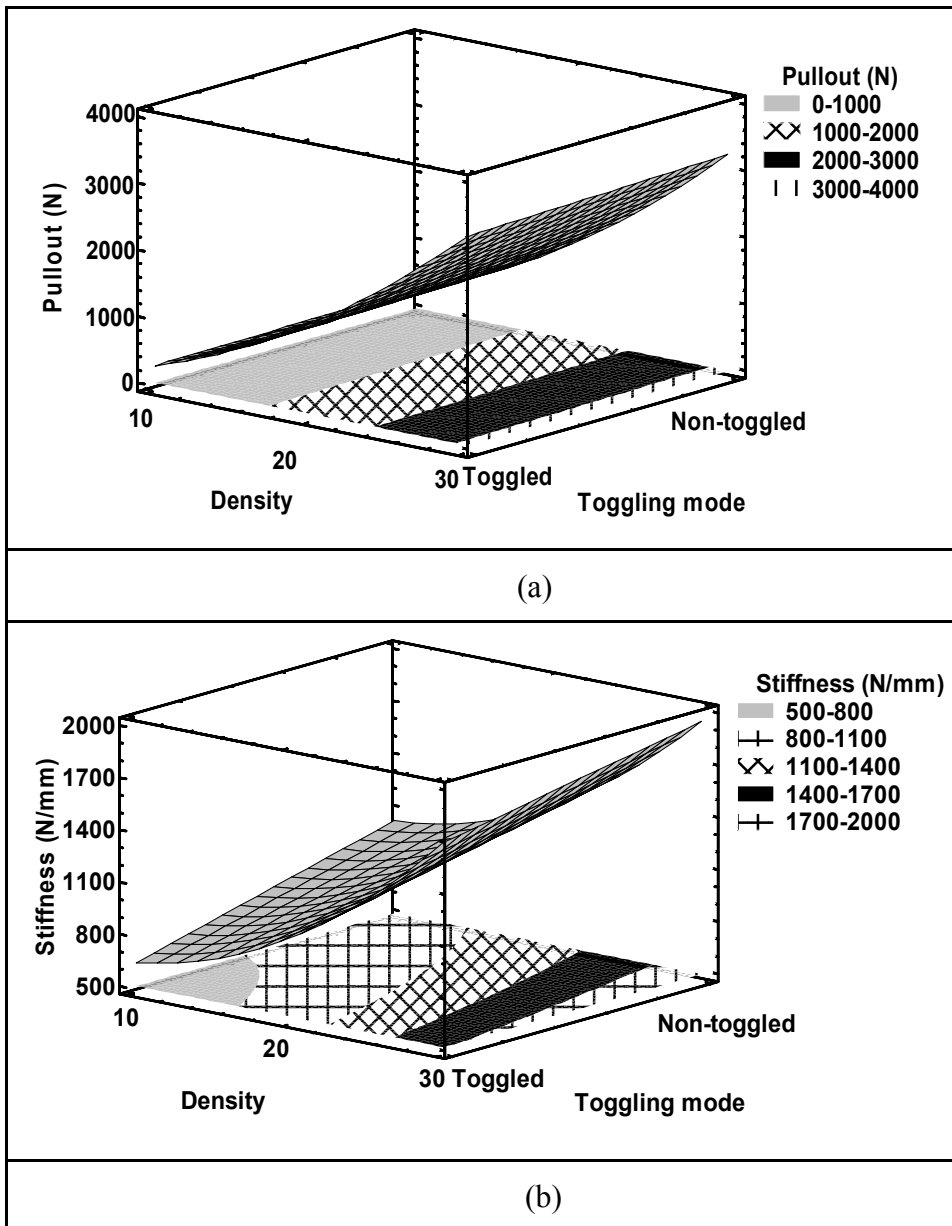

Figure 4.5 3D response surface plot of: (a) pullout force, (b) stiffness

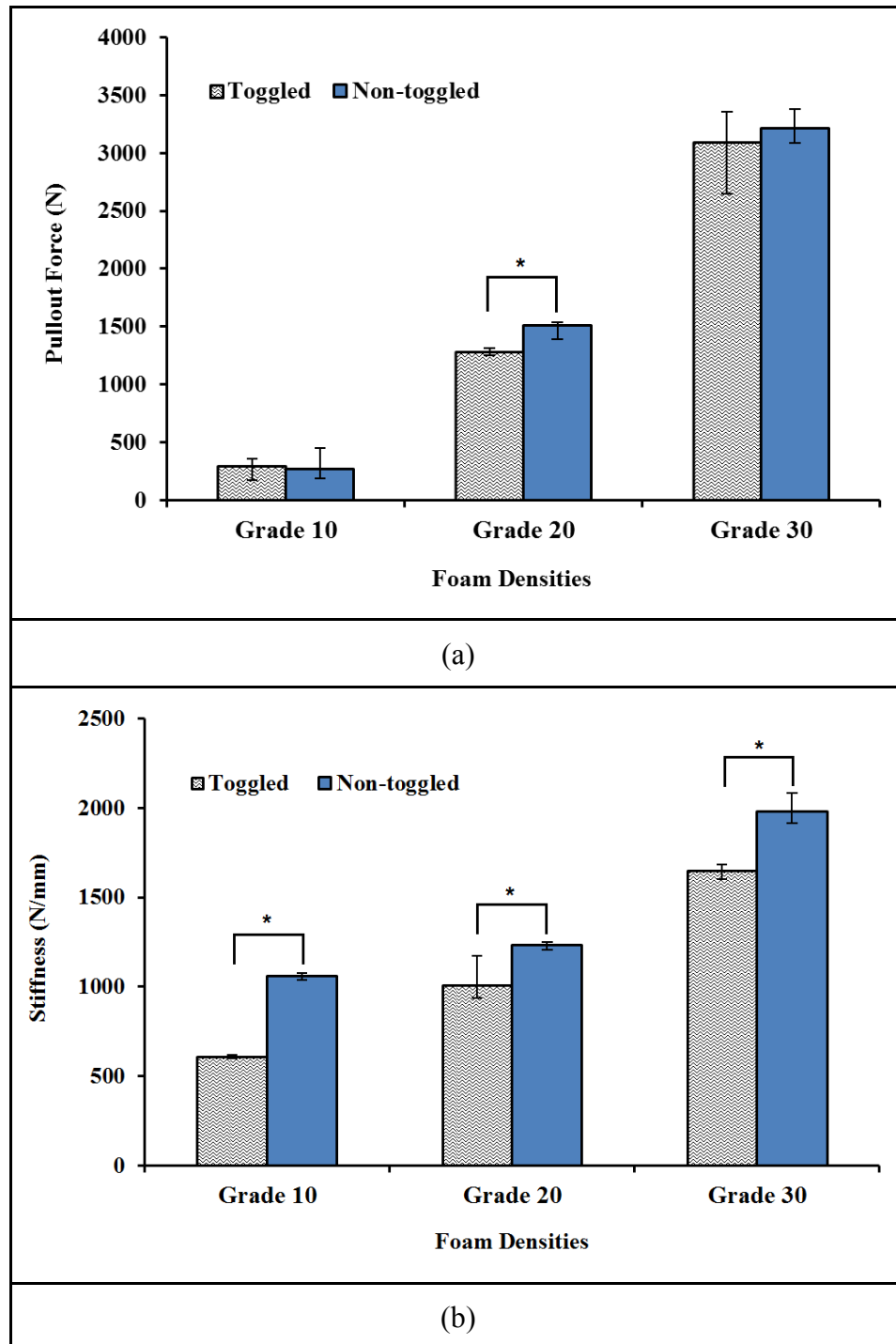

Figure 4.6 Comparison of toggled and non-toggled screws in three densities for: (a) pullout force, (b) stiffness. Asterisk (*) denotes a significant difference

4.1.3 Relationships between indentation force and insertional torque with pullout force and stiffness

Using Pearson's correlation coefficients, the indentation force and insertional torque were significantly correlated to pullout force ($r = 0.99$, $P < 0.0001$ and $r = 0.98$, $P < 0.0001$ respectively). Similarly, significant correlations were demonstrated between indentation force and stiffness ($r = 0.92$, $P < 0.0001$) and insertional torque and stiffness ($r = 0.91$, $P < 0.0001$). These data are summarized in Table 4.4.

Table 4.4 Relationships between indentation force and insertional torque with pullout force and stiffness

Variables	Pullout force		Stiffness	
	r	<i>P</i> -value	r	<i>P</i> -value
Indentation force	0.99	< 0.0001	0.92	< 0.0001
Insertional torque	0.98	< 0.0001	0.91	< 0.0001

4.2 Experimental study on porcine vertebrae

This section presents the measurements for BMD, pedicle anatomical dimensions, pilot hole indentation force, screw insertion torque and pullout force and stiffness for porcine lumbar vertebrae. Potential difference between the vertebral levels for each measurement is explored. The statistical analyses are used to highlight the effects of various toggling modes and vertebral levels on pedicle screw fixation strength (pullout force and stiffness). Potential difference between the toggling modes for pullout force and stiffness are investigated. Furthermore, relationships of the maximum indentation force during pilot hole creation and maximum torque during screw insertion with the fixation strength (pullout force and stiffness) are investigated.

4.2.1 Specimen characteristics

Table 4.5 presents the measurements for BMD and pedicle anatomical dimensions (Ped.A, Ped.H and Ped.W) of all vertebral levels. There was only a significant difference in Ped.A between L1 and L3 ($P = 0.0008$).

Table 4.5 Mean values of the pedicle area (Ped.A), height (Ped.H), width (Ped.W) and the vertebral trabecular density (BMD)

Characteristic	Ped.A (mm ²)	Ped.H (mm)	Ped.W (mm)	BMD (g/cm ³)
L1	728 ± 160	11.7 ± 1.4	7.5 ± 0.7	0.32 ± 0.04
L2	794 ± 237	11.8 ± 1.3	7.7 ± 0.7	0.29 ± 0.05
L3	957 ± 202	11.9 ± 1.2	7.8 ± 0.8	0.28 ± 0.05
Total Mean	827 ± 221	11.8 ± 1.2	7.7 ± 0.7	0.30 ± 0.05

4.2.2 Indentation force, screw insertional torque, pullout force and stiffness with and without toggling

Figure 4.7 presents the typical graph of indentation force as a function of indentation depth in porcine vertebrae. Since the length between the indentation probe tip and the cross sectional plane with maximum diameter was about 15 mm, an initial peak in the indentation force was expected before the probe tip reaches a depth of 20 mm. As the probe contact surface area with the surrounding trabecular bone increases with the insertion depth, the friction force is also increased. Therefore, the maximum indentation force was measured at full probe insertion. Regardless of vertebral level, similar trends were observed in indentation force-indentation depth curves.

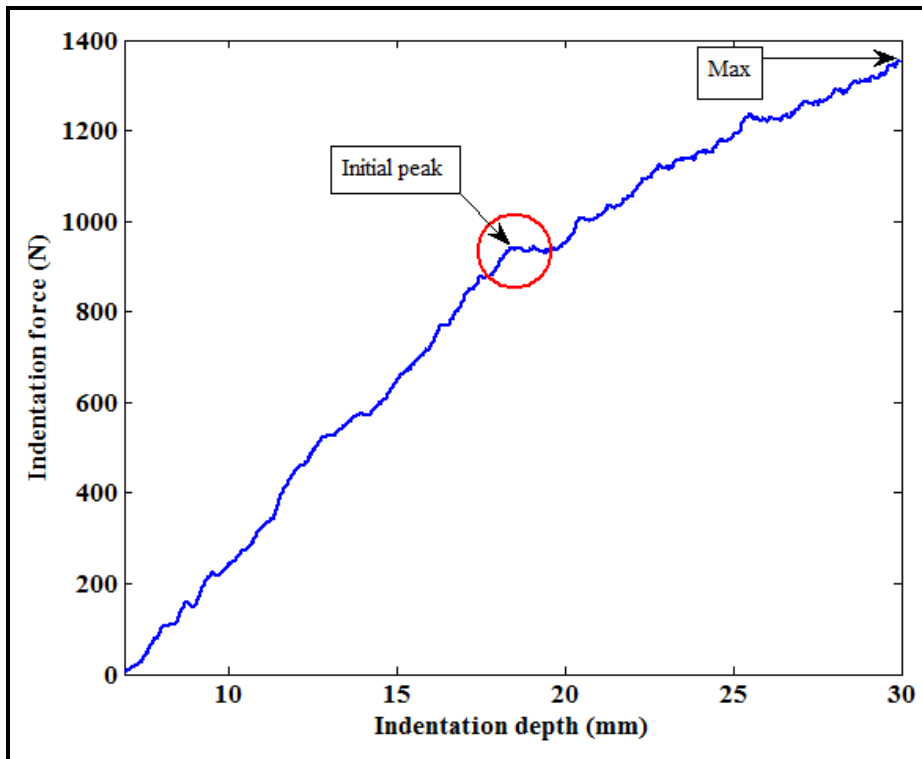

Figure 4.7 Typical graph of indentation force versus indentation depth for porcine vertebrae

Typical curve of insertional torque as a function of insertion depth in porcine vertebrae is depicted in Figure 4.8. Upon further penetration of the vertebra the friction force between the screw surface and the surrounding trabecular bone is increased. Thus, the maximum torque was measured at maximum insertion depth. Similar ramped sinusoidal trends were observed in insertional torque-insertion depth graphs regardless of vertebral level. During screw insertion, radial compressive force is exerted to the trabecular bone. The anisotropic properties of the bone, trabecular bone porosity at any time instant and compression of bone marrow may contributed to the variation in the torque trend.

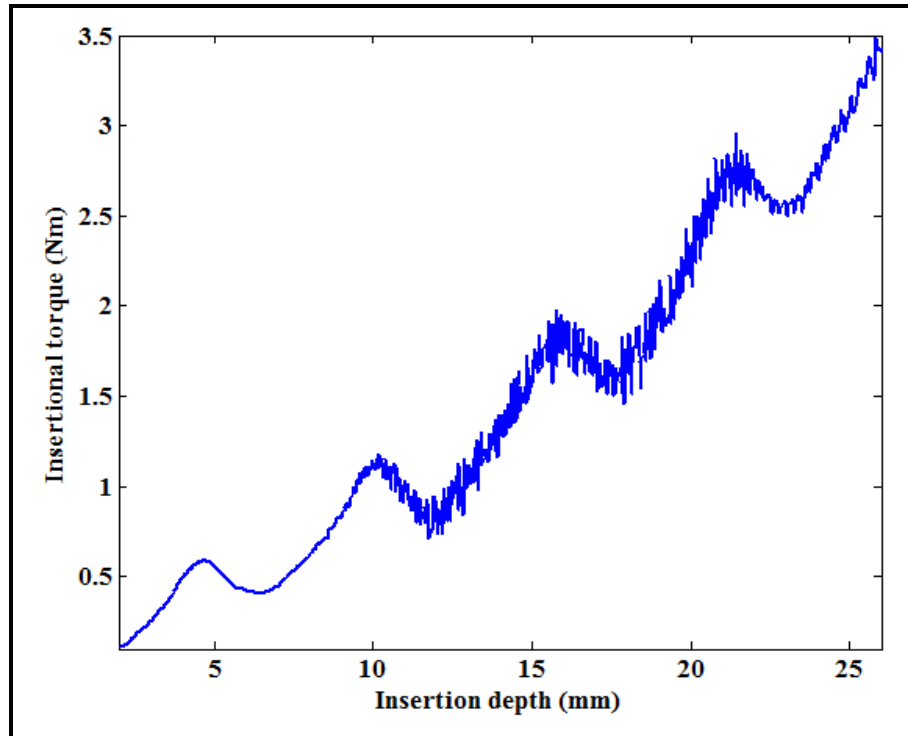

Figure 4.8 Typical graph of insertional torque as a function of insertion depth for porcine vertebrae

The mean and SD values of maximum indentation forces and maximum insertional torques were calculated for 18 trials with indentation force and with insertional torque measurement on each vertebral level (Table 4.6). Indentation force and insertional torque decreased from L1 to L3 vertebral levels. A significant difference in indentation force was observed between L1 and L2 ($P = 0.002$) and between L1 and L3 ($P = 0.0001$). The only significant difference in insertional torque was seen between L1 and L3 ($P = 0.005$).

Table 4.6 Mean \pm SD of maximum indentation force and insertional torque at the three vertebral levels

Vertebral level	Indentation Force (kN)	Insertional Torque (Nm)
L1	1.51 \pm 0.19	3.96 \pm 0.53
L2	1.29 \pm 0.20	3.77 \pm 0.57
L3	1.17 \pm 0.20	3.41 \pm 0.52
Total Mean	1.32 \pm 0.24	3.71 \pm 0.58

Figure 4.9 demonstrates the typical graph of the pullout force as a function of displacement. Regardless of toggling mode and vertebral level, similar trends were registered. The pullout force was recorded as the maximum load at failure and the stiffness was calculated from the slope of the linear part of the curve before the yield point.

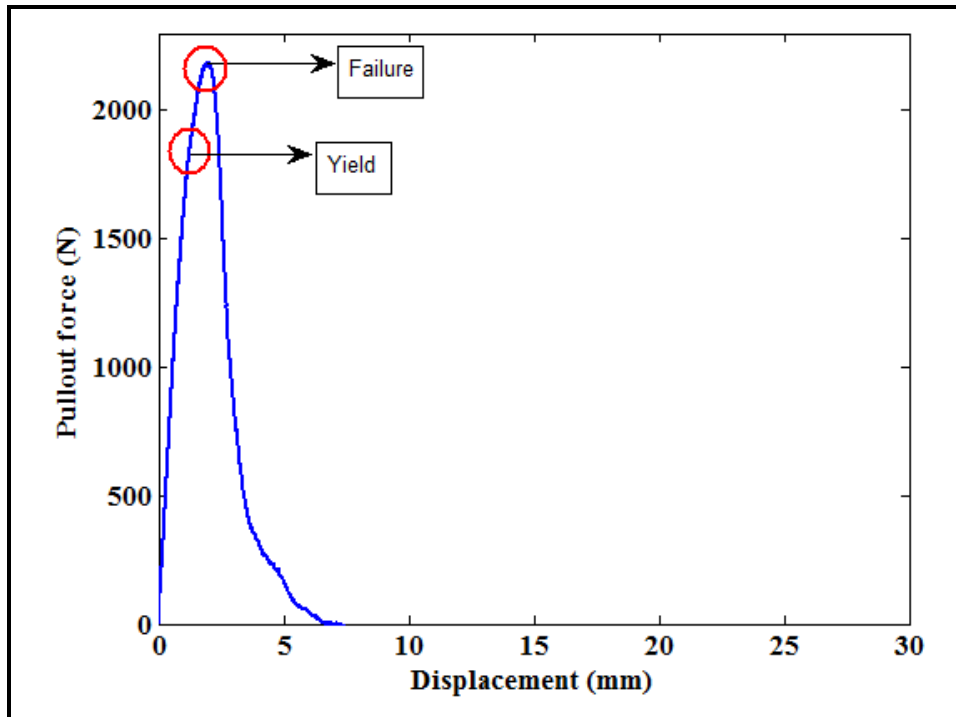

Figure 4.9 Typical graph of pullout force as a function of displacement

Fifty four (54) pullout tests were conducted on both pedicles of 27 vertebrae harvested from nine mature pigs. Four tests were excluded from the analysis since the pedicles failed by fracturing through the pedicle-body junction with the screw remaining intact. In total, the results of 50 pullout tests were considered in the following analysis. Mean and SD values for six pullout tests for each of the three toggling modes and vertebral levels are presented in Table 4.7. No significant difference was observed in pullout force between vertebral levels neither for each toggling mode separately, nor for all toggling modes as a single group. However for stiffness, there was a significant difference between L1 and L3 ($P = 0.002$) when considered all toggling modes as a single group. When CC toggling was applied, significantly different stiffness was observed between L1 and L2 ($P = 0.01$), L1 and L3 ($P =$

0.005) and L2 and L3 ($P = 0.005$). With ML and NT toggling, the only differences were observed for the stiffness between L1 and L3 ($P = 0.01$ and $P = 0.04$ respectively).

Table 4.7 Mean \pm SD of Pullout force and stiffness for different toggling modes at the three vertebral levels

Vertebral level	Pullout force (kN)			Stiffness (kN/mm)		
	CC	ML	NT	CC	ML	NT
L1	2.01 \pm 0.25	2.04 \pm 0.23	2.10 \pm 0.19	1.67 \pm 0.02	1.74 \pm 0.03	1.84 \pm 0.10
L2	1.87 \pm 0.26	2.02 \pm 0.22	1.98 \pm 0.25	1.71 \pm 0.02	1.78 \pm 0.02	1.85 \pm 0.10
L3	1.79 \pm 0.24	1.95 \pm 0.16	1.95 \pm 0.19	1.76 \pm 0.02	1.80 \pm 0.02	1.88 \pm 0.09

4.2.3 Effect of toggling mode and vertebral level on pullout force and stiffness

Figure 4.10 presents the Pareto charts of the main effect of vertebral level (A) and toggling method (B) and their interaction on the pedicle screw pullout force and stiffness. It shows that both the vertebral level and toggling method significantly affect the pullout force and stiffness and that their interaction (AB) affects only the stiffness. Anatomically higher vertebral level (L1) yields an increase in the pullout force whereas lower vertebral level (L3) leads to an increase in the stiffness. Table 4.8 demonstrates the P -values of all effects on the pullout force and stiffness.

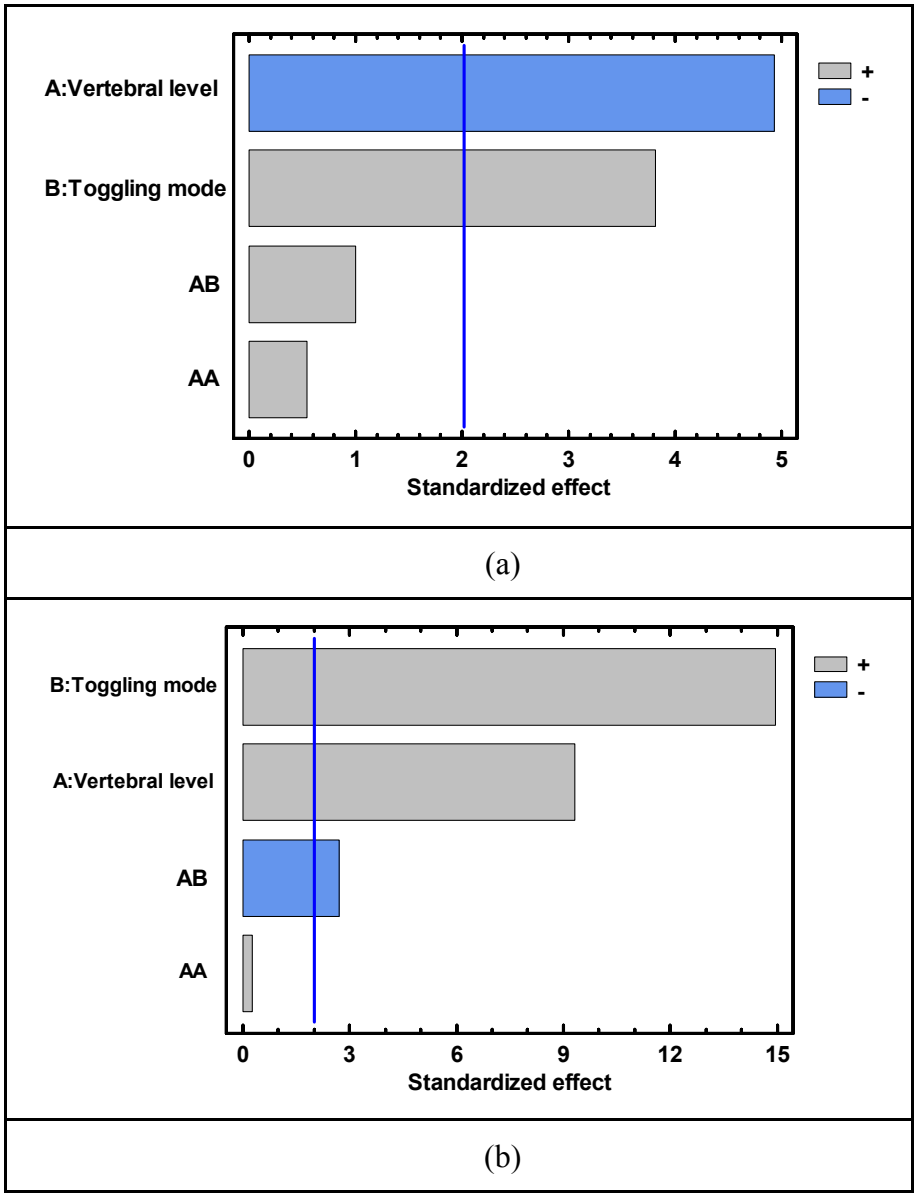

Figure 4.10 Pareto chart for the significance of the effect of toggling mode and vertebral level on: (a) Pullout force, (b) stiffness

Table 4.8 Significance of the effect of vertebral level and toggling mode on the pullout force and stiffness. Asterisk (*) denotes as significant effect

Dependent variables	Independent variables and interactions	<i>P</i> -value
Pullout Force	A: Vertebral Level	<0.0001*
	B: Loading Condition	0.0004*
	AB	0.32
	AA	0.58
Stiffness	A: Vertebral Level	<0.0001*
	B: Loading Condition	<0.0001*
	AB	0.01*
	AA	0.79

The 3D response surface models of pullout force and stiffness are depicted in Figure 4.11. The highest value of pullout force is observed at L1 without toggling whereas the lowest pullout force is shown at L3 after CC toggling. On the reverse, the highest stiffness is observed at L3 without toggling while the lowest stiffness resulted from CC toggling at L1. As presented in Figure 4.11, changing the vertebral level from L1 to L3 leads to decreased pullout force and increased stiffness. The highest pullout force and stiffness are observed without toggling whereas the lowest pullout force and stiffness are shown after CC toggling. The change in pullout force and stiffness is linear with toggling mode and vertebral level.

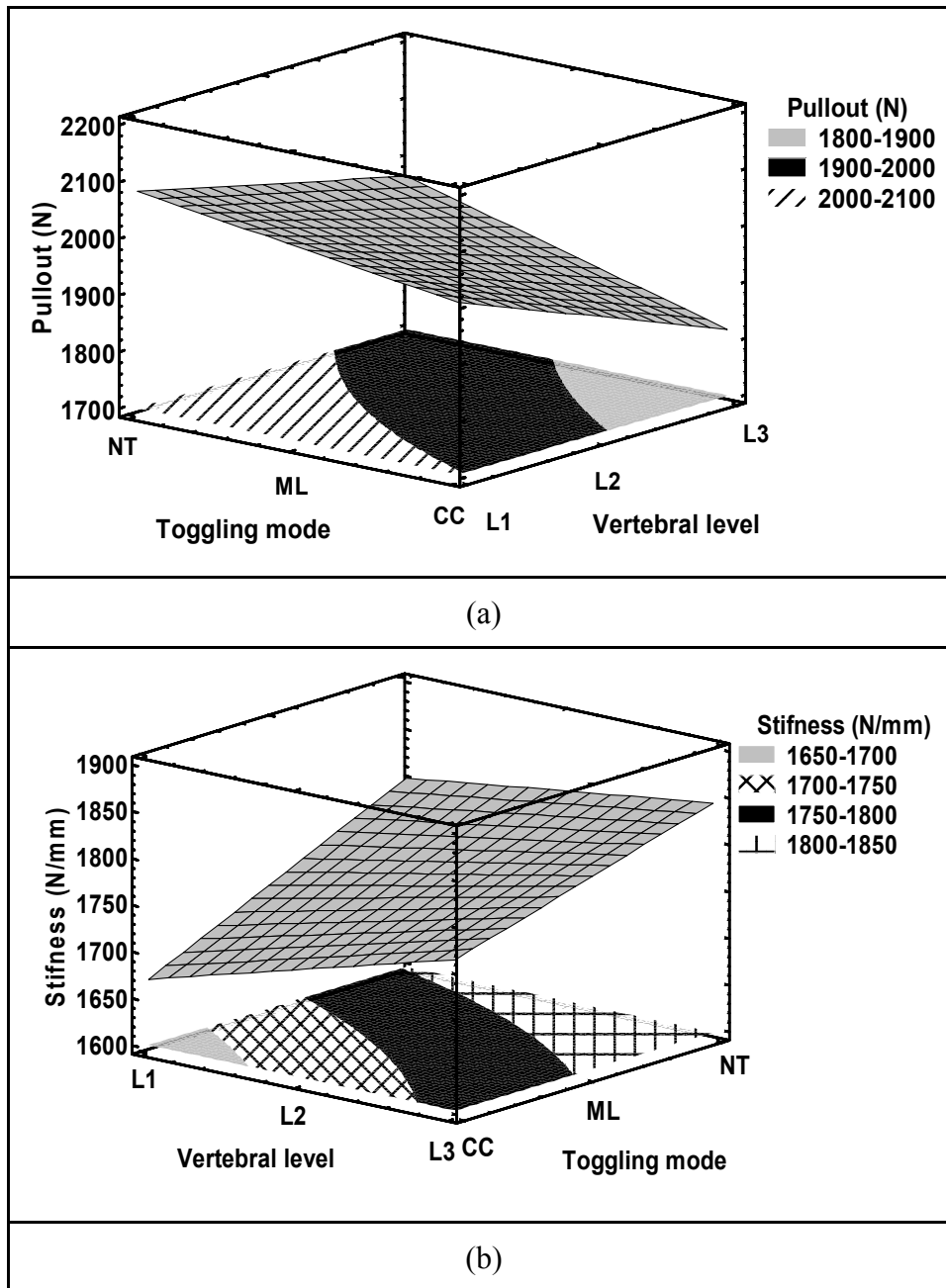

Figure 4.11 2D contour plot of (a) pullout force (b) stiffness

According to Figure 4.12 (a), the pullout force after CC toggling was significantly lower than without toggling ($P = 0.02$). No significant difference was observed between ML toggling and no toggling. In addition, there was a significant difference between CC and ML toggling ($P = 0.03$). The stiffness (Figure 4.12 (b)) following CC and ML toggling was significantly

lower than without toggling ($P < 0.0001$ and $P = 0.0002$ respectively). In addition, a significant difference was observed between CC and ML toggling ($P = 0.0003$).

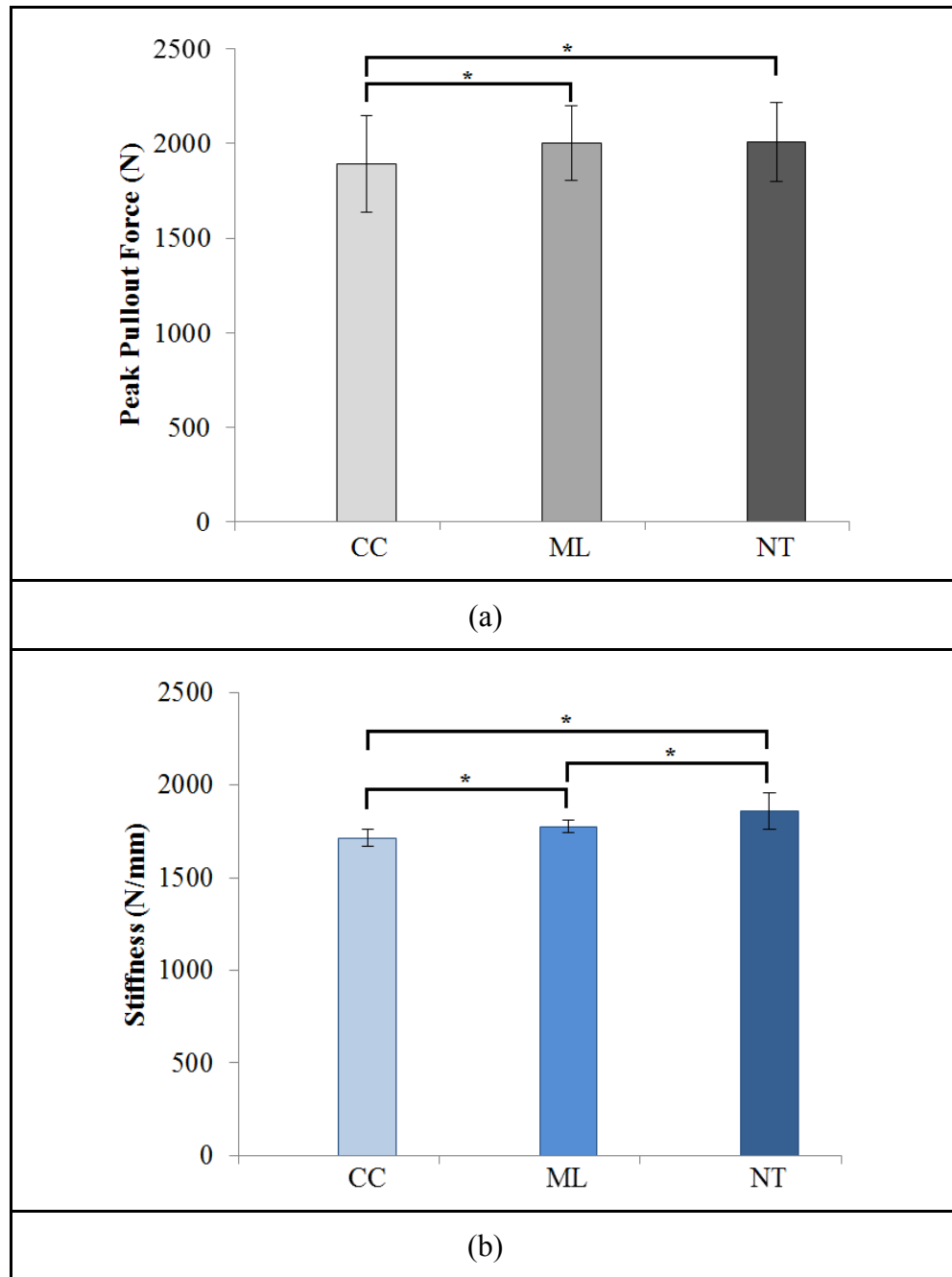

Figure 4.12 Comparison of the effects of toggling modes on: (a) pullout force, (b) stiffness. Asterisk (*) denotes a significant difference

According to Figures 4.10-4.12, it is understood that although toggling mode has a significant effect on the pullout force, the variable with the most significant effect is vertebral level. The contribution of toggling mode to the variation of stiffness is dominant with respect to the vertebral level.

4.2.4 Relationships between vertebral intrinsic properties and measurements during screw insertion with pullout force and stiffness

Table 4.9 presents the correlations and significance levels of all measured variables with the pullout force with different toggling modes. BMD, insertional torque and indentation force have strong positive correlations with the pullout force after CC ($0.81 < r < 0.88$), ML ($0.71 < r < 0.77$) and no toggling ($0.81 < r < 0.85$, Table 4.9). The stiffness is significantly and inversely correlated to pullout force after CC toggling and with no toggling ($r = -0.79$, $P = 0.0008$ and $r = -0.67$, $P = 0.003$ respectively).

Table 4.9 Correlations and significance levels of different measured variables with pullout force after CC, ML and NT toggling.
Asterisk (*) denotes as significant

Variables	Pullout force					
	CC		ML		NT	
	r	P-value	r	P-value	r	P-value
BMD	0.88	<0.0001*	0.76	0.0002*	0.85	<0.0001*
Insertional torque	0.85	<0.0001*	0.77	0.0002*	0.84	0.0001*
Indentation force	0.81	0.0001*	0.71	0.0009*	0.81	0.0001*
Stiffness	-0.72	0.001*	-0.07	0.76	-0.67	0.004*
Ped.A	-0.63	0.009*	-0.44	0.06	-0.45	0.07
Ped.H	-0.43	0.09	-0.43	0.07	-0.35	0.18
Ped.W	0.01	0.95	-0.07	0.77	0.16	0.53

Table 4.10 illustrates the indentation force, insertional torque and BMD have strong and significant inverse correlations with the stiffness after CC and NT toggling ($-0.60 < r < -0.85$ and $-0.69 < r < -0.84$ respectively). Ped.A is positively correlated to stiffness after CC

toggling ($r = 0.70$, $P = 0.003$) and without toggling ($r = 0.64$, $P = 0.007$). No significant correlation is found between measured variables and the stiffness after ML toggling. Furthermore, BMD was significantly correlated to indentation force and insertional torque ($r = 0.68$, $P < 0.0001$ and $r = 0.50$, $P = 0.0003$ respectively).

Table 4.10 Correlations and significance levels of different measured variables with stiffness after CC, ML and NT toggling. Asterisk (*) denotes as significant

Variables	Stiffness					
	CC		ML		NT	
	r	P-value	r	P-value	r	P-value
Indentation force	-0.85	<0.0001*	-0.43	0.07	-0.84	<0.0001*
Insertional torque	-0.75	0.0009*	0.08	0.75	-0.83	0.0001*
BMD	-0.60	0.02*	-0.26	0.2	-0.69	0.003*
Ped.A	0.70	0.003*	0.09	0.72	0.64	0.007*
Ped.H	0.21	0.43	0.07	0.76	0.41	0.11
Ped.W	-0.01	0.92	0.1	0.7	0.05	0.83

Forward stepwise multiple regression analysis was implemented to construct comprehensive models with improved estimation ability for pedicle screw pullout force and stiffness. To account for the effects of toggling modes, multiple regressions are presented for each toggling mode separately. Given all measured variables including: indentation force, insertional torque, BMD and Ped.A to forward stepwise multiple regression analysis, it is indicated that linear combination of BMD and insertional torque improves the estimation of pullout force after CC toggling up to 97% (Equation (4.1)). The same combination of variables estimates 86% of variation in pullout force after ML toggling (Equation (4.2)). For the pullout force with no toggling, the BMD is the single variable which estimates 82% of variation in pullout force (Equation (4.3)).

The estimation models for pullout force after CC toggling and without toggling are as follow:

$$F_{PCC} = 178 \times F_T + 2.7 \times BMD + 438 \quad (R^2 = 0.97, P < 0.0001) \quad (4.1)$$

$$F_{PML} = 277 \times F_T + 2 \times BMD + 421 \quad (R^2 = 0.86, P < 0.0001) \quad (4.2)$$

$$F_{PNT} = 4 \times BMD - 0.35 \times P_A + 1117 \quad (R^2 = 0.82, P < 0.0001) \quad (4.3)$$

Where: F_{PCC} is pullout force (kN) after CC toggling, F_{PML} is pullout force (kN) after ML toggling, F_{PNT} is pullout force (kN) without toggling, F_T is insertional torque (Nm), BMD is bone mineral density (g/cm^3) and P_A is pedicle area (mm^2).

Forward stepwise multiple regression analysis for the stiffness indicates that the indentation force is the single variable that strongly estimates the variation in stiffness after CC toggling or without toggling (Equation (4.4)-(4.5)). In the presence of indentation force, no other measured variables such as BMD, insertional torque and Ped.A which correlated to stiffness after CC toggling or without toggling can improve the estimation ability to the models. As demonstrated earlier in Figure 4.12 (b), there is a very small variation in stiffness after ML toggling. Thus, none of the given variables to multiple regression analysis can provide estimation model for the variation in stiffness after ML toggling. The estimation models for stiffness after CC toggling and without toggling are as follow:

$$s_{CC} = -0.14 \times F_I + 1895 \quad (R^2 = 0.73, P < 0.0001) \quad (4.4)$$

$$s_{NT} = -0.08 \times F_I + 1920 \quad (R^2 = 0.71, P < 0.0001) \quad (4.5)$$

Where: s_{CC} is stiffness (kN/mm) after CC toggling, s_{NT} is stiffness (kN/mm) without toggling, F_I is indentation force (kN).

CHAPTER 5

DISCUSSION

Pedicle screw fixation has been demonstrated as one of the standard treatment method for various spinal disorders by providing rigid fixation and smaller number of fused segments. Despite all the benefits, screw loosening with potential pseudarthrosis or loss of correction leading to revision surgery is a major concern. To this end, prediction of pedicle screw fixation strength have been attempted in numerous biomechanical investigations. Various predictive methods including measurements of BMD, insertional torque, screw stiffness, pedicle geometry have been suggested (Brantley et al., 1994; Daftari, Horton and Hutton, 1994; Lee, Park and Shin, 2012; Mehta et al., 2011; Okuyama et al., 1993; Wittenberg et al., 1993; Zdeblick et al., 1993). However, the potential use of one or several of these methods to help the surgical planning remains to be investigated. Furthermore, other factors such as the force generated during pilot hole creation may contribute to the estimation of fixation strength.

The first objective (O1) of this research work was to develop and validate instruments for measuring the indentation force during pilot hole performance and the insertional torque during screw insertion. The developed instruments and methods of measurement were validated using synthetic bone surrogates in protocol 1. The experimental sources of variation could arise from surgical simulation, specimen installation on the test apparatus, load and displacement measurements, and specimen distribution. Thus, the pilot hole creation and screw insertion were performed using machine controlled system to improve repeatability. Small variations along PU foam blocks as bone surrogates allow minimization of inter specimen variation and anatomical constraints of cadaveric bones and verifications for the repeatability. For indentation test, it was assumed that the only indentation force needed via the machine controlled procedure is likely to be the axial load. The slow indentation speed applied in this study, although was not that of applied by surgeons during manual pilot hole creation, was considered to reduce the high insertion energy required to

overcome the friction against the side of the indenter and the resistance force at the indenter tip. For insertional torque measurement, the machine controlled screw insertion and the experimental test bench allowed repeatable torque measurement via a constant angular insertion speed and axial load.

The second objective (O2) of this research work was to compare the screw loosening mechanisms through toggling in different directions and evaluate their effects on pullout force and stiffness. Three modes of toggling such as CC, ML and NT toggling were compared on three vertebral levels ranging from L1 to L3 in mature porcine specimens in protocol 2. Mature porcine vertebrae were used to reduce the inter-individual variability, inconsistent regional BMD and complex effects from cartilaginous growth plates. The analysis of results demonstrated a significant effect of screw toggling modes on the pullout force and stiffness. Therefore, the second hypothesis (H2) of this research work was verified. The comparison between the toggling modes demonstrated the most significant decrease in the pullout force and the stiffness after CC toggling. Therefore, it should be included to biomechanical evaluation of pedicle screw fixation strength. Although the effect of toggling was significant on the pullout force, it was more important on the stiffness at all vertebral levels. This may be caused by the screw behaviour under toggling being affected by the pedicle geometry (Brantley et al., 1994; Hirano et al., 1997; Zdeblick et al., 1993). Actually, significant correlations were found in this study between the pedicle cross-section area and the stiffness for CC and NT toggling, and with pullout force only for CC toggling. Regardless of vertebral level, the stiffness was significantly different between all toggling modes while pullout forces only showed a significant difference between CC and no toggling and between CC and ML toggling. To account for the effect of factors such as bone density which is controllable in synthetic bone surrogates as opposed to cadaveric studies, a secondary objective was explored in protocol 1 to evaluate the effects of screw toggling on pullout force and stiffness in synthetic bone surrogates of different densities. Since the synthetic bone surrogates were made from isotropic polyurethane foam material which exhibit same behaviour in response to applied load in different directions, only one toggling mode was performed. PU foams blocks of density grades 10 and 20 were used to simulate

material properties of human vertebral cancellous bone (Banse, Sims and Bailey, 2002). In addition, grade 30 foams were used in this study to simulate high density vertebral bone of large animals such as mature pigs. The study on synthetic bone surrogates also indicated a significant effect of screw toggling on the pullout force but more importantly on stiffness. Actually, the stiffness was significantly different between toggled and non-toggled screws at all density grades while pullout forces only showed a significant difference for grade 20 foams. This effect of toggling on stiffness is in agreement with previous studies (İnceoğlu et al., 2006; Myers et al., 1996; Zdeblick et al., 1993; Zindrick et al., 1986) which showed that cyclic loading of pedicle screws reduces the stiffness at the screw-bone interface through compacting the surrounding cancellous bone. In fact, the transverse load can develop compressive stress and accumulation along the screw-bone interface which thereby leads to loss of fixation and pullout. Lotz et al. (1997) compared the pullout test with and without cephalocaudal toggling on pedicle screws with and without cement augmentation in human cadaveric vertebrae. They did not find any significant difference between the two groups. However, they did not provide the analysis for the stiffness. The discrepancy between their results and the present research work is speculated to be due to the variation in source of specimens. They performed toggling and no toggling pullout tests on two different groups of vertebrae and therefore the variation in BMD from individual vertebrae may affected their results. Other factors may also affect the results including screw designs, pedicle morphology in human vertebrae, method of hole preparation or the screw insertion depth (Brantley et al., 1994; Halvorson et al., 1994; Wittenberg et al., 1993; Zdeblick et al., 1993).

The study on synthetic bone surrogate indicated that foam density has a significant effect on the stiffness, but more importantly on the pullout force. The pullout force and stiffness were significantly higher in high density foams than in low density counterparts. This is in agreement with the studies showing higher pullout force for higher density using foam materials (Chao et al., 2008; Kim, Choi and Rhyu, 2012; Patel, Shepherd and Hukins, 2010) or human cadaveric vertebral bone (Daftari, Horton and Hutton, 1994; Deckelmann et al., 2010; Mehta et al., 2011). The study on porcine vertebrae also demonstrated an important correlation ($P < 0.001$, $r > 0.76$) between the pullout force and the BMD regardless of

toggling mode (Halvorson et al., 1994; Mehta et al., 2011; Soshi et al., 1991; Wittenberg et al., 1993).

The study on porcine specimens demonstrated that changing the vertebral level from L1 to L3 leads to a significant decrease in pullout force and a significant increase in stiffness. On one hand, this effect may be explained by the significant positive correlation between BMD and pullout force ($r = 0.88, P < 0.0001$ and $r = 0.76, P = 0.0002$ and $r = 0.85, P < 0.0001$ for CC, ML and no toggling respectively) and the inverse correlation with stiffness ($r = -0.60, P = 0.02$ and $r = -0.69, P = 0.003$ for CC and no toggling respectively). On the other hand, the effect of vertebral level on stiffness may be attributed to the significant positive correlation between Ped.A and stiffness ($r = 0.70, P = 0.003$ and $r = 0.64, P = 0.007$ for CC and no toggling respectively) and the inverse correlation with pullout force after CC toggling ($r = -0.63, P = 0.009$). The aforementioned explanations compare well with other studies (Brantley et al., 1994; Myers et al., 1996; Zdeblick et al., 1993) which have reported a significant correlation between the pedicle size and the stiffness and an inverse correlation with cyclic pullout force in human cadaveric vertebrae. The latter reflects the fixation is stronger when the pedicle screw fills a greater proportion of the pedicle area.

The effects of toggling modes on pedicle screw fixation strength of various bone surrogate densities was presented in a conference paper of the *36th Annual International Conference of the IEEE Engineering in Medicine and Biology Society (EMBC'14)*, which was held in Chicago, USA, in August 26 - 30, 2014 (APPENDIX II). The study of the effect of toggling modes on porcine specimens was presented at the *10th Meeting of the International Research Society of Spinal Deformities (IRSSD 2014)*, which was held in Sapporo, Japan, in June 29 - July 30, 2014 (APPENDIX III) and a journal article was prepared and submitted to the *Journal of Biomechanical Engineering* (APPENDIX IV).

The third objective (O3) of this research work was to establish relationships between indentation force and insertional torque measurements and pullout force and stiffness with and without toggling. To avoid the confounding effect of different screw size and designs

(Brantley et al., 1994; Krenn et al., 2008; Mehta et al., 2011) and insertion techniques (Halvorson et al., 1994; Wittenberg et al., 1993; Zdeblick et al., 1993) on fixation strength, these factors were kept constant throughout the study. The relationships were initially explored on synthetic bone surrogates of different densities using developed and validated instruments for indentation force measurement while performing a pilot hole and for insertional torque measurement during screw insertion in protocol 1 through the first objective of this thesis. Significant strong correlations were found between indentation force and pullout force and stiffness with and without toggling for all densities ($r > 0.90$, $P < 0.0001$). Similarly, insertional torque significantly correlated to pullout force and stiffness with and without toggling for all densities ($r > 0.90$, $P < 0.0001$). The study on porcine specimens in protocol 2 demonstrated that the indentation force, the insertional torque and the BMD are significantly correlated to the pullout force after each toggling mode ($0.71 < r < 0.88$, $P < 0.001$). The same factors showed significant inverse correlations to the stiffness after CC toggling or with no toggling ($-0.60 < r < -0.85$, $P < 0.05$). Furthermore, significant inverse correlations were observed between the stiffness and the pullout force after CC toggling or with no toggling ($r = -0.72$, $P = 0.001$, $r = -0.67$, $P = 0.004$ respectively). Combined use of these measurements showed greater estimation of the variation in pullout force and stiffness. Multiple regression analyses showed different equations for estimation of pullout force for different toggling modes. Linear combination of BMD and insertional torque measurement improved the estimation of pullout force after CC and ML toggling, explaining up to 97% and 86% of the variability respectively. However, 82% of the variability in pullout force with no toggling could be explained from the linear combination of BMD and Ped.A measurement. For the stiffness, indentation force measurement while performing a pilot hole was the single variable showing the improved estimation of the stiffness after CC toggling or with no toggling ($R^2 = 0.73$, $P < 0.001$ and $R^2 = 0.71$, $P < 0.0001$ respectively). The regression model for pullout force after toggling in this study provides better estimation ability than the model proposed by Myers et al. (1996) ($R^2 = 0.51$, $P = 0.0002$). Their model was constructed from the linear combination of insertional torque, BMD and the stiffness which was calculated from the first cycle of loading during cyclic bending pullout test. The significant correlation between the insertional torque as an

individual variable and the pullout force in the present study is favourably compared to those studies reporting significant correlation between insertional torque and pullout force under cyclic loading on human cadaveric vertebrae (Myers et al., 1996; Zdeblick et al., 1993). Some studies on synthetic bone surrogates or animal cadaveric vertebrae also demonstrated a good correlation between insertional torque and axial pullout force (Daftari, Horton and Hutton, 1994; Hashemi, Bednar and Ziada, 2009; Hsu et al., 2005). In contrast, several studies could not establish a significant relationship between insertional torque and pullout force under axial loading on human cadaveric vertebrae (Kwok et al., 1996; Mehta et al., 2011; Reitman, Nguyen and Fogel, 2004) or on calf vertebrae (Inceoglu, Ferrara and McLain, 2004). As the results of multiple regression analyses in the present research study suggest, the discrepancies in the relationship between insertional torque and pullout force may be attributed to the method of pullout force measurement with or without cyclic loading. The studies that failed to find a relationship between the insertional torque and pullout force, often perform only axial pullout tests. In fact, the insertional torque yields from the compression of trabecular bone as well as the friction between the screw threads and the trabecular bone. During pullout, however, the trabeculae fail in shear. The anisotropy of trabecular bone, therefore, may lead to different mechanical behaviour in response to different mechanical loadings. Accordingly, those investigators who indicated significant relationship between insertional torque and pullout force, have performed a pullout force under cyclic loading which also induce compression force to the trabeculae along the length of the screw. Moreover, the use of different screw types may result in different relationships (Kwok et al., 1996; Mehta et al., 2011). This research work was the first to investigate the relationship between the indentation force while performing the pilot hole and the pullout force and stiffness with and without toggling. Deckelmann et al. (2010) performed indentation force measurements within vertebral body after pilot hole creation using a custom-made indenter to estimate the trabecular bone strength at an area which the screw tip lies. They reported a significant correlation ($r = 0.69$, $P = 0.04$) between the indentation force and the load at cut out from cyclic sinusoidal loading until screw loosening occur.

A conference article on the estimation of pedicle screw fixation strength from indentation force measurement while performing pilot hole and insertional torque measurement during pedicle screw insertion in bone surrogates of different densities was presented in 36th *Annual International Conference of the IEEE Engineering in Medicine and Biology Society (EMBC'14)*, which was held in Chicago, USA, in August 26 - 30, 2014 (APPENDIX I).

There are some limitations to the present study including the limited number of specimens. Nevertheless, despite the small number of specimens, statistically significant effects were found on the pullout force and stiffness from screw loosening through various toggling modes. In addition, factors with statistically significant relationship to pullout force and stiffness were identified. Moreover, the screw loosening mechanism investigated in this study may not comprehensively simulate *in vivo* forces. In physiological situation, one or more toggling mode or other combination of loads may be exerted on pedicle screws. Pedicle screw insertion in this study was not performed under radiographic navigation. However, adequate screw placement was ensured using a custom-made experimental fixture that allowed adjusting the screw insertion angle and the pedicle trajectory. The porcine specimens used in this study have about twice greater BMD than human vertebrae (Aslani, Hukins and Shepherd, 2012). Thus, care should be taken not to extrapolate the findings of present study to weak osteoporotic vertebrae and additional experiments would be required. However, since the pedicle anatomy of porcine vertebrae, having a greater pedicle height than width, are comparable to human L3 and cephalad vertebrae (Zindrick et al., 1987), the findings of this study would not affect the conclusion on human healthy vertebrae. Finally, all the investigations throughout this study were performed only for one pedicle screw type. Thus, further studies are required to investigate the findings for other screw types.

According to experimental investigations in this thesis, systematic use of toggling and in particular CC toggling is recommended for *in vitro* evaluation of pedicle screw fixation strength. The controversy in the literature regarding to predictive ability of insertional torque measurement on pedicle screw fixation strength led to development of instruments and methods for measuring indentation force and insertional torque in this study. As a result,

insertional torque measurement together with BMD measurement could provide high estimation ability for the pullout force. The best estimation of stiffness was provided by measuring the indentation force during pilot hole perforation. The resulting information is beneficial for medical industry to design and develop new surgical instruments for intraoperative measurement of related factors to pedicle screw fixation strength. The identified factors in this study may also help improve the estimation of screw fixation strength in other screw-based construct surgeries such as the femur, tibia and humerus (Lin et al., 2012; Suhm et al., 2007). The estimation of pedicle screw fixation strength can be beneficial for surgeons to distinguish patients at risk for loss of screw fixation strength, the need for supplemental techniques (screw augmentation by bone cements, sublaminar wires or hooks) and identification of the number of vertebral levels to be fused. It is also helpful for the patients postoperative managements in terms of using bracing or early immobilization.

CONCLUSION

Pedicle screw fixation is a well-established surgical method for the treatment of spinal fracture, degenerative changes and deformities. However, reported rates of screw failure urged medical community to evaluate the fixation strength. Despite all the efforts, as our review of literature indicates, the mechanism of pedicle screw loosening and its effect on the pedicle screw fixation strength is not well understood. Moreover, no reliable *in vitro* or *in vivo* models are available until now to estimate the screw resistance to pullout. Estimation of pedicle screw fixation strength would help the surgeons to decide on the use of supplemental techniques, the number of vertebrae to be fused or the duration of postoperative immobilization.

The main objective of this doctoral project was to improve the understanding on the mechanisms of pedicle screw loosening and the factors related to pedicle screw fixation strength. The two hypotheses of this research project were verified through three objectives and two experimental protocols on synthetic bone surrogates and porcine vertebrae. From the first specific objective (O1), instruments for measuring indentation force during pilot hole creation and screw insertional torque were developed and validated for the repeatability. The effects from different screw toggling modes on pedicle screw fixation strength were highlighted through the second objective (O2). The factors related to pedicle screw fixation strength were identified from the third objective (O3). The first hypothesis (H1) was confirmed by the identification of a strong correlation between the indentation force and insertional torque with screw pullout force and stiffness. The second hypothesis (H2) was supported by the demonstration of the significant effect of screw toggling on pullout force and stiffness. From the analysis and discussion of the results, the following conclusions are formulated:

- I. Pedicle screw toggling significantly affects the pedicle screw pullout force and stiffness. CC toggling reduces the pullout force and stiffness more significantly than ML toggling. This reinforces the systematic use of CC toggling in *in vitro*

investigations to better assess the pedicle screw fixation strength. Furthermore, although toggling mode has a significant effect on the pullout force, the variable with the most significant effect is vertebral level. The contribution of pedicle screw toggling to the variation of stiffness is dominant at all vertebral levels;

- II. The indentation force, the insertional torque and the BMD have significant relationships with the pedicle screw pullout force and stiffness after each toggling mode. The measurement of BMD using a CT scanner together with insertional torque measurement during screw insertion provides a valuable estimation on the pedicle screw pullout force after CC or ML toggling. However, if one considers the pullout force with no toggling, measurement of BMD and pedicle area are the most important factors in the regression model. Regardless of toggling mode, the indentation force measurement during pilot hole creation gives a strong estimation of the pedicle screw fixation stiffness from the regression models.

The author's main contribution was to improve the knowledge of the mechanisms of pedicle screw loosening and their effect on pedicle screw pullout force and stiffness alongside with identification of the factors which have the most important relationship to the pedicle screw pullout force and stiffness. These factors have good potential for being used for estimating the pedicle screw fixation strength intra or pre-operatively. Thus, this study is a milestone towards the clinical application of pedicle screw fixation strength prediction. Additional experiments may need to be performed to validate the obtained estimation equations as the real potential for estimation of pedicle screw fixation strength and to evaluate the effects of combined toggling modes together with the identified estimation factors. Following that, the appropriate instruments may be designed or improved to be used in the operation room for estimating pedicle screw fixation strength.

RECOMMENDATIONS

As mentioned earlier in the introduction, the main purpose of this study was to propose new strategies for understanding the pedicle screw loosening mechanisms and prediction the fixation strength as a function of loads and torques generated during cavity creation and screw insertion into the vertebrae. To complete the study, following investigations are suggested:

- 1) Further studies are required to validate the estimation models for pedicle screw pullout force and stiffness. In addition, verifications should be performed on human osteoporotic vertebrae where the bone material and structural properties are subject to change relative to healthy bone;
- 2) Since the screw-bone interface can affect the fixation stiffness and strength and different screw designs exhibit different mechanical behaviour, further investigations should be performed for various screw designs for adequate generalization of the predictive model;
- 3) All biomechanical tests in this study including probe indentation, screw insertion, toggling and pullout tests mainly alter the trabecular bone within the vertebrae. Therefore, complementary study of microstructural properties of trabecular bone surrounding the pedicle screw may strengthen the predictive model;
- 4) Finite element modeling of cavity creation, screw insertion into the vertebra and subsequently toggling and pullout test can be conducted to study the trabecular bone behaviour during each biomechanical test and compare to corresponding *in vitro* tests. Thereby, the stress/strain behaviour of the bone can be studied in greater details. This method is also fast, cost and time effective for repeated mechanical testing of new screw designs, various bone qualities and different pedicle geometries from different individuals;

- 5) The ultimate complementary step would be the development of surgical instruments equipped with load/torque cell enabling intraoperative measurements of indentation force during cavity creation and insertional torque during screw placement. These measurements can then be transferred to specific designed software (e.g. a software with ability to add the CT scan of individuals spine, calculate the BMD and pedicle geometry, and predict the fixation stiffness and strength from given information of indentation force and insertional torque) to help the surgeons estimate the stability and strength of pedicle screw.

APPENDIX I

CONFERENCE ARTICLE 1: ESTIMATION OF PEDICLE SCREW FIXATION STRENGTH FROM PROBE INDENTATION FORCE AND SCREW INSERTION TORQUE: A BIOMECHANICAL STUDY ON BONE SURROGATE OF VARIOUS DENSITIES

In proceeding of 36th Annual International Conference of the IEEE Engineering in Medicine and Biology Society (EMBC'14) 26-30 August 2014, Chicago, IL, USA

Article No: ISME2012-3476

H.N. Mehmanparast¹, JM. Mac-Thiong², and Y. Petit¹

1. Department of Mechanical Engineering, École de Technologie Supérieure (ÉTS), Canada, H3C 1K3.
2. Division of Orthopedic Surgery, University of Montreal, Canada, H4J 1C5.

Corresponding author: hedayeh.mehmanparast-nodehi.1@ens.etsmtl.ca

Abstract— Posterior pedicle screw fixation is commonly used for patients with spinal disorders. However, failure of fixation is reported in many cases and surgeons have only little information. The objective of this study was to assess the correlation between the probe indentation force, screw insertion torque and the pullout force using bone surrogates of different densities. The indentation force and insertion torque were measured using a custom made test bench during screw insertion into polyurethane foam blocks. The two variables were significantly correlated to pullout force and to density. A high correlation was also found between indentation force and the peak insertion torque. The proposed methods for measuring indentation force and screw insertion torque were reproducible. This study suggests that the peak screw insertion torque and the indentation force can predict the screw fixation strength in synthetic bone models. Additional tests should be performed on animal and human specimens to confirm and to translate these findings to clinical applications.

I. INTRODUCTION

Pedicle screw fixation in spinal fracture, degenerative changes and deformities is widely used by orthopedic surgeons. Clinical studies have reported many cases of fixation failure through loosening at screw-bone interface [1-4]. Therefore, screw-bone interface is an important factor affecting pedicle screws fixation strength. Other factors such as screw design, bone quality, pedicle anatomy and insertion technique can also affect the fixation strength [5-7].

Several biomechanical studies have investigated pedicle screw fixation strength using pullout tests, insertion torque measurements or bone indentation tests [6, 8-12]. However, important discrepancies and poor agreements could be observed in the results, possibly because of a lack of standardization and reproducibility.

The present study investigates for the first time, the two mechanical evaluation methods of screw-bone interaction in synthetic model of cancellous bone of different densities. Using custom-made instrumentations, insertion torque and indentation force were assessed in a reproducible manner, and correlated with pullout force. This is considered as a preliminary study before in-vitro evaluation on cadavers.

II. MATERIAL AND METHODS

A. Specimen preparation

This study used polyurethane foams (Sawbones, Pacific Research Laboratories, Vashon, WA, USA) as cancellous bone surrogate to avoid the inhomogeneity, complex anatomical characteristics and inter-subject variability of human vertebral bone density. Thirty six foam blocks of 5cm x 5cm x 4cm with 3 different densities were used to represent vertebral cancellous bone ranging from weak osteoporotic to normal human bone: 0.16 g/cm³ (E=86MPa), 0.32 g/cm³ (E=284MPa) and 0.48 g/cm³ (E=592MPa). Pedicle screws of 5 mm x 35 mm (DePuy Spine, Inc., Raynham, MA, USA) were used for all tests.

B. Test Fixture

Each foam block was embedded into an aluminum box with polyester resin. A custom-made fixture (see Figure 2) composed of a translation table and a universal joint was used to align the specimen and eliminate residual forces. This fixture was designed to provide coaxial alignment of the pedicle with the testing system actuators during the biomechanical tests.

C. Indentation force measurement

The custom-made indentation probe was designed with a conical tip of 3mm major diameter and 100mm length to resemble the spinal pedicle finder surgeons use to create a pilot hole into the pedicle (Figure 1). The indentation probe was secured into the grips of material testing system (858 Bionix II, MTS Corp, Eden Prairie, MN). The test fixture was placed and aligned along with the indenter

longitudinal axis. The indentation was conducted at rate of 1mm/sec to a depth of 25mm. The load and displacement were recorded during indentation. Indentation force was defined as the maximum load during penetration of polyurethane foam specimens.

D. Insertion torque measurement

Following the indentation test, the test fixture was installed in a custom-made test bench for torque measurement (Figure 2). The test frame is composed of a rotating motor seated on a plate free to slide vertically. A set of counterweights allow adjusting the longitudinal force applied during screw insertion. In this study, this force was set to 11.1 N. The screw driver was secured under the rotating motor using grips with a wedged shape slot and a 5 mm x 35 mm pedicle screw was secured into the screw driver. Once the foam block center was aligned with the screw tip, screw insertion started at rotation speed of 3 r/min until complete insertion of all threads into the foam block.



Figure 1. Custom-made indenter used to measure the maximum indentation force.

The torque and longitudinal force were monitored during the test using a calibrated torque/load cell with maximum torque capacity of 5.7 N.m and axial load capacity of 444.8 N (Model 1516 DMW-100, Bose Corporation, Eden Prairie, MN, USA). The insertion torque was defined as the peak torque for fully inserting the pedicle screw into the foam specimens. Insertion depth was measured using Optotrak 3020 cameras (Northern Digital Inc., Ontario, Canada).

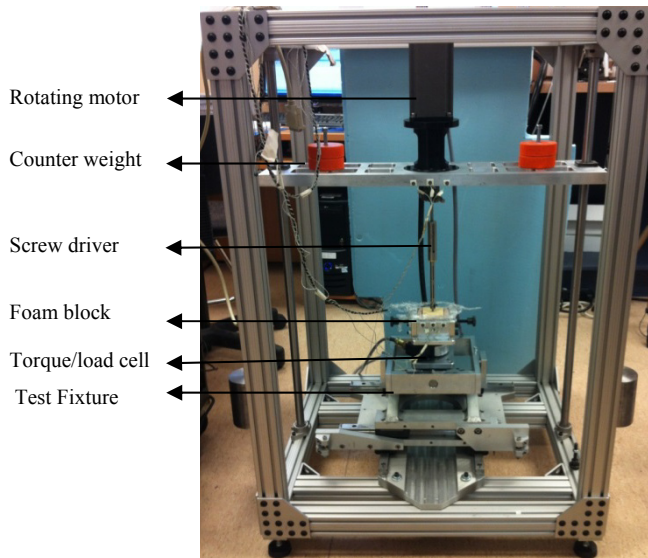

Figure 2. Custom-made torque measurement test bench.

E. Pullout test

After indentation and screw insertion in all specimens, the test fixture was transferred back into material testing machine for an axial pullout test. The test fixture was adjusted to ensure proper alignment of the screw longitudinal axis with pullout direction. The screw head was linked to the actuator using a shackle and bolt (Figure 3). A tensile displacement was applied to the screw head at a rate of 5 mm/min according to ASTM F 543-07 [14] until the screw released from the foam block. Load and displacement were recorded with a 2.5 kN load cell (model no, MTS Corp, Eden Prairie, MN) and analyzed for extracting the pullout force and stiffness. The stiffness was determined by calculating the slope of the most linear part of the load-displacement curve before the yield point in pullout test. Pullout force was defined as the peak load taken from load-displacement curve during the pullout test.



Figure 3. The test fixture placed in the material testing system for pullout test. Custom test fixture was the same as for indentation and torque measurement tests.

F. Statistical analysis

The data from all biomechanical tests were analyzed to investigate on potential relationships between insertion torque, indentation force and the strength of pedicle screw fixation. The peak insertion torque and the peak indentation force were related with pullout force and stiffness using simple linear regression. A P-value of less than 0.05 was taken as significant.

III. RESULTS

The results show that indentation forces, insertion torques, pullout force and stiffness significantly increase with density (Table 1). The statistical analysis using a linear regressions showed that there is a strong relationship between the indentation force and the pullout force ($R^2=0.98$) and stiffness ($R^2=0.97$) (Figure 4). Similarly, the insertion torque is significantly related to the pullout force ($R^2=0.99$) and stiffness ($R^2=0.96$). Significant relationships were also found between indentation force and torque ($R^2=0.99$) and between pullout force and stiffness ($R^2=0.96$). The P-value in all relationships are much smaller than 0.05.

Table1. Indentation forces, insertional torques, pullout forces and stiffness with corresponding standard errors

Density grade (g/cm ³)	Indentation force (N)	SE*	Insertional torque (N.m)	SE*	Pullout force (N)	SE*	Stiffness (N/mm)	SE*
10 (0.16)	175.79±20.52	9.18	0.78±0.11	0.05	271.16±114.74	51.32	1059.60±16.38	7.32
20 (0.32)	812.94±5.77	2.58	2.75±0.03	0.02	1507.68±64.19	28.71	1233.000±19.27	8.62
30 (0.48)	1888.25±107.52	48.08	5.71±0.22	0.10	3216.045±121.45	54.31	1980.400±64.79	28.97

*SE is the standard error

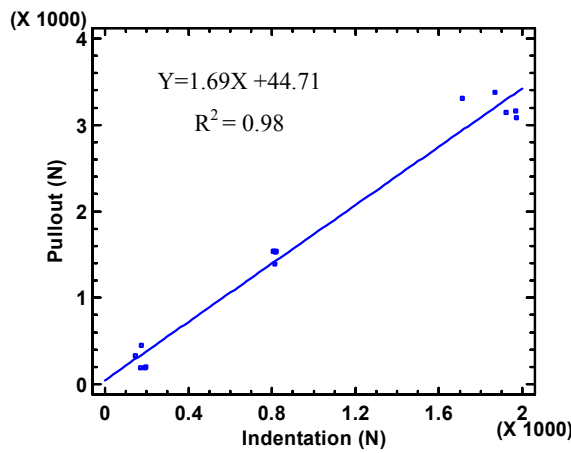

(a)

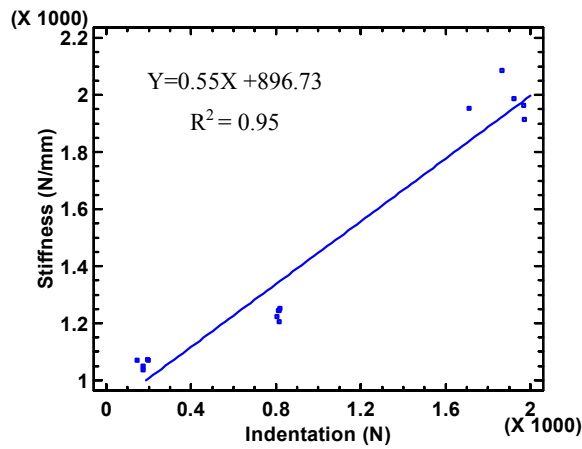

(b)

Figure 4. Relationships between Indentation and: (a) pullout; (b) stiffness

IV. DISCUSSION

The strength of pedicle screw fixation depends on several factors such as the screw design, the insertion technique, the bone density and their interactions. In this study the screw design and insertion technique were kept constant in order to take into account of only the bone surrogate properties and their effect on screw fixation strength through the measurement of the maximum probe indentation force and the maximum screw insertion torque. The insertion torque significantly increases with the bone surrogate density. A similar trend was observed for the indentation force, pullout force and stiffness. The relations found between the pullout force and the foam density is consistent with previous studies [15, 16] using polyurethane foam of grade 10 and grade 20 to measure axial pullout force for different screw types. Moreover, the present results indicate that the screw pullout force and stiffness can be estimated from measurements performed during screw insertion (i.e. indentation force and insertion torque). This was confirmed through significant relationships between indentation and torque and pullout force and stiffness. The outcomes of the present study should be confirmed by performing additional investigations on animal and/or human specimens.

REFERENCES

- [1] H. Pihlajamäki, P. Myllynen, and O. Böstman, "Complications of transpedicular lumbosacral fixation for non-traumatic disorders," *Journal of Bone & Joint Surgery, British Volume*, vol. 79, pp. 183-189, 1997.
- [2] S. I. Esses, B. L. Sachs, and V. Dreyzin, "Complications associated with the technique of pedicle screw fixation. A selected survey of ABS members," *Spine*, vol. 18, p. 2231, 1993.
- [3] B. Sanden, C. Olerud, M. Petren-Mallmin, C. Johansson, and S. Larsson, "The significance of radiolucent zones surrounding pedicle screws DEFINITION OF SCREW LOOSENING IN SPINAL INSTRUMENTATION," *Journal of Bone & Joint Surgery, British Volume*, vol. 86, pp. 457-461, 2004.
- [4] C. A. Dickman, R. G. Fessler, M. MacMillan, and R. W. Haid, "Transpedicular screw-rod fixation of the lumbar spine: operative technique and outcome in 104 cases," *Journal of neurosurgery*, vol. 77, pp. 860-870, 1992.

- [5] B. B. Abshire, R. F. McLain, A. Valdevit, and H. E. Kambic, "Characteristics of pullout failure in conical and cylindrical pedicle screws after full insertion and back-out," *The Spine Journal*, vol. 1, pp. 408-414, 2001.
- [6] T. K. Daftari, W. C. Horton, and W. C. Hutton, "Correlations between screw hole preparation, torque of insertion, and pullout strength for spinal screws," *Journal of spinal disorders*, vol. 7, p. 139, 1994.
- [7] M. Haidekker, R. Andresen, and H. Werner, "Relationship between structural parameters, bone mineral density and fracture load in lumbar vertebrae, based on high-resolution computed tomography, quantitative computed tomography and compression tests," *Osteoporosis international*, vol. 9, pp. 433-440, 1999.
- [8] B. Sandén, C. Olerud, S. Larsson, and Y. Robinson, "Insertion torque is not a good predictor of pedicle screw loosening after spinal instrumentation: a prospective study in 8 patients," *Patient safety in surgery*, vol. 4, pp. 1-5, 2010.
- [9] J. Lee, J. Park, and Y. Shin, "The insertional torque of a pedicle screw has a positive correlation with bone mineral density in posterior lumbar pedicle screw fixation," *Journal of Bone and Joint Surgery-British Volume*, vol. 94, p. 93, 2012.
- [10] A. W. L. Kwok, J. A. Finkelstein, T. Woodside, T. C. Hearn, and R. W. Hu, "Insertional torque and pull-out strengths of conical and cylindrical pedicle screws in cadaveric bone," *Spine*, vol. 21, p. 2429, 1996.
- [11] S. Teoh and C. Chui, "Bone material properties and fracture analysis: Needle insertion for spinal surgery," *Journal of the mechanical behavior of biomedical materials*, vol. 1, pp. 115-139, 2008.
- [12] P. Zysset, "Indentation of bone tissue: a short review," *Osteoporosis international*, vol. 20, pp. 1049-1055, 2009.
- [13] ASTM, "F 1839-01. Standard specification for rigid polyurethane foam for use as a standard material for testing orthopedic devices and instruments," 2007.
- [14] ASTM, "F 543 - 07. Standard Specification and Test methods for Metallic Medical Bone Screws," 2007.
- [15] P. S. D. Patel, D. E. T. Shepherd, and D. W. L. Hukins, "The effect of screw insertion angle and thread type on the pullout strength of bone screws in normal and osteoporotic cancellous bone models," *Medical engineering & physics*, vol. 32, pp. 822-828, 2010.
- [16] M. H. Krenn, W. P. Piotrowski, R. Penzkofer, and P. Augat, "Influence of thread design on pedicle screw fixation," 2008.

APPENDIX II

CONFERENCE ARTICLE 2: BIOMECHANICAL EVALUATION OF PEDICLE SCREW LOOSENING MECHANISM USING SYNTHETIC BONE SURROGATE OF VARIOUS DENSITIES

In proceeding of 36th Annual International Conference of the IEEE Engineering in Medicine and Biology Society (EMBC'14) 26-30 August 2014, Chicago, IL, USA

H.N. Mehmanparast^{a,c}, JM. Mac-Thiong^b, and Y. Petit^{a,c}

^aMechanical Engineering Department, Ecole de Technologie Superieure, Montreal, QC, Canada, H3C 1K3.

^bDivision of Orthopedic Surgery, University of Montreal, Montreal, QC, Canada, H3T 1C5.

^cResearch Center, Sacré-Cœur Hospital, Montreal, QC, Canada, H4J 1C5.

Corresponding author: hedayeh.mehmanparast-nodehi.1@ens.etsmtl.ca

Abstract—Pedicle screw fixation is a well-established procedure for various spinal disorders. However, pedicle screws failures are still reported. Therefore, there is a need for a greater understanding of the pedicle screw failure mechanism. This experimental study investigates the biomechanical stability of pedicle screws using a synthetic bone surrogate with a special focus on the screw loosening mechanism. Pedicle screws have been inserted in thirty six polyurethane foam blocks of three different densities. In half of the specimens from each density group, pedicle screws were submitted to cyclic bending (toggling) before pullout. The rest of specimens were solely loaded in axial pullout. The peak pullout force and stiffness were determined from load-displacement curve of each specimen. Statistical analyses were performed to investigate on the effect of toggling and bone surrogate density on the pedicle screw's pullout force. The results suggest that the pullout force and stiffness were significantly affected by toggling and density. Higher pullout forces resulted from higher grades of density. The proposed method allowed investigating the pedicle screw loosening mechanism. However, conducting further experimental tests on animal or cadaveric vertebrae are needed to confirm these findings.

I. INTRODUCTION/PROBLEMATIC

Pedicle screw fixation is widely used for different spinal disorders since it allows to reduce the length of fused segments and provides high fixation stability [1, 2]. Fixation failure, however, can lead to loss of fixation and severe complications. The rate of pedicle screw failure is reported to be 0.8% to 17% [3-5].

There are numerous factors affecting the fixation strength including the vertebral body bone density, anatomy of pedicles, screw design and the screw insertion technique [6-10]. Modification of the screw design can improve the incidence of implant failure, yet the reasons for such failure have not been elucidated yet [5, 11, 12]. Biomechanical studies commonly use the axial pullout test to assess fixation strength of pedicle screws by measuring the peak pullout force from synthetic or cadaveric bone materials [13]. However, there is no agreement in results of such studies in the literature [7, 14, 15]. This could be due to the fact that the screw failure occurs in other condition than axial pullout in vivo. Therefore, there is a need to modify the biomechanical test method to examine the pedicle screw fixation strength.

To the author's knowledge, no previous study has compared the pedicle screw pullout forces with and without cyclic bending (toggling) prior to pullout in different bone surrogate densities. Therefore, this study was designed to investigate the screw loosening mechanism and its possible effect on the pullout force.

II. MATERIAL AND METHODS

A. Specimen preparation

This study was conducted on thirty six solid rigid polyurethane foam blocks (5cm x 5cm x 4cm; Sawbones, Pacific Research Laboratories, Vashon, WA, USA). Foam blocks of three different density grades (twelve blocks of each grade) [16] were used to avoid inherent variability of cadaveric bone including the bone quality and geometry: grade 10 (0.16 g/cm³), grade 20 (0.32 g/cm³) and grade 30 (0.48 g/cm³). Pedicle screws of 5 mm x 35 mm (DePuy Spine, Inc., Raynham, MA, USA) were entirely inserted in the pre-drilled foam blocks at a speed of 3r/min (Figure 1).



Figure 1. Pedicle screw has been fully inserted into polyurethane foam specimens

B. Biomechanical testing

The foam blocks were embedded into an aluminum frame using polyester resin. Biomechanical testing was conducted on two specimen groups for each density grade. Six specimens were taken for toggling prior to pullout as group I and the other six specimens were used for standard pullout test as the control group II. For the toggling test, the specimens were secured into material testing system (MTS 858, Bionix, Eden Prairie, MN, USA) using custom jigs (Figure 2).

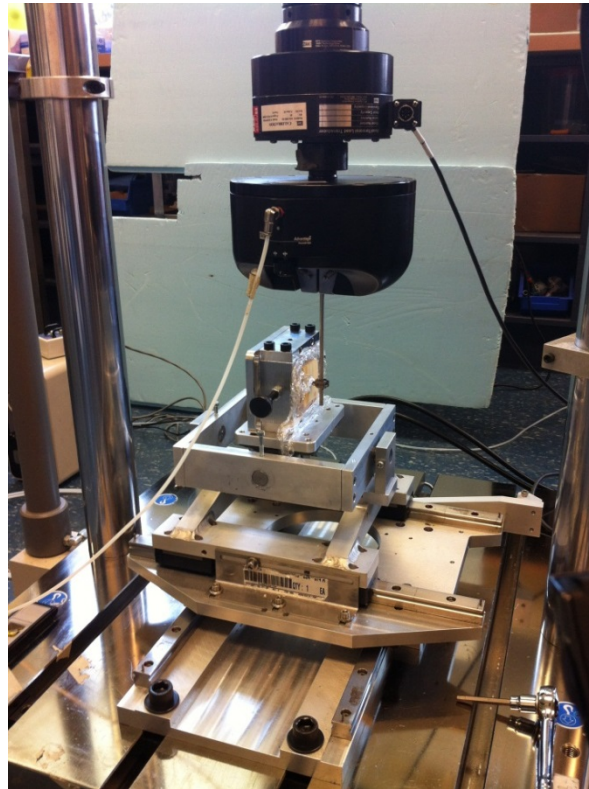

Figure 2. Test fixture and load frame for toggling test.

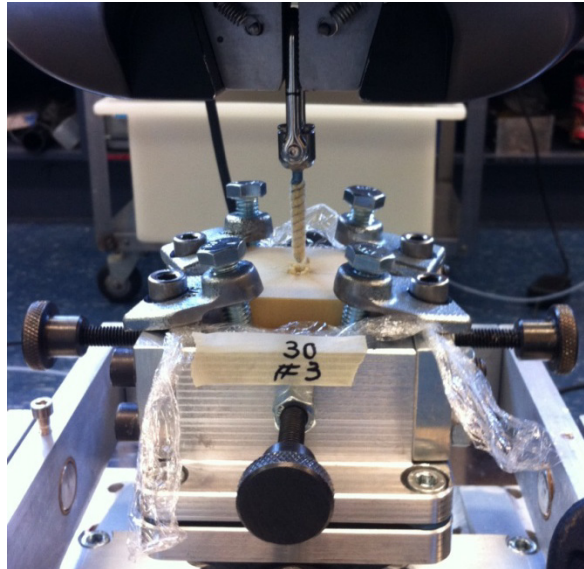

Figure 3. Pedicle screw pullout test.

The screw heads were coupled with a rod and bolt provided by the screw manufacturer. The cyclic bending load was applied through the rod perpendicular to the longitudinal axis of the screw with maximum displacement of ± 1 mm at a frequency of 3 Hz for 5000 cycles while the force and displacement were monitored. This displacement magnitude was chosen to provide a nondestructive physiologic load comparable to those generated during normal walking [17]. According to preliminary tests, no damage such as crack or breakage was observed on the foam materials of various densities.

Subsequently, toggled and non-toggled specimens were placed and oriented in a custom fixture for the axial pullout test. A tensile displacement was applied at constant rate of 5 mm/min until the screw released from the test block (Figure 3) according to standard test method for medical bone screws [13]. Axial force, displacement and time data were monitored.

C. Statistical analysis

To characterize the pedicle screw fixation strength, two dependent variables were evaluated: pullout force and stiffness. The pullout force was defined as the maximum force during axial pullout of the screw and the stiffness was calculated as the slope of load-displacement curve before complete pull-out. These parameters were used to assess the effect of independent variables (density and loading condition) and their interactions using multiple factorial analyses of variance (ANOVA). Pareto

charts were used to compare the relative importance of the main effects and interaction of these parameters on the studied responses (pullout force and stiffness). Those effects exceeding the reference line in the Pareto chart are related to statistically significant parameters at 95% confidence level. Wilcoxon test was performed to determine the significant difference between toggled and non-toggled data for pullout force and stiffness.

III. RESULTS

Figure 4 shows the pareto charts of standardized effect for pullout force and stiffness. It is observed that pedicle screw's pullout force and stiffness are significantly affected by loading condition (toggling) and bone surrogate density. Increasing the density significantly increases the pullout force whereas screw toggling significantly decreases the pullout force.

Detailed evaluation of direct effects of foam density grades on pullout force and stiffness with respect to toggling method used is illustrated in Figure 5. Significant differences were observed for the stiffness between toggled and non-toggled screws for density grade 10 ($p=0.03$), grade 20 ($p=0.03$) and grade 30 ($p=0.03$). Similarly, the difference from toggled and non-toggled pullout force was found as significant for grade 20 ($p=0.01$).

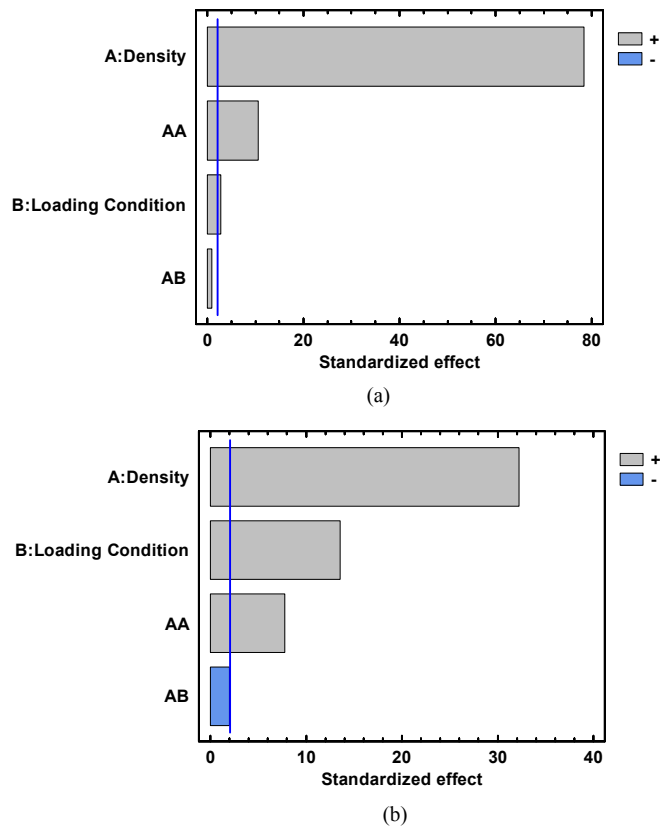
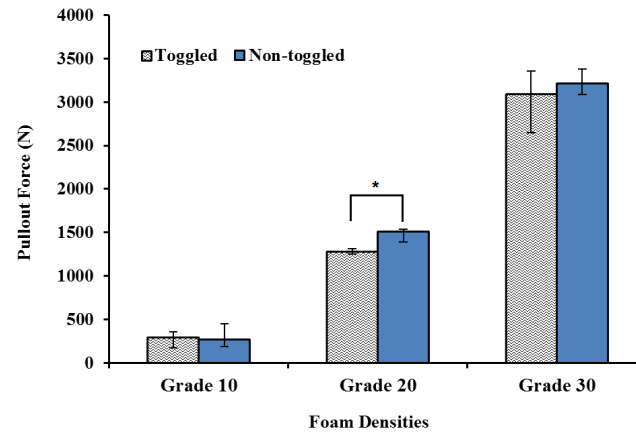
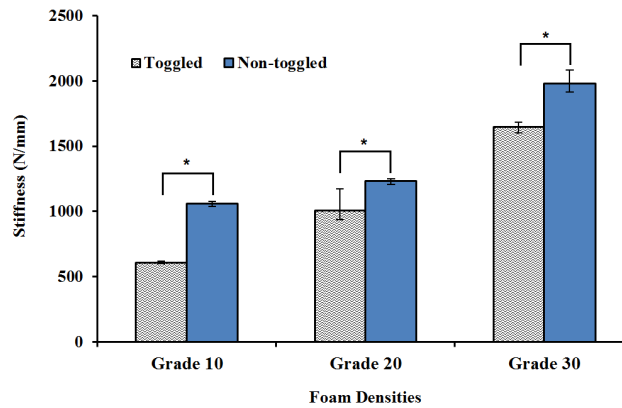

Figure 4. Pareto chart of the standardized effect on: (a) Pullout force; (b) stiffness. Blue lines define the thresholds for significant effects. ($p < 0.05$).



(a)



(b)

Figure 5. Comparison between cycled and non-cycled tests at various densities: (a) pullout strength and (b) stiffness. * Significant differences.

IV. DISCUSSION

The in vitro test method to evaluate the pedicle screw fixation strength is currently the standard axial pullout test. However, it does not mimic the realistic situation of screw failure secondary to loosening from individual's daily activities. This study proposed a new method for testing the screw fixation strength by toggling before pullout test and compared with the conventional pullout test. The measured parameters in this study i.e. the pullout force and stiffness allowed evaluating the strength of screw by measuring the maximum load at failure point and the rigidity of screw that shows the resistance to deformation. The statistical analysis shows a significant effect of toggling on the pullout force, supporting the use of this new method to better assess screw fixation strength.

Lotz et al. [17] evaluated the screw pullout forces with and without toggling on osteoporotic cadavers. They did not find statistical difference between the two groups. It is, however, notable that their study used pedicle screws with cement augmentation and did not investigate for the stiffness [17]. To the author's knowledge, no other study has compared the pullout forces of toggled and non-toggled pedicle screws.

The direct interpretation of our results for clinical application is limited since the bone inhomogeneity and the effect of pedicle geometry are not considered in the bone surrogates used this study. Therefore, further investigations are needed to be performed on animal or cadaveric vertebrae to confirm the results.

V. CONCLUSION

A novel method was implemented to study pedicle screw loosening mechanism. It allows improving our understanding of the failure mechanism that happens clinically. Toggling is more likely to affect pedicle screw stiffness than pullout force. However, further experimental tests are needed to confirm these findings.

ACKNOWLEDGMENT

This research is supported by Natural Sciences and Engineering Council (NSERC) and the Canada Research Chair in Engineering for Innovations in Spinal Trauma.

REFERENCES

- [1] P. Sanderson, R. D. Fraser, D. J. Hall, C. M. J. Cain, O. L. Osti, and G. Potter, "Short segment fixation of thoracolumbar burst fractures without fusion," *European Spine Journal*, vol. 8, pp. 495-500, 1999.
- [2] A. R. Vaccaro, D. H. Kim, D. S. Brodke, M. Harris, J. Chapman, T. Schildhauer, et al., "Diagnosis and management of thoracolumbar spine fractures," *The Journal of Bone & Joint Surgery*, vol. 85, pp. 2456-2470, 2003.
- [3] C. A. Dickman, R. G. Fessler, M. MacMillan, and R. W. Haid, "Transpedicular screw-rod fixation of the lumbar spine: operative technique and outcome in 104 cases," *Journal of neurosurgery*, vol. 77, pp. 860-870, 1992.

- [4] S. I. Esses, B. L. Sachs, and V. Dreyzin, "Complications associated with the technique of pedicle screw fixation. A selected survey of ABS members," *Spine*, vol. 18, p. 2231, 1993.
- [5] P. Katonis, J. Christoforakis, A. C. Aligizakis, C. Papadopoulos, G. Sapakas, and A. Hadjipavlou, "Complications and problems related to pedicle screw fixation of the spine," *Clinical orthopaedics and related research*, vol. 411, pp. 86-94, 2003.
- [6] K. Okuyama, K. Sato, E. Abe, H. Inaba, Y. Shimada, and H. Murai, "Stability of transpedicle screwing for the osteoporotic spine: an in vitro study of the mechanical stability," *Spine*, vol. 18, pp. 2240-2245, 1993.
- [7] T. Hirano, K. Hasegawa, H. E. Takahashi, S. Uchiyama, T. Hara, T. Washio, et al., "Structural characteristics of the pedicle and its role in screw stability," *Spine*, vol. 22, pp. 2504-2510, 1997.
- [8] M. H. Krenn, W. P. Piotrowski, R. Penzkofer, and P. Augat, "Influence of thread design on pedicle screw fixation," 2008.
- [9] D. C. GEORGE, M. H. KRAG, C. C. JOHNSON, M. E. VAN HAL, L. D. HAUGH, and L. J. GROBLER, "Hole preparation techniques for transpedicle screws: Effect on pull-out strength from human cadaveric vertebrae," *Spine*, vol. 16, pp. 181-184, 1991.
- [10] M. Pfeiffer, L. G. Gilbertson, V. K. Goel, P. Griss, J. C. Keller, T. C. Ryken, et al., "Effect of specimen fixation method on pullout tests of pedicle screws," *Spine*, vol. 21, pp. 1037-1044, 1996.
- [11] J. E. Lonstein, F. Denis, J. H. Perra, M. R. Pinto, M. D. Smith, and R. B. Winter, "Complications Associated with Pedicle Screws*," *The Journal of Bone & Joint Surgery*, vol. 81, pp. 1519-28, 1999.
- [12] H. Pihlajamäki, P. Myllynen, and O. Böstman, "Complications of transpedicular lumbosacral fixation for non-traumatic disorders," *Journal of Bone & Joint Surgery, British Volume*, vol. 79, pp. 183-189, 1997.
- [13] ASTM, "F 543 - 07. Standard Specification and Test methods for Metallic Medical Bone Screws," 2007.
- [14] J. Chapman, R. Harrington, K. Lee, P. Anderson, A. Tencer, and D. Kowalski, "Factors affecting the pullout strength of cancellous bone screws," *Journal of biomechanical engineering*, vol. 118, p. 391, 1996.
- [15] T. K. Daftari, W. C. Horton, and W. C. Hutton, "Correlations between screw hole preparation, torque of insertion, and pullout strength for spinal screws," *Journal of spinal disorders*, vol. 7, p. 139, 1994.
- [16] ASTM, "F 1839-01. Standard specification for rigid polyurethane foam for use as a standard material for testing orthopedic devices and instruments," 2007.

[17] J. C. Lotz, S. S. Hu, D. F. M. Chiu, M. Yu, O. Colliou, and R. D. Poser, "Carbonated apatite cement augmentation of pedicle screw fixation in the lumbar spine," *Spine*, vol. 22, p. 2716, 1997.

APPENDIX III

CONFERENCE ARTICLE 3: IN VITRO EVALUATION OF PEDICLE SCREW LOOSENING MECHANISM: A PRELIMINARY STUDY ON ANIMAL MODEL

In proceeding of 10th Meeting of the International Research Society of Spinal Deformities (IRSSD 2014)
Sapporo, Japan, June 29 to July 2 2014

H.N. Mehmanparast^{a,c}, JM. Mac-Thiong^b, and Y. Petit^{a,c}

^aMechanical Engineering Department, Ecole de Technologie Superieure, Montreal, QC, Canada, H3C 1K3.

^bDivision of Orthopedic Surgery, University of Montreal, Montreal, QC, Canada, H3T 1C5.

^cResearch Center, Sacré-Cœur Hospital, Montreal, QC, Canada, H4J 1C5.

Corresponding author: hedayeh.mehmanparast-nodehi.1@ens.etsmtl.ca

Objective-Pedicle screw fixation is a well-established procedure for various spinal disorders. However, pedicle screws failures are still reported. Therefore, there is a need for a better understanding of the pedicle screw failure mechanism. This study investigates the biomechanical stability of pedicle screws on animal vertebrae with a special focus on the screw loosening mechanism.

Materials and methods-Eighteen vertebrae were harvested from the lumbar section of six porcine spines ranged from L1 to L3. All vertebrae were instrumented on both pedicles using pedicle screws. Quantitative CT scans were used before instrumentation in order to assess the bone density of each vertebra. Cyclic bending (toggling) load of ± 1 mm displacement at 3 Hz for 5000 cycles were assigned in two directions: craniocaudal (CC) and transverse (TR) toggling. Twelve instrumented pedicles were selected for CC toggling, twelve pedicles for TR toggling and twelve pedicles were no toggling (NT). All toggled and non-toggled screws were then pulled out at a displacement speed of 5 mm/min in longitudinal direction. The peak pullout force and stiffness were computed from the load-displacement curves. Analyses of variance (ANOVA) with 95% confidence level were performed to investigate the effects of toggling methods and vertebral levels on the pullout force and stiffness.

Results-The results suggest that, regardless to the toggling method used, the pullout force significantly varies between vertebral levels. The highest pullout forces were observed at L1 (1906 ± 225 N for CC, 1917 ± 151 N for TR and 1998 ± 108 N for NT). The lowest pullout forces were detected at L3 (1646 ± 110 N for CC, 1868 ± 120 N for TR and 1875 ± 178 N for NT). Pedicle screw's pullout force and stiffness were significantly affected by toggling method ($p = 0.001$, $p << 0.05$) and vertebral level ($p = 0.001$, $p << 0.05$) respectively based on ANOVA. There was a significant difference in stiffness between CC and TR ($p = 0.02$), CC and NT ($p << 0.05$), and TR and NT pedicle screws ($p = 0.002$).

APPENDIX IV

JOURNAL ARTICLE1: COMPARISON OF PEDICLE SCREW LOOSENING MECHANISMS AND THEIR EFFECT ON FIXATION STRENGTH

Article submitted to *Journal of Biomechanical Engineering*

H.N. Mehmanparast^{a,c}, JM. Mac-Thiong^b, and Y. Petit^{a,c}

^aMechanical Engineering Department, Ecole de Technologie Supérieure, Montreal, QC, Canada, H3C 1K3.

^bDivision of Orthopedic Surgery, University of Montreal, Montreal, QC, Canada, H3T 1C5.

^cResearch Center, Sacré-Cœur Hospital, Montreal, QC, Canada, H4J 1C5.

Corresponding author: yvan.petit@etsmtl.ca

ABSTRACT

Screw loosening is a common complication in spinal fixation using pedicle screws which may lead to loss of correction and revision surgery. The mechanisms of pedicle screw loosening are not well understood. The purpose of this study was to compare the pedicle screw pullout force and stiffness subsequent or not to multidirectional cyclic bending load (toggling). Pedicle screws inserted into porcine lumbar vertebrae were undergone toggling in cranio-caudal (CC), medio-lateral (ML) directions and no toggling (NT) before pullout. This study suggests that toggling and in particular CC toggling should be included in biomechanical evaluation of pedicle screw fixation strength.

Keywords- Biomechanics, Spine, Pedicle screw, Loosening, Fixation strength, Pullout force, stiffness

INTRODUCTION

Pedicle screw fixation is commonly used for the surgical treatment of spinal fractures, deformities and degenerative changes [1-3]. Compared to other vertebral anchors, it increases fixation stability, promoting spinal fusion and healing. However, there are complications associated with this widespread fixation technique. Fixation failure rate due to screw loosening range from 0.8% to 17% and can rise in osteoporotic spines for which the strength of fixation with pedicle screws decreases along with lower bone density [4-7]. Screw augmentation with bone cement or modification of pedicle screw design may decrease the loosening and enhance the pedicle screw fixation [8-11]. However, thorough understanding of screw loosening mechanisms is the key to the success of fixation, helping spine surgeons decide on the optimal fixation methods.

Although it is not likely the unique mode of pedicle screw failure seen clinically, biomechanical experiments often use the axial pullout test to estimate the pedicle screw fixation strength in cadaveric and animal vertebrae [12-20] and in synthetic bone surrogates [21-24]. Number of studies [25-32] applied cyclic bending loads on pedicle screws before pull out, assuming that loosening at screw-bone interface is a relevant mode of failure. Nevertheless, the advantage of using such method rather than conventional axial pullout test remains unclear. Although aforementioned studies often use cranio-caudal cyclic loading, repeated loading in other directions such as mediolateral may also cause screw loosening. Furthermore, the effect of vertebral levels on screw fixation strength or loosening mechanism is not well understood.

The objective of this study was to compare the effect of screw loosening from cyclic loading (toggling) in cranio-caudal (CC) and medio-lateral (ML) on pedicle screw pullout force and stiffness in porcine lumbar vertebrae. It was hypothesized that toggling significantly loosens the screw and decreases the pullout force and fixation stiffness.

MATERIALS AND METHODS

Study Design

As shown in Table 1, a full factorial design of experiment with two factors at three levels (3^2) was used to assess the effect of toggling mode and vertebral level on pedicle screw fixation strength measured through pullout force and stiffness. Experimental tests were repeated five times. A total of 54 tests were performed to complete the experimental plan.

Specimen Preparation

Twenty seven vertebrae ranging L1 to L3 were harvested from nine mature pigs (average 24 weeks old). Each vertebra was isolated, cleaned from surrounding soft tissues and intervertebral discs. Porcine specimens are considered to be an adequate model for biomechanical investigations of the spine since they present low variation in bone quality and are more available than human cadaveric spine [33-36]. Computed tomographic (CT) images of the specimens along with 3 hydroxyapatite calibration phantoms were obtained using a Lightspeed VCT scanner (GE Medical System, Milwaukee, WI). The CT images were first used to confirm that no bone fracture or pathology was present. For each vertebra, the apparent density of trabecular bone (BMD) of the vertebral body and pedicles was estimated from a linear relationship between the Hounsfield unit and the density of calibration phantoms as in [38]. Specimens with pedicle wall breach or fracture were excluded from

the study. The pedicle width (Ped.W), height (Ped.H) and area (Ped.A) were also measured from the CT images. The specimens were stored at -24°C and thawed 12 hours before screw insertion and biomechanical testing. To provide a rigid fixation for biomechanical testing, the vertebral body was embedded into an aluminum frame using polyester resin leaving the pedicles accessible for instrumentation.

The pedicle cortex was opened using a pedicle awl and the pilot hole was created using a custom-made probe of smaller diameter (3mm) than the pedicle screw major diameter. Polyaxial pedicle screws of 5.0 x 35 mm (DePuy Spine, Inc., Raynham, MA, USA) were inserted in each pedicle at a speed of 3 r/min until the entire screw threads were engaged in the trabecular bone. The pedicle screw size and design was held constant for all specimens. All the pedicle screws were inserted into the vertebrae using straight-forward insertion technique.

Biomechanical Testing

Instrumented vertebrae were assigned to one of three toggling modes; cranio-caudal toggling (CC), medio-lateral toggling (ML) and no toggling (NT). Pedicles of each vertebra were randomly assigned to one toggling mode to allow performing a paired test comparing one toggling mode to another within the same vertebra. Toggling tests were conducted with a material testing system (858 Bionix, MTS Systems Corporation, Eden Prairie, MN) using a custom-made fixture as shown in Fig. 1. The screw heads were coupled with a rod provided by the implant manufacturer. The fixture allowed perpendicular alignment of the rod and the loading axis with the screw head. For the CC tests, the cyclic bending load was applied in the sagittal plane of the vertebra with a maximum displacement of $\pm 1\text{mm}$ at 3 Hz for 5000 cycles and the force and displacement were recorded. For ML tests, the cyclic load was conducted on the coupled rod in the transverse plane with the same procedure as described for CC tests. According to preliminary tests, the selected number of cycles was enough to loosen the pedicle screws while they are still engaged in the vertebrae before the pullout test.

Subsequently, each specimen, toggled or non-toggled, was reoriented in a custom fixture allowing coaxial alignment in translation and rotation of the pedicle screw with the loading axis of the material testing system (858 Bionix, MTS Systems Corporation, Eden Prairie, MN) for axial pullout test as shown in Fig. 2. A tensile load was applied at a constant rate of 5 mm/min following the same axis as the pedicle screw until the screw released from the vertebra according to standard test method for medical bone screws [39]. Axial force and displacement were recorded at a frequency of 100 Hz

during pullout. The pullout force and stiffness were computed from the load-displacement curves. The pullout force was defined as the maximum force the bone-screw interface resists before failure (plastic deformation or negative deflection on the curve) and the stiffness was defined as the slope of the linear part of the curve (elastic region) before the yield point.

The effects of independent variables (toggling mode and vertebral level) and their interactions on fixation strength were assessed using multiple factorial analyses of variance (ANOVA) with significance level at $p < 0.05$. Wilcoxon paired tests were performed to investigate on significantly different pullout force and stiffness between CC, ML and NT toggling. Pearson correlations were used to determine the relationship between the pullout force and the BMD and pedicle geometry.

RESULTS

Complete pullout of the pedicle screws was achieved in 50 pedicles with failure at the screw-bone interface. Four pedicles fractured at the pedicle-body junction with the screw remaining intact inside the detached pedicle and were excluded from the analysis. Figure 3 shows Pareto charts comparing the main effect of toggling modes (B) and vertebral levels (A) and their interaction (AB) on the screw pullout force and stiffness. One could observe that pedicle screw pullout force and stiffness are significantly affected by toggling mode and vertebral level. On one hand, changing the toggling mode from CC to ML and NT significantly increases the pullout force whereas changing vertebral level caudally from L1 to L2 and L3 significantly decreases the pullout force. On the other hand, the same change in toggling mode and vertebral level significantly increase the stiffness. The stiffness is also statistically affected by the interaction between the toggling mode and the vertebral level (AB). Finally, the quadratic effect of vertebral level (AA) was non-significant for the pullout force and stiffness suggesting linear variations with the vertebral level.

The 2D contour plots shown in Fig. 4 (a) reveal that the lowest pullout force was observed at L3 after CC toggling. However, with the same toggling mode (CC), the lowest stiffness was observed at L1 as shown in Fig. 4 (b). In other words, changing the vertebral level from L1 to L3 decreased the pullout force and increased the stiffness.

As shown in Fig. 5 (a), the pullout force was 1891 ± 255 (N) for CC toggling compared to 2003 ± 196 (N) for ML toggling and 2010 ± 209 (N) for NT. The pullout force after CC toggling was significantly lower than after NT ($P = 0.02$) and ML ($P = 0.03$) toggling but no difference was found

between ML and NT. As depicted in Fig. 5 (b), the stiffness was 1713 ± 47 (N/mm), 1775 ± 35 (N/mm) and 1859 ± 97 (N/mm), for CC, ML and NT modes respectively. Significant difference was observed between all toggling modes ($P < 0.001$).

Pullout force showed no significant difference between L1 and L3 ($P = 0.05$), L2 and L3 ($P > 0.05$) and between L1 and L2 ($P > 0.05$). Nevertheless, the stiffness was significantly different between L1 and L3 ($P = 0.002$) even though no difference was observed between L2 and L3 ($P = 0.05$) and between L1 and L2 ($P > 0.05$). Table 2 summarizes the geometrical measurements performed at all vertebral levels. No significant difference was found for pedicle width (Ped.W), pedicle height (Ped.H) and BMD between all vertebral levels. However, pedicle area (Ped.A) was significantly different between L1 and L3 ($P < 0.001$).

Since CC toggling affected the most pedicle screw pullout force and stiffness, significant inverse correlation was established between Ped.A and the pullout force ($r = -0.63$; $P = 0.009$) and positive correlation between Ped.A and the stiffness ($r = 0.70$; $P = 0.003$) for this toggling group. Significant correlation was observed between BMD and the pullout force ($r = 0.88$; $P < 0.0001$) and inverse correlation between BMD and the stiffness ($r = -0.60$; $P = 0.02$) after CC toggling.

DISCUSSION

This study is the first to evaluate the pedicle screw loosening mechanisms in three toggling modes (CC, ML and NT), and to document their relative effect on pullout force and stiffness with respect to vertebral levels. Although several studies report in the literature cycling pullout tests for screw fixation assessment [25-29], none has compared the effect of multidirectional loading on the pedicle screw fixation strength.

This study confirmed the hypothesis suggesting that toggling can significantly reduce pedicle screw pullout force and stiffness regardless of the performed mode of toggling. This cyclic transverse load can develop compressive stress along the screw-bone interface, and lead to loss of fixation and pullout [27, 30-32]. The analysis of variance suggests that toggling affects more the stiffness than the pullout force relative to vertebral level. This may be caused by the screw behaviour under toggling being affected by the pedicle geometry [18, 19, 30]. The latter is supported by the significant correlation of the pedicle cross-section area and the stiffness and an inverse correlation with the pullout force in the current study. Pullout force, however, is more dependent to the BMD of pedicles.

The present study also found a significant relationship ($P < 0.001$, $r > 0.76$) between the pullout force and the BMD of the pedicles regardless of toggling mode. Moreover, a significantly lower pullout force and stiffness was found after cranio-caudal toggling than after medio-lateral ($P = 0.03$, $P < 0.0001$) or no toggling ($P = 0.02$, $P < 0.0001$). Reference [29] shows no significant difference between the pullout force after toggling and no toggling on human cadaveric vertebrae. This discrepancy may be in part due to variation in bone quality [15, 20, 24] and/or pedicle geometry [18, 19, 27, 30] of specimen groups which are being compared in different species.

This study also revealed that the screw pullout force and stiffness were significantly affected by the vertebral level regardless of the toggling mode. A decrease in pullout force and an increase in stiffness was observed from L1 to L3. These may be explained in part by significantly different pedicle cross-sectional area (Ped.A) for each level. A strong inverse correlation was found between the Ped.A ($P < 0.05$) and the pullout force under CC toggling, reflecting the stronger fixation when the pedicle screw fills a greater proportion of the pedicle area. Other studies [18, 30] have shown similar correlation between pedicle size and screw stiffness and pullout force obtained after cyclic loading in human cadaveric lumbar vertebrae.

The small number of samples used is a limitation of this study. Nevertheless, a full factorial design of experiment with five repetitions allowed the observation of significant effects on pedicle screw fixation strength. Also, specimens with pedicle-body junction fracture were excluded from the analysis to avoid affecting the outcome measures from loosen screws. Furthermore, adequate screw placement was ensured by using a custom-designed fixture allowing to adjust the screw insertion angle and the pedicle trajectory. This biomechanical study was performed on porcine vertebrae which have about twice greater BMD than human vertebrae [36]. Thus, care should be taken not to extrapolate the findings of present study to weak osteoporotic vertebrae and additional experiments would be required. However, since the pedicle anatomy of porcine vertebrae, having a greater pedicle height than width, are comparable to human L3 and cephalad vertebrae [37], the findings of this study would not affect the conclusion for human vertebrae.

CONCLUSION

This study is the first to quantify the effect of toggling and vertebral level on the pedicle screw pullout force and stiffness. Cranio-caudal toggling significantly affect the pullout force and the screw stiffness, which supports its systematic use to better assess screw fixation strength. Pedicle screw

fixation strength is also affected by vertebral level. These results allow improving the understanding of pedicle screw failure mechanisms which can lead to improvements in pedicle screw designs and decision of surgeons for using the most appropriate fixation technique. Further experimental tests are planned on osteoporotic human vertebrae to confirm these findings.

ACKNOWLEDGMENT

Pedicle screws and surgical instrumentation for specimen preparation were provided by DePuy Spine, Inc. (Raynham, MA).

FUNDING

This research was funded in part by Canadian Foundation for Innovation (CFI), Natural Sciences and Engineering Council of Canada (NSERC) and the Canada Research Chair in Engineering for Innovations in Spinal Trauma.

NOMENCLATURE

<i>CT</i>	computed tomography
<i>CC</i>	cranio-caudal toggling
<i>ML</i>	medio-lateral toggling
<i>NT</i>	no toggling
Ped. A	pedicle cross sectional area
Ped.H	pedicle height
Ped.W	pedicle width
ANOVA	analysis of variance
BMD	bone mineral density
<i>r</i>	Pearson's correlation coefficient
<i>P</i>	P-value

REFERENCES

- [1] Vaccaro, A.R., et al., 2003, "Diagnosis and management of thoracolumbar spine fractures," *The Journal of Bone & Joint Surgery*, **85**(12), pp. 2456-2470.
- [2] Sanderson, P., et al., 1999, "Short segment fixation of thoracolumbar burst fractures without fusion," *European Spine Journal*, **8**(6), pp. 495-500. DOI: 10.1007/s005860050212
- [3] Cheung, W.Y., L.G. Lenke, and K.D. Luk, 2010, "Prediction of scoliosis correction with thoracic segmental pedicle screw constructs using fulcrum bending radiographs," *Spine*, **35**(5), pp. 557-561. DOI: 10.1097/BRS.0b013e3181b9cfa9
- [4] Dickman, C.A., et al., 1992, "Transpedicular screw-rod fixation of the lumbar spine: operative technique and outcome in 104 cases," *Journal of neurosurgery*, **77**(6), pp. 860-870. DOI: 10.3171/jns.1992.77.6.0860
- [5] Esses, S.I., B.L. Sachs, and V. Dreyzin, 1993, "Complications associated with the technique of pedicle screw fixation. A selected survey of ABS members," *Spine*, **18**(15), pp. 2231. DOI: 10.1097/00007632-199311000-00015
- [6] Sanden, B., et al., 2004, "The significance of radiolucent zones surrounding pedicle screws, definition of screw loosening in spinal instrumentation," *Journal of Bone & Joint Surgery, British Volume*, **86**(3), pp. 457-461. DOI: 10.1302/0301-620X.86B3.14323
- [7] Katonis, P., et al., 2003, "Complications and problems related to pedicle screw fixation of the spine," *Clinical orthopaedics and related research*, **411**, pp. 86-94. DOI: 10.1097/01.blo.0000068761.86536.1d
- [8] Sandén, B., et al., 2002, "Hydroxyapatite coating improves fixation of pedicle screws A CLINICAL STUDY," *Journal of Bone & Joint Surgery, British Volume*, **84**(3), pp. 387-391. DOI: 10.1302/0301-620X.84B3.12388
- [9] Kwok, A.W.L., et al., 1996, "Insertional torque and pull-out strengths of conical and cylindrical pedicle screws in cadaveric bone," *Spine*, **21**(21), pp. 2429. DOI: 10.1097/00007632-199611010-00004
- [10] Cook, S.D., et al., 2004, "Biomechanical study of pedicle screw fixation in severely osteoporotic bone," *The Spine Journal*, **4**(4), pp. 402-408. DOI: 10.1016/j.spinee.2003.11.010
- [11] Cook, S.D., et al., 2001, "Lumbosacral fixation using expandable pedicle screws: an alternative in reoperation and osteoporosis," *The Spine Journal*, **1**(2), pp. 109-114. DOI: 10.1016/S1529-9430(01)00020-1
- [12] Mehta, H., et al., 2011, "Biomechanical analysis of pedicle screw thread differential design in an osteoporotic cadaver model," *Clinical Biomechanics*, DOI: 10.1016/j.clinbiomech.2011.10.004

- [13] Pfeiffer, M., et al., 1996, "Effect of specimen fixation method on pullout tests of pedicle screws," *Spine*, **21**(9), pp. 1037-1044. DOI: 10.1097/00007632-199605010-00009
- [14] Abshire, B.B., et al., 2001, "Characteristics of pullout failure in conical and cylindrical pedicle screws after full insertion and back-out," *The Spine Journal*, **1**(6), pp. 408-414. DOI: 10.1016/S1529-9430(01)00119-X
- [15] Halvorson, T.L., et al., 1994, "Effects of bone mineral density on pedicle screw fixation," *Spine*, **19**(21), pp. 2415-2420. DOI: 10.1097/00007632-199411000-00008
- [16] Soshi, S., et al., 1991, "An experimental study on transpedicular screw fixation in relation to osteoporosis of the lumbar spine," *Spine*, **16**(11), pp. 1335-1341. DOI: 10.1097/00007632-199111000-00015
- [17] Wittenberg, R.H., et al., 1993, "Effect of screw diameter, insertion technique, and bone cement augmentation of pedicular screw fixation strength," *Clinical orthopaedics and related research*, **296**, pp. 278. DOI: 10.1097/00003086-199311000-00045
- [18] Brantley, A.G., et al., 1994, "The effects of pedicle screw fit: an in vitro study," *Spine*, **19**(15), pp. 1752-1758. DOI: 10.1097/00007632-199408000-00016
- [19] Hirano, T., et al., 1997, "Structural characteristics of the pedicle and its role in screw stability," *Spine*, **22**(21), pp. 2504-2510. DOI: 10.1097/00007632-199711010-00007
- [20] Kumano, K., et al., 1994, "Pedicle screws and bone mineral density," *Spine*, **19**(10), pp. 1157-1161. DOI: 10.1097/00007632-199405001-00012
- [21] Kim, Y.-Y., W.-S. Choi, and K.-W. Rhyu, 2012, "Assessment of pedicle screw pullout strength based on various screw designs and bone densities—an ex vivo biomechanical study," *The Spine Journal*, **12**(2), pp. 164-168. DOI: 10.1016/j.spinee.2012.01.014
- [22] Hashemi, A., D. Bednar, and S. Ziada, 2009, "Pullout strength of pedicle screws augmented with particulate calcium phosphate: an experimental study," *The Spine Journal*, **9**(5), pp. 404-410. DOI: 10.1016/j.spinee.2008.07.001
- [23] Patel, P.S.D., D.E.T. Shepherd, and D.W.L. Hukins, 2010, "The effect of screw insertion angle and thread type on the pullout strength of bone screws in normal and osteoporotic cancellous bone models," *Medical engineering & physics*, **32**(8), pp. 822-828. DOI: 10.1016/j.medengphy.2010.05.005
- [24] McLain, R.F., et al., 1997, "The effect of bone quality on pedicle screw loading in axial instability: A synthetic model," *Spine*, **22**(13), pp. 1454. DOI: 10.1097/00007632-199707010-00006
- [25] Paik, H., et al., 2012, "The biomechanical effect of pedicle screw hubbing on pullout resistance in the thoracic spine," *The Spine Journal*, **12**(5), pp. 417-424. DOI: 10.1016/j.spinee.2012.03.020

- [26] Johnston, T.L., et al., 2006, "Cervical pedicle screws vs. lateral mass screws: uniplanar fatigue analysis and residual pullout strengths," *The Spine Journal*, **6**(6), pp. 667-672. DOI: 10.1016/j.spinee.2006.03.019
- [27] Zindrick, M.R., et al., 1986, "A biomechanical study of intrapeduncular screw fixation in the lumbosacral spine," *Clinical orthopaedics and related research*, **203**, pp. 99-112. DOI: 10.1097/00003086-198602000-00012
- [28] Okuyama, K., et al., 1993, "Stability of transpedicle screwing for the osteoporotic spine: an in vitro study of the mechanical stability," *Spine*, **18**(15), pp. 2240-2245. DOI: 10.1097/00007632-199311000-00016
- [29] Lotz, J.C., et al., 1997, "Carbonated apatite cement augmentation of pedicle screw fixation in the lumbar spine." *Spine*, **22**(23), pp. 2716. DOI: 10.1097/00007632-199712010-00003
- [30] Zdeblick, T.A., et al., 1993, "Pedicle screw pullout strength: Correlation with insertional torque," *Spine*, **18**(12), pp. 1673. DOI: 10.1097/00007632-199309000-00016
- [31] Myers, B.S., et al., 1996, "The role of imaging and in situ biomechanical testing in assessing pedicle screw pull-out strength," *Spine*, **21**(17), pp. 1962. DOI: 10.1097/00007632-199609010-00004
- [32] İnceoğlu, S., et al., 2006, "Axial cyclic behavior of the bone–screw interface," *Medical engineering & physics*, **28**(9), pp. 888-893. DOI: 10.1016/j.medengphy.2005.12.009
- [33] Aerssens, J., et al., 1998, "Interspecies Differences in Bone Composition, Density, and Quality: Potential Implications for in Vivo Bone Research 1," *Endocrinology*, **139**(2), pp. 663-670. DOI: 10.1210/en.139.2.663
- [34] Dath, R., et al., 2007, "Anatomical measurements of porcine lumbar vertebrae," *Clinical biomechanics*, **22**(5), pp. 607-613. DOI: 10.1016/j.clinbiomech.2007.01.014
- [35] McLain, R.F., S.A. Yerby, and T.A. Moseley, 2002, "Comparative morphometry of L4 vertebrae: comparison of large animal models for the human lumbar spine," *Spine*, **27**(8), pp. E200-E206.
- [36] Aslani, F.J., D.W. Hukins, and D.E. Shepherd, 2012, "Applicability of sheep and pig models for cancellous bone in human vertebral bodies," *Proceeding of the Institution of Mechanical Engineers, Part H: Journal of Engineering in Medicine*, **226**(1), pp. 76-78. DOI: 10.1177/0954411911426807
- [37] Zindrick, M.R., et al., 1987, "Analysis of the morphometric characteristics of the thoracic and lumbar pedicles," *Spine*, **12**(2), pp. 160-166. DOI: 10.1097/00007632-198703000-00012
- [38] Levasseur, A., H.-L. Ploeg, and Y. Petit, 2012, "Comparison of the influences of structural characteristics on bulk mechanical behaviour: experimental study using a bone surrogate," *Medical & biological engineering & computing*, **50**(1), pp. 61-67. DOI: 10.1007/s11517-011-0763-x

[39] ASTM, F543-07, 2007, "Standard Specification and Test methods for Metallic Medical Bone Screws," American Society for Testing and Materials: West Conshohocken, PA.

Figure Captions List

- Fig. 1 Toggling test set-up. Each specimen was secured in a custom fixture using polyester resin allowing change of orientation for: (a) CC and (b) ML toggling.
- Fig. 2 Pullout test setup. Each specimen was embedded in polyester resin and secured into custom fixture allowing alignment of pedicle screw head with the shackle gripped by the material testing system shaft for pullout.
- Fig. 3 Pareto charts of the standardized effect of toggling mode and vertebral level on the pedicle screw: (a) pullout force and; (b) stiffness. Blue lines define the thresholds for significant effects ($p < 0.05$).
- Fig. 4 2D contour plot for: (a) pullout force and (b) stiffness as a function of toggling modes and vertebral levels. The maximum pullout force was observed at L1 for NT mode whereas the minimum pullout force is shown at L3 for CC mode. The stiffness increased from L1 to L3 levels and from CC to NT modes.
- Fig. 5 Comparison of pedicle screw: (a) pullout force and (b) stiffness between CC, ML and NT toggling modes. Significant differences ($P < 0.05$) are shown by an asterisk (*).

Table Caption List

- Table 1 Design of experiment investigating the effect of toggling mode and vertebral level on pedicle screw fixation strength
- Table 2 Mean \pm SD values for pedicle area (Ped.A), length (Ped.H) and width (Ped.W)

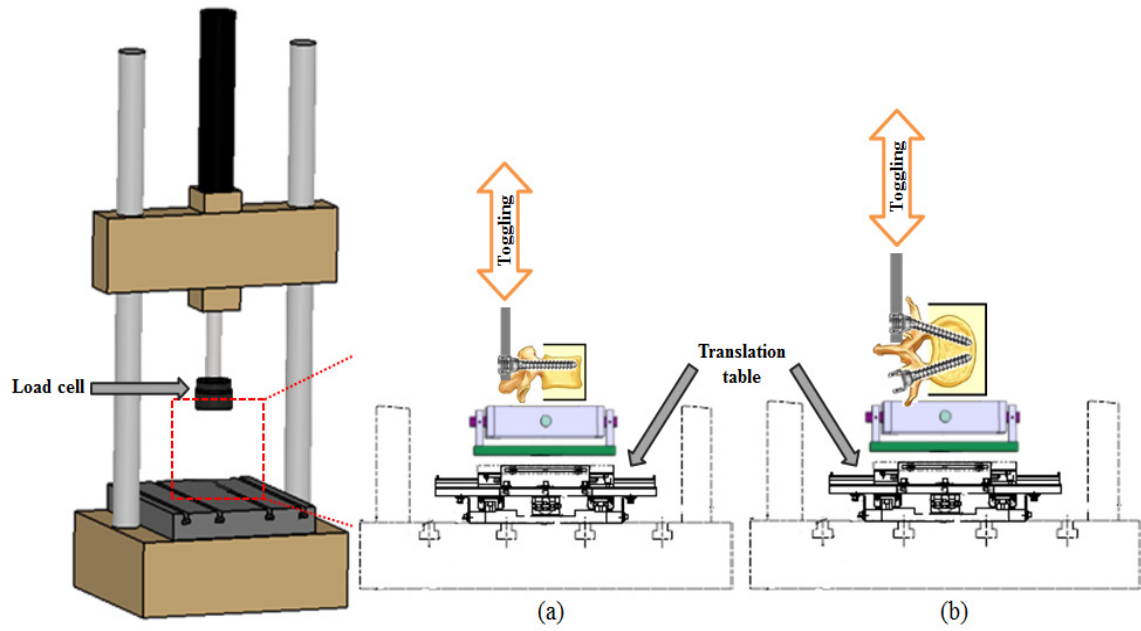

Fig. 1 Toggling test set-up. Each specimen was secured in a custom fixture using polyester resin allowing change of orientation for: (a) CC and (b) ML toggling.

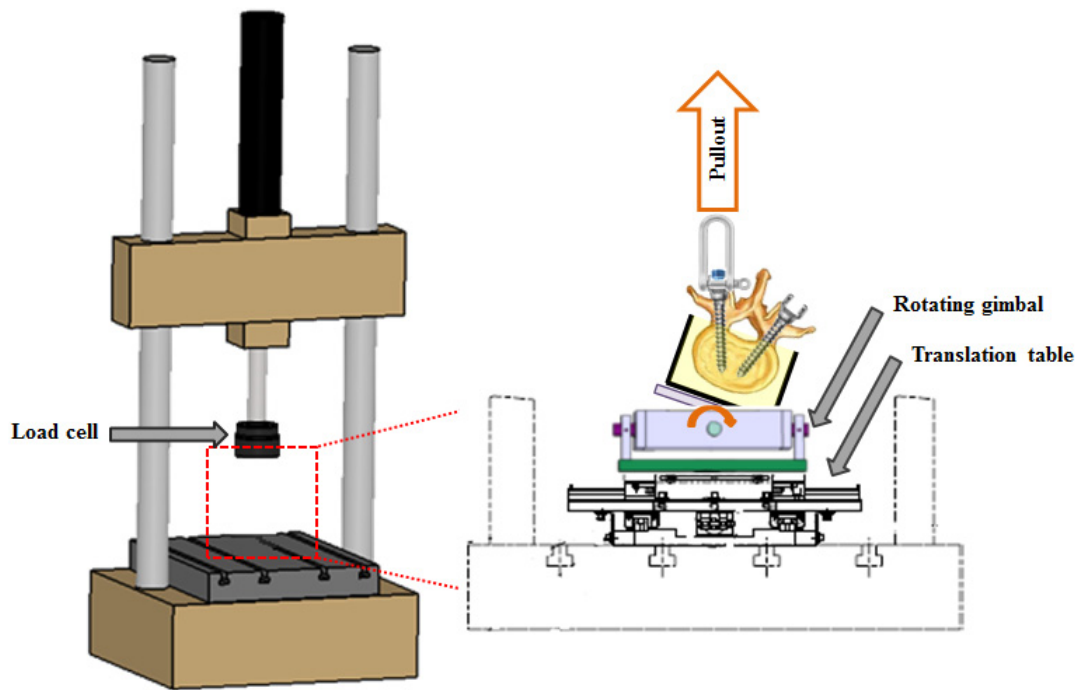
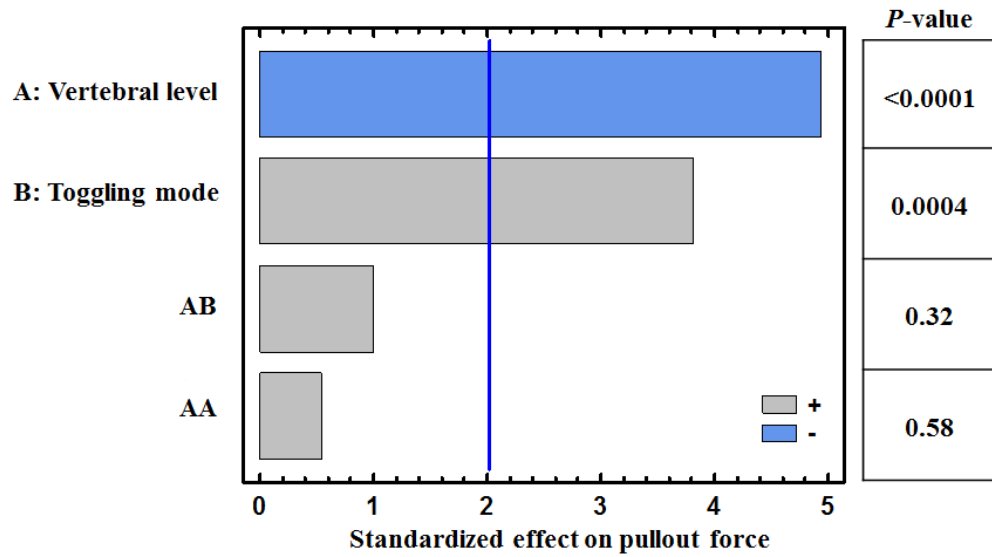
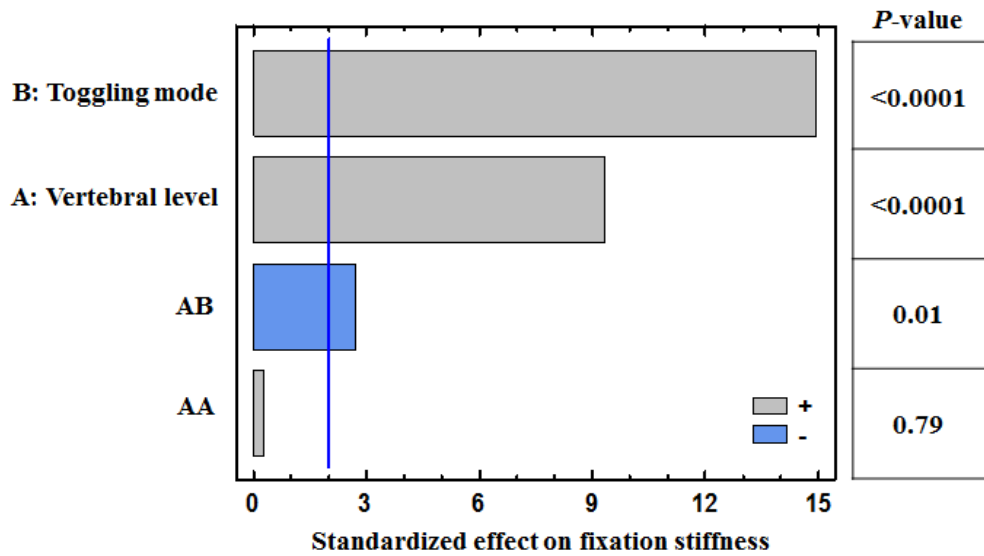

Fig. 2 Pullout test setup. Each specimen was embedded in polyester resin and secured into custom fixture allowing alignment of pedicle screw head with the shackle gripped by the material testing system shaft for pullout.



(a)



(b)

Fig. 3 Pareto charts of the standardized effect of toggling mode and vertebral level on the pedicle screw: (a) pullout force and; (b) stiffness. Blue lines define the thresholds for significant effects ($p < 0.05$).

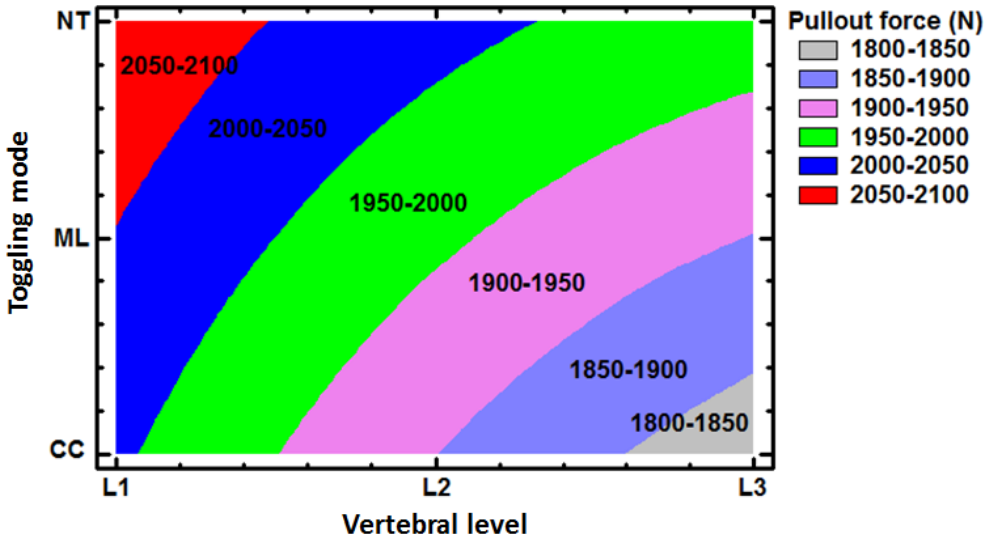

(a)

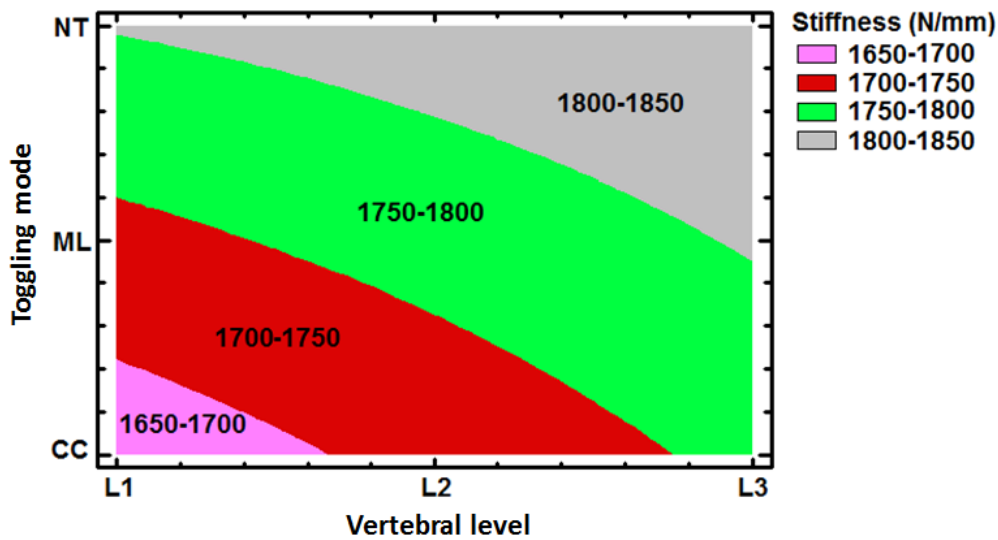

(b)

Fig. 4 2D contour plot for: (a) pullout force and (b) stiffness as a function of toggling modes and vertebral levels. The maximum pullout force was observed at L1 for NT mode whereas the minimum pullout force is shown at L3 for CC mode. The stiffness increased from L1 to L3 levels and from CC to NT modes.

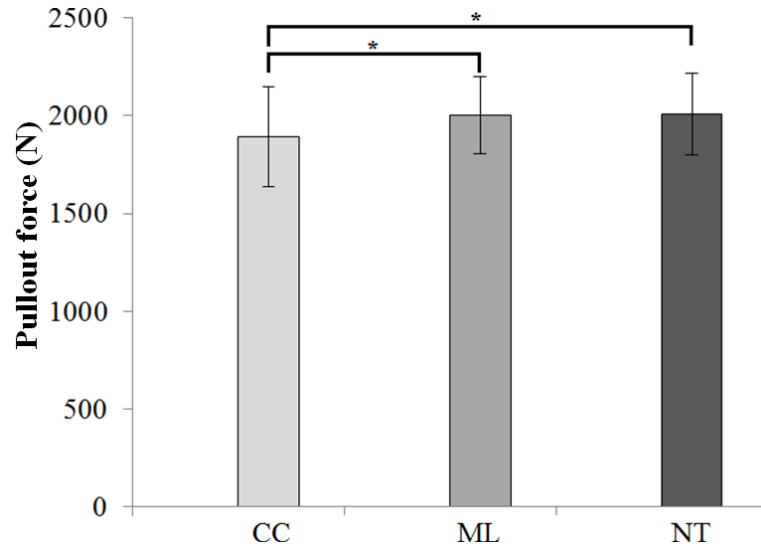

(a)

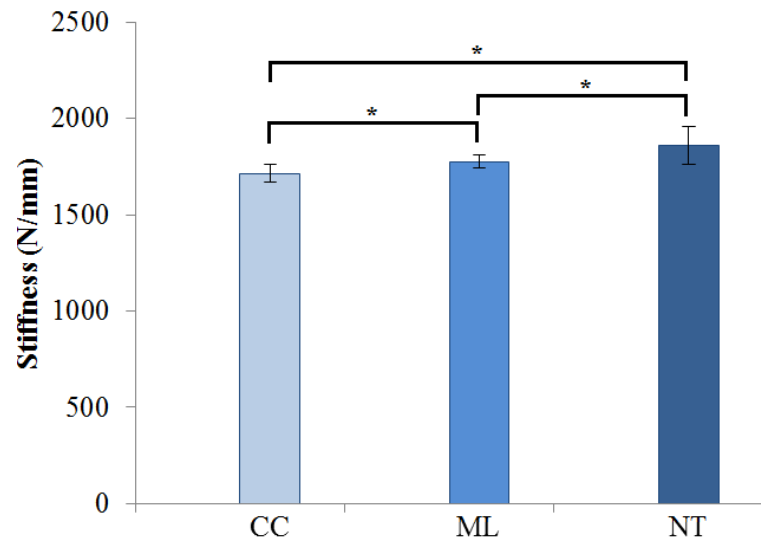

(b)

Fig. 5 Comparison of pedicle screw: (a) pullout force and (b) stiffness between CC, ML and NT toggling modes. Significant differences ($P < 0.05$) are shown by an asterisk (*).

Table 1 Design of experiment investigating the effect of toggling mode and vertebral level on pedicle screw fixation strength

Experimental factors	Experimental Levels		
	1	2	3
A: Toggling mode	CCa	MLb	NTc
B: Vertebral level	L1	L2	L3

Repetition: 5

aCC: craniocaudal, bML: mediolateral, cNT: no toggling

Table 2 Mean \pm SD values for pedicle area (Ped.A), length (Ped.H) and width (Ped.W)

Characteristic	Ped.A (mm ²)	Ped.L (mm)	Ped.W (mm)	BMD (g/cm ³)
L1	728 \pm 160	11.7 \pm 1.4	7.5 \pm 0.7	0.32 \pm 0.04
L2	794 \pm 237	11.8 \pm 1.3	7.7 \pm 0.7	0.29 \pm 0.05
L3	957 \pm 202	11.9 \pm 1.2	7.8 \pm 0.8	0.28 \pm 0.05
Total Mean	827 \pm 221	11.8 \pm 1.2	7.7 \pm 0.7	0.30 \pm 0.05

BIBLIOGRAPHY

- Abshire, Bret B, Robert F McLain, Antonio Valdevit and Helen E Kambic. 2001. « Characteristics of pullout failure in conical and cylindrical pedicle screws after full insertion and back-out ». *The Spine Journal*, vol. 1, n° 6, p. 408-414.
- Aerssens, J., S. Boonen, G. Lowet and J. Dequeker. 1998. « Interspecies differences in bone composition, density, and quality: potential implications for in vivo bone research ». *Endocrinology*, vol. 139, n° 2, p. 663.
- American Society for Testing and Materials, ASTM. 2007a. *Standard Specification and Test methods for Metallic Medical Bone Screws*. ASTM International, F 543 - 07. West Conshohocken, PA: American Society for Testing and Materials.
- American Society for Testing and Materials, ASTM. 2007b. *Standard specification for rigid polyurethane foam for use as a standard material for testing orthopedic devices and instruments*. ASTM International, F 1839-01. West Conshohocken, PA: American Society for Testing and Materials.
- Ammann, P., and R. Rizzoli. 2003. « Bone strength and its determinants ». *Osteoporosis international*, vol. 14, p. 13-18.
- Anatomy Body Gallery, Human anatomy 2009. « Spinal column anatomy ». Online. <<http://anatomybodygallery.com/spinal-column-anatomy/1616>>. Accessed September 20, 2014.
- Asher, Marc, William Carson, Charles Heinig, Walter Strippgen, Marcia Arendt, Richard Lark and Mark Hartley. 1988. « A modular spinal rod linkage system to provide rotational stability ». *Spine*, vol. 13, n° 3, p. 272-277.
- Aslani, Farnaz Jabbary, David WL Hukins and Duncan ET Shepherd. 2012. « Applicability of sheep and pig models for cancellous bone in human vertebral bodies ». *Proceedings of the Institution of Mechanical Engineers, Part H: Journal of Engineering in Medicine*, vol. 226, n° 1, p. 76-78.
- Au, A.G., A.K. Aiyangar, P.A. Anderson and H.L. Ploeg. 2011. « A New Bone Surrogate Model for Testing Interbody Device Subsidence ». *Spine*.

- Banase, Xavier, TJ Sims and AJ Bailey. 2002. « Mechanical Properties of Adult Vertebral Cancellous Bone: Correlation With Collagen Intermolecular Cross-Links ». *Journal of bone and mineral research*, vol. 17, n° 9, p. 1621-1628.
- Barber, J.W., S.D. Boden, T. Ganey and W.C. Hutton. 1998. « Biomechanical study of lumbar pedicle screws: does convergence affect axial pullout strength? ». *Journal of Spinal Disorders & Techniques*, vol. 11, n° 3, p. 215.
- Blumenthal, S, and K Gill. 1993. « Complications of the Wiltse pedicle screw fixation system ». *Spine*, vol. 18, n° 13, p. 1867-1871.
- Bogduk, Nikolai. 2005. *Clinical anatomy of the lumbar spine and sacrum*. Elsevier Health Sciences.
- Boisclair, Dominic, Jean-Marc Mac-Thiong, Stefan Parent and Yvan Petit. 2011. « Effect of spinal level and loading conditions on the production of vertebral burst fractures in a porcine model ». *Journal of biomechanical engineering*, vol. 133, n° 9, p. 094503.
- Bonnick, Sydney L. 2006. « Osteoporosis in men and women ». *Clinical cornerstone*, vol. 8, n° 1, p. 28-39.
- Boos, N, and JK Webb. 1997. « Pedicle screw fixation in spinal disorders: a European view ». *European Spine Journal*, vol. 6, n° 1, p. 2-18.
- Brantley, Anna GU, Jack K Mayfield, James B Koeneman and Kathleen R Clark. 1994. « The effects of pedicle screw fit: an in vitro study ». *Spine*, vol. 19, n° 15, p. 1752-1758.
- Briggs, AM, AM Greig and JD Wark. 2007. « The vertebral fracture cascade in osteoporosis: a review of aetiopathogenesis ». *Osteoporosis international*, vol. 18, n° 5, p. 575-584.
- Carballido-Gamio, J., and S. Majumdar. 2006. « Clinical utility of microarchitecture measurements of trabecular bone ». *Current osteoporosis reports*, vol. 4, n° 2, p. 64-70.
- Carmouche, Jonathan J, Robert W Molinari, Tad Gerlinger, John Devine and Troy Patience. 2005. « Effects of pilot hole preparation technique on pedicle screw fixation in

different regions of the osteoporotic thoracic and lumbar spine ». *Journal of Neurosurgery: Spine*, vol. 3, n° 5, p. 364-370.

- Carson, William L, Roger C Duffield, Marcia Arendt, Bobbie Jo Ridgely and Robert W Gaines Jr. 1990. « Internal Forces and Moments in Transpedicular Spine Instrumentation The Effect of Pedicle Screw Angle and Transfixation-The 4R-4Bar Linkage Concept ». *Spine*, vol. 15, n° 9, p. 893-901.
- Chao, Ching-Kong, Ching-Chi Hsu, Jaw-Lin Wang and Jinn Lin. 2008. « Increasing bending strength and pullout strength in conical pedicle screws: biomechanical tests and finite element analyses ». *Journal of spinal disorders & techniques*, vol. 21, n° 2, p. 130-138.
- Chapman, JR, RM Harrington, KM Lee, PA Anderson, AF Tencer and D. Kowalski. 1996. « Factors affecting the pullout strength of cancellous bone screws ». *Journal of biomechanical engineering*, vol. 118, p. 391.
- Chatzistergos, Panagiotis E, Evangelos A Magnissalis and Stavros K Kourkoulis. 2010. « A parametric study of cylindrical pedicle screw design implications on the pullout performance using an experimentally validated finite-element model ». *Medical engineering & physics*, vol. 32, n° 2, p. 145-154.
- Cheng, Li Ming, Jian Jie Wang, Zhi Li Zeng, Rui Zhu, Yan Yu, Chunbo Li and Zhou Rui Wu. 2013. « Pedicle screw fixation for traumatic fractures of the thoracic and lumbar spine ». *Cochrane Database of Systematic Reviews*, n° 5.
- Cheung, Wai Yuen, Lawrence G Lenke and Keith DK Luk. 2010. « Prediction of scoliosis correction with thoracic segmental pedicle screw constructs using fulcrum bending radiographs ». *Spine*, vol. 35, n° 5, p. 557-561.
- Coe, Jeffrey D, Karen E Warden, Mbiomed Engr, Michael A Herzig and Paul C McAfee. 1990. « Influence of bone mineral density on the fixation of thoracolumbar implants A comparative study of transpedicular screws, laminar hooks, and spinous process wires ». *Spine*, vol. 15, n° 9, p. 902-907.
- Cowin, Stephen C. 2001. *Bone biomechanics handbook*. Boca Raton, FL, CRC Press.
- Cunningham, Bryan W, Stephen J Lewis, John Long, Anton E Dmitriev, Douglas A Linville and Keith H Bridwell. 2002. « Biomechanical evaluation of lumbosacral

reconstruction techniques for spondylolisthesis: an in vitro porcine model ». *Spine*, vol. 27, n° 21, p. 2321-2327.

Daftari, T.K., W.C. Horton and W.C. Hutton. 1994. « Correlations between screw hole preparation, torque of insertion, and pullout strength for spinal screws ». *Journal of spinal disorders*, vol. 7, n° 2, p. 139.

Dath, R, AD Ebinesan, KM Porter and AW Miles. 2007. « Anatomical measurements of porcine lumbar vertebrae ». *Clinical biomechanics*, vol. 22, n° 5, p. 607-613.

Deckelmann, S., R. Schwyn, B. Van der Pol, M. Windolf, P.F. Heini and L.M. Benneker. 2010. « DensiProbe Spine: A Novel Instrument for Intraoperative Measurement of Bone Density in Transpedicular Screw Fixation ». *Spine*, vol. 35, n° 6, p. 607.

DePuy Synthes, Surgical technique. 2013. « URS system Top loading pedicle screw and hook system for posterior stabilization ». Retrieved from. < <http://www.synthes.com/MediaBin/International%20DATA/036.000.228.pdf> >. Accessed September 20, 2014.

DeWald, Christopher J, and Thomas Stanley. 2006. « Instrumentation-related complications of multilevel fusions for adult spinal deformity patients over age 65: surgical considerations and treatment options in patients with poor bone quality ». *Spine*, vol. 31, n° 19S, p. S144-S151.

Dick, J.C., T.A. Zdeblick, B.D. Bartel and D.N. Kunz. 1997. « Mechanical evaluation of cross-link designs in rigid pedicle screw systems ». *Spine*, vol. 22, n° 4, p. 370.

Dickman, C.A., R.G. Fessler, M. MacMillan and R.W. Haid. 1992. « Transpedicular screw-rod fixation of the lumbar spine: operative technique and outcome in 104 cases ». *Journal of neurosurgery*, vol. 77, n° 6, p. 860-870.

Diez-Perez, Adolfo, Roberto Güerri, Xavier Nogues, Enric Cáceres, Maria Jesus Pena, Leonardo Mellibovsky, Connor Randall, Daniel Bridges, James C Weaver and Alexander Proctor. 2010. « Microindentation for in vivo measurement of bone tissue mechanical properties in humans ». *Journal of Bone and Mineral Research*, vol. 25, n° 8, p. 1877-1885.

- Ebraheim, Nabil A, Robert E Rupp, Edward R Savolaine and Derek Reinke. 1994. « Use of titanium implants in pedicular screw fixation ». *Journal of Spinal Disorders & Techniques*, vol. 7, n° 6, p. 478-486.
- Esses, S.I., B.L. Sachs and V. Dreyzin. 1993. « Complications associated with the technique of pedicle screw fixation. A selected survey of ABS members ». *Spine*, vol. 18, n° 15, p. 2231.
- Gaines Jr, R.W. 2000. « CURRENT CONCEPTS REVIEW-The Use of Pedicle-Screw Internal Fixation for the Operative Treatment of Spinal Disorders ». *Journal of Bone and Joint Surgery-A-American Volumes*, vol. 82, n° 10, p. 1458-1477.
- Gordon, CL, TF Lang, P. Augat and HK Genant. 1998. « Image-based assessment of spinal trabecular bone structure from high-resolution CT images ». *Osteoporosis international*, vol. 8, n° 4, p. 317-325.
- Grynepas, M.D., D. Chachra and K. Lundon. 2000. « Bone quality in animal models of osteoporosis ». *Drug development research*, vol. 49, n° 3, p. 146-158.
- Haidekker, MA, R. Andresen and HJ Werner. 1999. « Relationship between structural parameters, bone mineral density and fracture load in lumbar vertebrae, based on high-resolution computed tomography, quantitative computed tomography and compression tests ». *Osteoporosis international*, vol. 9, n° 5, p. 433-440.
- Halvorson, Thomas L, Lee A Kelley, Kevin A Thomas, Thomas S Whitecloud III and Stephen D Cook. 1994. « Effects of bone mineral density on pedicle screw fixation ». *Spine*, vol. 19, n° 21, p. 2415-2420.
- Hansson, T., and B. Roos. 1980. « The influence of age, height, and weight on the bone mineral content of lumbar vertebrae ». *Spine*, vol. 5, n° 6, p. 545.
- Hashemi, A., D. Bednar and S. Ziada. 2009. « Pullout strength of pedicle screws augmented with particulate calcium phosphate: an experimental study ». *The Spine Journal*, vol. 9, n° 5, p. 404-410.
- Hasler, Carol C. 2013. « A brief overview of 100 years of history of surgical treatment for adolescent idiopathic scoliosis ». *Journal of children's orthopaedics*, vol. 7, n° 1, p. 57-62.

- Heaney, R.P. 1993. « Is there a role for bone quality in fragility fractures? ». *Calcified Tissue International*, vol. 53, p. 3-6.
- Hirano, Toru, Kazuhiro Hasegawa, Hideaki E Takahashi, Seiji Uchiyama, Toshiaki Hara, Toshikatsu Washio, Toru Sugiura, Motoo Yokaichiya and Masayuki Ikeda. 1997. « Structural characteristics of the pedicle and its role in screw stability ». *Spine*, vol. 22, n° 21, p. 2504-2510.
- Hitchon, Patrick W, Matthew D Brenton, Andrew G Black, Aaron From, Jeremy S Harrod, Christopher Barry, Hassan Serhan and James C Torner. 2003. « In vitro biomechanical comparison of pedicle screws, sublaminar hooks, and sublaminar cables ». *Journal of Neurosurgery: Spine*, vol. 99, n° 1, p. 104-109.
- Hobatho, MC, J Young Rho and RB Ashman. 1997. « Mechanical Properties and Predictive Relationships of the Lumbar Spine ». *Studies in health technology and informatics*, p. 181-184.
- Hsu, C.C., C.K. Chao, J.L. Wang, S.M. Hou, Y.T. Tsai and J. Lin. 2005. « Increase of pullout strength of spinal pedicle screws with conical core: biomechanical tests and finite element analyses ». *Journal of orthopaedic research*, vol. 23, n° 4, p. 788-794.
- Hulme, PA, SK Boyd and SJ Ferguson. 2007. « Regional variation in vertebral bone morphology and its contribution to vertebral fracture strength ». *Bone*, vol. 41, n° 6, p. 946-957.
- Inceoglu, S., L. Ferrara and R.F. McLain. 2004. « Pedicle screw fixation strength: pullout versus insertional torque ». *The Spine Journal*, vol. 4, n° 5, p. 513-518.
- İnceoğlu, Serkan, Mike Ehlert, Atilla Akbay and Robert F McLain. 2006. « Axial cyclic behavior of the bone–screw interface ». *Medical engineering & physics*, vol. 28, n° 9, p. 888-893.
- Inuid, Azusa, Kazuhito Itamotoz, Tetsuya Takuma, Hideki Tsutsumi, Manabu Tanigawa, Mineo Hayasaki, Yasuho Tauraz and Koichi Mamba. 2004. « Age-Related Changes of Bone Mineral Density and Microarchitecture in Miniature ». *J. Vet. Med. Sci*, vol. 66, n° 6, p. 599-609.

- Ito, M., K. Hayashi, M. Uetani, Y. Kawahara, M. Ohki, M. Yamada, H. Kitamori and M. Noguchi. 1993. « Bone mineral and other bone components in vertebrae evaluated by QCT and MRI ». *Skeletal radiology*, vol. 22, n° 2, p. 109-113.
- Ito, M., K. Ikeda, M. Nishiguchi, H. Shindo, M. Uetani, T. Hosoi and H. Orimo. 2005. « Multi-Detector Row CT Imaging of Vertebral Microstructure for Evaluation of Fracture Risk ». *Journal of Bone and Mineral Research*, vol. 20, n° 10, p. 1828-1836.
- Johnston, Todd L, Eldin E Karaikovic, Eugene P Lautenschlager and David Marcu. 2006. « Cervical pedicle screws vs. lateral mass screws: uniplanar fatigue analysis and residual pullout strengths ». *The Spine Journal*, vol. 6, n° 6, p. 667-672.
- Katonis, Pavlos, Joseph Christoforakis, Agisilaos C Aligizakis, Charalampos Papadopoulos, George Sapkas and Alexander Hadjipavlou. 2003. « Complications and problems related to pedicle screw fixation of the spine ». *Clinical orthopaedics and related research*, vol. 411, p. 86-94.
- Keen, Richard. 2007. « Osteoporosis: strategies for prevention and management ». *Best Practice & Research Clinical Rheumatology*, vol. 21, n° 1, p. 109-122.
- Kentucky Community and Technical College System, Anatomy and physiology. 2014. « Skeletal anatomy: Vertebrae and thoracic cage ». Online. < <http://legacy.owensboro.kctcs.edu/gcaplan/anat/notes/api%20notes%20h%20skeletal%20vertebrae.htm> >. Accessed September 20, 2014.
- Kilbanski, Anne, Lucile Adams-Campbell, Tamsen Bassford, Steven N Blair, Scott D Boden, Kay Dickersin, David R Gifford, Lou Glasse, Steven R Goldring and Keith Hruska. 2001. « Osteoporosis prevention, diagnosis, and therapy ». *JAMA: Journal of the American Medical Association*, vol. 285, n° 6, p. 785.
- Kim, Yongjung J, Lawrence G Lenke, Samuel K Cho, Keith H Bridwell, Brenda Sides and Kathy Blanke. 2004. « Comparative analysis of pedicle screw versus hook instrumentation in posterior spinal fusion of adolescent idiopathic scoliosis ». *Spine*, vol. 29, n° 18, p. 2040-2048.
- Kim, Young-Yul, Woo-Sung Choi and Kee-Won Rhyu. 2012. « Assessment of pedicle screw pullout strength based on various screw designs and bone densities—an ex vivo biomechanical study ». *The Spine Journal*, vol. 12, n° 2, p. 164-168.

- Kim, Young, and Tae-Won Kim. 2010. « Finite element analysis of the effects of pedicle screw fixation nut loosening on lumbar interbody fusion based on the elasto-plateau plasticity of bone characteristics ». *Spine*, vol. 35, n° 6, p. 599-606.
- Kothe, Ralph, Manohar M Panjabi and Wen Liu. 1997. « Multidirectional instability of the thoracic spine due to iatrogenic pedicle injuries during transpedicular fixation: a biomechanical investigation ». *Spine*, vol. 22, n° 16, p. 1836-1842.
- Krag, M.H., D.L. Weaver, B.D. Beynnon and L.D. Haugh. 1988. « Morphometry of the thoracic and lumbar spine related to transpedicular screw placement for surgical spinal fixation ». *Spine*, vol. 13, n° 1, p. 27.
- Krenn, Michael Hannes, Wolfgang Peter Piotrowski, Rainer Penzkofer and Peter Augat. 2008. « Influence of thread design on pedicle screw fixation ».
- Kumano, Kiyoshi, Shigeru Hirabayashi, Yutaka Ogawa and Yohichi Aota. 1994. « Pedicle screws and bone mineral density ». *Spine*, vol. 19, n° 10, p. 1157-1161.
- Kurtz, Steven M, and Avram Edidin. 2006. *Spine technology handbook*. Academic Press.
- Kwok, A.W.L., J.A. Finkelstein, T. Woodside, T.C. Hearn and R.W. Hu. 1996. « Insertional torque and pull-out strengths of conical and cylindrical pedicle screws in cadaveric bone ». *Spine*, vol. 21, n° 21, p. 2429.
- Law, Melvin, Allan F Tencer and Paul A Anderson. 1993. « Caudo-cephalad loading of pedicle screws: mechanisms of loosening and methods of augmentation ». *Spine*, vol. 18, n° 16, p. 2438-2443.
- Lee, JH, JW Park and YH Shin. 2012. « The insertional torque of a pedicle screw has a positive correlation with bone mineral density in posterior lumbar pedicle screw fixation ». *Journal of Bone and Joint Surgery-British Volume*, vol. 94, n° 1, p. 93.
- Lehman Jr, R.A., D.W. Polly Jr, T.R. Kuklo, B. Cunningham, K.L. Kirk and P.J. Belmont Jr. 2003. « Straight-forward versus anatomic trajectory technique of thoracic pedicle screw fixation: a biomechanical analysis ». *Spine*, vol. 28, n° 18, p. 2058.
- Leite, Vânia Custódio, Antônio Carlos Shimano, Gilson Antonio Pereira Gonçalves, Frank Kandziora and Helton Luiz Aparecido Defino. 2008. « The influence of insertion

- torque on pedicular screws' pullout resistance ». *Acta Ortopédica Brasileira*, vol. 16, n° 4, p. 214-216.
- Lenke, L.G., T.R. Kuklo, S. Ondra and D.W. Polly Jr. 2008. « Rationale behind the current state-of-the-art treatment of scoliosis (in the pedicle screw era) ». *Spine*, vol. 33, n° 10, p. 1051.
- Levasseur, A, H-L Ploeg and Y Petit. 2012. « Comparison of the influences of structural characteristics on bulk mechanical behaviour: experimental study using a bone surrogate ». *Medical & biological engineering & computing*, vol. 50, n° 1, p. 61-67.
- Li, Qin-liang, Xiu-Zhong Li, Yi Liu, Hu-sheng Zhang, Peng Shang, Zhao-ming Chu, Jinchuan Chen, Ming Chen and Rujie Qin. 2013. « Treatment of thoracolumbar fracture with pedicle screws at injury level: a biomechanical study based on three-dimensional finite element analysis ». *European Journal of Orthopaedic Surgery & Traumatology*, vol. 23, n° 7, p. 775-780.
- Lin, Cheng-Li, Chih-Kai Hong, I Jou, Chii-Jeng Lin, Fong-Chin Su and Wei-Ren Su. 2012. « Suture anchor versus screw fixation for greater tuberosity fractures of the humerus—a biomechanical study ». *Journal of orthopaedic research*, vol. 30, n° 3, p. 423-428.
- Lin, Ruey-Mo, Kuen-Horng Tsai and Guan-Liang Chang. 1997. « Distribution and regional strength of trabecular bone in the porcine lumbar spine ». *Clinical Biomechanics*, vol. 12, n° 5, p. 331-336.
- Longnecker, Micheal, and Rober Ott. 2001. « An introduction to statistical methods and data analysis ». *ISBN-13*, vol. 854576151.
- Lotz, J.C., S.S. Hu, D.F.M. Chiu, M. Yu, O. Colliou and R.D. Poser. 1997. « Carbonated apatite cement augmentation of pedicle screw fixation in the lumbar spine ». *Spine*, vol. 22, n° 23, p. 2716.
- Margulies, JY, RS Casar, SA Caruso, MG Neuwirth and TR Hafer. 1997. « The mechanical role of laminar hook protection of pedicle screws at the caudal end vertebra ». *European Spine Journal*, vol. 6, n° 4, p. 245-248.

- Matsuzaki, H., Y. Tokuhashi, F. Matsumoto, M. Hoshino, T. Kiuchi and S. Toriyama. 1990. « Problems and solutions of pedicle screw plate fixation of lumbar spine ». *Spine*, vol. 15, n° 11, p. 1159-1165.
- McLain Robert, F, Timothy A Moseley and Neil A Sharkey. 1995. « Lumbar pedicle screw salvage: pullout testing of three different pedicle screw designs ». *Journal of Spinal Disorders & Techniques*, vol. 8, n° 1, p. 62-68.
- McLain, R.F., T.O. McKinley, S.A. Yerby, T.S. Smith and N. Sarigul-Klijn. 1997. « The effect of bone quality on pedicle screw loading in axial instability: A synthetic model ». *Spine*, vol. 22, n° 13, p. 1454.
- McLain, RF, E Sparling and DR Benson. 1993. « Early failure of short-segment pedicle instrumentation for ». *J Bone Joint Surg Am*, vol. 75, p. 162-167.
- McLain, Robert F, Scott A Yerby and Timothy A Moseley. 2002. « Comparative morphometry of L4 vertebrae: comparison of large animal models for the human lumbar spine ». *Spine*, vol. 27, n° 8, p. E200-E206.
- Mehta, H., E. Santos, C. Ledonio, J. Sembrano, A. Ellingson, P. Pare, B. Murrell and DJ Nuckley. 2011. « Biomechanical analysis of pedicle screw thread differential design in an osteoporotic cadaver model ». *Clinical Biomechanics*.
- Myers, B.S., P.J. Belmont Jr, W.J. Richardson, J.R. Yu, K.D. Harper and R.W. Nightingale. 1996. « The role of imaging and in situ biomechanical testing in assessing pedicle screw pull-out strength ». *Spine*, vol. 21, n° 17, p. 1962.
- Myers, Elizabeth R, and Sara E Wilson. 1997. « Biomechanics of osteoporosis and vertebral fracture ». *Spine*, vol. 22, n° 24, p. 25S-31S.
- Nagy, T.R., C.W. Prince and J. Li. 2001. « Validation of Peripheral Dual Energy X Ray Absorptiometry for the Measurement of Bone Mineral in Intact and Excised Long Bones of Rats* ». *Journal of Bone and Mineral Research*, vol. 16, n° 9, p. 1682-1687.
- Okuyama, Koichiro, Eiji Abe, Tetsuya Suzuki, Yasuki Tamura, Mitsuho Chiba and Kozo Sato. 2001. « Influence of bone mineral density on pedicle screw fixation: a study of pedicle screw fixation augmenting posterior lumbar interbody fusion in elderly patients ». *The Spine Journal*, vol. 1, n° 6, p. 402-407.

- Okuyama, Koichiro, Kozo Sato, Eiji Abe, Hitoshi Inaba, Yoichi Shimada and Hajime Murai. 1993. « Stability of transpedicle screwing for the osteoporotic spine: an in vitro study of the mechanical stability ». *Spine*, vol. 18, n° 15, p. 2240-2245.
- Paik, Haines, Anton E Dmitriev, Ronald A Lehman Jr, Rachel E Gaume, Divya V Ambati, Daniel G Kang and Lawrence G Lenke. 2012. « The biomechanical effect of pedicle screw hubbing on pullout resistance in the thoracic spine ». *The Spine Journal*, vol. 12, n° 5, p. 417-424.
- Parker, S.L., M.J. McGirt, S.H. Farber, A.G. Amin, A.M. Rick, I. Suk, A. Bydon, D.M. Sciubba, J.P. Wolinsky and Z.L. Gokaslan. 2011. « Accuracy of free-hand pedicle screws in the thoracic and lumbar spine: analysis of 6816 consecutive screws ». *Neurosurgery*, vol. 68, n° 1, p. 170.
- Patel, P.S.D., D.E.T. Shepherd and D.W.L. Hukins. 2010. « The effect of screw insertion angle and thread type on the pullout strength of bone screws in normal and osteoporotic cancellous bone models ». *Medical engineering & physics*, vol. 32, n° 8, p. 822-828.
- Petersilge, Cheryl A, JS Lewin, Jeffrey L Duerk, Jung U Yoo and Alexander J Ghaneyem. 1996. « Optimizing imaging parameters for MR evaluation of the spine with titanium pedicle screws ». *AJR. American journal of roentgenology*, vol. 166, n° 5, p. 1213-1218.
- Pihlajamäki, Harri, Pertti Myllynen and Ole Böstman. 1997. « Complications of transpedicular lumbosacral fixation for non-traumatic disorders ». *Journal of Bone & Joint Surgery, British Volume*, vol. 79, n° 2, p. 183-189.
- Ponnusamy, K.E., S. Iyer, G. Gupta and A.J. Khanna. 2011. « Instrumentation of the osteoporotic spine: biomechanical and clinical considerations ». *The Spine Journal*, vol. 11, n° 1, p. 54-63.
- Reitman, Charles Alan, Lyndon Nguyen and Guy R Fogel. 2004. « Biomechanical evaluation of relationship of screw pullout strength, insertional torque, and bone mineral density in the cervical spine ». *Journal of spinal disorders & techniques*, vol. 17, n° 4, p. 306-311.

- Resnick, Daniel K, Tanvir F Choudhri, Andrew T Dailey, Michael W Groff, Larry Khoo, Paul G Matz, Praveen Mummaneni, William C Watters III, Jeffrey Wang and Beverly C Walters. 2005. « Guidelines for the performance of fusion procedures for degenerative disease of the lumbar spine. Part 12: pedicle screw fixation as an adjunct to posterolateral fusion for low-back pain ». *Journal of Neurosurgery: Spine*, vol. 2, n° 6, p. 700-706.
- Ronderos, Juan F, Ronald Jacobowitz, Volker KH Sonntag, Neil R Crawford and Curtis A Dickman. 1997. « Comparative pull-out strength of tapped and untapped pilot holes for bicortical anterior cervical screws ». *Spine*, vol. 22, n° 2, p. 167-170.
- Roy-Camille, Raymond, Gerard Saillant and Christian Mazel. 1986. « Internal fixation of the lumbar spine with pedicle screw plating ». *Clinical orthopaedics and related research*, vol. 203, p. 7-17.
- Ruland, Charles M, Paul C McAfee, Karen E Warden and Bryan W Cunningham. 1991. « Triangulation of pedicular instrumentation: a biomechanical analysis ». *Spine*, vol. 16, n° 6S, p. S270-S276.
- Sack, Wolfgang O. 1982. *Essentials of pig anatomy. Horowitz/Kramer atlas of musculoskeletal anatomy of the pig*. Veterinary Textbooks, 36 Woodcrest Avenue.
- Sanden, B, C Olerud, M Petren-Mallmin, C Johansson and S Larsson. 2004. « The significance of radiolucent zones surrounding pedicle screws, definition of screw loosening in spinal instrumentation ». *Journal of Bone & Joint Surgery, British Volume*, vol. 86, n° 3, p. 457-461.
- Sandén, B., C. Olerud, S. Larsson and Y. Robinson. 2010. « Insertion torque is not a good predictor of pedicle screw loosening after spinal instrumentation: a prospective study in 8 patients ». *Patient safety in surgery*, vol. 4, n° 1, p. 1-5.
- Sanderson, PL, Robert D Fraser, David John Hall, Christopher Marden John Cain, Orso Lorenzo Osti and GR Potter. 1999. « Short segment fixation of thoracolumbar burst fractures without fusion ». *European Spine Journal*, vol. 8, n° 6, p. 495-500.
- Sardone, Laura D. 2011. « The Effect of Rosiglitazone on Bone Quality in a Rat Model of Insulin Resistance and Osteoporosis ». Master dissertation in medicine and pathobiology. Toronto, University of Toronto, 147 p.

- Seeman, E. 2002. « Pathogenesis of bone fragility in women and men ». *The Lancet*, vol. 359, n° 9320, p. 1841-1850.
- Silva, M.J. 2007. « Biomechanics of osteoporotic fractures ». *Injury*, vol. 38, n° 3, p. 69-76.
- Soshi, Shigeru, Ritu Shiba, Hidemaru Kondo and Kagehisa Murota. 1991. « An experimental study on transpedicular screw fixation in relation to osteoporosis of the lumbar spine ». *Spine*, vol. 16, n° 11, p. 1335-1341.
- Suhm, Norbert, Clemens Hengg, Ronald Schwyn, Markus Windolf, Volker Quarz and Markus Hänni. 2007. « Mechanical torque measurement predicts load to implant cut-out: a biomechanical study investigating DHS® anchorage in femoral heads ». *Archives of orthopaedic and trauma surgery*, vol. 127, n° 6, p. 469-474.
- Suk, SI, CK Lee, HJ Min, KH Cho and JH Oh. 1994. « Comparison of Cotrel-Dubousset pedicle screws and hooks in the treatment of idiopathic scoliosis ». *International orthopaedics*, vol. 18, n° 6, p. 341-346.
- Tai, Ching-Lung, Li-Huei Chen, De-Mei Lee, Mu-Yi Liu and Po-Liang Lai. 2014. « Biomechanical comparison of different combinations of hook and screw in one spine motion unit-an experiment in porcine model ». *BMC musculoskeletal disorders*, vol. 15, n° 1, p. 197.
- Teoh, SH, and CK Chui. 2008. « Bone material properties and fracture analysis: Needle insertion for spinal surgery ». *Journal of the mechanical behavior of biomedical materials*, vol. 1, n° 2, p. 115-139.
- Turner, CH. 2002. « Biomechanics of bone: determinants of skeletal fragility and bone quality ». *Osteoporosis international*, vol. 13, n° 2, p. 97-104.
- Vaccaro, Alexander R, David H Kim, Darrel S Brodke, Mitchel Harris, Jens Chapman, Thomas Schildhauer, ML Chip Routt and Rick C Sasso. 2003. « Diagnosis and management of thoracolumbar spine fractures ». *The Journal of Bone & Joint Surgery*, vol. 85, n° 12, p. 2456-2470.
- Van Ee, CA, AL Chasse and BS Myers. 2000. « Quantifying skeletal muscle properties in cadaveric test specimens: effects of mechanical loading, postmortem time, and freezer storage ». *Journal of biomechanical engineering*, vol. 122, n° 1, p. 9-14.

- Wang, X., C.E. Aubin, D. Crandall and H. Labelle. 2011. « Biomechanical Comparison of Force Levels in Spinal Instrumentation Using Monoaxial versus Multi Degree of Freedom Postloading Pedicle Screws ». *Spine*, vol. 36, n° 2, p. E95.
- Wittenberg, R.H., K.S. Lee, M. Shea, A.A. WHITE III and W.C. Hayes. 1993. « Effect of screw diameter, insertion technique, and bone cement augmentation of pedicular screw fixation strength ». *Clinical orthopaedics and related research*, vol. 296, p. 278.
- Yazici, Muharrem, Murat Pekmezci, Akin Cil, Ahmet Alanay, Emre Acaroglu and Fethullah C Oner. 2006. « The effect of pedicle expansion on pedicle morphology and biomechanical stability in the immature porcine spine ». *Spine*, vol. 31, n° 22, p. E826-E829.
- Zdeblick, T.A., D.N. Kunz, M.E. Cooke and R. McCabe. 1993. « Pedicle screw pullout strength: Correlation with insertional torque ». *Spine*, vol. 18, n° 12, p. 1673.
- Zhang, QH, SH Tan and SM Chou. 2004. « Investigation of fixation screw pull-out strength on human spine ». *Journal of biomechanics*, vol. 37, n° 4, p. 479-485.
- Zindrick, Michael R, Leon L Wiltse, Albert Doornik, Eric H Widell, Gary W Knight, Avinash G Patwardhan, James C Thomas, Stephen L Rothman and BT Fields. 1987. « Analysis of the morphometric characteristics of the thoracic and lumbar pedicles ». *Spine*, vol. 12, n° 2, p. 160-166.
- Zindrick, Michael R, Leon L Wiltse, Eric H Widell, JAMES C THOMAS, W Russell Holland, B TED FIELD and CURTIS W SPENCER. 1986. « A biomechanical study of intrapeduncular screw fixation in the lumbosacral spine ». *Clinical orthopaedics and related research*, vol. 203, p. 99-112.
- Zysset, PK. 2009. « Indentation of bone tissue: a short review ». *Osteoporosis international*, vol. 20, n° 6, p. 1049-1055.