



## Enhanced AIMD based decentralized residential charging of EVs

Liu, M., & McLoone, S. (2015). Enhanced AIMD based decentralized residential charging of EVs. Transactions of the Institute of Measurement and Control, 37(7), 853-867. DOI: 10.1177/0142331213494100

### Published in:

Transactions of the Institute of Measurement and Control

### Document Version:

Peer reviewed version

### Queen's University Belfast - Research Portal:

[Link to publication record in Queen's University Belfast Research Portal](#)

### Publisher rights

© 2013 The Authors

### General rights

Copyright for the publications made accessible via the Queen's University Belfast Research Portal is retained by the author(s) and / or other copyright owners and it is a condition of accessing these publications that users recognise and abide by the legal requirements associated with these rights.

### Take down policy

The Research Portal is Queen's institutional repository that provides access to Queen's research output. Every effort has been made to ensure that content in the Research Portal does not infringe any person's rights, or applicable UK laws. If you discover content in the Research Portal that you believe breaches copyright or violates any law, please contact [openaccess@qub.ac.uk](mailto:openaccess@qub.ac.uk).

---

# Enhanced AIMD based decentralized residential charging of EVs

Mingming Liu<sup>1</sup> and Seán McLoone<sup>2,3</sup>

<sup>1</sup> Hamilton Institute, NUIM, Maynooth, Ireland

<sup>2</sup> Department of Electronic Engineering, NUIM, Maynooth, Ireland;

<sup>3</sup> Energy, Power and Intelligent Control Research Cluster, Queen's University of Belfast, Belfast, UK

Moving from combustion engine to Electric Vehicle (EV) based transport is recognized as having a major role to play in reducing pollution, combating climate change and improving energy security. However, the introduction of EVs poses major challenges for power system operation. With increasing penetration of EVs uncontrolled coincident charging may overload the grid and substantially increase peak power requirements. Developing smart grid technologies and appropriate charging strategies to support the role out of EVs is therefore a high priority. In this paper we investigate the effectiveness of distributed Additive Increase and Multiplicative Decrease (AIMD) charging algorithms, as proposed in (Stüdl *et al.*, 2012a, 2012b), at mitigating the impact of domestic charging of EVs on low-voltage distribution networks. In particular, a number of enhancements to the basic AIMD implementation are introduced to enable local power system infrastructure and voltage level constraints to be taken into account and to reduce peak power requirements. The enhanced AIMD EV charging strategies are evaluated using power system simulations for a typical low voltage residential feeder network in Ireland. Results show that by using the proposed AIMD based smart charging algorithms 50% EV penetration can be accommodated, compared to only 10% with uncontrolled charging, without exceeding network infrastructure constraints.

**Key words:** smart grid; electric vehicle charging; AIMD; distributed control;

## 1. Introduction

In recent years with government policy incentivizing sustainable society developments and rapid technological advances by the automotive industry, electric vehicles (EVs) are increasingly being prioritized as a means of reducing pollution, combating climate change and improving energy security. Many countries have set ambitious targets for EV penetration. The Irish Government, for example, has set a target of 10% for the penetration of EVs in Ireland by 2020 (Foley *et al.*, 2011). China is targeting 20% - 30% EV penetration by 2030. Similarly, Europe is aiming to have 48 million EVs on the road by 2015 while the US has set a target of 100 million for the same time frame (IEA, 2011).

---

**Address for correspondence:** Mingming Liu, Hamilton Institute, NUIM, Maynooth, Ireland. E-mail: mliu@eeng.nuim.ie

---

Electric vehicles can generally be classified as being either battery electric, battery and combustion engine hybrids or fuel cell based (Lopes *et al.*, 2011). Among these, battery electric vehicles (BEVs) and hybrids electrical vehicles (HEVs) obtain their energy by plugging into the electricity grid and are collectively referred to as plug-in EVs (PEVs), with hybrids typically referred to as PHEVs. PHEVs have become a very popular topic for research and development since 2007 (Shao *et al.*, 2009) due to their potential to overcome the range anxiety adoption barrier associated with BEVs. However, as battery capacities continue to grow BEVs are also likely to be widely adopted (Khan and Kockelman, 2012; SEAI, 2007).

From a power systems perspective a major concern is that, as an increasing number of EVs plug into the grid in residential areas, if charging is not regulated it is likely that coincident uncontrolled charging of EVs will overload local distribution networks and substantially increase peak power requirements (Qian *et al.*, 2011; Clement-Nyns *et al.*, 2009). Not surprisingly therefore, developing smart grid infrastructure and charging strategies to mitigate the impact of the role out of EVs on the grid have been the focus of considerable research effort in recent years (Qian *et al.*, 2011; Sortomme *et al.*, 2011; Richardson *et al.*, 2012a). Clement-Nyns *et al.* (2011) have proposed a coordinated charging method which seeks to minimize power losses and maximize the main grid load factor. A technique employing linear programming to determine the optimal EV charging rate was investigated in Richardson *et al.* (2012b) as a means of maximizing the total power that can be delivered to EVs while meeting distribution network constraints. In Clement-Nyns *et al.* (2009) a coordinated charging algorithm using both quadratic and dynamic programming was developed to shift EV loads to off-peak times while minimizing the power losses for both deterministic and stochastic data. In Galus *et al.* (2011) a transportation micro-simulation was employed to secure power system operation using a multi-agent system (MAS) to coordinate EV charging behavior. In Fan (2012), to maximize a customer's own utility, a simple adaption strategy based on price feedback was effectively used to solve the distributed EV charging problem in the smart grid. Most recently, Stüdl *et al.* (2012a, 2012b) have proposed charging strategies based on Additive Increase and Multiplicative Decrease (AIMD) algorithms that can be implemented in a decentralized fashion to maximize power utilization by EVs while achieving a fair allocation of power across customers.

The major advantages offered by AIMD over the other approaches proposed to date are its low computational complexity and minimal communication requirements. However, the basic AIMD implementation considered in Stüdl *et al.* (2012a, 2012b) only considers the operation of the algorithm from the perspective of the consumer and the fair distribution of available power. Practical power system infrastructure and operating constraints were not considered. In this paper, which is an extended version of Liu and McLoone (2012), we propose a number of enhancements to the basic AIMD charging algorithm that take account of the power system structure, mitigate the impact of EVs on the grid from the perspective of transformer loading levels and voltage profiles, and reduce peak power requirements by responding to time-of-day pricing. Using a custom OpenDSS-Matlab simulation platform, the enhanced AIMD

implementations are evaluated for a typical low-voltage residential feeder network with 50% EV penetration.

The remainder of the paper is structured as follows. Section 2 provides an overview of the decentralized AIMD charging strategy proposed by Stüdl *et al.* (2012a, 2012b). Section 3 then introduces the proposed enhanced AIMD algorithm implementation and sets out the underpinning assumptions for its applicability. Section 4 describes the simulation test bed and distribution network model employed in our simulations. Then in Section 5 results of our simulation studies are presented and discussed and finally, conclusions are presented in Section 6.

## 2. Decentralized AIMD charging

The basic idea of AIMD was originally applied in the context of decentralized congestion control in communication networks (Shorten *et al.*, 2006). Stüdl *et al.* (2012a, 2012b) proposed applying AIMD to EV charging problems and investigated a number of practical scenarios including domestic charging of EVs. In this scenario each active domestic EV charge point executes the following basic decentralized AIMD algorithm (Figure 1).

---

```

while battery not charged do
  if capacity event then
    generate uniform random number,  $p$ 
    if  $p < p_i$  then
       $c_i(k + 1) = \beta^{(1)} \cdot c_i(k)$ 
    else
       $c_i(k + 1) = \beta^{(2)} \cdot c_i(k)$ 
    end if
  else
     $c_i(k + 1) = c_i(k) + \alpha \cdot \Delta T$ 
  end if
end while

```

---

**Figure 1** Basic decentralised AIMD smart charging algorithm

Here,  $c_i(k)$  is the charge rate of the  $i$ th EV at time instance  $k$ ;  $\alpha$  is an additive constant value in kW/s;  $\beta^{(1)}, \beta^{(2)}$  are multiplicative constants, which are selected at random with probability  $p_i$ , and  $\Delta T$  is the time interval between EV charge rate updates. Thus, during operation each EV charge point additively increases its charge rate until a “capacity event” occurs at which point it applies a multiplicative decrease to the charge rate. A capacity event is deemed to have occurred when the total power  $P(k)$  demanded by all active EV charger points at time instance  $k$  exceeds the maximum available power  $\bar{P}(k)$  at that time instant. Here  $P(k)$  is computed as

$$P(k) = \sum_{i=1}^{N(k)} c_i(k) \quad (1)$$

where  $N(k)$  is the number of active chargers at the  $k$ th time instant. In the decentralised AIMD framework proposed by Stüdl *et al.* (2012a, 2012b) the  $P(k) < \bar{P}(k)$  capacity event condition is monitored by a central monitoring station (server) at the main distribution network substation which broadcasts a message to the charge points when events occur. Thus, the decentralised AIMD approach assumes a simple radial communication topology, as depicted in Figure 2, with each EV charge point equipped with a communication device that is able to receive signals broadcast by the central monitoring station.

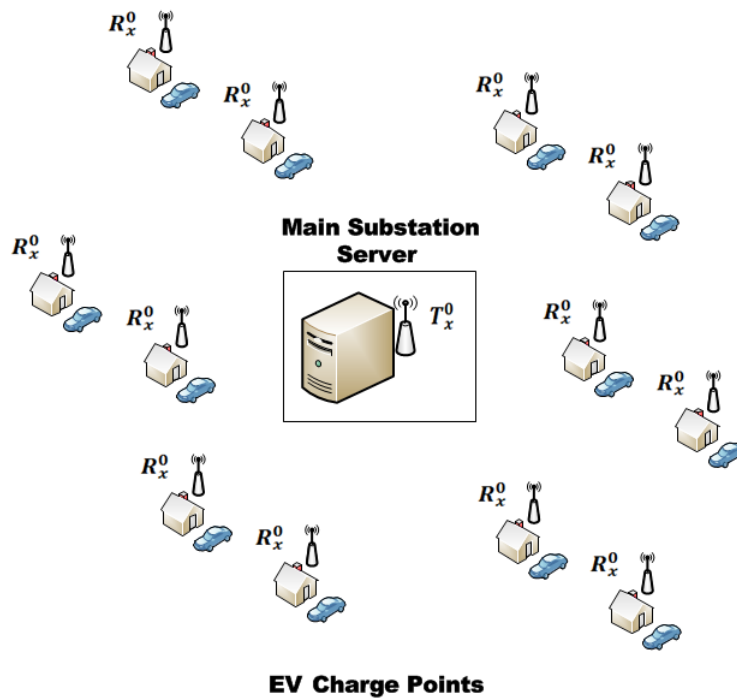

**Figure 2** Decentralised AIMD smart charging communication topology

As discussed in Stüdl *et al.*, (2012b), the key characteristic of the AIMD algorithm is that it guarantees an equitable ‘average’ distribution of the available power between active EV charge points if each charge point chooses the same  $\alpha, \beta$  and  $p$ , parameters. The elegance of the approach is that it achieves this desirable property while requiring a minimum of communication infrastructure and only limited computing capabilities on each EV. In addition, the simple communication topology and minimal communication bandwidth make it a highly scalable and cost effective solution.

---

### 3. Enhanced AIMD smart charging strategy

As already noted, practical power system infrastructure and operating constraints were not considered in the decentralized AIMD EV charging strategy investigated by Stüdl *et al.*, (2012a, 2012b), rather the focus was on developing a charging strategy that distributes available power fairly between customers in a variety of user orientated charging scenarios (e.g. domestic, workplace, motorway service station, shopping mall and parking area charging). In this section we introduce a number of enhancements to the basic decentralized AIMD EV charging method so that power system constraints on voltages and infrastructure loading are taken into account. In addition, we modulate the available power signal in response to a varying electricity price (CER 2009; SEAI 2012) to affect a shift in EV loads away from periods of high demand, thereby reducing peak-power capacity requirements and ultimately the cost to the consumer. The overall objective is to achieve benefits for both utilities and customers with all EVs sharing the maximum amount of available power fairly while ensuring that the distribution network continues to operate within acceptable limits.

#### 3.1 Assumptions

We make several assumptions with regard to EVs and the residential EV charging infrastructure, which are consistent with previous studies in (Richardson *et al.*, 2010, 2012b; Stüdl *et al.*, 2012a, 2012b; Galus *et al.*, 2011). The assumptions are as follows:

- (i) All EV batteries have a capacity of 20 kWh.
- (ii) Each EV charger is connected to a standard household outlet at 230V.
- (iii) The maximum power output from the EV home charger cannot exceed 3.7kW.
- (iv) Each EV has the ability to adapt its charge rate in real-time and continuously.
- (v) Power flow for EV charging is unidirectional from grid to vehicle (i.e. vehicle-to-grid is not considered).

#### 3.2 Communication topology and infrastructure requirements

In order to incorporate power system constraints into the decentralized AIMD charging algorithm in a practical and scalable way a hierarchical communication topology paralleling the topology of the grid is proposed, as shown in Figure 3. The complexity of the communication and charger infrastructure required depends on the power system constraints that are taken into account.

At its simplest the AIMD algorithm only requires the broadcasting capability of the main substation sever and the receiving capability of each EV charger as envisaged by Stüdl *et al.*, (2012a, 2012b) and depicted in Figure 2. However, equivalently, this can be implemented in a cascaded fashion as shown in Figure 3 with the central monitoring station at the main distribution substation relaying its generation capacity event broadcasts to the local distribution substations, which in turn relay the broadcast to the EV charge points in their local area.

An advantage of this hierarchical approach is that it reduces transmitter power requirements and can take advantage of existing communication infrastructure that typically exists on the transmission network. More importantly, it offers the possibility of responding to local infrastructure capacity events such as overloading of a substation transformer. To enable this each substation has to have a local monitoring station (substation server) to receive generation capacity event broadcasts from the central monitoring station (main substation server), detect local infrastructure capacity events and broadcast capacity event information to the charge points in its area. It should be noted that since the AIMD algorithm does not distinguish between capacity event types no modifications are required to the EV charge points to accommodate infrastructure capacity events.

However, this is not the case for line voltage events. Since line voltage issues are inherently local to the user, they cannot be detected at the local substation. Instead they have to be sensed by the individual EV charge points and the information relayed back to the local substation. Therefore, in order to respond to voltage events each EV charger needs to have the capability to continuously sense its own socket voltage and transmit a voltage event message to its local substation when the voltage drops below an acceptable level.

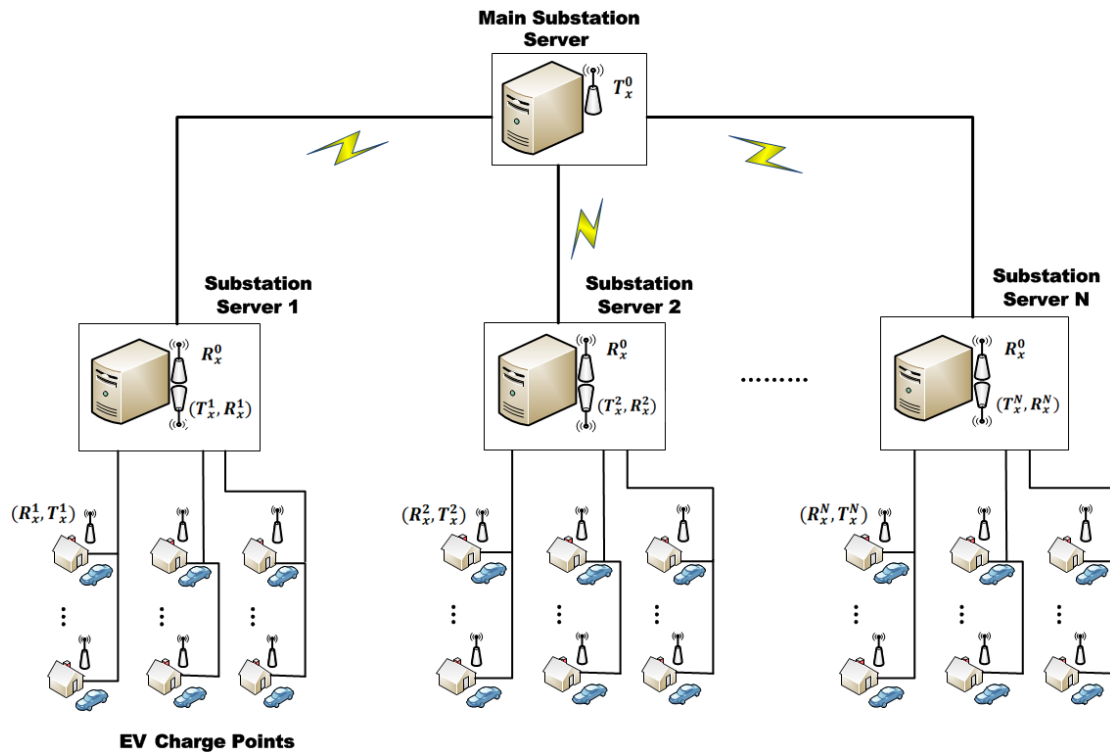

**Figure 3** Communication topology for the Enhanced AIMD implementation

### 3.3 Enhanced AIMD algorithm

With the appropriate communication and sensing infrastructure in place, as outlined above, the basic AIMD smart charging algorithm running on each charge point can be

modified to respond to voltage, infrastructure and generation capacity events as shown in Figure 3. Here,  $V_i(k)$  is the line voltage of the  $i$ th EV charge point at the  $k$ th time instant,  $V_{event}$  is a threshold voltage level below which a voltage event is triggered and voltage event message transmitted to the local substation server, and  $V_{min} < V_{event}$  is the minimum acceptable voltage level below which the EV charger enters a protective self regulation mode. The remaining parameters are as defined previously for the basic AIMD implementation.

---

```

while battery not charged do
  if capacity event then
    generate uniform random number,  $p$ 
    if  $p < p_i$  then
       $c_i(k + 1) = \beta^{(1)} \cdot c_i(k)$ 
    else
       $c_i(k + 1) = \beta^{(2)} \cdot c_i(k)$ 
    end
  else
     $c_i(k + 1) = c_i(k) + \alpha \cdot \Delta T$ 
  end if
  if  $V_i(k) < V_{event}$ 
    transmit voltage event message
  end if
  if  $V_i(k) < V_{min}$  (self regulation)
     $c_i(k + 1) = 0$ 
  end if
end while

```

---

**Figure 4** Enhanced decentralised AIMD smart charging algorithm

The local monitoring station for a given residential area broadcasts a capacity event signal to the active EV charge points in its area if any of the following conditions are satisfied:

- (i) A generation capacity event is broadcast by the main substation
- (ii) A voltage event message is transmitted by any of the charge points in its residential area
- (iii) A local infrastructure constraint violation is detected (e.g. transformer overload)

In addition to monitoring infrastructure constraints, the central monitoring station at the main substation is responsible for determining the power available and broadcasting a generation capacity event when this is exceeded. The total instantaneous power consumption is given by



$$P(k) = \sum_{j=1}^N h_j(k) + \sum_{i=1}^{N(k)} c_i(k) , \quad (2)$$

where  $h_j(k)$  represents the non-EV power consumption for the  $j$ th house on the distribution network at time  $k$ ,  $c_i(k)$  is the charge rate of the  $i$ th active EV charge point,  $N$  is the number of houses on the distribution network and  $N(k)$  is the number of active charge points. The instantaneous available power is computed as

$$\bar{P}(k) = P_{rated} - \lambda . \quad (3)$$

Here  $P_{rated}$  (kVA) is the maximum capacity that can be drawn from the substation and is the lesser of the available generation capacity or the substation rating, while  $\lambda$  (kVA) is a constant ‘safety margin’ for secure operation.

Compared to the basic AIMD EV charging strategy which provides a globally fair charging solution in response to central generation capacity events, the Enhanced AIMD implementation introduces a locally fair charging solution which offers greater protection to the grid infrastructure and optimum usage of available power. For example, if one of the local transformers is overloaded but overall generation capacity is not being exceeded at the main substation, the basic AIMD implementation would fail to respond, while the enhanced implementation will decrease only the charge rates of the EVs in the corresponding local area to protect the transformer. A globally fair charging solution in these circumstances would require that charge rates of EVs in unaffected areas also be reduced, but this would lead to under utilization of available generating capacity.

While responding to voltage constraint violations within the AIMD framework adds substantially to the complexity of EV charge point infrastructure the local sensing of voltage at each EV allows a degree of self-regulation/fail-safe mode to be introduced whereby each EV switches off whenever the detected line voltage drops below a minimum acceptable level,  $V_{min}$ , irrespective of whether a capacity event has been received or not (as implemented in Figure 4). Since severe generation capacity and infrastructure overloading events generally cause significant voltage issues, this offers a degree of robustness to communication system failures. This self regulation mode violates the conditions for locally fair charging, but provided there is a sufficient margin between  $V_{min}$  and  $V_{event}$  it will only rarely be activated.

### 3.4 Price-adjusted available power

AIMD is inherently an instantaneous algorithm with no temporal visibility hence it cannot take a longer term view in determining EV charge rates. However, a simple heuristic modification can be introduced to the available power calculation that allows the temporal context to be taken into account in a meaningful way with negligible impact on overall system complexity. The heuristic is to modulate the available power

signal  $P(k)$  with time-of-use pricing information so that an artificial reduction in available power is created at times of high electricity prices, that is:

$$\bar{P}(k) = P_{rated} - \lambda - (E(k) - E_{min}) \cdot \xi. \quad (4)$$

Here  $\xi$  is a constant tuning parameter,  $E(k)$  (cent/kWh) is the Time-of-Use (TOU) price at time  $k$  and  $E_{min}$  is the minimum TOU price during the day. Since the TOU prices reflect the peak demand periods on the grid, this modification essentially drives EV load to off-peak times. To implement price-adjusted AIMD charging the only additional requirement is that TOU pricing information be made available to the central monitoring station. Where this information is pre-defined and fixed (SEAI, 2012), it can be pre-programmed into the central monitoring station software. Otherwise it can be periodically relayed to the station via a communication link.

## 4. Simulation platform

### 4.1 Distribution network

To evaluate the performance of the proposed enhancements to the basic AIMD charging strategy a test distribution network incorporating EVs is simulated based on a typical LV residential feeder layout. A simplified schematic diagram for the test network is given in Figure. 5. In our simulations, the voltage is set at 1.0pu at the source end of the external grid. A 2MVA distribution substation is connected to the external grid to bring the voltage level to 10kV. This substation feeds three local substations / distribution transformers (e.g. pole-mounted distribution transformers) serving residential areas. Each distribution transformer is connected by an unbalanced transmission line of different length (modeled as Pi-Equivalent circuits). Both household loads and EV charging loads are connected at the secondary side of each distribution transformer. As illustrated in Figure 5, the household loads with EV charging points are separated into three phases, and the number of houses connected to each phase is indicated in parenthesis. Non-EV charging loads are lumped together using balanced three phase modeling. The distance between each house connected to a given phase is randomly chosen between 10-50m. Further details of the transmission line parameters can be found in Appendix A.

To simulate EVs connecting to this network and charging over a period of time a custom OpenDSS-Matlab simulation platform was developed. OpenDSS (EPRI 2010), an open source electric power Distribution System Simulator, was used to simulate the power system and calculate the instantaneous power flows and voltage profiles for the test network. Matlab was used to simulate typical residential EV connection, SOC and disconnection patterns (randomly generated for each EV) and to create a wrapper programme to simulate the operation of the network over a period of time for varying household and EV loads. The main steps performed by the wrapper programme are summarized in Figure 6. Here  $N_{sim}$  denotes the number of time steps in the

simulation and is simply the duration of the simulation  $T_{sim}$  divided by the sampling interval  $\Delta T$ .

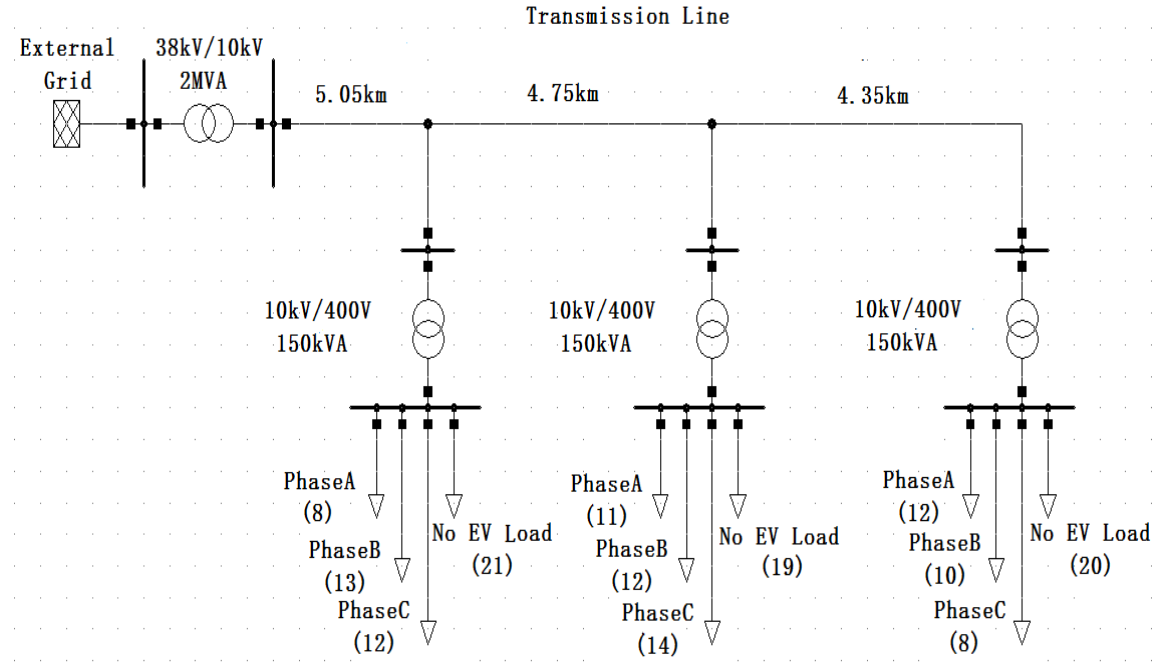

**Figure 5** Schematic diagram of the distribution network

---

**for**  $k = 1, 2, \dots, N_{sim}$

- (i) Determine the set of EVs ( $i = 1, 2, \dots, N(k)$ ) currently connected to the grid (based on a simulation of typical residential EVs connection and disconnection patterns)
- (ii) For each EV compute its instantaneous charge rate,  $c_i(k)$ , according to the selected AIMD algorithm
- (iii) For each household ( $i = 1, 2, \dots, N$ ) generate its current non-EV load,  $h_i(k)$
- (iv) Generate an updated OpenDSS simulation parameters file
- (v) Call the OpenDSS software to simulate the current state of the distribution network
- (vi) Record the current values of relevant EV and distribution network states (connection status, SOC, line voltages, substation power flows etc.)

**end for**

---

**Figure 6** OpenDSS-Matlab Wrapper Programme for EV charging simulation

## 4.2 Residential power consumption profiles

In our simulation study we consider a typical Irish grid residential distribution network over a 72 hour period for both summer charging and winter charging scenarios. Residential power consumption profiles for these scenarios were generated based on residential customer smart meter electricity trial data provided by the *Commission for Energy Regulation (CER)* in Ireland (CER 2012). This consisted of time series demand data for 4225 residential customers over 536 days, sampled every 30 minutes starting from 15<sup>th</sup> of July 2009. The non-EV household load profiles for each of the 160 houses in our test network were generated by randomly selecting load profiles from the CER dataset and upsampling them using linear interpolation to the desired sampling interval  $\Delta T$ . Summer scenario profiles were generated from the period 22<sup>nd</sup> of July to 24<sup>th</sup> of July 2009 and the winter profiles we generated from the period 22<sup>nd</sup> of January to 24<sup>th</sup> of January 2010. For ease of consideration, the power factor of each household load is set to a fixed value of 0.88 lagging. A comparison diagram of the average load consumption for 4225 residential smart meters during both periods is shown in Figure 7. As expected this shows that the average power consumption during typical Irish winter days is much higher than during summer days. In particular, the peak power consumption during the three winter days is more than 50% greater than the summer peaks.

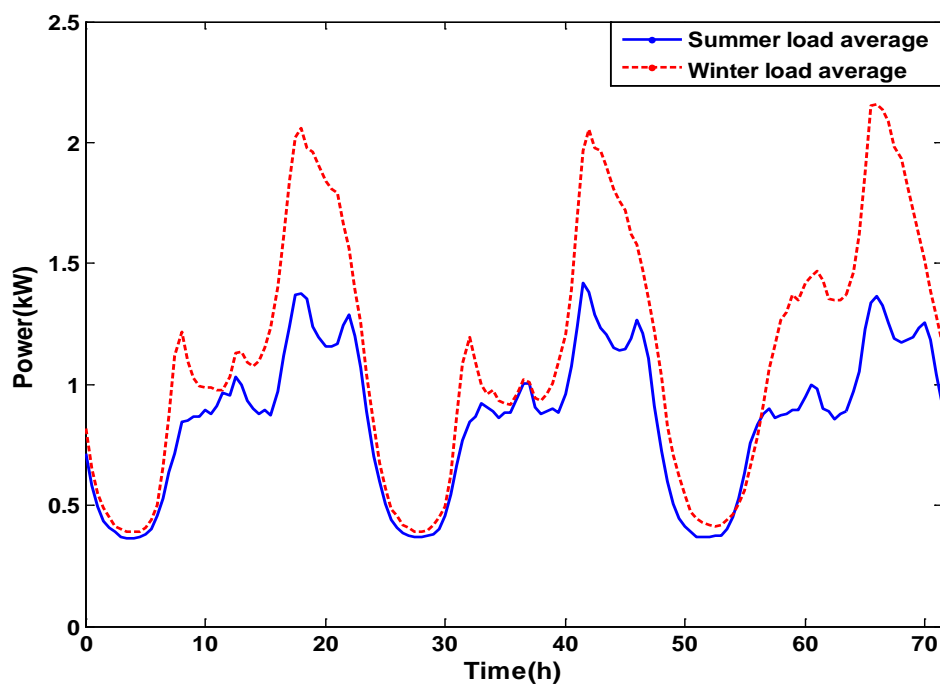

**Figure 7** Average summer and winter residential power consumption profiles in Ireland as computed from smart meter trial data of 4225 customers (CER 2012)

## 4.3 EV connection and SOC patterns

Analysis of Irish traffic survey data (CSO 2009) reveals that the majority of

commuters arrive home between 4pm-8pm each day. To model this in our simulation EV home arrival times are generated from a normal distribution centered at 6 pm with a standard deviation of 1 hour. It should be noted that the mean home arrival time falls during the time interval normally associated with peak-power on the Irish grid (5pm to 7pm), hence unregulated EV charging has the potential to substantially increase peak-power requirements on the grid.

The initial state of charge (SOC) of each EV at plug-in is also selected randomly from a uniform distribution over the interval 5kWh to 15kWh. EVs are assumed to remain connected to the grid overnight and disconnect only when fully charged.

#### 4.4 Simulation parameters

For our AIMD algorithm implementations  $E_{min}$  and  $E(k)$  are set in accordance with the TOU pricing employed in the aforementioned smart meter trials, (CER 2009, SEAI 2012),  $\xi = 12$ ,  $P_{rated}$  is set to 450kVA and  $\lambda = 50$ kVA. The voltage event threshold  $V_{event}$  is set as 0.92pu and  $V_{min}$  is selected as 0.9pu, which is the minimum acceptable voltage level in Ireland (ESB 2007), and the capacity limit and safety margin for each distribution transformer is set as 150kVA and 20kVA, respectively. Charging is performed in accordance with the assumptions set out in Section 3.1. We also assume that each EV is automatically disconnected from the grid when it is fully charged and that the power factor of EV loads is 1.0pu. This is consistent with the assumptions made in Richardson (2012b).

Updates are performed every 5 minutes (i.e.  $\Delta T = 300$  s). This value was selected as a compromise between temporal resolution and simulation computational complexity. In practical deployments, to achieve satisfactory response times to time-critical generation capacity and voltage events update rates of less than 1 second are needed. It is also feasible to implement the AIMD based charging algorithms so that they respond instantaneously to voltage and capacity events while adhering to a more modest fixed update interval for the additive step of the algorithm.

For convenience, while simulations are performed over 3 day periods starting at midnight on the first day ( $t=0$ ), EV charging is only implemented for the complete charging cycles which occur between days 1 and 2 and days 2 and 3.

## 5. Results

Utility companies hope that in the short to medium term (10-20 years) smart charging strategies will enable them to accommodate the extra loads represented by EV charging without needing to upgrade their distribution network infrastructure. To predict the impact of EV charging on the grid we assume a maximum penetration of EVs of 50% in the medium term and simulate the operation of the local both distribution network under these circumstances for various charging scenarios for summer and winter grid loads. The charging scenarios considered are uncontrolled charging (UnCtrl), the basic AIMD algorithm (AIMD-G) proposed by Stüdl *et al.*, (2012a, 2012b) and a number of enhanced AIMD implementations introduced in this

paper namely:

- AIMD charging with generation and local infrastructure capacity events handling (AIMD-GI);
- price-adjusted AIMD charging with generation and local infrastructure capacity events handling (AIMD-GIP);
- AIMD charging with generation capacity, local infrastructure capacity and line voltage events handling (AIMD-GIV);
- price-adjusted AIMD charging with generation capacity, local infrastructure capacity and line voltage events handling (AIMD-GIVP);

Table 1 provides a summary comparison of the performance of each of these strategies in terms of their impact on the grid and on the consumer. For completeness the metrics for the grid without EVs are also shown (NoEV). To facilitate direct comparison between each charging strategy for both winter and summer scenarios all simulations were performed using the same (randomly generated) EV initial State of Charge (SOC) and plug-in times.

TABLE 1  
COMPARISON OF ALL TESTED SCENARIOS CONSIDERED

<i>Scenarios</i>	<i>Minimum voltage (p.u)</i>	<i>Maximum Load (%)</i>	<i>Max. Local Infrastructure Load (%)</i>	<i>Duration of voltage dips (min.)</i>	<i>Average Cost (cents/kWh)</i>	<i>Average charge rates (kW)</i>
<b><u>Summer</u></b>						
NoEV	0.9280	64.37	74.08	0	-	-
UnCtrl	0.8868	117.57	115.83	80	19.47	3.70
AIMD-G	0.8950	99.56	96.16	10	14.02	2.05
AIMD-GI	0.9025	98.36	89.95	0	13.72	1.98
AIMD-GIP	0.9133	91.51	92.65	0	11.68	1.66
AIMD-GIV	0.9134	97.37	90.49	0	13.61	1.90
AIMD-GIVP	0.9170	91.38	89.74	0	11.66	1.64
<b><u>Winter</u></b>						
NoEV	0.9015	104.08	102.15	0	-	-
UnCtrl	0.8630	156.94	145.74	320	19.47	3.70
AIMD-G	0.8940	110.21	108.59	65	12.20	1.47
AIMD-GI	0.8990	109.79	103.70	25	11.88	1.45
AIMD-GIP	0.8996	104.92	102.39	10	10.78	1.42
AIMD-GIV	0.9006	109.33	103.46	0	11.89	1.44
AIMD-GIVP	0.9010	104.89	102.36	0	10.75	1.38

*Note: **Maximum Load:** Maximum loading as a percentage of the main substation rating (400kVA); **Max. Local Infrastructure Load:** Maximum local infrastructure (i.e. distribution transformer) loading as a percentage of infrastructure rating; **Duration of voltage dips:** Total time in minutes over the 3 days that the voltage drops below 0.9pu; **Average cost:** Average charging cost per kWh; **Average charge rates:** Average charge rates of all active EVs over two days.*

The charging strategies listed in Table 1 are essentially in order of increasing sophistication, and not surprisingly the results reflect a corresponding increase in performance with the best results obtained with the price-adjusted AIMD smart charging algorithm (AIMD-GIVP). To complement the results in the Table a series of plots are provided for this algorithm as follows. Figures 8 to 10 show the voltage profiles, transformer power flows and main substation power flow obtained for the summer scenario. The corresponding plots for the winter scenario are given in Figures 11 to 13. In each case the plots for No EVs on the grid and uncontrolled charging are included for comparison. The daily price variation signal  $E(k)$  employed with AIMD-GIVP and AIMD-GIP is plotted in Figure 14. This is also the price information used for calculating the average cost of charging with each strategy reported in Table 1. Finally, Figure 15 provides a comparison of the EV load profile obtained using AIMD-GIV and AIMD-GIVP.

### 5.1 Uncontrolled charging

Uncontrolled charging, also known as uncoordinated charging or opportunistic charging, is where each EV begins charging at the maximum rate once it is plugged in and continues charging at this rate until fully charged. The minimum non-EV voltage on all buses during the summer peak-periods was found to be 0.93pu. With uncontrolled EV charging coinciding with peak-power several bus voltages drop to 0.89pu. The power flows at the substation and distribution transformers are marginally overloaded during peak-times as a result of EV charging and the demanded power exceeds the available power at the main substation by 18%.

The simulation results show that the impact of uncontrolled EV charging is much greater in the winter scenario with greater voltage sags (0.86 pu), increased overloading of transformers and demanded power exceeding the available power by 57%. Thus, for our test distribution network uncontrolled charging at 50% EV penetration cannot be supported. Simulations conducted for different EV penetration levels (not included) show that the maximum level that can be sustained under these conditions is 10%.

### 5.2 Enhanced AIMD Smart charging

From a grid infrastructure perspective the inclusion of generating (G), infrastructure (I) and voltage (V) constraints has the desired effect of mitigating the impact of EV charging on the grid. Maximum loading is reduced relative to uncontrolled charging with available power being fully utilized when spare capacity exists relative to the residential load (98-99% loading during the summer). In the winter the maximum load is exceeded even when there are no EVs on the grid, hence the target of 100% cannot be achieved. However, the maximum load is driven towards the minimum achievable level of 104%. A similar pattern is observed with the local infrastructure loading. The fact that the minimum achievable loading levels are not reached is simply a consequence of the need for a capacity event threshold to be exceeded in

order for AIMD to respond, coupled with the relatively slow response times employed in the simulation study (determined by the multiplicative constants,  $\beta^{(1)}, \beta^{(2)}$  and the update interval  $\Delta T$ ). However, this is not a limitation of the approach as rapid response times can be obtained in a number of ways, as discussed in Section 4.4.

From a consumer perspective the quality of service in terms of the maintenance of voltage levels is important, and this also improves with increasing sophistication of charging strategies. For example, in the winter scenario the minimum voltage on the grid with AIMD-G, AIMD-GI and AIMD-GIV smart charging is 0.8940pu, 0.8990pu and 0.9006pu, respectively, compared to 0.86pu with uncontrolled charging. More importantly, the duration of the voltage dips experienced by consumers, which amounts to 320 minutes with uncontrolled charging, is substantially reduced using AIMD-G (65 minutes) and AIMD-GI (25 minutes) and eliminated completely with AIMD-GIV.

A further benefit to the consumer of employing the enhanced AIMD algorithms is that the average cost of charging is also reduced. However, it should be noted that this is an indirect consequence of AIMD adapting to the imposed G, I and V constraints and not a deliberate objective of the algorithm. AIMD is purely focused on distributing available power fairly regardless of price. This is evident from the fact that the average cost of charging with AIMD is more expensive in the summer than in the winter even though the total demand for power on the grid is much greater in the winter. The reason for this is that, due to the lower household demand in the summer (Figure 7), there is much greater availability of power for EV charging during the peak-price period and this typically coincides with the period when most EVs plug-in for charging.

### 5.3 Price adjusted charging

Employing the price-adjustment mechanism explicitly attempts to shift load to off-peak times on the basis that high prices equate to peak load. Its effectiveness is clearly evident when comparing the power flows for uncontrolled and AIMD-GIVP smart EV charging in Figures 9, 10, 12 and 13. In the summer scenario, in particular, the peak power has been postponed from 6 pm until after 9 pm, reflecting a corresponding shift in the EV charging load. This is further highlighted in Figure 15, which shows a comparison of the EV load profile obtained using AIMD-GIV and AIMD-GIVP.

In general, the overall performance of all AIMD implementations is improved substantially when the price adjustment heuristic is included (compare AIMD-GI with AIMD-GIP and AIMD-GIV and AIMD-GIVP in Table 1). From Table 1 it is also noteworthy that AIMD-GIP provides comparable performance to AIMD-GIV and thus is an attractive proposition if the added expense and complexity required to implement AIMD-GIV is an issue.

Not surprisingly, price adjusted AIMD implementations also result in the lowest charging costs for consumers, by virtue of directly limiting the amount of charging that takes place at peak-price times. However, since reducing the cost to the consumer was not an explicit objective of the heuristic, its parameters were not adjusted



accordingly, and hence charging costs in the summer remain higher than in the winter with both AIMD-GIP and AIMD-GIVP. Practically, the price-adjustment mechanism can be modified to ensure that no charging takes place during peak price periods in either the summer or winter by adapting  $\xi$  to track seasonal demand, thereby ensuring consistent cost reductions all year round.

A potential weakness of modulating available power by TOU pricing information is that it assumes a correspondence between price and peak loading, which is not necessarily guaranteed. However, there is no restriction on the choice of modulating signal that can be employed with AIMD. The available power signal can easily be adjusted in response to a real-time pricing signal or any other signal that reflects periods of stress on the grid, so long as the signal is available at the central monitoring station. Hence, the AIMD framework offers the possibility of fairly shedding discretionary load to improve system security (demand side management).

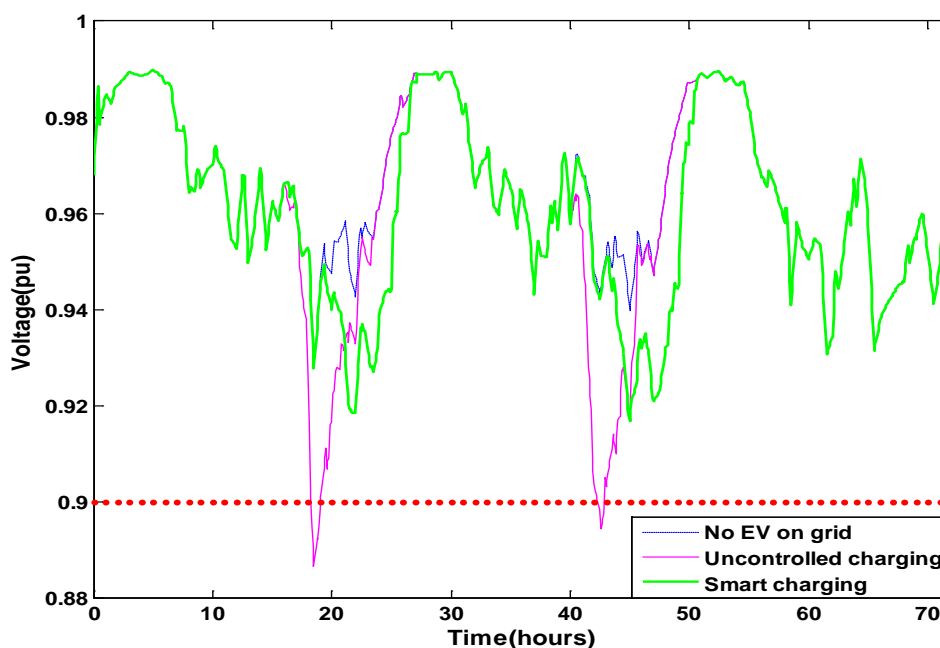

**Figure 8** Minimum voltage level on residential area buses with and without EV charging superimposed (AIMD-GIVP smart charging, summer scenario)

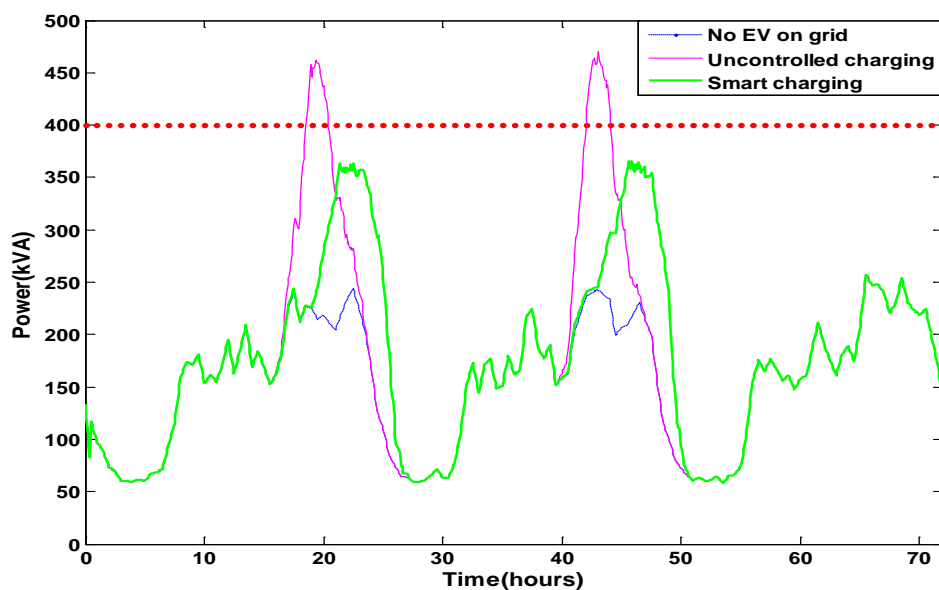

**Figure 9** Main Substation power flow with and without EV charging superimposed (AIMD-GIVP smart charging, summer scenario)

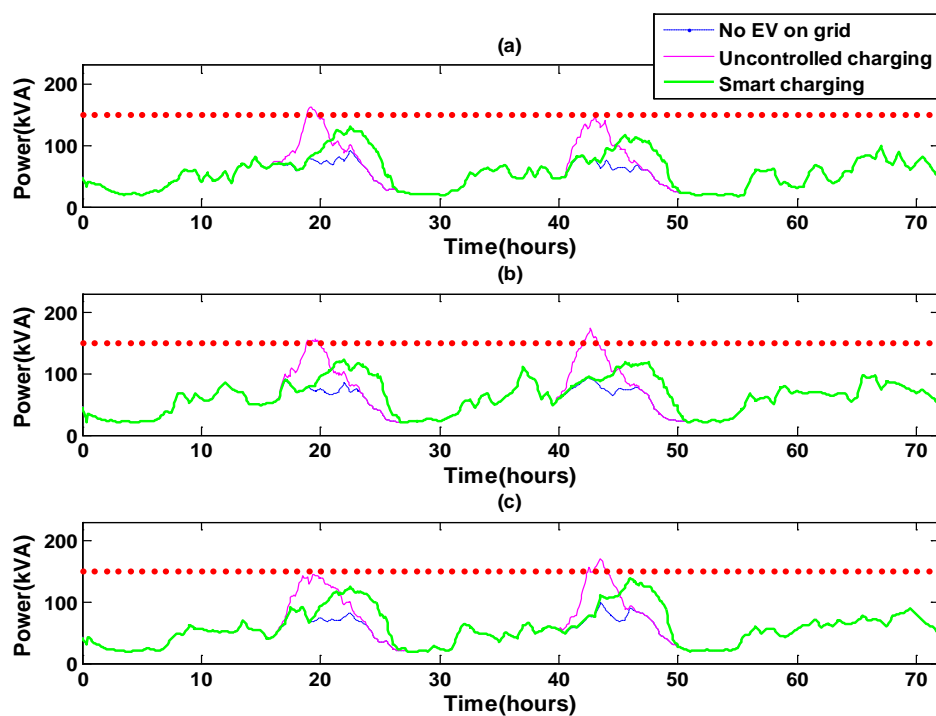

**Figure 10** Distribution transformer power flows with and without EV charging superimposed (AIMD-GIVP smart charging, summer scenario): (a) residential area A; (b) residential area B; (c) residential area C.

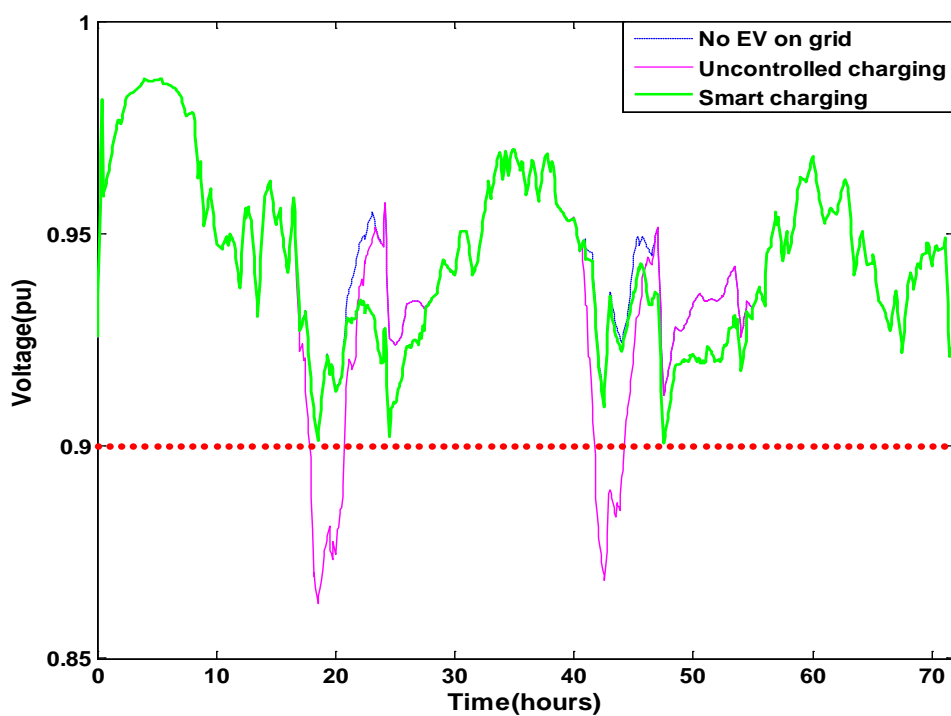

**Figure 11** Minimum voltage level on residential area buses with and without EV charging superimposed (AIMD-GIVP smart charging, winter scenario)

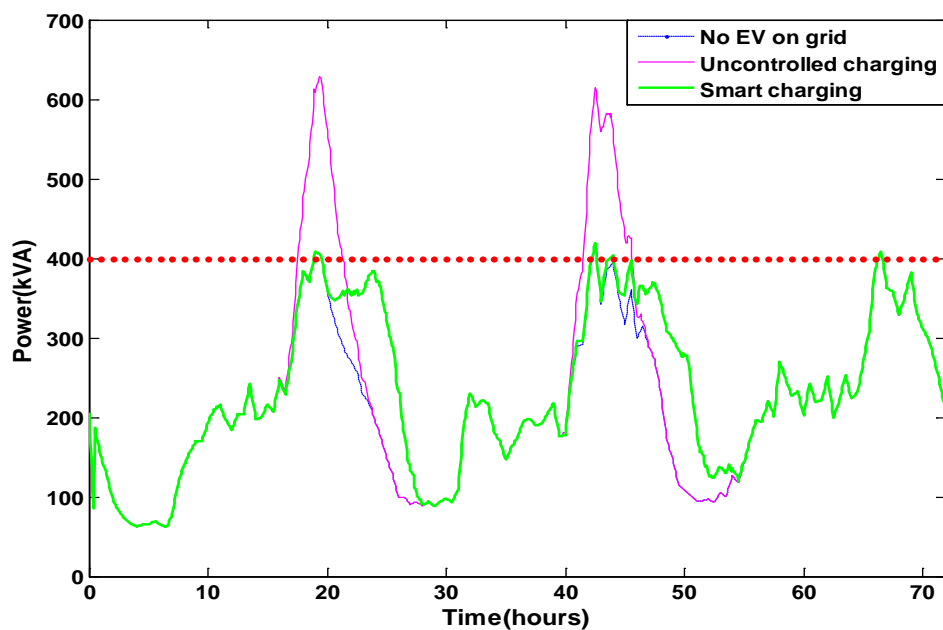

**Figure 12** Substation power flow with and without EV charging superimposed (AIMD-GIVP smart charging, winter scenario)

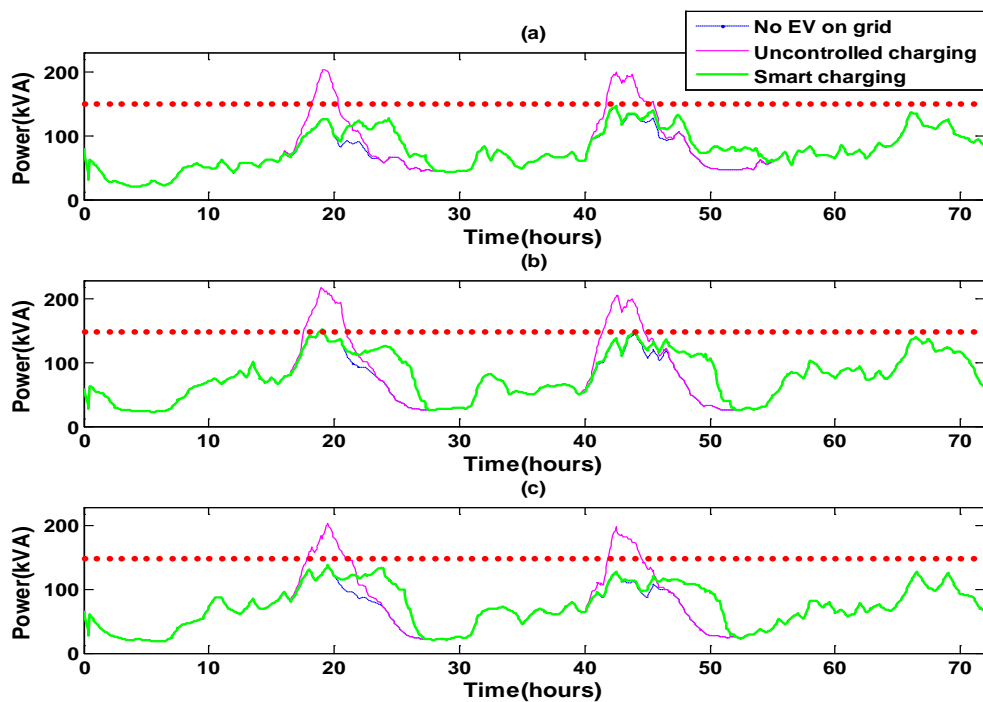

**Figure 13** Distribution transformer power flows with and without EV charging superimposed (AIMD-GIVP smart charging, winter scenario): (a) residential area A; (b) residential area B; (c) residential area C.

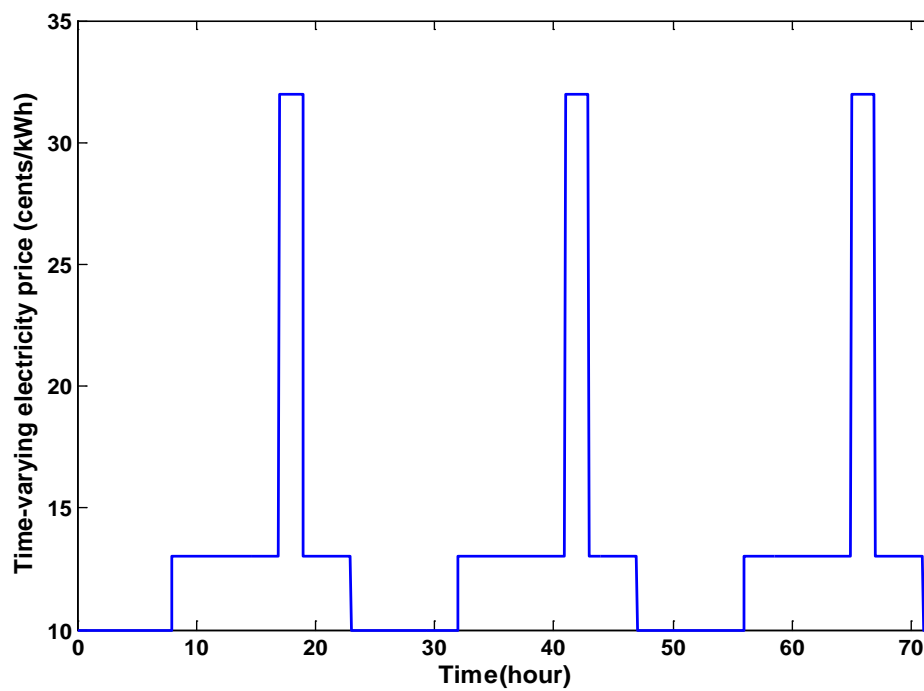

**Figure 14** Plot of the TOU electricity price signal  $E(k)$

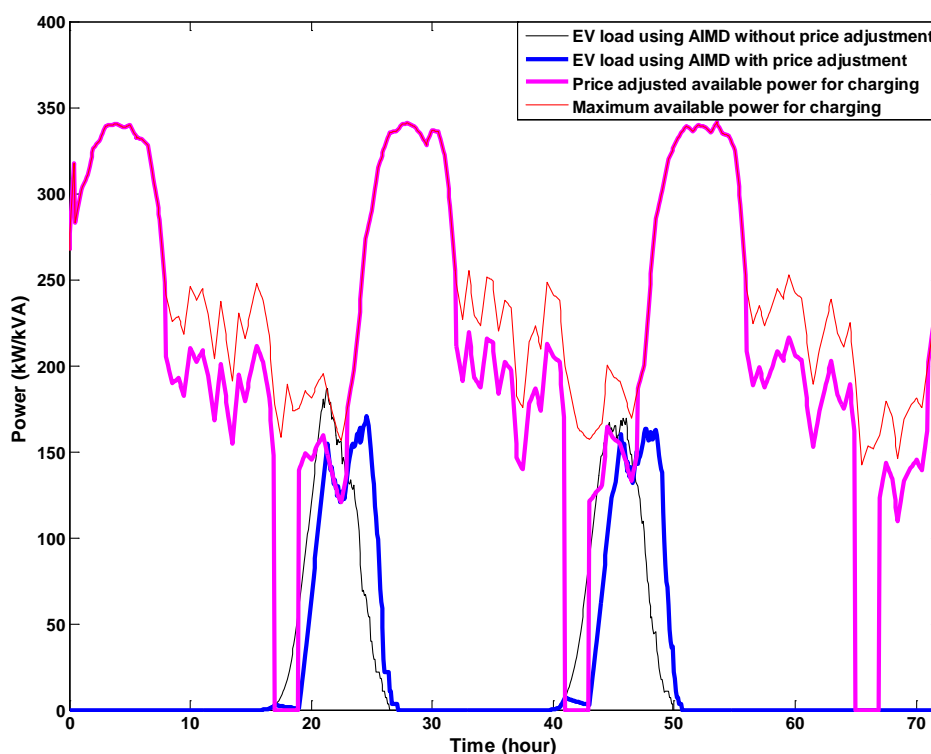

**Figure 15** Comparison between EV loads obtained using Enhanced AIMD smart charging with and without price adjusted available power (summer scenario).

## 6. Conclusions

A number of novel enhancements to the basic AIMD EV charging algorithm proposed by Stüdl *et al.* (2012a, 2012b) have been introduced and explored in this paper. These include modifications that take account of capacity, infrastructure and voltage constraints on the grid and a hierarchical communication topology that facilitates their implementation in an efficient and scalable manner. A price-adjusted available power heuristic is also introduced as a means of encouraging shifting of EV charging load to off-peak times.

Results for a simulation of a representative low-voltage residential distribution network with 50% EV penetration demonstrate that each of the proposed modifications has a positive effect with regard to mitigating the impact of EV charging on the grid with the best results achieved when all the modifications are combined in one algorithm, namely, AIMD-GIVP (price-adjusted AIMD with generation, infrastructure and voltage event response capabilities). In particular, for the scenarios considered in the paper, AIMD-GIVP is able to comfortably support up to 50% EV penetration without adversely affecting customers or requiring strengthening of the distribution network infrastructure. In fact, a significant reduction in the cost of EV charging can be achieved for the customer using AIMD smart

charging relative to uncontrolled charging with the greatest reduction obtained when using TOU price-adjusted available power implementations.

In conclusion, the proposed enhanced AIMD charging strategies provide an effective and scalable solution for residential charging of EVs offering significant benefits to both EV owners and utility companies. More generally, the AIMD framework has the potential to be a flexible platform for implementing demand side management functionality in a fair and equitable way.

## Acknowledgements

The authors would like to thank the Irish Social Science Data Archive (ISSDA) for providing access to the CER Smart Metering Project data. The authors also gratefully acknowledge funding for this research provided by NUI Maynooth (Doctoral Teaching Scholarships Programme) and Science Foundation Ireland (Strategic Research Cluster grant 09/SRC/E1780 and Principal Investigator grant 11/PI/1177).

## Appendix A

TABLE II  
LINE PARAMETERS

<i>Cable (MV)</i>		<i>Service cable (LV)</i>	
<i>Phases</i>	3	<i>Phases</i>	1
Rmatrix( $\Omega$ /km) (Series resistance matrix)	$\begin{bmatrix} 0.2847 & 0.0978 & 0.0947 \\ 0.0978 & 0.2911 & 0.0978 \\ 0.0947 & 0.0978 & 0.2847 \end{bmatrix}$	Positive sequence resistance ( $\Omega$ /km)	0.82
Xmatrix( $\Omega$ /km) (Series reactance matrix)	$\begin{bmatrix} 0.6641 & 0.2778 & 0.2359 \\ 0.2778 & 0.6431 & 0.2778 \\ 0.2358 & 0.2778 & 0.6641 \end{bmatrix}$	Positive sequence reactance ( $\Omega$ /km)	0.30
Cmatrix(nF/km) (Shunt nodal capacitance matrix)	$\begin{bmatrix} 8.9836 & -2.2951 & -1.115 \\ -2.2951 & 9.7049 & -2.328 \\ -1.115 & -2.328 & 8.9836 \end{bmatrix}$	Capacitance ( $\mu$ F) Rated current(A)	0.15 80

## References

- Clement-Nyns, K., Haesen, E. and Driesen, J.** (2010): The impact of charging plug-in hybrid electric vehicles on a residential distribution grid. *IEEE Transactions on Power Systems* 25, 371-380.
- Chen, Y., Oudalov, A. and Wang, J.S.** (2011): Integration of electric vehicle charging system into distribution network. *IEEE 8th International Conference on Power Electronics and ECCE Asia (ICPE & ECCE)*, 593-598.
- CSO** (2009): *National Travel Survey from Central Statistics Office*. Available at: [www.cso.ie/en/media/csoie/releasespublications/documents/transport/2009/nattravel09.pdf](http://www.cso.ie/en/media/csoie/releasespublications/documents/transport/2009/nattravel09.pdf)
- Clement, K., Haesen, E. and Driesen, J.** (2009): Coordinated charging of multiple plug-in hybrid electric vehicles

- in residential distribution grids. *Proceedings of IEEE/PES Power System Conference and Exposition*, 1-7.
- CER** (2009): *Customer supply proposal for smart metering tariff 2010 from Commission for Energy Regulation*.
- CER** (2012): *Electricity customer behaviour trials from Commission for Energy Regulation*.
- EPRI** (2010): *Electric Power Research Institute, OpenDSS manual*. Available at: [sourceforge.net/projects/electricdss/](http://sourceforge.net/projects/electricdss/)
- ESB** (2007): *Distribution code from Electricity Supply Board*. Available at: [www.esb.ie/esbnetworks/en/downloads/Distribution-Code.pdf](http://www.esb.ie/esbnetworks/en/downloads/Distribution-Code.pdf)
- Foley, A., Tyther, B., Calnan, P. and Gallachóir, B.P.Ó.** (2013): Impacts of electric vehicle charging under electricity market operations. *Applied Energy* 101, 93-102.
- Fan, Z.** (2012): A Distributed Demand Response Algorithm and Its Application to PHEV Charging in Smart Grids. *IEEE Transactions on Smart Grid* 3, 1-11.
- Galus, M.D., Waraich, R.A. and Andersson, G.** (2011): Predictive, distributed, hierarchical charging control of PHEVs in the distribution system of a large urban area incorporating a multi agent transportation simulation. *Proceedings of the 17<sup>th</sup> Power Systems Computation Conference (PSCC)*.
- Huang, S. and Infield, D.** (2010): The impact of domestic Plug-in Hybrid Electric Vehicles on power distribution system loads. *International Conference on Power System Technology*, 1-7.
- IEA** (2011): *Technology Roadmap: Electric and plug-in hybrid electric vehicles*, International Energy Agency Available at: [www.iea.org/publications/freepublications/publication/EV\\_PHEV\\_Roadmap.pdf](http://www.iea.org/publications/freepublications/publication/EV_PHEV_Roadmap.pdf)
- Khan, M., Kockelman K.M.** (2012): Predicting the market potential of plug-in electric vehicles using multiday GPS data, *Energy Policy* 46, 225-233.
- Liu, M. and McLoone, S.F.** (2012): Investigation of AIMD based charging strategies for EVs connected to a Low-Voltage Distribution Network. *2<sup>nd</sup> International Conference on Intelligent Computing for Sustainable Energy and Environment (ICSEE)*.
- Lopes, J.A.P., Soares, F.J. and Almeida, P.M.R.** (2011): Integration of electric vehicles in the electric power system. *Proceedings of the IEEE* 99, 168-183.
- Qian, K., Zhou, C., Allan, M. and Yuan, Y.** (2011): Modeling of load demand due to EV battery charging in distribution systems. *IEEE Transactions on Power Systems* 26, 802-810.
- Qian, K., Zhou, C., Allan, M. and Yuan, Y.** (2010): Load model for prediction of electric vehicle charging demand. *International Conference on Power System Technology*, 1-6.
- Richardson, P., Flynn, D. and Keane, A.** (2012a): Local versus centralized charging strategies for electric vehicles in low voltage distribution system. *IEEE Transactions on Smart Grid* 3, 1020-1028.
- Richardson, P., Flynn, D. and Keane, A.** (2012b): Optimal charging of electric vehicles in low-voltage distribution systems. *IEEE Transactions on Power Systems* 27, 268-279.
- Richardson, P., Taylor, J., Flynn, D. and Keane, A.** (2011): Stochastic analysis of the impact of electric vehicles on distribution networks. *Proceedings of CIRED 21<sup>st</sup> International conference on Electricity Distribution*.

- 
- Richardson, P., Flynn, D. and Keane, A.** (2010): Impact assessment of varying penetrations of electric vehicles on low voltage distribution systems. *IEEE Power and Energy Society General Meeting*, 1-6.
- Sortomme, E., Hindi, M.M., MacPherson, S.D.J. and Venkata, S.S.** (2011): Coordinated Charging of Plug-In Hybrid Electric Vehicles to Minimize Distribution System Losses. *IEEE Transactions on Smart Grid* 2, 198-205.
- Shao, S., Pipattanasomporn, M. and Rahman, S.** (2009): Challenges of PHEV penetration to the residential distribution network. *Power & Energy Society General Meeting*, 1-8.
- Stüdl, S., Crisostomi, E., Middleton, R. and Shorten, R.** (2012a): AIMD-like algorithms for charging electric and plug-in hybrid vehicles. *Proceedings of IEEE International Electric Vehicle Conference (IEVC)*, 1-8.
- Stüdl, S., Crisostomi, E., Middleton, R. and Shorten, R.** (2012b): A flexible distributed framework for realising electric and plug-in-hybrid vehicle charging policies. *International Journal of Control* 85, 1130-1145.
- Shorten, R., Wirth, F. and Leith, D.** (2006): A positive systems model of TCP-like congestion control: asymptotic results. *IEEE/ACM Transactions on Networking* 14, 616-629.
- SEAI** (2012): *Time-varying electricity price from Sustainable Energy Authority of Ireland*. Available at: [www.seai.ie/Renewables/Smart\\_Grids/The\\_Smart\\_Grid\\_for\\_the\\_Consumer/Home\\_Consumer/Smart\\_Meter/Time\\_varying\\_electricity\\_price/](http://www.seai.ie/Renewables/Smart_Grids/The_Smart_Grid_for_the_Consumer/Home_Consumer/Smart_Meter/Time_varying_electricity_price/)
- SEAI** (2007): *Hybrid Electric and Battery Electric Vehicles: Technology, Costs and Benefits*. Available at: [www.seai.ie/News\\_Events/Press\\_Releases/Costs\\_and\\_benefits.pdf](http://www.seai.ie/News_Events/Press_Releases/Costs_and_benefits.pdf)