



## Bibani, Rashid Hamid (2013) Exploring the neuroprotective and alerting effects of modafinil in multiple sclerosis and experimental autoimmune encephalomyelitis. PhD thesis, University of Nottingham.

### Access from the University of Nottingham repository:

[http://eprints.nottingham.ac.uk/13343/1/E\\_Thesis-Bibani.pdf](http://eprints.nottingham.ac.uk/13343/1/E_Thesis-Bibani.pdf)

### Copyright and reuse:

The Nottingham ePrints service makes this work by researchers of the University of Nottingham available open access under the following conditions.

- Copyright and all moral rights to the version of the paper presented here belong to the individual author(s) and/or other copyright owners.
- To the extent reasonable and practicable the material made available in Nottingham ePrints has been checked for eligibility before being made available.
- Copies of full items can be used for personal research or study, educational, or not-for-profit purposes without prior permission or charge provided that the authors, title and full bibliographic details are credited, a hyperlink and/or URL is given for the original metadata page and the content is not changed in any way.
- Quotations or similar reproductions must be sufficiently acknowledged.

Please see our full end user licence at:

[http://eprints.nottingham.ac.uk/end\\_user\\_agreement.pdf](http://eprints.nottingham.ac.uk/end_user_agreement.pdf)

### A note on versions:

The version presented here may differ from the published version or from the version of record. If you wish to cite this item you are advised to consult the publisher's version. Please see the repository url above for details on accessing the published version and note that access may require a subscription.

For more information, please contact [eprints@nottingham.ac.uk](mailto:eprints@nottingham.ac.uk)



The University of  
**Nottingham**

UNITED KINGDOM • CHINA • MALAYSIA

School of Clinical Sciences

**EXPLORING THE NEUROPROTECTIVE AND  
ALERTING EFFECTS OF MODAFINIL IN  
MULTIPLE SCLEROSIS AND EXPERIMENTAL  
AUTOIMMUNE ENCEPHALOMYELITIS**

**Rashid Hamid Bibani**

M.B.CH.B., M.I.M.

Thesis submitted to the University of Nottingham for the degree of Doctor of  
Philosophy in Clinical Neurology

MAY 2013

**"In the name of ALLAH, the Entirely Merciful, the  
Especially Merciful"**

﴿ به ناوی خوای به خشندهی میهره بان ﴾

**DEDICATION**

*I dedicate this thesis to my wonderful family. Particularly to my understanding and patient wife, Qhadamkhir, who has put up with these many years of research. This was all possible thanks to her continuous encouragement and her moral support. To my precious Children: Rasti, Rawsht, and Asuda who are the joy of our lives. Finally, I dedicate this work to those who believe in diligence, science, art, and the pursuit of academic excellence.*

## **DECLARATION OF ORIGINALITY**

I hereby declare that this thesis is my own work based on research that was undertaken during my study in the Clinical Neurology Division, School of Clinical Sciences, the University of Nottingham and Queens Medical Centre. to the best of my knowledge it contains no material previously published or written by another person, or no material which to a substantial extent has been accepted for the award of any other degree except where due acknowledgement is made in the thesis. Any contribution made to the research by others, with whom I have worked at the university of Nottingham or elsewhere, is explicitly acknowledged in the thesis.

## TABLE OF CONTENTS

	<b>Page</b>
<b>DEDICATION.....</b>	<b>II</b>
<b>DECLARATION OF ORIGINALITY.....</b>	<b>III</b>
<b>TABLE OF CONTENTS.....</b>	<b>IV</b>
<b>LIST OF PUBLICATIONS AND CONFERENCE PRESENTATIONS DERIVED FROM THE WORK.....</b>	<b>XI</b>
<b>ABSTRACT.....</b>	<b>XII</b>
<b>ACKNOWLEDGMENTS.....</b>	<b>XV</b>
<b>LIST OF ABBREVIATION.....</b>	<b>XVII</b>
<b>LIST OF FIGURES.....</b>	<b>XXI</b>
<b>LIST OF TABLES.....</b>	<b>XXIII</b>
<b>CHAPTER 1 INTRODUCTION.....</b>	<b>1</b>
Overview of the chapter.....	2
1.1 MULTIPLE SCLEROSIS.....	3
1.1.1 History and background of Multiple Sclerosis.....	3
1.1.2 Epidemiology of Multiple Sclerosis.....	6
1.1.3 Pathogenesis of Multiple Sclerosis.....	7
1.1.3.1 Plaque formation.....	7
1.1.3.2 Neurodegeneration in Multiple Sclerosis.....	9
1.1.3.2.1 Axonal Degeneration.....	11
1.1.3.2.1.1 Mechanism of axonal degeneration.....	11
1.1.3.2.1.1.1 Axonal degeneration in acute inflammatory process.....	11
1.1.3.2.1.1.2 Progressive axonal damage in chronic plaques.....	12
1.1.3.3 Gray matter lesions in Multiple Sclerosis.....	13
1.1.4 Clinical Courses of Multiple Sclerosis.....	13
1.1.5 Clinical Features of Multiple Sclerosis.....	14
1.1.6 Disabilities in Multiple Sclerosis.....	16
1.1.6.1 Physical Disabilities.....	16
1.1.6.2 Cognitive Disabilities.....	17
1.1.7 Fatigue in Multiple Sclerosis.....	17
1.1.7.1 Definition and overview.....	17
1.1.7.2 Types of Fatigue.....	19
1.1.7.2.1 Motor Fatigue.....	19
1.1.7.2.2 Cognitive Fatigue.....	20
1.1.7.3 Measurement of Fatigue.....	20
1.1.7.4 Pathogenesis of Fatigue.....	20

1.1.7.5	Management of Fatigue.....	22
1.1.7.5.1	Non-Pharmacological therapies.....	23
1.1.7.5.2	Pharmacological drug therapies.....	23
1.1.8	Autonomic dysfunction in Multiple Sclerosis.....	24
1.1.9	Diagnosis of Multiple Sclerosis.....	25
1.1.9.1	Diagnostic criteria for Multiple Sclerosis.....	25
1.1.9.1.1	Poser Criteria.....	25
1.1.9.1.2	The MacDonald Criteria.....	26
1.1.9.1.2.1	Revised 2005.....	26
1.1.9.1.2.2	Revised 2010.....	27
1.1.10	Treatment of Multiple Sclerosis.....	27
1.1.10.1	Acute Treatments.....	27
1.1.10.2	Disease Modifying Therapies.....	28
1.1.10.3	Combination Therapies.....	32
1.1.10.4	Investigational Therapies.....	33
1.1.10.5	Symptomatic Therapies.....	37
1.1.10.6	Neuroprotective Agents.....	39
1.1.11	Prognosis and Complications of Multiple Sclerosis.....	43
1.2	EXPERMINAT AUTOIMMUNE ENCEPHALOMYELITIS (EAE).....	45
1.2.1	EAE Induction.....	45
1.2.2	Pathogenesis of EAE.....	45
1.2.3	Clinical scores of EAE.....	46
1.2.4	EAE and Multiple Sclerosis.....	46
1.2.4.1	EAE and multiple sclerosis treatments.....	47
1.2.4.2	Major differences between EAE and multiple sclerosis.....	47
1.3	MODAFINIL (PROVIGIL).....	48
1.3.1	Introduction.....	48
1.3.2	Pharmacodynamic properties of Modafinil.....	49
1.3.3	Clinical efficacy and Tolerability of Modafinil.....	50
1.3.4	Mechanism of Action of Modafinil.....	52
1.3.4.1	Effects of Modafinil on the Dopaminergic Pathways.....	52
1.3.4.2	Effects of Modafinil on Noradrenergic Pathways.....	53
1.3.4.3	Effects of Modafinil on Glutamate.....	54
1.3.4.4	Effect of Modafinil on gama amino butyric acid (GABA).....	54
1.3.4.5	Effect of Modafinil on serotonin.....	54
1.3.4.6	Effects of Modafinil on Histaminergic Pathways.....	55
1.3.4.7	Effects of Modafinil on Orexinergic Pathways.....	55

1.3.5	Approved Indications of Modafinil.....	55
1.3.5.1	Narcolepsy.....	55
1.3.5.2	Obstructive Sleep Apnoea (OSA).....	56
1.3.5.3	Shift-Work Sleep Disorder (SWSD).....	56
1.3.6	Investigational Uses of Modafinil.....	57
1.3.6.1	Neurological Disorders.....	57
1.3.6.1.1	Parkinson's disease.....	57
1.3.6.1.2	Myotonic Dystrophy.....	57
1.3.6.2	Psychiatric Disorders.....	58
1.3.6.2.1	Attention Deficit Hyperactivity Disorder (ADHD).....	58
1.3.6.2.2	Depression.....	58
1.3.6.2.3	Schizophrenia.....	58
1.3.6.2.4	Alzheimer's Disease.....	59
1.3.6.2.5	Effect of modafinil on addiction and substances dependency.....	59
1.3.6.2.5.1	Cocaine.....	59
1.3.6.2.5.2	Amphetamines.....	60
1.3.6.2.5.3	Nicotine.....	60
1.3.6.3	Effect of modafinil on Disorders Associated with Fatigue.....	60
1.3.6.3.1	Chronic Fatigue Syndrome.....	60
1.3.6.3.2	Fatigue in Post-Polio Syndrome.....	60
1.3.6.3.3	Fatigue in Multiple Sclerosis.....	61
1.3.6.3.4	Fatigue in Parkinson's disease.....	61
1.3.6.3.5	Cancer-related Fatigue.....	62
1.3.6.4	Recovery from General Anaesthesia.....	62
1.3.6.5	Sleep-Deprived Emergency Room Physicians.....	62
1.3.6.6	Effects of modafinil on quality of life (QoL).....	62
1.3.6.7	Effects of modafinil on Cognitive Performance.....	63
1.3.6.8	Effects of Modafinil in Healthy Volunteers.....	63
1.3.6.8.1	Non-sleep deprived volunteers.....	63
1.3.6.8.2	Sleep-deprived volunteers.....	63
1.3.7	Neuroprotective aspects of modafinil.....	64
1.4	SUMMARY AND CONCLUSIONS.....	67

<b>CHAPTER 2 EXPLORING THE POTENTIAL NEUROPROTECTIVE EFFECTS OF MODAFINIL IN MULTIPLE SCLEROSIS (RETROSPECTIVE STUDY).....</b>	<b>68</b>
2.1 Introduction.....	69

2.2	Methods.....	69
2.2.1	Patients.....	69
2.2.2	Data Analysis and Statistics.....	70
2.3	Results.....	71
2.3.1	Demographic and Clinical Characteristics.....	71
2.3.1.1	Patient demographics.....	71
2.3.2	Effect of modafinil on EDSS progression.....	71
2.3.3	Evaluation the role of DMTs concomitantly received with modafinil on EDSS changes.....	74
2.4	Discussion.....	76
2.4.1	Limitations of the study.....	77
2.4.2	Conclusions.....	79
2.4.3	Future work.....	79

**CHAPTER 3 MODULATION OF EXPERIMENTAL AUTOIMMUNE ENCEPHALOMYELITIS (EAE) BY MODAFINIL.....80**

3.1	Introduction.....	81
3.2	Methods and Animals.....	83
3.2.1	Animals.....	83
3.2.2	Peptide.....	83
3.2.3	Induction of EAE.....	83
3.2.4	Treatment of mice.....	84
3.2.5	Clinical evaluation.....	85
3.2.6	Immunohistopathological evaluation of neuroprotection potential of modafinil in EAE .....	85
3.2.6.1	Histopathological Examination of EAE.....	86
3.2.6.2	Determination of Various Cytokines/Chemokines in Serum.....	87
3.2.6.3	Detection of modafinil-Induced Apoptosis in Primary T Cells.....	87
3.2.6.4	Statistical analysis of immunohistopathological data.....	88
3.2.7	Statistical Analysis.....	88
3.3	Results.....	88
3.3.1	Modafinil ameliorated clinical severity of EAE mice.....	88
3.4	Discussion.....	91

**CHAPTER 4 ASSOCIATION OF A DEFICIT OF AROUSAL WITH FATIGUE IN MULTIPLE SCLEROSIS: EFFECT OF MODAFINIL.....94**



4.1	Introduction.....	95
4.2	Material and Methods.....	99
4.2.1	Subjects.....	99
4.2.1.1	Patients.....	100
4.2.1.2	Healthy controls.....	101
4.2.2	Drugs.....	101
4.2.3	Design.....	101
4.2.4	Procedure.....	102
4.2.5	Tests and apparatus.....	102
4.2.5.1	Tests of alertness.....	102
4.2.5.1.1	Self-rating of alertness.....	102
4.2.5.1.2	Instrumental measurements of alertness.....	103
4.2.5.1.2.1	Critical flicker fusion frequency (CFFF).....	103
4.2.5.1.2.2	Pupillographic sleepiness test (PST).....	103
4.2.5.1.3	Psychomotor tests.....	104
4.2.5.1.3.1	Choice reaction time (CRT).....	104
4.2.5.2	Tests of autonomic function.....	104
4.2.5.2.1	Cardiovascular measures.....	104
4.2.5.2.2	Pupil diameter.....	105
4.2.6	Data analysis and statistics.....	105
4.3	Results.....	105
4.3.1	Measures of alertness.....	105
4.3.1.1	Comparison of groups prior to treatment.....	105
4.3.1.2	Effect of modafinil.....	107
4.3.2	Autonomic measures.....	108
4.3.2.1	Comparison of groups prior to treatment.....	108
4.3.2.2	Effect of modafinil.....	108
4.3.2.2.1	Cardiovascular measures.....	108
4.3.2.2.2	Pupil diameter.....	110
4.3.3	Subjects' verbal reports.....	111
4.4	Discussion.....	111

**CHAPTER 5 CEREBROSPINAL FLUID OLIGOCLONAL BAND AND  
MULTIPLE SCLEROSIS PROGRESSION: A RETROSPECTIVE STUDY.....118**

5.1	Introduction.....	119
5.2	Methods.....	122
5.2.1	Subjects and Setting.....	122

5.2.2	Data used and main outcome measures.....	122
5.2.3	Study design.....	123
5.2.4	Statistical analyses.....	123
5.3	Results.....	123
5.3.1	Association between OCB status and disease progression.....	124
5.3.2	OCB results over time.....	125
5.3.3	Effects of OCB status on time to diagnosis and disease initial type.....	126
5.4	Discussion.....	126
5.5	Conclusion.....	128
<b>CHAPTER 6 A META-ANALYSIS OF fMRI STUDIES ON FATIGUE IN</b>		
<b>MULTIPLE SCLEROSIS..... 130</b>		
6.1	Introduction.....	131
6.1.1	Structural MRI and Fatigue in Multiple Sclerosis.....	131
6.1.1	fMRI and fatigue in Multiple Sclerosis.....	132
6.2	Methods.....	134
6.2.1	Local activation likelihood estimate (LocalALE).....	134
6.2.2	Study inclusion.....	135
6.2.3	Data extraction.....	136
6.3	Results.....	137
6.3.1	Multiple sclerosis patients with fatigue.....	137
6.3.2	Multiple sclerosis patients without reported subjective fatigue.....	138
6.3.3	Multiple sclerosis patients with fatigue vs. MS patients without fatigue....	139
6.3.4	Healthy controls under same tasks as MS patients with fatigue.....	140
6.3.5	Brain activations in multiple sclerosis patients (with or without fatigue) vs. healthy controls.....	141
6.3.6	Comparing ALE in Multiple sclerosis patients and healthy controls.....	142
6.3.7	Activation clusters related to modafinil exposure in people without conventional MRI-detectable brain morphological lesions (healthy; drug addicts; narcoleptic patients).....	142
6.3.8	Activation or deactivation clusters in people with chronic fatigue syndrome vs. healthy controls.....	144
6.4	Discussion.....	145
6.4.1	Brain activation in MS with fatigue, without fatigue or undergoing fatiguing tasks vs. healthy controls.....	147
6.4.2	MS patients with fatigue: role of thalamo-striate loop.....	148
6.4.3	Modafinil-related activations and deactivations: possible implications for fatigue in Multiple Sclerosis.....	150
6.4.4	Conclusions.....	152

<b>CHAPTER 7 GENERAL SUMMARY AND CONCLUSIONS</b> .....	<b>153</b>
7.1 General summary.....	154
7.2 Conclusions.....	158
7.3 Limitations and Strengths of the studies.....	160
7.3.1 Limitations of the studies.....	160
7.3.2 Strengths of the studies.....	161
7.4 Clinical implementation and importance of the findings.....	161
7.5 Difficulties in clinical implication OF modafinil.....	162
7.6 Recommendations for future research.....	163
 <b>BIBIOGRAPHY</b> .....	 <b>164</b>
 <b>APPENDICES</b> .....	 <b>206</b>
Appendix 1 Ethics approval.....	207
Appendix 2 Expanded disability status scale (EDSS).....	207
Appendix 3 McDonald criteria for diagnosis of multiple sclerosis (2001).....	208
Appendix 4 The 2005 revisions to the McDonald diagnostic criteria for multiple sclerosis.....	208
Appendix 5 Magnetic resonance imaging criteria to demonstrate dissemination of lesions in time.....	210
Appendix 6 Magnetic resonance imaging criteria to demonstrate brain abnormality and demonstration of dissemination in space.....	210
Appendix 7 Diagnosis of multiple sclerosis in disease with progression from onset.....	211
Appendix 8 Revised McDonald diagnostic criteria (2010).....	212
Appendix 9 Brodmann areas in the brain of human beings.....	213
Appendix 10 Protocol of a randomised, assessor-blind, non-treatment controlled, parallel group design exploratory trial to explore the neuroprotective potential of modafinil in multiple sclerosis.....	215

## **LISTS OF PUBLICATIONS CONFERENCE PRESENTATIONS DERIVED FROM THE WORK**

### **Publications**

**Bibani, R. H.**, Tench, C. R., George, J., Manouchehrinia, A., Palace, J., Constantinescu, C. S., 2012. Reduced EDSS progression in multiple sclerosis patients treated with modafinil for three years or more compared to matched untreated subjects. *Multiple Sclerosis and Related Disorders* 1, 131-135.

Niepel, G., **Bibani, R. H.**, Vilisaar, J., Langley, R. W., Bradshaw, C. M., Szabadi, E., Constantinescu, C. S., 2012. Association of a deficit of arousal with fatigue in multiple sclerosis: Effect of modafinil. *Neuropharmacology* 64, 380-388.

### **Conference Presentations:**

**R.H. Bibani.** C.R. Tench, C.S. Constantinescu, 2011. Positive effect of modafinil on EDSS progression in multiple sclerosis. 21th Meeting of the European Neurological Society, Lisbon, Portugal / 28 - 31 May 2011.

**Rashid H Bibani**, Christopher R Tench and Cris S Constantinescu, A drug used to treat fatigue in Multiple Sclerosis may help cure the disease completely. Research Showcase, the University of Nottingham 7<sup>th</sup> June 2011.

**Rashid H Bibani**, Christopher R Tench and Cris S Constantinescu, Modafinil and EDSS progression in multiple sclerosis. The Former Institute of Neuroscience, the University of Nottingham, Medical School Foyer 28<sup>th</sup> September 2011.

## **ABSTRACT**

Multiple sclerosis (MS) is the most common demyelinating disease. It is characterised by a great variety of neurological deficits, which most commonly present initially in a relapsing remitting fashion and then take on a gradually progressive course. MS is incurable, since present medications do not counteract progression of the disease. Therefore, an additional strategy aims to focus on prevention of the neuronal loss in an attempt to stop or slow down the progression of the disease.

In this thesis the neuroprotective potential of modafinil is tested in MS in a retrospective study. The ability of modafinil to reduce neurological dysfunction in the MS animal model is also investigated.

In retrospective study the expanded disability status scale (EDSS) progression of thirty patients with MS who received modafinil for the treatment of MS-related fatigue for an uninterrupted period of 3 years or more was compared with ninety matched patients not treated with modafinil, followed up for a matching period of time. We found that the EDSS increase in patients not treated with modafinil was greater than in those treated with modafinil in both relapsing/remitting and progressive MS.

In another experiment, we evaluated the effect of two treatment doses (low dose and high dose) of modafinil on the level of disability in experimental autoimmune encephalomyelitis (EAE) in a placebo controlled study. Modafinil decreased the severity of EAE at both treatment doses and the effect was greater in high dose.

The study in chapter 4 was aimed to explore the anti-fatigue and alerting effects of modafinil in MS in an attempt to link these with the potential neuroprotective effects of modafinil. This was a detailed reanalysis of a prospective placebo controlled study (based on prospectively collected data), in which we examined whether there

is any difference between MS patients with fatigue, MS patients without fatigue, and healthy controls on measures of alertness and autonomic function. We found that MS patients with fatigue, compared with healthy controls, had reduced level of alertness on all the tests used, MS patients with fatigue had a reduced level of autonomic function compared to the other two groups. Furthermore, we found that Modafinil displayed alerting and sympathomimetic effects in all three groups of subjects.

In Chapter 5, we assessed a problem relevant to the progression of MS. We take advantage of the methods and data used in the chapter 2 to apply the same retrospective study methodology and statistical retrospective modeling of EDSS progression using the linear regression model to look at the role of oligoclonal band (OCB) positivity or negativity in EDSS progression. Unlike previous studies in smaller cohorts, we did not find that OCB negative patients have a more benign course of disease.

The meta-analysis study in chapter 6 was designed to generate some knowledge regarding the central mechanism of fatigue in general and fatigue related to MS, using a novel functional magnetic resonance imaging (fMRI) meta-analysis method developed by CR Tench in our group. The study has also aimed to explore the brain areas which could be activated by modafinil treatment. The conclusion of this study was that the thalamus and striate are central and relevant nodes for the pathogenesis of fatigue in MS. The study has not detected the specific brain area to be activated by modafinil and showed multiple brain activations.

With regard to the promising findings in our previous experiments, the protocol of a prospective phase II clinical trial was designed and detailed in appendix 10 using radiological primary and clinical secondary outcome measures.

In conclusion, modafinil may slow down the progression of disability in patients with MS and decrease disease severity in EAE. Modafinil can display alerting and

sympathomimetic effects in MS patients as well as in healthy subjects. The thalamus and striate are central and relevant nodes for the pathogenesis of fatigue in MS. These are also areas affected by the MS gray matter pathology and may be targets for neuroprotection by modafinil in MS. Finally, we have not reported a significant difference in disease progression measured by EDSS and MSSS between OCB negative and OCB positive in our patients with MS.

This seemingly heterogeneous group of experiments, primarily centred on modafinil's potential as mechanistic therapy in MS, bring, I hope, new knowledge of aspects of disease progression and pharmacological neuroprotection in a stage of the disease where therapeutic options are currently limited and the need for new treatments is great.

## ACKNOWLEDGMENTS

First of all, praise is due to almighty **ALLAH** with His compassion and mercifulness to allow me finalizing this Ph.D. project.

I am in deep gratitude to the **Iraqi Ministry of Higher Education and Scientific Research**, and to my employers, **Hawler Medical University in Kurdistan**, for such a wonderful opportunity to travel to distant lands, in comfort and security. It is my duty to repay with my service for many years to come.

I am extremely grateful to the **University of Nottingham** for all of the education and experiences I have gained over the past four years. This has been an intense time of personal development and learning to deal with some of life's trials and tribulations.

My sincerest and everlasting thanks to my supervisor, **Professor Cris Constantinescu**, for his ever cheerful guidance through these years and for doing the hard pioneering work, paving the way for my little research. His insightful comments have helped sharpen my scientific writing, and I am grateful for his advice in conducting and publishing research.

Thanks to my co-supervisor **Dr Christopher Tench** for his guidance through the intricacies of research is much appreciated, especially during the statistical analysis of the data he provided me with statistical advice and helped me with statistical calculations and interpretation of results.

There have been some other people who have helped me over the last four years and some of them contributed one way or another to this work I would particularly, like to thank;

**Dr Graham Niepel** who produced the initial database for the body of work contained within the chapter four in this thesis, as well as **Professor Szabadi** who had an excellent support in statistical analysis and interpretation of the results as well as the



invaluable advice in the planning and execution of this study. I would like to stress that this study would not have been possible to be published without his contribute.

**Dr Bruno Gran and James Crooks** for their immense technical support regarding induction of EAE and monitoring the clinical scores of the mice and invaluable advice through most part of this experiment.

**Dr Radu Tananescu** for his enormous contribution who shared me a lot of knowledge and opinions during conducting the meta-analysis study.

**Ali Manuocherinia** for letting me to have access into his pooled database which I used in part, in the study described in chapter five as well as his help in the statistical analysis of the data.

My deepest gratitude to **my family** without whom none of this would be possible: To my wife **Qhadamkhir**, for her essential support, especially at times when I could do nothing else other than this work, my three children: **Rasti**, **Rawsht** and **Asuda** for their love, and my family back home for their understanding and patience, especially my mum, **Rahma**, for her love, care and support.

Finally, thanks to colleagues and staffs in the Division of Clinical Neurology for the camaraderie without which office life would probably be unbearable.

## LIST OF ABBERRIATION

AD	autonomic dysfunction
ABM	autologous bone marrow
ACTH	adrenocorticotrophic hormone
ADHD	attention deficit-hyperactivity disorder
ALE	activation likelihood method
AMPA	2-amino-3-(3-hydroxy-5-methyl-soxazol-4-yl) propanoic acid
ANS	autonomic nervous system
APC	antigen-presenting cells
ATP	adenosine triphosphate
BA	brodmann area
BBB	blood brain barrier
BDI	Beck Depression Inventory
BOLD	blood oxygen level-dependent
BP	blood pressure
CBT	cognitive behaviour therapy
CC	corpus callosum
CD	cluster of differentiation
CDMS	clinically definite multiple sclerosis
CFA	complete Freund's adjuvant
CFFF	critical flicker fusion frequency
CFS	chronic fatigue syndrome
CHMP	Committee for Medicinal Products for Human Use
CIS	clinically isolated syndrome
CNS	central nervous system
CNTF	cilliary neurotrophic factor
CPAP	continuous positive airway pressure
CRT	choice reaction time
CSF	cerebro spinal fluid
DA	dopamine
DAT	dopamine transporters
DMSO	dimethylsulfoxide
DMTs	disease modifying therapies
DPCC	dorsal posterior cingulate cortex
DR	dopamine receptor
EAE	experimental autoimmune encephalomyelitis

EDS	excessive daytime sleepiness
EDSS	expanded disability status scale
ESS	Epworth sleepiness scale
FAI	fatigue assessment instrument
FCDR	false cluster discovery rate
FDA	food and drug administration
FDS	fatigue descriptive scale
FWER	family wise error rate
FIS	fatigue impact scale
FMRI	functional magnetic resonance imaging
FODOS	fields of dead oligodendrocytes
FOSQ	functional outcomes of sleep questionnaire
FSS	fatigue severity scale
GA	glatiramer acetate
GABA	gamma-amino butyric acid
GM	gray matter
GNDS	Guy's Neurological Disability Scale
HLA	human leukocyte antigen
IEF	isoelectric focusing
IGF	insulin like growth factor
IgG	immunoglobulin G
IL	interleukin
IM	intramuscular
INF	interferon
IV	intravenous
LH/PF	lateral hypothalamic/prefrontal
LIF	leukaemia-inhibitory factor
LP	lumbar puncture
MBP	myelin basic protein
MFG	medial frontal gyrus
MFIS	modified fatigue impact scale
MHC	major histocompatibility complex
MHRA	Medicines and Healthcare Products Regulatory Agency
MNI	Montreal Neurological Institute
MOG	myelin oligodendrocyte glycoprotein
MPTP	1-methyl-4-phenyl-1,2,3,6-tetrahydropyridine
MRI	magnetic resonance imaging

MRS	magnetic resonance spectroscopy
MRT	motor reaction time
MS	multiple sclerosis
MSC	mesenchymal stem cell
MSFC	multiple sclerosis functional composite
MSLT	multiple sleep latency test
MSSS	multiple sclerosis severity scale
MWT	maintenance of wakefulness test
NAA	N-acetylaspartate
NAA/Cr	N-acetylaspartate/creatinine
NAT	noradrenalin transporters
NE	norepinephrine
NET	norepinephrine transporters
NFI-MS	neurological fatigue index
NMO	neuromyelitis optica
NO	nitric oxide
OCB	oligo clonal band
OSA	obstructive sleep apnoea
PASAT	paced auditory serial addition test
PBS	phosphate-buffered saline
PD	Parkinson's disease
PET	positron emission tomography
PLP	proteolipid protein
PPAR	peroxisome proliferators-activated receptor
PPMS	primary progressive multiple sclerosis
PRMS	relapsing remitting multiple sclerosis
PST	pupillographic sleepiness test
PUI	papillary unrest index
QoL	quality of life
ROI	region of interest
RRMS	relapsing remitting multiple sclerosis
RRT	recognition reaction time
SDT	symbol digit substitution test
SPMS	secondary progressive multiple sclerosis
SRI	serotonin receptor inhibitors
SSR	sympathetic skin response
SSS	Stanford Sleepiness Scale

SWSD	shift works sleep disorder
TCR	T-cell receptor
TGF	tumor growth facto
TH	T helper
TMN	tuberomamillary nucleus
TNF	tumour necrosis factor
TRT	Total Reaction Time
VAS-F	visual analogue scales for fatigue
VFQ25	visual function questionnaire
VLA-4	very late antigen
VLPO	ventrolateral preoptic nucleus
WM	white matter

## LIST OF FIGURES

<b>Figure 1.1</b> Dr Martin Charcot (1825-1893).....	4
<b>Figure 1.2</b> Geography of multiple sclerosis and migration.....	7
<b>Figure 1.3</b> Characteristics brain pathology in multiple sclerosis.....	8
<b>Figure 1.4</b> Immune-mediated demyelination and axonal transaction.....	10
<b>Figure 1.5</b> Clinical courses of multiple sclerosis.....	14
<b>Figure 1.6</b> Chemical structure of modafinil.....	50
<b>Figure 2.1</b> Mean $\pm$ SEM EDSS changes at baseline EDSS and EDSS after 3 or more years treatment or follow-up in Modafinil-treated group and non-modafinil group with progressive and RRMS.....	73
<b>Figure 2.2</b> Mean $\pm$ SEM EDSS changes at baseline EDSS and EDSS after 3 or more years treatment in modafinil-treated group concomitantly received or not received DMTs.....	75
<b>Figure 3.1</b> Effect of modafinil treatment on clinical score of EAE associated disease activity.....	89
<b>Figure 3.2</b> The maximum Severity of clinical course in three groups of EAE.....	90
<b>Figure 4.1</b> Measures of alertness: comparison of groups prior to treatment.....	106
<b>Figure 4.2</b> Measures of alertness: effect of modafinil.....	107
<b>Figure 4.3</b> Autonomic measures: comparison of group prior to treatment.....	109
<b>Figure 4.4</b> Relationship between light intensity and Pupil diameter.....	110
<b>Figure 4.5</b> Schematic diagram of the dopaminergic arousal system showing	

the possible sites of action of modafinil.....	116
<b>Figure 6.1</b> ALE maps for the independent activation likelihood analysis in MS patients with fatigue undergoing motor tasks-significant clusters.ALE maps for the independent activation likelihood analysis in MS patients with fatigue undergoing motor tasks - significant clusters.....	137
<b>Figure 6.2</b> ALE maps for the independent activation likelihood analysis in MS patients without fatigue undergoing motor tasks-significant clusters (FCDR level 0.06).....	139
<b>Figure 6.3</b> ALE maps for the independent activation likelihood analysis in MS patients with fatigue vs. without fatigue undergoing motor tasks-significant clusters (FCDR level 0.07).....	140
<b>Figure 6.4</b> ALE maps for independent activation likelihood analysis in MS patients with fatigue vs. without fatigue undergoing motor tasks-significant clusters.....	142
<b>Figure 6.5</b> ALE maps for the independent activation likelihood analysis in subjects under modafinil (healthy; drug addicts; narcoleptic patients) all clusters.....	144
<b>Figure 6.6</b> ALE for the independent activation likelihood in subjects under modafinil (healthy; drug addicts; narcoleptic patients) -significant clusters of activations.....	144

## LIST OF TABLES

<b>Table 1.1</b> Clinical features of multiple sclerosis.....	5
<b>Table 1.3</b> Symptomatic treatments for multiple sclerosis.....	37
<b>Table 2.1</b> Demographic characteristics and clinical epidemiology of the patients.....	71
<b>Table 2.2</b> Patient's Characteristics according to the multiple sclerosis clinical types.....	72
<b>Table 2.3</b> Fisher's exact test analysis in the modafinil-treated and untreated groups have baseline EDSS 0-5 with EDSS increase by $\geq 1.0$ point and the patients have baseline EDSS $\geq 5.5$ score with EDSS increase by $\geq 0.5$ point.....	74
<b>Table 2.4</b> Mean $\pm$ SD of the EDSS1 (baseline) and EDSS2 (post treatment) in modafinil-treated patients received or not received DMTs.....	75
<b>Table 3.1</b> Mean $\pm$ SEM of the subject groups.....	89
<b>Table 4.1</b> Characteristics of the subjects.....	100
<b>Table 5.1</b> Demographic and clinical characteristics of the patients.....	124
<b>Table 5.2</b> Results of linear regression models analysis to calculate the effects of OCB on EDSS and MSSS.....	125
<b>Table 5.3</b> Prevalence of the OCB positive and OCB negative patients at the time of the diagnosis.....	125
<b>Table 6.1</b> Studies providing data on activations in MS patients with fatigue.....	137
<b>Table 6.2</b> Studies providing data on activations in MS patients without fatigue.....	138
<b>Table 6.3</b> Studies providing data on activations in MS patients with fatigue vs. patients without fatigue.....	139



<b>Table 6.4</b> Studies providing data on activation in healthy control.....	140
<b>Table 6.5</b> Studies providing data on activations in MS patients (with fatigue/without fatigue) vs. healthy controls.....	141
<b>Figure 6.6</b> Studies providing data on activations in subjects under modafinil (healthy; drug addicts; narcoleptic patients).....	143
<b>Table 6.7</b> Studies providing data on activations or deactivations clusters in people with CFS vs. healthy controls.....	145

## **CHAPTER 1 INTRODUCTION**

## **Overview of the chapter**

This chapter begins with a general review of multiple sclerosis (MS), regarding its history and background, epidemiology, immunopathology, clinical courses, clinical features, diagnosis, current therapies for MS and the future treatment strategies. As experimental autoimmune encephalomyelitis (EAE) is a useful model for predicting success with clinical trials in MS, and it is considered a valuable model for aiding the development of new treatments for MS, a section of this chapter is an overview of EAE, focusing on: history, EAE induction, pathophysiology and its contribution to the development, validation, and testing of MS drugs. This is followed by a review of modafinil, the wakefulness-promoting drug, which focuses on general description of the drug, mode of the action, the effect of modafinil in MS and other neurodegenerative diseases, and the possible neuroprotective properties of modafinil.

## **1.1 MULTIPLE SCLEROSIS**

MS is the most common demyelinating disease. It is characterised clinically by a great variety of neurological deficits, which most commonly present initially in a relapsing remitting fashion and then take on a gradually progressive course. Pathologically, MS is characterised by inflammation, demyelination, axonal loss, and gliosis.

### **1.1.1 History and background of Multiple Sclerosis**

In the United Kingdom the case of Elizabeth Foster, dating to 1757, likely, represents the first reasonably convincing case of MS in the medical literature. She was presented with paralytic disorders in the left side of the body. She was treated by electrical stimulations. This case was reported by Dr Patrick Brydone, and the report was published in the leading scientific journal of the day (*Philosophical Transactions*) (Lincoln and Ebers, 2012).

Two cases have been reported from the late 13<sup>th</sup> century, a woman in Iceland (Poser, 1994), and a Dutch woman (Medaer, 1979) both with chronic, multifocal, and partially remitting neurologic illnesses that might have been MS.

In 1868 MS was pathologically described by Jean-Martin Charcot (Figure 1.1) a French neurologist at the University of Paris, who examined a young woman with a tremor and some other neurological features including slurred speech and abnormal eye movements, which were different from neurological features in other reported neurological conditions. Post-mortem, he examined her brain and found the characteristic plaques of MS (Murray, 2009). In the USA MS was recognized by Dr. Edward Seguin in 1878. In 1916 Dr James Dawson at the University of Edinburgh performed microscopic examinations of the MS patient's brain post-mortem.



**Figure 1.1 Dr Martin Charcot (1825-1893).** Source: (Paciaroni et al., 2008).

MS is a chronic progressive inflammatory and degenerative disease of the central nervous system (CNS). It is characterised by the presence of areas of multifocal demyelination (plaques) that result from damage the protective coat (myelin) of nerve fibres. Also there is destruction of oligodendroglia, perivascular inflammation, and chemical changes in lipid and protein constituents of myelin in and around the plaques.

In the mid-1990s the understanding of MS changed. The results of clinical trials and findings from neuropathology of MS demonstrated a neurodegenerative process with axonal injuries that follows demyelination, which are responsible for progressive neurological impairment.

Spinal cord lesions in MS are common, particularly in the cervical spine, and usually occur early in the disease. The first description of cervical spinal cord MS by MRI was performed in 1988 (Honig and Sheremata, 1989). Spinal MS is often associated with concomitant brain lesions; however, as many as 20% of patients with spinal lesions do not have intracranial plaques (Noseworthy et al., 2000).

An increasing amount of evidence suggests that MS is heterogeneous (Compston, 2007). Genetic, immunological and unknown environmental factors are known to

contribute to the development of MS, but a specific cause for this disease is not identified (Compston and Coles, 2002). Potentially, it is the most common cause of non-traumatic neurological disability in young adults and is a tremendous burden for years to come (Compston and Coles, 2002). Any age group can be affected but its peak is in the most economically productive years of life.

MS is more common in temperate climates in people of Northern European descent and it is infrequent in equatorial areas.

Currently, the four major clinical types of MS include relapsing-remitting (RRMS), primary progressive (PPMS), secondary progressive (SPMS) and progressive relapsing (PRMS) (Lublin and Reingold, 1996).

Benign MS is a variant of RRMS where patients remain fully functional in all neurologic systems 10-15 years after disease onset. Clinically isolated syndrome (CIS) is described as the first neurological episode and may or may not progress to clinically definite MS (CDMS).

Neuromyelitis optica (NMO) (Devic's disease) is an MS-like inflammatory demyelinating disease, extensively affecting the spinal cord and optic nerves (Compston and Coles, 2008; Weinshenker et al., 2006; Wingerchuk et al., 2006). Despite many similarities, current data strongly suggest NMO is an entity distinct from MS.

Although progressive neurological disability might be present from the onset of MS, the initial attack of MS is generally mild and self-limiting, but relapsing is common after a variable duration (Crayton et al., 2004).

Diagnosis of MS is based on evidence of the dissemination in space, dissemination in time. History and neurological assessment are the cornerstone for the diagnosis of MS. MRI is the most sensitive method for showing white matter (WM) lesions in

patients suspected of having MS. Lumbar puncture (LP) and clinical neurophysiological tests may be necessary to establish the diagnosis of MS.

So far, there is no curable treatment for MS. Currently approved MS therapeutics have a mainly anti-inflammatory mode of action. The aim of treatment in MS is to reduce the frequency, and limit the lasting effects, of relapses, relieve symptoms, prevent disability arising from disease progression, and promote tissue repair.

The expected future course of the disease mainly depends on subtype. Individuals with progressive subtype, particularly the primary progressive subtype, have a more rapid decline in neurological and cognitive functions. The prognosis in females generally is better than in males. Initial MS symptoms of visual loss or sensory problems are thought to be markers for a relatively better prognosis. In general, one third of patients will still be able to work after 15–20 years of the onset of the disease (Ebers, 2005).

MS is not lethal by itself but death is the result of remarkable disability and disease complications such as repeated respiratory and urinary tract infections.

### **1.1.2 Epidemiology of Multiple Sclerosis**

MS is recognised throughout the world with high prevalence in the Northern Europeans, the North of America and Southern Australia. It is seen less frequently in Asians and is very rare among indigenous people of Africa and Australia (Figure 1.2) Although genetic susceptibility and ethnic group pattern are likely involved, no concrete data have been shown as to why certain regions have a higher incidence of MS (Wallin et al., 2000).

The disease has an incidence of about seven per 100000 every year, prevalence of around 120 per 100000, and lifetime risk of one in 400 (Compston and Coles, 2008).

It has been estimated that within 15 years more than 50% of non-treated MS patients need assistance with their daily household and employment responsibilities

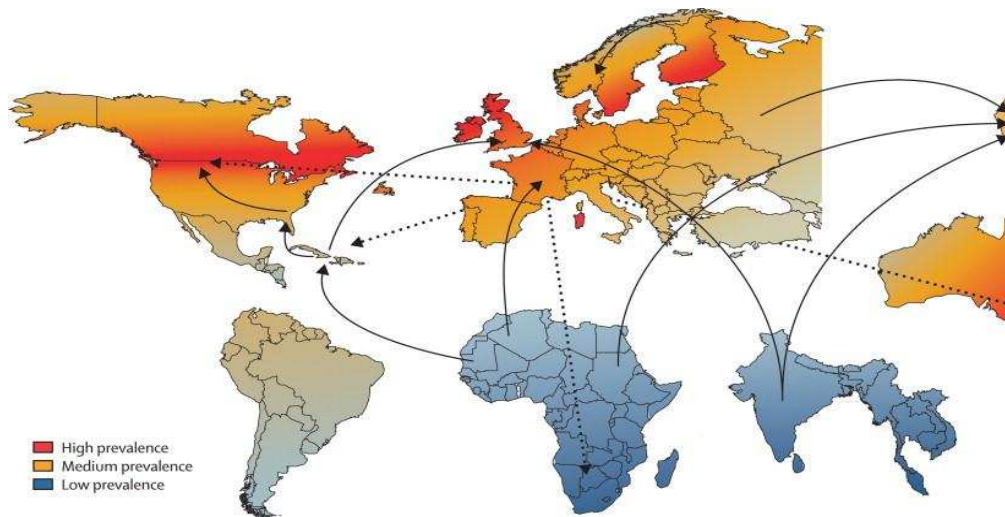

**Figure 1.2 Geography of multiple sclerosis and migration.**

The five continents are depicted to show medium prevalence of multiple sclerosis (orange), areas of exceptionally high frequency (red), and those with low rates (grey-blue). Some regions are fairly uncharted and these colours are only intended to provide an impression of the geographical trends. Major routes of migration from the high-risk zone of northern Europe, especially including small but informative studies, are shown as dotted arrows. Studies involving migrants from low-risk to high-risk zones are shown as solid arrows. Source: (Compston and Coles, 2008).

(Pugliatti et al., 2006). Most of the people with MS usually die of complications such as pneumonia and repeated urinary tract infection rather than of MS itself (especially in bedridden patients) (Ebers, 2005). MS is more common in females, according to Pugliatti's review article the women-to-men ratio for MS in Europe varies from 1.1 to 3.4 (Pugliatti et al., 2006). However recent reports have stated an increase in incidence of MS in women. The basis for this difference is unknown, but hormonal components may be responsible (Debouverie et al., 2007).

### **1.1.3 Pathogenesis of Multiple Sclerosis**

#### **1.1.3.1 Plaque formation**

The mechanisms of the initial pathogenic events leading to plaque formation are controversial (Lucchinetti et al., 2000). The most commonly held view is that the peripherally activated T-cells migrate into the CNS and attack myelin and



oligodendrocytes resulting in production of focal inflammatory lesions (Lassmann et al., 2007). Barnett and Prineas (2004) had an alternative view: they suggested that in some cases the earliest lesions comprise large areas of apoptotic oligodendrocytes, termed fields of dead oligodendrocytes (FoDOs). The pathogenesis of FoDOs is tentative, but could involve humoral factors or oligodendrocyte degeneration in response to viral infection. In any case, the evolution of active lesions involves widespread, focal loss of myelin, the presence of large numbers of activated macrophages digesting myelin degradation products, and a T-cell infiltrate, with CD8+ T-cells predominating (Figure 1.3).

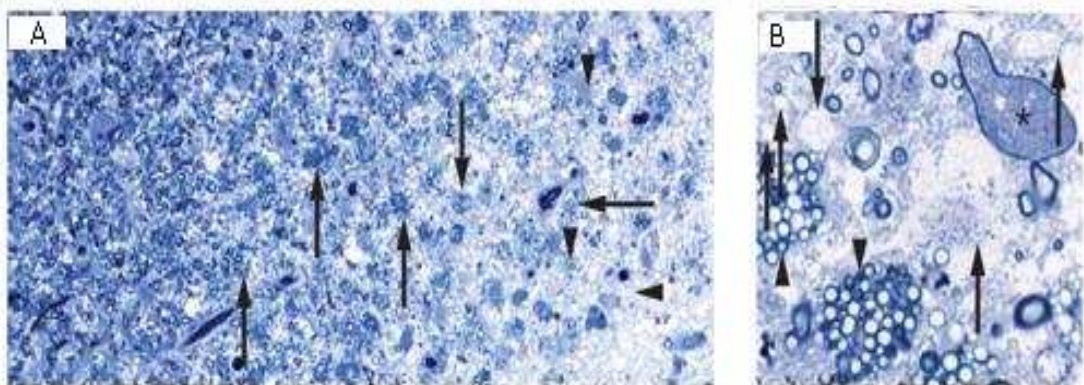

**Figure 1.3 Characteristic brain pathology in multiple sclerosis.**

A / Low-power image of active demyelinating white matter lesion, showing macrophages with myelin degradation products (arrows) and reactive gliosis (arrowheads). B/ Higher-magnification image of the active lesions shown in (A) reveals demyelinated axons (arrows), macrophages with myelin debris (arrowheads) and dystrophic axons (asterisk) within the myelin sheath. Source: (Lassmann et al., 2012).

Although the pathogenesis of MS is not fully understood involvement of cell-mediated immune and humoral immune response to undetermined antigen(s) is doubtless. Pathologically MS is characterized by perivenular and parenchymal infiltration of lymphocytes and macrophages in the parenchyma of the brain, brain stem, optic nerves, and spinal cord. In general the accepted view of MS

pathogenesis has linked the disease course to sensitisation a myelin-specific, CD4+ T lymphocyte in the peripheral in response to macrophage presentation of a foreign antigen in association with major histocompatibility complex (MHC) class I and class II (Höftberger et al., 2004; Wucherpfennig and Strominger, 1995). This results in peripherally activated T cells expressing, and recognising, vascular adhesion molecules facilitating their entry through blood brain barrier (BBB). Inside the CNS activated T cells release pro-inflammatory cytokines resulting in up regulation of local antigen-presenting cells (APC) with the capacity to present self-myelin proteins (Lassmann et al., 2007).

In addition to T cells the autoimmune B cells and humoral immune mechanisms are now believed also to play key roles in the pathogenesis of MS and plaque initiation (Gay and Esiri, 1991; Owens et al., 2006), and demyelination in patients with established MS (Wucherpfennig and Strominger, 1995). This component has been recognised previously in MS diagnosis through the presence of oligoclonal bands (OCB) in the cerebrospinal fluid (CSF) and increased intrathecal Immunoglobulin G (IgG) synthesis (Link and Huang, 2006). Variable degrees of clonally expanded populations of memory B cells and plasma cells are found in lesions and CSF from patients with MS (Bartoš et al., 2007; Magliozzi et al., 2007; Owens et al., 2003). It has been shown that depletion of B-cells in MS lesions results in a reduction in gadolinium enhanced lesions on MRI and reduced relapse frequency (Bar-Or et al., 2008).

#### **1.1.3.2 Neurodegeneration in Multiple Sclerosis**

Besides the inflammatory activity in the CNS the degenerative process in MS appears to start early in the disease (Figure 1.4). Significant brain atrophy has been found in early diagnosed MS patients with little disability (Chard et al., 2002). Atrophy of CNS is most pronounced in the progressive phase of MS, and correlates with the rate of decline in neurological function (Losseff et al., 1996). A study

showed low level of N-acetylaspartic acid (NAA), a marker for axonal damage shown by magnetic resonance spectroscopy (MRS) in MS patients (De Stefano et al., 2002). Pathologically, in these stages, the lesions are characterised by

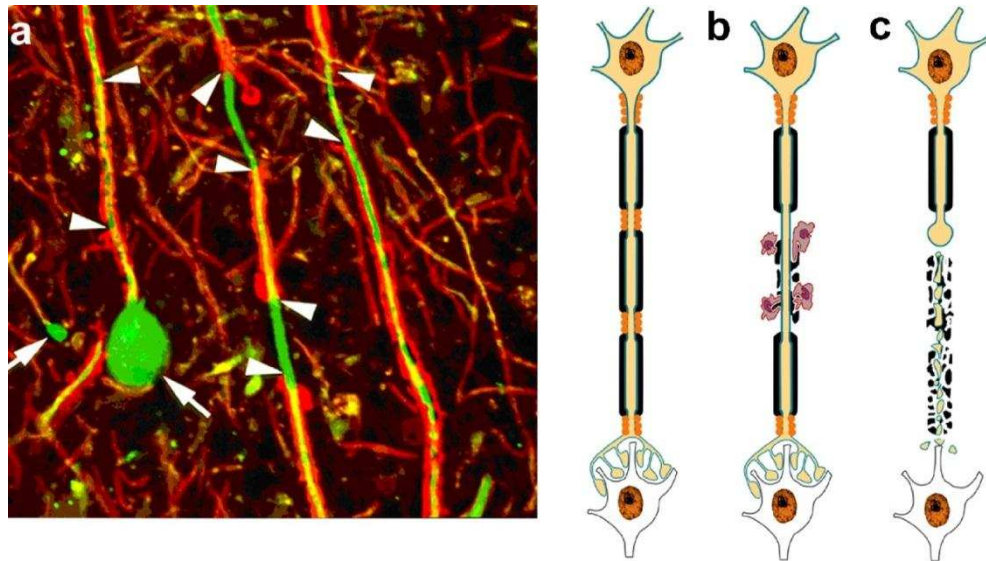

**Figure 1.4 Immune-mediated demyelination and axonal transaction.**

Axonal ovoids are hallmark of transacted axons. Abundant axonal ovoids were detected in MS tissue (a) when stained for myelin protein (red) and axons (green). There are areas of demyelination (arrowheads), mediated by microglia and haematogenous monocytes. One of the axons ends in a large swelling (arrow) or axonal retraction bulb (arrow). (b and c) Schematic of axonal response during and following transaction. Demyelination is an immune-mediated or immune cell assisted process leading to axonal transaction. When transacted, the distal end of the axon rapidly degenerates while the proximal end connected to the neuronal cell body survives and transported organelles accumulate at the transaction site and form an ovoid (arrows). Source: (Trapp and Nave, 2008).

demyelination, activated microglia, apoptotic death of neurons, interlaced with macrophages and myelin debris, making up the glial scar tissue. The lesions have less leukocyte infiltrations and there is marked depletion of oligodendrocytes (Lucchinetti et al., 2003).

### **1.1.3.2.1 Axonal Degeneration in Multiple Sclerosis**

Although the MS lesion includes both inflammatory and demyelinating components their relative influence on axonal loss is unclear. Axonal pathology was mentioned in early reports that included description of axonal swelling, axonal transection and Wallerian degeneration (Kornek and Lassmann, 1999). Some studies have demonstrated a high incidence of acute axonal injury within both early and chronic MS lesions (Ferguson et al., 1997; Kornek and Lassmann, 1999; Trapp et al., 1998). Axonal degeneration occurs in the setting of acute inflammatory demyelination (Trapp et al., 1998) and/or as a consequence of chronic demyelination (Bjartmar et al., 2000; Dutta et al., 2006) (Figure 1.4).

#### **1.1.3.2.1.1 Mechanism of Axonal Degeneration**

##### **1.1.3.3.1.1.1 Axonal degeneration in acute inflammatory process**

The most accepted contributing causal factors for axonal damage in the acute lesions are:

Immune-cell mediated injury: There is a close link between axonal injury and cytotoxic effect of T-cell in human which initiated through direct T cell mediated cytotoxicity with the target axon (Neumann et al., 2002). Axonal transection has been reported in vitro in an antigen dependent immunological reaction with Class I MHC restricted T lymphocytes (Medana et al., 2001). Also the interaction of activated macrophages or microglia cells with axons in the course of axonal injury has been suggested in EAE, such cells are consistently found in close contact with degenerating axons in EAE (Brunn et al., 2008).

Glutamate in acute axonal injury: Increased levels of glutamate after inflammatory injury leads to excess excitatory activation of ionotropic subtypes of glutamate receptors such as  $\alpha$ -amino-3-hydroxy-5-methyl-4-isoxazolepropionic acid (AMPA) receptors. This results in toxic accumulation of intracellular sodium and calcium

during normal electrical activation (Ouardouz et al., 2009). Evidence of increased oligodendrocyte and axonal survival, after treatment with a glutamate antagonist in animal and cellular models, further supports a role for glutamate in acute axonal injury (Pitt et al., 2000).

Nitric oxide and acute axonal injury: Evidence suggests that nitric oxide (NO), which is released from inflammatory cells, at higher concentrations may lead to irreversible destruction of axons (Smith et al., 2001). Also it has been reported that NO may even directly damage nerve cell bodies and dendrites and can play a role in demyelination and oligodendroglia damage (Bolanos et al., 1997).

#### **1.1.3.3.1.1.2 Progressive axonal damage in chronic plaques**

The most accepted contributing causal factors for axonal damage in the chronic plaques are:

Remyelination failure: In vitro, trophic factors such as insulin-like growth factor-type 1 (IGF-1) which is a polypeptide growth factor similar in structure to insulin and neuregulin provided by oligodendrocyte promote normal axon function and survival to axons. Lack of these factors in chronic lesion result in neurodegeneration and death of the axons (Compston, 1996; Wilkins and Compston, 2005).

Conduction defects: Axonal conduction is a continuous energy dependent process that is essential for maintaining cell function. Demyelination disrupts axonal conduction. Studies have shown that conduction defects along chronically demyelinated axons contribute to the progression of neurological disability (Kornek et al., 2001; Waxman, 2001).

Toxic level of intracellular calcium: Studies have shown that stimulation of glutamate receptors results in  $\text{Ca}^{2+}$  influx from both the extracellular space, and from ryanodine-dependent intracellular stores. The processes result in abnormally increased intracellular levels of  $\text{Ca}^{2+}$  that culminates in the activation of degradation

enzymes, inhibition of mitochondrial function and cellular death (Ouardouz et al., 2009; Trapp and Stys, 2009).

### **1.1.3.3 Gray Matter lesions in Multiple Sclerosis**

MS is generally believed to be a WM disease but conclusions from advanced MRI techniques and histopathological findings have indicated prominent gray matter (GM) changes suggestive of both demyelination and axonal damage. These have been detected in MS cortical lesions (Chard et al., 2002). Generally, GM lesions are a more prominent feature of PPMS and SPMS, where they can be extensive, suggesting it is a predominantly late phenomenon in MS pathology (Kutzelnigg et al., 2005). However, it is also documented that cortical lesions are present from the earliest stages of MS, accumulate over time, and exceed WM lesions in progressive MS (Brownell and Hughes, 1962; Lassmann and Lucchinetti, 2008). Pathologically the lesions are characterised by demyelination, activated microglia, apoptotic death of neurons, and have less leukocyte infiltrations. Furthermore it is believed that cortical plaques have important role in contributing to the disease burden in patients with MS (Peterson et al., 2001).

### **1.1.4 Clinical courses of Multiple Sclerosis**

MS is divided into four clinical subtypes (Lublin and Reingold, 1996) (Figure 1.5).

Relapsing-remitting MS: It is defined as more than one clinical attack of demyelination, that is an initial episode followed by at least one (relapse), separated by period(s) of complete or partial recovery (remission). Approximately 80-85% of patient with MS have RRMS at the onset.

Secondary progressive MS: It is the stage that follows RRMS; symptoms are continuous and gradually worsen, without remission. Relapses may occur, but less frequent than in the RR phase. After several years about 50% of patients with RRMS progress into SPMS (Rovaris et al., 2006).

Primary progressive MS: less than 20% people with MS experience continuous worsening from disease onset with no preceding relapses, although relapses may subsequently occur, but at low frequency.

Progressive relapsing MS: It is an uncommon form of MS characterised by acute relapses superimposed on progressive course.

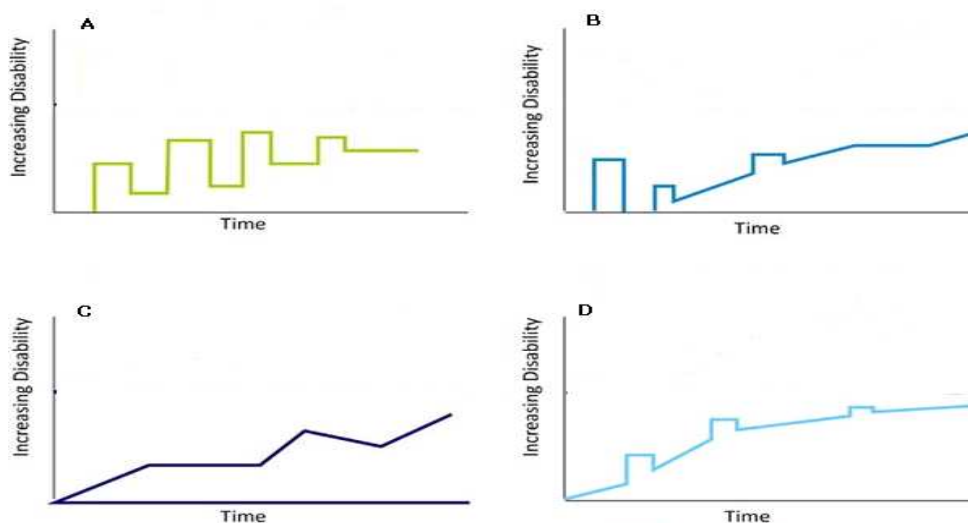

**Figure 1.5 Clinical courses of multiple sclerosis.**

A/ Relapsing/remitting multiple sclerosis: Clearly-defined disease relapses with full recovery or with sequel and residual deficit upon recovery; periods between disease relapses characterised by a lack of disease progression. B/ Secondary progressive multiple sclerosis: Initial relapsing/remitting disease course followed by progression with or without occasional relapses, minor remissions or plateaux. C/ Primary progressive multiple sclerosis: Disease progression from onset, with occasional plateaux and temporary minor improvements. D/ Progressive-relapsing multiple sclerosis: Progressive disease from onset, with clear acute relapses, with or without full recovery.

### 1.1.5 Clinical Features of Multiple Sclerosis

Clinical features of MS are varied and capricious, depending on location and degree of the lesions affecting the CNS (Table 1.1). Symptoms start with beginning of interruption of myelinated tracts in the CNS. Insidious or abrupt weakness in one or more limbs, a sensory disturbance, monocular visual loss (optic neuritis), double vision (diplopia), gait instability, and ataxia are the possible initial symptoms of MS.

Early symptoms may be severe or trivial. With progression of the disease bladder dysfunction, heat intolerance and fatigue occur in most patients. Additional

**Table 1.1 Clinical features of multiple sclerosis.** Source: (Compston and Coles, 2008)

Cerebrum	Cognitive impairment	Deficits in attention, reasoning, and executive function (early); dementia (late)
	Hemisensory and motor	Upper motor neuron signs
	Affective (mainly depression)	
	Epilepsy (rare)	
	Focal cortical deficits (rare)	
Optic nerve	Unilateral painful loss of vision	Scotoma, reduced visual acuity, colour vision, and relative afferent pupillary defect
Cerebellum and cerebellar pathways	Tremor	Postural and action tremor, dysarthria
	Clumsiness and poor balance	Limb incoordination and gait ataxia
Brainstem	Diplopia, oscillopsia	Nystagmus, internuclear and other complex ophthalmoplegias
	Vertigo	
	Impaired swallowing	Dysarthria
	Impaired speech and emotional lability	Pseudobulbar palsy
	Paroxysmal symptoms	
Spinal cord	Weakness	Upper motor neuron signs
	Stiffness and painful spasms	Spasticity
	Bladder dysfunction	
	Erectile impotence	
	Constipation	
Other	Pain	
	Fatigue	
	Temperature sensitivity and exercise intolerance	



symptoms include Lhermitte's symptom, hemifacial weakness, vertigo, and tonic spasms and other paroxysmal symptoms. Cognitive deficits commonly occur in late onset. Depression and suicide ideation are more common than in age-matched controls (Compston and Coles, 2008).

### **1.1.6 Disabilities in Multiple Sclerosis**

MS is associated with physical and cognitive disabilities. They have clear impact on quality of life (QoL) (Janardhan and Bakshi, 2000). Several scales are used to measure disability in MS such as expanded disability status scale (EDSS), The Guy's Neurological Disability Scale (GNDS), Multiple sclerosis severity score (MSSS), paced auditory serial addition test (PASAT), symbol digit substitution test (SDT), multiple sclerosis functional composite (MSFC), etc.

#### **1.1.6.1 Physical Disabilities**

MS Patients vary in the severity of their illness from no obvious physical disability to being severely disabled. It has become increasingly important both in the clinical setting and in therapeutic trials to measure disability levels repeatedly in order to assess progression of disability. The EDSS is a gold-standard measure for assessing level of disability (Kurtzke, 1983). It is an ordinal scale with 19 disease steps between 0 and 10 (Appendix 3) The scale measures activity limitation based on the examination of eight functional systems (pyramidal, cerebellar, brainstem, sensory, bowel and bladder, visual, cerebral, other) plus ambulation. It does have some well documented limitations, the most important of which are: it is biased towards locomotor function, not a sensitive measure to define irreversible progression of disease and has only moderate inter- and intra-rater reliability (Ebers et al., 2005; Sharrack et al., 1999). To address this limitations Sharrack and Hughes established a new disability scale, Guy's Neurological Disability Scale (GNDS), which is a simple clinical disability scale capable of embracing the whole range of disabilities which could be encountered in the course of MS (Sharrack and Hughes,

1999). Identification of sustained disability progression is an important outcome measure in therapeutic trials in MS. An increase of 1 point on the EDSS above baseline (or 1.5 EDSS points if the baseline EDSS is 0), subsequently confirmed at repeat assessment either 3 or 6 months later are the most commonly used measures (Kappos et al., 2006b). Clinically important change in the EDSS was deemed to be 1 point change in the range 0–5.0 and 0.5 point change in the range 5.5–8.5. There are some difficulties with these definitions; relapses may produce neurological changes persisting for many months still followed by full recovery and people with RRMS exhibit day-to-day fluctuation in neurological signs and symptoms unrelated to relapses (Leary et al., 2005). EDSS does not take into account the important aspect of disease duration, which is a major factor in accumulation of CNS damage over time and the accumulation of functional disability. To address this deficiency, Roxburgh with his colleagues based on databases from 11 countries have introduced the MSSS as a method for comparing disease progression in MS using single assessment at a single point in time (Roxburgh et al., 2005).

#### **1.1.6.2 Cognitive Disabilities**

Cognitive dysfunction is common in MS. It does not strongly correlate with the physical disability and EDSS score (Miller et al., 1998). Cognitive impairments are evident in tests measuring attention, vigilance, processing speed, working memory and executive function. Tests such as PASAT, SDT and MSFC are useful tools to detect cognitive disability progression in MS and they are sensitive to change over time.

## **1.1.7 Fatigue in Multiple Sclerosis**

### **1.1.7.1 Definition and overview**

As fatigue is a subjective feeling, there is no unique definition for fatigue. Initially, fatigue in MS has been defined as "an abnormal sense of tiredness or lack of energy, out of proportion to the degree of effort or level of disability, that significantly interferes with routine physical or intellectual functioning" (Weinshenker et al., 1992). The UK Multiple Sclerosis Society defines MS fatigue as "an overwhelming sense of tiredness for no apparent reason." Krupp has described fatigue as an overwhelming sense of tiredness that is out of proportion to "normal" tiredness (Krupp, 2006). Medically, fatigue in MS has been defined as a "reversible, motor and cognitive impairment with reduced motivation and desire to rest, either appearing spontaneously or brought on by mental or physical activity, humidity, acute infection and food ingestion. It can occur at any time but is usually worse in the afternoon. In MS, fatigue can be daily, has usually been present for years and has greater severity than any premorbid fatigue" (Mills and Young, 2008). Fatigue is one of the most common symptoms in patients with MS. It is reported that 50% to 92% of patients with MS experience significant fatigue (Kaynak et al., 2006; Lerdal et al., 2007; Zajicek et al., 2010). It has been described as chronic and the most debilitating feature of the disease by 15% to 40% of MS patients (Fisk et al., 1994b; Giovannoni, 2006; Krupp, 2003).

Fatigue has a significant negative impact on daily work, family life, and social activities of persons with MS and is associated with the perception of an impaired general health, mental state (Janardhan and Bakshi, 2002; Ritvo et al., 1996). The majority of patients with MS experience worse fatigue when temperature is higher, especially those with severe fatigue (Leavitt et al., 2012; Lerdal et al., 2007), and clearly carries a major physical and psychological burden, especially when completing everyday tasks (Leocani et al., 2008; Mills and Young, 2008). MS

patients often report specific triggers for fatigue, such as heat (Krupp and Christodoulou, 2001).

The common fatigue symptoms are: reduced energy, malaise, motor weakness during sustained activity, and difficulty maintaining concentration. Fatigue is diagnosed when the presence of fatigue symptoms lasts for at least 50% of days for more than 6 weeks (Multiple Sclerosis Clinical Practice Guideline, 1999). Self-report questionnaires such as the fatigue severity scale (FSS) may be useful in the diagnosis of MS fatigue and as a surrogate outcome measure.

Fatigue in MS may manifest itself in a variety of forms, including acute fatigue localized to specific muscle groups and persistent, global fatigue. Fatigue affects both motor and cognitive ability.

### **1.1.7.2 Types of Fatigue**

#### **1.1.7.2.1 Motor Fatigue**

Motor fatigue is defined as a decline in motor performance during sustained muscle activity (Bigland-Ritchie et al., 1998). Motor fatigue worsens during MS exacerbations involving the motor system and improves during remission, but does not change during exacerbations in which the motor system is unaffected (Djaldetti et al., 1996). Studies have found that motor fatigue during intermittent voluntary submaximal contractions of the tibialis anterior muscle was associated neither with self-reported fatigue in MS patients nor with overall neurologic impairment/disability, but it was associated with pyramidal signs on examination (Djaldetti et al., 1996; Sharma et al., 1995). The pathophysiologic basis for motor fatigue in MS patients remains unclear. Both peripheral and central mechanisms have been suggested. Studies using transcranial magnetic stimulation have suggested that there may be decreased central activation as fatigue occurs in MS patients (Brasil-Neto et al., 1994; Sheean et al., 1997). On the other hand studies focusing on exercise-induced

biochemical changes in muscle have suggested that peripheral mechanisms are involved, producing alterations in muscle metabolism (Hainut and Duchateau, 1989; Kent-Braun et al., 1994; Miller et al., 1990).

#### **1.1.7.2 Cognitive fatigue**

Cognitive fatigue can be defined as a decrease in, or inability to sustain, task performance throughout the duration of a continuous information processing speed task (Schwid et al., 2002). Cognitive fatigue can occur in all stages of the disease and usually does not correlate with demographic or disease characteristics such as age, gender, depression, disability or disease severity, or disease duration (Parmenter et al., 2003).

Comparing with healthy control, during continuous information processing speed task patients with MS become cognitively fatigued sooner, reflected by a breakdown in task performance (Bryant et al., 2004).

#### **1.1.7.3 Measurement of Fatigue**

Available measurements for fatigue so far are; FSS, Fatigue Descriptive Scale (FDS), Modified Fatigue Impact Scale (MFIS), Neurological Fatigue Index (NFI-MS) and Visual Analogue Scale for Fatigue (VAS-F) (Johnson, 2008). These measures are mainly self-report questionnaires, and they are not specific to MS. One of the most commonly used self-report scales is FSS, which is a self-report questionnaire designed to assess fatigue in general (Krupp et al., 1989). It has shown that FSS has ability to highlight the approach towards appropriate and individualised treatments (Valko et al., 2008).

#### **1.1.7.4 Pathogenesis of MS fatigue**

The exact aetiology and pathophysiology of fatigue in MS patients are not well understood, it appears to be complex and multifactorial. Both peripheral and central mechanisms have been suggested but no satisfactory conclusion has been

achieved so far (Kos et al., 2008). Fatigue may be directly related to the underlying MS disease process and the disease mechanisms such as proinflammatory cytokines, CNS lesion load, cerebral quantitative imaging abnormalities and patterns of cerebral activation, endocrine influences and axonal injury (primary fatigue), [reviewed in (Induruwa et al., 2012)] or may be secondary to non-disease-specific factors such as secondary effects of inflammation on neuromodulation, disruption of neural pathways necessary for brain activity, and daytime somnolence due to nocturnal sleep disturbances such as sleep problems, urinary problems, spasms, pain, anxiety or depression (secondary fatigue) (Bakshi, 2003; Krupp, 2003; Schwid et al., 2002). MS fatigue has not been shown to be correlated with disease duration, gender, psychosomatic mechanisms, physical disability, or sleep dysfunction. A study has showed that obvious fatigue has been observed in patients with benign MS with no disability and it was also showed that MS fatigue is not related to some markers of systemic inflammation (Giovannoni et al., 2001).

A study by Bakshi et al. showed a significant relationship between fatigue and depression in MS independent of physical disability (Bakshi et al., 2000). Kaminska et al (2011) have found that sleep disturbances in MS may also result in or exacerbate fatigue in MS.

Using conventional MRI, only a weak correlation between MRI lesion load and fatigue has been reported (Bakshi et al., 1999; Colombo et al., 2000). In contrast, by using more advanced MRI techniques other studies have found that GM pathology (Cantor, 2010) and the basal ganglia (Télléz et al., 2008) may be a contributing factor to the development of MS related fatigue. The results of the Niepel et al study had supported the role of the GM in the pathogenesis of fatigue in MS (Niepel et al., 2006). The relationship between MS fatigue and brain atrophy has been suggested by several studies. Yaldizli et al (2011) have found that corpus callosum (CC) atrophy was present in subjects with MS and may play a role in the evolution of MS-

related fatigue. Other studies have suggested that patients with higher levels of fatigue have higher WM and GM atrophy (Marrie et al., 2005; Pellicano et al., 2010; Tedeschi et al., 2007). In a comparative study with healthy control a strongest correlation between cortical atrophy and fatigue in the MS patient has reported (Pellicano et al., 2010).

It has been found that the fatigued MS patients have significantly increased adrenocorticotrophic hormone (ACTH) levels in the combined dexamethasone-corticotrophin releasing hormone (Dex-CRH) test, compared to those without fatigue (Gottschalk et al., 2005). In a similar study with 73 progressive MS patients, Téllez et al. proposed that fatigue could be related to low serum levels of dehydroepiandrosterone (Tellez et al., 2006). There is also evidence suggest that increased activation of central neural circuits is associated with MS fatigue. Several studies have suggested that performing motor function increases loss of strength and increased cortex excitability in a wider cerebral area than in control subjects and led to early fatigue (Benwell et al., 2007; Leocani et al., 2001; Thickbroom et al., 2008).

Axonal damage is also suggested as being a factor for fatigue in MS. A study by Tartaglia et al used MRS, found that the N-acetyl aspartate (NAA): Creatinine (NAA/Cr) ratio used as marker of CNS axonal damage was significantly lower in a high-fatigue than in a low-fatigue group of MS patients. There was also a significant inverse linear correlation between the FSS scores and the NAA/ Cr ratio (Tartaglia et al., 2004).

#### **1.1.7.5 Management of fatigue**

Fatigue in MS is different from fatigue in healthy subjects and it is one of the most challenging symptoms to treat (Krupp et al., 2010). Despite various non-pharmacological and pharmacological treatments or combinations trials definitive evidence of their relative efficacy and tolerability is unavailable.

#### **1.1.7.5.1 Non-pharmacologic therapies**

Non-pharmacological approaches include aerobic exercise programmes, energy conservation strategies and cognitive behavioural therapy (CBT). The benefit of cooling therapies has been tested which been reported to be effective in reduction of fatigue and improvements in physical, cognitive, and psychosocial function (Flensner and Lindencrona, 2002). Improvement of sleep has been evaluated to treat fatigue in MS (Heesen et al., 2006) . Aerobic exercise program found to be effective in reduction of MS fatigue and improvement of health (Mostert and Kesselring, 2002).

The use of CBT to treat fatigue in MS is still under investigation. A randomised control trial of patients with MS related fatigue receiving either CBT or relaxation therapy showed that at 6 months after treatment, both groups described clinically significant decreases in fatigue levels equivalent to those of the healthy comparison group (van Kessel et al., 2008).

#### **1.1.7.5.2 Pharmacologic Drug therapy**

Several medications have been tried for treatment of fatigue in MS. Amantadine is a dopaminergic agent that has been evaluated for fatigue. A significant efficacy on some of the studies, but not all, has been found (Cohen and Fisher, 1989; Krupp et al., 1995; Murray, 1985; Rosenberg and Appenzeller, 1988). Modafinil is a wake-promoting agent has been studied in patients with MS, and was effective on several measures of fatigue (Rammohan et al., 2002; Zifko et al., 2002). Aminopyridines are potassium channel-blocking agent exert their effect through enhancing conduction in demyelinated nerve fibres. Its effects on MS fatigue have been suggested but not definitively demonstrated (Rossini et al., 2001; Schwid et al., 1997).

Improvement of fatigue score in MS patients by Prokarin, which is a proprietary blend of histamine and caffeine, has been found in a placebo controlled study



(Gillson et al., 2002). Metz et al. have provided evidence that MS fatigue may be improved with immune modulating treatment with either glatiramer acetate (GA) or interferon beta (IFN- $\beta$ ), shown by improved total fatigue impact scale (FIS) scores (Metz et al., 2004).

### **1.1.8 Autonomic dysfunction in multiple sclerosis**

Autonomic dysfunction (AD) in people with MS is well documented, but, the significance of these abnormalities and the relationship to clinical characteristics is not yet established (Flachenecker et al., 2003; Merkelbach et al., 2001).

AD particularly affects the bladder, bowel, cardiovascular function, sleep, sexual and sweat glands. This may be clinically evident such as bladder disturbances or may be subclinical, when abnormal sympathetic skin response (SSR) or decreased heart rate variation is estimated (Linden et al., 1995; Linden et al., 1997).

AD has an important impact on the disability in MS patients and is considered as one of the crucial components that have an impact on the QoL outcomes in these patients.

The pathophysiology behind AD remains unclear but plaques located adjacent to the pathways significant for autonomic function in the hypothalamus involving fornix, anterior commissure, internal capsule, optic system and spinal cord might be the basis for autonomic disturbances in MS patients (Huitinga et al., 2001). It has been suggested that demyelination may disrupt the central autonomic network in the insular, anterior cingulate and ventromedial prefrontal cortices, central nucleus of the amygdala, paraventricular hypothalamus and the medulla or interfere with the descending autonomic nervous system (ANS) pathways during their course in the brainstem or spinal cord (Vita et al., 1993).

The autonomic nerve activity is not assessed directly, but the response of the effector organs can be measured. Electrophysiological evaluations for assessing AD

in MS patients has been established as a diagnostic tool for AD, some studies have suggested the use of some self-completed questionnaires on the symptoms of patients with AD (Flachenecker et al., 2001; Nasser et al., 1999).

AD may not only be a consequence of the disease but may also in itself play a pathogenetic role; evidence from animal and clinical studies suggest interactions between the immune system and the ANS (Chelmicka-Schorr and Arnason, 1994; Zoukos et al., 1994).

### **1.1.9 Diagnosis of Multiple Sclerosis**

Diagnosing MS is complex and sometimes lengthy process. Clinical findings and supporting evidence from supplementary tests, such as MRI of the brain, CSF examination, and clinical neurophysiology are the bases for diagnosis of MS. Clinical ground is a cornerstone for diagnosis of MS. MRI has become a valuable test for confirming the probable cases of MS. The diagnosis depends on detection of lesions which are disseminated in time and space. CSF examination is used for detection of OCBs and IgG level in the CSF. Finally the clinical neurophysiology has a role in supporting the diagnosis especially the visual and somatosensory evoked potentials, which are helpful in identifying additional, silent lesions (Polman et al., 2005b).

#### **1.1.9.1 Diagnostic Criteria for Multiple Sclerosis**

##### **1.1.9.1.1 The Poser criteria**

In 1983 Poser with his colleagues established a new diagnostic criteria for MS (Poser et al., 1983):

Clinically definite MS

2 attacks and clinical evidence of 2 separate lesions

2 attacks, clinical evidence of one and paraclinical evidence of another separate lesion

Laboratory supported Definite MS

2 attacks, either clinical or paraclinical evidence of 1 lesion, and CSF immunologic abnormalities

1 attack, clinical evidence of 2 separate lesions & CSF abnormalities

1 attack, clinical evidence of 1 and paraclinical evidence of another separate lesion, and CSF abnormalities

Clinically probable MS

2 attacks and clinical evidence of 1 lesion

1 attack and clinical evidence of 2 separate lesions

1 attack, clinical evidence of 1 lesion, and paraclinical evidence of another separate lesion

Laboratory supported probable MS

2 attacks and CSF abnormalities

#### **1.1.9.1.2 The McDonald criteria**

In 2001 an international panel in association with the National Multiple Sclerosis Society of America recommended revised Diagnostic criteria of MS. They make use of advances in MRI imaging techniques in order to facilitate in diagnosis of MS and using MS, possible MS or not MS (McDonald et al., 2001). Currently, McDonald criteria are regarded as the gold standard for MS diagnosis (Appendix 2).

##### **1.1.9.1.2.1 Revised 2005**

The McDonald criteria were revised in 2005 to clarify some terms such as exactly what is meant by an "attack," "dissemination," a "positive MRI," etc. (Polman et al., 2005b) (Appendix 4).

#### **1.1.9.1.2.2 Revised 2010**

In 2010, the International Panel on Diagnosis of MS revised the McDonald diagnostic criteria. This revision had simplified the demonstration of CNS lesions in space and time by MRI techniques and made the criteria for all people including the non-Western Caucasian populations (Polman et al., 2011) (Appendix 5).

#### **1.1.10 Treatment of Multiple Sclerosis**

MS is a progressive disease that has no cure. Treatment categories are:

- Acute treatment
- Disease-modifying therapies
- Combination therapies
- Investigational Therapies
- Symptomatic therapy,
- Neuroprotective agents

##### **1.1.10.1 Acute Treatment**

Treatment of acute attacks will shorten the duration and possibly decrease the severity of the attack.

Corticosteroids: Corticosteroids are a mainstay of treatment for acute exacerbations associated with MS. The most commonly used corticosteroids are methylprednisolone and prednisone. There are several potential modes of action, which include reducing oedema, stabilising the BBB, decreasing pro-inflammatory cytokines, and T cell apoptosis (Gold et al., 2001).

Plasmapheresis: Patients have been treated with plasmapheresis for acute, severe attacks, were reported to exhibit moderate or marked functional improvement after the initial treatment. In cases steroids are contraindicated or not effective, plasma

exchange can be an alternative for short term use in severe attacks (Meca-Lallana et al., 2003; Weinshenker, 2001).

The 2011 American Academy of Neurology (AAN) guideline confirms that plasmapheresis is probably effective in relapsing forms of MS as second-line treatment for exacerbations that resist steroid treatment.

#### **1.1.10.2 Approved disease modifying therapies**

The disease modifying therapies (DMT) for MS currently approved for use in relapsing forms of MS include the following:

Interferons (INF): INFs are natural proteins that are produced by the body in response to infectious stimuli. They were first described in 1957. Based on the type of receptor through which they signal, human INFs have been classified into three major types: INF type I; bind to a specific cell surface receptor complex known as the INF-  $\alpha$  receptor. The type I INFs present in humans are IFN- $\alpha$ , IFN- $\beta$  and IFN- $\omega$ . INF type II: Binds to interferon-gamma receptor. In humans this is IFN- $\gamma$ . INF type III: Signal through interleukin 28 receptor, alpha subunit (Papatriantafyllou, 2013). The INF currently approved for treatment of MS are INF  $\beta$ -1b (Betaseron, Extavia) and INF  $\beta$ -1a (Rebif1, Avonex). INF  $\beta$  has been shown to inhibit T-cell activation and reduce BBB permeability to inflammatory cells, Pivotal phase III studies of INF  $\beta$  have all demonstrated a significant reduction in relapse rate and improvement in MRI measures of disease activity in RRMS (Ebers, 1998; Jacobs et al., 1996; The Ifnb Multiple Sclerosis Study Group, 1993).

Glatiramer Acetate (GA) : In experimental models, the immunomodulatory mechanism of action for GA involves binding to MHC molecules and consequent competition with various myelin antigens for their presentation to T cells (Arnon and Aharoni, 2004). In addition, GA is a potent inducer of specific T helper 2 type

suppressor cells that migrate to the brain and lead to bystander suppression; these cells also express anti-inflammatory cytokines.

The benefit of GA was first established in patients with RRMS. Two placebo-controlled studies have shown that GA significantly lowered relapse rate (Johnson et al., 1995), and significantly reduced disability progression (Johnson et al., 1998) as compared to the placebo. Another trial found that GA treatment led to a significant reduction in the number of new T2 lesions on brain MRI (Comi et al., 2001a). A recent head-to-head comparison trial (Betaferon / Betaseron vs. GA) (O'Connor et al., 2009) has shown largely similar efficacy between the INF  $\beta$  treatments and GA.

Mitoxantrone (Novantrone): Mitoxantrone is an antineoplastic drug. USA food and drug administration (FDA) has approved this drug for patients suffering from secondary-progressive, progressive-relapsing, or worsening RRMS. Mitoxantrone decreases proinflammatory cytokines, augments suppressor cell function and decreases the migration of T cells into the CNS by suppressing the activity of T cells, B cells, and macrophages. In Progressive MS mitoxantrone can alter the disease course and also suggested benefit in the treatment in RRMS (Mahdavian et al., 2010).

Natalizumab (Tysabri): Natalizumab is a monoclonal antibody against the cell adhesion molecule  $\alpha$ 4-integrin. It inhibits the migration of T and B cells into the CNS, resulting in a reduction of inflammatory demyelinating lesions. Natalizumab can slow the disease progression and decreases the number of relapses (Mahdavian et al., 2010). An uncommon, but potentially deadly, side effect of treatment of MS patients with natalizumab is the development of progressive multifocal leukoencephalopathy (PML). Clinically, PML manifests with subacute progressive cognitive decline and focal neurological deficits, and it is usually fatal (Sahraian et al., 2012).

Fingolimod: In 2010, fingolimod became the first oral DMT approved for treatment of MS and categorized in a new class called sphingosine 1-phosphate receptor (S1P-R) modulators. This S1P-R modulator deprives T cells of the signal they need to leave lymph nodes, thus inhibiting them from circulating and entering the brain. Studies have found that fingolimod reduces the number of lesions detected on MRI and clinical disease activity in patients with MS (Kappos et al., 2006a; Mahdavian et al., 2010).

Teriflunomid: Teriflunomide is an oral reversible inhibitor of dihydroorotate dehydrogenase (DHODH), a mitochondrial membrane protein essential for pyrimidine synthesis (Palmer, 2010). DHODH blocks de-novo pyrimidine synthesis leading to an inhibition of the proliferation of autoreactive B and T cells. In the presence of teriflunomide, replication of hematopoietic and memory cells is preserved through metabolism of the existing pyrimidine pool. Teriflunomide has been shown to have modulation of immunoglobulin class switching, IL-2 production, and IL-2 receptor expression (Siemasko et al., 1996)

Teriflunomide was compared with placebo in a phase II trial in patients with RRMS and SPMS still experiencing relapses. Patients who received teriflunomide had significantly fewer T1-enhancing lesions or new or enlarging T2 lesions than those treated with placebo. Patients receiving teriflunomide had significantly reduced T2 disease burden. The proportion of patients with increased disability by EDSS at 36 weeks was significantly lower with teriflunomide compared with placebo (O'Connor et al., 2006)

Two phase II studies evaluated teriflunomide as adjunctive therapy in persons with MS (Freedman et al., 2010; Freedman et al., 2009). In these studies, patients receiving glatiramer acetate or a  $\beta$ -IFN were randomised to add placebo or teriflunomide their current therapy. In both studies, teriflunomide had good safety and tolerability and was associated with improved disease control manifested as

reduced number and volume of T1 gadolinium-enhancing lesions, compared with placebo.

Results from the phase III, TEMSO study demonstrated significant reduction in annualized relapse rate (ARR) and disability progression with teriflunomide compared with placebo (Miller et al., 2012). The numbers of gadolinium-enhancing T1 lesions and unique active lesions per scan were also reduced with teriflunomide vs. placebo (Nelson et al., 2011).

Teriflunomide is also being evaluated as an adjunctive therapy in combination with IFN- $\beta$  in the phase III, TERACLES study, with estimated completion in 2014. Two additional studies are underway; TOWER and TENERE are monotherapy studies comparing teriflunomide with placebo and IFN- $\beta$ -1a subcutaneous, respectively (ClinicalTrials.gov., 2011a). TOPIC is an ongoing phase 3 trial evaluating the efficacy and safety of once daily teriflunomide vs. placebo in patients with clinically isolated syndrome (ClinicalTrials.gov., 2011b).

BG-12 (Dimethyl Fumarate): BG-12 is a fumaric acid ester with immunomodulatory properties. BG-12 has demonstrated benefits in animal models of EAE. Fumaric acid esters may decrease leukocyte passage through the BBB and exert neuroprotective properties by the activation of antioxidative pathways (Lee et al., 2008).

DEFINE was a phase III, placebo-controlled, comparative study of BG-12 in RRMS patients (Gold et al., 2012). Patients were randomised to BG-12 at two different doses or to placebo. Both BG-12 doses were associated with a significant decrease in the proportion of patients who relapsed at 2 years compared with placebo. Both BG-12 doses were significantly superior to placebo in reducing ARR, the number of new or newly enlarging T2 hyperintense lesions, and the number of new gadolinium-enhancing lesions. BG-12 was also superior to placebo in slowing



the rate of disability progression as measured by EDSS scores at 2 years (Gold et al., 2012).

CONFIRM was a phase III, study, investigated the efficacy and safety of oral BG-12, at two different doses, as compared with placebo in patients with RRS. An active agent, glatiramer acetate, was also included as a reference comparator. In patients with RRMS, BG-12 (at both doses) and glatiramer acetate significantly reduced relapse rates and improved neuroradiologic outcomes relative to placebo (Fox et al., 2012).

### **1.1.10.3 Combination therapies**

The combinations of intravenous (IV) methylprednisolone and methotrexate with intramuscular (IM) INF  $\beta$ -1a have been tested in clinical trials (Cohen et al., 2008; Cohen et al., 2009). The results have revealed a non-significant trends favouring IV methylprednisolone for new or enlarging T2-hyperintense lesions, gadolinium-enhancing lesions, relapse rate, EDSS change, MSFC score change, and a combined measure of clinical and MRI disease activity. The benefit of methotrexate has not been suggested.

The results of another clinical trial of oral methylprednisolone as add-on therapy to INF  $\beta$ -1a for the treatment of RRMS (Sorensen et al., 2009) have suggested that the mean yearly relapse rate was less in the methylprednisolone group compared to the placebo group while EDSS progression was not significantly different between the two groups.

Calabresi et al (2002) in a pilot study have investigated the effect of adding methotrexate to INF  $\beta$ -1a in MS patients. They found a significant reduction in gadolinium-enhancing lesion number and mean relapse number. A similar open-label trial had investigated the combination of azathioprine with INF  $\beta$ -1a (Pulicken et al., 2005) found a reduction in gadolinium-enhancing MRI lesions.

Combination of IM INF  $\beta$ -1a with IV natalizumab has been studied in a clinical trial where it was found that the risks of relapse, number of new or enlarging T2-hyperintense lesions, and mean number of gadolinium-enhancing lesions were significantly lower in the natalizumab group than in the placebo group. This was a largest combination trial so far and data from this trial indicated a clear advantage of natalizumab plus intramuscular INF  $\beta$ -1a over intramuscular INF  $\beta$ -1a alone on clinical and imaging endpoints (Rudick et al., 2006).

A monthly infusion of IV natalizumab along with GA has been evaluated in a clinical trial. The results have indicated that combination group had superiority compared to placebo group for the primary and most secondary imaging outcomes (Goodman et al., 2009).

In some pilot studies a short course of mitoxantrone is used to induce immunosuppression, followed by immunomodulation with first-line drugs such as INF- $\beta$  or GA. These trials have suggested a promising findings with both drugs [reviewed in (Boggild, 2009)].

Despite evidence from many preliminary studies that lends support to the safety, tolerability, and efficacy of several combination regimens, many of larger trials of these combinations have yielded negative or conflicting results. Combination therapy remains an attractive option in MS treatment, however, the neuroprotection strategy in MS was rarely studied. The future efforts should focus on combining anti-inflammatory and neuroprotective or reparative strategies.

### **Investigation therapies in multiple sclerosis**

Research into additional treatment options continues to advance. Multiple approaches are being investigated based on the increasing knowledge about immune system abnormalities and CNS lesion formation in MS. These include

approaches to counteract or reduce immune system activation, BBB disruption, neuronal loss and myelin loss.

The development of new pharmacologic agents for the treatment of MS has led to changes in the treatment of MS. To date, six drugs have entered or completed phases II and III clinical trials. These include laquinimod, alemtuzumab, daclizumab, rituximab, ocrelizumab and ofatumumab.

MS requires lifelong DMTs, and all of the currently available first-line DMTs are parenteral formulations only. As the advent of new oral drugs will lead to increased patient compliance and contribute to longer sustain symptom-free periods and less marked disability.

Recent approval of fingolimod, teriflunomide and dimethyl fumarate, as the oral drugs to treat MS has marked a new frontier in the treatment of MS. Their entry onto the market will provide additional treatment options.

Laquinimod: Laquinimod is an immunomodulator has been shown to promote anti-inflammatory cytokine profiles in human peripheral blood mononuclear cells. In EAE models, laquinimod had effectively reduced inflammation, demyelination, and axonal damage (Bruck and Wegner, 2011).

Laquinimod has been evaluated in phase III trials, in patients with RRMS who were randomised to receive laquinimod or placebo. Laquinimod treatment resulted in reduction in ARR vs. placebo and decrease in the risk for disability progression, as measured by EDSS. Treatment with laquinimod was also associated with reduction in progression of brain atrophy vs. placebo (Comi, 2013).

In the second phase III study, laquinimod was compared with placebo in patients with RRMS. Laquinimod was associated with a statistically significant reduction of ARR , risk of disability progression and of brain volume loss compared with placebo (Consortium of Multiple Sclerosis Centers, 2011)..

Alemtuzumab: Alemtuzumab is a humanised monoclonal antibody against CD52, a glycoprotein antigen found on the surface of mature lymphocytes and monocytes. The exact biological function of CD52 remains unclear but some evidence suggests that it may be involved in T-cell migration (Watanabe et al., 2006). Alemtuzumab has also been shown to induce production of neurotrophic factors in reconstituted autoreactive T cells (Jones et al., 2010).

Efficacy of alemtuzumab for the treatment of MS has been assessed through a number of clinical trials. In a Phase II study (CAMMS223), Treatment with alemtuzumab was associated with a significant reduction of annualized relapse rate compared to IFN- $\beta$ -1a as well as significantly decreased T2-weighted lesion burden than IFN- $\beta$ -1a. Patients who were treated with alemtuzumab experienced a significantly lower rate of sustained disability accumulation versus IFN- $\beta$ -1a as evidenced by improvements of the EDSS score (Coles, 2008).

Two Phase III studies [CARE-MS I and CARE-MS II (Cohen et al., 2012; Coles et al., 2012)] evaluated the safety and efficacy of alemtuzumab compared with INF- $\beta$  in patients with RRMS. In both studies, a significant reduction in relapse rate compared with interferon-beta 1a was observed. In one of the trials, a significant reduction in disease progression compared with interferon-beta 1a was also seen.

Daclizumab: Daclizumab is a humanised monoclonal antibody directed against the high-affinity IL-2 receptor. This receptor is present on activated, but not resting, T cells. Binding of IL-2 to this receptor is necessary for clonal expansion and continued viability of activated T cells (Vincenti et al., 1998).

Daclizumab was evaluated for the treatment of RRMS in the phase II CHOICE trial. It was a placebo-controlled study in patients with active disease despite IFN- $\beta$  treatment. Patients were randomised to receive two different subcutaneous doses of daclizumab or placebo as an adjunct to their current IFN- $\beta$  therapy. The mean number of new or enlarged gadolinium-enhancing lesions was 4.75 in the IFN- $\beta$ -

placebo group vs. 1.32 for patients who received IFN- $\beta$  with high-dose daclizumab and 3.58 for those treated with IFN- $\beta$  with low-dose daclizumab) (Wynn et al., 2010).

SELECT is a phase II clinical trial that evaluated two doses of daclizumab in patients with RRMS (Business Wire., 2011). At 1 year, daclizumab was associated with significant reductions in ARR for both dose groups,

Daclizumab is also being compared with i.m. IFN- $\beta$ -1a in a phase III study in patients with RRMS (ClinicalTrials.gov., 2011).

Rituximab: Rituximab is a chimeric monoclonal antibody that depletes CD20-positive B cells through cell-mediated and complement-dependent cytotoxic effects and promotion of apoptosis. A phase II clinical trial assessed efficacy of rituximab in patient with RRMS, rituximab treatment resulted in significantly decreased numbers of gadolinium-enhancing lesions vs. placebo as well as a significantly decreased risk for relapse (Hauser et al., 2008). The results of a phase II/III placebo-controlled trial in PPMS revealed no significant difference in the time to confirmed disease progression between the placebo and rituximab groups (Hawker et al., 2009).

Ocrelizumab: Ocrelizumab is a humanised anti-CD20 monoclonal antibody that results in B cell depletion. It has been evaluated in patients with RRMS who were randomised to treatment with i.v. ocrelizumab and i.m. IFN- $\beta$ -1a or placebo. The mean number of gadolinium-enhancing lesions was reduced in the treated group compared to placebo (Kappos et al., 2011).

Ocrelizumab is also being evaluated in phase III, placebo-controlled trial in patients with PPMS (Montalban et al., 2011). The primary outcome measure of this trial is time to onset of sustained disability progression (Hauser et al., 2008). Two large global studies will compare ocrelizumab with IFN- $\beta$ -1a subcutaneous (OPERA I and II) in patients with RRMS (Clinical Trials.gov., 2012).

Ofatumumab: Ofatumumab is a third anti-CD20 antibody being developed for the treatment of MS. A phase II safety and pharmacokinetics study in with RRMS indicated no dose-limiting toxicities and no unexpected safety findings. Active treatment also resulted in significant reductions in the number of gadolinium-enhancing T1 lesions and new/enlarging T2 lesions in patients treated with ofatumumab vs. placebo (Genmab., 2011).

#### 1.1.10.4 Symptomatic Treatment

Symptomatic treatment is an essential component of the management of MS. The aims of symptomatic treatment are ; elimination or reduction of symptoms impairing the functional abilities and QoL of the affected patients and avoiding development of a secondary physical impairment due to an existing disease effects. Many therapeutic techniques as well as different pharmacological agents have tried for the treatment of MS symptoms (Table1.2).

**Table1.2 Symptomatic treatments for multiple sclerosis.** Source: (Compston and Coles, 2008)

Symptoms	Signs	Treatment		
		Established efficacy	Equivocal efficacy	Speculative
Cognitive impairment	Deficits in attention, reasoning, and executive function (early); dementia (late)			Cognitive training
Hemisensory and motor	Upper motor neuron signs			
Affective (mainly depression)		Antidepressant drugs		
Epilepsy (rare)		Anticonvulsants		
Focal cortical deficits (rare)				
Unilateral painful loss of	Scotoma, reduced visual acuity,	Low vision aids		

vision	colour vision, and relative afferent pupillary defect			
Tremor	Postural and action tremor, dysarthria			Carbamazepine, B.blockers, clonazepam, thalamomectomy, and thalamic stimulation
Clumsiness and poor balance	Limb incoordination and gait ataxia			
Diplopia, oscillopsia	Nystagmus, internuclear ophthalmoplegias			Baclofen, gabapentin
Vertigo			Prochlorperazine, cinnarazine	
Impaired swallowing	Dysarthria	Anticholinergic drugs		Speech therapy
Impaired speech	Pseudobulbar palsy	Tricyclic antidepressants		Speech therapy
Paroxysmal symptoms		Carbamazepine, gabapentin		
Weakness	Upper motor neuron signs			
Stiffness and painful spasms	Spasticity	Tizanidine, baclofen, dantrolene, benzodiazepine, intrathecal baclofen	Botulinum toxin, corticosteroids	Cannabinoids
Bladder dysfunction		Anticholinergic drugs and/or intermittent self-catheterisation,	Decompressing, intravesical botulinum toxin	Abdominal vibration, cranberry juice
Erectile impotence		Sildenafil		
Constipation		Bulk laxatives, enema		
Pain		Carbamazepine, gabapentin	Tricyclic antidepressant drugs, transcutaneous electrical nerve stimulation	
Fatigue		Amantadine	Modafinil	Pemoline, fluoxetine
Temperature sensitivity and exercise intolerance				Cooling suit, 4-aminopyridine

#### 1.1.10.5 Neuroprotective agents

There is increasing evidence that degenerative mechanisms are present in all the progressive forms of MS. Therefore restorative therapies that improve function of damaged neural pathways, as well as neuroprotective and repair strategies, will be necessary.

There are several agents which may show promise as potential neuroprotective therapies that could prevent axonal and neuronal damage either directly or indirectly after CNS insults. These include:

Disease modifying therapies: Results from several studies have suggested improvement disability outcomes in DMTs treated patients but the actual benefit of long term treatment in the later stages of the disease is unclear (Van der Walt et al., 2010). Importantly, the available DMTs are only partially effective in preventing the onset of permanent disability in MS patient (Trojano et al., 2007). The current existing DMTs predominantly target the recruitment of systemic immune responses and, as such, they would not be expected to modulate significantly the pathogenesis of axonal degeneration once it is established.

Growth Factors:

- Insulin-like growth factor-1 (IGF-1): IGF-1 promotes oligodendrocytes growth and maturation (McMorris and McKinnon, 1996) and also enhances neuronal development (Ozdinler and Macklis, 2006). The results of studies of IGF-1 in EAE models are conflicting, initial studies showed an improvement in disability in acute and chronic demyelinating EAE (Li et al., 1998; Yao et al., 1996). Subsequent studies showed a transient effect only (Cannella et al., 2000), or failed to show a sustained benefit of IGF-1 in EAE (Genoud et al., 2005). In a pilot study IGF-1 had administered to few patients with



SPMS showed no improvement in the primary MRI endpoints, including new enhancing lesions, WM lesion load (Frank et al., 2002).

- Erythropoietin: Erythropoietin is a haematopoietic growth factor. Its anti-inflammatory and neuroprotection effects has been established in experiments in different models of EAE (Agnello et al., 2002). Both Li et al and Diem et al have found that Erythropoietin decrease in axonal loss in EAE compared to controls (Diem et al., 2005; Li et al., 1998). In an open-label pilot study Erythropoietin has been tested in humans suffering from chronic progressive MS. Clinical and neurophysiological improvement of motor function and cognitive performance was reported (Ehrenreich et al., 2007)
- The neuropoietic cytokines (leukaemia-inhibitory factor (LIF) and ciliary neurotrophic factor (CNTF): There is a large amount of evidence to suggest that LIF and CNTF enhance neuronal survival in the context of axonal injury (Hagg et al., 1993). It has been found that survival after axotomy (transaction of the axon from the nerve cell body) can be improved in new born rats by the administration of either LIF (Hughes et al., 1993) or CNTF (Sendtner et al., 1992). Recent work highlights the fact that CNTF exerts more robust effects on neuronal survival and growth when applied in combination with its soluble form of CNTF-receptor-  $\alpha$  (Ozog et al., 2008).

Sodium Channel Blockers: Evidence from EAE studies has shown a beneficial effect of sodium-blocking agents, such as flecainide and lamotrigine to improve axonal survival and decrease disability (Bechtold et al., 2004; Bechtold et al., 2006). In contrast, in a phase II placebo-controlled clinical trial Kapoor et al have not found neuroprotective effects of treatment with lamotrigine in SPMS (Kapoor et al., 2008).

Calcium Channel Blockers: A study suggested that calcium channel blockers prevent axonal loss and disability in treated EAE animals (Brand-Schieber and

Werner, 2004). Another study has suggested a possible neuroprotective effect of some of the calcium channel blockers such as nimodipine, nifedipine and ryanodine (Ouardouz et al., 2009).

Mesenchymal Stem Cells: Autologous bone marrow (ABM) derived mesenchymal stem cell (MSC) can promote neuroprotection by inhibiting gliosis, apoptosis, and stimulate local progenitor cells (Yang et al., 2009). Evidence shows a specific immunomodulatory effect of MSCs through inhibition of T and B cells and maturation of antigen presenting cells (Uccelli et al., 2006). On the other hand several EAE experiments have shown that treatment with ABM derived MSC significantly improved clinical outcomes (Bai et al., 2009; Gordon et al., 2008; Kassis et al., 2008; Zappia et al., 2005; Zhang et al., 2005).

Glutamate Antagonists: Treatment with glutamate antagonist in EAE result in substantial amelioration of disease, increased oligodendrocyte survival and reduced neurofilament H, an indicator of axonal damage (Pitt et al., 2000). Memantine, a N-methyl-D-aspartate antagonist has shown amelioration of disability in EAE (Wallstrom et al., 1996). Kalkers et al. has assessed the effect of riluzole in a small cohort of PPMS patients in an open-label study. The study revealed a nonsignificant reduction in the rate of cervical cord atrophy and decrease in the development of T1 hypointense lesions (Kalkers et al., 2002).

HMG-CoA Reductase Inhibitors (Statins): Evidence of neuroprotection due to statin therapy in preclinical studies has been demonstrated in several studies through a possible reduction in axonal loss (Neuhaus and Hartung, 2007; Paintlia et al., 2009; Sena et al., 2003; Youssef et al., 2002). Available clinical data regarding statins in the treatment of MS are not entirely consistent. Most of the studies have showed no benefit (Rudick et al., 2009; Sorensen et al., 2011; Wang et al., 2011). In contrast, a study enrolled 30 patients with active RRMS (Vollmer et al., 2004) has showed a

significant decrease in the number of gadolinium-enhancing lesions in brain MRI scans compared with pre-treatment brain MRI scans.

Cannabinoids: Cannabis is used by MS patients for relief from a variety of symptoms (Clark et al., 2004). In vitro studies have suggested effect of cannabinoids on several potential mechanisms of axonal injury, including glutamate release (Fujiwara and Egashira, 2004), oxidative free radicals as well as damaging calcium flux (Kreitzer and Regehr, 2001). Which, in excess, can cause neuronal death in neuroinflammatory disease (Kapoor et al., 2003; Pitt et al., 2000). Furthermore, exogenous agonists of the cannabinoid CB1-receptor have possible neuroprotective effects in EAE animal models (Pryce et al., 2003). Subsequent clinical studies on cannabinoids for symptomatic treatment of MS (Rog et al., 2005; Zajicek et al., 2003; Zajicek et al., 2012) , and understanding of the biology of cannabis shows that cannabis signals to an endogenous cannabinoid system via cannabinoid receptors which can regulate neurotransmission and cell death pathways (Howlett et al., 2002). Despite these promising results, neuroprotective effects in MS by cannabinoids and the modulation of the endocannabinoid system must still be established.

Modafinil: Modafinil is a wakefulness-promoting agent. Besides the already FDA approved uses, modafinil also has potential non-approved clinical uses which some of them increasingly believed to be neuroprotection. Modafinil prevents glutamate toxicity in cultured cortical cells (Antonelli et al., 1998). Another study conducted on rat had suggested that modafinil can decrease toxic aspartate and glutamate levels after striatal ischemic injury caused by endothelin-1 (Ueki et al., 1993a). Furthermore, it was found that modafinil can prevents development of lesions in the hippocampus induced by the neurotoxic nerve gas soman (Lallement et al., 1997). Clinically, in a recent retrospective study, we suggest that modafinil significantly reduces the disease severity in MS measured by EDSS score (Bibani et al., 2012).

The neuroprotective potential of modafinil has been tested in other neurodegenerative diseases, in particular Parkinson's disease (PD). The result of some studies found that modafinil could prevent degeneration of the nigrostriatal pathway in 1-methyl-4-phenyl-1,2,3,6-tetrahydropyridine (MPTP) induced PD models and mechanical injury of the nigrostriatal pathway (Fuxe et al., 1992; Jenner et al., 2000; van Vliet et al., 2006; Xiao et al., 2004). Modafinil will be discussed further in this thesis.

#### **1.1.11 Prognosis and complications of Multiple Sclerosis**

The clinical subtype of the disease; the individual's sex, race, age, and initial symptoms; and the degree of disability the person experiences were shown to have contribution with the expected future course of MS. Individuals with progressive subtypes of MS, particularly the primary progressive subtype, have a more rapid decline in physical and mental functions. Older individuals when diagnosed are more likely to experience a chronic progressive course, with more rapid progression of disability. Females generally have a better prognosis than males. Initial MS symptoms of sensory problems or visual symptoms, are predictors for a relatively good prognosis, whereas motor problems are markers for a relatively poor prognosis. Better outcomes are also associated with the presence of only a single symptom at onset.

The degree of disability varies among individuals with MS. In general, one of three individuals will still be able to work after 15–20 years. 15% of people diagnosed with MS never have a second relapse, and these people have minimal or no disability after ten years (Pittock et al., 2004).

The life expectancy of people with MS is 5 to 10 years lower than that of unaffected people and two-thirds of the deaths in people with MS are directly related to the consequences of the disease (Compston and Coles, 2008). Despite improvement in management of MS, along with some successful treatment infection such as

pneumonia and urinary tract infection are common complications of MS. The risk of suicide is common in MS patients. Young patients are the most likely victim (Sadovnick et al., 1992).

Interestingly, it has been found that deaths from malignancy are less common than in age-matched controls (Sadovnick et al., 1991).

Higher EDSS scores are associated with increased mortality. Median time from disease onset to reaching a disability level when one needs a walking-aid is about 20 years (Confavreux et al., 2003; Myhr et al., 2001; Phadke, 1987). MS has heavy economic and personal burden. The costs are highly correlated with disease severity (Kobelt et al., 2006; Parkin et al., 2000).

## **1.2 EXPERIMENTAL AUTOIMMUNE ENCEPHALOMYELITIS AND MULTIPLE SCLEROSIS**

In the second decade of 20<sup>th</sup> century, Experimental autoimmune encephalomyelitis (EAE) was first described by Koritschoner and Schweinburg (Koritschoner and Schweinburg, 1925). They induced spinal cord inflammation in rabbits by inoculation with human spinal cord. Subsequently, researchers have attempted to reproduce the encephalitic complications associated with rabies vaccination by repetitive immunisation of rhesus monkeys with CNS tissue (Rivers et al., 1933). Moreover, studies have showed that EAE can be elicited in many different species, including rodents and primates, and from these studies it became clear that EAE can reproduce many of the clinical, neuropathological and immunological aspects of the neurodegenerative disease including MS (Hohlfeld and Wekerle, 2001). At the present time, EAE studies have provided an insight into general neuroscience and immunology concepts, and developing general therapeutic strategies.

### **1.2.1 EAE induction**

EAE can be induced in susceptible strains of different species by sensitisation with CNS myelin antigens (Active EAE) (Williams et al., 1994), or by the adoptive transfer of CNS myelin antigen-specific CD4<sup>+</sup> T cells into naive syngeneic recipients (Passive EAE) (Pender, 1995; Pettinelli and McFarlin, 1981).

### **1.2.2 Pathogenesis of EAE**

There is substantial evidence that the initiating effector lymphocyte in EAE pathogenesis is the autoreactive CNS specific CD4<sup>+</sup> T cell; however, it has been found that myelin specific CD8<sup>+</sup> T cells also play a role in EAE pathogenesis [reviewed in (Goverman et al., 2005)].

Besides T cells the role of B cells in EAE pathogenesis has been demonstrated (Wolf et al., 1996). However, the role of B cell and its contributions to EAE pathogenesis appears to be contradictory and may reflect the involvement of multiple roles for B cells or different B cell subsets during disease pathogenesis (Bouaziz et al., 2008).

### **1.2.3 Clinical scores of EAE**

In the classic EAE model, animals develop an ascending flaccid paralysis, which – depending on disease severity – The clinical scoring scale is as follows; 0—healthy, 1—flaccid tail, 2—impaired righting reflex and/or impaired gait, 3—partial hind-leg paralysis, 4—total hind-leg paralysis, 5—any sign of front-leg paralysis, and 6—moribund/ dead (O'Brien et al., 2010).

### **1.2.4 EAE and multiple sclerosis**

EAE is primarily used as an animal model of autoimmune inflammatory diseases of the CNS. It has become a well characterised model for organ-specific autoimmune disease in general. EAE contributed enormously to our understanding of autoimmunity, neuroinflammation, cytokine biology and immunogenetics, and the development of MS therapeutics.

Mice and rats have been used commonly for EAE. In addition certain monkey species like marmosets are used for specific questions that cannot be easily assessed in rodents (t Hart et al., 2011). Most studies are presently done using C57BL/6 mice, where disease is induced by immunisation with myelin oligodendrocyte glycoprotein (MOG) peptide, representing residues 35–55, emulsified in Freund's adjuvant that is supplemented with *Mycobacterium tuberculosis* extract. This protocol is used because it works reproducibly and because it allows one to take advantage of the wealth of genetic resources on the C57BL/6 background. There are some limitations of this protocol when translated to

the MS: In most cases, the C57BL/6 model of EAE is monophasic, without relapses; the T cell component is predominantly CD4<sup>+</sup>; and spinal cord is affected out of proportion to brain.

### **1.2.5 EAE and multiple sclerosis treatments**

EAE has contributed to the development, validation, and testing of MS drugs. One major MS treatment (Natalizumab) came directly, in a mechanism-based fashion, from EAE research (Polman et al., 2006). EAE has also played a successful role in assurance of the currently licensed and used DMT: IFN-beta (Abreu, 1982) GA (Johnson et al., 1995; Teitelbaum et al., 1971) and the anti-VLA-4 antibody (Polman et al., 2006). A substantial number of other studies have shown treatment success with concordant results in EAE and MS, using a variety of compounds. Some of these agents, like azathioprine, mitoxantrone and fingolimod are licenced or well-established therapies for specific groups of patients with MS. Others, like laquinimod have reached late phase clinical trials [reviewed in (Constantinescu et al., 2011a)].

However, numerous other therapeutics that showed promise in EAE were found to be ineffective or detrimental in MS (Denic et al., 2011).

### **1.2.6 Major differences between EAE and multiple sclerosis**

Beside all promising achievement from EAE studies in relation to MS, there are differences in aetiopathogenesis, immunohistopathology, and genetic components between EAE and MS. To reduce the gap between EAE and MS creating new and refined EAE models in humanized mice or perhaps by switching to species more closely related to humans, such as the common marmoset (*Callithrix jacchus*). The MS-like disease phenotype of marmoset EAE is particularly useful to investigate treatment approaches in relapsing-remitting and chronic forms of MS (t Hart et al., 2011).



## **1.3 MODAFINIL (PROVIGIL)**

### **1.3.1 Introduction**

In the late 1970s scientists working with the French pharmaceutical company Lafon have generated a novel wake-promoting agent known as Adrafinil. In the early 1990s the primary metabolite of Adrafinil, Modafinil, was derived which had similar activity. Modafinil has been prescribed in France since 1994 under the name Modiodal, and in the US since 1998 as Provigil. Its approval for use in the UK was in December 2002. In 1998 modafinil was approved by the United State food and drug administration (USFDA) for excessive daytime sleepiness (EDS) associated with narcolepsy. Almost a decade later evidence emerged showing its effectiveness in treating several sleep disorders (Ballon and Feife, 2006). Modafinil was approved by USFDA in 2004 for the treatment of obstructive sleep apnoea/hypopnoea (OSA) syndrome, and shift work sleep disorder (SWSD) (Minzenberg and Carter, 2007).

Modafinil that is chemically and pharmacologically different from other central nervous system (CNS) stimulants (Saper and Scammell, 2004) has a large potential for many uses in psychiatry, neurology and general medicine. Because of its ability to improve several clinical symptoms in different diseases modafinil seems to be one of the important drugs. The pharmacologic effects of modafinil are complex and it is thought to alter various neurotransmitters in the brain (Minzenberg and Carter, 2007). A clear mode of action of modafinil has not been established so far but interaction of modafinil with dopaminergic, noradrenergic, glutamatergic, gamma-aminobutyric acid (GABA)ergic, serotonergic, orexinergic, and histaminergic pathways have been suggested in several animal studies (Ballon and Feife, 2006; Ferraro et al., 1999; Ferraro et al., 1998; Ferraro et al., 2002; Madras et al., 2006; Minzenberg and Carter, 2007).

Modafinil has been investigated in healthy volunteers, and in individuals with clinical disorders. Its beneficial effect has been shown in many clinical disorders associated

with excessive sleepiness, fatigue, impaired cognition and other symptoms such as myotonic dystrophy (MacDonald et al., 2002), attention deficit hyperactivity disorder (ADHD) in children and adolescents (Lindsay et al., 2006), depression (DeBattista et al., 2004), Parkinson's disease (PD), multiple sclerosis (MS) (Bibani et al., 2012; Littleton et al., 2010; Rammohan et al., 2002), and hastening recovery from general anaesthesia (Larijani et al., 2004). In sleep-deprived healthy volunteers, modafinil improves mood, fatigue, sleepiness and cognition (Wesensten et al., 2005). Modafinil improves the ability of the on call physicians to attend lectures after a full night shift in emergency departments (Gill et al., 2006).

The potential interactions of modafinil with a variety of drugs through induction and inhibition several cytochrome P450 isoenzymes has been reported (Robertson et al., 2000). Reduction of the modafinil dose in old age groups and in patients with hepatic and renal impairment is mandatory. Insomnia, headache, nausea, nervousness and hypertension are commonly reported adverse effects of modafinil (Robertson and Hellriegel, 2003). Other less common side effects of modafinil are decrease of appetite, weight loss and dermatological problems. Children and adolescents have greater risk to get these side effects. Modafinil may theoretically have some abuse/addictive potential. The results seen in two trials on cocaine addiction treated with modafinil were inconclusive (Dackis et al., 2005; Umanoff, 2005).

### **1.3.2 Pharmacodynamic Properties of Modafinil**

Modafinil is (2-[(diphenylmethyl) sulfinyl] acetamide. The molecular formula is  $C_{15}H_{15}NO_2S$  and the molecular weight is 273.35. The chemical structure is shown in (Figure 1.6).

Modafinil has two enantiomers (R-modafinil and S-modafinil). The R-modafinil also known as armodafinil has longer half-life than S-modafinil while the S-modafinil has

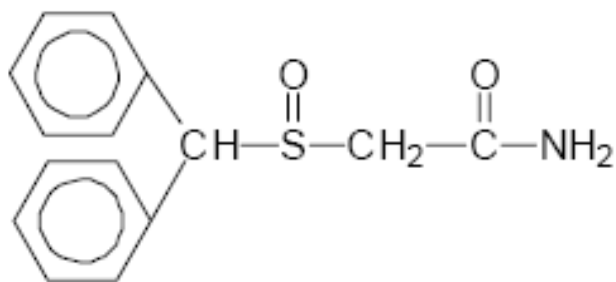

**Figure 1.6 Chemical structure of modafinil.**

a faster rate of clearance. The wake-promoting activity is likely due primarily to the R-modafinil (Robertson and Hellriegel, 2003). Modafinil is used in a once-daily dosing. It is readily absorbed from gastrointestinal tract and maximum plasma concentrations occur at 2–4 hours (Robertson and Hellriegel, 2003). Metabolism occurs primarily through the liver, with renal elimination of metabolites (Robertson and Hellriegel, 2003). Less than 10% of the administered dose is excreted in urine as unchanged drug (Robertson and Hellriegel, 2003; Wong et al., 1999). Modafinil induces the cytochrome P450 enzymes CYP1A2, and CYP3A4 and has potential to inhibit CYP2C19 (Robertson et al., 2000), thus it may prolong elimination and increase circulating levels of drugs that are primarily metabolized via this enzyme (e.g., diazepam, phenytoin, and propranolol). Modafinil suppressed CYP2C9 activity in cultures of human hepatocytes, suggesting a potential for drug interactions between modafinil and enzyme substrates such as warfarin and phenytoin (Robertson Jr et al., 2002). Modafinil also enhances the effects of antidepressants (Menza et al. 2000, Ninan et al. 2004).

### **1.3.3 Clinical Efficacy and Tolerability of Modafinil**

The efficacy and tolerability of modafinil were recognised in several studies with different designs. These studies have been conducted in patients with OSA (Black and Hirshkowitz, 2005; Pack et al., 2001), SWSD (Czeisler et al., 2005), and

narcolepsy (Mittler et al., 2000). However, a significant greater frequency of adverse effects has been reported with modafinil in placebo-controlled clinical trials, and these were more frequent with fixed dose studies than the in flexible dose study (Swanson et al., 2006). Increase in both systolic and diastolic blood pressure (BP) with modafinil has been reported (Muller et al., 2004; Turner et al., 2003). In contrast, several studies have reported no significant changes in BP (systolic and diastolic), pulse rate and/or electrocardiography (ECG) (Biederman et al., 2005; Black and Hirshkowitz, 2005; Broughton et al., 1997; Greenhill et al., 2006; Saletu et al., 1989) . A significantly higher rating for somatic anxiety and several physical symptoms such as tremor, palpitations, dizziness, muscular tension, physical tiredness and irritability have been reported with modafinil compared with placebo (Randall et al., 2003). Decreased appetite and weight loss with modafinil was reported in studies of ADHD (Biederman et al., 2005; Greenhill et al., 2006). Different types of skin lesions related to modafinil taking have been reported inform of maculopapular/morbiliform rash and a case of possible erythema multiforme/Stevens-Johnson Syndrome (Biederman et al., 2005). Two patients with major depressive disorder developed suicidal ideation in the second week of a trial of combined modafinil and serotonin reuptake inhibitors (SRI) therapy (Dunlop et al., 2007). Psychosis has been reported with modafinil in schizophrenia, post-polio fatigue patients and in SWSD patient without any history of psychiatric disorder (Mariani and Hart, 2005; Spence et al., 2005; Vasconcelos et al., 2007). Withdrawal symptoms of modafinil have not been observed in subjects with ADHD (Greenhill et al., 2006). There is no conclusive evidence for abuse potential of modafinil so far, as the psychomotor effects of modafinil do not appear to be mediated via a catecholamine mechanism (Ferraro et al., 1996), which might account for modafinil's reduced side-effect profile and low abuse potential (Deroche-Gamonet et al., 2002). A single fatal case of multi-organ hypersensitivity reaction has been described (Sabatine et al., 2007).

### **1.3.4 Mechanism of Action of Modafinil**

Modafinil: has been named “a drug in search of a mechanism” (Saper and Scammell, 2004). Despite several years of studies a well-defined biochemical mechanism of action of modafinil has not yet been elucidated. The pharmacologic effects of modafinil are complex and it is thought to alter various neurotransmitters in the brain (Minzenberg and Carter, 2007). Briefly, in animal studies, modafinil has been shown to interact with dopaminergic, noradrenergic, glutamatergic, GABAergic, serotonergic, orexinergic, and histaminergic pathways (Ballon and Feife, 2006; Madras et al., 2006; Minzenberg and Carter, 2007). It has been demonstrated that modafinil activates the hippocampus, which receives afferent innervation from the sleep-wake centre of the hypothalamus (Becker et al., 2004; Kim et al., 2007).

#### **1.3.4.1 Effects of Modafinil on the Dopaminergic Pathways**

The evidence regarding the interaction of dopaminergic pathway in modafinil's mode of action has changed over time. The initial animal studies showed modafinil had only a weak affinity for dopamine receptors (Mignot et al., 1994), and had not stimulated release of dopamine in the mouse caudate nucleus (De Sereville et al., 1994). Furthermore, it has no effect on the firing rate of the dopaminergic neurons in the rat midbrain (Akaoka et al., 1991). In other studies it was also found that various dopamine D1 and D2 receptor antagonists and inhibition of dopamine synthesis does not affect on the modafinil-induced hyperactivity in mice (Duteil et al., 1990; Simon et al., 1995), importantly, a slight reduction of the arousal with modafinil has been reported in cats (Lin et al., 1992). In contrast subsequent animal studies showed that modafinil administration in different doses and routes leads to increased extracellular levels of dopamine in the prefrontal cortex (Hilaire et al., 2001), caudate nucleus (Wisor et al., 2001), nucleus accumbens (Murillo-Rodriguez et al., 2007), and striatal slices preloaded with [<sup>3</sup>H]dopamine (Dopheide et al., 2007).

Also it has been found that modafinil inhibits the dopaminergic neurons in the ventral tegmental area and the substantia nigra (Korotkova et al., 2006). Evidence from preclinical studies suggests that Modafinil increases dopamine in brain by targeting the dopamine transporters (DAT) (Greenhill, 2006). On the other hand the role of dopamine receptors (D1 and D2) in the mode of action of modafinil have been evaluated and it was found that D1 and D2 receptors are involved in alerting effects of modafinil (Qu et al., 2008).

By using recent MRI techniques (positron emission tomography (PET)) the idea about interaction of dopamine in the mode of action of modafinil was further expanded. Madras et al (2006) used this technique and documented the significant occupancy of striatal DAT by modafinil in monkeys and in vitro modafinil inhibits DATs . Furthermore, in a supporting study it was found that mice lacking DAT do not respond to the wake-promoting effects of modafinil (Wisor et al., 2001). Findings from a human study documented the crucial role of dopamine in the wake-promoting effects of modafinil, and the blockage of DATs and increased dopamine in the human brain (including the nucleus accumbens) (Volkow et al., 2009).

#### **1.3.4.2 Effects of Modafinil on Noradrenergic Pathways**

There is considerable pharmacological evidence that modafinil, acts through adrenergic mechanisms to promote waking. Animal studies found that modafinil increases levels of noradrenaline in the rat prefrontal cortex and medial hypothalamus (de Saint Hilaire et al., 2001). In rat brain slices, modafinil potentiates noradrenergic inhibition of the sleep active neurons of the ventrolateral preoptic area of the hypothalamus (Gallopín et al., 2004). Various  $\alpha$ -adrenoceptor antagonists attenuate the modafinil-induced arousal in cats (Lin et al., 1992), and locomotor activity in mice (Stone et al., 2002) and monkeys (Duteil et al., 1990). Evidence has strongly suggested that modafinil promotes waking by activating  $\alpha$ 1-adrenergic receptors. Response to modafinil was significantly reduced in genetically  $\alpha$ 1-

adrenoceptor-deficient mice (Stone et al., 2002). Furthermore, modafinil occupies noradrenaline transporter (NAT) sites in the thalamus of rhesus monkeys in vivo and blocks noradrenaline transport via NAT in vitro (Madras et al., 2006). On the other hand, it has been found that Modafinil does not bind to adrenergic receptors at physiological doses (Mignot et al., 1994), and it does not affect the firing rate of the rat pontine noradrenergic neurons (Akaoka et al., 1991) and it does little to reduce cataplexy that normally responds to  $\alpha$ 1-receptor agonists or to agents that block the reuptake of noradrenaline by NAT (Mignot et al., 1993; Nishino et al., 1993).

#### **1.3.4.3 Effects of Modafinil on Glutamate**

Ferraro et al in series of studies found that modafinil increases levels of the glutamate in the thalamus and hippocampus (Ferraro et al., 1997), striatum (Ferraro et al., 1998) and medial pre-optic area and the posterior hypothalamus (Ferraro et al., 1999) of the rat brain.

#### **1.3.4.4 Effect of Modafinil on gama amino butyric acid (GABA)**

Animal studies have reported the effect of modafinil in reducing GABA levels in the cortex (Tanganelli et al., 1994), medial pre-optic area and posterior hypothalamus (Ferraro et al., 1999), hippocampus (Ferraro et al., 1997), nucleus accumbens, striatum, globus pallidus and substantia nigra (Ferraro et al., 1998). This might lead to the conclusion that via GABA reductions, modafinil is able to improve motor activity and cortical functions (Della Marca et al., 2004).

#### **1.3.4.5 Effect of Modafinil on serotonin**

There is an inverse effect of modafinil on the level of serotonin and GABA in different brain areas. Studies have found that modafinil decreases levels of GABA, but increases levels of serotonin (Ferraro et al., 2000; Ferraro et al., 2002). Also, it has found that SRIs and serotonin selective neurotoxins abolish the effect of modafinil on GABA release (Tanganelli et al., 1992; Tanganelli et al., 1995). SRIs

enhance the effect of modafinil on serotonin levels (Ferraro et al., 2005; Ferraro et al., 2002).

#### **1.3.4.6 Effects of Modafinil on Histaminergic Pathways**

Ishizuka et al (2008) found that modafinil increases histamine levels in the anterior hypothalamus in rats . They also found that enhancement of the locomotor activity in treated rats with modafinil is reversible with depletion of neuronal histamine.

#### **1.3.4.7 Effects of Modafinil on Orexinergic Pathways**

The interaction of modafinil with orexin neurons in the brain is complicated and not clear yet. Although modafinil activates the orexin neurons (Scammell et al., 2000), it is also useful for narcolepsy deficient in orexin neurons (Nishino, 2003). It has also been found that modafinil is more effective in producing wakefulness in orexin knockout mice than in wild-type litter mates (Willie et al., 2005).

### **1.3.5 Approved Indications of Modafinil**

The use of modafinil has been approved for ameliorating the excessive sleepiness associated with narcolepsy, SWSD and residual sleepiness in OSA.

#### **1.3.5.1 Narcolepsy**

The main symptoms of narcolepsy are EDS, cataplexy (an abrupt loss of muscle tone triggered by emotion), hypnagogic hallucinations and sleep paralysis. Four randomised, double-blind, placebo-controlled trials have assessed the usefulness of modafinil in treatment of EDS in narcolepsy (Billiard et al., 1994; Broughton et al., 1997; Fry, 1998; US Modafinil in Narcolepsy Multicenter Study, 1998). Improvement of EDS by the objective measures in all four studies have demonstrated and improvement by the subjective Epworth Sleepiness Scale (ESS) was also seen except the Billiard et al study.



### **1.3.5.2 Obstructive Sleep Apnoea (OSA)**

EDS is one of the main symptoms of OSA and continuous positive airway pressure (CPAP) is the gold-standard treatment for OSA. Modafinil is approved by the FDA for treating residual sleepiness despite optimal treatment of OSA (in November 2010 The Agency's Committee for Medicinal Products for Human Use (CHMP) recommended that this indication should remove from the product information). Several studies have carried out for evaluation the role of Modafinil in OSA. The largest of these studies was a double-blind, randomised, placebo-controlled study (Pack et al., 2001) The primary efficacy measures were ESS, multiple sleep latency test (MSLT) results, and CPAP use. The positive effects of modafinil have demonstrated in both the ESS and MSLT results, while there was no difference noted in CPAP use between groups. In another relatively similar size study Black and Hirshkowitz, have confirmed the effectiveness of modafinil in the clinical situation which showed that the efficacy of modafinil, as measured subjectively by the ESS and objectively by the maintenance of wakefulness test (MWT), does not change over an extended period of the study which was 12 weeks (Black and Hirshkowitz, 2005). Although reduction in the CPAP usage was not decreased in both mentioned studies this was noted in the smaller randomised study of modafinil (Kingshott et al., 2001) and in an open-label extension trial (Schwartz et al., 2003). Moreover, modafinil improved symptoms of depression, anxiety, and irritability in patients with OSA (Kumar, 2008).

### **1.3.5.3 Shift-Work Sleep Disorder (SWSD)**

Three randomised, double-blind, placebo-controlled, parallel group, multicentre trials have evaluated the usefulness of modafinil in SWSD with different measures of efficacy. In the first trial (Czeisler et al., 2005), The modafinil group had a statistically significant increase in mean sleep latency compared with the placebo group, Patients taking modafinil also had a significant improvement in performance on a

vigilance test. In the second trial (Erman and Rosenberg, 2007), a statistically significant greater increase in the mean Functional Outcomes of Sleep Questionnaire score in patients received modafinil compared with placebo was seen, also a significant improvements in the activity and in the vigilance and productivity domain scores with modafinil were reported. Furthermore Modafinil significantly improved the mental and emotional scores compared with placebo. In the third study (Walsh et al., 2004) a significant improvement on vigilance testing and the Maintenance of Wakefulness Test (MWT) have been reported.

### **1.3.6 Investigational Uses of Modafinil**

#### **1.3.6.1 Neurological Disorders**

##### **1.3.6.1.1 Parkinson's disease**

EDS is one of the main symptom of PD (Ondo et al., 2005). Significant improvement in ESS scores were seen in two small, randomised, double-blind, placebo-controlled studies (Adler et al., 2003; Happe et al., 2001). In contrast this achievement was not found in another study with similar design (Ondo et al., 2005). Also striatal activation in PD by modafinil has been shown (Scammell et al., 2000).

Two studies were conducted by Ferraro et al indicating that modafinil could have anti-parkinsonian effects on the motor symptoms of PD (Ferraro et al., 1997; Ferraro et al., 1998).

##### **1.3.6.1.2 Myotonic Dystrophy**

EDS is common symptom in myotonic dystrophy (Laberge et al., 2004). Three randomised, double-blind, placebo-controlled, crossover trials suggested positive effects of modafinil in improving EDS in patients with myotonic dystrophy (MacDonald et al., 2002; Talbot et al., 2003; Wintzen et al., 2007).

### **1.3.6.2 Psychiatric Disorders**

#### **1.3.6.2.1 Attention Deficit Hyperactivity Disorder (ADHD)**

Three placebo-controlled, open-label trials have assessed modafinil for treatment of ADHD in children. A beneficial effect of modafinil in ADHD symptoms in children in terms of increasing attention and decreasing hyperactive and impulsive behaviour was observed (Amiri et al., 2008; Boellner et al., 2006; Rugino and Copley, 2001). Two other studies also found that modafinil progressively decreases the ADHD symptoms (Biederman et al., 2006; Swanson et al., 2006). A small comparative study had conducted to explore the efficacy of modafinil with dexamphetamine and placebo in adults with ADHD (Taylor and Russo, 2000). They found that both dexamphetamine and modafinil significantly reduced the ADHD symptoms. Another study suggested a beneficial effects of a single dose of modafinil on working memory, visual memory, planning, response inhibition and sustained attention in adults with ADHD (Turner et al., 2004a).

#### **1.3.6.2.2 Depression**

Three studies have assessed the efficacy of modafinil in major depression by using different combinations of instruments (DeBattista et al., 2004; Dunlop et al., 2007; Fava et al., 2005). Two of these studies have shown considerable placebo effect, with reductions in ESS and FSS scores with both modafinil and placebo (DeBattista et al., 2004; Fava et al., 2005). However in a small study the efficacy of modafinil as adjunctive treatment for bipolar depression has been assessed (Frye et al., 2007). The result has suggested that modafinil may be helpful in bipolar depression.

#### **1.3.6.2.3 Schizophrenia**

Several studies have assessed the effect of modafinil on clinical measures in schizophrenia. Modafinil showed no greater effect on fatigue than placebo (Pierre et al., 2007; Sevy et al., 2005) and no effect (Sevy et al., 2005) or only limited effect

(Hunter et al., 2006; Spence et al., 2005; Turner et al., 2004b) on cognition performance.

#### **1.3.6.2.4 Alzheimer's disease**

A link between systemic inflammation and Alzheimer's disease has been suggested (Rogers et al., 1988). A recent study has found that the modafinil derivatives exhibit anti-inflammatory activity as evidenced by lowering of lipopolysaccharide-induced nitric oxide (NO) generation and of inflammation-related enzymes in BV2 microglial cells. They have also reported that the anti-inflammatory activity of modafinil derivatives is better than that of aspirin in the cultured cells used. These results suggest that modafinil derivatives can be developed as potential anti-inflammatory agents and a treatment strategy for Alzheimer's disease related dementia (Jung et al., 2012). In contrast, Frakey et al., (2012) have reported that the addition of modafinil to the standard of care treatment (cholinesterase inhibitor medication) in individuals with Alzheimer's disease has not resulted in significant additional reductions in apathy or improvements in performance of activities of daily living.

#### **1.3.6.2.5 Effect of modafinil on addiction and substances dependency**

##### **1.3.6.2.5.1 Cocaine**

Modafinil has been assessed for potential treatment of cocaine addiction. Modafinil could induce a decline in cocaine use (Dackis et al., 2005; Hart et al., 2008) and this more specifically in a subset of cocaine without alcohol dependence (Anderson et al., 2009). Another supporting study found that the decrease of use also was associated with longer periods of abstinence (Dackis et al., 2005).

In contrast to the previous positive results Dakis et al in a recent study had concluded that modafinil has no significant differences compared to placebo on the cocaine abstinence, cocaine craving, cocaine withdrawal, retention, and tolerability (Dackis et al., 2010, 2012).

#### **1.3.6.2.5.2 Methamphetamine**

Two studies have suggested that modafinil can increase the number of drug-free days in amphetamine dependence and it can decrease the withdrawal syndrome (McGregor et al., 2008; Shearer et al., 2009). However, Shearer et al. found no effect of modafinil on craving for methamphetamine (Shearer et al., 2009).

#### **1.3.6.2.5.3 Nicotine**

A positive role of modafinil in abstinent smokers has not been confirmed in two clinical trials; in contrast, they have reported an increase of negative effects and depressive symptoms after ingestion of modafinil (Schnoll et al., 2008; Sofuoglu et al., 2008). Furthermore, one of the trials reported that nicotine-abstinent participants smoked more with modafinil and had more withdrawal symptoms reported than non-abstinent participants with placebo, which resulted in the trial being discontinued (Schnoll et al., 2008).

### **1.3.6.3 Effect of modafinil on Disorders Associated with Fatigue**

#### **1.3.6.3.1 Chronic Fatigue Syndrome**

In a single randomised, double-blind, placebo-controlled, crossover study in patients with chronic fatigue syndrome (CFS) modafinil had inconsistent effects on the primary efficacy measure of cognition (Randall et al., 2005a), and no improvement was seen in the secondary efficacy measures of fatigue, quality of life (QoL) or mood.

#### **1.3.6.3.2 Fatigue in Post-Polio Syndrome**

A placebo-controlled study, conducted by Chan et al. revealed no significant difference between the two treatments in the terms of the ESS scores and other secondary efficacy measures (Chan et al., 2006). Another study with a relatively similar design revealed improvements in primary efficacy measures of ESS, visual analogue scale for fatigue (VAS-F) and fatigue impact scale (FIS) with both placebo

and modafinil without significant differences between the two treatments (Vasconcelos et al., 2007).

#### **1.3.6.3.3 Fatigue in Multiple Sclerosis**

Fatigue is the most troublesome symptom in MS (Fisk et al., 1994a). Modafinil has been reported to improve fatigue in patients with MS (Lange et al., 2009; Littleton et al., 2010; Rammohan et al., 2002; Zifko et al., 2002). The benefits of modafinil on the FSS were more pronounced than those previously reported with other commonly used medications, including amantadine. In patients with RR or progressive forms of MS, modafinil was associated with significant improvements on several measures of fatigue, including the fatigue severity scale (FSS), the modified fatigue impact scale (MFIS), and the VAS-F (Rammohan et al., 2002). In a supporting study Zifko et al found that a low-dose regimen of modafinil is significantly improves fatigue and sleepiness and is well tolerated by patients with MS (Zifko et al., 2002). Littleton et al (2010) have suggested that modafinil may be useful for treatment of fatigue in MS, particularly when the fatigue is associated with sleepiness. In contrast Stankoff et al found no improvement of fatigue in patients with multiple sclerosis treated with modafinil vs. placebo according to the MFIS (Stankoff et al., 2005).

#### **1.3.6.3.4 Fatigue in Parkinson's disease**

Lou (2009) had conducted a study to evaluate the subjective mental and physical fatigue in PD patients by using self-report questionnaires. The findings revealed that Levodopa and modafinil could improve physical fatigability in PD subjects. In another study Lou et al demonstrated that although modafinil may be effective in reducing physical fatigability in PD, it did not improve fatigue symptoms (Lou et al., 2009).

#### **1.3.6.3.5 Cancer-related Fatigue**

Morrow et al (2005) found that using modafinil was associated with significant improvement in fatigue severity and other measures of QoL in women who reported persistent fatigue after completion of breast cancer treatment . Kaleita et al (2006) found that modafinil significantly improves fatigue scores in people with malignant and benign brain tumours who were treated with surgery, radiotherapy, and/or chemotherapy. Spathis et al (2009) found a statistically and clinically significant reduction in fatigue and improvement of daytime sleepiness and depression/anxiety in cancer patients whom treated with Modafinil. This finding has further supported by other studies (Cooper et al., 2009; Rabkin et al., 2009).

#### **1.3.6.4 Recovery from General Anaesthesia**

A study found that patients who receive modafinil have significantly less exhaustion and they will be more alert and energetic during the stage of recovery from general anaesthesia compared with the control (Larijani et al., 2004). On the other hand studies found that the sedative effects of anti-psychotics and opiates after general anaesthesia can be reduced by modafinil (Larijani et al., 2004; Makela et al., 2003; Webster et al., 2003).

#### **1.3.6.5 Sleep-Deprived Emergency Room Physicians**

It has found that modafinil improves mood, fatigue, sleepiness and cognition in sleep-deprived healthy volunteers, and in full night shift duty physicians in emergency department (Gill et al., 2006).

#### **1.3.6.6 Effects of modafinil on quality of life (QoL)**

A study found that modafinil significantly improves the QoL (Black and Hirshkowitz, 2005), but this effect was not found in the another study (Kingshott et al., 2001).

### **1.3.6.7 Effects of modafinil on Cognitive Performance**

A positive effect of modafinil on cognition has been found in healthy young and elderly volunteers (Makris et al., 2007; Turner et al., 2003). A significant improvement in the level of alertness has been found with modafinil (Niepel et al., 2012), while a significant effectiveness on cognitive performance was not shown in the small crossover trial by using the Steer Clear (a computerised driving simulator with road obstacles which can be avoided by pressing a key) (Dinges and Weaver, 2003).

### **1.3.6.8 Effects of Modafinil in Healthy Volunteers**

#### **1.3.6.8.1 Non-sleep deprived volunteers**

Effects of modafinil have been studied in healthy volunteers under differing conditions. Studies have found improvement of cognition with modafinil in non-sleep-deprived, healthy young and elderly volunteers (Makris et al., 2007; Turner et al., 2003). In contrast, results from three studies conducted by Randall et al suggest that the benefits of modafinil are insufficient to be considered as a cognitive enhancer in non-sleep-deprived individuals (Randall et al., 2004; Randall et al., 2005b; Randall et al., 2003).

#### **1.3.6.8.2 Sleep-deprived volunteers**

The effect of modafinil in healthy sleep-deprived subjects has been evaluated in several studies. Modafinil led to improved subjective measures such as mood, fatigue, sleepiness, vigilance and improved objective measures such as reaction times, logical reasoning and short-term memory, and the Maintenance of Wakefulness Test (MWT) (Pigeau et al., 1995; Wesensten et al., 2002; Wesensten et al., 2005).



### **1.3.7 Neuroprotective aspects of modafinil**

Evidence from preclinical studies suggests neuroprotective effects of modafinil. The neuroprotective mechanisms of modafinil are unknown. Generally two groups of theories exist: the protective effect could be via modulation of neurotransmitters or could be via interference with cell death processes. The ability of modafinil to protect against degeneration of nigrostriatal dopamine neurons induced by 1-methyl-4-phenyl-1, 2, 3, 6-tetrahydropyridine (MPTP) has been suggested to be related to actions on GABAergic mechanisms of modafinil (Fuxe et al., 1992; Ueki et al., 1993a). It has also been suggested that modafinil has the ability to restore the locomotor activity in neurons already injured by MPTP, but not during the initial phase (Jenner et al., 2000). Findings from another study suggest that administration of a high dose modafinil with MPTP can selectively alter GABA binding density in the internal globus pallidus and prevents the MPTP toxicity (Zeng et al., 2004). Another supporting study suggested that modafinil prevents the decline in motor activity induced by MPTP treatment (Xiao et al., 2004). This potential neuroprotective role for modafinil in rodents was found to be mediated by antioxidant effects and modulation of nigrostriatal GABA and striatal nor-adrenaline and oxitriptan release, decreasing the GABA release and increasing the glutathione through an antioxidative process which may be independent of its wake-promoting effects (Xiao et al., 2004). These findings were supported by another study, which showed that modafinil significantly prevented the MPTP-induced change in locomotor activity, hand-eye coordination and small fast movements (van Vliet et al., 2006).

In two studies Ferraro et al have found that modafinil could normalise the disturbed balance of neurotransmitters by affecting glutamate and GABA release in specific areas of the basal ganglia through a maximal increase in glutamate release in these brain regions, associated with a lack of effect on GABA release. Furthermore, they

found that modafinil inhibits dose-dependently the activity of GABA neurons in the cerebral cortex and in the nucleus accumbens, sleep-related brain areas such as the medial preoptic area and the posterior hypothalamus (Ferraro et al., 1997; Ferraro et al., 1998).

The second group of theories addresses the interference of modafinil with cellular processes. The explanation for the mechanism of action of modafinil in the neuronal cellular processes has been argued in several studies. Taking together, the modulation of neurotransmitters by modafinil may be related to improvement of energy metabolism, synthesis and release of neurotrophic factors, recovery of calcium homeostasis, improvement in metabolic activity, free radical scavenging or stimulation of repair processes such as axonal regeneration from the surviving cell bodies (Antonelli et al., 1998; Fuxe et al., 1992; Jenner et al., 2000; Lallement et al., 1997; Ueki et al., 1993b). Modafinil stimulates the enzymatic breakdown of glutamate resulting in an increase in glutamine and a reduction in the cytotoxic effects of glutamate (Touret et al., 1994). Modafinil inhibits the cytochrome P450 enzymes particularly CYP2C9 (Robertson et al., 2000). Inhibition of cytochrome P450 enzymes reduces damage in arterial ischemia and reperfusion (Fleming et al., 2001; Granville et al., 2004). Modafinil's suppression of brain cytochrome P450 could occur through a direct intracellular site of action to suppress CYP2C9 or through enhancement of serotonin release (Ferraro et al., 2005; Tanganelli et al., 1995). These effects of modafinil could explain its ability to reduce the production of reactive oxygen species and to promote better mitochondrial function.

Piérard et al (1995) suggested that the neuroprotective effect of modafinil is due to its ability to increase the cortical pool of creatine-phosphocreatine.

Furthermore, modafinil also protects noradrenergic and serotonergic neurons against mechanical trauma induced by partial hemitranssection as well as neostriatal neurons against ischemic lesions associated with local endothelin-1 microinjection

and prevent increases in toxic aspartate and glutamate levels after striatal ischemic injury (Ueki et al., 1993a).

Modafinil prevents development of lesions in the hippocampus induced by the neurotoxic nerve gas soman (Lallement et al., 1997). A MRS study has shown the neuroprotective ability of modafinil to prevent neuronal death and prevent glutamate toxicity in cultured cortical cells (Antonelli et al., 1998). Modafinil inhibits GABA release in areas involved in the direct and indirect pathways of the basal ganglia-thalamus-cortex loop (Ferraro et al., 1997). The direct or indirect protective effects or the sustained administration of modafinil could have increased the activity of the remaining serotonergic neurons in the striatum, as modafinil does affect 5-HT levels in the brain (Ferraro et al., 2002).

Modafinil activates the histaminergic system and increases hypothalamic histamine release and c-Fos expression provided there are intact orexinergic neurons (Ishizuka et al., 2010). It has been shown that histamine, via its H<sub>3</sub> receptors has wakefulness-promoting effects, improves cognition and is neuroprotective against brain ischemia and neurodegenerative disorders (Fan et al., 2011; Stocking and Letavic, 2008). The presence of the central H<sub>3</sub> receptor is CNS-protective against experimental autoimmune encephalomyelitis (EAE), an experimental model of MS. H<sub>3</sub> receptor activation reduce the susceptibility to autoimmune inflammatory disease of the CNS (Parmentier et al., 2007; Teuscher et al., 2007).

Evidence suggests that modafinil may also act via a mechanism similar to the neuropeptides orexin-A and -B to promote histamine release (Chemelli et al., 1999; Ishizuka et al., 2003; Scammell et al., 2000).

#### **1.1.4 Summary and conclusions**

The primary aim of this thesis is to gain greater insight into the potential neuroprotective effects of modafinil in MS. In order to investigate this, we have reviewed MS in general and the literature related to the principal aim of this thesis. MS is a debilitating CNS disease in which neurodegeneration is the major determinant of the accumulation of irreversible (progressive) disability. MS has many physical and mental health consequences that limit the independence and QoL of those living with the disease. MS is a challenging disease to treat. Successful early on, DMTs eventually become partially ineffective in reducing relapses and slowing disease progression, resulting in long term disability accumulation. However, DMT may not or may only partially confer neuroprotection. Neuroprotective agents that impact directly on neuronal survival would be desirable, particularly since axonal loss and neuronal injury have been shown to be the histological correlates of neurological disability.

Evidence from preclinical studies suggests a potential neuroprotective effect of modafinil. The symptomatic benefits of modafinil have been studied in neurological, psychiatric, general medicine and even in healthy volunteers. However, its potential neuroprotection has not been extensively evaluated in persons with MS.

Part of this chapter was a review of EAE. From the pathogenesis point of view, EAE is a good model for studying MS mechanisms (Farooqi et al., 2010). The possible role of EAE in exploring the neuroprotection strategy for MS was also reviewed in this chapter and in chapter three.

Taken together, understanding the defects in the current MS treatment strategies, and the potential neuroprotective effect of modafinil encouraged us to look for developing and evaluating a new therapeutic strategy for MS. The following chapters in this thesis will attempt to shed light on this topic.

**CHAPTER 2 EXPLORING THE POTENTIAL  
NEUROPROTECTIVE EFFECTS OF MODAFINIL IN MULTIPLE  
SCLEROSIS (RETROSPECTIVE STUDY).**

## **2.1 Introduction**

Modafinil is a wakefulness-promoting agent. It has been used for treatment of narcolepsy, obstructive sleep apnoea, and shift-work sleep disorder (Robertson and Hellriegel, 2003). Modafinil has been used with varying success for symptomatic treatment in MS. The majority of these studies focused on the effects of modafinil on fatigue (Brioschi et al., 2009; Lange et al., 2009). A recent study supports a beneficial effect of modafinil in MS fatigue, particularly in the considerable proportion MS patients whose fatigue was associated with excessive daytime sleepiness (Littleton et al., 2010).

Evidence from preclinical studies suggests neuroprotective effects of modafinil. The neuroprotective potential of modafinil has been studied in animal models of neurodegenerative diseases (Antonelli et al., 1998; Jenner et al., 2000; Piérard et al., 1995; van Vliet et al., 2006; Xiao et al., 2004) (see chapter1).

These findings led us to explore, in a retrospective study, the potential neuroprotective potential of modafinil, as inferred through the impairment/disability progression, in MS, as it has been used widely in the treatment of MS related fatigue. The neuroprotective potential of modafinil, if confirmed clinically, may lead to new modalities for treating neurodegenerative diseases.

## **2.2 Methods**

### **2.2.1 Patients**

The MS clinic database at the Nottingham University Hospital was interrogated for selection of patients who had received or were receiving modafinil.

Of these, we selected patients who had been on modafinil for 3 years or more, on the assumption that a subtle neuroprotective effect may require this length of time to be recognised clinically in terms of expanded disability status scale (EDSS) change.

The demographic and clinical characteristics (age, sex, type of MS, disease

duration, follow up period and concomitant disease modifying therapies (DMT)) of these patients were obtained. For each modafinil subject three best matched MS control subjects, who had no exposure to modafinil at all, were selected based on the clinical characteristics of the patients mentioned above.

EDSS scores were recorded before the start of the modafinil treatment and at a follow-up point, at least 3 years later, in the modafinil group; and at matching time points in the non-modafinil group.

The primary parameter investigated was change in EDSS after  $\geq 3$  years of modafinil treatment or  $\geq 3$  years of follow up in the non-modafinil group.

## **2.2.2 Data Analysis and Statistics**

Descriptive statistics were used to describe the sample characteristics. R (a language and environment for statistical computing) (<http://CRAN.R-project.org/>) was used to assess differences between treated and untreated groups when other relevant covariates were considered. These covariates were age, gender, disease duration, MS type (relapsing or progressive), duration of follow up, baseline EDSS, and any history of treatment with DMTs. Covariates that did not contribute significantly to the model were removed one at a time and least significant first.

The number of patients who had an increase in EDSS of 1 step or more for EDSS  $\leq 5$  and of 0.5 or more for EDSS  $\geq 5.5$  was compared between treatment groups. For this I used Fisher's exact test using SPSS version 18 ([www.ibm.com/uk/SPSS](http://www.ibm.com/uk/SPSS)).

## **2.3 Results**

### **2.3.1 Demographic and Clinical Characteristics**

#### **2.3.1.1 Patient demographics**

Of 65 patients with clinically definite MS, according to Poser and/or MacDonald criteria, (Poser et al. 1983; McDonald et al. 2001) who had exposure to modafinil,

thirty had received modafinil for the treatment of MS-related fatigue for an uninterrupted period of 3 years or more. Modafinil dose ranged between 100mg and 400mg. Ninety matched non-modafinil treated patients were also included in this study. Patient demographics are provided in (Table 2.1) and (Table 2.2).

**Table 2.1 Demographic characteristics and clinical epidemiology of the patients.**

		Modafinil-treated patients (n=30)	Non-modafinil patients (n=90)	P value
Median(range)				
Age in years		44.5 (27-61)	45(28-61)	0.995*
DD in years		9 (4-30)	9 (3-32)	0.870**
Follow-up		4 (3-7)	4 (3-8)	0.607*
EDSS (baseline)		3 (1-6.5)	3 (0-7.5)	0.751*
EDSS (follow up)		3 (0-7.0)	4 (0-8.5)	
Gender n(%)				
Female		19 (63.3%)	60 (66.6%)	
MS clinical types n(%)	RRMS	20 (23%)	67 (77%)	0.409***
	PMS	10 (30%)	23 (70%)	
DMTs n(%)				
Yes		18 (60%)	42 (47%)	0.206***

\*t test; \*\*Mann-Whitney test; \*\*\*Chi-square test

Results are given in medians (ranges). DD; Disease duration, pre-treatment EDSS (baseline), EDSS at point of 3 years or more of modafinil treatment or follow up, RR; relapsing-remitting, SP; secondary progressive, PP; primary progressive, DMTs; disease modifying therapies.

### 2.3.2 Effect of modafinil on EDSS progression

We used general linear regression to model the EDSS change. A complete model of EDSS change included group (treatment with modafinil or not) and all potential covariates (age, sex, MS type, disease duration, follow-up period, baseline EDSS and concomitant DMTs). After stepwise elimination of non-significant covariates, the treatment group remained a significant predictor of EDSS change, as did MS type,



follow-up period, and there was a trend for baseline EDSS. We checked the model residuals for outliers and violation of the normal distribution assumptions. We further checked that the heteroscedasticity assumption of the model was not violated; in

**Table 2.2 Patient's Characteristics according to the multiple sclerosis clinical types.**

	Modafinil-treated patients (RRMS) (n=20)	Modafinil-treated patients (PMS) (Primary and Secondary) (n=10)	Non-modafinil patients (RRMS) (n=67)	Non-modafinil patients (PMS) (Primary and Secondary) (n=23)
Median(range)				
Age	41.5(27-60)	51.5(39-61)	45(28-61)	47(32-61)
DD	8.5(4-30)	14.5(7-29)	9(3-32)	10(4-28)
Follow-Up	4(3-7)	4(3-5)	4(3-6)	4(3-8)
EDSS (baseline)	2.5(1.0-6.0)	4.5 (3.0-6.5)	2.5(0.0-6.5)	5.5(3.0-7.5)
EDSS (follow-up)	2(0.0-6.0)	6(3.0-7.0)	3.5(0.0-8.5)	6.5(4.0-8.0)
Gender n(%)				
Female	14(70%)	5(50%)	51(76.1%)	9(39.1%)
DMTs n(%)				
Yes	13(65%)	5(50%)	33(49.3%)	9(39.1%)

Results are given in medians (ranges). RRMS; relapsing-remitting MS, PMS; progressive MS. DD; Disease duration, pre-treatment EDSS (baseline), EDSS at point of 3 years or more of modafinil treatment or follow-up period.

this case that the residual variance at low EDSS was similar to that at higher EDSS.

The model R squared value was 0.2;  $p < 0.00001$ .

For RRMS patients treated with modafinil, there was no significant change in EDSS (mean change  $\pm$  standard error  $-0.22 \pm 0.23$ ;  $p = 0.34$ ) over the follow-up period. For

RRMS patients not treated with modafinil, there was a significant increase in EDSS ( $0.94 \pm 0.24$ ;  $p = 0.0001$ ) over the follow-up period. Independent of modafinil treatment status, our model indicated an additional mean EDSS increase of  $1.1 \pm 0.29$  points

( $p=0.0002$ ) for progressive patients over the follow-up period i.e. mean EDSS increase was 1.1 point for modafinil treated, and  $1.1+0.94=2.04$  points for modafinil-untreated patients (Figure 2.1). There was a significant effect of follow-up period on the EDSS change, increasing it by 0.2 ( $p=0.026$ ) for every year of follow-up. The model also indicated a reduction in mean EDSS change of  $-0.15\pm 0.075$  ( $p=0.053$ ) points, for each one point increase in baseline EDSS.

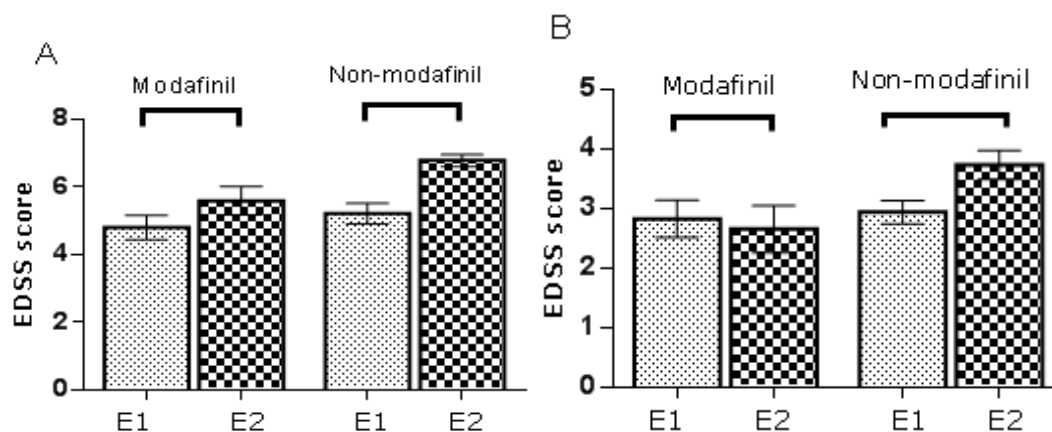

**Figure 2.1 Mean  $\pm$ SEM EDSS changes at baseline EDSS and EDSS after 3 or more years treatment or follow-up in Modafinil-treated group and non-modafinil group with progressive and RRMS.**

(A) Mean  $\pm$ SEM EDSS changes at E1 (baseline EDSS) and E2 (EDSS after 3 or more years treatment or follow-up) in Modafinil-treated group and non-modafinil group with progressive MS. (B) Mean  $\pm$ SEM EDSS changes at E1 (baseline EDSS) and E2 (EDSS after 3 or more years treatment or follow-up) in Modafinil-treated group and non-modafinil group with relapsing-remitting MS.

The Fisher's exact tests used to assess differences in proportion of subjects with increased EDSS over the study period. There was a significantly lower proportion of patients with baseline EDSS of 0-5 score who had an EDSS increase of 1 point or more and patients with baseline  $\geq 5.5$  score who had an EDSS increase of 0.5 or more point in the modafinil-treated group vs. non-modafinil group ( $p=0.017$ ) (Table 2.3).

**Table 2.3 Fisher's exact test analysis in the modafinil-treated and untreated groups have baseline EDSS 0-5 with EDSS increase by  $\geq 1.0$  point and the patients have baseline EDSS  $\geq 5.5$  score with EDSS increase by  $\geq 0.5$  point.**

Baseline EDSS	EDSS changes	Modafinil-treated patients		Non-modafinil patients		p-value
		n(%)	n(%)	n	n(%)	
$\leq 5.0$ score	EDSS changed by $< 1.0$ point	15(68.2)	18(60)	28	30(33.3)	0.017
$\geq 5.5$ score	EDSS changed by $< 0.5$ point	3(37.5)		2		
$\leq 5.0$ score	EDSS changed by $\geq 1.0$ point	7(31.8)	12(40)	43	60(66.7)	
$\geq 5.5$ score	EDSS changed by $\geq 0.5$ point	5(62.5)		17		
Total		30			90	

### 2.3.3 Evaluation the role of DMTs concomitantly received with modafinil on EDSS changes

To evaluate the possible effect of concomitant use of DMTs on the EDSS progression in modafinil treated patients. The EDSS changes in 30 modafinil-treated patients were analysed to compare the EDSS progression in those receiving DMTs vs. non- received subjects. 17 patients (56.6%) were concomitantly treated with

**Table 2.4 Mean $\pm$ SD of the EDSS1 (baseline) and EDSS2 (post treatment) in modafinil-treated patients received or not received DMTs.**

Subjects		Mean $\pm$ SEM	
		EDSS before treatment (E1) (baseline)	EDSS after 3 or more years of treatment (E2)
Modafinil-treated group n=30	Modafinil with DMTs n=17	3.47 $\pm$ 0.41	3.79 $\pm$ 0.56
	Modafinil without DMTs n=13	3.5 $\pm$ 0.44	3.8 $\pm$ 0.64

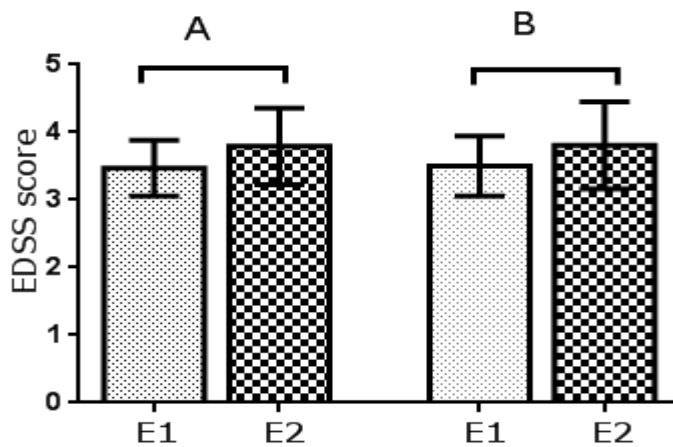

**Figure 2.2 Mean  $\pm$ SEM EDSS changes at baseline EDSS and EDSS after 3 or more years treatment in modafinil-treated group concomitantly received or not received DMTs.**

(A) Mean $\pm$ SEM EDSS changes at E1 (baseline EDSS) and E2 (EDSS after 3 or more years treatment in Modafinil-treated patients concomitantly received DMTs). (B) Mean $\pm$ SEM EDSS changes at E1 (baseline EDSS) and E2 (EDSS after 3 or more in Modafinil-treated patients not received DMTs).

DMTs and 13 patients (43.4%) were not received DMTs. The effects of DMTs were considered as the covariate was entered into the model. After backwards elimination, within the general linear model using EDSS change as the dependent variable treatment with DMTs was not significant explanatory variables in the linear model used (Figure 2.2) and (Table 2.4).

## 2.4 Discussion

The aim of this study was to explore the neuroprotective effect of modafinil in MS. This effect was suggested in studies of experimental model of neurodegenerative diseases (Antonelli et al., 1998; Jenner et al., 2000; Piérard et al., 1995; van Vliet et al., 2006; Xiao et al., 2004), and in vitro studies (Ferraro et al., 2005; Tanganelli et al., 1995; Ueki et al., 1993a).

In this relatively large, matched-groups retrospective study the most notable finding was that the ninety MS patients who had no exposure to modafinil experienced significantly greater increases in EDSS compared to thirty patients with MS who received modafinil for three and more years without interruption. This was seen in both relapsing-remitting and progressive types of MS. The EDSS increase in patients not treated with modafinil was, approximately one score point greater than in those treated with modafinil.

There was no EDSS increase in RRMS in the treated group but there was an average increase in non-modafinil RRMS group of approximately 1 point. In progressive MS, the increase in EDSS in the treated group was approximately 1 point while it was twice this figure in non-treated group. These results suggest that treating with modafinil may slow down the EDSS progression and severity of the disease.

The effect appeared more prominent in patients initiating treatment at a lower EDSS level, although the fewer patients in each treatment group with a baseline EDSS of 5 or more may explain why the differences in favour of modafinil fell short of statistical significance (Table 2.3). It is nevertheless possible that the effects of modafinil on disability/impairment progression are more beneficial if it is initiated at lower starting levels of disability.

Due to the retrospective nature of the study and the small number of well-documented relapses altogether, we cannot assess whether the effect of modafinil on progression in the less disabled group was related to any effect of relapses. However, we think it is a primary effect on the neurodegenerative component of MS (thus neuroprotective) in view of the fact that DMT, despite their proven effect on reducing relapses, did not appear to affect the progression in this cohort.

A few studies have suggested that modafinil may have neuroprotective effects in neurodegenerative diseases. Pierard et al. (1995) showed that modafinil can

increase creatinine- phosphocreatine in a rat cortical pool. Phosphocreatine can compensate for the lack of adenosine triphosphate (ATP) synthesis that is caused in the brain by deficiency of oxygen due to anoxia or ischemia. Antonilli et al. (1998) showed the ability of modafinil to reduce GABA release in the cortical neurons, which may help cell recovery after glutamate exposure. van Vliet et al. (2006) in their study in a marmoset MPTP-induced PD model suggested the role of modafinil in restoring the locomotor activity. Jenner et al. (2000) showed the ability of modafinil to attenuate or prevent the oxidative damage in neurons by neurotoxic agents.

### **Limitations of the study**

There are limitations of retrospective studies such as the one presented in this chapter. Therefore, caution needs to be exercised in retrospective cohort studies because errors due to confounding and bias are common in such studies. On the other hand, such a study may provide a proof of concept and a basis for a prospective study, and can be achieved, in a relatively inexpensive and quick manner. Also, the fact that the retrospective study was obtained on prospectively collected data (with the initial intent of studying the effect of co-morbidity in MS), makes the data more uniform and mitigates to some extent the disadvantages of the retrospective study.

The sample size of modafinil-treated patients was based on the inclusion criteria which was patients received modafinil for three and more years without interruption. A total of 30 patients were found to fulfil these inclusion criteria.

To select a non-modafinil group among those patients who have no exposure to modafinil we matched the patients one to one for all variables (age, sex, MS clinical type, disease duration, and baseline EDSS). For matching on age and disease duration controls were allowed to be in range of  $\pm 5$  and  $\pm 3$ , respectively, while exact

matching was done for other variables (Sex, MST, baseline EDSS). Eventually, we found three controls from the non-modafinil treated group for each case in the modafinil-treated patients who fulfill the inclusion criteria. Total of 90 patients were selected to be included as controls.. Increasing the number of controls up to a ratio of about 4/1 improves the power of the study. This rise is not linear, however. Beyond a ratio of about 4/1 little power improvement results from increasing the number of controls (Kearney et al., 2003).

Among other biases which can negatively impact the veracity of this type of study is selection bias (a statistical bias in which there is an error in choosing the individuals or groups to take part in a scientific study). If the selection bias is not taken into account then certain conclusions drawn may be wrong. In our cohort the decision to start modafinil treatment in patients with MS was based on the presence of subjective fatigue. This means that fatigue was a feature for all modafinil-treated patients while this was only the case for some of the included patients in non-modafinil group. Fatigue may have negative impact on disease severity in MS and may interfere with calculation of EDSS scores. This can particularly affect any of the analysed outcomes when clinical measures are the outcomes for the study

Although given in different doses, we considered modafinil as a single therapeutic class, a robust comparison between different doses would be challenging in a retrospective study like ours. Moreover our study was not designed to adjust for adverse events associated with modafinil treatment which may have had an impact on EDSS calculation.

The main outcome measure in our study was difference in the mean of baseline EDSS and last recorded EDSS after three or more years of modafinil treatment in treated group and follow up period in non-treated group. The EDSS has recognised limitations however, it is the most widely used and internationally recognised disability assessment tool in MS, its use being ubiquitous in MS clinical trials and

observational studies. Limitations relevant to the study EDSS end points include reliance on ability to walk and an inability to capture well the myriad MS symptoms (cognition; fatigue; bowel, bladder, or sexual function; visual acuity; or health-related QoL).

### **Conclusions**

In conclusion, we found evidence that administration of modafinil was associated with a reduction in disability progression in patients with relapsing-remitting MS and progressive MS.

Advances in the understanding of the mechanism of the action of modafinil and histochemistry and neuroimaging studies provide increasing evidence that modafinil has neuroprotective properties in neurological diseases including MS. Further investigation is essential.

### **Future work**

Although the result of this study supports the potential for modafinil to slow down the progression of disability in MS, the limitations of the study need to be taken into account, Prospective studies using surrogate markers of disease progression and of neuroprotection are needed to confirm this important and promising finding.



**CHAPTER 3 MODULATION OF EXPERIMENTAL  
AUTOIMMUNE ENCEPHALOMYELITIS BY MODAFINIL**

### **3.1 Introduction**

Multiple sclerosis (MS) is an inflammatory and demyelinating disease of the central nervous system (CNS) with no cure available so far. Experimental autoimmune encephalomyelitis (EAE) is a CD4<sup>+</sup> T-cell-mediated inflammatory demyelinating disease of the CNS that is commonly used as an experimental model of MS. EAE can be induced in a number of species, including mice, rats, guinea pigs, rabbits and primates. It presents with pathological and clinical features very similar to those of MS, making it amenable for mechanistic and intervention studies (Baxter, 2007; Dittel, 2008; Gold et al., 2006). Therefore, EAE has been extensively used to investigate potential therapeutics for MS.

Active immunisation with myelin antigen (active induction) and adoptive transfer of encephalitogenic T cells (passive induction) can both be used to induce EAE (Lando et al., 1980; Lassmann and Wisniewski, 1979). Of different types of myelin antigens, myelin basic protein (MBP), proteolipid protein (PLP) or myelin oligodendrocyte glycoprotein (MOG) are the most commonly used ones. Immunodominant encephalitogenic peptides can also be used for immunisation. Mice are widely used for EAE model and among different mice species suggested to be used as a model, C57BL/6 is commonly used. Active immunisation with MOG in C57BL/6 mice yields a chronic type of EAE, which is usually monophasic and followed by different degrees of recovery, which depend on specific immunisation protocols (Miller et al., 2010). C57BL/6 mice were first shown to be susceptible to MOG-induced EAE by Ben Nun's group and have since been widely used, (Ben-Nun et al., 1981; Derosbo et al., 1995), one of the advantages of this model being the availability of numerous genetically modified lines.

In both MS and EAE, T cell activation and proliferation with subsequent migration through the blood brain barrier (BBB) are thought to lead to reactivation of myelin reactive T cells by perivascular antigen presenting cells in the CNS, production of

pro-inflammatory cytokines and reactive oxygen and nitrogen species, followed by demyelination and axonal damage (Friese et al., 2006; Gold et al., 2006; Miller et al., 2010). Interventions that reduce or suppress one or more of these events should reduce both clinical and pathological symptoms and, thus, are candidates for pre-clinical and clinical evaluation.

Three of the seven food and drug administration (FDA) approved drugs for MS (Natalizumab, Glatiramer acetate, and Mitoxantrone) were clinically developed as a direct result of initial discoveries made using an EAE model. Recently, fingolimod (FTY720) had approval by FDA and became the first FDA approved oral medication for the treatment of MS. Fingolimod's success has been associated with research conducted in EAE, which has shown that fingolimod protects against disease development and causes a rapid and sustained improvement in neurological deficits [reviewed in (Lim and Constantinescu, 2010)].

Several EAE trials have conducted to test new agents including statins (Greenwood et al., 2003; Stanislaus et al., 2001; Vollmer et al., 2004; Youssef et al., 2002), peroxisome proliferators-activated receptor (PPAR) agonists (Lovett-Racke et al., 2004), laquinimod (Polman et al., 2005a; Yang et al., 2004), altered and native myelin peptides (Bielekova et al., 2000; Brocke et al., 1996) and antigen-specific DNA vaccination (Garren et al., 2001; Robinson et al., 2003).

Modafinil is a wakefulness-promoting agent, increasingly being used for the treatment of fatigue and excessive sleepiness in neurological disorders including MS, psychiatric disorders, and for cognitive enhancement. Preclinical studies suggest a potential neuroprotective effect of modafinil (Pierard et al. 1995; Antonelli et al. 1998).

Work on modafinil as possible neuroprotective agents in EAE, and therefore with potential in human MS, is very encouraging (Jenner et al. 2000; Xiao et al. 2004; van Vliet et al. 2006). The present study was designed to examine the efficacy of

modafinil in EAE induced by MOG peptide in mice and to elucidate the possible neuroprotective potential of modafinil in EAE, which is a useful animal model of chronic MS.

As part of this thesis, our aim was to perform a pilot experiment to determine whether modafinil, at doses that showed a therapeutic neuroprotective effect in vivo in other experimental systems, suppresses the clinical signs of EAE. This would represent a first, proof-of-concept, step, that would be followed in future studies (not part of this thesis) by mechanistic studies to determine whether the suppression of EAE is at least in part through a neuroprotective effect.

## **3.2 Methods and Animals**

### **3.2.1 Animals**

Nineteen 6-8 weeks old female mice (C57BL/6), purchased from Charles River, Cambridge-UK, were used in this study. Weight at the time of immunisation was 20-25g.

### **3.2.2 Peptide**

MOG<sub>35-55</sub> peptide obtained from Cambridge research biochemical, emulsified in complete Freund's adjuvant (CFA) (Difco, Detroit, MI) containing 4mg/ml killed *Mycobacterium Tuberculosis* (strain H37Ra; Difco) was used for active immunisation.

### **3.2.3 Induction of EAE**

Mice were acclimatised in individually ventilated cages. 3-4 mice were housed per cage under a 12 hour light/ dark cycle at 22°C ± 2°C and had free access to food and water for 1 week before the start of experiments. Mice were then randomly assigned to three groups, i.e., two treatment groups; group 1 (n=7) (low dose treatment group), group 2 (n=7) (high dose treatment group), and group 3 (n=5) (negative control group that were injected with vehicle only). On day 0 EAE was

induced using synthetic MOG<sub>35-55</sub>. Mice were injected subcutaneously at two sites in the back with an emulsion containing 250 µg of MOG<sub>35-55</sub> dissolved in 100 µL of phosphate-buffered saline (PBS), emulsified in CFA containing (4mg/ml killed *Mycobacterium Tuberculosis* H37 Ra). The animals then received an intraperitoneal injection of 200 ng of pertussis toxin (Sigma-Aldrich) in 200 µL of PBS. Two days later, mice received a second pertussis toxin injection. Mice were housed at 3/cage throughout the experiment.

As mentioned above, this well-established model was selected as it is thought to appropriately reflect acute paralysis in MS, followed by incomplete neurological recovery.

All animal protocols were approved by the Ethical Review Committee of the University of Nottingham. The study was performed in compliance with Home Office regulations under project licence (PPL) 40-3095 (Dr B Gran). Data were plotted as daily mean clinical score for all animals. Several parameters of disease were examined to evaluate the severity of EAE and the efficacy of modafinil therapy that include mean clinical score, peak clinical score, and histopathology.

#### **3.2.4 Treatment of mice**

Modafinil was dissolved in a warm 0.9% PBS, with 1.5% dimethylsulfoxide (DMSO). Two doses of modafinil; low (50mg/Kg) and high (100mg/Kg), were chosen. Modafinil was administered intraperitoneally in doses of 50mg/kg (low dose), and 100mg/kg (high dose). The doses chosen were based on earlier studies in marmosets, rats and mice (Duteil et al., 1990; Engber et al., 1998; Jenner et al., 2000). PBS-treated EAE mice were administration PBS only. As we look to the therapeutic effect of modafinil in EAE, and to give similarity between EAE scores and early disability in MS, the modafinil treatment started when the animals reached a clinical score of 1. Following that, treatment was given intraperitoneally, every day throughout the course of the study until mice were sacrificed at day 30 post-

immunisation. To evaluate the treatment effects on inflammation and demyelination, the lumbar spinal cords of different treated EAE mice were subjected to histopathology assay.

### **3.2.5 Clinical evaluation**

Because EAE is a progressive, ascending paralysis, daily monitoring for body weight and grading the clinical signs was needed. Blind to the treatments, the grading was done on a daily basis from day 0 (immunisation) to the day 30 post-immunisation. Mice were removed from the home cage and evaluated for tail tone, ambulation, limb weakness, and righting response. The clinical scoring scale was as follows; 0—healthy, 1—flaccid tail, 2—impaired righting reflex and/or impaired gait, 3—partial hind-leg paralysis, 4—total hind-leg paralysis, 5—any sign of front-leg paralysis, and 6—moribund/ dead (O'Brien et al., 2010). Animals were sacrificed at the end of study period. The overall disease burden of each mouse was represented as the cumulative disease severity, which was the sum of the disability scores obtained daily over the course of the 30-day experiment.

### **3.2.6 Immunohistopathological evaluation of neuroprotection potential of modafinil in EAE**

The first part of the present study (and part of this thesis) was designed to determine whether modafinil had beneficial effects on clinical severity of EAE in mice. The second part of this study (not part of this thesis) was designed to precisely determine modafinil's underlying mechanism of action in this mouse model of MS and assess its possible neuroprotective effect in this chronic demyelinating disease model. To examine the beneficial effect of modafinil and its potential neuroprotective and immunomodulatory effects in chronic EAE induced by immunisation with MOG peptide in C57/Bl6 mice the effects of two distinct doses of modafinil administered daily i.p. after the mice developed score 1 of disease severity were evaluated and compared with vehicle-treated group. In the clinical evaluation of this experiment we

found that modafinil markedly suppressed neurological deficits associated with EAE compared with vehicle-treated mice. The result revealed that modafinil significantly reduces the clinical score of severity of EAE. To look at the mechanism of action of modafinil and assess its possible neuroprotective effect in this chronic demyelinating disease model we collected spinal cord samples for histological evaluation (the spinal cord is the predominant site of pathology in this model), serum for future measurement of neurotransmitters and cytokines, spleen samples for immunological studies, and microdissected thalami for proteomics.

Using immunohistopathology, we investigate whether modafinil alleviates the infiltration of macrophages/microglia and astrogliosis and whether it prevents demyelination in the spinal cord of EAE mice. This is done with microglia specific markers such as the F4/80 antibody or CD11c antibody. We will also count axonal density using axon-specific immunohistochemistry staining with neurofilament heavy chain (NF-H) antibodies.

Altogether immunohistopathological investigations will shed light on effectiveness of modafinil in the treatment of MS and whether to be piloted in clinical trials.

#### **3.2.6.1 Histopathological Examination of EAE.**

At the end of the study (day 30), animals were anaesthetised with tri-bromo-ethanol (300 mg/kg) and then perfused through the left ventricle with cold PBS (4°C) for 3–5 min followed by 4% paraformaldehyde for 10 min. The brain and spinal cord were resected and stored in 10% paraformaldehyde at 4°C. Serial 5-µm thick cross-sections were prepared and were stained with haematoxylin and eosin to assess inflammation. In each group, at least 10 sections per mouse distributed over the whole length of the spinal cord are to be examined histologically and quantified. The sections were prepared for examination for inflammatory cell infiltrates under a microscope. Inflammation and demyelination will be scored as described (Michael, 2005) using a semi-quantitative scale. Inflammation scores are: scored 0 = no

inflammatory cells; 1 = a few scattered inflammatory cells; 2 = organisation of inflammatory infiltrates into perivascular cuffs; 3 = extensive perivascular cuffing with extension into adjacent subarachnoid space and CNS dense parenchyma; 4= extensive perivascular cuffing with increasing subarachnoid and parenchymal inflammation. Demyelination scores are: 0= no demyelination; 1= a few, scattered naked axon; 2= small groups of naked axons; 3= large groups of naked axons; 4= confluent foci of demyelination; 5= widespread demyelination.

#### **3.2.6.2 Determination of Various Cytokines/Chemokines in Serum.**

Peripheral blood was collected on day 30 from vehicle and modafinil treated EAE mice. Presence of various cytokines/chemokines will be examined in blood serum. To further examine the phenotype of inflammation, mononuclear cells will be isolated from the spinal cords of EAE mice and analysed by flow cytometry, and cells will be isolated from the spleen for analysis to assess effects on T cells in the periphery also examine the expression of these cytokines in CNS and peripheral T cells. Analyses of cytokine production in the periphery of the mice will provide insight on how modafinil can reduce Th1 and Th17 cytokines known to contribute to the development of EAE. Modafinil may suppress signal transducer and activator of transcription 3 (STAT3) and p65 nuclear factor kappa-light-chain-enhancer of activated B cells (NFκB) phosphorylation in the spleen and the brain of EAE mice. These two transcription factors regulate a large array of inflammatory genes including cytokines suggesting a mechanism by which modafinil antagonises pro-inflammatory cytokine production.

#### **3.2.6.3 Detection of modafinil-Induced Apoptosis in Primary T Cells.**

To determine modafinil-induced apoptosis in primary T cells, T cells from modafinil-treated mice will be purified from the spleens using nylon wool column (Polysciences, Inc., Warrington, PA) followed by depletion of B cells and macrophages.



#### **3.2.6.4 Statistical analysis of immunohistopathological data.**

Results will be presented as the mean  $\pm$  S.E.M. Statistical analysis for significant differences on clinical scores will be performed with the non-parametric Mann–Whitney test for the clinical course of EAE and the histopathological parameters. Statistical analyses will be performed using Mann-Whitney *U* test Student's *t* test for EAE, significant difference between control and experimental groups or two-factor ANOVA as appropriate, with a *P* value of  $\leq .05$  considered to be statistically significant.

#### **3.2.7 Statistical Analysis**

Because the data were not normally distributed, statistical analysis was performed with non-parametric tests using GraphPad Prism version 6.00 for Windows, GraphPad Software, San Diego California USA, [www.graphpad.com](http://www.graphpad.com). Descriptive analysis included, mean and SEM. Differences between two groups were assessed with Wilcoxon–Mann–Whitney U-test. Differences between three groups were assessed with One-way ANOVA, non-parametric, Kruskal–Wallis test, followed by pair-wise Wilcoxon–Mann–Whitney U-tests. Data are expressed as mean values  $\pm$  SEM. Results are reported as mean  $\pm$  SEM; *P* values  $<0.05$  were considered to be statistically significant.

### **3.3 Results**

#### **3.3.1 Modafinil ameliorated clinical severity of EAE mice**

All the mice have the first disease symptom (flaccid tail) at day 12 or 13 and this was considered a score 1 according to the clinical scoring scale (Figure 3.1). After 4-5 days the effect of the treatment with modafinil appeared which was represented by difference in clinical scores between treatment groups and control group. Mean $\pm$  SEM of the control (PBS) group was  $2.32\pm 0.23$ , mean $\pm$ SEM of the low dose-modafinil group was  $1.82\pm 0.14$ , and mean $\pm$ SEM of the high dose-modafinil group

was  $1.53 \pm 0.08$  (Table 3.1). The maximal score  $\pm$  SEM (maximum severity of disease in individual mouse) of PBS, low-dose and high dose modafinil- treated EAE mice were  $3.8 \pm 0.122$ ,  $2.78 \pm 0.285$ , and  $2.28 \pm 0.342$  respectively. The cumulative

**Table 3.1 Mean  $\pm$  SEM of the subject groups**

Group	Number	Mean $\pm$ SEM of daily clinical score	Mean $\pm$ SEM of maximum severity score	cumulative score $\pm$ SEM
Control group/EAE only	5	$2.32 \pm 0.23$	$3.8 \pm 0.122$	$43.7 \pm 6.06$
Low dose treatment group	7	$1.82 \pm 0.14$	$2.78 \pm 0.285$	$32.71 \pm 3.73$
High dose treatment group	7	$1.53 \pm 0.08$	$2.28 \pm 0.342$	$23.36 \pm 2.84$

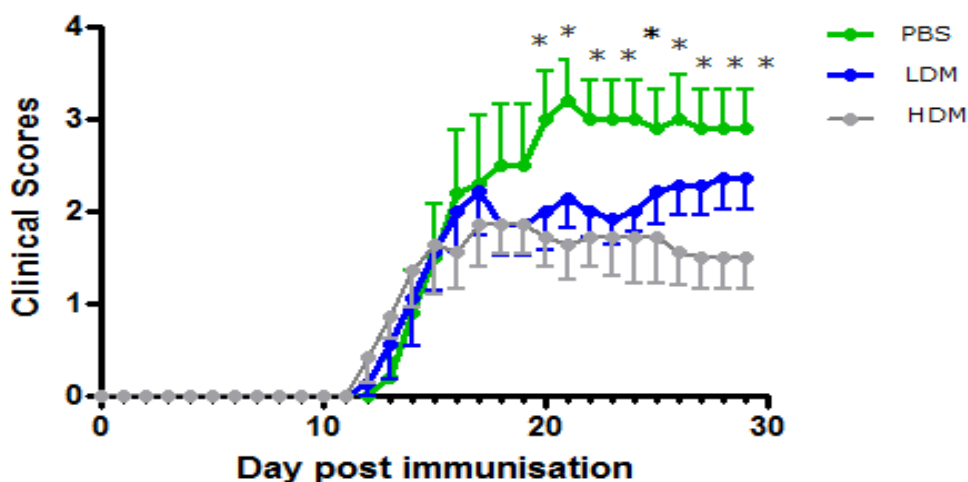
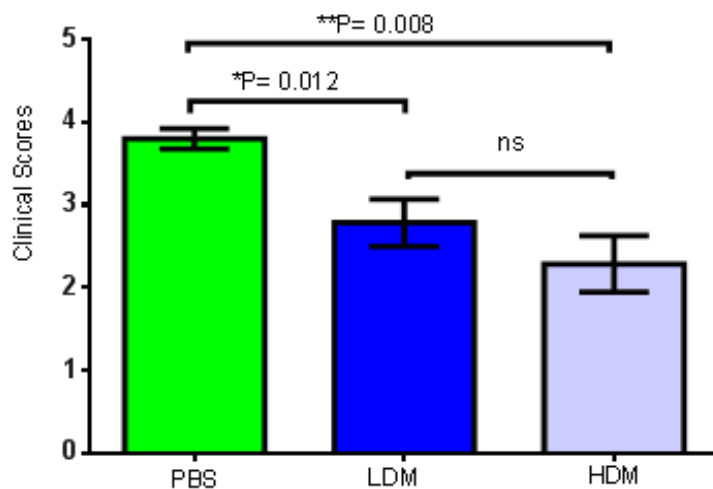

**Figure 3.1 Effect of modafinil treatment on clinical score of EAE associated disease activity**

EAE was induced in (n=19) female C57 BL/6 mice with MOG<sub>35-55</sub> and treatment with PBS and modafinil was started when the mice reached score 1 of the EAE as described under material and methods. The group (green) was treated with vehicle only. The group (blue) received low dose (50mg/kg) (1mg) modafinil and the group (gray) received high dose (100 mg/kg) (2mg) modafinil. Daily intraperitoneal injections were used in all groups until the end of the study (day 30). Animals were scored daily for clinical symptoms on a 0-6 scale. Mean clinical scores were determined for each group. One way ANOVA (Kruskal-Wallis test), Values represent the mean  $\pm$  SEM of both treated groups vs. PBS-treated group (\*\*P= 0.009).

PBS= phosphate- buffered saline; LDM= low dose modafinil-treated group; HDM= high dose modafinil-treated group; MOG= Myelin Oligodendrocyte Glycoprotein.

score $\pm$ SEM (cumulative disease severity) of PBS, low-dose and high dose modafinil- treated EAE mice were 43.7 $\pm$ 6.06, 32.71 $\pm$ 3.73, and 23.36 $\pm$ 2.84 respectively (Table 3.1). Kruskal-Wallis test found that the maximal severity and cumulative scores were significantly reduced in both modafinil-treated mice compared with PBS-treated group (p= 0.009 and 0.018 respectively). The difference in clinical scores between PBS group and both high-dose and low dose modafinil- treated EAE mice groups was statistical significance in favour of treated groups (p=0.008; p= 0.021 respectively). The effect of high dose modafinil in reducing the severity of the disease was greater than the low dose modafinil, the difference did not reach statistically significance (Figure 4.2).



**Figure 3.2 The maximum Severity of clinical course in three groups of EAE**

Mann Whitney U test, Values represent the mean $\pm$ SEM. Green bar represents PBS-treated group (control group); Blue represents Low dose (1mg) modafinil-treated mice; Gray represents high dose (2mg) modafinil-treated mice.

### **3.4 Discussion**

The neuroprotective actions of modafinil have been the focus of much attention. However, little is known about the effects of modafinil on immune inflammatory diseases such as EAE, an established model of MS. In attempt to explore the beneficial effect of modafinil on severity of EAE, and possible neuroprotective action of modafinil in this animal model of MS we conducted the present study.

The results of present study show that modafinil can significantly improve the clinical score, typically found in EAE. We observed that modafinil administration initiated at the disease onset (score 1) is effective to reduce the severity of EAE in C57 BL/6 mice when evaluated clinically.

In this study, we focused on clinical results, but have collected spinal cord samples for histological evaluation, serum for future measurement of neurotransmitter and cytokines, spleen samples for immunological studies, and microdissected thalami for proteomics.

Following the first few days of the treatment the improvement in the neurological deficits measured by clinical scores was observed in modafinil-treated mice as compared to PBS-treated EAE mice.

The dose-response experiments carried out in the present study demonstrated that modafinil is effective at the two doses (50mg/kg and 100mg/kg). The high dose-treated subject has significantly, experienced less disease severity while there was trend to decrease disease severity in low dose-treated mice.

To best of our knowledge this is the first study that has tested modafinil for its effect on disease severity in EAE. The underlying mechanism of this action is not obvious. However, modulating the neurotransmitters by modafinil and possible anti-inflammatory effect as well as the potential neuroprotective properties of modafinil might explain this promising effect.

The effect may be mediated by an effect of modafinil on mitochondria as shown before. The exact target for the action of modafinil in mitochondrion is not fully understood, however, cytochrome c has been suggested. Modafinil inhibits the cytochrome P450 enzymes particularly CYP2C9 (Robertson et al., 2000). Inhibition of cytochrome P450 enzymes reduces damage in arterial ischemia and reperfusion (Fleming et al., 2001; Granville et al., 2004). Modafinil's suppression of brain cytochrome P450 could occur through a direct intracellular site of action to suppress CYP2C9 or through enhancement of serotonin release (Ferraro et al., 2005; Tanganelli et al., 1995). Future studies will use the samples generated in this project to measure CYP1A2 and CYP2C9 as well as serotonin.

Modulating CNS neurotransmitters by modafinil could be another mode which can exert its preventive action on neuronal damage. Antonelli et al (1998) in a preclinical study have found that modafinil was able to prevent further reduction in gamma aminobutyric acid (GABA) release after initial reduction in the cells exposed to glutamate and modafinil may help cells recover their neurosecretory coupling mechanism after glutamate exposure.

Modafinil also protects noradrenergic and serotonergic neurons against mechanical trauma induced by partial hemitranssection as well as neostriatal neurons against ischemic lesions associated with local endothelin-1 microinjection (Ueki et al., 1993a). These neurotransmitters will be measured in future studies.

Treatment with modafinil has also been suggested to limit neurodegeneration associated with neurodegenerative disease and to prevent neuronal damage in models of PD (van Vliet et al., 2006). Recently, modafinil was retrospectively, tested in patients with MS (Bibani et al., 2012) this study has reported the beneficial of modafinil in reduction of diseases progression measured by EDSS in patients with MS.

A characteristic hallmark of EAE, and of MS itself, is pathological demyelination,

which results in motor deficits. To determine whether the protection conferred by modafinil treatment in the subset of modafinil-treated mice was the result of a reduction in demyelination the result of the histological examination may answer this question.

This experiment could be a start point for further study on modafinil in MS. We believe that modafinil may be a new treatment strategy for MS, perhaps with an action towards the neurodegenerative aspect of the disease.

In conclusion, this study has reported a significant reduction in the clinical scores of the severity of the EAE in modafinil treated mice in comparison with the control group. Thus, it provides an motivation for clinical trials for modafinil's therapeutic potential for MS patients. We acknowledge that there are some limitations in our experiment such as, the study is a pilot study it has limited outcome measures, we looked only at clinical scores of the disease. Barring these limitations, we conclude that modafinil is beneficial in EAE and may has protective effects against EAE.

Further work using different study outcome measures and different treatment starting points to determine both possible preventive and therapeutic effect of modafinil in EAE may confirm our finding.

**CHAPTER 4 ASSOCIATION OF A DEFICIT OF AROUSAL  
WITH FATIGUE IN MULTIPLE SCLEROSIS: EFFECT OF  
MODAFINIL**

## 4.1 Introduction

This study is based on an in-depth, complete reanalysis of data collected by Graham Niepel, a PhD student and researcher in the Division of Clinical Neurology in collaboration with the Division of Psychopharmacology (Professor Bradshaw and Szabadi). The patient characteristics, demographics, and procedures can also be found in the dissertation of Graham Niepel, entitled *Deep Gray Matter and fatigue in Multiple Sclerosis*, 2012. The focus of the thesis chapter that is based on this data is to find whether the pupillographic sleepiness test and other autonomic nervous system tests can be used as surrogate measures of fatigue in MS. Our analysis (and published paper) is focused on the effects of modafinil and the association between alertness and fatigue, as these aspects may give clues to the neuroprotective properties of modafinil (please see also Chapter six, meta-analysis). The entirely rewritten paper (G Niepel, first author) is very different from the thesis chapter, eliminates a large number of data due to its different focus, and uses parametric statistics (in contrast to the thesis chapter that uses non-parametric statistics)

Fatigue is a common symptom of MS irrespective of its clinical form (Bakshi, 2003; Krupp et al., 1988; MacAllister and Krupp, 2005). Fatigue in MS is also unrelated to the degree of physical disability or to lesion load on conventional MRI (Racke et al., 2004). Fatigue has been defined as “subjective lack of physical and/or mental energy that is perceived to interfere with usual and desired activities” (Tartaglia et al., 2004). Multiple sclerosis (MS) patients rate fatigue as one of their worst symptoms, interfering with their quality of life (QoL) and leading to disability (Janardhan and Bakshi, 2002; Krupp et al., 1988; Krupp et al., 1989). A number of clinical scales have been developed for the measurement of fatigue in MS, such as the fatigue severity scale (FSS) (Krupp et al., 1989) which is part of the Fatigue Assessment Instrument (FAI) (Schwartz et al., 1993), the fatigue impact scale (FIS)



(Fisk et al., 1994b), the modified fatigue impact scale (MFIS) (Fisk and Doble, 2002) and the neurological fatigue index (NFI-MS) (Mills et al., 2010). Only a weak correlation has been found between different rating scales, suggesting that “fatigue is a multidimensional symptom and therefore the available tests measure and weight different aspects of fatigue” (Flachenecker et al., 2003). It has been reported that fatigue in MS may be associated with increased sleepiness. The relationship between fatigue and sleepiness is complex, and some patients may report tiredness (or fatigue) when they mean “increased need for sleep” (Dement et al., 2003). The term “tiredness” may be used as euphemism for “sleepiness”. There is evidence of sleep disturbance in MS (Attarian et al., 2004; Brass et al., 2010; Constantinescu et al., 2011b; Kaminska et al., 2011; Kaynak et al., 2006) which has been implicated in the fatigue reported by patients (Kaminska et al., 2011). Disrupted night time sleep may lead to excessive daytime sleepiness (EDS). Indeed, a correlation has been demonstrated between the scores obtained on sleepiness and fatigue rating scales in MS patients with fatigue (Attarian et al., 2004).

Like fatigue, depression commonly accompanies MS, with a prevalence of up to 50% (Figved et al., 2005). Another study found that 75% of the participants with MS have complained of symptoms of depression, making it the second most common complaint after fatigue (Forbes et al., 2006). This study also found that depression and fatigue in the population with MS are interactive, but that one does not cause the other (Forbes et al., 2006).

In general, a high rate of coexistence of fatigue and depressive disorder has been identified. Several cross-sectional studies have reported an association between fatigue and depression (Bakshi et al., 2000; Ford et al., 1998; Schwartz et al., 1996). It has been shown that more than 90% of patients with major depressive disorder (MDD) had severe fatigue despite taking antidepressant medications (Ferentinos et al., 2010).

Depression is a pathophysiological concept that is related to, but distinct from fatigue. It is often hard to distinguish between fatigue and depression because fatigue can be a symptom of depression and depression can be a consequence of fatigue (Aaronson et al., 1999; Kos et al., 2008). The relationship is further confounded because instruments that measure depression generally include questions about fatigue (Aaronson et al., 1999).

Depression has been cited as a factor that causes secondary fatigue in people with MS (Kos et al., 2008). However, some researchers argue that depression does not cause fatigue in patients with MS (Egner et al., 2003; Forbes et al., 2006). Nevertheless, it is important to treat depression in patients with MS because reducing depression can lead to increased physical activity and overall improvements in health-related quality of life ((Bakshi, 2003).

Fatigue in MDD patients can appear in three distinct categories: physical, cognitive and emotional symptoms and it can be difficult to differentiate between independent symptoms of fatigue from symptoms directly related to MDD (Arnold, 2008).

As both depression and fatigue are often assumed to be related in MS, and given that both depression and MS fatigue likely have multifactorial aetiologies, and that both disorders have potentially chronic as well as episodic components, any relationship between the two is likely complex. Nevertheless, there are some explanations, which are not mutually exclusive. One is that, because fatigue is a symptom of depression, the association is due to a methodological confounder (Mohr et al., 1997). This suggests that fatigue items should be removed from depression measures when analysing outcomes. Another explanation is that depressed mood is associated with increases in self-reported severity fatigue. Furthermore, another possible explanation is that there is a common underlying MS disease mechanism responsible for both depressive mood and fatigue severity (Noseworthy et al., 2000).

MS exacerbation, which is caused by immune activation, is known to result in increases in depressive symptoms (Fassbender et al., 1998). Treatment for depression has been shown to reduce MS-related proinflammatory cytokines in MS (Mohr et al., 2001b). Thus, treatment for depression may reduce proinflammatory cytokines related to MS symptoms, thereby altering disease processes that may in part be responsible for fatigue. In MS patients with both depression and fatigue, treatment of depression may be a useful adjunct treatment, may reduce the subjective severity of fatigue symptoms (Mohr et al., 2001a).

As there is a close association between the level of arousal and autonomic activity (Samuels and Szabadi, 2008b), it is of interest that MS patients may also show disturbance of autonomic functions (Elie Louboutin, 1995; Haensch and Jörg, 2006; McDougall and McLeod, 2003; Merkelbach et al., 2006; Sanya et al., 2005). Furthermore, (Flachenecker et al., 2003) found an association between fatigue in MS and sympathetic vasomotor dysfunction.

Interestingly, autonomic dysfunction has also been reported in other conditions, such as chronic fatigue syndrome, characterized by pathological fatigue (Newton et al., 2007).

Treatment of fatigue in MS is difficult (Zifko, 2004). Recently, there has been an interest in the wakefulness-promoting drug modafinil (Ballon and Feife, 2006; Minzenberg and Carter, 2007) as a possible treatment for MS fatigue. A number of open label studies (Brioschi et al., 2009; Lange et al., 2009; Littleton et al., 2010; Nagels et al., 2007; Wilken et al., 2008; Zifko et al., 2002) and one placebo-controlled trial (Rammohan et al., 2002) have found that modafinil was efficacious in relieving fatigue in MS patients; although this was not confirmed in two placebo-controlled trials (Möller et al., 2011; Stankoff et al., 2005).

Apart from fatigue, cognitive impairment is also a common clinical feature of MS (Bobholz and Rao, 2003; Rao, 2004). Interestingly, the subjective experience of

fatigue is often associated with both subjective cognitive difficulties and demonstrable cognitive impairment, and it has been reported that modafinil may be effective in relieving not only the fatigue but also the associated cognitive deficits in MS patients (Wilken et al., 2008).

It is not clear in what way modafinil may alleviate fatigue in MS patients. It is well documented that modafinil increases the level of alertness (Hou et al., 2005; Minzenberg and Carter, 2007), and there is also evidence that the increase in alertness is accompanied by the activation of the sympathetic nervous system (Hou et al., 2005; Taneja et al., 2005).

Therefore, it is possible that the beneficial effect of modafinil on fatigue in MS patients is due to the alleviation of some symptoms (sleepiness, sympathetic dysfunction) associated with fatigue rather than to the relief of fatigue per se.

In the present study, in an attempt to explore the relationship between the antifatigue and alerting/sympathomimetic effects of modafinil, we examined whether there is any difference between MS patients with fatigue, MS patients without fatigue, and healthy controls on measures of alertness and autonomic function. We also examined the hypothesis that MS patients with fatigue may be more sensitive to the alerting and sympathetic activating effects of modafinil than MS patients without fatigue or healthy subjects. Therefore we compared the effects of a single dose (200 mg) of modafinil and placebo on measures of alertness and autonomic function in the three groups of subjects.

## **4.2 Material and Methods**

### **4.2.1 Subjects**

Three groups of subjects (MS patients with fatigue, MS patient without fatigue, healthy controls), matched for age and sex, were studied (Table 4.1).

#### 4.2.1.1 Patients

Twenty-six patients with MS, as defined by the criteria of (McDonald et al., 2001), were recruited (Table 4.1). The group distribution by clinical type of the disease was:

**Table 4.1 Characteristics of the subjects.**

Subjects	Number		Age (year) (Mean±SD)	FSS scores
	Male	Female		
Group1* Fatigue Patients	5	12	49.4±9.2	>4.1
Group 2** Non-fatigue Patients	4	5	41.8±13.1	<2.9
Group 3 Healthy Controls	4	5	40.6±12.1	-

\*14 RRMS + 3 PMS.

\*\*8 RRMS +1 PMS

RRMS= relapsing remitting MS; PMS= progressive MS

21 relapsing remitting MS (RRMS), 3 secondary progressive MS (SPMS) and 2 primary progressive MS (PPMS). There were 9 males and 17 females. All subjects were relapse and corticosteroid free for at least one month prior to commencement of the study as well as for the duration of the study. No patients suffered from any significant medical or psychiatric conditions that could confound the study. No patients had evidence of prior ocular manifestations of MS or impaired visual function, as assessed by the visual function questionnaire (VFQ25) (Noble et al., 2006).

As there can be an association between fatigue and depression (Goodwin, 1998), all patients were asked to complete the Beck Depression Inventory (BDI; (Beck et al., 1996)) prior to inclusion in the study. All patients included had BDI scores <19 (a cut-off to indicate no or mild depression). All patients were divided into two groups

according to severity of fatigue, based on their scores obtained on the fatigue severity scale (FSS; (Krupp et al., 1989). It is generally accepted that a score  $\geq 5.0$  qualifies for “fatigue”, whereas a score of  $\leq 4.0$  qualifies for “no fatigue” (Anderson et al., 2009; Bakshi et al., 2000). In our sample 16 patients had FSS in excess of 5.0 and thus fulfilled the criterion for “fatigue” (F) (Group 1). 9 patients had FSS scores less than 4.0 and thus fulfilled the criterion for “no fatigue” (NF) (Group 2). One patient had a borderline score between 4.1 and 4.9 and this patient was included in the fatigue group (Table 1). No patients with fatigue were receiving medication that could potentially affect their fatigue. Three patients in each group were receiving glatiramer acetate (GA) treatment and one patient in the NF group was receiving intramuscular beta-interferon.

#### **4.2.1.2 Healthy controls**

9 healthy control subjects were recruited to match with the patients for age and gender (Group 3). None of them had a history of neurological and/or psychiatric disease or other significant medical condition.

Approval was obtained from the Nottingham Research Ethics Committee (Appendix 1). All subjects gave informed consent.

#### **4.2.2 Drugs**

Single doses of modafinil (200 mg) and lactose placebo were administered in matching capsules.

#### **4.2.3 Design**

Each subject participated in an initial introductory session and two experimental sessions, two weeks apart. In the experimental session the subjects were allocated to treatment according to a double-blind balanced cross-over design.

#### **4.2.4 Procedure**

In the introductory session the subjects completed the fatigue and depression questionnaires, and underwent a full neurological examination by an experienced clinician.

The time-course of the experimental sessions was based on the single-dose pharmacokinetics of modafinil: peak plasma concentration is attained two hours after the ingestion of a dose (Robertson and Hellriegel, 2003). After a 30-minute acclimatisation period, the pre-treatment tests (sleepiness questionnaires, visual analogue scales for fatigue (VAS-F), pupillographic sleepiness test (PST), critical flicker fusion frequency (CFFF), choice reaction time (CRT), systolic and diastolic blood pressure, heart rate and sustained handgrip; for details, see below) were carried out. On completion of the pre-treatment tests, the subject ingested the capsule. Two hours later, the post-treatment tests (pre-treatment tests repeated and pupillometry) were carried out.

#### **4.2.5 Tests and apparatus**

##### **4.2.5.1 Tests of alertness**

###### **4.2.5.1.1 Self-rating of alertness**

For the subjective assessment of sleepiness two questionnaires Epworth Sleepiness Scale (ESS): (Johns, 1991); Stanford Sleepiness Scale (SSS): (Hoddes et al., 1973), together with a battery of VAS, were used. Subjects rated their subjective state of mood by using a computerized version of the VAS developed by (Norris, 1971). The ratings on the 16 scales were grouped under the headings of “alertness”, “anxiety”, “contentedness” based on a factor analysis carried out by (Bond and Lader, 1974).

#### **4.2.5.1.2 Instrumental measurements of alertness**

##### **4.2.5.1.2.1 Critical flicker fusion frequency (CFFF)**

The CFFF test, defined as the frequency at which a flickering light appears to be continuous (Smith and Misiak, 1976), conducted conventionally. CFFF is the level of individual sensitivity at the beginning and at the end of light flickering, caused by changes in the frequency of light flashes. CFFF is measured with the flicker test. Ascending and descending thresholds are distinguished in CFFF. The ascending (fusion) threshold is an indicator of human sensitivity to the perception of the end of light flickering. It is measured with the lowest frequency of the flashing light (Hz), at which the subject perceives a steady light instead of a flickering one. The descending (flicker) threshold is measured with the highest frequency of the flashing light when the flicker appears (Luczak and Sobolewski, 2005). The Leeds Psychomotor Tester (Psychopharma Ltd, Surrey, UK) was used to collect eight measurements of the threshold, four with increasing frequencies and four with decreasing frequencies. The mean of the eight measurements was taken as the value of CFFF for each testing session (Abduljawad et al., 1997).

##### **4.2.5.1.2.2 Pupillographic sleepiness test (PST)**

The sleepiness waves are monitored by means of a video camera with built-in infrared illumination. The person being tested wears a pair of protective spectacles which are transparent for infrared light only. The spectacles protect the eyes from any residual and visible light and only a dimmed red spot is visible for fixation. The pupil diameter is recorded up to 11 minutes. From this data the pupillary unrest index (PUI) is calculated. The PUI is a quantitative value which describes the amount of the pupillary fluctuations in darkness as a measure of sleepiness (setup version 1.20: AMTech, Weinheim, Germany) (for details, see (Hou et al., 2005)). The PST quantitatively analyses pupil diameter fluctuations, which are regarded a physiological index of level of alertness (Lowenstein et al., 1963; Yoss et al., 1970).



The method yields two measures of pupillary fluctuations, the PUI (the distance travelled by the margin of the pupil over 1 min) and the total power of the pupil diameter fluctuations (obtained from a Fast Fourier Transformation (FFT)) (Lüdtke et al., 1998).

#### **4.2.5.1.3 Psychomotor tests**

##### **4.2.5.1.3.1 Choice reaction time (CRT)**

For testing the CRT (Hindmarch, 1980) subjects were required to extinguish one of six equidistant red lights, illuminated at random, by pressing the associated response button as quickly as possible. Two components were recorded; Recognition Reaction Time (RRT) and Motor Reaction Time (MRT), which together yield the Total Reaction Time (TRT). RRT was the time it took for the subject to notice the light, the measurement being the time between stimulus onset and the subject lifting his/her finger from the start button. MRT included the majority of the movement component of this task and was the time between the subject having lifted his/her finger from the start button and touching the response button. The mean reaction times of 50 trials were recorded.

#### **4.2.5.2 Tests of autonomic function**

##### **4.2.5.2.1 Cardiovascular measures**

Blood pressure and heart rate recordings were taken in the sitting position using an electroneroid sphygmomanometer. A modified version of the method of (Ewing, 1992) was used to record the pressor response to isometric handgrip. The subject was asked to maintain his/her handgrip at 20 % of his/her maximum voluntary contraction of a handgrip dynamometer for five minutes, and the blood pressure was recorded every minute. The difference between the diastolic blood pressure just before release of the handgrip and before starting was taken as the measure of

response. An increase in diastolic blood pressure of at least 16 mmHg was taken as a normal response.

#### **4.2.5.2.2 Pupil diameter**

Resting pupil diameter was obtained using a binocular infra-red video pupillometer with a calibrated internal light source (Procyon Limited, London, UK) in darkness and at three luminance levels (6, 91 and 360 cd m<sup>-2</sup>) (for details, see (Hou et al., 2005)).

#### **4.2.6 Data analysis and statistics**

One-way analysis of variance, with group being the factor, was used to compare the performance of the three groups of subjects on the tests prior to the administration of any treatment. The differences between pre- and post-treatment scores on the individual tests were subjected to a two-way analysis of variance (treatment x group). A significance criterion of  $P < 0.05$  was adopted. If a significant F ratio was obtained, multiple comparisons were carried out using the least significant difference test (significance criterion  $P < 0.05$ ). In the case the pupil diameter data obtained post-treatment, a three-way ANOVA (luminance x treatment x group) was used.

### **4.3 Results**

#### **4.3.1 Measures of alertness**

##### **4.3.1.1 Comparison of groups prior to treatment**

Figure 4.1 shows the scores obtained by the three groups of subjects on five measures of alertness (Epworth rating scale, Stanford rating scale, VAS rating of alertness, motor component of CRT, CFFF). On all these measures there was a significant effect ( $P < 0.05$ ) of group as indicated by ANOVA (Epworth scores:  $F(2, 32) = 4.6$ ; Stanford scores:  $F(2, 32) = 7.9$ ; VAS alertness scores:  $F(2, 32) = 3.4$ ;

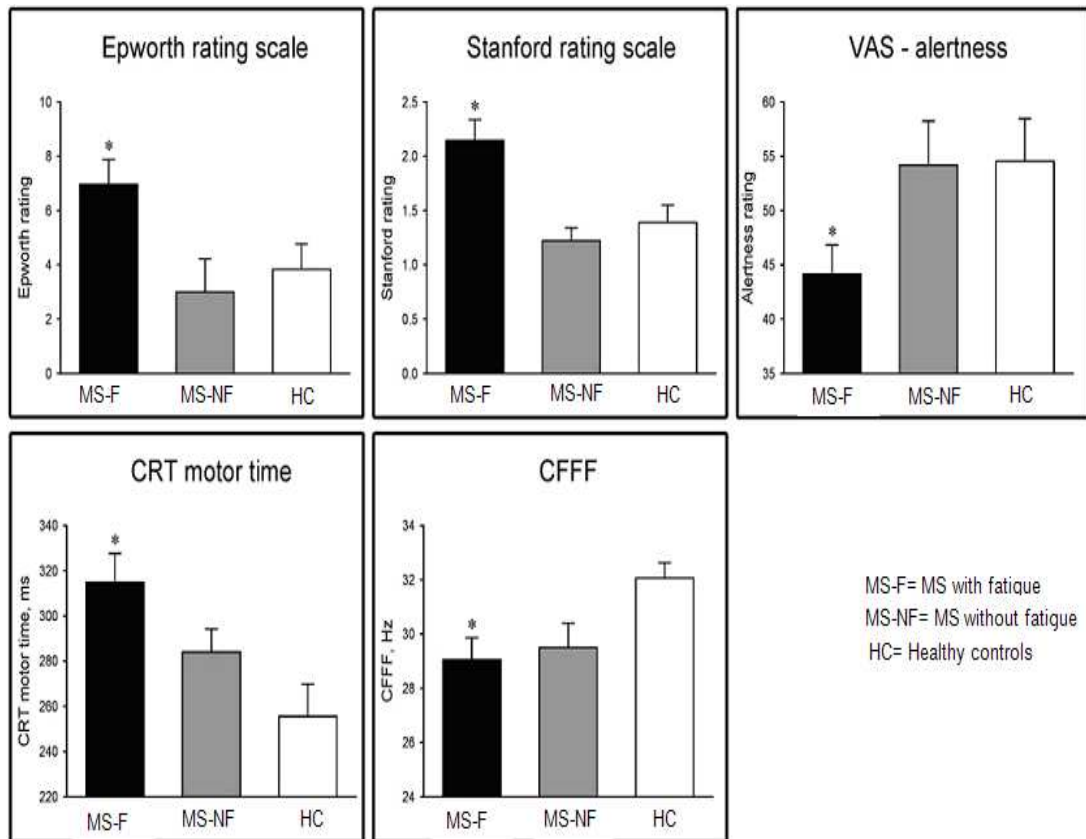

**Figure 4.1 Measures of alertness: comparison of groups prior to treatment.**

Top row: scores of subjective ratings, bottom row: instrumental measurements. Columns correspond to the three groups: black Group 1, grey Group 2, and white Group 3; vertical bars are s.e.mean. ANOVA showed a significant effect of group, and individual comparisons indicated that Group 1 was significantly different from Group 3 (\* $P < 0.05$ ) (see text for details). Higher scores on the Epworth and Stanford sleepiness scales and lower scores on VAS ratings, together with longer choice reaction times and lower thresholds of flicker fusion frequency are indicative of reduced level of alertness in Group 1 (MS patients with fatigue). In Group 1 there was a significant positive correlation between the FSS and the subjective ratings of daytime sleepiness on the Epworth rating scale ( $\rho = 0.407$ ,  $P = 0.039$ ), and a significant negative correlation between the FSS scores and the subjective ratings of alertness with the VAS ( $\rho = -0.419$ ,  $P = 0.033$ ).

CRT motor time:  $F(2, 32) = 5.0$ ; CFFF:  $F(2, 32) = 3.5$ ). Multiple comparisons (least significant difference test) indicated that the scores were significantly ( $P < 0.05$ ) higher for the Epworth, Stanford and CRT motor time scores and lower for the VAS alertness and CFFF scores in Group 1 than by Group 3 ( $P < 0.05$ ). There was no significant difference between the scores obtained in Groups 2 and 3 on any of the measures. The differences between Groups 1 and 3 on all five measures are indicative of reduced level of alertness in Group 1 compared to Group 3.

#### 4.3.1.2 Effect of modafinil

Figure 4.2 shows the pre/post-treatment differences on four measures of alertness (CFFF, CRT motor time, and two measures obtained from the PST: pupillary unrest index (PUI) and total power of pupillary fluctuations) following treatment (modafinil, placebo) in the three groups. For the PST measures one subject was excluded from Group 3 for technical reasons.

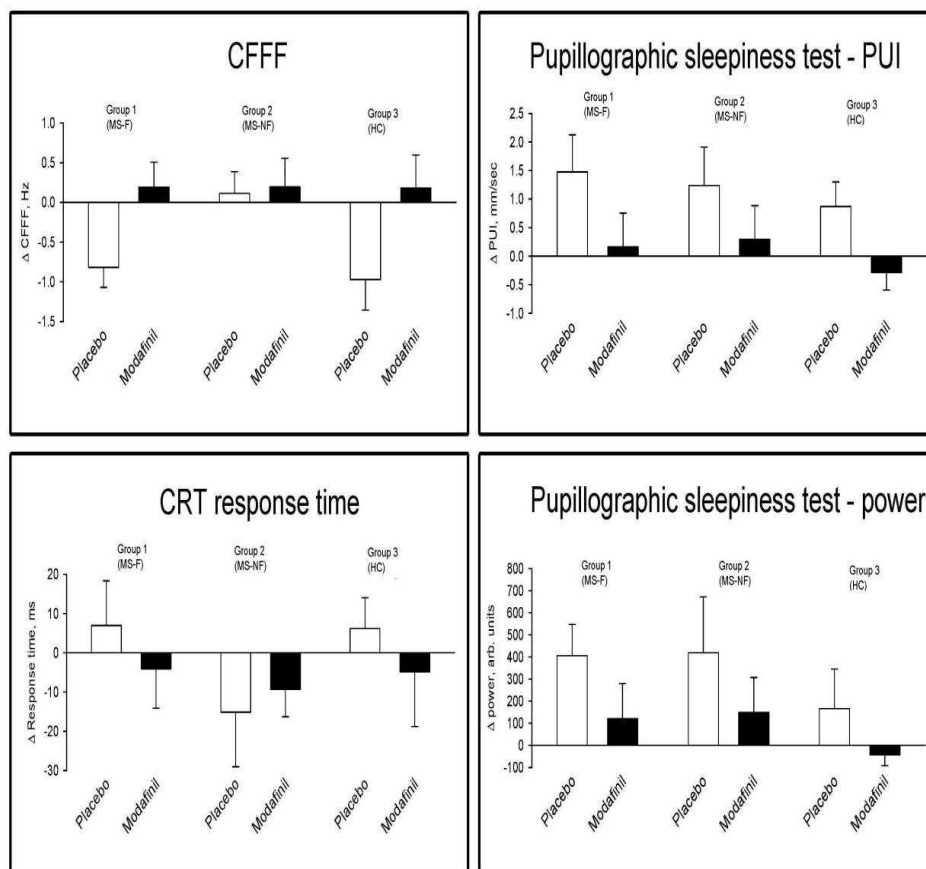

MS-F= MS with fatigue; MS-NF= MS without fatigue; HC= Healthy controls

**Figure 4.2 Measures of alertness: effect of modafinil**

Columns indicate changes from pre-treatment following the administration of placebo (white) or modafinil 200 mg (black), in the three groups; vertical bars are s.e.mean. ANOVA showed that modafinil significantly raised the flicker fusion frequency threshold, shortened choice reaction time, and reduced the two indices (PUI and total power) of sleepiness on the Pupillographic sleepiness test, irrespective of group (see text for details). The effect of modafinil was consistent with its alerting action.

The results of the two-way ANOVA (treatment x group) were as follows: *CFFF*; treatment  $F(1, 32) = 9.3$   $P < 0.05$ ; no significant effect of group and no significant interaction *CRT motor time*: treatment  $F(1, 32) = 4.6$   $P < 0.05$ ; group  $F(2, 32) = 5.6$   $P < 0.05$ ; no significant interaction; *PUI*: treatment  $F(1, 31) = 7.4$   $P < 0.05$ ; no significant effect of group and no interaction; *FFT*: treatment  $F(1, 31) = 4.5$   $P < 0.05$ ; no significant effect of group and no interaction. Visual inspection of the graphs indicates that modafinil increased *CFFF* and reduced *CRT motor time*, *PUI* and *FFT*, consistent with its alerting effect. This effect of modafinil was apparent in all three groups of subjects.

### **4.3.2 Autonomic measures**

#### **4.3.2.1 Comparison of groups prior to treatment**

Figure 4.3 (left hand graph) shows the percentage of subjects who attained the threshold criterion (i.e. an increase in diastolic blood pressure of  $\geq 16$  mmHg) in each of the three groups on the isometric handgrip test. Statistical comparison using the chi square test showed that the percentage of subjects reaching the criterion was significantly less ( $P < 0.05$ ) in Group 1 than in either Group 2 or Group 3. There was no significant difference between the three groups on any other cardiovascular measure.

#### **4.3.2.2 Effect of modafinil**

##### **4.3.2.2.1 Cardiovascular measures**

Figure 4.3 (right hand graphs) shows the effects of treatments on the pre/post-treatment differences in systolic blood pressure, diastolic blood pressure and heart rate. Two-way analysis of variance showed that there was a significant effect of treatment for all three measures: systolic blood pressure  $F(2, 32) = 8.8$   $P < 0.05$ ; diastolic blood pressure  $F(2, 32) = 15.2$   $P < 0.05$ ; heart rate  $F(2, 32) = 5.3$   $P < 0.05$ ).

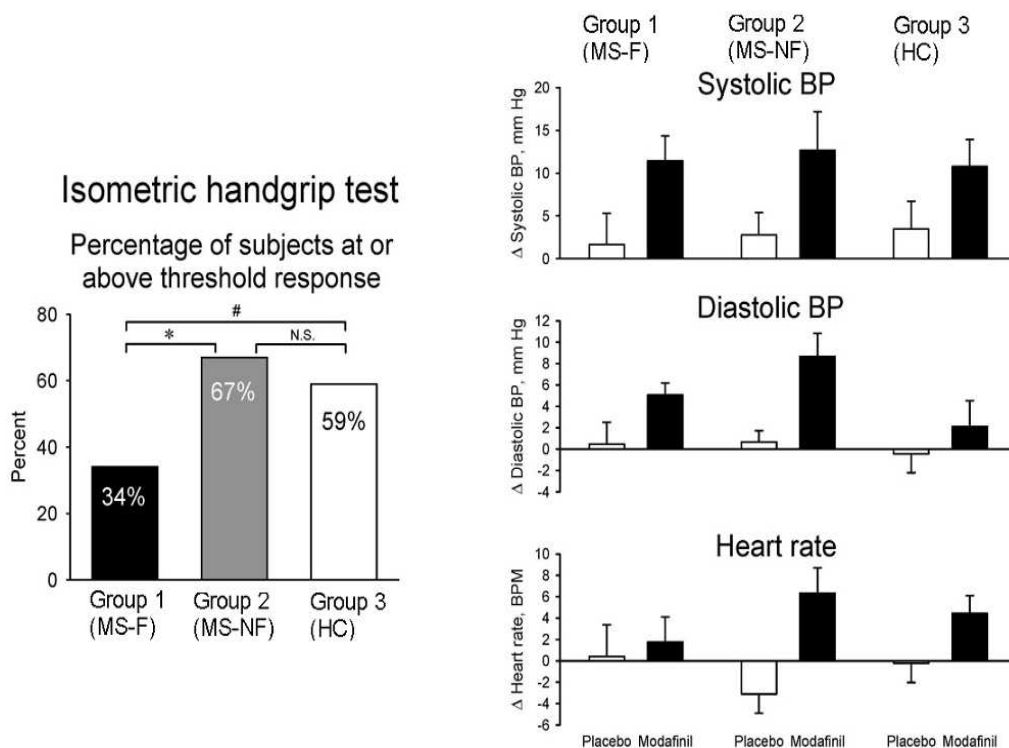

**Figure 4.3 Autonomic measures: comparison of group prior to treatment.**

Left: comparison of groups prior to treatment on the isometric handgrip test. Columns correspond to the percentage of subjects who attained an increase in diastolic blood pressure at or above the threshold (16 mmHg); black Group 1; grey Group 2, white Group 3. Brackets indicate statistical comparisons (c2 test) between the groups (\* and # $P < 0.05$ ). A significantly smaller proportion of subjects reached the threshold criterion in Group 1 than in the other two groups, consistent with reduced sympathetic responsiveness in MS patients with fatigue. Right: effect of modafinil on systolic and diastolic blood pressure and heart rate. Columns indicate changes from pre-treatment following the administration of placebo (white) or modafinil 200 mg (black), in the three groups; vertical bars are s.e.mean. ANOVA showed that modafinil significantly increased systolic and diastolic blood pressure and heart rate, irrespective of group (see text for detail), consistent with its sympathomimetic effect.

However, the effect of group was not significant ( $F < 1.0$  NS for systolic blood pressure and heart rate, and  $F(3, 32) = 1.3$  NS for diastolic blood pressure), and there was no significant treatment x group interaction in the case of any of the measures. The results indicate that the treatment effects were due to increases in

systolic and diastolic blood pressure, and heart rate by modafinil, and this effect was present irrespective of group.

#### 4.3.2.2.2 Pupil diameter

Figure 4.4 shows the relationship between luminance intensity and pupil diameter following treatment in the three groups. Three-way ANOVA (light intensity x treatment x group) was used to analyse the data. There were significant main effects of light intensity ( $F(3, 96) = 407.5 P < 0.05$ ) and treatment ( $F(1, 32) = 5.1 P < 0.05$ ), but not of group ( $F(2,32) = 1.7 NS$ ).

There was a significant interaction between light and treatment ( $F(3, 96) = 3.1 P < 0.05$ ); the interactions between light and group ( $F < 1.0 NS$ ), and treatment and group ( $F < 1.0 NS$ ), and the three-way interaction ( $F < 1.0 NS$ ) were not statistically significant. The analysis indicates that modafinil increased pupil diameter irrespective of group.

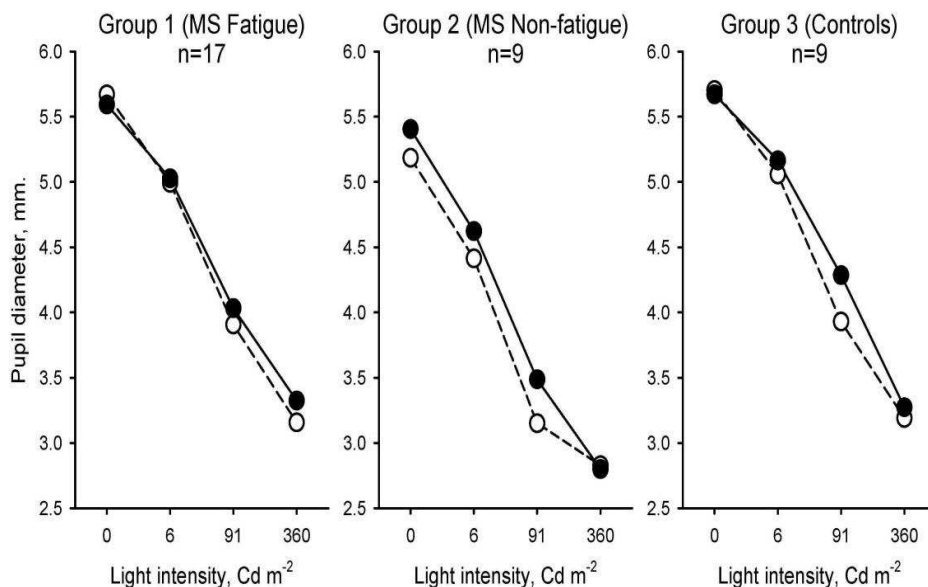

**Figure 4.4 Relationship between light intensity and Pupil diameter**

Relationship between light intensity (cd m<sub>2</sub>) and pupil diameter (mm) 2 h after the ingestion of a single dose (200 mg) of modafinil (closed symbols) or placebo (open symbols), in the three groups. ANOVA revealed that there was a significant effect of treatment but not of group (see text for details). The treatment effect was due to pupil dilatation in response to modafinil, consistent with its sympathomimetic effect.

### **4.3.3 Subjects' verbal reports**

At the end of each session, subjects were asked about their subjective experiences during that session. The debriefing was unstructured, and no leading questions were used.

Both the subject and the experimenter were blind to the medication applied in the session.

In general, subjects reported feeling a bit more "active" in sessions involving modafinil, in agreement with the quantitative assessments of alertness by both subjective and objective tests (see figure 4.1). However, there was no obvious difference between the reports of patients and healthy controls.

## **4.4 Discussion**

As reviewed in the Introduction, it has been reported that MS patients often suffer from disturbed night time sleep which can lead to EDS. Although EDS has been implicated in the symptom of fatigue in MS (Attarian et al., 2004; Kaminska et al., 2011), it is not clear whether the EDS is specifically associated with fatigue in MS or whether it also occurs in some MS patients who do not suffer from fatigue. Therefore we compared a number of subjective and objective measures of alertness between three groups of subjects: MS patients with fatigue, MS patients without fatigue and healthy controls. We found that MS patients with fatigue showed evidence of reduced level of alertness on a number of subjective (ESS, SSS, visual analogue ratings of alertness) and objective (motor component of CRT, CFFF) measures of alertness, in contrast to MS patients who did not suffer from fatigue and healthy controls. In fact, there was no significant difference between MS patients without fatigue and healthy control subjects on these measures. Our observation indicates that it is fatigue in MS rather than MS per se that is associated with a



reduced level of alertness in some MS patients. Indeed, we found a significant positive correlation between fatigue ratings on the FSS of patients in Group1 and their subjective ratings of daytime alertness on the ESS, and a significant negative correlation between the FSS scores and the measures of alertness obtained on the VAS. Fatigue (subjective lack of physical and/or mental energy) and sleepiness (increased need for sleep) are different entities (see Introduction). The relationship between fatigue and sleepiness is likely to be complex. Some patients may refer to fatigue when they are only sleepy (see Introduction), some patients' fatigue ratings may be aggravated by the experience of sleepiness, and finally in some patients fatigue and sleepiness may co-exist without any interaction between them.

Due to the close association between level of arousal and autonomic activity (Samuels and Szabadi, 2008b), it was of interest to examine whether the MS patients with fatigue, who show evidence of reduced level of alertness, differ from the other two groups on measures of autonomic activity. While there was no difference between the three groups on baseline measures of autonomic function, a significant difference was identified on a measure of evoked sympathetic activity. We found that MS patients with fatigue showed a reduced diastolic pressor response on the isometric handgrip test, compared with the other two groups, consistent with reduced sympathetic activation (Ewing, 1992; Wallin, 1992).

As reviewed in the Introduction, the wakefulness-promoting drug modafinil has been reported to be able to alleviate fatigue in MS patients. It is well documented that a single dose of modafinil increases laboratory measures of alertness and sympathetic activity in human subjects (Hou et al., 2005; Taneja et al., 2005), and the present results show that MS patients with fatigue have decrements on measures of both alertness and sympathetic activity. Therefore, we hypothesized that MS patients with fatigue might be more sensitive to the alerting and sympathetic activating effects of modafinil than MS patients without fatigue or healthy control

subjects. Modafinil displayed both alerting and sympathetic activating effects in the present study, however, the size of increase in alertness and sympathetic measures did not differ between the three groups. As MS patients with fatigue had a lower pre-treatment baseline on both alertness and sympathetic measures, it is likely that modafinil exerted a “correcting” effect on these measures, alleviating the negative subjective experience of EDS in these patients. It would have been of interest to obtain some measure of the effect of a single dose of modafinil, which had marked effects on alertness, on subjectively experienced fatigue in patients in Group 1. However, this was not feasible for two reasons: firstly, the fatigue rating scales measure fatigue as a trait and not a state at a particular point in time and secondly any anti-fatigue effect of modafinil has been reported after the administration of more than one dose for several weeks (Littleton et al., 2010; Rammohan et al., 2002; Zifko, 2004). As argued above, if the experience of excessive sleepiness is associated with the experience of fatigue in some patients, the alleviation of sleepiness is likely to lead to a reduction in subjectively rated fatigue. Therefore the therapeutic efficacy of modafinil in MS-related fatigue may be secondary to its efficacy in relieving EDS in these patients. This proposal seems to be supported by the results of a clinical study which concluded that “modafinil may be useful [for the treatment of MS-related fatigue] particularly when MS fatigue is associated with excessive sleepiness” (Littleton et al., 2010).

The pathological changes and physiological mechanisms underlying fatigue in MS are poorly understood (Comi et al., 2001b; Leocani et al., 2008). A number of mechanisms have been suggested, such as increased levels of cytokines, dysregulation of the hypothalamic pituitary- adrenal axis and axonal loss (for review, see (Braley and Chervin, 2010).

Furthermore, the dysfunction of the basal ganglia has been proposed as the pathological basis of fatigue in MS (Télliez et al., 2008). A recent finding is of

particular interest since it may shed light on the development of EDS in MS. It has been found that the central noradrenergic nucleus, the locus coeruleus (LC), is damaged in MS (Polak et al., 2011), and it is well documented that this nucleus plays a pivotal role in the maintenance of arousal and sympathetic activity (Samuels and Szabadi, 2008b). Therefore the EDS in MS patients, and in particular in MS patients with fatigue, may be the reflection of reduced central noradrenergic activity resulting from LC damage.

There has been considerable controversy surrounding the mode of action of modafinil. While modafinil, similarly to amphetamine, increases alertness and is an effective treatment of EDS in narcolepsy, in contrast to amphetamine, it has relatively little addictive potential (Szabadi and Samuels, 2008). Therefore, it was proposed that modafinil is likely to have a mode of action that is different from that of amphetamine (Ballon and Feife, 2006; Ferraro et al., 1997; Gerrard and Malcolm, 2007; Minzenberg and Carter, 2007; Saper and Scammell, 2004). It is well established that the main action of amphetamine is the release of dopamine from nerve terminals together with the inhibition of the re-uptake of dopamine into nerve endings (Szabadi and Samuels, 2008). Although a number of possible mechanisms have been implicated in the mode of action of modafinil (Ballon and Feife, 2006; Gerrard and Malcolm, 2007; Minzenberg and Carter, 2007), there is accumulating evidence that modafinil, like amphetamine, is a “dopaminergic” drug, acting mainly by inhibiting the reuptake a dopamine into dopaminergic nerve terminals (Madras et al., 2006; Volkow et al., 2009; Wisor et al., 2001; Zolkowska et al., 2009). This action of modafinil is likely to be most pronounced in the dopaminergic arousal system (see Figure 4.5), leading to the wakefulness-promoting effect of modafinil, with relative sparing of the mesolimbic dopaminergic system, responsible for mediating the addictive property of dopaminergic drugs (Samuels et al., 2007).

It has been reported that modafinil increases the release of histamine, a potent

wakefulness-promoting neurotransmitter in the hypothalamus (Ishizuka et al., 2003). Histamine is located in neurons in the tuberomammillary nucleus (TMN), a major wakefulness-promoting nucleus, in the hypothalamus. The TMN is under inhibitory GABAergic control from the ventrolateral preoptic nucleus (VLPO) of the anterior hypothalamus.

The VLPO is a major sleep-promoting nucleus, whose activity is kept in check by an inhibitory output from the LC (Hou et al., 2007). Therefore the enhancement of the dopaminergic stimulation of the LC by modafinil would lead to an arousal-enhancing cascade: LC activation would lead to inhibition of the VLPO; this in turn would result in the release of the TMN from GABA-ergic inhibition, and finally the activation of the TMN, would lead to an alerting effect (Figure 3-5). The wakefulness-promoting orexinergic neurons of the lateral hypothalamic/perifornical area (LH/PF) are also likely to contribute to the alerting effect of modafinil. Via an excitatory projection to the LH/PF, dopaminergic neurons of the ventral tegmental area stimulate orexinergic activity (Szabadi and Samuels, 2008).

Orexinergic neurons enhance wakefulness partly by a direct projection to the cerebral cortex, and partly by projections to other wakefulness-promoting nuclei, such as the LC and TMN (Samuels and Szabadi, 2008a). The importance of the facilitation of TMN activity via the orexinergic neurons has been demonstrated experimentally: modafinil fails to enhance histamine release after destruction of the orexinergic neurons (Ishizuza et al., 2012; Ishizuka et al., 2010). As fatigue in MS is associated with a reduced level of alertness, and modafinil is a wakefulness-promoting drug, the anti-fatigue effect of modafinil in MS may be related to the alleviation of EDS in these patients. It is an intriguing possibility that the reduced level of alertness in MS patients with fatigue may result from damage to the LC brought about by the disease process (Polak et al., 2011).

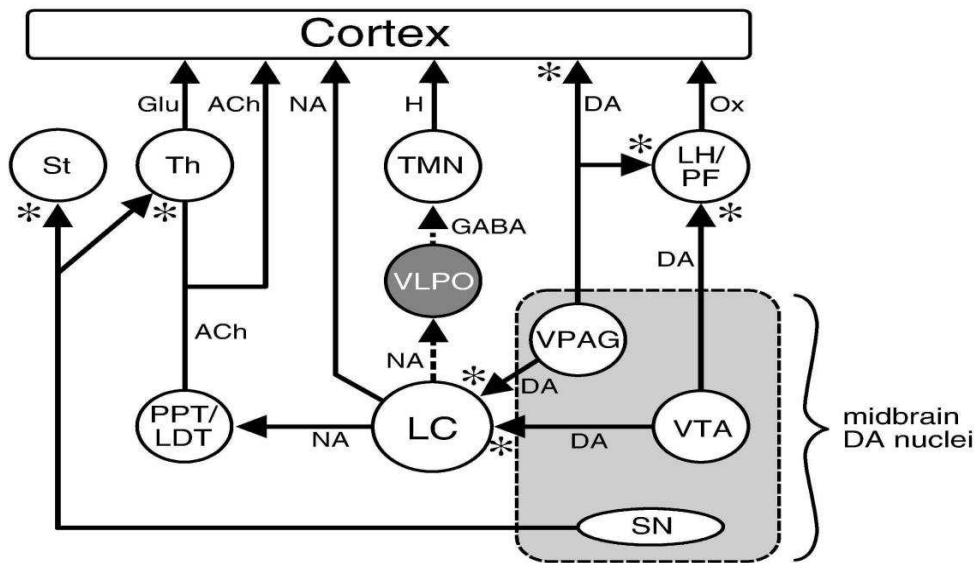

**Figure 4.5 Schematic diagram of the dopaminergic arousal system showing the possible sites of action of modafinil.** Source (Szabadi, 2006).

The level of arousal at any one time reflects the balance between the activities of a number of subcortical “wakefulness-promoting” and “sleep-promoting” nuclei [for details, see references 1 and 2]. Encircled letters in the figure indicate the arousal-modulating nuclei: white e wakefulness-promoting, dark grey e sleep-promoting. Some of the major wakefulness-promoting nuclei, that project directly to the cerebral cortex, include the glutamatergic intralaminar nuclei of the thalamus (Th), the histaminergic tuberomammillary nucleus (TMN) and the orexinergic lateral and perifornical areas (LH/PF) of the hypothalamus, the cholinergic peduncolopontine/laterodorsal tegmental nuclei (PPT/LDT) and the noradrenergic locus coeruleus (LC) of the pons, and the three dopaminergic nuclei of the midbrain: ventral periaqueductal grey (VPAG), ventral tegmental area (VTA), pars compacta of the substantia nigra (SN). The major sleep-promoting nucleus is the GABAergic ventrolateral preoptic nucleus of the hypothalamus. Arrows correspond to projections from the nuclei: solid arrow e excitatory; broken arrow e inhibitory. Letters next to each arrow designate the neurotransmitter utilised by the projection: Glu e glutamate; ACh e acetylcholine; H e histamine; DA e dopamine; Ox e orexin; NA e noradrenaline. The three midbrain dopaminergic nuclei (highlighted in figure) promote wakefulness by projecting to the cerebral cortex and to other wakefulness-promoting nuclei. The VPAG is active during wakefulness and quiescent during sleep, and projects directly to the cerebral cortex, the LH/PF and LC [3]. The VTA projects to the LC [4] and LHA/PF [5; 6].

The SN projects to the striatum (St) via the nigrostriatal pathway which sends collaterals to the Th [6]. Modafinil would exert its alerting effect by blocking the reuptake of dopamine, and thus making more neurotransmitter available for transmission, at the sites indicated by asterisks (\*). Increased LC activation is likely to be important since the LC, apart from directly stimulating the cerebral cortex, also removes the inhibitory influence of the VLPO on the TMN, leading to increased histaminergic activation of the cortex [8]. References: 1. (Szabadi, 2006); 2. (Lin et al., 2011); 3. (Lu et al., 2006); 4. (Deutch et al., 1986); 5. (Yoshida et al., 2006); 6. (Bubser et al., 2005); 7. (Freeman et al., 2001); 8. (Hou et al., 2007).

As modafinil is a powerful activator of the LC (Hou et al., 2007; Minzenberg et al., 2008) via the dopaminergic system (see Figure 4.5), modafinil may exert its therapeutic effect on MS fatigue by correcting deficient LC activity. In conclusion, we have found that MS patients with fatigue have reduced levels of alertness and sympathetic activity, and suggest that modafinil may exert its anti-fatigue effect by correcting these deficiencies, probably via the activation of the noradrenergic LC.

**CHAPTER 5 CEREBROSPINAL FLUID OLIGOCLONAL BAND  
AND MULTIPLE SCLEROSIS PROGRESSION: A  
RETROSPECTIVE STUDY**

## 5.1 Introduction

Antibody-mediated inflammation is believed to contribute to tissue injury in multiple sclerosis (MS). The majority of patients with MS have oligoclonal bands (OCB), corresponding to antibodies against a variety of antigens, in their CSF. Up to 95% of MS patients in Northern Europe have OCB in the cerebrospinal fluid (CSF), but this frequency varies depending on laboratory routines, study populations and was recently also related to latitude (Lechner-Scott et al., ; Link and Huang, 2006). The absence of OCB in CSF has been claimed to be associated with a better (Joseph et al., 2009), worse (Siritho and Freedman, 2009) or equal (Lourenco et al., 2012) clinical outcome compared to OCB positive MS.

During the process of data collection for our retrospective study detailed in chapter 2 aiming to explore the potential neuroprotective effect of modafinil in patient with MS, the Nottingham University Hospital. (NUH) MS database was reviewed. The NUH MS database is a hospital database of all MS patients attending the QMC MS Clinic, where patients are followed by three specialists in neurology at different intervals when visits are necessary. Therefore, we identified all patients in the QMC MS database, who had undergone a lumbar puncture as part of their diagnostic workup, and we included only patients who have had recorded OCB status. Other variables (age, gender, date of first disease onset, Onset type of MS, disease duration, last recorded EDSS scores and MSSS) were also recorded. As disease progression was the primary outcome for our retrospective study and on the assumption that OCB status may have interfered with disease progression and has had affected the recorded EDSS scores of included patients in our cohort and could affect the outcome of the study we evaluated the role of OCB status on disease progression. We took advantage of the statistical method (linear regression model) we used in analysing the data assessing the effect of modafinil on EDSS progression and we



applied same method evaluate the role of OCB status on disease progression in patients diagnosed with MS in our cohort.

OCBs are IgG immunoglobulin secreted by plasma cells into the CSF and can be detected using IEF technique in combination with Western blotting. Intrathecally synthesised OCBs in CSF are the immunological characteristic of MS, found in over 85-95% of the patients (Idiman et al., 2009). IEF is regarded as the gold standard for detection of intrathecal synthesis of IgG (Beckett et al., 2010). The detection of CSF OCBs by IEF is not absolutely specific for MS as CSF OCBs can be detected in a variety of other inflammatory disorders of the CNS. Despite vast improvement in MRI techniques for diagnosis of MS, CSF examination for detection of OCBs remains a valuable measure especially, in the diagnosis of primary progressive MS (PPMS). The presence of OCBs is used in conjunction with clinical evidence to help satisfy the requirement for “dissemination in space” of the previous Poser criteria. Currently, positive CSF for OCBs and 2 or more MRI lesions satisfies the revised diagnostic McDonald criteria, when MRI lesions alone do not suffice (Polman et al., 2011).

Different studies have reported different frequencies of OCBs in CSF of the MS patients between countries and even in the same country. There are reports that OCB are more likely to be detected in MS patients in the UK, USA and Scandinavia (95%, 90%, and 100% respectively) (Fortini et al., 2003; Kostulas et al., 1987; McLean et al., 1990) compared to patients in the Czech Republic and southern Europe (81%, and 83% respectively) (Bednarova et al., 2005; Sa et al., 2005). The occurrence of CSF OCB in Japan and some other Asian countries is less frequent (53%-77%) (Kikuchi et al., 2003; Nakashima et al., 2005).

The role of OCB and its prognostic value in MS has been studied previously. There were conflicting results to support the use of OCBs as predictors of disease course or progression. Some of these studies have suggested that MS patients lacking CSF

OCBs are purported to have a milder course of disease and less disability (Sa et al., 2005; Stendahl-Brodin and Link, 1980; Zeman et al., 1996). It has also been suggested that fewer OCB are attributed to lower numbers of active plaques and plasma cells in white matter and the meninges (Farrell et al., 1986). One study described a significant delay in disability progression during treatment with interferon-beta in the subgroup of MS patients with no CSF OCB detectable by IEF compared to the patients with detectable OCBs also have shown the absence of OCB which also was associated with lower numbers of baseline T2-weighted MRI lesions (Annunziata et al., 2006)

In a relatively new case-control study a slightly better prognosis measured as the hazard ratio to reach EDSS milestones of 4 and 6, of OCB-negative patients compared with OCB- positive was reported (Joseph et al., 2009).

On the other hand the prognostic significance of OCBs in MS has been disputed by several studies (Koch et al., 2007; Lourenco et al., 2012; Siritho and Freedman, 2009). These studies have found that OCBs in the CSF were not associated with either worsening or stability of disability in patients with MS, and OCB negative patients did not have more benign form of MS.

The association of OCB status with MS clinical course (relapsing-onset MS vs. progressive onset MS) has been assessed too. Some studies have suggested more OCB positivity with PPMS (Fukazawa et al., 1998; Imrell et al., 2006; Kikuchi et al., 2003; Trojano et al., 1987). In contrast the above suggested association has not supported by other studies and even they found a reverse association, i.e. patients with relapsing-remitting MS (RRMS) being more likely to present with OCBs than those with PPMS (Ford et al., 2002; Siritho and Freedman, 2009).

In the present study we aimed to: - assess the association of OCB status (the primary focus), with disease progression (measured by EDSS scores and MS

severity score (MSSS)) and OCB status with disease course (RRMS vs. PPMS), as well as effect of OCB status on time to definite diagnosis (secondary focuses).

## **5.2 Methods**

### **5.2.1 Subjects and Setting**

Study subjects were obtained from a well-documented clinical cohort of MS patients held by NUH. Patients included in this study are those with clinically definite MS (CDMS) diagnosis according to the Poser and/or MacDonald criteria with the recorded results of CSF OCBs investigation provided by the hospital diagnostic database. Patients in this cohort are seen regularly and undergo extensive medical and neurological examination. The database includes general demographic data as well as MS specific information including records of first symptom, onset date, test results, type of MS, EDSS score, MSSS, and records of use of disease modifying treatments (DMT).

### **5.2.2 Data used and main outcome measures**

Age, sex, onset age, date of OCBs results, initial type of MS, use of DMTs and last recorded EDSS were obtained. DMT use was modelled as a binary variable for use of less than a year ( $<1$ ) or one year and more ( $\geq 1$ ). Last recorded EDSS score was used to score the disability in patients. In this study disease duration was defined as the time interval between the date of last obtained EDSS score and the date of the first manifestation of the disease. We also calculated the diagnostic delay by measuring the time gap between the diagnosis date and date of the onset of the initial symptoms. MSSS was calculated according to guidelines by Roxburgh et al (Roxburgh et al., 2005). EDSS score and MSSS were used as two main measures of disease progression and severity.

### **5.2.3 Study design**

On the basis of the positivity and negativity of OCBs in the CSF, the sample was divided into two groups (a patient is considered positive for CSF OCB if there are two or more bands in the CSF immunoglobulin region that are not present in the serum). We compared the proportion of positive and negative OCB results for 1980-2010 time periods. The correlation of diagnostic delay and the results of OCBs was investigated by comparing the median delay time in two OCB groups. We also measured the effects of OCBs results on clinical outcomes. The independent effects of OCBs on EDSS score and MSSS were measured while controlling for potential confounders including sex, age, disease duration, MS initial type and treatment.

### **5.2.4 Statistical analyses**

Descriptive statistics were used to compare and summarise the data. Non-parametric test (Mann Whitney U test) was used to compare ordinal independent variables such as EDSS, and Student t test to compare means of normally distributed independent variables. We used the logistic regression model to estimate the odds of having progressive clinical course at disease onset (PP vs. RR) while controlling for onset age and gender. The effects of OCB status on EDSS and MSSS were calculated using linear regression models with adjustment for potential confounding variables (age at onset, gender, use of DMTs and disease duration). Linear models were tested for underlying normality assumption. Statistical analysis was performed using STATA software (StataCorp. 2009. *Stata Statistical Software: Release 11*. College Station, TX: StataCorp LP).

## **5.3 Results**

The final sample consisted of 434 (283 female and 151 male) CDMS patients. 348 (80%) of cases were reported as OCB positive and 86 (20%) were OCB negative. The mean (SD) age of MS onset was 34 (10) years and mean (SD) disease duration

was 14.7 (9) years. 50% of patients were RR, 33% SP and 17% were PP (Table 5.1).

**Table 5.1 Demographic and clinical characteristics of the patients.**

	OCB Negative <i>n</i> =86	OCB Positive <i>n</i> =348
Gender		
Female (%)	53 (61%)	230 (66%)
Age (Mean( $\pm$ SD))	52.26 ( $\pm$ 11.42)	47.83 ( $\pm$ 11.10)
Disease duration (Mean( $\pm$ SD))	18.54 ( $\pm$ 10.17)	13.81 ( $\pm$ 8.53)
Age at the first symptom (Mean( $\pm$ SD))	33.69 ( $\pm$ 10.14)	34.01 ( $\pm$ 10.53)
EDSS <sup>2</sup>	5.5(1-9)	6(0-8.5)
Type		
RR ( <i>n</i> =218)	36 (16.5 %)	182 (83.5 %)
SP ( <i>n</i> =142)	32 (22.5 %)	110 (77.5 %)
PP ( <i>n</i> =74)	18 (24.3 %)	56 (75.7%)
DMT $\geq$ 1 ( <i>n</i> =161)	33 (20.5%)	128 (79.5 %)

<sup>1</sup>Mean( $\pm$ SD),

<sup>2</sup>We used Median and Range due to ordinal nature of EDSS

### 5.3.1 Association between OCB status and disease progression

We compared the disability progression in the two OCB groups as measured by EDSS score and MSSS. As the comparative variables measured in different units, to determine the relationship between OCBs and EDSS scores or MSSS we looked at the beta coefficient ( $\beta$ ) for each of EDSS scores and MSSS. The OCB positive group had a higher median EDSS score (6 vs. 5.5), but after controlling for sex, age, disease duration, treatment and initial type of MS, we were unable to find any significant influence of OCB status on the EDSS score ( $\beta = 0.29$ ,  $P=0.19$ , 95%CI=-0.14 to 0.73). The model was repeated for MSSS score (excluding disease duration)

which yielded similar results and did not reach significance level ( $\beta = 0.52$ ,  $P=0.08$ ,  $95\%CI=-0.06$  to  $1.12$ ) (Table 5.2).

**Table 5.2 Results of linear regression models analysis to calculate the effects of OCB on EDSS and MSSS.**

Dependent Variable	Beta Coefficient (B)	R <sup>2</sup>	P-value
EDSS	0.29	0.24	0.19 <sup>a</sup>
MSSS	0.52	0.13	0.08 <sup>b</sup>

<sup>a</sup> adjusted for; age, sex, DMT, disease duration and initial MS type (RR vs. PP)

<sup>b</sup> adjusted for; age, sex, DMT and initial MS type (RR vs. PP).

### 5.3.2 OCB results over time

In total approximately 20% of patients were OCB negative. A great proportion of the weight in the total percentage was due to higher percentage of negative patients in 1980-1990 period. We investigated the proportion of positive and negative OCB results over the past three decade (1980-2010). In 1980 to 1990, of 48 recorded OCB results, 41% were reported negative while the percentage decreased to 14% in 2001 to 2010 (Table 5.3). The statistical analysis using linear model revealed a significant trend of increasing OCB positivity by 11% over the study period ( $P=<0.001$ ) in our patient cohort.

**Table 5.3 Prevalence of the OCB positive and OCB negative patients at the time of the diagnosis.**

OCB	1980-1990	1991-2000	2001-2010	total
Negative	20	39	26	86
	41.67%	19.6%	14.21%	19.86%
Positive	28	160	157	347
	58.33%	80.40%	85.79%	80.14%

### **5.3.3 Effects of OCB status on time to diagnosis and initial disease type**

OCB-negative patients had longer time to diagnosis than OCB-positive patients. We found that the median (interquartile range) diagnosis delay from the onset of disease was 4.5 (11) years in OCB negative and 2 (6) for OCB positive group (Mann-Whitney U  $p=0.006$ ). We tested the influence of OCB status on clinical course of the disease at its onset. After controlling for sex and age at the onset of the disease having PP or RR MS was independent of OCB status (OR=0.79 95%CI= 0.41 to 1.53).

## **5.4 Discussion**

In the present study, we could not find significant effects of OCBs status on disease progression as measured by EDSS score and MSSS, in both relapse-onset MS and PPMS patients. The direction of our findings was not changed much even after adjusting for the sex, age, disease duration treatment and initial type of MS. This result is consistent with previous studies, which have found that OCBs in the CSF were not associated with either worsening or stability of disability in patients with MS, and OCB negative patients do not have more benign form of MS (Koch et al., 2007; Lourenco et al., 2012; Vilisaar et al., 2005). In contrast, some relatively small studies have found contrary results. A small case-control study reported that OCB-negative patients had a slightly better prognosis, measured as the hazard ratio to reach EDSS milestones of 4 and 6, (Joseph et al., 2009). Zeman et al., in a study with a small sample found that OCB negative patients had a “lower plaque burden” on MRI and a lower median EDSS compared with OCB positive patients (Zeman et al., 1996). A study by Avasarala et al has also concluded that a low number or absence of OCBs in CSF at diagnosis predicts a better prognosis (Avasarala Jr, 2001). There may be reasons for the difference results reported among the studies; different study designs with different study samples size may have contribution to the contradictory results. However, our results are in line with most of the relatively

new studies have used large sample size (Koch et al., 2007; Lourenco et al., 2012; Vilisaar et al., 2005). While the conflicting results were mainly highlighted from studies have had small study sample and some of them has conducted long time ago (Avasarala et al., 2001; Sa et al., 2005; Stendahl-Brodin and Link, 1980; Zeman et al., 1996). Our finding suggests that lack of OCBs in the CSF of suspected cases of MS does not decrease the possibility of the cases to be MS as suggested by some studies.

In our cohort OCB negative result was associated with significant later diagnosis of MS. Although widespread availability of new MRI techniques has made a great improvement in the diagnosis of MS, MS is still considered a disease of exclusion which means often using other diagnosis modalities in case of any diagnosis uncertainty. As the result, LP is often offered to the patients whose diagnosis is not entirely certain which may introduce bias towards patients with more complicated diagnosis. We measured the proportion of our patients with MS testing negative for CSF OCBs to see whether any changes in the percentage of OCB status can be explain by fewer number of ambiguous suspected MS cases recruited for LP. Oligoclonal banding in the CSF not matched in the serum has high sensitivity for MS (Marchetti et al., 1999), however, its specificity for MS range between 62.5 to 82% (Marchetti et al., 1999; Siddiqui et al., 2002). There is evidence suggesting that OCB status in suspected cases of MS is potentially important to exclude differential diagnosis. Therefore, negativity of OCBs in the process of MS diagnosis while other diagnostic measures do not suffice for the diagnosis makes the alternative diagnoses always be in mind.

Although the proportion of MS patients with negative OCB in our cohort was greater (~ 20%) than the 5% reported in the UK in an earlier study (McLean et al., 1990), it adds to the established evidence that the incidence of OCB negative patients meeting the diagnostic criteria for MS is small. Findings from other studies from



different countries used different OCB detection techniques and these varied between studies and countries (see Introduction).

Although our result was greater (~ 20%) than the 5% reported in the UK in an earlier study (McLean et al., 1990), it adds to the established evidence that the incidence of OCB negative patients meeting the diagnostic criteria for MS is small. Findings from other studies from different countries used different OCB detection techniques and these varied between studies and countries (see Introduction).

Our study showed that the OCB positive and OCB negative groups show no differences in the clinical course (relapse-onset MS and PPMS). In contrast, some studies have suggested the association of OCB positivity with PPMS (Fukazawa et al., 1998; Imrell et al., 2006; Kikuchi et al., 2003), Contrary to these studies, and in line with our finding other studies have not found this association, and even they found that the OCB positive patients have developed more likely a relapsing form of disease (Pirttilä and Nurmikko, 1995; Siritho and Freedman, 2009).

In our study the frequency of negativity of OCBs decreased over time. We found a significant trend for positive CSF OCBs overtime. The prevalence of OCB positive was 58.3% in MS patients were diagnosed between 1980 and 1990. This was raised to 83.8% during 2000 to 2010. It is difficult to explain the exact reasons for this change over 30 years, but, some potential confounding issues such as indication for performing a lumbar puncture and the methods used for OCB detection may account for this change.

## **5.5 Conclusion**

In conclusion, we report that positivity or negativity of OCBs in the CSF is not associated with worsening of disability in patients with MS. The absence of OCBs; although not associated with a slower disease progression, is associated with a slightly increased time to reach the diagnosis of MS. The prevalence of the OCB

negative in our MS cohort was approximately 20% which is in line with previously reported studies. We have not reported a significant trend of PPMS patients to have more positive OCBs than the RRMS patients as suggested in some of the previous studies.

**CHAPTER 6 A META-ANALYSIS OF fMRI STUDIES ON  
FATIGUE IN MULTIPLE SCLEROSIS**

## **6.1 Introduction**

In the previous chapters, the concept of fatigue in multiple sclerosis (MS) and the evidence that the wakefulness-promoting drug modafinil may relieve MS fatigue is reviewed. Since the cerebral mechanisms of fatigue in MS are still poorly understood the functional effects of modafinil may be better understood in the context of cerebral functional reorganisation in people with MS who experience fatigue.

The aim of this chapter is to offer an functional MRI (fMRI) insight into cerebral function associated with fatigue in MS patients, using a novel method of meta-analysis applied to current available published data. This is, to our knowledge, the first meta-analysis study of fatigue.

Another element of novelty is the use of a new locally developed method for meta-analysis of fMRI data, which incorporates recently published advances in meta-analysis of fMRI.

A brief overview of MRI and fatigue in MS is presented first.

### **6.1.1 Structural MRI and Fatigue in Multiple Sclerosis**

Fatigue (see also introduction to this thesis) defined as “lack of energy and sense of tiredness not related to muscle weakness” should be differentiated from simple muscle fatigability alone; however some degree of overlap may exist and it is likely that both aspects are important in MS patients. Fatigability means a susceptibility to fatigue.

Structural MRI studies have provided, so far, only inconclusive and somewhat conflicting results. Initial MRI studies did not find any correlation between the degree of subjective fatigue, as measured by clinical scales, lesion load (van der Werf et al., 1998), frequency of enhancing lesions (Mainero et al., 1999) or brain atrophy (Bakshi et al., 1999; Van der Walt et al., 2010). However, other studies reported

fatigue to correlate with white and grey matter volume loss (Tedeschi et al., 2007), confirming the association between a subjective awareness of fatigue and progressive brain atrophy as reported by an eight-year follow up study of relapsing-remitting MS (RRMS) patients with mild clinical disability (Marrie et al., 2005). Together, the conventional MRI data suggest that subjective fatigue may be associated with gray matter (GM) atrophy. This would support a link between fatigue and dysfunction of deep grey matter nuclei (Colombo et al., 2000; Inglese, 2006; Niepel et al., 2006).

Magnetisation transfer and diffusion tensor MRI studies found no difference between MS patients with and without fatigue in the normal- appearing brain tissue involvement, as well as in the severity of GM damage. An association between fatigue and neuroaxonal pathology in MS was supported by the demonstration of abnormal T1 relaxation times in the thalamus of MS patients with fatigue (Niepel et al., 2006) .

Therefore, the question whether fatigue in MS is due to a damage of GM or to a disconnection of specific white matter (WM) pathways secondary to the presence of T2 lesions, or to a combination of the two, is still open. This invites fMRI studies addressing the issue.

### **6.1.2 fMRI and fatigue in Multiple Sclerosis**

fMRI techniques take advantage of the relationship between brain activity and small changes in MRI signal using the blood oxygen level-dependent (BOLD) effect (Logothetis et al., 2001). Upon initiating a task, the neurons in the brain regions involved in that task have an increased metabolic demand. Subsequently, the cerebral blood increases in the local blood capillaries within approximately one millimetre of the neural activity. The increased blood oxygen produces an increase in the MRI signal (BOLD) which is typically only a few percent of the baseline signal, which can make it difficult to detect from background noise (Fox et al., 2011).

In MS patients with fatigue, fMRI studies have consistently shown an abnormal recruitment of several cortical and subcortical networks, supporting a central origin of fatigue in MS (Fox et al., 2011). Those studies showed widespread cortical activation, including that of non-motor cortical areas, during simple motor tasks in all types of MS (Filippi et al., 2002a; Reddy et al., 2000a; Reddy et al., 2000b; Rocca et al., 2002a; Rocca et al., 2002b). An increase in cortical activation has been considered as an adaptive response to weakness due to dysfunction in motor pathways. Also, MS-related fatigue may result from an impairment in cortico-subcortical -thalamus and basal ganglia- interactions involved in motor planning and execution (Filippi et al., 2002a). Some fMRI studies have demonstrated a relationship between cortical activation and fatigue severity (Filippi et al., 2002a). Fatigue severity score (FSS) correlated inversely with right hand finger flexion-extension motor activation in several motor-associated regions: greater fatigue was associated with less relative activation in these regions (Filippi et al., 2002a). Subsequent studies indicate that non-motor functions of the basal ganglia may be involved in fatigue, where greater activation over time in MS patients was observed over repeated sessions of a processing speed task (DeLuca et al., 2008). Performance of a cognitively fatiguing mental task measured with Paced Auditory Serial Addition Test (PASAT) between motor fMRI scans led to an increase in activation to a paced finger task in primarily non-motor areas of MS patients, but a decrease in controls (DeLuca et al., 2008). This observation implies that fatigue may increase the level of neuronal organisation required to perform a particular task (Tartaglia et al., 2008). Furthermore, newly-recruited tissue may not habituate or respond in the same way as older ingrained circuitry in the presence of fatigue. All these data suggest that fatigue in MS is associated with reaching the limit of neuronal compensation (Fox et al., 2011).

In line with these fMRI findings, reduced glucose metabolism in cortical motor and basal ganglia regions in MS patients has been reported using positron emission tomography (PET) (Roelcke et al., 1997). This reduction in cerebral glucose metabolism correlated with the severity of fatigue. The authors suggested that central fatigue in MS is associated with dysfunction of the frontal cortical and basal ganglia connections, most likely resulting from demyelination in the frontal WM.

Clearly, further exploration using fMRI in the area of fatigue in MS is needed. A meta-analysis of current studies using fMRI as a measure of changes associated with fatigue in MS has not been done until now. Such an approach can offer a global perspective of the functional modifications in those patients, and serve as a basis for further study aiming to follow those changes prospectively.

To this date there are no consistent fMRI studies on modafinil effects in MS. As a basis for further study on this matter, a meta-analysis of fMRI data after modafinil administration may be interesting in outlining its effects in a brain without reported macroscopic lesions. These include healthy people, and possibly also drug addicts or patients with narcolepsy.

Finally, meta-analysis of differences between fMRI activations in patients with chronic fatigue syndrome (CFS) and healthy people is performed. Being aware of the complexity and heterogeneity of mechanisms underlying fatigue in different conditions, a meta-analysis of studies involving central nervous system (CNS) patients can offer a different insight in fatigue conditions, thus suggesting a specific and adapted approach for future fMRI studies in MS patients with fatigue.

## **6.2 Methods**

### **6.2.1 Local activation likelihood estimate (LocalALE)**

The activation likelihood estimate (ALE) is a quantitative meta-analysis method that was developed concurrently but independently by Turkeltaub et al. (2002) and Chein

et al. (2002) and probably the most commonly used algorithm for coordinate-based meta-analyses (CBMA) so far. An alternative approach to CBMA is kernel density analysis (KDA) (Wager and Smith, 2003). Both algorithms (KDA and ALE) are based on the idea of describing those locations in the brain where the coordinates reported for a particular paradigm or comparison show an above-chance convergence. The available meta-analysis algorithms employ a false discovery rate (FDR) control (Benjamini and Hochberg, 1995; Genovese et al., 2002) (it is a statistical method used in multiple hypothesis testing to correct for multiple comparisons) or family wise error rate (FWER) control (it is the probability of making one or more false discoveries when performing multiple hypothesis tests in statistics) of the number of voxels falsely declared significant. The results of meta-analysis of fMRI studies are clusters of foci where multiple studies have reported in the same spatial region, indicating functional relevance. The clusters then indicate which brain areas are involved in the specific task. One of the major issues with previously reported CBMA of fMRI studies is type 1 statistical error. This results directly from controlling the type 1 error on a voxel-wise basis, rather than on a cluster-wise basis; clusters forming the results of the CBMA, while voxels only form parts of clusters.

To address this issue Tench and his colleagues have developed a new method of CBMA called Local activation likelihood estimate (LocalALE). The LocalALE method is strongly based on previous methods and it is consider an evolutionary step, rather than a new method. It is a numerical method that finds where studies report in the same anatomical region. The specific novelty of this method is in the clustering and the false cluster discovery rate (FCDR) type 1 error control. FCDR is defined as the expected proportion of falsely rejected clusters among those rejected. The FCDR correction guarantees that in the set of clusters deemed significant for a test of  $\alpha=0.05$ , there are on average no more than 5% of clusters that are false positives.



FCDR is particularly interpretable and relevant to the results of CBMA, controlling the type 1 error by limiting the proportion of clusters that are expected under the null hypothesis. Without FCDR there is considerable risk of false positives with the competing methods. By using this method the false clusters can be better controlled than the widely used ALE method by performing numerical experiments and if there are significant results, they are less likely to be false positives than the competing methods.

The clustering algorithm employed in LocalALE is also more advanced than that used in other CBMA algorithms. LocalALE uses the density of studies reporting activations to detect clusters, while a cluster in the competing methods is simply formed by significant voxels that are connected. As a result LocalALE provides a more complete report of the specific GM structures involved in the task; structures that may be merged into just one cluster by the other methods.

In our study the LocalALE was used to perform meta-analysis. LocalALE is part of NeuROI can be found on:

<http://www.nottingham.ac.uk/scs/divisions/clinicalneurology/software/neuroi.aspx>).

The reported activations (foci) from each of the studies are combined to create the ALE (Eickhoff et al., 2009); the ALE relates to the probability that there is at least one study reporting an activation at a particular location in the GM. To test which parts of the ALE are statistically significant, a randomisation procedure is performed. The ALE is declared significant when multiple studies report activations in similar locations, resulting in clustering of the reported foci. The centroids of each cluster of significant foci are reported, along with Talairach region (Talairach and Tournoux, 1988). These reports indicate areas where multiple studies have reported fMRI activations more often than expected by random chance.

### **6.2.2 Study inclusion**

A search for fMRI studies of fatigue in MS, CFS and modafinil was performed using standard literature databases (Science Direct, Web of Knowledge, and PubMed); keywords; “fMRI” AND “fatigue” AND “multiple sclerosis” or “chronic fatigue syndrome” or “modafinil”. The references of these articles were then assessed for additional studies which could be considered for inclusion, along with the references from review articles of fatigue in MS or CFS. Abstracts were reviewed to select studies involving motor or cognitive fatiguing stimuli. In addition, only studies that reported whole-brain group analysis as coordinates in Talairach (Talairach and Tournoux, 1988) or Montreal Neurological Institute (MNI) reference space (Collins et al., 1994) were considered. Additional filtering of the data excluded single-subject reports from further analysis, along with those reporting only a restricted field of view. The filtering process retained 7 articles in MS patients (totalling 135 MS patients), 7 on modafinil, and 5 articles in CFS, which were carried forward to the analysis.

### **6.2.3 Data extraction**

The data extracted from each article included the authors’ names, date of publication, study population, sample size, mean age, sex ratio, type of fatiguing tasks or stimuli, presence of motor task in the experiment, pre-study reported fatigue, brain activation coordinates and their associated standardised space (Talairach or MNI). Here, we only included foci of activation (except studies with modafinil) because all articles reported activation foci, while the majority of studies did not comment on the presence or absence of deactivation foci. As the encoding of motor tasks takes place primarily in the contralateral hemisphere to the stimulation site the coordinates from left-sided body stimulation were reflected into the opposite hemisphere and analysed along with the coordinates from right-sided body stimulation to maintain homogeneity across all studies as previously carried

out by Lanz et al (2011). Differences in the standardised coordinate space were addressed by converting all reported coordinates to Talairach.

### 6.3 Results

#### 6.3.1 Multiple sclerosis patients with fatigue

The analysis included 4 studies with 59 patients (Table 6.1). All but one experiment analysed in this section included patients with subjective fatigue undergoing motor tasks.

**Table 6.1 Studies providing data on activations in MS patients with fatigue.**

Experiment	Task-induced fatigue (Cognitive / Motor)	Motor task included (Y/N)	Subjective fatigue reported (Y/N)	Subjects
(Specogna et al., 2012)	-	Y	Y	12
(Filippi et al., 2002a)	-	Y	Y	15
(Rocca et al., 2007)	-	Y	Y	12
(Steens et al., 2012)	M	Y	N	20

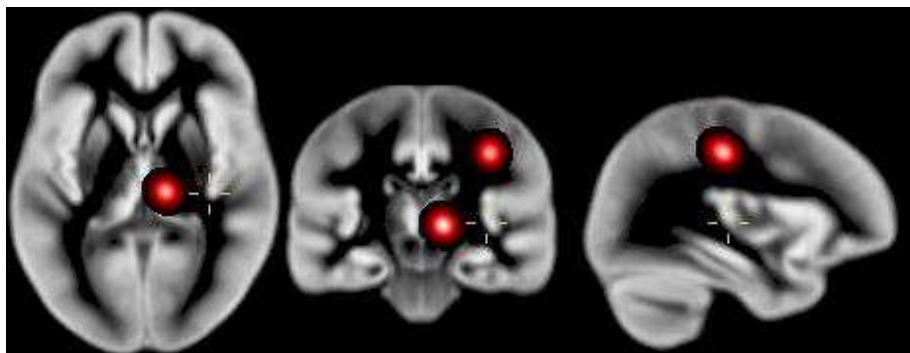

**Figure 6.1 ALE maps for the independent activation likelihood analysis in MS patients with fatigue undergoing motor tasks-significant clusters. ALE maps for the independent activation likelihood analysis in MS patients with fatigue undergoing motor tasks - significant clusters.**

The analysis revealed 2 significant clusters in the left thalamus and left parietal lobe brodmann area (BA40) for a false cluster discovery rate (FCDR) with level 0.05 (Figure 6.1). Adjusting for FCDR at level 7%, another cluster located in ventral anterior cingulate (BA24) was obtained.

### 6.3.2 Multiple sclerosis patients without reported subjective fatigue

The analysis included 3 studies with 36 patients (Table 6.2). All experiments analysed in this section included patients without subjective fatigue undergoing the same motor tasks and experimental procedures as MS patients with fatigue (Table 6.1). None of the patients analysed had reported fatigue and the task did not have a fatiguing component.

Initial analysis using FCDR with level 0.06 elicited 5 clusters, including the following structures on the Talairach map: ipsi- and contralateral inferior Parietal Lobules (BA 40), ipsilateral inferior frontal gyrus (BA 44), contralateral medial frontal gyrus (MFG) (BA6), postcentral gyrus (BA40), transverse temporal gyrus. (BA41), and anterior and posterior cerebellar lobes.

**Table 6.2 Studies providing data on activations in MS patients without fatigue.**

Experiment	Task-induced fatigue (Cognitive / Motor)	Motor task included (Y/N)	Subjective fatigue reported (Y/N)	Subjects
(Specogna et al., 2012)	-	Y	N	12
(Filippi et al., 2002a)	-	Y	N	14
(Rocca et al., 2007)	-	Y	N	10

A further analysis at  $\alpha=0.08$  further added the posterior cingulate gyrus (BA31) and the dentate nucleus (Figure 6.2).

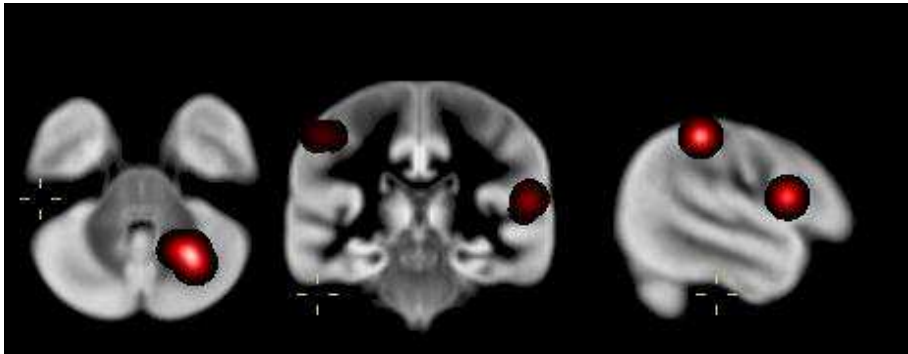

**Figure 6.2 ALE maps for the independent activation likelihood analysis in MS patients without fatigue undergoing motor tasks-significant clusters (FCDR level 0.06).**

### 6.3.3 Multiple sclerosis patients with fatigue vs. MS patients without fatigue

The analysis included data from 3 experiments with 75 patients (Table 6.3), which reported activations being different for MS patients with fatigue vs. patients without fatigue. A unique cluster of activations was obtained (FCDR 7%) in the ipsilateral lentiform nucleus (Putamen) (Figure 6.3). No further loci were obtained for a more permissive FCDR.

**Table 6.3 Studies providing data on activations in MS patients with fatigue vs. patients without fatigue.**

Experiment	Task-induced fatigue (Cognitive / Motor)	Motor task included (Y/N)	Subjects	
			With fatigue	Without fatigue
(Specogna et al., 2012)	M	Y	12	12
(Filippi et al., 2002a)	-	Y	15	14
(Rocca et al., 2007)	-	Y	12	10

### 6.3.4 Healthy controls under same tasks as MS patients with fatigue

This group included 3 studies with 47 healthy controls undergoing same tasks as MS patients (Table 6.4). There was no significant common activation cluster arising from the analysis.

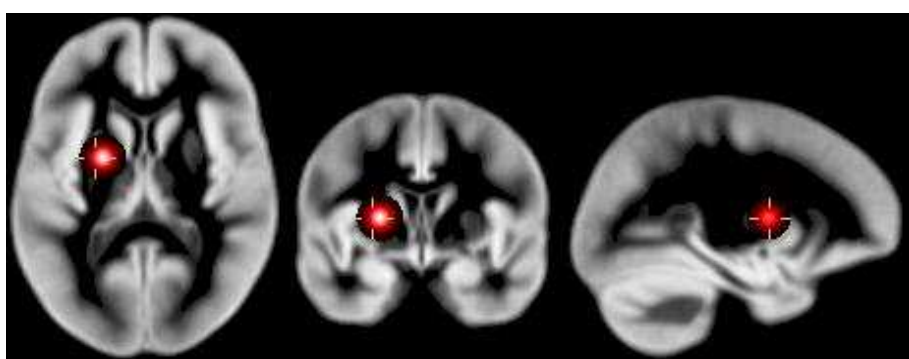

**Figure 6.3 ALE maps for the independent activation likelihood analysis in MS patients with fatigue vs. without fatigue undergoing motor tasks-significant clusters (FCDR level 0.07).**

**Table 6.4 Studies providing data on activation in healthy control.**

Experiment	Task-induced fatigue (Cognitive / Motor)	Motor task included (Y/N)	Subjective fatigue reported (Y/N)	Subjects
(Specogna et al., 2012)	-	Y	-	12
(Filippi et al., 2002a)	-	Y	-	15
(Steens et al., 2012)	M	Y	-	20

### 6.3.5 Brain activations in MS patients (with or without fatigue) vs. healthy controls

This analysis included activations in MS patients with reported subjective fatigue, without reported subjective fatigue but under fatiguing tasks, and without reported fatigue undergoing non-fatiguing tasks; versus healthy controls (Table 6.5). The structures reported as foci for significant activations in MS patients were MFG (BA 6) (FCDR level 5%) and cingulate gyrus (BA 31) (FCDR level 8%) (Figure 6.4).

**Table 6.5 Studies providing data on activations in MS patients (with fatigue/without fatigue) vs. healthy controls.**

Study (author, year)	Type of experiment-induced fatigue (Cognitive=C; Motor = M)	Motor task included in the experiment (Y/N)	Pre-study subjective fatigue (Y/N)	No subjects (patients)	
				With fatigue	Without Fatigue
(Huolman et al., 2011)	C	Y	Y	15	-
(Filippi et al., 2002a)	-	Y	Y	15	14
(DeLuca et al., 2008)	C	Y	N	15	-
(Tartaglia et al., 2008)	C	Y	Y	10	-
(Steens et al., 2012)	M	Y	N	20	-

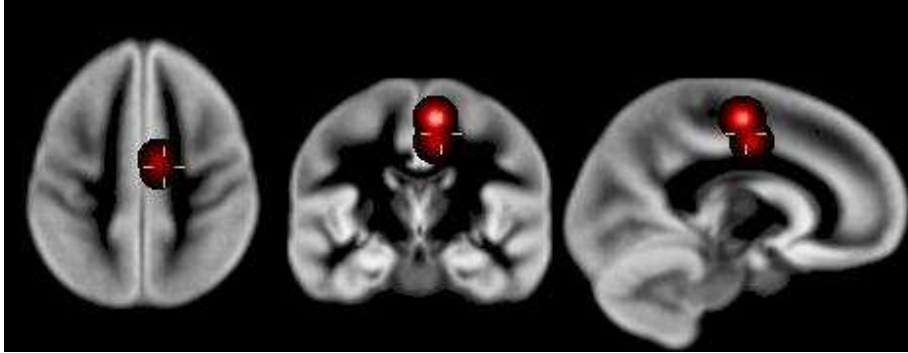

**Figure 6.4 ALE maps for independent activation likelihood analysis in MS patients with fatigue vs. without fatigue undergoing motor tasks-significant clusters.**

### **6.3.6 Comparing ALE in multiple sclerosis patients and healthy controls**

Next data sets previously analysed (MS patients with fatigue; MS patients without fatigue; Healthy controls) were compared. The following comparisons: MS with fatigue vs. healthy controls, MS without fatigue vs. healthy controls, did not elicit any significant activation in favour of any group. However, when comparing MS patients with fatigue with MS patients without fatigue, a significant activation cluster was found in the contralateral precentral gyrus (BA4). While the reverse comparison elicited a significant cluster located in contralateral anterior cerebellar lobe for MS patients without fatigue.

### **6.3.7 Activation clusters related to modafinil exposure in people without conventional MRI-detectable brain morphological lesions (healthy; drug addicts; narcoleptic patients)**

The analysis of modafinil activations included experiments extracted from 7 publications, including 186 subjects (145 healthy persons and 41 cocaine or methamphetamine addicts and narcoleptic subjects). Of those, 4 studies reported no significant differences in activations between patients and controls; however, they were included in analysis (Table 6.6).



There were no significant activations arising from analysis of data on patients, on healthy controls under modafinil, or the comparisons of the two.

When all the data were included in the analysis, activations were found in the left inferior parietal lobule (BA 40), left and right insula (BA13 and 47), anterior cerebellar lobe, claustrum and the right inferior frontal gyrus (BA47) (FCDR level 8%) (Figure 6.5) and (Figure 6.6).

**Figure 6.6 Studies providing data on activations in subjects under modafinil (healthy; drug addicts; narcoleptic patients).**

Experiment	Number of participants			Dose of modafinil	Type of the Task	Deactivation reported Y/N
	Healthy control	Others				
		Number	Type			
(Goudriaan et al., 2012)	16	13	Cocaine dependant	200mg/single dose	Visual	-
(Rasetti et al., 2010)	38			100 mg/7 days	cognitive	Y
(Minzenberg et al., 2008)	21			200mg	-	Y
(Ghahremani et al., 2011)	19	16	Methamphetamine-dependant	200mg/Single dose		
(Joo et al., 2008)	21	-		400mg/2 Single dose 2 week apart	auditory + visual	
(Minzenberg et al., 2011)	18	-		200mg/Single dose	Visual sensorimotor	Y
(Ellis et al., 1999)	12	12	narcolepsy	400mg/ Single dose	Visual+Auditory	

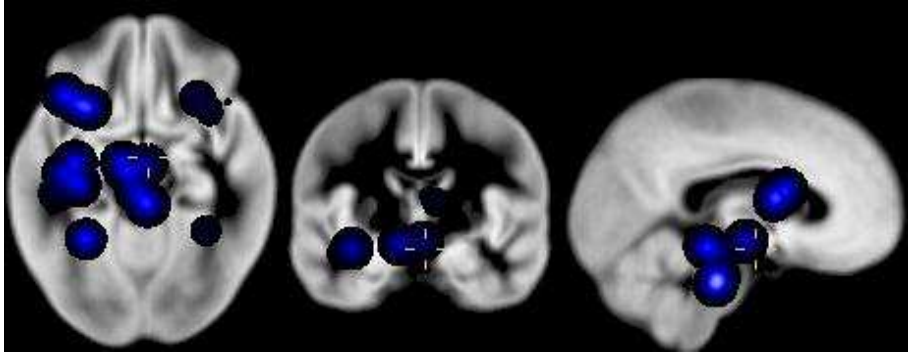

**Figure 6.5** ALE maps for the independent activation likelihood analysis in subjects under modafinil (healthy; drug addicts; narcoleptic patients) -all clusters.

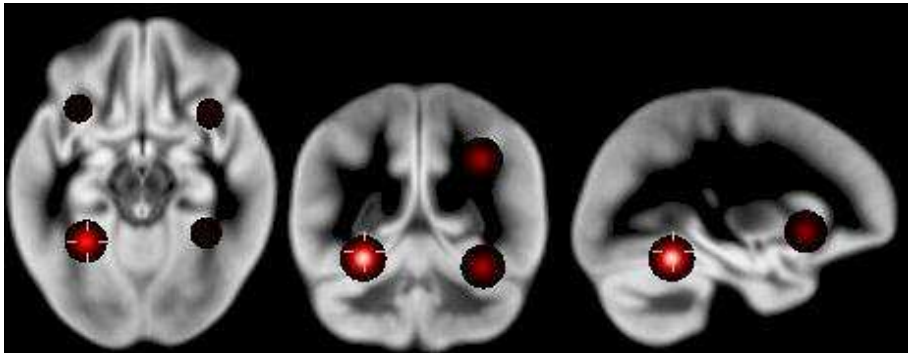

**Figure 6.6** ALE for the independent activation likelihood in subjects under modafinil (healthy; drug addicts; narcoleptic patients) -significant clusters of activations.

We looked for modafinil-related deactivations and retrieved data from 3 experiments (3 publications, 77 subjects). The analysis revealed a trend for 2 regions belonging to the same structure: left anterior cingulate (BA 24 and 32). However, this did not reach significance.

### **6.3.8 Activation or deactivation clusters in people with chronic fatigue syndrome vs. healthy controls**

For a more comprehensive overview of the multiple facets of fatigue, analysis was extended to include a pathological entity characterised by fatigue; CFS. Five experiments, including 60 subjects and deactivations from 2 experiments including 29 subjects, were analysed (Table 6.7). No significant activation or deactivation

resulted after analysis both between CFS patients and healthy controls at baseline or after fatiguing tasks.

**Table 6.7 Studies providing data on activations or deactivations clusters in people with CFS vs. healthy controls.**

Experiment	Type of stimuli, Visual=V/ Auditory= A	Task-induced fatigue Cognitive(C)/ Motor (M)	Deactivation reported (Y/N)	Subjects	
				Healthy controls	CFS
(Caseras et al., 2008)	-	C	Y	13	12
(Tanaka et al., 2006)	V+A	C	N	7	6
(Caseras et al., 2006)	M	C	Y	12	17
(Cook et al., 2007)	-	C	N	11	9
(de Lange et al., 2004)	-	M+C	N	16	16

#### 6.4 Discussion

Fatigue related to MS is an unsolved matter. It is not known whether it is mainly due to damage of GM, a disconnection of specific WM pathways, or to a combination of the two. Moreover, the significance of cortical reorganisation in MS patients with subjective or provoked fatigue is unclear and difficult to interpret. It may represent either a mechanism of compensatory activation or a sign of neural inefficiency. Also, it is not clear if the brain functional changes are a 'marker' of fatigue in MS for example in the cortico- strio-thalamo-cortical loop or a causal mechanism with impact on recovery and performance.

In this study we used a meta-analysis approach to fatigue and MS-related fatigue. In addition, data from fMRI studies using modafinil were analysed, to assess whether they provide indirect information about MS fatigue, and to search for hints on modafinil's sites of action in the brain to explain the role of modafinil as a possible

neuroprotective treatment for MS. To this end, studies using fMRI as measure for brain activity in relation to fatiguing tasks or in patients with reported having fatigue were carefully selected. A novel method for data analysis, designed to improve accuracy, was used. This analysis offers a multi-angle view which might elicit structures that may be important nodes for fatigue circuitry.

fMRI studies in MS usually show widespread functional reorganisation during motor, sensory, and cognitive tasks in different phenotypes and stages of the disease (Filippi et al., 2002a). However, it is not clear if this enrolment of additional brain circuits, which are usually inhibited in healthy subjects when performing the same task represents functional reorganisation or adaptive mechanisms underlying neural disorganisation or disinhibition. The multiple activations obtained in MS non-fatigued patients are partially overlapping with some of the clusters in fatigued patients, suggesting that caution must be exercised in interpreting fMRI data in the latter group as being related to fatigue.

There was no common pattern of activation in healthy controls; which might be expected taking into account the different study designs. Interestingly, from direct ALEs comparisons, while MS patients with fatigue had stronger cortical activations in BA4, non-fatigued MS patients showed cerebellar clusters of activation. We cannot interpret the above mentioned difference between groups (fatigued vs. non-fatigued MS) as being related to the presence or absence of fatigue; they may be explained by difference between patient populations. Comparisons using larger patient groups are needed to study potential difference in activations patterns between two groups.

However, deactivations were not reported constantly in those studies, and MS patients are known to be deficient in maintaining initial activations throughout the motor tasks in comparison to healthy controls. Therefore, a complete picture of

functional changes during motor tasks in MS patients with or without fatigue and healthy controls should include an analysis of brain deactivations as well.

The difference between results in MS patients vs. controls and CFS vs. controls (the latter showing no activation) might suggest that the concept of fatigue cannot be generalised between such different conditions. We might eventually state that a proper study tackling the matter of fatigue in MS should maybe use a behavioural model for fatigue in a brain with multi-tiered structural damage.

#### **6.4.1 Brain activation in MS with fatigue, without fatigue or undergoing fatiguing tasks vs. healthy controls**

The structures reported as loci for significant activations in MS patients with fatigue or undergoing fatiguing tasks were MFG (BA 6) and cingulate gyrus (BA 31). The increased activations in MS patients vs. healthy controls are not an unexpected finding, since most fMRI studies in MS reported this as a characteristic feature of MS-related functional central reorganisation. It was hypothesized that activation in task-relevant areas may reflect compensation, whereas activation in task-irrelevant areas may be linked to inefficiency to overcome increased task demands (Morgen et al., 2007). Current data suggest that fatigue is related to dysfunction in the cortical organization of task performance, but it is not clear whether this association is causal (Filippi et al., 2002a). Fatigue in MS might be related to the impaired cortico-subcortical interaction, responsible for motor planning and execution (Filippi et al., 2002a).

The experiments resulting in the reported activations were relatively homogenous in regard to the type of fatigue: in 3 of 5 of them cognitive fatigue was induced, whereas in all but one subjective fatigue was present. The motor task was part of all experiments irrespective of design, adding an element of homogeneity.

The MFG is a region associated with high-level executive functions and decision-related processes (Fitzgerald et al., 2010), while BA13 is found on dorsal posterior cingulate cortex (DPCC) which is involved in higher order sensory and sensory-motor integration (Pearson et al., 2011). DPCC shows high connectivity to frontoparietal networks involved in cognitive control and has intense communication with attentional systems during periods without a focused task (Leech et al., 2012). The DPCC activation resulting from our analysis arose from the experiment of Tartaglia et al (Tartaglia et al., 2008), in which mental fatigue was induced in MS patients with reported fatigue performing a motor task. Although the DPCC activation might prove increased compensatory networking in the face of demanding tasks, a decreased capacity to optimize recruitment of the motor network with practice (inefficiency), cannot be excluded and may contribute to MS fatigue.

We have considered that fatigue perceived during motor fatiguing tasks in MS patients may be share a common ground with subjective reported fatigue. Recently it was shown that correlates between perceived fatigue during maximal task and muscle activity were found for hand muscles, despite the lack of correlation with parameters associated with the integrity of the corticospinal tract (Steens et al., 2012). This is of particular importance since all studies included in this meta-analysis used hand motor tasks either as fatigue inducing task or activation task in subjects with reported fatigue.

#### **6.4.2 MS patients with fatigue: role of thalamo-striate loop**

In MS patients with reported fatigue at the start of the study, the contralateral thalamus (pulvinar) is the region resulting from our analysis as the most consistently activated. However, some other areas showed significant activations under less conservative parameters: medial and precentral gyri in the frontal lobes (BA 4); postcentral gyrus (parietal lobe, BA3); ventral cingulate gyrus (BA 24) and ipsilateral lentiform nucleus (Putamen).

Interestingly, both thalamus and parietal cortex atrophy have been associated with fatigue in RRMS (Calabrese et al., 2010). Moreover, the posterior parietal cortex was shown to be one of the best predictors of the MFIS cognitive domain, suggesting the major role of the posterior attentional system in determining cognitive fatigue in RRMS (Calabrese et al., 2010).

The thalamus is an important relay station of the complex re-entrant circuitry that links the motor and the prefrontal cortices to the basal ganglia and which is part of the feedback loops of the limbic system able to modulate the cortical motor output (Chaudhuri and Behan, 2000). Several functional imaging studies suggested that fatigue in MS could result from altered connection between cortical and sub-cortical areas involved in motor planning (DeLuca et al., 2008; Filippi et al., 2002b). Moreover, it was suggested that 'interruption of the associated loop of striatocortical fibres or a net change in the thalamic activity suppressing cortical activation via the striato-thalamo-cortical loop will predispose to the symptoms of central fatigue' (Chaudhuri and Behan, 2000). A reduction in the dopaminergic drive to the pallido-thalamo-cortical loop might suppress frontal activation (a loss of motivational influence of the striato-thalamic input to the frontal lobe - prefrontal, orbitofrontal and cingulate regions) (Chaudhuri and Behan, 2004). This may result from the anatomical loss of structures of both WM and GM.

Of note, the subjects analysed in this group did not undergo cognitive tasks. This may explain some difference with concomitant activations seen in fMRI studies using this type of task (DeLuca et al., 2008). Nevertheless, activations in frontal areas, cingulate gyrus and, most importantly, thalamus, suggest a common network in connection with fatigue in MS, independently of the trigger used to elicit it, with the thalamus as key bidirectional relay centre.

Activation of the ipsilateral lentiform nucleus (putamen) is the element differentiating patients with reported fatigue from those without. Basal ganglia are involved in the

higher order, cognitive aspects of motor control and these neurons also influence many other functions through their extensive connections with the association cortex and limbic structures. The association of central fatigue with basal ganglia diseases, whether structural, metabolic or chemical has been suggested (Chaudhuri and Behan, 2000). Therefore, our data support the concept of central fatigue associated to the dysfunction of the cortico- strio-thalamo-cortical loop.

Based on the results of this study and the functional studies in the literature, central fatigue in MS might involve a multi-tiered brain functional disorganisation. Therefore, a drug that could act at more than one level in this complex dysfunction may offer the rationale for a functional interference with the key nodes involved in central fatigue mechanisms in MS. Modafinil may represent an ideal candidate for this purpose.

#### **6.4.3 Modafinil-related activations and deactivations: possible implications for fatigue in Multiple Sclerosis**

The analysis showed multiple brain activations under modafinil in a group of healthy controls and patients with narcolepsy or drug-addicts. Although the heterogeneity of subjects and experimental designs of studies included in the analysis might be a point of criticism, a common feature of the analysed group is the lack of known brain morphological lesions. Although the molecular effects of modafinil may be nonspecific, it is accepted that modafinil potentiates both dopamine (DA) and norepinephrine (NE) transmission through the inhibition of their transporter enzymes (Minzenberg et al., 2008; Volkow et al., 2009). Therefore, it is likely that the neurophysiologic effects of modafinil on the brain structures such as prefrontal cortex and anterior cingulate, both of which are rich in catecholaminergic projections, during tasks involving executive cognition are most likely driven by DA, NE or both.



Recent animal studies suggest that NE enhances 'signals' through postsynaptic adrenoceptors on prefrontal cortex dendritic spines, whereas DA decreases 'noise' through modest levels of D1 receptor stimulation (Brennan and Arnsten, 2008). Drugs that modulate DA and NE system and enhance catecholamine transmission have been shown to increase efficiency of information processing in prefrontal circuits as consistently shown through functional neuroimaging studies (Apud et al., 2007; Cools and Robbins, 2004).

Importantly, recent data suggest that modafinil might act efficiently only in subjects having a certain degree of dysregulation in the targeted circuitry (see also introduction chapter of the thesis). This is consistent with findings from a wider range of cognitive functioning. Modafinil can improve response inhibition only in alcohol-dependent patients that show poor initial response inhibition while making it worse in healthy controls (Schmaal et al., 2012), and was found to be effective only in healthy individuals and patients with schizophrenia and methamphetamine dependence who show poor baseline performance on working memory (Kalechstein et al., 2010; Spence et al., 2005), cognitive control and visual attention tasks (Finke et al., 2010; Hunter et al., 2006). This is in line with an inverted U-shaped relationship between catecholamine neurotransmitter levels and cognitive performance (Levy, 2009) implying that there is an optimum for catecholamine neurotransmitter levels to efficiently execute cognitive tasks (Schmaal et al., 2012). The degree of fatigue in MS is related at least in part to cognitive parameters (Andreasen et al., 2010). MS patients with more pronounced 'cognitive fatigue' might be a potential group of responders for modafinil, and further studies might tackle on this issue.

In our analysis, thalamus was significantly activated in MS patients with fatigue. Thalamus activation as identified by fMRI may represent either excitatory or inhibitory neural activity. In alcohol-dependent subjects with poor initial response

inhibition, modafinil positive effects were associated with thalamic activation and decreased thalamo-cortical output. These and other data suggest that modafinil exerts its effect directly on the thalamus, resulting in subsequent changes in functional connections of the thalamus with other brain regions (Joo et al., 2008; Minzenberg and Carter, 2007). The thalamus is a key node for dopamine in the brain (Govindaiah et al., 2010; Sanchez-Gonzalez et al., 2005). This might be relevant for fatigue in MS and deserves further study.

Concluding, although the mechanisms by which modafinil may impact fatigue in MS are still unclear, an interference with the thalamo-cortical loop is possible. Modafinil might have multi-level actions which could translate in improvement in fatigue (especially fatigue having a cognitive component), and this deserve further study with appropriate experimental design

## **6.5 Conclusions**

In summary, our analysis suggests the following:

- Thalamus and striate are central and relevant nodes for the pathogenesis of fatigue in MS.
- fMRI studies in MS-related fatigue should take into account not only the extreme variability of MS brains, but also the common functional pattern of activation of a sick brain, which always shows increased activations and recruitment in response to damage; it is the time and phase sequence of those activations, as well the failure to appropriately deactivate when the task is formed which might be relevant to the occurrence of fatigue;
- The present meta-analysis study suggests the interference of modafinil with the thalamo-cortical loop is possible.
- Further study with more complex experimental paradigms is needed in order to shed light on MS-related fatigue.

## **CHAPTER 7 GENERAL SUMMARY AND CONCLUSIONS**

## 7.1 General summary

The main objective of this thesis was to gain greater insight into the potential neuroprotective effects of modafinil in multiple sclerosis (MS). In order to study this, we examined the effects of modafinil on several different outcomes including the expanded disability status scale (EDSS), fatigue and the autonomic nervous system (ANS) in humans and clinical scores of severity of the disease and pathological findings, in experimental autoimmune encephalomyelitis (EAE).

The meta-analysis study presented in chapter six used a new locally developed functional MRI (fMRI) meta-analysis method. This study may provide a better view into the central mechanism of the fatigue in general and in MS in particular. Evidence from previous studies suggests the beneficial role of modafinil in MS fatigue. Since the cerebral mechanisms of fatigue in MS are still not clear, the functional effects of modafinil may be better understood in the context of cerebral functional reorganization in people with MS who experience fatigue. Therefore, the study addressed what areas could be activated by modafinil treatment and if whether these areas and areas affected by MS fatigue overlap.

Also, as a future work we have designed a protocol for a randomised, assessor-blind, non-treatment controlled, parallel group design exploratory trial (see appendix 10 for detail).

We also included a study of the relation between oligoclonal band (OCB) positivity and disease progression in MS. Although somewhat separated from the main focus of this thesis, the study relates to the evolution of disability in MS, which is the focus of a significant part of the thesis, and although not related to modafinil, it has relevance to the progression of MS. Moreover, I collected the data on OCB status and EDSS progression of patients as part of the retrospective assessment of MS patients in the database that was used for evaluation of modafinil effects, and thus I

thought it may be appropriate to incorporate this information as part of a separate, if not tightly related, information.

MS is a challenging disease to treat. Traditional immunosuppressants such as cyclophosphamide and azathioprine have been used in MS for some time, showing a variable degree of benefit (La Mantia et al., 2007; Yudkin et al., 1991). However, the risk of serious side effects, and the emergence of new immunomodulatory drugs, has limited their use.

Disease modifying therapies (DMT) have been proved to reduce the frequency and severity of relapses in MS, as consequences, minimise disability and reduce disability progression without significant immunosuppressive effects. However, they may partially confer neuroprotection. The promising new drugs currently in development such as monoclonal antibodies, and oral agents for relapsing and progressive forms of the disease (see chapter one). Neuroprotective agents that impact directly on neuronal well-being would be desirable, particularly since axonal loss and neuronal injury have been shown to be the histological correlates of neurological disability. Part from introductory chapter was specified for review of EAE. EAE is the most commonly used experimental model for MS. Many of the drugs that are in current or imminent use in MS have been developed, tested or validated on the basis of EAE studies. Therefore, in an attempt to test the possible neuroprotective effect of modafinil in MS reflected by EAE we conducted a study and detailed this in this thesis (see chapter four).

The novelty of this thesis was that previously modafinil has been investigated exclusively as an anti-fatigue treatment for MS, but its potential for neuroprotection, as shown in other, non-MS studies, had not been investigated.

In the initial study in this thesis we evaluated retrospectively the effects of continuous three or more years treatment with modafinil in MS patients compared with a matched group of MS patients who have no exposure to modafinil. We found

that the MS patients who had no exposure to modafinil experienced significantly greater increases in EDSS compared to patients with MS who received modafinil for three and more years without interruption. This was seen in both relapsing-remitting and progressive types of MS. Although retrospective, to the best of our knowledge this is the first study that examines the potential neuroprotective effect of modafinil in MS reflected by measurement of EDSS scores. These findings were in line with previous studies in animal models that have revealed that modafinil can be a neuroprotective agent for neurodegenerative disorders (Jenner et al., 2000; van Vliet et al., 2006; Xiao et al., 2004).

.In the second experimental study, we wanted to validate the results of the retrospective study in the experimental model of MS, EAE. The effect of modafinil on the severity of disease in EAE has not been previously assessed. The results of this experiment suggested a significant effect of modafinil in reducing the clinical severity of EAE. This was more obvious in animals treated with the higher dose (100mg/kg) of modafinil compared with low dose (50mg/kg) and compared to negative control group. Histopathology including staining for axons, myelin, inflammatory infiltrates, and proteomics are underway, and will represent the subject of future investigation but are not part of this thesis. Nevertheless, as modafinil was administered after the mice developed clinical signs and the modafinil treated mice generally failed to progress, it can be argued that the effect was at least in part, neuroprotective.

The study detailed in chapter 4 was aiming to begin to understand which mechanisms of action of modafinil may explain its neuroprotective effect. We explored the relationship between the antifatigue and alerting/sympathomimetic effects of modafinil. With some re-evaluation of previously collected data and reanalysing the data, we examined whether there is any difference between MS patients with fatigue, MS patients without fatigue, and healthy controls on measures of alertness and autonomic function. We also examined the hypothesis that MS

patients with fatigue may be more sensitive to the alerting and sympathetic activating effects of modafinil than MS patients without fatigue or healthy subjects. Although its mechanism is yet to be clarified, evidence supports an interaction with the arousal network. In this study a number of subjective and objective measures of alertness measures were utilised to explore more objectively the role of modafinil. It was demonstrated that in MS patients with fatigue, there was a significant improvement with modafinil, as compared to placebo. This supports a role of modafinil in MS-related fatigue management potentially through its effect on the arousal network.

The reason the OCB study is included in the thesis is discussed above. Previous studies suggested that OCB negative MS carried a relatively more favourable long term prognosis, with milder disability (Moulin et al., 1983; Roxburgh et al., 2005; Tan et al., 1997; Zeman et al., 1996). However, these studies were conducted on relatively small patient cohorts. In chapter five, we evaluated the prevalence of OCBs negative CSF in our MS population and the impact on disease progression reflected by EDSS and MS severity score (MSSS) measures. The findings suggest that OCBs has no impact on disease progression in MS patients and the negative OCB patients do not experience more benign disease.

The primary aim of the meta-analysis study presented in chapter 6 was to obtain an insight into cerebral functional phenomena associated with fatigue in MS patients, using a novel method of meta-analysis developed by our group (Dr Christopher Tench), applied to current available published data. The published data on modafinil using fMRI have also been analysed in this study aiming to observe if modafinil activity might provide indirect information about MS fatigue, and look for clues on the sites of action of modafinil in the brain, to see if these specific sites can add further evidence regarding its suggested neuroprotection in MS patients. The results of this meta-analysis revealed that the thalamus was significantly activated in

MS patients with fatigue. Although the mechanisms by which modafinil may impact on fatigue in MS are still unclear, the results could suggest that an interference with the thalamo-cortical loop is a possible mechanism. Evidence from our study has suggested that modafinil might have multi-level actions in the brain, especially it may interfere with thalamo-cortical loop which could translate into improvement in disability progression in MS and in turn may reflect its potential neuroprotective effect. This promising finding calls for further study with appropriate experimental design.

## **7.2 Conclusion**

The objectives of these studies were relatively broad and for that the thesis may be subject to criticism as being unfocused. However, these studies (except perhaps one, see below) are all linked through their aim of directly or indirectly shedding light on as yet unelucidated aspects of modafinil and fatigue in MS. Our retrospective study of modafinil in MS suggests a reduction in EDSS progression and is consistent with evidence of possible neuroprotective action demonstrated in other neurodegenerative conditions. However, the retrospective study did not allow deep insights into the mechanism of the neuroprotective action. We hypothesized that clues to these mechanisms would be provided by a better knowledge of the wakefulness promoting and anti-fatigue mechanisms of modafinil. However, these are themselves far from being clarified. In view of this, we re-analysed data generated from a study looking primarily at whether the pupillographic sleepiness test and pupillary unrest index could be used as a surrogate measure of fatigue in MS, and looked at the relationship between fatigue and arousal in MS and the effect of modafinil. The arousal pathways and neurotransmitters involved are better known, and therefore we can learn about neurotransmitter and circuit targets that modafinil can act on, and build plausible models about the potential sites for neuroprotective actions in MS.



Along these lines, we took advantage of a novel meta-analysis method developed in-house to investigate sites involved in MS-related fatigue, and fatigue in chronic fatigue syndrome (CFS), to obtain further information on plausible sites, circuits and neurotransmitters involved in the modafinil neuroprotective effects.

In addition, we showed a positive (likely at least in part neuroprotective) effect of modafinil on EAE. The role of these studies was to provide preliminary results on whether modafinil can modulate EAE. The mechanisms are to be elucidated in future studies. These studies will benefit from results in this thesis, as we will try to determine whether results on neuroprotection are mediated by the same neurotransmitters and circuits as results on arousal/wakefulness and against fatigue. For example, it has been shown that modafinil wakefulness effects are abrogated in Dopamine receptor 1 (DR1) knockout mice, and we will in future assess the neuroprotective effects on EAE in DR1 knockout mice or in the presence of a DR1 antagonist. We have demonstrated a cortico-striato-thalamo-cortical circuit to be involved in fatigue (and, likely, the effects of modafinil) through the fMRI meta-analysis, and have obtained (and will obtain in further experiments) microdissected samples from these regions in EAE mice treated or not treated with modafinil, and subject them to proteomic analysis to obtain hints regarding the mechanisms of action.

The one exception referred to above is the OCB study which is somewhat different from the others and is not related to modafinil. We included this study because the retrospective EDSS data were collected during the retrospective modafinil study, and OCB positivity has been reported to be a factor that determines the disease course. Therefore, we selected to include this study, being another aspect relevant to MS progression, which may be important to future studies of neuroprotective trials. For example, a proportion of patients with positive OCB with PPMS have a better response to B cell depleting therapies.

## **7.3 Limitations and Strengths of the studies**

### **7.3.1 Limitation of the studies**

Although the studies included in this thesis were carefully prepared, I am still aware of their limitations and shortcomings.

We have discussed the limitation of retrospective studies in chapter 2.

Although the sample size in our study was relatively large, retrospective studies may need larger sample sizes for appropriate outcomes. It has become increasingly important both in the clinical setting and in therapeutic trials to measure disability levels repeatedly in order to assess progression of disability. Measuring EDSS has some limitations, which are well documented. Importantly, it is biased towards locomotor function, is insensitive to change at certain levels and has only moderate inter- and intra-rater reliability. An increase of 1 point if the baseline EDSS is  $\leq 5.0$  and increase of 0.5 point if the baseline EDSS is  $\geq 5.5$ , are the most commonly used measures in assessing disability progression.

In the third study the sample size was pre-established. We encountered difficulties in finding MS patients without fatigue, as well as patients with fatigue untreated with anti-fatigue drugs or other drugs that can influence fatigue, and therefore, although the results are “clean” in that they represent the effects of modafinil without confounding factors, they may not be representative of a large number of MS patients.

Limitations regarding our meta-analysis study are that the results may be hampered by heterogeneity, which can be explained by the multiple differences between studies with regard to the study design, analytic procedures of fatigue measurement, and confounding factors and adjustment for confounders.

### **7.3.2 Strengths of the studies**

The studies that have been presented in this thesis; the potential neuroprotective effects of modafinil in MS; the antifatigue and alerting effects of modafinil, the effect of modafinil on severity progression in EAE, the role of OCBs in the CSF of MS patients on clinical aspects of the disease and finally, the brain areas affected by fatigue in general and in particular MS-related fatigue also the brain areas activate by modafinil treatment in vary of pathological and non-pathological conditions, taken as a whole, they are addressing significant issues. These studies have a number of novel findings which will have improved the quality of the information. These include the finding of possible neuroprotection effects of modafinil in MS and animal model of MS. Previous studies have assessed the role of modafinil as an antifatigue agent in MS. Our findings have suggested that MS patients with fatigue have an arousal deficit and that modafinil can improve it.

To the best of our knowledge the meta-analysis study presented in chapter six is the first meta-analytical approach on the fMRI in fatigue. Moreover, this is one of the first studies to apply the locally developed new method for meta-analysis of fMRI data, which incorporates recently published advances in meta-analysis of fMRI and new elements in terms of concept and statistical processing, which is another element with novelty of this study.

### **7.4 Clinical implementation and importance of the findings**

Our retrospective study in MS, complemented by the preliminary results in EAE, suggests a neuroprotective effect of modafinil in inflammatory demyelination. An ideal neuroprotective compound will need to be potent, have a long-lasting effect and should be devoid of uncontrollable side-effects or risk of major toxicity (Drukarch and Van Muiswinkel 2001). Modafinil in part matches this profile as its use is considered safe without tolerance effects based on daily use in narcolepsy patients (Bastuji and Jouvet 1988). Moreover, generally modafinil elicits no

uncontrollable side-effects in humans (Robertson and Hellriegel 2003), although there have been issues related to hypertension, myocardial infarction and severe rashes. Taken together, the positive actions of modafinil on disease progression in MS and EAE are indicating that clinical application for its neuroprotection is possible. Therefore, testing for clinical efficacy of its therapeutic and neuroprotective actions in MS would be a logical and relatively easy second step as modafinil is already a marketed drug.

Our studies have also identified regions affected by fatigue in MS, and have explored whether these regions are targets for modafinil's pharmacological actions. These studies will help elucidate whether the wake-promoting/antifatigue and neuroprotective actions of modafinil act on the same pathways and neurotransmitter systems, which may enhance knowledge of both fatigue and pharmacological neuroprotection for future therapies in MS.

### **7.5 Difficulties in clinical implication of modafinil**

Despite the positive findings regarding modafinil, and its neuroprotective potential in the experimental animal model, the prospect of its clinical application in the near future is uncertain. The reason for this is that clinical neuroprotection is much more difficult to establish. The discrepancy between experimental outcomes and clinical use may be a result of the shortcomings of EAE to completely reproduce the complex clinical MS pathogenesis. However, the results of the retrospective study are encouraging and justify a prospective study (see below).

However, despite the above described hurdles in clinical application of neuroprotective treatment in general and modafinil in particular, neuroprotection is still the best perspective in the treatment of MS patients.

## **7.6 Recommendations for future research**

A large randomized controlled study will be necessary to further evaluate these results and conclusion of these studies on potential neuroprotective effects of modafinil in MS. Additional development of study design and application of clinical, laboratory and imaging techniques may also be appropriate. Furthermore, more knowledge about modafinil's mechanisms of action would benefit its application. We designed a protocol for this kind of study (Appendix 10). The study is a randomised, assessor-blind, non-treatment controlled, parallel group design exploratory phase II trial. This design means that it is possible to test and examine the hypothesis that modafinil reduces disability progression in progressive MS forms. One of the advantages of this protocol is the relatively long study period. There has been no previous prospective study of modafinil for EDSS progression as a primary outcome measure. I have contributed to the design of this study, which is being funded by the J P Moulton Foundation and TEVA UK. Due to regulatory delays caused by the takeover of Cephalon, the manufacturer of modafinil, by TEVA, the study is not part of my thesis, but will answer important questions for future research into the mechanisms of action and efficacy of modafinil in MS.

## **BIBLIOGRAPHY**

Aaronson, L. S., Teel, C. S., Cassmeyer, V., Neuberger, G. B., Pallikkathayil, L., Pierce, J., Press, A. N., Williams, P. D., Wingate, A., 1999. Defining and Measuring Fatigue. *Journal of Nursing Scholarship* 31, 45-50.

Abduljawad, K. A. J., Langley, R. W., Bradshaw, C. M., Szabadi, E., 1997. Effects of clonidine and diazepam on the acoustic startle response and on its inhibition by 'prepulses' in man. *Journal of Psychopharmacology* 11, 29-34.

Abreu, S. L., 1982. Suppression of experimental allergic encephalomyelitis by interferon. *Immunological Communications* 11, 1-7.

Adler, C. H., Caviness, J. N., Hentz, J. G., Lind, M., Tiede, J., 2003. Randomized trial of modafinil for treating subjective daytime sleepiness in patients with Parkinson's disease. *Movement Disorders* 18, 287-293.

Agnello, D., Bigini, P., Villa, P., Mennini, T., Cerami, A., Brines, M. L., Ghezzi, P., 2002. Erythropoietin exerts an anti-inflammatory effect on the CNS in a model of experimental autoimmune encephalomyelitis. *Brain Research* 952, 128-134.

Akaoka, H., Roussel, B., Lin, J. S., Chouvet, G., Jouvet, M., 1991. Effect of modafinil and amphetamine on the rat catecholaminergic neuron activity. *Neuroscience Letters* 123, 20-22.

Amiri, S., Mohammadi, M.-R., Mohammadi, M., Nouroozinejad, G.-H., Kahbazi, M., Akhondzadeh, S., 2008. Modafinil as a treatment for Attention-Deficit/Hyperactivity Disorder in children and adolescents: A double blind, randomized clinical trial. *Progress in Neuro-Psychopharmacology and Biological Psychiatry* 32, 145-149.

Anderson, A. L., Reid, M. S., Li, S. H., Holmes, T., Shemanski, L., Slee, A., Smith, E. V., Kahn, R., Chiang, N., Vocci, F., Ciraulo, D., Dackis, C., Roache, J. D., Salloum, I. M., Somoza, E., Urschel Iii, H. C., Elkashef, A. M., 2009. Modafinil for the treatment of cocaine dependence. *Drug and Alcohol Dependence* 104, 133-139.

Andreasen, A. K., Spliid, P. E., Andersen, H., Jakobsen, J., 2010. Fatigue and processing speed are related in multiple sclerosis. *European Journal of Neurology* 17, 212-218.

Annunziata, P., Giorgio, A., De Santi, L., Zipoli, V., Portaccio, E., Amato, M. P., Clerici, R., Scarpini, E., Moscato, G., Iudice, A., Vacca, G., Orefice, G., Morra, V. B., Maimone, D., 2006. Absence of cerebrospinal fluid oligoclonal bands is associated with delayed disability progression in relapsing-remitting MS patients treated with interferon-beta. *Journal of the Neurological Sciences* 244, 97-102.

Antonelli, T., Ferraro, L., Hillion, J., Tomasini, M. C., Rambert, F. A., Fuxe, K., 1998. Modafinil prevents glutamate cytotoxicity in cultured cortical neurons. *NeuroReport* 9, 4209-4213.

Apud, J. A., Mattay, V., Chen, J., Kolachana, B. S., Callicott, J. H., Rasetti, R., Alce, G., Iudicello, J. E., Akbar, N., Egan, M. F., Goldberg, T. E., Weinberger, D. R., 2007. Tolcapone improves cognition and cortical information processing in normal human subjects. *Neuropsychopharmacology* 32, 1011-1020.

Arnold, L. M., 2008. Understanding fatigue in major depressive disorder and other medical disorders. *Psychosomatics*. 49, 185-190.

Arnon, R., Aharoni, R., 2004. Mechanism of action of glatiramer acetate in multiple sclerosis and its potential for the development of new applications. *Proceedings of the National Academy of Sciences of the United States of America* 101, 14593-14598.

Attarian, H. P., Brown, K. M., Duntley, S. P., Carter, J. D., Cross, A. H., 2004. The Relationship of Sleep Disturbances and Fatigue in Multiple Sclerosis. *Archives of Neurology* 61, 525-528.

- Avasarala, J., Cross, A. H., Trotter, J. L., 2001. Oligoclonal band number as a marker for prognosis in multiple sclerosis. *Archives of Neurology* 58, 2044-2045.
- Avasarala Jr, C. A. H. T. J. L., 2001. OLigoclonal band number as a marker for prognosis in multiple sclerosis. *Archives of Neurology* 58, 2044-2045.
- Bai, L., Lennon, D. P., Eaton, V., Maier, K., Caplan, A. I., Miller, S. D., Miller, R. H., 2009. Human bone marrow-derived mesenchymal stem cells induce Th2-polarized immune response and promote endogenous repair in animal models of multiple sclerosis. *GLIA* 57, 1192-1203.
- Bakshi, R., 2003. Fatigue associated with multiple sclerosis: diagnosis, impact and management. *Multiple Sclerosis* 9, 219–227.
- Bakshi, R., Miletich, R. S., Henschel, K., Shaikh, Z. A., Janardhan, V., Wasay, M., Stengel, L. M., Ekes, R., Kinkel, P. R., 1999. Fatigue in multiple sclerosis: Cross-sectional correlation with brain MRI findings in 71 patients. *Neurology* 53, 1151.
- Bakshi, R., Shaikh, Z. A., Miletich, R. S., Czarnecki, D., Dmochowski, J., Henschel, K., Janardhan, V., Dubey, N., Kinkel, P. R., 2000. Fatigue in multiple sclerosis and its relationship to depression and neurologic disability. *Multiple Sclerosis* 6, 181-185.
- Ballon, J., Feife, I. D., 2006. A systematic review of modafinil: potential clinical uses and mechanisms of action. *J Clin Psychiatry*. 2006; 67: 554–566. *Journal of Clinical Psychiatry*. 67, 554–566.
- Bar-Or, A., Calabresi, P. A. J., Arnold, D., Markowitz, C., Shafer, S., Kasper, L. H., Waubant, E., Gazda, S., Fox, R. J., Panzara, M., Sarkar, N., Agarwal, S., Smith, C. H., 2008. Rituximab in relapsing-remitting multiple sclerosis: A 72-week, open-label, phase I trial. *Annals of Neurology* 63, 395-400.
- Barnett, M. H., Prineas, J. W., 2004. Relapsing and remitting multiple sclerosis: Pathology of the newly forming lesion. *Annals of Neurology* 55, 458-468.
- Bartoš, A., Fialová, L., Soukupová, J., Kukul, J., Malbohan, I., Piřha, J., 2007. Elevated intrathecal antibodies against the medium neurofilament subunit in multiple sclerosis. *Journal of Neurology* 254, 20-25.
- Baxter, A. G., 2007. The origin and application of experimental autoimmune encephalomyelitis. *Nature Reviews Immunology* 7, 904-912.
- Bechtold, D. A., Kapoor, R., Smith, K. J., 2004. Axonal Protection Using Flecainide in Experimental Autoimmune Encephalomyelitis. *Annals of Neurology* 55, 607-616.
- Bechtold, D. A., Miller, S. J., Dawson, A. C., Sun, Y., Kapoor, R., Berry, D., Smith, K. J., 2006. Axonal protection achieved in a model of multiple sclerosis using lamotrigine. *Journal of Neurology* 253, 1542-1551.
- Beck, A. T., Steer, R. A., Ball, R., Ranieri, W. F., 1996. Comparison of Beck Depression Inventories-IA and-II in Psychiatric Outpatients. *Journal of Personality Assessment* 67, 588-597.
- Becker, P., Schwartz, J. L., Feldman, N., Hughes, R., 2004. Effect of modafinil on fatigue, mood, and health-related quality of life in patients with narcolepsy. *Psychopharmacology* 171, 133-139.
- Beckett, G., Walker, S. W., Rae, P., Ashby, P., 2010. *Lecture Notes: Clinical Biochemistry*. Blackwell Publishing.



- Bednarova, J., Stourac, P., Adam, P., 2005. Relevance of immunological variables in neuroborreliosis and multiple sclerosis. *Acta Neurologica Scandinavica* 112, 97-102.
- Ben-Nun, A., Wekerle, H., Cohen, I. R., 1981. The rapid isolation of clonable antigen-specific T lymphocyte lines capable of mediating autoimmune encephalomyelitis. *European Journal of Immunology* 11, 195-199.
- Benjamini, Y., Hochberg, Y., 1995. Controlling the false discovery rate: a practical and powerful approach to multiple testing. *Journal of the Royal Statistical Society, Series B (Methodological)* 57, 289-300.
- Benwell, N., Mastaglia, F., Thickbroom, G., 2007. Changes in the functional MR signal in motor and non-motor areas during intermittent fatiguing hand exercise. *Experimental Brain Research* 182, 93-97.
- Bibani, R. H., Tench, C. R., George, J., Manouchehrinia, A., Palace, J., Constantinescu, C. S., 2012. Reduced EDSS progression in multiple sclerosis patients treated with modafinil for three years or more compared to matched untreated subjects. *Multiple Sclerosis and Related Disorders* 1, 131-135.
- Biederman, J., Swanson, J. M., Wigal, S. B., Boellner, S. W., Earl, C. Q., Lopez, F. A., 2006. A comparison of once-daily and divided doses of modafinil in children with attention-deficit/hyperactivity disorder: a randomized, double-blind, and placebo-controlled study. *Journal of Clinical Psychiatry* 67, 727-735.
- Biederman, J., Swanson, J. M., Wigal, S. B., Kratochvil, C. J., Boellner, S. W., Earl, C. Q., 2005. Efficacy and safety of modafinil film-coated tablets in children and adolescents with attention-deficit/hyperactivity disorder: results of a randomized, double-blind, placebo-controlled, flexible-dose study. *Pediatrics* 116, e777-e784.
- Bielekova, B., Goodwin, B., Richert, N., Cortese, I., Kondo, T., Afshar, G., Gran, B., Eaton, J., Antel, J., Frank, J. A., McFarland, H. F., Martin, R., 2000. Encephalitogenic potential of the myelin basic protein peptide (amino acids 83-99) in multiple sclerosis: Results of a phase II clinical trial with an altered peptide ligand. *Nature Medicine* 6, 1167-1175.
- Bigland-Ritchie, B., Cafarelli, E., Vøllestad, N., 1998. Fatigue of submaximal static contractions. *Acta Physiol Scand Suppl.* 556, 137-148.
- Billiard, M., Besset, A., Montplaisir, J., Laffont, F., Goldenberg, F., Weill, J. S., 1994. Modafinil: a double-blind multicentric study. *Sleep* 17, S107-S112.
- Bjartmar, C., Kidd, G., Mörk, S., Rudick, R., Trapp, B. D., 2000. Neurological disability correlates with spinal cord axonal loss and reduced N-acetyl aspartate in chronic multiple sclerosis patients. *Annals of Neurology* 48, 893-901.
- Black, J. E., Hirshkowitz, M., 2005. Modafinil for treatment of residual excessive sleepiness in nasal continuous positive airway pressure-treated obstructive sleep apnea/hypopnea syndrome. *Sleep* 28, 464-471.
- Bobholz, A. T., Rao, S. M., 2003. Cognitive dysfunction in multiple sclerosis: a review of recent developments. *Current Opinion in Neurology* 16, 283-288.
- Boellner, S. W., Earl, C. Q., Arora, S., 2006. Modafinil in children and adolescents with attention-deficit/hyperactivity disorder: a preliminary 8-week, open-label study\*. *Current Medical Research and Opinion* 22, 2457-2465.
- Boggild, M., 2009. Immunosuppression followed by immunomodulation. *Journal of the Neurological Sciences* 277, Supplement 1, S50-S54.

- Bolanos, J. P., Almeida, A., Stewart, V., Peuchen, S., Land, J. M., Clark, J. B., Heales, S. J. R., 1997. Nitric oxide-mediated mitochondrial damage in the brain: Mechanisms and implications for neurodegenerative diseases. *Journal of Neurochemistry* 68, 2227-2240.
- Bond, A., Lader, M., 1974. The use of analogue scales in rating subjective feelings. *British Journal of Medical Psychology* 47, 211-218.
- Bouaziz, J. D., Yanaba, K., Tedder, T. F., 2008. Regulatory B cells as inhibitors of immune responses and inflammation. *Immunol Rev.* 224, 201-214.
- Braley, T. J., Chervin, R. D., 2010. Fatigue in multiple sclerosis: mechanisms, evaluation, and treatment. *Sleep* 33, 1061-1067.
- Brand-Schieber, E., Werner, P., 2004. Calcium channel blockers ameliorate disease in a mouse model of multiple sclerosis. *Experimental Neurology* 189, 5-9.
- Brasil-Neto, J. P., Cohen, L. G., Hallett, M., 1994. Central fatigue as revealed by postexercise decrement of motor evoked potentials. *Muscle Nerve* 17, 13-19.
- Brass, S. D., Duquette, P., Proulx-Therrien, J., Auerbach, S., 2010. Sleep disorders in patients with multiple sclerosis. *Sleep Medicine Reviews* 14, 121-129.
- Brennan, A. R., Arnsten, A. F., 2008. Neuronal mechanisms underlying attention deficit hyperactivity disorder: the influence of arousal on prefrontal cortical function. *Annals of the New York Academy of Sciences* 1129, 236-245.
- Brioschi, A., Gramigna, S., Werth, E., Staub, F., Ruffieux, C., Bassetti, C., Schlupe, M., Annoni, J. M., 2009. Effect of Modafinil on Subjective Fatigue in Multiple Sclerosis and Stroke Patients. *European Neurology* 62, 243-249.
- Brocke, S., Gijbels, K., Allegretta, M., Ferber, I., Piercy, C., Blankensteini, T., Martin, R., Utz, U., Karin, N., Mitchell, D., Veromaa, T., Waisman, A., Gaur, A., Conlon, P., Ling, N., Fairchild, P. J., Wraith, D. C., O'Garra, A., Fathman, C. G., Steinman, L., 1996. Treatment of experimental encephalomyelitis with a peptide analogue of myelin basic protein. *Nature* 379, 343-346.
- Broughton, R. J., Fleming, J. A., George, C. F., Hill, J. D., Kryger, M. H., Moldofsky, H., 1997. Randomized, double-blind, placebo-controlled crossover trial of modafinil in the treatment of excessive daytime sleepiness in narcolepsy. *Neurology* 49, 444-451.
- Brownell, B., Hughes, J. T., 1962. The distribution of plaques in the cerebrum in multiple sclerosis. *Journal of Neurology, Neurosurgery and Psychiatry.* 25, 315-320.
- Bruck, W., Wegner, C., 2011. Insight into the mechanism of laquinimod action. *Journal of the Neurological Sciences* 306, 173-179.
- Brunn, A., Utermohlen, O., Carstov, M., Ruiz, M. S., Miletic, H., Schluter, D., Deckert, M., 2008. CD4 T cells mediate axonal damage and spinal cord motor neuron apoptosis in murine P0106-125-induced experimental autoimmune neuritis. *American Journal of Pathology* 173, 93-105.
- Bryant, M., Chiaravalloti, N. D., DeLuca, J., 2004. Objective measurement of cognitive fatigue in multiple sclerosis. *Rehabilitation Psychology* 49, 114-122.
- Bubser, M., Fadel, J. R., Jackson, L. L., Meador-Woodruff, J. H., Jing, D., Deutch, A. Y., 2005. Dopaminergic regulation of orexin neurons. *European Journal of Neuroscience* 21, 2993-3001.
- Business Wire., 2011. Top-line results from the first registrational trial for daclizumab HYP in relapsing-remitting multiple sclerosis. .

<http://www.businesswire.com/news/home/20110809005901/en>. [Accessed 13 January 2013].

Calabrese, M., Rinaldi, F., Grossi, P., Mattisi, I., Bernardi, V., Favaretto, A., Perini, P., Gallo, P., 2010. Basal ganglia and frontal/parietal cortical atrophy is associated with fatigue in relapsing-remitting multiple sclerosis. *Multiple Sclerosis* 16, 1220-1228.

Calabresi, P. A., Wilterdink, J. L., Rogg, J. M., Mills, P., Webb, A., Whartenby, K. A., 2002. An open-label trial of combination therapy with interferon beta-1a and oral methotrexate in MS. *Neurology* 58, 314-317.

Cannella, B., Pitt, D., Capello, E., Raine, C. S., 2000. Insulin-like growth factor-1 fails to enhance central nervous system myelin repair during autoimmune demyelination. *American Journal of Pathology* 157, 933-943.

Cantor, F., 2010. Central and Peripheral Fatigue: Exemplified by Multiple Sclerosis and Myasthenia Gravis. *PM&R* 2, 399-405.

Caseras, X., Mataix-Cols, D., Giampietro, V., Rimes, K. A., Brammer, M., Zelaya, F., Chalder, T., Godfrey, E. L., 2006. Probing the Working Memory System in Chronic Fatigue Syndrome: A Functional Magnetic Resonance Imaging Study Using the n-Back Task. *Psychosomatic Medicine* 68, 947-955.

Caseras, X., Mataix-Cols, D., Rimes, K. A., Giampietro, V., Brammer, M., Zelaya, F., Chalder, T., Godfrey, E., 2008. The neural correlates of fatigue: an exploratory imaginal fatigue provocation study in chronic fatigue syndrome. *Psychological Medicine* 38, 941-951.

Chan, K. M., Strohschein, F. J., Rydz, D., Allidina, A., Shuaib, A., Westbury, C. F., 2006. Randomized controlled trial of modafinil for the treatment of fatigue in postpolio patients. *Muscle & Nerve* 33, 138-141.

Chard, D. T., Griffin, C. M., McLean, M. A., Kapeller, P., Kapoor, R., Thompson, A. J., Miller, D. H., 2002. Brain metabolite changes in cortical grey and normal-appearing white matter in clinically early relapsing-remitting multiple sclerosis. *Brain* 125, 2342-2352.

Chaudhuri, A., Behan, P. O., 2000. Fatigue and basal ganglia. *Journal of the Neurological Sciences* 179, 34-42.

Chaudhuri, A., Behan, P. O., 2004. Fatigue in neurological disorders. *The Lancet* 363, 978-988.

Chelmicka-Schorr, E., Arnason, B. G., 1994. Nervous system-immune system interactions and their role in multiple sclerosis. *Annals of Neurology*. 36 S29-32.

Chemelli, R. M., Willie, J. T., Sinton, C. M., Elmquist, J. K., Scammell, T., Lee, C., Richardson, J. A., Williams, S. C., Xiong, Y., Kisanuki, Y., Fitch, T. E., Nakazato, M., Hammer, R. E., Saper, C. B., Yanagisawa, M., 1999. Narcolepsy in orexin Knockout Mice: Molecular Genetics of Sleep Regulation. *Cell* 98, 437-451.

Chien, J. M., Fissell, K., Jacobs, S., Fiez, J. A., 2002. Functional heterogeneity within Broca's area during verbal working memory. *Physiology & Behavior*. 77, 635-639.

Clark, A. J., Ware, M. A., Yazer, E., Murray, T. J., Lynch, M. E., 2004. Patterns of cannabis use among patients with multiple sclerosis. *Neurology* 62, 2098-2100.

Clinical Trials. gov., 2012. A study of ocrelizumab in comparison with interferon beta-1a in patients with relapsing multiple sclerosis. <http://clinicaltrials.gov/ct2/show/NCT01412333>. [Accessed 13 January 2013].

ClinicalTrials.gov., 2011. Efficacy and safety of daclizumab high yield process versus interferon  $\beta$  1a in patients with relapsing-remitting multiple sclerosis. <http://clinicaltrials.gov/ct2/show/NCT01064401>. [Accessed 13 January 2013].

ClinicalTrials.gov., 2011a. Efficacy and safety of teriflunomide in patients with relapsing multiple sclerosis and treated with interferon-beta (TERACLES). <http://clinicaltrials.gov/ct2/show/NCT01252355>. [Accessed 13 January 2013].

ClinicalTrials.gov., 2011b. Phase III study with teriflunomide versus placebo in patients with first clinical symptom of multiple sclerosis (TOPIC). <http://clinicaltrials.gov/ct2/show/NCT00622700>. [Accessed 13 January 2013].

Cohen, J. A., Calabresi, P. A., Chakraborty, S., Edwards, K. R., Eickenhorst, T., Felton, W. L., Fisher, E., Fox, R. J., Goodman, A. D., Hara-Cleaver, C., Hutton, G. J., Imrey, P. B., Ivancic, D. M., Mandell, B. F., Perryman, J. E., Scott, T. F., Skaramagas, T. T., Zhang, H., 2008. Avonex Combination Trial in relapsing-remitting MS: rationale, design and baseline data. *Multiple Sclerosis* 14, 370-382.

Cohen, J. A., Coles, A. J., Arnold, D. L., Confavreux, C., Fox, E. J., Hartung, H. P., Havrdova, E., Selmaj, K. W., Weiner, H. L., Fisher, E., Brinar, V. V., Giovannoni, G., Stojanovic, M., Ertik, B. I., Lake, S. L., Margolin, D. H., Panzara, M. A., Compston, D. A., investigators., C.-M. I., 2012. Alemtuzumab versus interferon beta 1a as first-line treatment for patients with relapsing-remitting multiple sclerosis: a randomised controlled phase 3 trial. *Lancet* 380, 1819-1828.

Cohen, J. A., Imrey, P. B., Calabresi, P. A., Edwards, K. R., Eickenhorst, T., Felton, W. L., Fisher, E., Fox, R. J., Goodman, A. D., Hara-Cleaver, C., Hutton, G. J., Mandell, B. F., Scott, T. F., Zhang, H., Apperson-Hansen, C., Beck, G. J., Houghtaling, P. L., Karafa, M. T., Stadtler, M., For the, A. C. T. I., 2009. Results of the Avonex Combination Trial (ACT) in relapsing-remitting MS. *Neurology* 72, 535-541.

Cohen, R. A., Fisher, M., 1989. Amantadine treatment of fatigue associated with multiple sclerosis. *Archives of Neurology* 46, 676-680.

Coles, A. J., Twyman, C. L., Arnold, D. L., Cohen, J. A., Confavreux, C., Fox, E. J., Hartung, H. P., Havrdova, E., Selmaj, K. W., Weiner, H. L., Miller, T., Fisher, E., Sandbrink, R., Lake, S., Margolin, D. H., Oyuella, P., Panzara, M. A., Compston, D. A., investigators., C.-M. I., 2012. Alemtuzumab for patients with relapsing multiple sclerosis after disease-modifying therapy: a randomised controlled phase 3 trial. *Lancet* 380 1829-1839.

Collins, D., Neelin, P., Peters, T., Evans, A., 1994. Automatic 3D intersubject registration of MR volumetric data in standardized Talairach Space. *J. Comput. Assist. Tomogr.* 18, 192-205.

Colombo, B., Martinelli Boneschi, F., Rossi, P., Rovaris, M., Maderna, L., Filippi, M., Comi, G., 2000. MRI and motor evoked potential findings in nondisabled multiple sclerosis patients with and without symptoms of fatigue. *Journal of Neurology* 247, 506-509.

Comi, G., 2013. Oral laquinimod reduced relapse rate and delayed progression of disability in ALLEGRO, a placebo-controlled phase 3 trial for relapsing remitting multiple sclerosis. <http://www.tevapharm.com/Pages/default.aspx>. [Accessed on 12 January 2013].

Comi, G., Filippi, M., Wolinsky, J. S., 2001a. European/Canadian multicenter, double-blind, randomized, placebo-controlled study of the effects of glatiramer acetate on magnetic resonance imaging--measured disease activity and burden in patients with relapsing multiple sclerosis. European/Canadian Glatiramer Acetate Study Group. *Annals of Neurology*. 49, 290-297.

Comi, G., Leocani, L., Rossi, P., Colombo, B., 2001b. Physiopathology and treatment of fatigue in multiple sclerosis. *Journal of Neurology* 248, 174-179.

- Compston, A., 1996. Remyelination of the central nervous system. *Multiple Sclerosis* 1, 388-392.
- Compston, A., 2007. Complexity and heterogeneity in demyelinating disease. *Brain* 130, 1178-1180.
- Compston, A., Coles, A., 2002. Multiple sclerosis. *The Lancet* 359, 1221-1231.
- Compston, A., Coles, A., 2008. Multiple sclerosis. *The Lancet* 372, 1502-1517.
- Confavreux, C., Vukusic, S., Adeleine, P., 2003. Early clinical predictors and progression of irreversible disability in multiple sclerosis: an amnesic process. *Brain* 126, 770-782.
- Consortium of Multiple Sclerosis Centers, 2011. Results of phase III Bravo trial. <http://bit.ly/oAuZD6>. [Accessed 12 January 2013].
- Constantinescu, C. S., Farooqi, N., O'Brien, K., Gran, B., 2011a. Experimental autoimmune encephalomyelitis (EAE) as a model for multiple sclerosis (MS). *British Journal of Pharmacology* 164, 1079-1106.
- Constantinescu, C. S., Niepel, G., Patterson, M., Judd, A., Braitch, M., Fahey, A. J., Harikrishnan, S., Edwards, L. J., Tench, C. R., Bennett, G. W., Ghatei, M., 2011b. Orexin A (hypocretin-1) levels are not reduced while cocaine/amphetamine regulated transcript levels are increased in the cerebrospinal fluid of patients with multiple sclerosis: No correlation with fatigue and sleepiness. *Journal of the Neurological Sciences* 307, 127-131.
- Cook, D. B., O'Connor, P. J., Lange, G., Steffener, J., 2007. Functional neuroimaging correlates of mental fatigue induced by cognition among chronic fatigue syndrome patients and controls. *NeuroImage* 136, 108-122.
- Cools, R., Robbins, T. W., 2004. Chemistry of the adaptive mind. *Philosophical transactions. Series A, Mathematical, physical, and engineering sciences* 362, 2871-2888.
- Cooper, M. R., Bird, H. M., Steinberg, M., 2009. Efficacy and Safety of Modafinil in the Treatment of Cancer-Related Fatigue. *The Annals of Pharmacotherapy* 43, 721-725.
- Crayton, H., Heyman, R. A., Rossman, H. S., 2004. A multimodal approach to managing the symptoms of multiple sclerosis. *Neurology* 63, S12-S18.
- Czeisler, C. A., Walsh, J. K., Roth, T., Hughes, R. J., Wright, K. P., Kingsbury, L., Arora, S., Schwartz, J. R. L., Niebler, G. E., Dinges, D. F., 2005. Modafinil for Excessive Sleepiness Associated with Shift-Work Sleep Disorder. *New England Journal of Medicine* 353, 476-486.
- Dackis, C. A., Kampman, K. M., Lynch, K. G., Pettinati, H. M., CP, O. B., 2005. A double-blind, placebo-controlled trial of modafinil for cocaine dependence. *Neuropsychopharmacology* 30, 205-211.
- Dackis, C. A., Kampman, K. M., Lynch, K. G., Plebani, J. G., Pettinati, H. M., Sparkman, T., O'Brien, C. P., 2012. A double-blind, placebo-controlled trial of modafinil for cocaine dependence. *Journal of Substance Abuse Treatment* 43, 303-312.
- de Lange, F. P., Kalkman, J. S., Bleijenberg, G., Hagoort, P., vd Werf, S. P., van der Meer, J. W. M., Toni, I., 2004. Neural correlates of the chronic fatigue syndrome-an fMRI study. *Brain* 127, 1948-1957.
- de Saint Hilaire, Z., Orosco, M., Rouch, C., Blanc, G., Nicolaidis, S., 2001. Variations in extracellular monoamines in the prefrontal cortex and medial hypothalamus after modafinil administration: a microdialysis study in rats. *NeuroReport* 12, 3533-3537.

- De Sereville, J. E., Boer, C., Rambert, F. A., Duteil, J., 1994. Lack of pre-synaptic dopaminergic involvement in modafinil activity in anaesthetized mice: in vivo voltammetry studies. *Neuropharmacology* 33, 755-761.
- De Stefano, N., Narayanan, S., Francis, S. J., Smith, S., Mortilla, M., Tartaglia, M. C., Bartolozzi, M. L., Guidi, L., Federico, A., Arnold, D. L., 2002. Diffuse Axonal and Tissue Injury in Patients With Multiple Sclerosis With Low Cerebral Lesion Load and No Disability. *Archives of Neurology* 59, 1565-1571.
- DeBattista, C., Lembke, A., Solvason, H. B., Ghebremichael, R., Poirier, J., 2004. A prospective trial of modafinil as an adjunctive treatment of major depression. *J Clin Psychopharmacol* 24, 87-90.
- Debouverie, M., Pittion-Vouyovitch, S., Louis, S., Roederer, T., Guillemin, F., 2007. Increasing incidence of multiple sclerosis among women in Lorraine, Eastern France. *Multiple Sclerosis* 13, 962-967.
- Della Marca, G., Restuccia, D., Rubino, M., Maiese, T., Tonali, P., 2004. Influence of modafinil on somatosensory input processing in the human brain-stem. *Clinical Neurophysiology* 115, 919-926.
- DeLuca, J., Genova, H. M., Hillary, F. G., Wylie, G., 2008. Neural correlates of cognitive fatigue in multiple sclerosis using functional MRI. *Journal of the Neurological Sciences* 270, 28-39.
- Dement, W. C., Hall, J., Walsh, J. K., 2003. Tiredness versus sleepiness: semantics or a target for public education? . *Sleep* 26, 485-486.
- Denic, A., Johnson, A. J., Bieber, A. J., Warrington, A. E., Rodriguez, M., Pirko, I., 2011. The relevance of animal models in multiple sclerosis research. *Pathophysiology* 18, 21-29.
- Deroche-Gamonet, V., Darnaudéry, M., Bruins-Slot, L., Piat, F., Le Moal, M., Piazza, P. V., 2002. Study of the addictive potential of modafinil in naive and cocaine-experienced rats. . *Psychopharmacology* 161, 387-395.
- Derosbo, N. K., Mendel, I., Bennun, A., 1995. Chronic relapsing experimental autoimmune encephalomyelitis with a delayed-onset and an atypical clinical course, induced in PL/J mice by myelin oligodendrocyte glycoprotein (MOG)-derived peptide - preliminary-analysis of MOG T-cell epitopes. *European Journal of Immunology* 25, 985-993.
- Deutch, A. Y., Goldstein, M., Roth, R. H., 1986. Activation of the locus coeruleus induced by selective stimulation of the ventral tegmental area. *Brain Research* 363, 307-314.
- Diem, R., SÄttler, M. B., Merkler, D., Demmer, I., Maier, K., Stadelmann, C., Ehrenreich, H., BÄhr, M., 2005. Combined therapy with methylprednisolone and erythropoietin in a model of multiple sclerosis. *Brain* 128, 375-385.
- Dinges, D. F., Weaver, T. E., 2003. Effects of modafinil on sustained attention performance and quality of life in OSA patients with residual sleepiness while being treated with nCPAP. *Sleep Medicine* 4, 393-402.
- Dittel, B. N., 2008. CD4 T cells: Balancing the coming and going of autoimmune-mediated inflammation in the CNS. *Brain, Behavior, and Immunity* 22, 421-430.
- Djaldetti, R., Ziv, I., Achiron, A., Melamed, E., 1996. Fatigue in multiple sclerosis compared with chronic fatigue syndrome: A quantitative assessment. *Neurology* 46, 632-635.
- Dopheide, M. M., Morgan, R. E., Rodvelt, K. R., Schachtman, T. R., Miller, D. K., 2007. Modafinil evokes striatal [3H]dopamine release and alters the subjective properties of stimulants. *European Journal of Pharmacology* 568, 112-123.

Dunlop, B. W., Crits-Christoph, P., Evans, D. L., Hirschowitz, J., Solvason, H. B., Rickels, K., Garlow, S. J., Gallop, R. J., Ninan, P. T., 2007. Coadministration of Modafinil and a Selective Serotonin Reuptake Inhibitor From the Initiation of Treatment of Major Depressive Disorder With Fatigue and Sleepiness: A Double-Blind, Placebo-Controlled Study. *Journal of Clinical Psychopharmacology* 27, 614-619.

Duteil, J., Rambert, F. A., Pessonier, J., Hermant, J. F., Gombert, R., Assous, E., 1990. Central alpha 1-adrenergic stimulation in relation to the behaviour stimulating effect of modafinil; studies with experimental animals. *European Journal of Pharmacology* 180, 49-58.

Dutta, R., McDonough, J., Yin, X. G., Peterson, J., Chang, A., Torres, T., Gudz, T., Macklin, E. B., Lewis, D. A., Fox, R. J., Rudick, R., Mirnics, K., Trapp, B. D., 2006. Mitochondrial dysfunction as a cause of axonal degeneration in multiple sclerosis patients. *Annals of Neurology* 59, 478-489.

Ebers, G., 2005. Prognostic factors for multiple sclerosis: the importance of natural history studies. *Journal of Neurology* 252, 15-20.

Ebers, G. C., 1998. Randomised double-blind placebo-controlled study of interferon beta-1a in relapsing/remitting multiple sclerosis. *The Lancet* 352, 1498-1504.

Ebers, G. C., Heigenhauser, L., Daumer, M., Lederer, C., JH Noseworthy, J. H., 2005. Multiple sclerosis, the measurement of disability and access to clinical trial data. Discussion paper 430 of the "Sonderforschungsbereich 386" of the DFG. <http://epub.ub.uni-muenchen.de/>. [Accessed 5 May 2012].

Egner, A., Phillips, V. L., Vora, R., Wiggers, E., 2003. Depression, fatigue, and health-related quality of life among people with advanced multiple sclerosis: Results from an exploratory telerehabilitation study. *NeuroRehabilitation* 18, 125-133.

Ehrenreich, H., Fischer, B., Norra, C., Schellenberger, F., Stender, N., Stiefel, M., Sirén A. L., A.-L., Paulus, W., Nave, K.-A., Gold, R., Bartels, C., 2007. Exploring recombinant human erythropoietin in chronic progressive multiple sclerosis. *Brain* 130, 2577-2588.

Eickhoff, S. B., Laird, A. R., Grefkes, C., Wang, L. E., Zilles, K., Fox, P. T., 2009. Coordinate-based activation likelihood estimation meta-analysis of neuroimaging data: A random-effects approach based on empirical estimates of spatial uncertainty. *Human Brain Mapping* 30, 2907-2926.

Elie Louboutin, J. P., 1995. Sympathetic skin response AND (SSR) AND is abnormal in multiple sclerosis. *Muscle Nerve* 18, 185-189.

Ellis, C. M., Monk, C., Simmons, A., Lemmens, G., Williams, S. C. R., Brammer, M., Bullmore, E., Parkes, J. D., 1999. Functional magnetic resonance imaging neuroactivation studies in normal subjects and subjects with the narcoleptic syndrome. Actions of modafinil. *Journal of Sleep Research* 8, 85-93.

Engber, T. M., Koury, E. J., Dennis, S. A., Miller, M. S., Contreras, P. C., Bhat, R. V., 1998. Differential patterns of regional c-Fos induction in the rat brain by amphetamine and the novel wakefulness-promoting agent modafinil. *Neuroscience Letters* 241, 95-98.

Erman, M., Rosenberg, R., 2007. for the US Modafinil Shift Work Sleep Disorder Study Group. Modafinil for excessive sleepiness associated with chronic shift work sleep disorder: effects on patient functioning and health-related quality of life. *Primary Care Companion to The Journal of Clinical Psychiatry* 9, 188-194.

Ewing, D. J., 1992. Analysis of heart rate variability and other non-invasive tests with special reference to diabetes mellitus. In: Bannister, R., Mathias, C.J. (Eds.), *Autonomic Failure. A*

Textbook of Clinical Disorders of the Autonomic Nervous System, third ed. Oxford University Press, Oxford, , pp. 667-689.

Fan, Y.-y., Hu, W.-w., Dai, H.-b., Zhang, J.-x., Zhang, L.-y., He, P., Shen, Y., Ohtsu, H., Wei, E.-q., Chen, Z., 2011. Activation of the central histaminergic system is involved in hypoxia-induced stroke tolerance in adult mice. *Journal of Cerebral Blood Flow & Metabolism* 31, 305-314.

Farooqi, N., Gran, B., Constantinescu, C. S., 2010. Are current disease-modifying therapeutics in multiple sclerosis justified on the basis of studies in experimental autoimmune encephalomyelitis? *Journal of Neurochemistry* 115, 829-844.

Farrell, M. A., Armstrong, H., Ebers, G. C., 1986. Oligoclonal bands in multiple sclerosis: Clinicalâ€”pathologic correlation. *Neurology* 36, 139-139-b.

Fassbender, K., , S. R., Mössner, R., Kischka, U., Kühnen, J., Schwartz, A., M., H., 1998. Mood disorders and dysfunction of the hypothalamic-pituitary-adrenal axis in multiple sclerosis: Association with cerebral inflammation. *Archives of Neurology* 55, 66-72.

Fava, M., Thase, M. E., DeBattista, C., 2005. A multicenter, placebo-controlled study of modafinil augmentation in partial responders to selective serotonin reuptake inhibitors with persistent fatigue and sleepiness. *Journal of Clinical Psychiatry* 66, 85-93.

Ferentinos, P., Kontaxakis, V., Havaki-Kontaxaki, B., Dikeos, D., Papadimitriou, G., 2010. The Fatigue Questionnaire: Standardization in patients with major depression. *Psychiatry Research* 177, 114-119.

Ferguson, B., Matyszak, M. K., Esiri, M. M., Perry, V. H., 1997. Axonal damage in acute multiple sclerosis lesions. *Brain* 120, 393-399.

Ferraro, L., Antonelli, T., Tanganelli, S., WT, O. C., Perez de la Mora, M., Mendez-Franco, J., 1999. The vigilance promoting drug modafinil increases extracellular glutamate levels in the medial preoptic area and the posterior hypothalamus of the conscious rat: prevention by local GABAA receptor blockade. *Neuropsychopharmacology* 20, 346-356.

Ferraro, L., Antonelli, T., WT, O. C., Tanganelli, S., Rambert, F., Fuxe, K., 1997. The antinarcotic drug modafinil increases glutamate release in thalamic areas and hippocampus. *NeuroReport* 8, 2883-2887.

Ferraro, L., Antonelli, T., WT, O. C., Tanganelli, S., Rambert, F. A., Fuxe, K., 1998. The effects of modafinil on striatal, pallidal and nigral GABA and glutamate release in the conscious rat: evidence for a preferential inhibition of striato-pallidal GABA transmission. *Neuroscience Letters* 253, 135-138.

Ferraro, L., Fuxe, K., Agnati, L., Tanganelli, S., Tomasini, M. C., Antonelli, T., 2005. Modafinil enhances the increase of extracellular serotonin levels induced by the antidepressant drugs fluoxetine and imipramine: A dual probe microdialysis study in awake rat. *Synapse* 55, 230-241.

Ferraro, L., Fuxe, K., Tanganelli, S., Fernandez, M., Rambert, F. A., Antonelli, T., 2000. Amplification of cortical serotonin release: a further neurochemical action of the vigilance-promoting drug modafinil. *Neuropharmacology* 39, 1974-1983.

Ferraro, L., Fuxe, K., Tanganelli, S., Tomasini, M. C., Rambert, F. A., Antonelli, T., 2002. Differential enhancement of dialysate serotonin levels in distinct brain regions of the awake rat by modafinil: possible relevance for wakefulness and depression. *Journal of Neuroscience Research* 68, 107-112.

Ferraro, L., Tanganelli, S., O'Connor, W. T., Antonelli, T., Rambert, F., Fuxe, K., 1996. The vigilance promoting drug modafinil decreases GABA release in the medial preoptic area and



in the posterior hypothalamus of the awake rat: Possible involvement of the serotonergic 5-HT<sub>3</sub> receptor. *Neuroscience Letters* 220, 5-8.

Figved, N., Klevan, G., Myhr, K. M., Glad, S., Nyland, H., Larsen, J. P., Harboe, E., Omdal, R., Aarsland, D., 2005. Neuropsychiatric symptoms in patients with multiple sclerosis. *Acta Psychiatrica Scandinavica* 112, 463-468.

Filippi, M., Rocca, M. A., Colombo, B., Falini, A., Codella, M., Scotti, G., Comi, G., 2002a. Functional Magnetic Resonance Imaging Correlates of Fatigue in Multiple Sclerosis. *NeuroImage* 15, 559-567.

Filippi, M., Rocca, M. A., Falini, A., Caputo, D., Ghezzi, A., Colombo, B., Scotti, G., Comi, G., 2002b. Correlations between Structural CNS Damage and Functional MRI Changes in Primary Progressive MS. *NeuroImage* 15, 537-546.

Finke, K., Dodds, C. M., Bublak, P., Regenthal, R., Baumann, F., Manly, T., Muller, U., 2010. Effects of modafinil and methylphenidate on visual attention capacity: a TVA-based study. *Psychopharmacology (Berl)* 210, 317-329.

Fisk, J., Ritvo, P., Ross, L., Haase, D., Marrie, T., Schlech, W., 1994a. Measuring the functional impact of fatigue: initial validation of the fatigue impact scale. *Clinical infectious diseases* 8 S79-83.

Fisk, J. D., Doble, S. E., 2002. Construction and validation of a fatigue impact scale for daily administration (D-FIS). *Quality of Life Research* 11, 263-272.

Fisk, J. D., Pontefract, A., Ritvo, P. G., Archibald, C. J., Murray, T. J., 1994b. The impact of fatigue on patients with multiple sclerosis. *Canadian Journal of Neurological Sciences* 21, 9-14.

Fitzgerald, K. D., Stern, E. R., Angstadt, M., Nicholson-Muth, K. C., Maynor, M. R., Welsh, R. C., Hanna, G. L., Taylor, S. F., 2010. Altered Function and Connectivity of the Medial Frontal Cortex in Pediatric Obsessive-Compulsive Disorder. *Biological Psychiatry* 68, 1039-1047.

Flachenecker, P., Reiners, K., Krauser, M., Wolf, A., Toyka, K. V., 2001. Autonomic dysfunction in multiple sclerosis is related to disease activity and progression of disability. *Multiple Sclerosis* 7, 327-334.

Flachenecker, P., Rufer, A., Bihler, I., Hippel, C., Reiners, K., Toyka, K. V., Kesselring, J., 2003. Fatigue in MS is related to sympathetic vasomotor dysfunction. *Neurology* 61, 851-853.

Fleming, I., Michaelis, U. R., Bredenkotter, D., Fisslthaler, B., Dehghani, F., Brandes, R. P., Busse, R., 2001. Endothelium-derived hyperpolarizing factor synthase (Cytochrome P450 2C9) is a functionally significant source of reactive oxygen species in coronary arteries. *Circulation research* 88, 44-51.

Flensner, G., Lindencrona, C., 2002. The cooling-suit: case studies of its influence on fatigue among eight individuals with multiple sclerosis. *Journal of Advanced Nursing* 37, 541-550.

Forbes, A., While, A., Mathes, L., Griffiths, P., 2006. Health problems and health-related quality of life in people with multiple sclerosis. *Clinical Rehabilitation* 20, 67-78.

Ford, H., Trigwell, P., Johnson, M., 1998. The nature of fatigue in multiple sclerosis. *Journal of Psychosomatic Research* 45, 33-38.

Ford, H. L., Gerry, E., Johnson, M., Williams, R., 2002. A prospective study of the incidence, prevalence and mortality of multiple sclerosis in Leeds. *Journal of Neurology* 249, 260-265.

- Fortini, A. S., Sanders, E. L., Weinshenker, B. G., Katzmann, J. A., 2003. Cerebrospinal Fluid Oligoclonal Bands in the Diagnosis of Multiple Sclerosis: Isoelectric Focusing with IgG Immunoblotting Compared with High-Resolution Agarose Gel Electrophoresis and Cerebrospinal Fluid IgG Index. *American journal of clinical pathology* 120, 672-675.
- Fox, R. J., Beall, E., Bhattacharyya, P., Chen, J. T., Sakaie, K., 2011. Advanced MRI in Multiple Sclerosis: Current Status and Future Challenges. *Neurologic Clinics* 29, 357-380.
- Fox, R. J., Miller, D. H., Phillips, J. T., Hutchinson, M., Havrdova, E., Kita, M., Yang, M., Raghupathi, K., Novas, M., Sweetser, M. T., Vigiotta, V., Dawson, K. T., 2012. Placebo-Controlled Phase 3 Study of Oral BG-12 or Glatiramer in Multiple Sclerosis. *New England Journal of Medicine* 367, 1087-1097.
- Frakey, L. L., Salloway, S., Buelow, M., Malloy, P., 2012. A Randomized, Double-Blind, Placebo-Controlled Trial of Modafinil for the Treatment of Apathy in Individuals With Mild-to-Moderate Alzheimer's Disease. *Journal of Clinical Psychiatry* 73, 796-801.
- Frank, J. A., Richert, N., Lewis, B., Bash, C., Howard, T., Civil, R., Stone, R., Eaton, J., McFarland, H., Leist, T., 2002. A pilot study of recombinant insulin-like growth factor-I in seven multiple sclerosis patients. *Multiple Sclerosis* 8, 24-29.
- Freedman, M., Wolinsky, J. S., Frangin, G. A., al., e., 2010. Oral teriflunomide or placebo added to glatiramer acetate for 6 months in patients with relapsing multiple sclerosis: safety and efficacy results. *Neurology* 74, A294.
- Freedman, M. S., Wolinsky, J. S., Byrnes, W. J., al., e., 2009. Oral teriflunomide or placebo added to interferon beta for 6 months in patients with relapsing multiple sclerosis: safety and efficacy results. *Multiple Sclerosis* 15, S273.
- Freeman, A., Ciliax, B., Bakay, R., Daley, J., Miller, R. D., Keating, G., Levey, A., Rye, D., 2001. Nigrostriatal collaterals to thalamus degenerate in parkinsonian animal models. *Annals of Neurology* 50, 321-329.
- Friese, M. A., Montalban, X., Willcox, N., Bell, J. I., Martin, R., Fugger, L., 2006. The value of animal models for drug development in multiple sclerosis. *Brain* 129, 1940-1952.
- Fry, 1998. Randomized trial of modafinil for the treatment of pathological somnolence in narcolepsy. *Annals of Neurology* 43, 88-97.
- Frye, M. A., Grunze, H., Suppes, T., McElroy, S. L., Keck, P. E., Jr., Walden, J., Leverich, G. S., Altshuler, L. L., Nakelsky, S., Hwang, S., Mintz, J., Post, R. M., 2007. A Placebo-Controlled Evaluation of Adjunctive Modafinil in the Treatment of Bipolar Depression. *American Journal of Psychiatry* 164, 1242-1249.
- Fujiwara, M., Egashira, N., 2004. New perspectives in the studies on endocannabinoid and cannabis: Abnormal behaviors associate with CB1 cannabinoid receptor and development of therapeutic application. *Journal of Pharmacological Sciences* 96, 362-366.
- Fukazawa, T., Kikuchi, S., Sasaki, H., Hamada, K., Hamada, T., Miyasaka, K., Tashiro, K., 1998. The significance of oligoclonal bands in multiple sclerosis in Japan: Relevance of immunogenetic backgrounds. *Journal of the Neurological Sciences* 158, 209-214.
- Fuxe, K., Janson, A. M., Rosen, L., Finnman, U. B., Tanganelli, S., Morari, M., Goldstein, M., Agnati, L. F., 1992. Evidence for a protective action of the vigilance promoting drug Modafinil on the MPTP-induced degeneration of the nigrostriatal dopamine neurons in the black mouse: An immunocytochemical and biochemical analysis. *Experimental Brain Research* 88, 117-130.

- Gallopin, T., Luppi, P. H., Rambert, F. A., Frydman, A., Fort, P., 2004. Effect of the wake-promoting agent modafinil on sleep-promoting neurons from the ventrolateral preoptic nucleus: an in vitro pharmacologic study. *Sleep* 27, 19-25.
- Garren, H., Ruiz, P. J., Watkins, T. A., Fontoura, P., Nguyen, L. V. T., Estline, E. R., Hirschberg, D. L., Steinman, L., 2001. Combination of gene delivery and DNA vaccination to protect from and reverse Th1 autoimmune disease via deviation to the Th2 pathway. *Immunity* 15, 15-22.
- Gay, D., Esiri, M., 1991. Blood-brain barrier damage in acute multiple sclerosis plaques. An immunocytological study. *Brain* 114, 557-572.
- Genmab., 2011. Science and Research. Available online: <http://bit.ly/pKyDGv>. [Accessed 13 January 2013].
- Genoud, S., Maricic, I., Kumar, V., Gage, F. H., 2005. Targeted expression of IGF-1 in the central nervous system fails to protect mice from experimental autoimmune encephalomyelitis. *Journal of Neuroimmunology* 168, 40-45.
- Genovese, C. R., Lazar, N. A., Nichols, T., 2002. Thresholding of Statistical Maps in Functional Neuroimaging Using the False Discovery Rate. *NeuroImage* 15, 870-878.
- Gerrard, P., Malcolm, R., 2007. Mechanisms of modafinil: a review of current research. *Neuropsychiatric Disease and Treatment* 3, 349-364.
- Ghahremani, D. G., Tabibnia, G., Monterosso, J., Helleman, G., Poldrack, R. A., London, E. D., 2011. Effect of Modafinil on Learning and Task-Related Brain Activity in Methamphetamine-Dependent and Healthy Individuals. *Neuropsychopharmacology* 36, 950-959.
- Gill, M., Haerich, P., Westcott, K., Godenick, K. L., Tucker, J. A., 2006. Cognitive performance following modafinil versus placebo in sleep-deprived emergency physicians: a double-blind randomized crossover study. *Academic emergency medicine* 13, 158-165.
- Gillson, G., Richards, T. L., Smith, R. B., Wright, J. V., 2002. A double-blind pilot study of the effect of Prokarin<sup>TM</sup> on fatigue in multiple sclerosis. *Multiple Sclerosis* 8, 30-35.
- Giovannoni, G., 2006. Multiple sclerosis related fatigue. *Journal of Neurology, Neurosurgery & Psychiatry* 77, 2-3.
- Giovannoni, G., Thompson, A. J., Miller, D. H., Thompson, E. J., 2001. Fatigue is not associated with raised inflammatory markers in multiple sclerosis. *Neurology* 57, 676-681.
- Gold, R., Buttgereit, F., Toyka, K. V., 2001. Mechanism of action of glucocorticosteroid hormones: possible implications for therapy of neuroimmunological disorders. *Journal of Neuroimmunology* 117, 1-8.
- Gold, R., Kappos, L., Arnold, D. L., Bar-Or, A., Giovannoni, G., Selmaj, K., Tornatore, C., Sweetser, M. T., Yang, M., Sheikh, S. I., Dawson, K. T., 2012. Placebo-Controlled Phase 3 Study of Oral BG-12 for Relapsing Multiple Sclerosis. *New England Journal of Medicine* 367, 1098-1107.
- Gold, R., Lington, C., Lassmann, H., 2006. Understanding pathogenesis and therapy of multiple sclerosis via animal models: 70 years of merits and culprits in experimental autoimmune encephalomyelitis research. *Brain* 129, 1953-1971.
- Goodman, A. D., Rossman, H., Bar-Or, A., Miller, A., Miller, D. H., Schmierer, K., Lublin, F., Khan, O., Bormann, N. M., Yang, M., Panzara, M. A., Sandrock, A. W., For the, G. I., 2009. GLANCE: Results of a phase 2, randomized, double-blind, placebo-controlled study. *Neurology* 72, 806-812.

- Goodwin, G., 1998. Mood disorder. In: Johnstone, E.C., Freeman, C.P.L., Zealley, A.K. (Eds.), *Companion to Psychiatric Studies*, sixth ed. Churchill Livingstone, Edinburgh, pp. 399-430.
- Gordon, D., Pavlovska, G., Glover, C. P., Uney, J. B., Wraith, D., Scolding, N. J., 2008. Human mesenchymal stem cells abrogate experimental allergic encephalomyelitis after intraperitoneal injection, and with sparse CNS infiltration. *Neuroscience Letters* 448, 71-73.
- Gottschalk, M., Kampfel, T., Flachenecker, P., et al., 2005. FA-tigue and regulation of the hypothalamo-pituitary-adrenal axis in multiple sclerosis. *Archives of Neurology* 62, 277-280.
- Goudriaan, A. E., Veltman, D. J., van den Brink, W., Dom, G., Schmaal, L., 2012. Neurophysiological effects of modafinil on cue-exposure in cocaine dependence: A randomized placebo-controlled cross-over study using pharmacological fMRI. *Addictive Behaviors* 38, 509-517.
- Goverman, J., Perchellet, A., Huseby, E., 2005. The role of CD8(+) T cells in multiple sclerosis and its animal models. *Current Drug Targets - Inflammation & Allergy* 4, 239-245.
- Govindaiah, G., Wang, Y., Cox, C. L., 2010. Dopamine enhances the excitability of somatosensory thalamocortical neurons. *Neuroscience* 170, 981-991.
- Granville, D. J., Tashakkor, B., Takeuchi, C., Gustafsson, Å. s. B., Huang, C., Sayen, M. R., Wentworth, P., Yeager, M., Gottlieb, R. A., 2004. Reduction of ischemia and reperfusion-induced myocardial damage by cytochrome P450 inhibitors. *Proceedings of the National Academy of Sciences of the United States of America* 101, 1321-1326.
- Greenhill, L. L., 2006. The science of stimulant abuse. *Pediatric Annals* 35, 552-556.
- Greenhill, L. L., Biederman, J., Boellner, S. W., Rugino, T. A., Sangal, R. B., Earl, C. Q., 2006. A randomized, double-blind, placebo-controlled study of modafinil film-coated tablets in children and adolescents with attention-deficit/hyperactivity disorder. *Journal of the American Academy of Child & Adolescent Psychiatry* 45, 503-511.
- Greenwood, J., Walters, C. E., Pryce, G., Kanuga, N., Beraud, E., Baker, D., Adamson, P., 2003. Lovastatin inhibits brain endothelial cell Rho-mediated lymphocyte migration and attenuates experimental autoimmune encephalomyelitis. *The FASEB journal : official publication of the Federation of American Societies for Experimental Biology* 17, 905-907.
- Haensch, C. A., Jörg, J., 2006. Autonomic dysfunction in multiple sclerosis *Journal of Neurology* 253 (Suppl. 1), I3-I9.
- Hagg, T., Varon, S., Louis, J.-C., 1993. Ciliary neurotrophic factor (CNTF) promotes low-affinity nerve growth factor receptor and CD4 expression by rat CNS microglia. *Journal of Neuroimmunology* 48, 177-187.
- Hainut, K., Duchateau, J., 1989. Muscle fatigue, effects of training and disuse. *Muscle Nerve* 12, 660-669.
- Happe, S., Pirker, W., Sauter, C., Klösch, G., Zeitlhofer, J., 2001. Successful treatment of excessive daytime sleepiness in Parkinson's disease with modafinil. *Journal of Neurology* 248, 632-634.
- Hart, C. L., Haney, M., Vosburg, S. K., Rubin, E., Foltin, R. W., 2008. Smoked Cocaine Self-Administration is Decreased by Modafinil. *Neuropsychopharmacology* 33, 761-768.
- Hauser, S. L., Waubant, E., Arnold, D. L., Vollmer, T., Antel, J., Fox, R. J., Bar-Or, A., Panzara, M., Sarkar, N., Agarwal, S., Langer-Gould, A., Smith, C. H., 2008. B-Cell Depletion

with Rituximab in Relapsing-Remitting Multiple Sclerosis. *New England Journal of Medicine* 358, 676-688.

Hawker, K., O'Connor, P., Freedman, M. S., Calabresi, P. A., Antel, J., Simon, J., Hauser, S., Waubant, E., Vollmer, T., Panitch, H., Zhang, J., Chin, P., Smith, C. H., 2009. Rituximab in patients with primary progressive multiple sclerosis: Results of a randomized double-blind placebo-controlled multicenter trial. *Annals of Neurology* 66, 460-471.

Heesen, C., Nawrath, L., Reich, C., Bauer, N., Schulz, K. H., Gold, S. M., 2006. Fatigue in multiple sclerosis: an example of cytokine mediated sickness behaviour? *Journal of Neurology, Neurosurgery & Psychiatry* 77, 34-39.

Hilaire, Z. d. S., Orosco, M., Rouch, C., Blanc, G. r., Nicolaidis, S., 2001. Variations in extracellular monoamines in the prefrontal cortex and medial hypothalamus after modafinil administration: a microdialysis study in rats. *NeuroReport* 12, 3533-3537.

Hindmarch, I., 1980. Psychomotor function and psychoactive drugs. *British Journal of Clinical Pharmacology* 10, 189-209.

Hoddes, E., Zarcone, V., Smythe, H., Phillips, R., Dement, W. C., 1973. Quantification of Sleepiness: A New Approach. *Psychophysiology* 10, 431-436.

Höftberger, R., Aboul-Enein, F., Brueck, W., Lucchinetti, C., Rodriguez, M., Schmidbauer, M., Jellinger, K., Lassmann, H., 2004. Expression of Major Histocompatibility Complex class I Molecules on the Different Cell Types in Multiple Sclerosis Lesions. *Brain Pathology* 14, 43-50.

Hohlfeld, R., Wekerle, H., 2001. Immunological update on multiple sclerosis. *Current Opinion in Neurology* 14, 299-304.

Honig, L. S., Sheremata, W. A., 1989. Magnetic resonance imaging of spinal cord lesions in multiple sclerosis. *Journal of Neurology, Neurosurgery & Psychiatry* 52, 459-466.

Hou, R. H., Freeman, C., Langley, R. W., Szabadi, E., Bradshaw, C. M., 2005. Does modafinil activate the locus coeruleus in man? Comparison of modafinil and clonidine on arousal and autonomic functions in human volunteers. *Psychopharmacology* 181, 537-549.

Hou, R. H., Langley, R. W., Szabadi, E., Bradshaw, C. M., 2007. Comparison of diphenhydramine and modafinil on arousal and autonomic functions in healthy volunteers. *Journal of Psychopharmacology* 21, 567-578.

Howlett, A. C., Barth, F., Bonner, T. I., Cabral, G., Casellas, P., Devane, W. A., Felder, C. C., Herkenham, M., Mackie, K., Martin, B. R., Mechoulam, R., Pertwee, R. G., 2002. International Union of Pharmacology. XXVII. Classification of Cannabinoid Receptors. *Pharmacological Reviews* 54, 161-202.

Hughes, R. A., Sendtner, M., Thoenen, H., 1993. Members of several gene families influence survival of rat motoneurons in vitro and in vivo. *Journal of Neuroscience Research* 36, 663-671.

Huitinga, I., De Groot, C. J., Van der Valk, P., Kamphorst, W., Tilders, F. J., Swaab, D. F., 2001. Hypothalamic lesions in multiple sclerosis. *Journal of Neuropathology & Experimental Neurology* 55, 1208-1218.

Hunter, M. D., Ganesan, V., Wilkinson, I. D., Spence, S. A., 2006. Impact of modafinil on prefrontal executive function in schizophrenia. *The American Journal of Psychiatry* 163, 2184-2186.

Huolman, S., Hämäläinen, P., Vorobyev, V., Ruutiainen, J., Parkkola, R., Laine, T., Hämäläinen, H., 2011. The effects of rivastigmine on processing speed and brain activation

in patients with multiple sclerosis and subjective cognitive fatigue. *Multiple Sclerosis Journal* 17, 1351-1361.

Idiman, E., Ozakbas, S., Dogan, Y., Kosehasanogullari, G., 2009. The significance of oligoclonal bands in multiple sclerosis: relevance of demographic and clinical features, and immunogenetic backgrounds. *Journal of Neuroimmunology*. 212, 121-124.

Imrell, K., Landtblom, A.-M., Hillert, J., Masterman, T., 2006. Multiple sclerosis with and without CSF bands: Clinically indistinguishable but immunogenetically distinct. *Neurology* 67, 1062-1064.

Induruwa, I., Constantinescu, C. S., Gran, B., 2012. Fatigue in multiple sclerosis - a brief review. *Journal of the Neurological Sciences* 323, 9-15.

Inglese, M., 2006. Multiple Sclerosis: New Insights and Trends. *American Journal of Neuroradiology* 27, 954-957.

Ishikuza, T., Murotani, T., Yamatodani, A., 2012. Action of modafinil through histaminergic and orexinergic neurons. *Vitamins & Hormones* 89, 259-278.

Ishizuka, T., Murakami, M., Yamatodani, A., 2008. Involvement of central histaminergic systems in modafinil-induced but not methylphenidate-induced increases in locomotor activity in rats. *European Journal of Pharmacology* 578, 209-215.

Ishizuka, T., Murotani, T., Yamatodani, A., 2010. Modafinil activates the histaminergic system through the orexinergic neurons. *Neuroscience Letters* 483, 193-196.

Ishizuka, T., Sakamoto, Y., Sakurai, T., Yamatodani, A., 2003. Modafinil increases histamine release in the anterior hypothalamus of rats. *Neuroscience Letters* 339, 143-146.

Jacobs, L. D., Cookfair, D. L., Rudick, R. A., et. al, 1996. Intramuscular interferon beta-1a for disease progression in relapsing multiple sclerosis. The Multiple Sclerosis Collaborative Research Group (MSCRG). *Annals of Neurology* 40, 285-294.

Janardhan, V., Bakshi, R., 2000. Quality of Life and Its Relationship to Brain Lesions and Atrophy on Magnetic Resonance Images in 60 Patients With Multiple Sclerosis. *Archives of Neurology* 57, 1485-1491.

Janardhan, V., Bakshi, R., 2002. Quality of life in patients with multiple sclerosis: The impact of fatigue and depression. *Journal of the Neurological Sciences* 205, 51-58.

Jenner, P., Zeng, B. Y., Smith, L. A., Pearce, R. K. B., Tel, B., Chancharme, L., Moachon, G., 2000. Antiparkinsonian and neuroprotective effects of modafinil in the mptp-treated common marmoset. *Experimental Brain Research* 133, 178-188.

Johns, M. W., 1991. A new method for measuring daytime sleepiness: the Epworth sleepiness scale. *Sleep* 14, 540-545.

Johnson, K. P., Brooks, B. R., Cohen, J. A., Ford, C. C., Goldstein, J., Lisak, R. P., Myers, L. W., Panitch, H. S., Rose, J. W., Schiffer, R. B., 1995. Copolymer 1 reduces relapse rate and improves disability in relapsing-remitting multiple sclerosis: results of a phase III multicenter, double-blind placebo-controlled trial. The Copolymer 1 Multiple Sclerosis Study Group. *Neurology* 45, 1268-1276.

Johnson, K. P., Brooks, B. R., Cohen, J. A., Ford, C. C., Goldstein, J., Lisak, R. P., Myers, L. W., Panitch, H. S., Rose, J. W., Schiffer, R. B., Vollmer, T., Weiner, L. P., Wolinsky, J. S., 1998. Extended use of glatiramer acetate (Copaxone) is well tolerated and maintains its clinical effect on multiple sclerosis relapse rate and degree of disability. Copolymer 1 Multiple Sclerosis Study Group. *Neurology* 50, 701-708.

Johnson, S. L., 2008. The Concept of Fatigue in Multiple Sclerosis. *The Journal of Neuroscience Nursing* 40, 72-77.

Jones, J. L., Anderson, J. M., Phuah, C.-L., Fox, E. J., Selmaj, K., Margolin, D., Lake, S. L., Palmer, J., Thompson, S. J., Wilkins, A., Webber, D. J., Compston, D. A., Coles, A. J., 2010. Improvement in disability after alemtuzumab treatment of multiple sclerosis is associated with neuroprotective autoimmunity. *Brain* 133, 2232-2247.

Joo, E. Y., Tae, W. S., Jung, K.-Y., Hong, S. B., 2008. Cerebral blood flow changes in man by wake-promoting drug, modafinil: a randomized double blind study. *Journal of Sleep Research* 17, 82-88.

Joseph, F. G., Hirst, C. L., Pickersgill, T. P., Ben-Shlomo, Y., Robertson, N. P., Scolding, N. J., 2009. CSF oligoclonal band status informs prognosis in multiple sclerosis: a case control study of 100 patients. *Journal of Neurology, Neurosurgery & Psychiatry* 80, 292-296.

Jung, J. C., Lee, Y., Son, J. Y., Lim, E., Jung, M., Oh, S., 2012. Simple synthesis of modafinil derivatives and their anti-inflammatory activity. *Molecules* 17, 10446-10458.

Kalechstein, A. D., De La Garza, R., 2nd, Newton, T. F., 2010. Modafinil administration improves working memory in methamphetamine-dependent individuals who demonstrate baseline impairment. *American Journal on Addictions* 19, 340-344.

Kaleita, T., Wellisch, D., Graham, C. e. a., 2006. Pilot study of modafinil for treatment of neurobehavioral dysfunction and fatigue in adult patients with brain tumors. *Journal of Clinical Oncology*, 2006 ASCO Annual Meeting Proceedings (Post-Meeting Edition), 24, : 1503

Kalkers, N. F., Barkhof, F., Bergers, E., van Schijndel, R., Polman, C. H., 2002. The effect of the neuroprotective agent riluzole on MRI parameters in primary progressive multiple sclerosis: a pilot study. *Multiple Sclerosis* 8, 532-533.

Kaminska, M., Kimoff, R. J., Schwartzman, K., Trojan, D. A., 2011. Sleep disorders and fatigue in multiple sclerosis: Evidence for association and interaction. *Journal of the Neurological Sciences* 302, 7-13.

Kapoor, R., Davies, M., Blaker, P. A., Hall, S. M., Smith, K. J., 2003. Blockers of sodium and calcium entry protect axons from nitric oxide-mediated degeneration. *Annals of Neurology* 53, 174-180.

Kapoor, R., Furby, J., Hayton, T., Smith, K. J., Altmann, D. R., Brenner, R., Chataway, J., Hughes, R. A. C., Miller, D. H., 2008. Lamotrigine for neuroprotection in secondary progressive multiple sclerosis: a randomised, double-blind, placebo-controlled, parallel-group trial. *The Lancet Neurology* 9, 681-688.

Kappos, L., Antel, J., Comi, G., Montalban, X., O'Connor, P., Polman, C. H., Haas, T., Korn, A. A., Karlsson, G., Radue, E. W., 2006a. Oral Fingolimod (FTY720) for Relapsing Multiple Sclerosis. *New England Journal of Medicine* 355, 1124-1140.

Kappos, L., Li, D., Calabresi, P., al., e., 2011. Ocrelizumab in relapsing-remitting multiple sclerosis: 48 week efficacy and safety results of a phase II randomized placebo-controlled multicenter trial. In: Program and abstracts of the American Academy of Neurology (AAN) 63rd Annual Meeting; 9–16 April 2011; Honolulu, Hawaii.

Kappos, L., Traboulsee, A., Constantinescu, C., Eralinna, J. P., Forrestal, F., Jongen, P., Pollard, J., Sandberg-Wollheim, M., Sindic, C., Stubinski, B., Uitdehaag, B., Li, D., 2006b. Long-term subcutaneous interferon beta-1a therapy in patients with relapsing-remitting MS. *Neurology* 67, 944-953.

- Kassis, I., Grigoriadis, N., Gowda-Kurkalli, B., Mizrachi-Kol, R., Ben-Hur, T., Slavin, S., Abramsky, O., Karussis, D., 2008. Neuroprotection and Immunomodulation With Mesenchymal Stem Cells in Chronic Experimental Autoimmune Encephalomyelitis. *Arch Neurol* 65, 753-761.
- Kaynak, H., Altıntaş, A., Kaynak, D., Uyanik, Ö., Saip, S., Ağaoğlu, J., Önder, G., Siva, A., 2006. Fatigue and sleep disturbance in multiple sclerosis. *European Journal of Neurology* 13, 1333-1339.
- Kearney, D. J., Crump, C., Maynard, C., Boyko, E. J., 2003. A case-control study of endoscopy and mortality from adenocarcinoma of the esophagus or gastric cardia in persons with GERD. *Gastrointestinal Endoscopy* 57, 823-829.
- Kent-Braun, J. A., Sharma, K. R., Miller, R. G., Weiner, M. W., 1994. Postexercise phosphocreatine resynthesis is slowed in multiple sclerosis. *Muscle Nerve* 17, 835-8341.
- Kikuchi, S., Fukazawa, T., Niino, M., Yabe, I., Miyagishi, R., Hamada, T., Hashimoto, S. A., Tashiro, K., 2003. HLA-related subpopulations of MS in Japanese with and without oligoclonal IgG bands. *Neurology* 60, 647-651.
- Kim, Y. K., Yoon, I. Y., Shin, Y. K., Cho, S. S., Kim, S. E., 2007. Modafinil-induced hippocampal activation in narcolepsy. *Neuroscience Letters* 4, 91-96.
- Kingshott, R., Vennelle, M., EL., C., 2001. Randomized, double-blind, placebo-controlled crossover trial of modafinil in the treatment of residual daytime excessive sleepiness in the sleep apnea/hypopneac syndrome. *American Journal of Respiratory and Critical Care Medicine* 163, 918-923.
- Kobelt, G., Berg, J., Lindgren, P., Kerrigan, J., Russell, N., Nixon, R., 2006. Costs and quality of life of multiple sclerosis in the United Kingdom. *The European Journal of Health Economics* 7, 96-104.
- Koch, M., Heersema, D., Mostert, J., Teelken, A., Keyser, J. D., 2007. Cerebrospinal fluid oligoclonal bands and progression of disability in multiple sclerosis. *European Journal of Neurology* 14, 797-800.
- Koritschoner, R., Schweinburg, F., 1925. Klinisch und experimentelle beobachtungen über Lähmungen nach Wutschutzimpfung. . *Z. Immunitats Forsh* 42, 217-283 (in German).
- Kornek, B., Lassmann, H., 1999. Axonal pathology in multiple sclerosis. A historical note. *Brain Pathology* 9, 651-656.
- Kornek, B., Storch, M. K., Bauer, J., Djamshidian, A., Weissert, R., Wallstroem, E., Stefferl, A., Zimprich, F., Olsson, T., Linington, C., Schmidbauer, M., Lassmann, H., 2001. Distribution of a calcium channel subunit in dystrophic axons in multiple sclerosis and experimental autoimmune encephalomyelitis. *Brain* 124, 1114-1124.
- Korotkova, T. M., Klyuch, B. P., Ponomarenko, A. A., Lin, J. S., Haas, H. L., Sergeeva, O. A., 2006. Modafinil inhibits rat midbrain dopaminergic neurons through D2-like receptors. *Neuropharmacology* 52, 626-633.
- Kos, D., Kerckhofs, E., Nagels, G., D'Hooghe, M. B., Ilsbroukx, S., 2008. Review article: Origin of fatigue in multiple sclerosis: Review of the literature. *Neurorehabilitation and Neural Repair* 22, 91-100.
- Kostulas, V. K., Link, H., Lefvert, A. K., 1987. Oligoclonal IgG bands in cerebrospinal fluid. Principles for demonstration and interpretation based on findings in 1114 neurological patients. *Archives of Neurology* 44, 1041-1044.



- Kreitzer, A. C., Regehr, W. G., 2001. Cerebellar depolarization-induced suppression of inhibition is mediated by endogenous cannabinoids. *The Journal of Neuroscience* 21, RC174.
- Krupp, L., 2006. Editorial. *Multiple Sclerosis* 12, 367-368.
- Krupp, L. B., 2003. Fatigue in multiple sclerosis: definition, pathophysiology and treatment. *CNS Drugs* 17, 225–234.
- Krupp, L. b., Alvarez, L. A., LaRocca, N. G., Scheinberg, L. C., 1988. Fatigue in multiple sclerosis. *Archives of Neurology* 45, 435-437.
- Krupp, L. B., Christodoulou, C., 2001. Fatigue in multiple sclerosis. *Current Neurology and Neuroscience Reports* 1, 294-8.
- Krupp, L. B., Coyle, P. K., Doscher, C., Miller, A., Cross, A. H., Jandorf, L., Halper, J., Johnson, B., Morgante, L., Grimson, R., 1995. Fatigue therapy in multiple sclerosis: results of a double-blind, randomized, parallel trial of amantadine, pemoline, and placebo. *Neurology* 45, 1956-1961.
- Krupp, L. B., LaRocca, N. G., Muir-Nash, J., Steinberg, A. D., 1989. The Fatigue Severity Scale: Application to Patients With Multiple Sclerosis and Systemic Lupus Erythematosus. *Archives of Neurology* 46, 1121-1123.
- Krupp, L. B., Serafin, D. J., Christodoulou, C., 2010. Multiple sclerosis-associated fatigue. *Expert Review of Neurotherapeutics* 10, 1437-1447.
- Kumar, R., 2008. Approved and Investigational Uses of Modafinil: An Evidence-Based Review. *Drugs* 68, 1803-1839.
- Kurtzke, J. F., 1983. Rating neurologic impairment in multiple sclerosis. *Neurology* 33, 1444.
- Kutzelnigg, A., Lucchinetti, C. F., Stadelmann, C., Bruck, W., Rauschka, H., Bergmann, M., Schmidbauer, M., Parisi, J. E., Lassmann, H., 2005. Cortical demyelination and diffuse white matter injury in multiple sclerosis. *Brain* 128, 2705-2712.
- La Mantia, L., Milanese, C., Mascoli, N., D'Amico, R., Weinstock-Guttman, B., 2007. Cyclophosphamide for multiple sclerosis. *Cochrane Database Syst Rev*.1.
- Laberge, L., Bégin, P., Montplaisir, J., Mathieu, J., 2004. Sleep complaints in patients with myotonic dystrophy. *Journal of Sleep Research* 13, 95-100.
- Lallement, G., Pierard, C., Masqueliez, C., Pernot-Marino, I., Peres, M., Lagarde, D., 1997. Neuroprotective effect of modafinil against soman-induced hippocampal lesions. *Medical Science Research* 25, 437-440.
- Lando, Z., Teitelbaum, D., Arnon, R., 1980. Induction of experimental allergic encephalomyelitis in genetically resistant strains of mice. *Nature* 287, 551-552.
- Lange, R., Volkmer, M., Heesen, C., Liepert, J., 2009. Modafinil effects in multiple sclerosis patients with fatigue. *Journal of Neurology* 256, 645-650.
- Lanz, S., Seifert, F., MaihÄ¶fner, C., 2011. Brain activity associated with pain, hyperalgesia and allodynia: an ALE meta-analysis. *Journal of Neural Transmission* 118, 1139-1154.
- Larijani, G. E., Goldberg, M. E., Hojat, M., Khaleghi, B., Dunn, J. B., Marr, A. T., 2004. Modafinil Improves Recovery After General Anesthesia. *Anesthesia & Analgesia* 98, 976-981.

- Lassmann, H., Brück, W., Lucchinetti, C. F., 2007. The Immunopathology of Multiple Sclerosis: An Overview. *Brain Pathology* 17, 210-218.
- Lassmann, H., Lucchinetti, C. F., 2008. Cortical demyelination in CNS inflammatory demyelinating diseases. *Neurology* 70, 332-333.
- Lassmann, H., van Horssen, J., Mahad, D., 2012. Progressive multiple sclerosis: pathology and pathogenesis. *Nature Reviews Neurology* 8, 647-656.
- Lassmann, H., Wisniewski, H., 1979. Chronic relapsing experimental allergic encephalomyelitis: clinicopathological comparison with multiple sclerosis. *Archives of Neurology* 36, 490-497.
- Leary, S. M., Porter, B., Thompson, A. J., 2005. Multiple sclerosis: diagnosis and the management of acute relapses. *Postgraduate Medical Journal* 81, 302-308.
- Leavitt, V. M., Sumowski, J. F., Chiaravalloti, N., Deluca, J., 2012. Warmer outdoor temperature is associated with worse cognitive status in multiple sclerosis. *Neurology*. 78, 964-968.
- Lechner-Scott, J., Spencer, B., de Malmarche, T., Attia, J., Fitzgerald, M., Trojano, M., Grand'Maison, F., Gomez, J. A. C., Izquierdo, G., Duquette, P., Girard, M., Grammond, P., Oreja-Guevara, C., Hupperts, R., Bergamaschi, R., Boz, C., Giuliani, G., van Pesch, V., Iuliano, G., Fiol, M., Cristiano, E., Verheul, F., Saladino, M. L., Slee, M., Barnett, M., Deri, N., Flechter, S., Vella, N., Shaw, C., Herbert, J., Moore, F., Petkovska-Boskova, T., Jokubaitis, V., Butzkueven, H., 2012. The frequency of CSF oligoclonal banding in multiple sclerosis increases with latitude. *Multiple Sclerosis Journal* 18, 974-982.
- Lee, D. H., Linker, R. A., Gold, R., 2008. Spotlight on fumarates. *The International MS Journal* 15, 12-18.
- Leech, R., Braga, R., Sharp, D. J., 2012. Echoes of the brain within the posterior cingulate cortex. *The Journal of Neuroscience* 32, 215-222.
- Leocani, L., Colombo, B., Comi, G., 2008. Physiopathology of fatigue in Multiple Sclerosis. *Neurological Sciences* 29, 241-243.
- Leocani, L., Colombo, B., Magnani, G., Martinelli-Boneschi, F., Cursi, M., Rossi, P., Martinelli, V., Comi, G., 2001. Fatigue in Multiple Sclerosis Is Associated with Abnormal Cortical Activation to Voluntary Movement-EEG Evidence. *NeuroImage* 13, 1186-1192.
- Lerdal, A., Gulowsen Celius, E., Krupp, L., Dahl, A. A., 2007. A prospective study of patterns of fatigue in multiple sclerosis. *European Journal of Neurology* 14, 1338-1343.
- Levy, F., 2009. Dopamine vs noradrenaline: inverted-U effects and ADHD theories. *Australian and New Zealand Journal of Psychiatry* 43, 101-108.
- Li, W., Quigley, L., Yao, D. L., Hudson, L. D., Brenner, M., Zhang, B. J., Brocke, S., McFarland, H. F., Webster, H. D., 1998. Chronic relapsing experimental autoimmune encephalomyelitis: Effects of insulin-like growth factor-I treatment on clinical deficits, lesion severity, glial responses, and blood brain barrier defects. *Journal of Neuropathology and Experimental Neurology* 57, 426-438.
- Lim, S. Y., Constantinescu, C. S., 2010. Current and future disease-modifying therapies in multiple sclerosis. *International Journal of Clinical Practice* 64, 637-650.
- Lin, J.-S., Anaclet, C., Sergeeva, O., Haas, H., 2011. The waking brain: an update. *Cellular and Molecular Life Sciences* 68, 2499-2512.

- Lin, J. S., Roussel, B., Akaoka, H., Fort, P., Debilly, G., Jouvet, M., 1992. Role of catecholamines in the modafinil and amphetamine induced wakefulness, a comparative pharmacological study in the cat. *Brain Res* 591, 319-326.
- Lincoln, M. R., Ebers, G. C., 2012. Robert Whytt, Benjamin Franklin, and the first probable case of multiple sclerosis. *Annals of Neurology* 72, 307-311.
- Linden, D., Diehl, R., Berlit, P., 1995. Subclinical autonomic disturbances in multiple sclerosis. *Journal of Neurology*. 242, 374-378.
- Linden, D., Diehl, R. R., Kretzschmar, A., Berlit, P., 1997. Autonomic evaluation by means of standard tests and power spectral analysis in multiple sclerosis. *Muscle Nerve* 20, 809–814
- Lindsay, S., Gudelsky, G., Heaton, P., 2006. Use of modafinil for the treatment of attention deficit/hyperactivity disorder. *Annals pharmacotherapy* 40, 1829–1833.
- Link, H., Huang, Y.-M., 2006. Oligoclonal bands in multiple sclerosis cerebrospinal fluid: An update on methodology and clinical usefulness. *Journal of Neuroimmunology* 180, 17-28.
- Littleton, E. T., Hobart, J. C., Palace, J., 2010. Modafinil for multiple sclerosis fatigue: Does it work? *Clinical Neurology and Neurosurgery* 112, 29-31.
- Logothetis, N. K., Pauls, J., Augath, M., Trinath, T., Oeltermann, A., 2001. Neurophysiological investigation of the basis of the fMRI signal. *Nature* 412, 150 - 157.
- Losseff, N. A., Wang, L., Lai, H. M., Yoo, D. S., GawneCain, M. L., McDonald, W. I., Miller, D. H., Thompson, A. J., 1996. Progressive cerebral atrophy in multiple sclerosis - A serial MRI study. *Brain* 119, 2009-2019.
- Lou, J.-S., Dimitrova, D. M., Park, B. S., Johnson, S. C., Eaton, R., Arnold, G., Nutt, J. G., 2009. Using Modafinil to Treat Fatigue in Parkinson Disease: A Double-Blind, Placebo-Controlled Pilot Study. *Clinical Neuropharmacology* 32, 305-310.
- Lou, J., 2009. Physical and mental fatigue in Parkinson's disease: epidemiology, pathophysiology and treatment. *Drugs Aging*. 26, 195-208.
- Lourenco, P., Shirani, A., Saedi, J., Oger, J., Schreiber, W. E., Tremlett, H., 2012. Oligoclonal bands and cerebrospinal fluid markers in multiple sclerosis: associations with disease course and progression. *Multiple Sclerosis Journal*. Available online: <http://msj.sagepub.com/content/early/2012/09/05/1352458512459684.long>, [Accessed on 12 October 2012].
- Lovett-Racke, A. E., Hussain, R. Z., Northrop, S., Choy, J., Rocchini, A., Matthes, L., Chavis, J. A., Diab, A., Drew, P. D., Racke, M. K., 2004. Peroxisome Proliferator-Activated Receptor  $\alpha$  Agonists as Therapy for Autoimmune Disease. *Journal of Immunology* 172, 5790-5798.
- Lowenstein, O., Feinberg, R., Loewenfeld, I. E., 1963. Pupillary movements during acute and chronic fatigue. *Investigative Ophthalmology & Visual Science* 2, 138-157.
- Lu, J., Zhou, T. C., Saper, C. B., 2006. Identification of Wake-Active Dopaminergic Neurons in the Ventral Periaqueductal Gray Matter. *The Journal of Neuroscience* 26, 193-202.
- Lublin, F. D., Reingold, S. C., 1996. Defining the clinical course of multiple sclerosis. *Neurology* 46, 907-911.
- Lucchinetti, C., Bruck, W., Parisi, J., Scheithauer, B., Rodriguez, M., Lassmann, H., 2000. Heterogeneity of multiple sclerosis lesions: Implications for the pathogenesis of demyelination. *Annals of Neurology* 47, 707-717.

Lucchinetti, C. F., Bruck, W., Lassmann, H., McDonald, W. I., John, H. N., 2003. Pathology and Pathogenesis of Multiple Sclerosis. Blue Books of Practical Neurology. Butterworth-Heinemann, pp. 93-113.

Luczak, A., Sobolewski, A., 2005. Longitudinal changes in critical flicker fusion frequency: an indicator of human workload. *Ergonomics*. 48, 1770-1792.

Lüdtke, H., Wilhelm, B., Adler, M., Schaeffel, F., Wilhelm, H., 1998. Mathematical procedures in data recording and processing of pupillary fatigue waves. *Vision Research* 38, 2889-2896.

MacAllister, W. S., Krupp, L. B., 2005. Multiple sclerosis-related fatigue. *Physical medicine and rehabilitation clinics of North America* 16, 483-502.

MacDonald, J. R., Hill, J. D., Tarnopolsky, M. A., 2002. Modafinil reduces excessive somnolence and enhances mood in patients with myotonic dystrophy. *Neurology* 59, 1876-1880.

Madras, B. K., Xie, Z., Lin, Z., Jassen, A., Panas, H., Lynch, L., Johnson, R., Livni, E., Spencer, T. J., Bonab, A. A., Miller, G. M., Fischman, A. J., 2006. Modafinil Occupies Dopamine and Norepinephrine Transporters in Vivo and Modulates the Transporters and Trace Amine Activity in Vitro. *Journal of Pharmacology and Experimental Therapeutics* 319, 561-569.

Magliozzi, R., Howell, O., Vora, A., Serafini, B., Nicholas, R., Puopolo, M., Reynolds, R., Aloisi, F., 2007. Meningeal B-cell follicles in secondary progressive multiple sclerosis associate with early onset of disease and severe cortical pathology. *Brain* 130, 1089-1104.

Mahdavian, S., Dike, U., Bryant, A., Davison, C., Ghazvini, P., Hill, A., 2010. Multiple Sclerosis. *Journal of Pharmacy Practice* 23, 91-100.

Mainero, C., Faroni, J., Gasperini, C., Filippi, M., Giugni, E., Ciccarelli, O., Rovaris, M., Bastianello, S., Comi, G., Pozzilli, C., 1999. Fatigue and magnetic resonance imaging activity in multiple sclerosis. *Journal of Neurology* 246, 454-458.

Makela, E., Miller, K., Cutlip, W., 2003. Three case reports of modafinil use in treating sedation induced by antipsychotic medications. *Journal of Clinical Psychiatry* 64, 485-486.

Makris, A. P., Rush, C. R., Frederich, R. C., Taylor, A. C., Kelly, T. H., 2007. Behavioral and subjective effects of D-amphetamine and modafinil in healthy adults. *Experimental and Clinical Psychopharmacology* 15, 123-133.

Marchetti, P., Gutierrez, J., Velia, P., Faucompre, J. L., Onraed, B., Formstecher, P., Hennache, B., 1999. Identification of IgG-specific oligoclonal banding in serum and cerebrospinal fluid by isoelectric focusing: Description of a simplified method for the diagnosis of neurological disorders. *Clinical Chemistry and Laboratory Medicine* 37, 735-738.

Mariani, J. J., Hart, C. L., 2005. Psychosis Associated With Modafinil and Shift Work. (Letter). *American journal of Psychiatry* 162, 1983-1983.

Marrie, R. A., Fisher, E., Miller, D. M., Lee, J.-C., Rudick, R. A., 2005. Association of fatigue and brain atrophy in multiple sclerosis. *Journal of the Neurological Sciences* 228, 161-166.

McDonald, W. I., Compston, A., Edan, G., Goodkin, D., Hartung, H. P., Lublin, F. D., McFarland, H. F., Paty, D. W., Polman, C. H., Reingold, S. C., Sandberg-Wollheim, M., Sibley, W., Thompson, A. J., van den Noort, S., Weinshenker, B. Y., Wolinsky, J. S., 2001. Recommended diagnostic criteria for multiple sclerosis: Guidelines from the International Panel on the Diagnosis of Multiple Sclerosis. *Annals of Neurology* 50, 121-127.

- McDougall, A. J., McLeod, J. G., 2003. Autonomic nervous system function in multiple sclerosis. *Journal of the Neurological Sciences* 215, 79-85.
- McGregor, C., Srisurapanont, M., Mitchell, A., Wickes, W., White, J. M., 2008. Symptoms and sleep patterns during inpatient treatment of methamphetamine withdrawal: A comparison of mirtazapine and modafinil with treatment as usual. *Journal of Substance Abuse Treatment* 35, 334-342.
- McLean, B. N., Luxton, R. W., Thompson, E. J., 1990. A study of immunoglobulin G in the cerebrospinal fluid of 1007 patients with suspected neurological disease using isoelectric focusing and the Log IgG-Index. A comparison and diagnostic applications. *Brain* 113, 1269-1289.
- McMorris, F. A., McKinnon, R. D., 1996. Regulation of oligodendrocyte development and CNS myelination by growth factors: prospects for therapy of demyelinating disease. *Brain Pathology* 6, 313-329.
- Meca-Lallana, J. E., Rodriguez-Hilario, H., Martinez-Vidal, S., Saura-Lujan, I., Dolly-Ballester, A., Escribano-Soriano, J. B., Martin-Fernandez, J., Genovés-Aleixandre, A., Mateo-Bosch, E., Fernandez-Barreiro, A., 2003. Plasmapheresis: its use in multiple sclerosis and other demyelinating processes of the central nervous system: An observation study. *Revista de Neurología* 37, 917-926.
- Medaer, R., 1979. Does the history of multiple sclerosis go back as far as the 14th-century. *Acta Neurologica Scandinavica* 60, 189-192.
- Medana, I., Martinic, M. A., Wekerle, H., Neumann, H., 2001. Transection of major histocompatibility complex class I-induced neurites by cytotoxic T lymphocytes. *American Journal of Pathology* 159, 809-815.
- Merkelbach, S., Dillmann, U., Kolmel, C., Holz, J., Muller, M., 2001. Cardiovascular autonomic dysregulation and fatigue in multiple sclerosis. *Multiple Sclerosis* 7, 320-326.
- Merkelbach, S., Haensch, C. A., Hemmer, B., Koehler, J., König, N. H., Ziemssen, T., 2006. Multiple sclerosis and the autonomic nervous system. *Journal of Neurology* 253 (Suppl. 1), I21-I25.
- Metz, L. M., Patten, S. B., Archibald, C. J., Bakker, J. I., Harris, C. J., Patry, D. G., Bell, R. B., Yeung, M., Murphy, W. F., Stoian, C. A., Billesberger, K., Tillotson, L., Peters, S., McGowan, D., 2004. The effect of immunomodulatory treatment on multiple sclerosis fatigue. *Journal of Neurology, Neurosurgery and Psychiatry* 75, 1045-1047.
- Michael, J., D., 2005. Histopathology of EAE. In: Lavi, E., & Constantinescu, C.S. (Eds). *Experimental Models of Multiple Sclerosis*. Springer, New York, pp. 25-43.
- Mignot, E., Nishino, S., Guilleminault, C., Dement, W. C., 1994. Modafinil binds to the dopamine uptake carrier site with low affinity. *Sleep* 17, 436-437.
- Mignot, E., Renaud, A., Nishino, S., Arrigoni, J., Guilleminault, C., Dement, W. C., 1993. Canine cataplexy is preferentially controlled by adrenergic mechanisms: evidence using monoamine selective uptake inhibitors and release enhancers. *Psychopharmacology* 113, 76-82.
- Miller, A. E., O'Connor, P., Wolinsky, J. S., Confavreux, C., Kappos, L., Olsson, T. P., Truffinet, P., Wang, L., D'Castrol, L., Comi, G., Freedman, M. S., for the Teriflunomide Multiple Sclerosis Trial, G., 2012. Pre-specified subgroup analyses of a placebo-controlled phase III trial (TEMSO) of oral teriflunomide in relapsing multiple sclerosis. *Multiple Sclerosis Journal* 18, 1625-1632.

- Miller, D., Grossman, R., Reingold, S., McFarland, H., 1998. The role of magnetic resonance techniques in understanding and managing multiple sclerosis. *Brain* 121, 3-24.
- Miller, R. G., Green, A. T., Moussavi, R. S., Carson, P. J., Weiner, M. W., 1990. Excessive muscular fatigue in patients with spastic paraparesis. *Neurology* 40, 1271-1274.
- Miller, S. D., Karpus, W. J., Davidson, T. S., 2010. Experimental Autoimmune Encephalomyelitis in the Mouse. *Current Protocols in Immunology*. John Wiley & Sons, Inc., pp. 15.11.11-15.11.20.
- Mills, R., Young, C., Pallant, J., Tennant, A., 2010. Development of a patient reported outcome scale for fatigue in multiple sclerosis: The Neurological Fatigue Index (NFI-MS). *Health and Quality of Life Outcomes* 8, 22.
- Mills, R. J., Young, C. A., 2008. A medical definition of fatigue in multiple sclerosis. *QJM: An International Journal of Medicine* 101, 49-60.
- Minzenberg, M. J., Carter, C. S., 2007. Modafinil: A Review of Neurochemical Actions and Effects on Cognition. *Neuropsychopharmacology* 33, 1477-1502.
- Minzenberg, M. J., Watrous, A. J., Yoon, J. H., Ursu, S., Carter, C. S., 2008. Modafinil Shifts Human Locus Coeruleus to Low-Tonic, High-Phasic Activity During Functional MRI. *Science* 322, 1700-1702.
- Minzenberg, M. J., Yoon, J. H., Carter, C. S., 2011. Modafinil modulation of the default mode network. *Psychopharmacology* 215, 23-31.
- Mitler, M. M., Harsh, J., Hirshkowitz, M., Guilleminault, C., 2000. Long-term efficacy and safety of modafinil (PROVIGIL<sup>(R)</sup>) for the treatment of excessive daytime sleepiness associated with narcolepsy. *Sleep Medicine* 1, 231-243.
- Mohr, D., Goodkin, D., Likosky, W., Beutler, L., Gatto, N., Langan, M., 1997. Identification of Beck Depression Inventory Items Related to Multiple Sclerosis. *Journal of Behavioral Medicine* 20, 407-414.
- Mohr, D. C., Boudewyn, A. C., Goodkin, D. E., Bostrom, A., Epstein, L., 2001a. Comparative outcomes for individual cognitive-behavior therapy, supportive-expressive group psychotherapy, and sertraline for the treatment of depression in multiple sclerosis. *Journal of Consulting and Clinical Psychology* 69, 942-949.
- Mohr, D. C., Goodkin, D. E., Islar, J., Hauser, S. L., Genain, C. P., 2001b. Treatment of depression is associated with suppression of nonspecific and antigen-specific th1 responses in multiple sclerosis. *Archives of Neurology* 58, 1081-1086.
- Möller, F., Poettgen, J., Broemel, F., Neuhaus, A., Daumer, M., Heesen, C., 2011. HAGIL (Hamburg Vigil Study): a randomized placebo-controlled double-blind study with modafinil for treatment of fatigue in patients with multiple sclerosis. *Multiple Sclerosis Journal* 17, 1002-1009.
- Montalban, X., Wolinsky, J., Yin, M., al., e., 2011. Phase III study of ocrelizumab in patients with primary progressive MS: ORATORIO design. . Program and abstracts of the American Academy of Neurology (AAN) 63rd Annual Meeting; 9–16 April 2011; Honolulu, Hawaii.
- Morgen, K., Sammer, G., Courtney, S. M., Wolters, T., Melchior, H., Blecker, C. R., Oschmann, P., Kaps, M., Vaitl, D., 2007. Distinct mechanisms of altered brain activation in patients with multiple sclerosis. *NeuroImage* 37, 937-946.
- Morrow, G. R., Gillies, L. J., Hickok, J. T., Roscoe, J. A., Padmanaban, D., Griggs, J. J., 2005. The positive effect of the psychostimulant modafinil on fatigue from cancer that persists after treatment is completed *Journal of Clinical Oncology* 23, 8012.

- Mostert, S., Kesselring, J., 2002. Effects of a short-term exercise training program on aerobic fitness, fatigue, health perception and activity level of subjects with multiple sclerosis. *Multiple Sclerosis* 8, 161-168.
- Moulin, D., Paty, D. W., Ebers, G. C., 1983. The predictive value of cerebrospinal fluid electrophoresis in a possible multiple sclerosis. *Brain* 106, 809-816.
- Muller, U., Steffenhagen, N., Regenthal, R., Bublak, P., 2004. Effects of modafinil on working memory processes in humans. *Psychopharmacology* 177, 161-169.
- Multiple Sclerosis Clinical Practice Guideline, 1999. *Fatigue and Multiple Sclerosis: Evidence-Based Management Strategies for Fatigue in Multiple Sclerosis*. Washington, DC: Paralyzed Veterans Association.
- Murillo-Rodriguez, E., Haro, R., Palomero-Rivero, M., Millan-Aldaco, D., Drucker-Colin, R., 2007. Modafinil enhances extracellular levels of dopamine in the nucleus accumbens and increases wakefulness in rats. *Behavioural Brain Research* 176, 353-357.
- Murray, T., 2009. The history of multiple sclerosis: the changing frame of the disease over the centuries. *Journal of the Neurological Sciences* 277, Supplement 1, S3-S8.
- Murray, T. J., 1985. Amantadine therapy for fatigue in multiple sclerosis. *Canadian Journal of Neurological Sciences* 12, 251-254.
- Myhr, K. M., Riise, T., Vedeler, C., Nortvedt, M. W., Grønning, M., Midgard, R., Nyland, H. I., 2001. Disability and prognosis in multiple sclerosis: demographic and clinical variables important for the ability to walk and awarding of disability pension. *Multiple Sclerosis* 7, 59-65.
- Nagels, G., D'Hooghe, M. B., Vleugels, L., Kos, D., Despontin, M., De Deyn, P. P., 2007. P300 and treatment effect of modafinil on fatigue in multiple sclerosis. *Journal of Clinical Neuroscience* 14, 33-40.
- Nakashima, I., Fujihara, K., Sato, S., Itoyama, Y., 2005. Oligoclonal IgG bands in Japanese patients with multiple sclerosis. A comparative study between isoelectric focusing with IgG immunofixation and high-resolution agarose gel electrophoresis. *Journal of Neuroimmunology* 159, 133-136.
- Nasseri, K., Uitdehaag, B. M. J., van Walderveen, M. A. A., Ader, H. J., Polman, C. H., 1999. Cardiovascular autonomic function in patients with relapsing remitting multiple sclerosis: a new surrogate marker of disease evolution?. *European Journal of Neurology* 6, 29-33.
- Nelson, F., Miller, A., O'Connor, P., al., e., 2011. Multiple sclerosis: monitoring and treatment. Magnetic resonance imaging subgroup analysis from the TEMSO placebo-controlled phase III trial of oral teriflunomide in multiple sclerosis with relapses. In: Program and abstracts of the European Neurological Association (ENS) 21st Annual Meeting; 28–31 May 2011; Lisbon, Portugal. .
- Neuhaus, O., Hartung, H. P., 2007. Evaluation of atorvastatin and simvastatin for treatment of multiple sclerosis. *Expert Review of Neurotherapeutics* 7, 547-556.
- Neumann, H., Medana, I. M., Bauer, J., Lassmann, H., 2002. Cytotoxic T lymphocytes in autoimmune and degenerative CNS diseases. *Trends in Neurosciences* 25, 313-319.
- Newton, J. L., Okonkwo, O., Sutcliffe, K., Seth, A., Shin, J., Jones, D. E. J., 2007. Symptoms of autonomic dysfunction in chronic fatigue syndrome. *QJM: An International Journal of Medicine* 100, 519-526.

Niepel, G., Bibani, R. H., Vilisaar, J., Langley, R. W., Bradshaw, C. M., Szabadi, E., Constantinescu, C. S., 2012. Association of a deficit of arousal with fatigue in multiple sclerosis: Effect of modafinil. *Neuropharmacology* 64, 380-388.

Niepel, G., Tench, C., Morgan, P., Evangelou, N., Auer, D., Constantinescu, C., 2006. Deep gray matter and fatigue in MS. *Journal of Neurology* 253, 896-902.

Nishino, S., 2003. The hypocretin//orexin system in health and disease. *Biological Psychiatry* 54, 87-95.

Nishino, S., Fruhstorfer, B., Arrigoni, J., Guilleminault, C., Dement, W. C., Mignot, E., 1993. Further characterization of the alpha-1 receptor subtype involved in the control of cataplexy in canine narcolepsy. *Journal of Pharmacology and Experimental Therapeutics* 264, 1079-1084.

Noble, J., Forooghian, F., Sproule, M., Westall, C., O'Connor, P., 2006. Utility of the National Eye Institute VFQ-25 Questionnaire in a Heterogeneous Group of Multiple Sclerosis Patients. *American Journal of Ophthalmology* 142, 464-468.

Norris, H., 1971. The action of sedatives on brain stem oculomotor systems in man. *Neuropharmacology* 10, 181-191.

Noseworthy, J. H., Lucchinetti, C., Rodriguez, M., Weinshenker, B. G., 2000. Multiple Sclerosis. *New England Journal of Medicine* 343, 938-952.

O'Brien, K., Fitzgerald, D., Rostami, A., Gran, B., 2010. The TLR7 agonist, imiquimod, increases IFN-beta production and reduces the severity of experimental autoimmune encephalomyelitis. *Journal of Neuroimmunology* 221, 107-111.

O'Connor, P., Filippi, M., Arnason, B., Comi, G., Cook, S., Goodin, D., Hartung, H. P., Jeffery, D., Kappos, L., Boate, F., Filippov, V., Groth, M., Knappertz, V., Kraus, C., Sandbrink, R., Pohl, C., Bogumil, T., 2009. 250 mcg or 500 mcg interferon beta-1b versus 20 mg glatiramer acetate in relapsing-remitting multiple sclerosis: a prospective, randomised, multicentre study. *The Lancet Neurology* 8, 889-897.

O'Connor, P. W., Li, D., Freedman, M. S., Bar-Or, A., Rice, G. P., Confavreux, C., Paty, D. W., Stewart, J. A., Scheyer, R., Group., T. M. S. T. G. U. o. B. C. M. M. R., 2006. A Phase II study of the safety and efficacy of teriflunomide in multiple sclerosis with relapses. *Neurology* 2028, 2894-2900.

Ondo, W. G., Fayle, R., Atassi, F., Jankovic, J., 2005. Modafinil for daytime somnolence in Parkinson's disease: double blind, placebo controlled parallel trial. *Journal of Neurology, Neurosurgery & Psychiatry* 76, 1636-1639.

Ouardouz, M., Coderre, E., Zamponi, G. W., Hameed, S., Yin, X., Trapp, B. D., Stys, P. K., 2009. Glutamate receptors on myelinated spinal cord axons: II. AMPA and GluR5 receptors. *Annals of Neurology* 65, 160-166.

Owens, G. P., Bennett, J. L., Gilden, D. H., Burgoon, M. P., 2006. The B cell response in multiple sclerosis. *Neurological Research* 28, 236-244.

Owens, G. P., Ritchie, A. M., Burgoon, M. P., Williamson, R. A., Corboy, J. R., Gilden, D. H., 2003. Single-Cell Repertoire Analysis Demonstrates that Clonal Expansion Is a Prominent Feature of the B Cell Response in Multiple Sclerosis Cerebrospinal Fluid. *The Journal of Immunology* 171, 2725-2733.

Ozdinler, P. H., Macklis, J. D., 2006. IGF-I specifically enhances axon outgrowth of corticospinal motor neurons. *Nat Neurosci* 9, 1371-1381.



Ozog, M. A., Modha, G., Church, J., Reilly, R., Naus, C. C., 2008. Co-administration of Ciliary Neurotrophic Factor with Its Soluble Receptor Protects against Neuronal Death and Enhances Neurite Outgrowth. *Journal of Biological Chemistry* 283, 6546-6560.

Paciaroni, M., Bogousslavsky, J., Marc, F., 2008. Chapter 1 The history of stroke and cerebrovascular disease. *Handbook of Clinical Neurology*. Elsevier, pp. 3-28.

Pack, A., Black, J., Schwartz, J., Matheson, J., 2001. Modafinil as adjunct therapy for daytime sleepiness in obstructive sleep apnea. *American Journal of Respiratory and Critical Care Medicine* 164, 1675-1681.

Paintlia, A. S., Paintlia, M. K., Singh, I., Skoff, R. B., Singh, A. K., 2009. Combination therapy of lovastatin and rolipram provides neuroprotection and promotes neurorepair in inflammatory demyelination model of multiple sclerosis. *GLIA* 57, 182-193.

Palmer, A. M., 2010. Teriflunomide, an inhibitor of dihydroorotate dehydrogenase for the potential oral treatment of multiple sclerosis. *Current opinion in investigational drugs* 11, 1313-1323.

Papatriantafyllou, M., 2013. Infection: The interferon paradox. *Nature Reviews Immunology* advance online publication. <http://www.nature.com/nri/journal/vaop/ncurrent/full/nri3461.html> [Accessed on 15 May 2013].

Parkin, D., Jacoby, A., McNamee, P., Miller, P., Thomas, S., Bates, D., 2000. Treatment of multiple sclerosis with interferon beta: an appraisal of cost-effectiveness and quality of life. *Journal of Neurology, Neurosurgery & Psychiatry* 68, 144-149.

Parmenter, B. A., Denney, D. R., Lynch, S. G., 2003. The cognitive performance of patients with multiple sclerosis during periods of high and low fatigue. *Multiple Sclerosis* 9, 111-118.

Parmentier, R., Anacleit, C., Guhenec, C., Brousseau, E., Bricout, D., Giboulot, T., Bozyczko-Coyne, D., Spiegel, K., Ohtsu, H., Williams, M., Lin, J. S., 2007. The brain H3-receptor as a novel therapeutic target for vigilance and sleep-wake disorders. *Biochemical Pharmacology* 73, 1157-1171.

Pearson, J. M., Heilbronner, S. R., Barack, D. L., Hayden, B. Y., Platt, M. L., 2011. Posterior cingulate cortex: adapting behavior to a changing world. *Trends in Cognitive Sciences* 15, 143-151.

Pellicano, C., Gallo, A., Li, X., Ikonomidou, V. N., Evangelou, I. E., Ohayon, J. M., Stern, S. K., Ehrmantraut, M., Cantor, F., McFarland, H. F., Bagnato, F., 2010. Relationship of cortical atrophy to fatigue in patients with multiple sclerosis. *Archives of Neurology* 67, 447-453.

Pender, M., 1995. Experimental autoimmune encephalomyelitis. In: Pender MP, McCombe PA, (eds). *Autoimmune neurological disease*. New York: Cambridge University Press, 26-88.

Peterson, J. W., Bo, L., Mork, S., Chang, A., Trapp, B. D., 2001. Transected neurites, apoptotic neurons, and reduced inflammation in cortical multiple sclerosis lesions. *Annals of Neurology* 50, 389-400.

Pettinelli, C. B., McFarlin, D. E., 1981. Adoptive transfer of experimental allergic encephalomyelitis in SJL/J mice after in vitro activation of lymph node cells by myelin basic protein: requirement for Lyt 1+ 2- T lymphocytes. *The Journal of Immunology* 127, 1420-1423.

Phadke, J. G., 1987. Survival pattern and cause of death in patients with multiple sclerosis: results from an epidemiological survey in north east Scotland. *Journal of Neurology, Neurosurgery & Psychiatry* 50, 523-531.

- Piérard, C., Satabin, P., Lagarde, D., Barrère, B., Guezennec, C. Y., Menu, J. P., Pérès, M., 1995. Effects of a vigilance-enhancing drug, modafinil, on rat brain metabolism: 2D COSY 1H-NMR study. *Brain Research* 693, 251-256.
- Pierre, J., Peloian, J., Wirshing, D., Wirshing, W., SR, M., 2007. A randomized, double-blind, placebo-controlled trial of modafinil for negative symptoms in schizophrenia. *Journal of Clinical Psychiatry* 68, 705-710.
- Pigeau, R., Naitoh, P., Buguet, A., McCann, C., Baranski, J., Taylor, M., 1995. Modafinil, d-amphetamine and placebo during 64 hours of sustained mental work. I. Effects on mood, fatigue, cognitive performance and body temperature. *Journal of Sleep Research* 4, 212-228.
- Pirttilä, T., Nurmikko, T., 1995. CSF oligoclonal bands, MRI, and the diagnosis of multiple sclerosis. *Acta Neurologica Scandinavica* 92, 468-471.
- Pitt, D., Werner, P., Raine, C. S., 2000. Glutamate excitotoxicity in a model of multiple sclerosis. *Nature Medicine* 6, 67-70.
- Pittock, S. J., McClelland, R. L., Mayr, W. T., Jorgensen, N. W., Weinshenker, B. G., Noseworthy, J., Rodriguez, M., 2004. Clinical implications of benign multiple sclerosis: A 20-year population-based follow-up study. *Annals of Neurology* 56, 303-306.
- Polak, P. E., Kalinin, S., Feinstein, D. L., 2011. Locus coeruleus damage and noradrenaline reductions in multiple sclerosis and experimental autoimmune encephalomyelitis. *Brain* 134, 665-677.
- Polman, C., Barkhof, F., Sandberg-Wollheim, M., Linde, A., Nordle, O., Nederman, T., for the Laquinimod in Relapsing, M. S. S. G., 2005a. Treatment with laquinimod reduces development of active MRI lesions in relapsing MS. *Neurology* 64, 987-991.
- Polman, C. H., O'Connor, P. W., Havrdova, E., Hutchinson, M., Kappos, L., Miller, D. H., Phillips, J. T., Lublin, F. D., Giovannoni, G., Wajgt, A., Toal, M., Lynn, F., Panzara, M. A., Sandrock, A. W., 2006. A Randomized, Placebo-Controlled Trial of Natalizumab for Relapsing Multiple Sclerosis. *New England Journal of Medicine* 354, 899-910.
- Polman, C. H., Reingold, S. C., Banwell, B., Clanet, M., Cohen, J. A., Filippi, M., Fujihara, K., Havrdova, E., Hutchinson, M., Kappos, L., Lublin, F. D., Montalban, X., O'Connor, P., Sandberg-Wollheim, M., Thompson, A. J., Waubant, E., Weinshenker, B., Wolinsky, J. S., 2011. Diagnostic criteria for multiple sclerosis: 2010 Revisions to the McDonald criteria. *Annals of Neurology* 69, 292-302.
- Polman, C. H., Reingold, S. C., Edan, G., Filippi, M., Hartung, H.-P., Kappos, L., Lublin, F. D., Metz, L. M., McFarland, H. F., O'Connor, P. W., Sandberg-Wollheim, M., Thompson, A. J., Weinshenker, B. G., Wolinsky, J. S., 2005b. Diagnostic criteria for multiple sclerosis: 2005 revisions to the "McDonald Criteria". *Annals of Neurology* 58, 840-846.
- Poser, C. M., 1994. The Dissemination of Multiple Sclerosis: A Viking Saga? A Historical Essay. *Annals of Neurology* 36, S231-S243.
- Poser, C. M., Paty, D. W., Scheinberg, L., 1983. New diagnostic criteria for multiple sclerosis: Guidelines for research protocols. *Annals of Neurology* 13, 227-231.
- Pryce, G., Ahmed, Z., Hankey, D. J. R., Jackson, S. J., Croxford, J. L., Pocock, J. M., Ledent, C., Petzold, A., Thompson, A. J., Giovannoni, G., Cuzner, M. L., Baker, D., 2003. Cannabinoids inhibit neurodegeneration in models of multiple sclerosis. *Brain* 126, 2191-2202.
- Pugliatti, M., Rosati, G., Carton, H., Riise, T., Drulovic, J., Vecsei, L., Milanov, I., 2006. The epidemiology of multiple sclerosis in Europe. *European Journal of Neurology* 13, 700-722.

- Pulicken, M., Bash, C. N., Costello, K., Said, A., Cuffari, C., Wilterdink, J. L., Rogg, J. M., Mills, P., Calabresi, P. A., 2005. Optimization of the safety and efficacy of interferon beta 1b and azathioprine combination therapy in multiple sclerosis. *Multiple Sclerosis* 11, 169-174.
- Qu, W.-M., Huang, Z.-L., Xu, X.-H., Matsumoto, N., Urade, Y., 2008. Dopaminergic D1 and D2 Receptors Are Essential for the Arousal Effect of Modafinil. *The Journal of Neuroscience* 28, 8462-8469.
- Rabkin, J. G., Gordon, P. H., McElhiney, M., Rabkin, R., Chew, S., Mitumoto, H., 2009. Modafinil treatment of fatigue in patients with ALS: A placebo-controlled study. *Muscle & Nerve* 39, 297-303.
- Racke, M. K., Hawker, K., Frohman, E. M., 2004. Fatigue in multiple sclerosis: is the picture getting simpler or more complex? . *Archives of Neurology* 61, 176-177.
- Rammohan, K. W., Rosenberg, J. H., Lynn, D. J., Blumenfeld, A. M., Pollak, C. P., Nagaraja, H. N., 2002. Efficacy and safety of modafinil (Provigil®) for the treatment of fatigue in multiple sclerosis: a two centre phase 2 study. *Journal of Neurology, Neurosurgery & Psychiatry* 72, 179-183.
- Randall, D. C., Cafferty, F. H., Shneerson, J. M., Smith, I. E., Llewelyn, M. B., File, S. E., 2005a. Chronic treatment with modafinil may not be beneficial in patients with chronic fatigue syndrome. *Journal of Psychopharmacology* 19, 647-660.
- Randall, D. C., Fleck, N. L., Shneerson, J. M., File, S. E., 2004. The cognitive-enhancing properties of modafinil are limited in non-sleep-deprived middle-aged volunteers. *Pharmacology Biochemistry & Behavior* 77, 547-555.
- Randall, D. C., Shneerson, J. M., File, S. E., 2005b. Cognitive effects of modafinil in student volunteers may depend on IQ. *Pharmacology Biochemistry & Behavior* 82, 133-139.
- Randall, D. C., Shneerson, J. M., Plaha, K. K., File, S. E., 2003. Modafinil affects mood, but not cognitive function, in healthy young volunteers. *Human Psychopharmacology* 18, 163-173.
- Rao, S. M., 2004. Cognitive function in patients with multiple sclerosis: impairment and treatment. *International Journal of MS Care* 1, 9-22.
- Rasetti, R., Mattay, V. S., Stankevich, B., Skjei, K., Blasi, G., Sambataro, F., Arrillaga-Romany, I. C., Goldberg, T. E., Callicott, J. H., Apud, J. A., Weinberger, D. R., 2010. Modulatory Effects of Modafinil on Neural Circuits Regulating Emotion and Cognition. *Neuropsychopharmacology* 35, 2101-2109.
- Reddy, H., Narayanan, S., Arnoutelis, R., Jenkinson, M., Antel, J., Matthews, P. M., Arnold, D. L., 2000a. Evidence for adaptive functional changes in the cerebral cortex with axonal injury from multiple sclerosis. *Brain* 123, 2314-2320.
- Reddy, H., Narayanan, S., Matthews, P. M., Hoge, R., Pike, G., Duquette, P., Antel, J., Arnold, D. L., 2000b. Relating axonal injury to functional recovery in MS. *Neurology*. 54, 236-239.
- Ritvo, P. G., Ftsk, J. D., Archibald, C. J., Murray, T. J., Field, C., 1996. Psychosocial and neurological predictors of mental health in multiple sclerosis patients. *Journal of Clinical Epidemiology* 49, 467-472.
- Rivers, T. M., Sprunt, D. H., Berry, G. P., 1933. Observations on attempts to produce acute disseminated encephalomyelitis in monkeys. *Journal of Experimental Medicine* 58, 39-U58.

Robertson Jr, P., Hellriegel, E. T., Arora, S., Nelson, M., 2002. Effect of modafinil at steady state on the single-dose pharmacokinetic profile of warfarin in healthy volunteers. *Journal of Clinical Pharmacology* 42, 205-214.

Robertson, P., DeCory, H. H., Madan, A., Parkinson, A., 2000. In vitro inhibition and induction of human hepatic cytochrome P450 enzymes by modafinil. *Drug Metabolism and Disposition* 28, 664-671.

Robertson, P. J., Hellriegel, E. T., 2003. Clinical Pharmacokinetic Profile of Modafinil. *Clinical Pharmacokinetics* 42, 123-137.

Robinson, W. H., Fontoura, P., Lee, B. J., de Vegvar, H. E. N., Tom, J., Pedotti, R., DiGennaro, C. D., Mitchell, D. J., Fong, D., Ho, P. P. K., Ruiz, P. J., Maverakis, E., Stevens, D. B., Bernard, C. C. A., Martin, R., Kuchroo, V. K., van Noort, J. M., Genain, C. P., Amor, S., Olsson, T., Utz, P. J., Garren, H., Steinman, L., 2003. Protein microarrays guide tolerizing DNA vaccine treatment of autoimmune encephalomyelitis. *Nature Biotechnology* 21, 1033-1039.

Rocca, M. A., Agosta, F., Colombo, B., Mezzapesa, D. M., Falini, A., Comi, G., Filippi, M., 2007. fMRI changes in relapsing-remitting multiple sclerosis patients complaining of fatigue after IFN $\beta$ -1a injection. *Human Brain Mapping* 28, 373-382.

Rocca, M. A., Falini, A., Colombo, B., S, cotti, G., Comi, G., Filippi, M., 2002a. Adaptive functional changes in the cerebral cortex of patients with nondisabling multiple sclerosis correlate with the extent of brain structural damage. *Annals of Neurology* 51, 330-339.

Rocca, M. A., Matthews, P. M., Caputo, D., Ghezzi, A., Falini, A., Scotti, G., Comi, G., Filippi, M., 2002b. Evidence for widespread movement-associated functional MRI changes in patients with PPMS. *Neurology*. 58, 866-872.

Roelcke, U., Kappos, L., Lechner-Scott, J., Brunnschweiler, H., Huber, S., Ammann, W., Plohm, A., Dellas, S., Maguire, R. P., Missimer, J., Radu, E. W., Steck, A., Leenders, K. L., 1997. Reduced glucose metabolism in the frontal cortex and basal ganglia of multiple sclerosis patients with fatigue: a 18F-fluorodeoxyglucose positron emission tomography study. *Neurology* 48, 1566-1571.

Rog, D. J., Nurmikko, T. J., Friede, T., Young, C. A., 2005. Randomized, controlled trial of cannabis-based medicine in central pain in multiple sclerosis. *Neurology*. 65, 812-819.

Rogers, J., Lubner, J., Styren, S. D., Civin, W. H., 1988. Expression of immune system-associated antigens by cells of the human central nervous system: relationship to the pathology of Alzheimer's disease. *Neurobiology of Aging* 9, 339-349.

Rosenberg, G. A., Appenzeller, O., 1988. Amantadine, fatigue, and multiple sclerosis. *Archives of Neurology* 45, 1104-1106.

Rossini, P. M., Pasqualetti, P., Pozzilli, C., Grasso, M. G., Millefiorini, E., Graceffa, A., Carlesimo, G. A., Zibellini, G., Caltagirone, C., 2001. Fatigue in progressive multiple sclerosis: results of a randomized, double-blind, placebo-controlled, crossover trial of oral 4-aminopyridine. *Multiple Sclerosis* 7, 354-358.

Rovaris, M., Confavreux, C., Furlan, R., Kappos, L., Comi, G., Filippi, M., 2006. Secondary progressive multiple sclerosis: current knowledge and future challenges. *The Lancet Neurology* 5, 343-354.

Roxburgh, R. H. S. R., Seaman, S. R., Masterman, T., Hensiek, A. E., Sawcer, S. J., Vukusic, S., Achiti, I., Confavreux, C., Coustans, M., le Page, E., Edan, G., McDonnell, G. V., Hawkins, S., Trojano, M., Liguori, M., Cocco, E., Marrosu, M. G., Tesser, F., Leone, M. A., Weber, A., Zipp, F., Mitterski, B., Epplen, J. T., Oturai, A., SÅ,rsen, P. S., Celius, E. G., Lara, N. T. I., Montalban, X., Villoslada, P., Silva, A. M., Marta, M., Leite, I., Dubois, B.,

- Rubio, J., Butzkueven, H., Kilpatrick, T., Mycko, M. P., Selmaj, K. W., Rio, M. E., SÁj, M., Salemi, G., Savettieri, G., Hillert, J., Compston, D. A. S., 2005. Multiple Sclerosis Severity Score. *Neurology* 64, 1144-1151.
- Rudick, R. A., Pace, A., Rani, M. R. S., Hyde, R., Panzara, M., Appachi, S., Shrock, J., Maurer, S. L., Calabresi, P. A., Confavreux, C., Galetta, S. L., Lublin, F. D., Radue, E. W., Ransohoff, R. M., 2009. Effect of statins on clinical and molecular responses to intramuscular interferon beta-1a. *Neurology* 72, 1989-1993.
- Rudick, R. A., Stuart, W. H., Calabresi, P. A., Confavreux, C., Galetta, S. L., Radue, E.-W., Lublin, F. D., Weinstock-Guttman, B., Wynn, D. R., Lynn, F., Panzara, M. A., Sandrock, A. W., 2006. Natalizumab plus Interferon Beta-1a for Relapsing Multiple Sclerosis. *New England Journal of Medicine* 354, 911-923.
- Rugino, T. A., Copley, T. C., 2001. Effects of Modafinil in Children With Attention-Deficit/Hyperactivity Disorder: An Open-Label Study. *Journal of the American Academy of Child & Adolescent Psychiatry* 40, 230-235.
- Sa, M. J., Sequeira, L., Rio, M. E., Thompson, E. J., 2005. Oligoclonal IgG bands in the cerebrospinal fluid of Portuguese patients with multiple sclerosis: Negative results indicate benign disease. *Arquivos de Neuro-Psiquiatria* 63, 375-379.
- Sabatine, M. S., Poh, K.-K., Mega, J. L., Shepard, J.-A. O., Stone, J. R., Frosch, M. P., 2007. A 31-Year-Old Woman with Rash, Fever, and Hypotension (Case study). *New England Journal of Medicine* 357, 2167-2178.
- Sadovnick, A. D., Ebers, G. C., Wilson, R. W., Paty, D. W., 1992. Life expectancy in patients attending multiple sclerosis clinics. *Neurology* 42, 991.
- Sadovnick, A. D., Eisen, K., Ebers, G. C., Paty, D. W., 1991. Cause of death in patients attending multiple sclerosis clinics. *Neurology* 41, 1193-1196.
- Sahraian, M. A., Radue, E. W., Eshaghi, A., Besliu, S., Minagar, A., 2012. Progressive multifocal leukoencephalopathy: a review of the neuroimaging features and differential diagnosis. *European Journal of Neurology* 19, 1060-1069.
- Saletu, B., Frey, R., Krupka, M., Anderer, P., Grunberger, J., Barbanoj, M. J., 1989. Differential effects of a new central adrenergic agonist - modafinil - and D-amphetamine on sleep and early morning behaviour in young healthy volunteers. *International Journal of Clinical Pharmacology Research* 9, 183-195.
- Samuels, E. R., Hou, R. H., Langley, R. W., Szabadi, E., Bradshaw, C. M., 2007. Modulation of the Acoustic Startle Response by the Level of Arousal: Comparison of Clonidine and Modafinil in Healthy Volunteers. *Neuropsychopharmacology* 32, 2405-2421.
- Samuels, E. R., Szabadi, E., 2008a. Functional Neuroanatomy of the Noradrenergic Locus Coeruleus: Its Roles in the Regulation of Arousal and Autonomic Function Part I: Principles of Functional Organisation. *Current Neuropharmacology* 6, 235-253.
- Samuels, E. R., Szabadi, E., 2008b. Functional neuroanatomy of the noradrenergic locus coeruleus: its roles in the regulation of arousal and autonomic function part II: physiological and pharmacological manipulations and pathological alterations of locus coeruleus activity in humans. *Current Neuropharmacology* 6, 254-285.
- Sanchez-Gonzalez, M. A., Garcia-Cabezas, M. A., Rico, B., Cavada, C., 2005. The primate thalamus is a key target for brain dopamine. *The Journal of Neuroscience* 25, 6076-6083.
- Sanya, E. O., Tutaj, M., Brown, C. M., Goel, N., Neundorfer, B., Hilz, M. J., 2005. Abnormal heart rate and blood pressure responses to baroreflex stimulation in multiple sclerosis. *Clinical Autonomic Research* 15, 213-218.

- Saper, C., Scammell, T., 2004. Modafinil: a drug in search of a mechanism. *Sleep* 27, 19-25.
- Scammell, T. E., Estabrooke, I. V., McCarthy, M. T., Chemelli, R. M., Yanagisawa, M., Miller, M. S., Saper, C. B., 2000. Hypothalamic Arousal Regions Are Activated during Modafinil-Induced Wakefulness. *The Journal of Neuroscience*. 20, 8620-8628.
- Schmaal, L., Joos, L., Koeleman, M., Veltman, D. J., van den Brink, W., Goudriaan, A. E., 2012. Effects of Modafinil on Neural Correlates of Response Inhibition in Alcohol-Dependent Patients. *Biological Psychiatry*, Available online: <http://www.sciencedirect.com/science/article/pii/S0006322312005872>, [Accessed: 7 September 2012].
- Schnoll, R. A., Wileyto, E. P., Pinto, A., Leone, F., Gariti, P., Siegel, S., Perkins, K. A., Dackis, C., Heitjan, D. F., Berrettini, W., Lerman, C., 2008. A placebo-controlled trial of modafinil for nicotine dependence. *Drug and Alcohol Dependence* 98, 86-93.
- Schwartz, C. E., Coulthard-Morris, L., Zeng, Q., 1996. Psychosocial correlates of fatigue in multiple sclerosis. *Archives of physical medicine and rehabilitation* 77, 165-170.
- Schwartz, J. E., Jandorf, L., Krupp, L. B., 1993. The measurement of fatigue: a new instrument. *Journal of Psychosomatic Research* 37, 753-762.
- Schwartz, J. R., Hirshkowitz, M., Erman, M. K., Schmidt-Nowara, W., 2003. Modafinil as adjunct therapy for daytime sleepiness in obstructive sleep apnea: a 12-week, open-label study. *Chest* 124, 2192-2199.
- Schwid, S. R., Covington, M., Segal, B. M., Goodman, A. D., 2002. Fatigue in multiple sclerosis: Current understanding and future directions. *Journal of Rehabilitation Research and Development* 39, 211-224.
- Schwid, S. R., Petrie, M. D., McDermott, M. P., Tierney, D. S., Mason, D. H., Goodman, A. D., 1997. Quantitative assessment of sustained-release 4-aminopyridine for symptomatic treatment of multiple sclerosis. *Neurology* 48, 817-821.
- Sena, A., Pedrosa, R., Graça Morais, M., 2003. Therapeutic potential of lovastatin in multiple sclerosis. *Journal of Neurology* 250, 754-755.
- Sendtner, M., Schmalbruch, H., Stockli, K. A., Carroll, P., Kreutzberg, G. W., Thoenen, H., 1992. Ciliary neurotrophic factor prevents degeneration of motor neurons in mouse mutant progressive motor neuronopathy. *Nature* 358, 502-504.
- Sevy, S., Rosenthal, M. H., Alvir, J., Meyer, S., Visweswarajah, H., Gunduz-Bruce, H., 2005. Double-blind, placebo-controlled study of modafinil for fatigue and cognition in schizophrenia patients treated with psychotropic medications. *Journal of Clinical Psychiatry* 66, 839-843.
- Sharma, K. R., Kent-Braun, J., Mynhier, M. A., Weiner, M. W., Miller, R. G., 1995. Evidence of an abnormal intramuscular component of fatigue in multiple sclerosis. *Muscle Nerve*. 8, 403-411.
- Sharrack, B., Hughes, R. A. C., 1999. The Guy's Neurological Disability Scale (GNDS): a new disability measure for multiple sclerosis. *Multiple Sclerosis* 5, 223-233.
- Sharrack, B., Hughes, R. A. C., Soudain, S., Dunn, G., 1999. The psychometric properties of clinical rating scales used in multiple sclerosis. *Brain* 122, 141-159.
- Shearer, J., Darke, S., Rodgers, C., Slade, T., Van Beek, I., Lewis, J., Brady, D., McKetin, R., Mattick, R. P., Wodak, A., 2009. A double-blind, placebo-controlled trial of modafinil (200 mg/day) for methamphetamine dependence. *Addiction* 104, 224-233.

- Sheean, G. L., Murray, N. M. F., Rothwell, J. C., Miller, D. H., Thompson, A. J., 1997. An electrophysiological study of the mechanism of fatigue in multiple sclerosis. *Brain* 120, 299-315.
- Siddiqui, S., Aleem, N. K., Baig, S., 2002. CSF Oligoclonal Bands in Multiple Sclerosis *Journal Of Pakistan Medical Association* 52, 351-353.
- Siemasko, K. F., Chong, A. S., Williams, J. W., Bremer, E. G., Finnegan, A., 1996. Regulation of B cell function by the immunosuppressive agent leflunomide. *Transplantation* 27, 635-642.
- Simon, P., Hemet, C., Ramassamy, C., Costentin, J., 1995. Non-amphetaminic mechanism of stimulant locomotor effect of modafinil in mice. *European Neuropsychopharmacology* 5, 509-514.
- Siritho, S., Freedman, M. S., 2009. The prognostic significance of cerebrospinal fluid in multiple sclerosis. *Journal of the Neurological Sciences* 279, 21-25.
- Smith, J. M., Misiak, H., 1976. Critical flicker frequency (CFF) and psychotropic drugs in normal human subjects-a review. *Psychopharmacology* 47, 175-182.
- Smith, K. J., Kapoor, R., Hall, S. M., Davies, M., 2001. Electrically active axons degenerate when exposed to nitric oxide. *Annals of Neurology* 49, 470-476.
- Sofuoglu, M., Waters, A. J., Mooney, M., 2008. Modafinil and nicotine interactions in abstinent smokers. *Human Psychopharmacology: Clinical and Experimental* 23, 21-30.
- Sorensen, P. S., Lycke, J., Erälinna, J. P., Edland, A., Wu, X., Frederiksen, J. L., Oturai, A., Malmeström, C., Stenager, E., Sellebjerg, F., Sondergaard, H. B., investigators., S. s., 2011. Simvastatin as add-on therapy to interferon beta-1a for relapsing-remitting multiple sclerosis (SIMCOMBIN study): a placebo-controlled randomised phase 4 trial. *The Lancet Neurology* 10, 691-701.
- Sorensen, P. S., Mellgren, S. I., Svenningsson, A., Elovaara, I., Frederiksen, J. L., Beiske, A. G., Myhr, K.-M., Søgaaard, L. V., Olsen, I. C., Sandberg-Wollheim, M., 2009. NORdic trial of oral Methylprednisolone as add-on therapy to Interferon beta-1a for treatment of relapsing-remitting Multiple Sclerosis (NORMIMS study): a randomised, placebo-controlled trial. *The Lancet Neurology* 8, 519-529.
- Spathis, A., Dhillan, R., Booden, D., Forbes, K., Vrotsou, K., Fife, K., 2009. Modafinil for the treatment of fatigue in lung cancer: a pilot study. *Palliative Medicine* 23, 325-331.
- Specogna, I., Casagrande, F., Lorusso, A., Catalan, M., Gorian, A., Zugna, L., Longo, R., Zorzon, M., Naccarato, M., Pizzolato, G., Ukmar, M., Cova, M. A., 2012. Functional MRI during the execution of a motor task in patients with multiple sclerosis and fatigue. *La radiologia medica* 117, 1398-1407.
- Spence, S. A., Green, R. D., Wilkinson, I. D., Hunter, M. D., 2005. Modafinil modulates anterior cingulate function in chronic schizophrenia. *British Journal of Psychiatry* 187, 55-61.
- Stanislaus, R., Singh, A. K., Singh, I., 2001. Lovastatin treatment decreases mononuclear cell infiltration into the CNS of Lewis rats with experimental allergic encephalomyelitis. *Journal of Neuroscience Research* 66, 155-162.
- Stankoff, B., Waubant, E., Confavreux, C., Edan, G., Debouverie, M., Rumbach, L., Moreau, T., Pelletier, J., Lubetzki, C., Clanet, M., French Modafinil Study, G., 2005. Modafinil for fatigue in MS: A randomized placebo-controlled double-blind study. *Neurology* 64, 1139-1143.

Steens, A., de Vries, A., Hemmen, J., Heersema, T., Heerings, M., Maurits, N., Zijdewind, I., 2012. Fatigue Perceived by Multiple Sclerosis Patients Is Associated With Muscle Fatigue. *Neurorehabilitation and Neural Repair* 26, 48-57.

Stendahl-Brodin, L., Link, H., 1980. Relation between benign course of multiple sclerosis and low-grade humoral immune response in cerebrospinal fluid. *Journal of Neurology, Neurosurgery, and Psychiatry* 43, 102–105.

Stocking, E. M., Letavic, M. A., 2008. Histamine H3 Antagonists as Wake-Promoting and Pro-Cognitive Agents. *Current Topics in Medicinal Chemistry* 8, 988-1002.

Stone, E. A., Cotecchia, S., Lin, Y., Quartermain, D., 2002. Role of brain alpha 1B-adrenoceptors in modafinil-induced behavioral activity. *Synapse* 46, 269-270.

Swanson, J. M., Greenhill, L. L., Lopez, F. A., Sedillo, A., Earl, C. Q., Jiang, J. G., 2006. Modafinil film-coated tablets in children and adolescents with attention-deficit/hyperactivity disorder: results of a randomized, double-blind, placebo-controlled, fixed-dose study followed by abrupt discontinuation. *Journal of Clinical Psychiatry* 67, 137-147.

Szabadi, E., 2006. Drugs for sleep disorders: mechanisms and therapeutic prospects. *British Journal of Clinical Pharmacology* 61, 761-766.

Szabadi, E., Samuels, E. R., 2008. Stimulants: mechanisms and therapeutic prospects. In: Pandi-Perumal, S.R., Verster, J.C., Monti, J.M., Lader, M., Langer, S.Z. (Eds.), *Sleep Disorders: Diagnostics and Therapeutics*. Informa Healthcare UK, London,, 281-294.

t Hart, B. A., Gran, B., Weissert, R., 2011. EAE: imperfect but useful models of multiple sclerosis. *Trends in Molecular Medicine* 17, 119-125.

Talairach, J., Tournoux, P., 1988. *Co-Planar Stereotactic Atlas of the Human Brain*. . Thieme, Stuttgart/New York.

Talbot, K., Stradling, J., Crosby, J., Hilton-Jones, D., 2003. Reduction in excess daytime sleepiness by modafinil in patients with myotonic dystrophy. *Neuromuscular Disorders* 13, 357-364.

Tan, E. M., Feltkamp, T. E. W., Smolen, J. S., Butcher, B., Dawkins, R., Fritzler, M. J., Gordon, T., Hardin, J. A., Kalden, J. R., Lahita, R. G., Maini, R. N., McDougal, J. S., Rothfield, N. F., Smeenk, R. J., Takasaki, Y., Wiik, A., Wilson, M. R., Koziol, J. A., 1997. Range of antinuclear antibodies in "healthy" individuals. *Arthritis and Rheumatism* 40, 1601-1611.

Tanaka, M., Sadato, N., Okada, T., Mizuno, K., Sasabe, T., Tanabe, H., Saito, D., Onoe, H., Kuratsune, H., Watanabe, Y., 2006. Reduced responsiveness is an essential feature of chronic fatigue syndrome: A fMRI study. *BioMedCentral Neurology* 6, 9.

Taneja, I., Diedrich, A., Black, B. K., Byrne, D. W., Paranjape, S. Y., Robertson, D., 2005. Modafinil Elicits Sympathomedullary Activation. *Hypertension* 45, 612-618.

Tanganelli, S., Ferraro, L., Bianchi, C., Fuxe, K., 1994. 6-hydroxy-dopamine treatment counteracts the reduction of cortical GABA release produced by the vigilance promoting drug modafinil in the awake freely moving guinea-pig. *Neuroscience Letters* 171, 201-204.

Tanganelli, S., Fuxe, K., Ferraro, L., Janson, A. M., Bianchi, C., 1992. Inhibitory effects of the psychoactive drug modafinil on gamma-aminobutyric acid outflow from the cerebral cortex of the awake freely moving guinea-pig. Possible involvement of 5-hydroxytryptamine mechanisms. *Naunyn-Schmiedeberg's Archives of Pharmacology* 345, 461-465.



Tanganelli, S., Perez de la Mora, M., Ferraro, L., Mendez-Franco, J., Beani, L., Rambert, F. A., 1995. Modafinil and cortical gamma-aminobutyric acid outflow. Modulation by 5-hydroxytryptamine neurotoxins. *European Journal of Pharmacology* 273, 63-71.

Tartaglia, M. C., Narayanan, S., Arnold, D. L., 2008. Mental fatigue alters the pattern and increases the volume of cerebral activation required for a motor task in multiple sclerosis patients with fatigue. *European Journal of Neurology* 15, 413-419.

Tartaglia, M. C., Narayanan, S., Francis, S. J., Santos, A. C., De Stefano, N., Lapierre, Y., Arnold, D. L., 2004. The Relationship Between Diffuse Axonal Damage and Fatigue in Multiple Sclerosis. *Archives of Neurology* 61, 201-207.

Taylor, F. B., Russo, J., 2000. Efficacy of modafinil compared to dextroamphetamine for the treatment of attention deficit hyperactivity disorder in adults. *Journal of Child and Adolescent Psychopharmacology* 10, 311-320.

Tedeschi, G., Dinacci, D., Lavorgna, L., Prinster, A., Savettieri, G., Quattrone, A., Livrea, P., Messina, C., Reggio, A., Servillo, G., Bresciamorra, V., Orefice, G., Paciello, M., Brunetti, A., Paolillo, A., Coniglio, G., Bonavita, S., Di Costanzo, A., Bellacosa, A., Valentino, P., Quarantelli, M., Patti, F., Salemi, G., Cammarata, E., Simone, I., Salvatore, M., Bonavita, V., Alfano, B., 2007. Correlation between fatigue and brain atrophy and lesion load in multiple sclerosis patients independent of disability. *Journal of the Neurological Sciences* 263, 15-19.

Teitelbaum, D., Meshorer, A., Hirshfeld, T., Arnon, R., Sela, M., 1971. Suppression of experimental allergic encephalomyelitis by a synthetic polypeptide. *European Journal of Immunology* 1, 242-248.

Télez, N., Alonso, J., Río, J., Tintoré, M., Nos, C., Montalban, X., Rovira, A., 2008. The basal ganglia: a substrate for fatigue in multiple sclerosis. *Neuroradiology* 50, 17-23.

Télez, N., Comabella, M., Julià, E., Río, J., Tintoré, M., Brieva, L., Nos, C., Montalban, X., 2006. Fatigue in progressive multiple sclerosis is associated with low levels of dehydroepiandrosterone. *Multiple Sclerosis* 12, 487-494.

Teuscher, C., Subramanian, M., Noubade, R., Gao, J. F., Offner, H., Zachary, J. F., Blankenhorn, E. P., 2007. Central histamine H3 receptor signaling negatively regulates susceptibility to autoimmune inflammatory disease of the CNS. *Proceedings of the National Academy of Sciences* 104, 10146-10151.

The Ifnb Multiple Sclerosis Study Group, 1993. Interferon beta-1b is effective in relapsing-emitting multiple sclerosis: I. Clinical results of a multicenter, randomized, double-blind, placebo-controlled trial. *Neurology* 43, 655.

Thickbroom, G., Sacco, P., Faulkner, D., Kermodé, A., Mastaglia, F., 2008. Enhanced corticomotor excitability with dynamic fatiguing exercise of the lower limb in multiple sclerosis. *Journal of Neurology* 255, 1001-1005.

Touret, M., Sallanon-Moulin, M., Fages, C., Roudier, V., Didier-Bazes, M., Roussel, B., Tardy, M., Jouvet, M., 1994. Effects of modafinil-induced wakefulness on glutamine synthetase regulation in the rat brain. *Molecular Brain Research* 26, 123-128.

Trapp, B. D., Nave, K. A., 2008. Multiple sclerosis: An immune or neurodegenerative disorder? , *Annual Review of Neuroscience* 31, 247-269.

Trapp, B. D., Peterson, J., Ransohoff, R. M., Rudick, R., Mörk, S., Bö, L., 1998. Axonal Transection in the Lesions of Multiple Sclerosis. *New England Journal of Medicine* 338, 278-285.

Trapp, B. D., Stys, P. K., 2009. Virtual hypoxia and chronic necrosis of demyelinated axons in multiple sclerosis. *Lancet Neurology* 8, 280-291.

- Trojano, M., Logroscino, G. C., Picicchio, L., Rosato, A., Bordo, B., Citterio, A., Amato, M. P., Livrea, P., 1987. The Multiple Sclerosis Cooperative Etiological Study in Italy: preliminary analysis of CSF findings. *Italian journal of neurological sciences Suppl* 6, 71-76.
- Trojano, M., Pellegrini, F., Fuiani, A., Paolicelli, D., Zipoli, V., Zimatore, G. B., Di Monte, E., Portaccio, E., Lepore, V., Livrea, P., Amato, M. P., 2007. New natural history of interferon- $\beta$ -treated relapsing multiple sclerosis. *Annals of Neurology* 61, 300-306.
- Turkeltaub, P. E., F., G., Eden, G. F., M., K., Jones, K. M., Zeffiro, T. A., 2002. Meta-Analysis of the Functional Neuroanatomy of Single-Word Reading: Method and Validation. *NeuroImage* 16, 765-780.
- Turner, D. C., Clark, L., Dowson, J., Robbins, T. W., Sahakian, B. J., 2004a. Modafinil improves cognition and response inhibition in adult attention-deficit/hyperactivity disorder. *Biological Psychiatry* 55, 1031-1040.
- Turner, D. C., Clark, L., Pomarol-Clotet, E., McKenna, P., Robbins, T. W., Sahakian, B. J., 2004b. Modafinil improves cognition and attentional set shifting in patients with chronic schizophrenia. *Neuropsychopharmacology* 29, 1363-1373.
- Turner, D. C., Robbins, T. W., Clark, L., Aron, A. R., Dowson, J., Sahakian, B. J., 2003. Cognitive enhancing effects of modafinil in healthy volunteers. *Psychopharmacology* 165, 260-269.
- Uccelli, A., Zappia, E., Benvenuto, F., Frassoni, F., Mancardi, G., 2006. Stem cells in inflammatory demyelinating disorders: a dual role for immunosuppression and neuroprotection. *Expert Opinion on Biological Therapy* 6, 17-22.
- Ueki, A., Rosen, L., Andbjør, B., Agnati, L. F., Hallstrom, A., Gojny, M., Tanganelli, S., Ungerstedt, U., Fuxe, K., 1993a. Evidence for a preventive action of the vigilance-promoting drug modafinil against striatal ischemic injury induced by endothelin-1 in the rat. *Experimental Brain Research*. 96, 89-99.
- Ueki, A., Rosen, L., Andbjør, B., Finnman, U., Altamimi, U., Janson, A. M., Goldstein, M., Agnati, L., F., , Fuxe, K., 1993b. The vigilance-promoting drug modafinil counteracts the reduction of tyrosine hydroxylase immunoreactivity and of dopamine stores in nigrostriatal dopamine neurons in the male rat after a partial transection of the dopamine pathway. *Experimental Brain Research* 93, 259 -270.
- Umanoff, D. F., 2005. Trial of Modafinil for Cocaine Dependence. *Neuropsychopharmacology* 30, 2298-2298.
- US Modafinil in Narcolepsy Multicenter Study, G., 1998. Randomized trial of modafinil for the treatment of pathological somnolence in narcolepsy. *Annals of Neurology* 43, 88-97.
- Valko, P. O., Bassetti, C. L., Bloch, K. E., Held, U., Baumann, C. R., 2008. Validation of the fatigue severity scale in a Swiss cohort. *Sleep* 31, 1601-1607.
- Van der Walt, A., Butzkueven, H., Kolbe, S., Marriott, M., Alexandrou, E., Gresle, M., Egan, G., Kilpatrick, T., 2010. Neuroprotection in multiple sclerosis: A therapeutic challenge for the next decade. *Pharmacology & Therapeutics* 126, 82-93.
- van der Werf, S. P., Jongen, P. J., Lycklama a Nijeholt, G. J., Barkhof, F., Hommes, O. R., Bleijenberg, G., 1998. Fatigue in multiple sclerosis: interrelations between fatigue complaints, cerebral MRI abnormalities and neurological disability. *Journal of the Neurological Sciences* 160, 164-170.

- van Kessel, K., Moss-Morris, R., Willoughby, E., Chalder, T., Johnson, M. H., Robinson, E., 2008. A Randomized Controlled Trial of Cognitive Behavior Therapy for Multiple Sclerosis Fatigue. *Psychosomatic Medicine* 70, 205-213.
- van Vliet, S. A. M., Vanwersch, R. A. P., Jongsma, M. J., van der Gugten, J., Olivier, B., Philippens, I. H. C. H. M., 2006. Neuroprotective effects of modafinil in a marmoset Parkinson model: behavioral and neurochemical aspects. *Behavioural Pharmacology* 17, 453-462.
- Vasconcelos, O., Prokhorenko, O., Salajegheh, M., al., e., 2007. Modafinil for treatment of fatigue in post-polio syndrome: a randomized controlled trial. *Neurology* 68, 1680-1686
- Vilisaar, J., Wilson, M., Niepel, G., Blumhardt, L. D., Constantinescu, C. S., 2005. A comparative audit of anticardiolipin antibodies in oligoclonal band negative and positive multiple sclerosis. *Multiple Sclerosis* 11, 378-380.
- Vincenti, F., Kirkman, R., Light, S., Bumgardner, G., Pescovitz, M., Halloran, P., Neylan, J., Wilkinson, A., Ekberg, H., Gaston, R., Backman, L., Burdick, J., 1998. Interleukin-2-Receptor Blockade with Daclizumab to Prevent Acute Rejection in Renal Transplantation. *New England Journal of Medicine* 338, 161-165.
- Vita, G., Fazio, M. C., Milone, S., Blandino, A., Salvi, L., Messina, C., 1993. Cardiovascular autonomic dysfunction in multiple sclerosis is likely related to brainstem lesions. *Journal of the Neurological Sciences* 75, 82-86.
- Volkow, N. D., Fowler, J. S., Logan, J., Alexoff, D., Zhu, W., Telang, F., Wang, G., Jayne, M., Hooker, J. M., Wong, C., Hubbard, B., Carter, P., Warner, D., King, P., Shea, C., Xu, Y., Muench, L., Apelskog-Torres, K., 2009. Effects of Modafinil on Dopamine and Dopamine Transporters in the Male Human Brain. *JAMA: The Journal of the American Medical Association* 301, 1148-1154.
- Vollmer, T., Key, L., Durkalski, V., Tyor, W., Corboy, J., Markovic-Plese, S., Preiningerova, J., Rizzo, M., Singh, I., 2004. Oral simvastatin treatment in relapsing-remitting multiple sclerosis. *The Lancet* 363, 1607-1608.
- Wager, D., Smith, E., 2003. Neuroimaging studies of working memory. *Cognitive, Affective, & Behavioral Neuroscience* 3, 255-274.
- Wallin, B. G., 1992. Intraneural recordings of normal and abnormal sympathetic activity in man. In: Bannister, R., Mathias, C.J. (Eds.), *Autonomic Failure. A Textbook of Clinical Disorders of the Autonomic Nervous System*, third ed. Oxford University Press, Oxford, , pp. 359-377.
- Wallin, M. T., Page, W. F., Kurtzke, J. F., 2000. Epidemiology of multiple sclerosis in US veterans VIII. Long-term survival after onset of multiple sclerosis. *Brain* 123, 1677-1687.
- Wallstrom, E., Diener, P., Ljungdahl, Å., Khademi, M., Nilsson, C. G., Olsson, T., 1996. Memantine abrogates neurological deficits, but not CNS inflammation, in Lewis rat experimental autoimmune encephalomyelitis. *Journal of the Neurological Sciences* 137, 89-96.
- Walsh, J. K., Randazzo, A. C., Stone, K. L., Schweitzer, P. K., 2004. Modafinil improves alertness, vigilance, and executive function during simulated night shifts. *Sleep* 27, 434-439.
- Wang, J., Xiao, Y., Luo, M., Luo, H., 2011. Statins for multiple sclerosis. *Cochrane Database of Systematic Reviews*. available online: <http://onlinelibrary.wiley.com/doi/10.1002/14651858.CD008386.pub3/full>. [Accessed November 2012].

- Watanabe, T., Masuyama, J.-i., Sohma, Y., Inazawa, H., Horie, K., Kojima, K., Uemura, Y., Aoki, Y., Kaga, S., Minota, S., Tanaka, T., Yamaguchi, Y., Kobayashi, T., Serizawa, I., 2006. CD52 is a novel costimulatory molecule for induction of CD4+ regulatory T cells. *Clinical Immunology* 120, 247-259.
- Waxman, S. G., 2001. Acquired channelopathies in nerve injury and MS. *Neurology* 56, 1621-1627.
- Webster, L., Andrews, M., Stoddard, G., 2003. Modafinil treatment of opioid-induced sedation. *Pain Med* 4, 135-140.
- Weinshenker, B. G., 2001. Plasma exchange for severe attacks of inflammatory demyelinating diseases of the central nervous system. *Journal of Clinical Apheresis* 16, 39-42.
- Weinshenker, B. G., Penman, M., Bass, B., Ebers, G. C., Rice, G. P., 1992. A double-blind, randomized, crossover trial of pemoline in fatigue associated with multiple sclerosis. *Neurology* 42, 1468-1471.
- Weinshenker, B. G., Wingerchuk, D. M., Vukusic, S., Linbo, L., Pittock, S. J., Lucchinetti, C. F., Lennon, V. A., 2006. Neuromyelitis optica IgG predicts relapse after longitudinally extensive transverse myelitis. *Annals of Neurology* 59, 566-569.
- Wesensten, N. J., Belenky, G., Kautz, M. A., Thorne, D. R., Reichardt, R. M., Balkin, T. J., 2002. Maintaining alertness and performance during sleep deprivation: modafinil versus caffeine. *Psychopharmacology* 159, 238-247.
- Wesensten, N. J., Killgore, W. D., Balkin, T. J., 2005. Performance and alertness effects of caffeine, dextroamphetamine, and modafinil during sleep deprivation. *Journal of Sleep Research* 14, 255-266.
- Wilken, J. A., Sullivan, C., Wallin, M., Rogers, C., Kane, R. L., Rossman, H., Lawson, S., Simsarian, J., Saunders, C., Quig, M. E., 2008. Treatment of multiple Sclerosis-related cognitive problems with adjunctive modafinil. Rationale and preliminary supportive data. *International Journal of MS Care* 10, 1-10.
- Wilkins, A., Compston, A., 2005. Trophic factors attenuate nitric oxide mediated neuronal and axonal injury in vitro: roles and interactions of mitogen-activated protein kinase signalling pathways. *Journal of Neurochemistry* 92, 1487-1496.
- Williams, K., Ulvestad, E., Hickey, W., 1994. Immunology of multiple sclerosis. *Journal of Clinical Neuroscience*. 2, 229-245.
- Willie, J. T., Renthal, W., Chemelli, R. M., Miller, M. S., Scammell, T. E., Yanagisawa, M., 2005. Modafinil more effectively induces wakefulness in orexin-null mice than in wild-type littermates. *Neuroscience* 130, 983-995.
- Wingerchuk, D. M., Lennon, V. A., Pittock, S. J., Lucchinetti, C. F., Weinshenker, B. G., 2006. Revised diagnostic criteria for neuromyelitis optica. *Neurology* 66, 1485-1489.
- Wintzen, A. R., Lammers, G. J., van Dijk, J. G., 2007. Does modafinil enhance activity of patients with myotonic dystrophy? A double-blind placebo-controlled crossover study. *Journal of Neurology* 254, 26-28.
- Wisor, J. P., Nishino, S., Sora, I., Uhl, G. H., Mignot, E., Edgar, D. M., 2001. Dopaminergic role in stimulant-induced wakefulness. *Journal of Neuroscience* 21, 1787-1794.
- Wolf, S. D., Dittel, B. N., Hardardottir, F., Janeway, C. A., 1996. Experimental autoimmune encephalomyelitis induction in genetically B cell-deficient mice. *Journal of Experimental Medicine* 184, 2271-2278.

Wong, Y. N., Simcoe, D., Hartman, L. N., Laughton, W. B., King, S. P., McCormick, G. C., 1999. A double-blind, placebo-controlled, ascending-dose evaluation of the pharmacokinetics and tolerability of modafinil tablets in healthy male volunteers. *Journal of Clinical Pharmacology* 39, 30-40.

Wucherpfennig, K. W., Strominger, J. L., 1995. Selective binding of self peptides to disease-associated major histocompatibility complex (MHC) molecules - a mechanism for MHC-linked susceptibility to human autoimmune-diseases. *Journal of Experimental Medicine* 181, 1597-1601.

Wynn, D., Kaufman, M., Montalban, X., Vollmer, T., Simon, J., Elkins, J., O'Neill, G., Neyer, L., Sheridan, J., Wang, C., Fong, A., Rose, J. W., 2010. Daclizumab in active relapsing multiple sclerosis (CHOICE study): a phase 2, randomised, double-blind, placebo-controlled, add-on trial with interferon beta. *The Lancet Neurology* 9, 381-390.

Xiao, Y. L., Fu, J. M., Dong, Z., Yang, J. Q., Zeng, F. X., Zhu, L. X., He, B. C., 2004. Neuroprotective mechanism of modafinil on Parkinson disease induced by 1-methyl-4-phenyl-1,2,3,6-tetrahydropyridine. *Acta Pharmacologica Sinica* 25, 301-305.

Yaldizli, Ö., Glassl, S., Sturm, D., Papadopoulou, A., Gass, A., Tettenborn, B., Putzki, N., 2011. Fatigue and progression of corpus callosum atrophy in multiple sclerosis. *Journal of Neurology* 258, 2199-2205.

Yang, J., Rostami, A., Zhang, G.-X., 2009. Cellular remyelinating therapy in multiple sclerosis. *Journal of the Neurological Sciences* 276, 1-5.

Yang, J. S., Xu, L. Y., Xiao, B. G., Hedlund, G., Link, H., 2004. Laquinimod (ABR-215062) suppresses the development of experimental autoimmune encephalomyelitis, modulates the Th1/Th2 balance and induces the Th3 cytokine TGF- $\beta$ 2 in Lewis rats. *Journal of Neuroimmunology* 156, 3-9.

Yao, D. L., Liu, X., Hudson, L. D., Webster, H. D. F., 1996. Insulin-like growth factor-I given subcutaneously reduces clinical deficits, decreases lesion severity and upregulates synthesis of myelin proteins in experimental autoimmune encephalomyelitis. *Life Sciences* 58, 1301-1306.

Yoshida, K., McCormack, S., España, R. A., Crocker, A., Scammell, T. E., 2006. Afferents to the orexin neurons of the rat brain. *The Journal of Comparative Neurology* 494, 845-861.

Yoss, R. E., Moyer, N. J., Hollenhorst, R. W., 1970. Pupil size and spontaneous pupillary waves associated with alertness, drowsiness, and sleep. *Neurology* 20, 545-554.

Youssef, S., Ståve, O., Patarroyo, J. O., Ruiz, P. J., Radosevich, J. L., Mi Hur, E., Bravo, M., Mitchell, D. J., Sobel, R. A., Stelman, L., Zamvil, S. S., 2002. The HMG-CoA reductase inhibitor, atorvastatin, promotes a Th2 bias and reverses paralysis in central nervous system autoimmune disease. *Nature* 420, 78-84.

Yudkin, P. L., Ellison, G. W., Ghezzi, A., Goodkin, D. E., Hughes, R. A. C., McPherson, K., Mertin, J., Milanese, C., 1991. Overview of azathioprine treatment in multiple sclerosis. *The Lancet* 338, 1051-1055.

Zajicek, J., Fox, P., Sanders, H., Wright, D., Vickery, J., Nunn, A., Thompson, A., 2003. Cannabinoids for treatment of spasticity and other symptoms related to multiple sclerosis (CAMS study): multicentre randomised placebo-controlled trial. *The Lancet* 362, 1517-1526.

Zajicek, J., Ingram, W., Vickery, J., Creanor, S., Wright, D., Hobart, J., 2010. Patient-orientated longitudinal study of multiple sclerosis in south west England (The South West Impact of Multiple Sclerosis Project, SWIMS) 1: protocol and baseline characteristics of cohort. *BioMedCentral Neurology* 10, 88.

Zajicek, J. P., Hobart, J. C., Slade, A., Barnes, D., Mattison, P. G., on behalf of the, M. R. G., 2012. Multiple Sclerosis and Extract of Cannabis: results of the MUSEC trial. *Journal of Neurology, Neurosurgery & Psychiatry* 83, 1125-1132.

Zappia, E., Casazza, S., Pedemonte, E., Benvenuto, F., Bonanni, I., Gerdoni, E., Giunti, D., Ceravolo, A., Cazzanti, F., Frassoni, F., Mancardi, G., Uccelli, A., 2005. Mesenchymal stem cells ameliorate experimental autoimmune encephalomyelitis inducing T-cell anergy. *Blood* 106, 1755-1761.

Zeman, A. Z., Kidd, D., McLean, B. N., Kelly, M. A., Francis, D. A., Miller, D. H., E., K. B., Rudge, P., Thompson, E. J., McDonald, W. I., 1996. A study of oligoclonal band negative multiple sclerosis. *Journal of Neurology, Neurosurgery and Psychiatry* 60, 27-30.

Zeng, B. Y., Smith, L. A., Pearce, R. K. B., Tel, B., Chancharme, L., Moachon, G., Jenner, P., 2004. Modafinil prevents the MPTP-induced increase in GABAA receptor binding in the internal globus pallidus of MPTP-treated common marmosets. *Neuroscience Letters* 354, 6-9.

Zhang, J., Li, Y., Chen, J., Cui, Y., Lu, M., Elias, S. B., Mitchell, J. B., Hammill, L., Vanguri, P., Chopp, M., 2005. Human bone marrow stromal cell treatment improves neurological functional recovery in EAE mice. *Experimental Neurology* 195, 16-26.

Zifko, U. A., 2004. Management of Fatigue in Patients with Multiple Sclerosis. *Drugs* 64, 1295-1304.

Zifko, U. A., Rupp, M., Schwarz, S., Zipko, H. T., Maida, E. M., 2002. Modafinil in treatment of fatigue in multiple sclerosis - Results of an open-label study. *Journal of Neurology* 249, 983-987.

Zolkowska, D., Jain, R., Rothman, R. B., Partilla, J. S., Roth, B. L., Setola, V., Prisinzano, T. E., Baumann, M. H., 2009. Evidence for the Involvement of Dopamine Transporters in Behavioral Stimulant Effects of Modafinil. *Journal of Pharmacology and Experimental Therapeutics* 329, 738-746.

Zoukos, Y., Kidd, D., Woodroffe, M. N., Kendall, B. E., Thompson, A. J., Cuzner, M. L., 1994. Increased expression of high affinity IL-2 receptors and beta-adrenoceptors on peripheral blood mononuclear cells is associated with clinical and MRI activity in multiple sclerosis. *Brain* 117, 307-315.



## **APPENDICES**



## Appendix 1 Ethics approval

The study described in chapter three was performed on healthy volunteers and patients following the approval of the Nottingham Research Ethics Committee. Reference numbers NS100201 and NS090102. This study also approved by the Medicine Control Agency. Reference number: MF 8000/12346.

## Appendix 2 McDonald criteria for diagnosis of multiple sclerosis (2001). Source (McDonald et al., 2001).

Clinical Presentation	Additional Data Needed
* 2 or more attacks (relapses) * 2 or more objective clinical lesions	None; clinical evidence will suffice (additional evidence desirable but must be consistent with MS)
* 2 or more attacks * 1 objective clinical lesion	Dissemination in space, demonstrated by: * MRI * or a positive CSF and 2 or more MRI lesions consistent with MS * or further clinical attack involving different site
* 1 attack * 2 or more objective clinical lesions	Dissemination in time, demonstrated by: * MRI * or second clinical attack
* 1 attack * 1 objective clinical lesion (monosymptomatic presentation)	Dissemination in space demonstrated by: * MRI * or positive CSF and 2 or more MRI lesions consistent with MS and Dissemination in time demonstrated by: * MRI * or second clinical attack
Insidious neurological progression suggestive of MS (primary progressive MS)	One year of disease progression (retrospectively or prospectively determined) and  Two of the following: a. Positive brain MRI (nine T2 lesions or four or more T2 lesions with positive VEP) b. Positive spinal cord MRI (two focal T2 lesions) c. Positive CSF

**Appendix 3 Expanded disability status scale (EDSS).** Source (Kurtzke, 1983)

score	Description
1.0	No disability, minimal signs in one FS
1.5	No disability, minimal signs in more than one FS
2.0	Minimal disability in one FS
2.5	Mild disability in one FS or minimal disability in two FS
3.0	Moderate disability in one FS, or mild disability in three or four FS. No impairment to walking
3.5	Moderate disability in one FS and more than minimal disability in several others. No impairment to walking
4.0	Significant disability but self-sufficient and up and about some 12 hours a day. Able to walk without aid or rest for 500m
4.5	Significant disability but up and about much of the day, able to work a full day, may otherwise have some limitation of full activity or require minimal assistance. Able to walk without aid or rest for 300m
5.0	Disability severe enough to impair full daily activities and ability to work a full day without special provisions. Able to walk without aid or rest for 200m
5.5	Disability severe enough to preclude full daily activities. Able to walk without aid or rest for 100m
6.0	Requires a walking aid - cane, crutch, etc - to walk about 100m with or without resting
6.5	Requires two walking aids - pair of canes, crutches, etc - to walk about 20m without resting
7.0	Unable to walk beyond approximately 5m even with aid. Essentially restricted to wheelchair; though wheels self in standard wheelchair and transfers alone. Up and about in wheelchair some 12 hours a day
7.5	Unable to take more than a few steps. Restricted to wheelchair and may need aid in transferring. Can wheel self but cannot carry on in standard wheelchair for a full day and may require a motorised wheelchair
8.0	Essentially restricted to bed or chair or pushed in wheelchair. May be out of bed itself much of the day. Retains many self-care functions. Generally has effective use of arms
8.5	Essentially restricted to bed much of day. Has some effective use of arms retains some self-care functions
9.0	Confined to bed. Can still communicate and eat
9.5	Confined to bed and totally dependent. Unable to communicate effectively or eat/swallow
10.0	Death due to MS

**Appendix 4 The 2005 revisions to the McDonald diagnostic criteria for multiple sclerosis** (Polman et al., 2005).

Clinical Presentation	Additional Data Needed for MS Diagnosis
Two or more attacks <sup>a</sup> ; objective clinical evidence of two or more lesions	None <sup>b</sup>
Two or more attacks <sup>a</sup> ; objective clinical evidence of one lesion	Dissemination in space, demonstrated by:
	●MRI <sup>c</sup> <i>or</i>
	●Two or more MRI-detected lesions consistent with MS plus positive CSF <sup>d</sup> <i>or</i>
	●Await further clinical attack <sup>a</sup> implicating a different site
One attack <sup>a</sup> ; objective clinical evidence of two or more lesions	Dissemination in time, demonstrated by:
	●MRI <sup>e</sup> <i>or</i>
	●Second clinical attack <sup>a</sup>
One attack <sup>a</sup> ; objective clinical evidence of one lesion (monosymptomatic presentation; clinically isolated syndrome)	Dissemination in space, demonstrated by:
	●MRI <sup>c</sup> <i>or</i>
	●Two or more MRI-detected lesions consistent with MS plus positive CSF <sup>d</sup> <i>and</i>
	Dissemination in time, demonstrated by:
	●MRI <sup>e</sup> <i>or</i>
	●Second clinical attack <sup>a</sup>
Insidious neurological progression suggestive of MS	One year of disease progression (retrospectively or prospectively determined) <i>and</i>
	Two of the following:
	a. Positive brain MRI (nine T2 lesions or four or more T2 lesions with positive VEP) <sup>f</sup>
	b. Positive spinal cord MRI (two focal T2 lesions)
	One year of disease progression (retrospectively or prospectively determined) <i>and</i>

If criteria indicated are fulfilled and there is no better explanation for the clinical presentation, the diagnosis is MS; if suspicious, but the criteria are not completely met, the diagnosis is “possible MS”; if another diagnosis arises during the evaluation that better explains the entire clinical presentation, then the diagnosis is “not MS.”

a An attack is defined as an episode of neurological disturbance for which causative lesions are likely to be inflammatory and demyelinating in nature. There should be subjective report (backed up by objective findings) or objective observation that the event lasts for at least 24 hours (McDonald et al., 2001).

B No additional tests are required; however, if tests (MRI, CSF) are undertaken and are *negative*, extreme caution needs to be taken before making a diagnosis of MS. Alternative diagnoses must be considered. There must be no better explanation for the clinical picture and some objective evidence to support a diagnosis of MS.

C MRI demonstration of space dissemination must fulfil the criteria derived from Barkhof and colleagues (Barkhof et al., 1997; Tintoré et al., 2000).

d Positive CSF determined by oligoclonal bands detected by established methods (isoelectric focusing) different from any such bands in serum, or by an increased IgG index (Andersson et al., 1994; Freedman Ms and et al., 2005; Link and Tibbling, 1997).

e MRI demonstration of time dissemination must fulfil the criteria in appendix 5.

f Abnormal VEP of the type seen in MS

**Appendix 5 Magnetic resonance imaging criteria to demonstrate dissemination of lesions in time** (Polman et al., 2005).

Original McDonald Criterion	2005 Revisions
<p>1. If a first scan occurs 3 months or more after the onset of the clinical event, the presence of a gadolinium-enhancing lesion is sufficient to demonstrate dissemination in time, provided that it is not at the site implicated in the original clinical event. If there is no enhancing lesion at this time, a follow-up scan is required. The timing of this follow-up scan is not crucial, but 3 months is recommended. A new T2- or gadolinium-enhancing lesion at this time then fulfils the criterion for dissemination in time.</p> <p>2. If the first scan is performed less than 3 months after the onset of the clinical event, a second scan done 3 months or longer after the clinical event showing a new gadolinium-enhancing lesion provides sufficient evidence for dissemination in time. However, if no enhancing lesion is seen at this second scan, a further scan not less than 3 months after the first scan that shows a new T2 lesion or an enhancing lesion will suffice.</p>	<p>1. There are two ways to show dissemination in time using imaging:</p> <p>a. Detection of gadolinium enhancement at least 3 months after the onset of the initial clinical event, if not at the site corresponding to the initial event.</p> <p>b. Detection of a <i>new</i> T2 lesion if it appears at any time compared with a reference scan done at least 30 days after the onset of the initial clinical event.</p>

**Appendix 6 Magnetic resonance imaging criteria to demonstrate brain abnormality and demonstration of dissemination in space** (Polman et al., 2005)

Original McDonald Criteria	2005 Revisions
<p>Three of the following:</p> <ol style="list-style-type: none"> <li>1. At least one gadolinium-enhancing lesion or nine T2 hyperintense lesions if there is no gadolinium-enhancing lesion</li> <li>2. At least one infratentorial lesion</li> <li>3. At least one juxtacortical lesion</li> <li>4. At least three periventricular lesions</li> </ol>	<p>Three of the following:</p> <ol style="list-style-type: none"> <li>1. At least one gadolinium-enhancing lesion or nine T2 hyperintense lesions if there is no gadolinium enhancing lesion</li> <li>2. At least one infratentorial lesion</li> <li>3. At least one juxtacortical lesion</li> <li>4. At least three periventricular lesions</li> </ol>
<p>NOTE: One spinal cord lesion can substitute for one brain lesion/</p>	<p>NOTE: A spinal cord lesion can be considered equivalent to a brain infratentorial lesion: an enhancing spinal cord lesion is considered to be equivalent to an enhancing brain lesion, and individual spinal cord lesions can contribute together with individual brain lesions to reach the required number of T2 lesions</p>

**Appendix 7 Diagnosis of multiple sclerosis in disease with progression from onset** (Polman et al., 2005).

Original McDonald Criteria	2005 Revisions
<p>1. Positive CSF <i>and</i></p> <p>2. Dissemination in <i>space</i> by MRI evidence of nine or more T2 brain lesions <i>or</i></p> <p>Two or more cord lesions <i>or</i></p> <p>Four to eight brain lesions and one cord lesion <i>or</i></p> <p>Positive VEP with four to eight MRI lesions <i>or</i></p> <p>Positive VEP with less than four brain lesions plus one cord lesion <i>and</i></p> <p>3. Dissemination in <i>time</i> by MRI <i>or</i> Continued progression for 1 year</p>	<p>1. One year of disease progression (retrospectively or prospectively determined)</p> <p>2. <i>Plus</i> two of the following:</p> <p>a. Positive brain MRI (nine T2 lesions or four or more T2 lesions with positive VEP)</p> <p>b. Positive spinal cord MRI (two focal T2 lesions)</p> <p>c. Positive CSF<sup>a</sup> (isoelectric focusing evidence of oligoclonal IgG bands or increased IgG index, or both).</p>

a MRI demonstration of space dissemination must fulfil the criteria derived from Barkhof and colleagues and Tintoré and co-workers as presented in appendix 5.

CSF = cerebrospinal fluid; MRI = magnetic resonance imaging; VEP = visual-evoked potential.

**Appendix 8 Revised McDonald diagnostic criteria (2010)** (Polman et al., 2011).

Clinical Presentation	Additional Data Needed
<ul style="list-style-type: none"> <li>* 2 or more attacks (relapses)</li> <li>* 2 or more objective clinical lesions</li> </ul>	<p>None; clinical evidence will suffice (additional evidence desirable but must be consistent with MS)</p>
<ul style="list-style-type: none"> <li>* 2 or more attacks</li> <li>* 1 objective clinical lesion</li> </ul>	<p>Dissemination in space, demonstrated by:</p> <ul style="list-style-type: none"> <li>* MRI</li> <li>* or a positive CSF and 2 or more MRI lesions consistent with MS</li> <li>* or further clinical attack involving different site.</li> </ul> <p>New criteria: Dissemination in Space (DIS) can be demonstrated by the presence of 1 or more T2 lesions in at least 2 of 4 of the following areas of the CNS: Periventricular, Juxtacortical, Infratentorial, or Spinal Cord.</p>
<ul style="list-style-type: none"> <li>* 1 attack</li> <li>* 2 or more objective clinical lesions</li> </ul>	<p>Dissemination in time (DIT), demonstrated by:</p> <ul style="list-style-type: none"> <li>* MRI</li> <li>* or second clinical attack</li> </ul> <p>New criteria: No longer a need to have separate MRIs run; Dissemination in time, demonstrated by: Simultaneous presence of asymptomatic gadolinium-enhancing and nonenhancing lesions at any time; or A new T2 and/or gadolinium-enhancing lesion(s) on follow-up MRI, irrespective of its timing with reference to a baseline scan; or Await a second clinical attack. [This allows for quicker diagnosis without sacrificing specificity, while improving sensitivity.]</p>
<ul style="list-style-type: none"> <li>* 1 attack</li> <li>* 1 objective clinical lesion (clinically isolated syndrome)</li> </ul>	<p>New criteria: Dissemination in space and time, demonstrated by:</p> <p>For DIS: 1 or more T2 lesion in at least 2 of 4 MS-typical regions of the CNS (periventricular, juxtacortical, infratentorial, or spinal cord); or Await a second clinical attack implicating a different CNS site; and For DIT: Simultaneous presence of asymptomatic gadolinium-enhancing and nonenhancing lesions at any time; or A new T2 and/or gadolinium-enhancing lesion(s) on follow-up MRI, irrespective of its timing with reference to a baseline scan; or Await a second clinical attack.</p>
<p>Insidious neurological progression suggestive of MS (primary progressive MS)</p>	<p>New criteria: One year of disease progression (retrospectively or prospectively determined) and</p> <p>two or three of the following:</p> <ol style="list-style-type: none"> <li>1. Evidence for DIS in the brain based on 1 or more T2 lesions in the MS-characteristic (periventricular, juxtacortical, or infratentorial) regions</li> <li>2. Evidence for DIS in the spinal cord based on 2 or more T2 lesions in the cord</li> <li>3. Positive CSF (isoelectric focusing evidence of oligoclonal bands and/or elevated IgG index)</li> </ol>

## **Appendix 9 Brodmann areas in the brain of human being**

Areas 3, 1 & 2 - Primary Somatosensory Cortex

Area 4 - Primary Motor Cortex

Area 5 - Somatosensory Association Cortex

Area 6 - Premotor cortex and Supplementary Motor Cortex

Area 7 - Somatosensory Association Cortex

Area 8 - Includes Frontal eye fields

Area 9 - Dorsolateral prefrontal cortex

Area 10 - Anterior prefrontal cortex (most rostral part of superior and middle frontal gyri)

Area 11 - Orbitofrontal area (orbital and rectus gyri, plus part of the rostral part of the superior frontal gyrus)

Area 12 - Orbitofrontal area (used to be part of BA11, refers to the area between the superior frontal gyrus and the inferior rostral sulcus)

Area 13 and Area 14 - Insular cortex

Area 15 - Anterior Temporal Lobe

Area 17 - Primary visual cortex (V1)

Area 18 - Secondary visual cortex (V2)

Area 19 - Associative visual cortex (V3, V4, V5)

Area 20 - Inferior temporal gyrus

Area 21 - Middle temporal gyrus

Area 22 - Superior temporal gyrus, of which the caudal part is usually considered to contain the Wernicke's area

Area 23 - Ventral Posterior cingulate cortex

Area 24 - Ventral Anterior cingulate cortex.

Area 25 - Subgenual cortex (part of the Ventromedial prefrontal cortex)

Area 26 - Ectosplenial portion of the retrosplenial region of the cerebral cortex

Area 27 - Piriform cortex

Area 28 - Posterior Entorhinal Cortex

Area 29 - Retrosplenial cingulate cortex

Area 30 - Part of cingulate cortex



Area 31 - Dorsal Posterior cingulate cortex

Area 32 - Dorsal anterior cingulate cortex

Area 33 - Part of anterior cingulate cortex

Area 34 - Anterior Entorhinal Cortex (on the Parahippocampal gyrus)

Area 35 - Perirhinal cortex (on the Parahippocampal gyrus)

Area 36 - Parahippocampal cortex (on the Parahippocampal gyrus)

Area 37 - Fusiform gyrus

Area 38 - Temporopolar area (most rostral part of the superior and middle temporal gyri)

Area 39 - Angular gyrus, considered by some to be part of Wernicke's area

Area 40 - Supramarginal gyrus considered by some to be part of Wernicke's area

Areas 41 & 42 - Primary and Auditory Association Cortex

Area 43 - Primary gustatory cortex

Area 44 - pars opercularis, part of Broca's area

Area 45 - pars triangularis Broca's area

Area 46 - Dorsolateral prefrontal cortex

Area 47 - Inferior prefrontal gyrus

Area 48 - Retrosubicular area (a small part of the medial surface of the temporal lobe)

Area 49 - Parasubiculum area in a rodent

Area 52 - Parainsular area (at the junction of the temporal lobe and the insula).

**Appendix 10 Protocol of a phase II randomised, assessor-blind, non-treatment controlled, parallel group design exploratory trial to explore the neuroprotective potential of modafinil in multiple sclerosis.**

**STUDY/ TRIAL SYNOPSIS**

Title	Exploring the Neuroprotective Effects of Modafinil in MS
Acronym	MS-MODENA
Short title	MS-Modafinil Effectiveness as Neuroprotective Agent
Chief Investigator	Prof Cris S Constantinescu
Objectives	To test the effects of modafinil on clinical and radiological measures of disease progression and on locus coeruleus activation in patients with progressive multiple sclerosis
Trial Configuration	Randomised, parallel group, assessor blind
Setting	Tertiary care University Hospital
Sample size estimate	A reduction in atrophy rate by 50% will require an approximate sample size of 60 SPMS and PPMS patients (Di Stefano et al Neurology 2010)
Number of participants	60
Eligibility criteria	Clinically definite multiple sclerosis; primary or secondary progressive form. Male or female subjects; 18-70 years of age inclusive; EDSS 4.0-6.5. Females who are of childbearing potential only if taking effective contraception measures
Description of interventions	Modafinil 200 mg daily orally for 24 months
Duration of study	Overall 36 months; 24 months per participant
Randomisation and blinding	Subjects will be randomized to receive either active drug (modafinil) or no treatment at a ratio of 2:1. Pharmacy will be aware of the treatments of the subjects. Randomization will be performed by statistician using an internet program
Outcome measures	Normalised brain atrophy rates; Percent of patients with sustained (two consecutive measurements 6 months apart) disability progression of $\geq 1$ step for EDSS $<5.5$ or $\geq 0.5$ for EDSS $\geq 5.5$ ; Proton MRS measurement of NAA; Change in MSIS29 score; MuSIQoL, MSFC, Rivermead mobility index;  Change in FSS, ESS, NFI-MS; Change in Eye Blink Rate.
Statistical methods	Paired t-test of Mann Whitney test depending on data distribution