

Bresnen, Michael J. (1986) A study of forms of project organisation and matrix management: case studies from the construction industry. PhD thesis, University of Nottingham.

Access from the University of Nottingham repository:

<http://eprints.nottingham.ac.uk/12144/1/373608.pdf>

Copyright and reuse:

The Nottingham ePrints service makes this work by researchers of the University of Nottingham available open access under the following conditions.

- Copyright and all moral rights to the version of the paper presented here belong to the individual author(s) and/or other copyright owners.
- To the extent reasonable and practicable the material made available in Nottingham ePrints has been checked for eligibility before being made available.
- Copies of full items can be used for personal research or study, educational, or not-for-profit purposes without prior permission or charge provided that the authors, title and full bibliographic details are credited, a hyperlink and/or URL is given for the original metadata page and the content is not changed in any way.
- Quotations or similar reproductions must be sufficiently acknowledged.

Please see our full end user licence at:

http://eprints.nottingham.ac.uk/end_user_agreement.pdf

A note on versions:

The version presented here may differ from the published version or from the version of record. If you wish to cite this item you are advised to consult the publisher's version. Please see the repository url above for details on accessing the published version and note that access may require a subscription.

For more information, please contact eprints@nottingham.ac.uk

'A STUDY OF FORMS OF
PROJECT ORGANISATION AND MATRIX MANAGEMENT:
CASE STUDIES FROM THE CONSTRUCTION INDUSTRY'

M. J. Bresnen, B.A.



Thesis submitted to the University of Nottingham
for the degree of Doctor of Philosophy, May, 1986.

© by M. J. Bresnen, May 1986.

**CONTAINS
PULLOUTS**

TABLE OF CONTENTS

INTRODUCTION:

1	Background to the Research	i
2	The Construction Industry	vi
3	Thesis Outline	vii
	Footnotes	x

CHAPTER ONE:

PROJECT AND MATRIX FORMS OF ORGANISATION

1	Dual Structures	1.1
2	Contingency Models of Matrix Organisation	1.5
	2.1 'Organic' Patterns of Management	1.7
	2.2 Differentiation and Integration	1.10
	2.3 Task Uncertainty/ Interdependence and Dual Forms	1.13
3	Models of Matrix Management	1.23
4	Themes from the Literature upon Matrix and Project Management	1.30
	4.1 Team Relationships	1.30
	4.2 Integrators	1.34
	4.3 'Leadership in Matrix Management Settings	1.38
	4.4 Dual Authority and Control	1.49
	4.5 Antecedent Conditions	1.51
	Footnotes	1.54

CHAPTER TWO:

MATRIX MANAGEMENT RESEARCH AND THEORY: SOME EMPIRICAL AND CONCEPTUAL QUESTIONS

1	Research into Matrix and Project Organisations	2.1
---	--	-----

2	Technology, Size and Structure	2.10
	2.1 Technology and Structure	2.10
	2.2 Production Tasks and the Wider Organisation	2.13
	2.3 Group and Organisational Size	2.17
3	The Inter organisational Dimension	2.23
4	External Relationships and the Boundary Unit	2.28
5	External Relationships in a Project Management Setting	2.37
	5.1 Introduction	2.37
	5.2 Interorganisational Relationships	2.38
	5.3 Goals and Power in External Matrix Systems	2.44
	5.4 Implications	2.50
	5.5 Summary	2.54
	Footnotes	2.56

CHAPTER THREE:

MATRIX MANAGEMENT AND THE CONSTRUCTION PROCESS

1	Construction Task Characteristics	3.2
2	The Organisation and Management of Construction Work	3.8
3	Project Organisation Forms	3.11
4	Task Uncertainty and Interdependence	3.18
5	Interorganisational Matrices	3.26
6	Interdependence between Design and Construction Processes	3.32
7	Alternative Delivery Systems	3.35
8	Summary	3.40
	Footnotes	3.42

CHAPTER FOUR:

INTERORGANISATIONAL PROJECT MANAGEMENT IN CONSTRUCTION

1	The Contractual Relationship: The Formal Basis for Interaction	4.2
2	Contractual Terms and Conditions	4.10
3	The Management of the Contract	4.21
4	Triadic Systems of Interaction	4.28
5	Intraorganisational Correlates of Joint Interaction	4.35
	Footnotes	4.47

CHAPTER FIVE:

A STUDY OF CONSTRUCTION ORGANISATION AND MANAGEMENT

1	A Model of the Structure and Processes of Interaction in Project Management	5.3
	1.1 Task and Organisational Attributes	5.7
	1.2 The Impact of the Formal Agreement	5.10
	1.3 Influencing Outcomes in Interaction	5.17
2	Research Strategy	5.26
	2.1 External Validity	5.30
	2.2 Construct Validity, Internal Validity and Reliability	5.32
3	The Sample of Cases	5.36
	3.1 The Unit of Analysis	5.36
	3.2 The Case Studies: Selection and Access	5.39
	3.3 Fieldwork	5.43
4	Methodology	5.47
	4.1 The Programme of Visits	5.47
	4.2 The Participants	5.48
	4.3 The Methods Employed	5.50

5	The Collation, Presentation and Analysis of the Data	5.55
	5.1 Collation	5.55
	5.2 The Presentation of the Cases	5.56
	5.3 The Intercase Analysis	5.61
	5.4 An Illustration of the Methods Employed	5.63
	Footnotes	5.70

CHAPTER SIX:

CASE STUDY: THE RIVERSIDE ADVANCE WORKS PROJECT (RAW)

1	The Project, Client and Context	6.1
2	The Client's Representatives	6.3
3	The Main Contractor	6.5
4	The Design Process and Design Organisation	6.7
5	Characteristics of the Design	6.8
6	Tendering and the Main Contract	6.11
7	The Main Contractor's Site Team	6.13
8	The Client's Supervision	6.17
9	The Organisation and Management of Construction	6.19
10	Performance on the RAW Project	6.31
11	The RAW Project: A Case Analysis	6.34

CHAPTER SEVEN:

CASE STUDY: THE ADVANCE FACTORY UNITS PROJECT (AFU)

1	The Project, Client and Context	7.1
2	The Client's Representatives	7.2

3	The Main Contractor	7.3
4	The Design Process and Design Organisation	7.5
5	Characteristics of the Design	7.7
6	Tendering and the Main Contract	7.9
7	The Main Contractor's Site Team	7.12
8	The Client's Supervision	7.15
9	The Organisation and Management of Work on Site	7.18
10	Performance on the AFU Project	7.28
11	The AFU Project: A Case Analysis	7.30

CHAPTER EIGHT:

CASE STUDY: THE MATERIALS TESTING STATION (MTS)

1	The Project, Client and Context	8.1
2	The Client's Representatives	8.2
3	The Main Contractor	8.6
4	The Design Process and Design Organisation	8.7
5	Characteristics of the Design	8.10
6	Tendering and the Main Contract	8.12
7	The Main Contractor's Site Team	8.14
8	The Client's Supervision	8.17
9	Performance on the MTS Project	8.22
10	The MTS Project: A Case Analysis	8.25

CHAPTER NINE:

CASE STUDY: THE NEW SCIENCE SCHOOL (NSS)

1	The Project, Client and Context	9.1
2	The Client's Representatives	9.2
3	The Main Contractor	9.4
4	The Design Process and Design Organisation	9.5
5	Characteristics of the Design	9.8
6	Tendering and the Main Contract	9.10
7	The Main Contractor's Site Team	9.13
8	The Client's Supervision	9.16
9	Performance on the NSS Project	9.20
10	The NSS Project: A Case Analysis	9.25

CHAPTER TEN:

CASE STUDY: THE PRODUCT DEVELOPMENT LABORATORY (PDL)

1	The Project, Client and Context	10.1
2	The Client's Representatives	10.2
3	The Main Contractor	10.4
4	The Design Process and Design Organisation	10.7
5	Characteristics of the Design	10.8
6	Tendering and the Main Contract	10.11
7	The Main Contractor's Site Team	10.15
8	The Client's Supervision	10.20
9	The Organisation and Management of Work on Site	10.23

10	Performance on the PDL Project	10.34
11	The PDL Project: A Case Analysis	10.41

CHAPTER ELEVEN:

INTERCASE COMPARISONS AND CONTRASTS

1	The Projects and their Context	11.2
2	The Participating Organisations	11.7
3	The Pre-site Design and Planning Process	11.24
4	The Design Organisation	11.31
5	The Main Contractor's Organisation	11.39
	Footnotes	11.45

CHAPTER TWELVE:

AN INTERCASE ANALYSIS

1	The Organisation and Management of Work on Site	12.1
2	Roles and Relationships within the Interorganisational Matrix	12.12
3	A Review of Case Histories	12.31

CHAPTER THIRTEEN:

DISCUSSION

1	Summary of the Main Findings	13.1
2	Discussion	13.9

2.1	The 'Organic' Task Team Group	13.10
2.2	Integrative Mechanisms	13.15
2.3	'Cultural' Compatibility	13.23
2.4	'Leadership' in Project Systems	13.28
3	Areas for Future Research	13.35
4	Summary	13.38

CHAPTER FOURTEEN:

CONCLUSION

APPENDICES:

- A Questionnaire
- B Interview Schedule
- C Bibliography

ABSTRACT

This study investigates the forms and processes of interaction that occur in the organisation and management of projects. It takes as its empirical focus of enquiry the situation in the UK construction industry; and uses, as its database, five case studies of medium to large-scale, 'one-off' construction projects.

The literature on project organisation and management is reviewed, with attention directed towards the phenomenon of matrix forms of organisation and related processes of management. A critique is developed which assesses the implications of inter-organisational linkages in the coordination and control of project task work. This critique forms the basis for a model of construction organisation and management from which a series of propositions are derived for empirical investigation.

Five case studies of construction projects, explored longitudinally and using qualitative research techniques, are described and analysed. The main finding to emerge from the study is that: the more there is a need for a more 'flexible' administrative arrangement and approach towards managing work that is complex, uncertain and inter-dependent, the less likely this is in fact to occur, to the extent that 'contractual' considerations inform the parties' approaches. This is contingent upon three sets of features: the form and basis of the relationship, and its meaning to those involved; the broader relationship between the organisations concerned (eg their goals, resources); and the internal setting within each organisational group.

The implications of the findings for models of project and matrix organisation are assessed. A recommendation is made for the more explicit and separate treatment of interorganisational relationships, due to the differential motivational basis underlying interaction.

ACKNOWLEDGEMENTS:

I would like to thank my supervisor, Don Varley, for his considerable help, support and encouragement in formulating, developing and conducting this research project, and for his continued interest in, and enthusiasm for, the project over its course. Many thanks too to John Johnson of the Dept. of Industrial Economics, and Graham Cullingsford and Mick Mawdesley from the Dept. of Civil Engineering for their early help and encouragement.

Without the cooperation and assistance of those who agreed to participate in each of the cases, this study would not have been possible. I would, therefore, particularly like to thank those who were involved, for their willingness to cooperate, their continued interest and - perhaps most of all - their patience ! Thanks are also due to staff at the Building Research Station, Garston, and to the many people within the industry who expressed their interest in the study by taking time off from busy schedules to discuss the project with me.

Special thanks are due to Angela Murphy who typed the manuscript, and who put in a considerable amount of hard work in preparing it in time for this submission.

Last, but by no means least, I would like to thank Becky, Tina, Chris and Dave for their constant support and encouragement, particularly over the course of the last eighteen months; Sue Fuller for her example and support; and current and past members of the Work and Employment Research Group at Loughborough for their help and encouragement.

Mike Bresnen 1.5.86.

INTRODUCTION

This study aims to investigate the forms and processes of interaction that occur in the organisation and management of projects. In doing so, it specifically focuses upon the organisation and management of construction projects, and takes five illustrative case studies of medium to large scale, one-off construction projects as its database.

1 Background to the Research

In recent years, a good deal of attention has been directed, by organisational and management theorists and researchers, towards the operating characteristics of various types of project-based forms of organisation. This attention has stemmed from a long-standing and broader interest in studying the effects of environmental constraints and contingencies upon the internal structure and functioning of organisations. The contingency framework that has been adopted over the last twenty years or so for investigating features of the growth, functioning and development of organisational forms in general, has also formed the central plank in attempts to chart features of the functioning and development of project organisations. These are characterised by the fact that their mainstream activities are project-centred, and that such activities are commonly undertaken in increasingly "turbulent" (Emery and Trist 1965) market and technological task environment conditions.

This line of enquiry has taken as its starting point the

particular idiosyncratic features of project taskwork: specifically, the fact that project tasks involve frequently large, one-off products, custom-built to specifications supplied by an external (client) body; and that the pattern of activity in the performance of project taskwork is essentially 'cyclical' in nature. These defining characteristics distinguish project-based forms of activity, from the types of production activity found in more recurrent and stable settings, and suggest a point of departure from the investigation of organisational and managerial phenomena in more 'traditional' types of setting (eg manufacturing, retailing).

The undertaking of project tasks by organisations is, of course, by no means a recent development. Indeed, the focus of this study is upon one sector of industrial activity - construction - which has historically been project-oriented in its organisation and management of work. What explains the more recent interest in organisational developments with respect to projects, is the increasingly common tendency for project taskwork to be performed in conditions characterised by high rates of technological change. The investigation of project 'systems' of organisation dovetails with, and to a large extent derives from, a more general interest, in the field of organisational theory and research, in characteristics of forms of organisation operating in technologically complex and uncertain task environments (eg Burns and Stalker 1961). Project organisations operating in this type of environment are encompassed within the broad cluster of types of organisations labelled by Mintzberg (1979) as "adhocracies". More specifically, such project organisations have been identified as those in which some form and

degree of "matrix" organisation and management is the norm (eg Knight 1977; Galbraith 1971, 1973, 1977; Kingdon 1973). The contingency framework essentially specifies that there is 'no one best way to organise', and that the effective organisation of work is contingent upon the requirements posed by the nature of the task being undertaken. In mainstream organisational theory and research such a framework has led to examining the impact of, among other things, levels of task uncertainty, upon the internal structure and functioning of organisations (eg Burns and Stalker 1961, Lawrence and Lorsch 1967). In the theory and research upon project-based forms of organisation, the impact of such conditions, coupled with the idiosyncratic nature of project-based activity, has formed the basis for the examination of the distinctive characteristics of firms undertaking project work in complex and dynamic task environments. The consequent effects of complexity and change across two significant dimensions of the task being performed (ie its technology and markets), has formed the backdrop for studying the distinct type of organisational complexity found in such settings.

The literature upon complex project organisations, and in particular, upon dual or 'matrix' systems of management in the performance of project taskwork, is extensive. At the same time, however, its empirical underpinnings are somewhat lean, and many of the propositions established from models of matrix management in complex project organisations remain to be tested. Furthermore, the types of situations in which such phenomena have been investigated till now have been mainly highly particular and

idiosyncratic. Despite a plethora of interest, and a catalogue of recommendations, the growing body of theory in this area has seldom been taken as the basis for more extensive and systematic exploration of the range of propositions that are derived. Moreover, the history of research into such phenomena has itself been of a somewhat idiosyncratic and specific nature. Firstly, the models proposed have emerged from highly specific examples in practice of complex project 'systems' (such as the NASA Apollo project of the 1960's (eg Kingdon 1973)). Secondly, research has tended to focus almost in its entirety upon high technology endeavours in large-scale project undertakings. Thirdly, the frame of reference employed in the research has commonly been 'action-centred' (eg Argyris 1972), and the propositions established highly normative in character, reflecting the aim of influencing the strategic choice of design options faced by organisations concerned (cf Child 1972). Important findings and themes have emerged from this area of research. However, these factors have combined to militate against the comparative examination of such tendencies: both between such types of organisation and those found in other forms of industrial activity; and, more importantly for this study, between such types of project-based forms of organisation and others operating in perhaps qualitatively or quantitatively distinct types of project environment. The highly contingent basis for research in such settings is recognised and acknowledged. However, the very focused field of research into such areas has made difficult the comparative examination of broad similarities and differences across different types of project-based activity.

The intention in this study is to explore characteristics of the forms and processes of interaction found in the organisation and management of projects, focusing specifically upon the case of construction projects. The aim will be to assess the applicability of the theoretical constructs of matrix and project management in a setting which receives comparatively little attention in this respect, but which is often singled out as a type of setting in which the existence of a complex and dynamic task environment is the norm (eg Higgin and Jessop 1965, Crichton 1966). Indeed, for a sector of industrial activity that occupies such a prominent position within this and other economies,¹ and which is marked by its distinctive and interesting organisational characteristics, there has been a comparative paucity of research undertaken in it by social scientists interested generally in the structure and functioning of complex organisations. Its distinctive characteristics have perhaps rather separated it out as a 'special case', rather than as a sector of activity that yields potentially fruitful comparisons and contrasts with other types of industrial setting (eg manufacturing). A sizeable body of literature exists based upon theory and research undertaken by those specifically interested in construction management phenomena. However, generally speaking, although the overlap between these three broad areas has been extensive, rarely have those areas of interest sufficiently dovetailed in such a way that would allow a potentially important cross-fertilisation of ideas.

The construction industry is a large and highly diverse sector of industrial activity. It ranges from the construction of multi-million pound power plants, through the construction of large residential and non-residential buildings, to the small scale renovation or repair of existing facilities. It encompasses different types of work: from the construction of buildings for residential and non-residential use; to the laying of roads and other infrastructure facilities; to the installation in buildings of services (heating, lighting, ventilation, plumbing, etc). It also ranges in type from new construction to the repair and maintenance of existing facilities.² Public sector expenditure accounts for a significant proportion (some 60%) of total expenditure on new and remedial works,³ indicating further the importance of public sector clients to the industry as a whole.

It is not the intention in this thesis to address characteristics of the industry at a more aggregated sectoral level, since the focus of this study is much more 'microscopic' - focusing upon patterns of interaction in the management of specific construction projects.⁴ However, one important characteristic of the nature of the industry must needs be mentioned here since it has an important bearing upon the main thrust of this thesis. Specifically it is that the organisation and management of construction projects involves, to varying degrees, inter-linkages between a variety of different types of organisation involved to varying degrees and in varying ways throughout the total project 'cycle'. In particular the

industry is characterised by an historical split between those organisations involved in, respectively, the design and construction of project work.⁵ In addition, the industry is one in which the phenomenon of subcontracting sections of the work is a widespread mode of operation.⁶ For the purposes of this study, the important point to bear in mind here is that the choice of the project as the unit of analysis for investigation, makes central the need to focus upon interorganisational relationships in the management of project work. A more detailed discussion of the circumstances in construction in this respect is returned to in Chapter 3 below.

3 Thesis Outline

The plan for the remainder of this thesis is as follows. In Chapter 1, theories and findings from investigations of organisational and managerial patterns and processes in complex project organisational settings are presented and discussed, with a view to identifying broad themes, and comparisons and contrasts in the literature. In Chapter 2, a critique of this literature is developed. Specific attention is directed here towards the empirical findings obtained and the characteristics of the research strategies employed in investigating such phenomena. Following this, attention is directed towards the potential impact of two sets of contingency factors that receive comparatively little direct and systematic attention in the literature: namely, organisational size and inter-organisational dependencies and relationships. The argument developed in the latter respect forms the central crux of this thesis. It is that students of matrix, project-based forms of organisation

rarely systematically explore the potential impact of external relationships in the management of project work. In not doing so, a potentially significant source of explanation for variation in the patterns and processes of interaction observed internally is possibly lost. Furthermore, that external relationships mark a point of departure in the investigation of interorganisational as opposed to organisational, processes of management in a project setting.

In Chapter 3, the issues raised and discussed in the first two chapters are related more specifically to the characteristics of work and organisation found in a construction project setting. Following this, in Chapter 4, the issues raised in Chapters 1 and 2, and related to the construction project situation in Chapter 3, are developed into a discussion of the potential impact of various sets of factors upon the forms and processes of managerial action that may be expected to occur in the setting discussed here. In the first part of Chapter 5, this discussion is crystallised into a model of forms and processes of interaction in a construction project management setting, from which a series of propositions are derived and presented.

The second part of Chapter 5 outlines in some detail the research strategy pursued in this study. The strategy employed and the details of the methodology are given, together with broad descriptions of the case studies investigated here, sampling, access and fieldwork. Particular stress is laid upon these issues due to the essentially exploratory nature of the research and its

manifestation in a longitudinal, case study approach, heavily reliant upon the use of qualitative techniques for data collection and analysis.

In Chapters 6 to 10, each of the case studies undertaken is described in detail. Chapter 11 broadly compares and contrasts the cases according to the dimensions of interest to the study, while Chapter 12 turns more fully to an analysis of the data with respect to observed patterns and processes of organisation and management in the context of the situations as depicted and compared in Chapter 11. In Chapter 13, a discussion of the findings in relation to the earlier theoretical statements is undertaken. The thesis concludes with a brief summary and conclusion of the research and its implications in Chapter 14.

Footnotes

- 1 Estimates suggest the industry continues to account for 6% - 7% of annual GDP, and employs in the region of 9% - 10% of the total workforce (Source: "House's Guide to the Construction Industry" 7th ed, 1979-80), Whitefriars Press; London, 1981).
- 2 For a fuller definition, see Order XX of the Standard Industrial Classification, HMSO, 1981. Repair and maintenance of existing facilities accounts for some 40% in total output within the industry (Source: Monthly Digest of Statistics, HMSO, August 1982).
- 3 Source: Monthly Digest of Statistics, HMSO, August 1982.
- 4 The interested reader is referred to Fleming (1980), for example, for a discussion of characteristics of the industry in terms of levels of industrial concentration, employment patterns, etc. Also to House's Guide to the Construction Industry (op cit, Ch 12).
- 5 Such a split is manifested in the fact that organisations undertaking 'design' activities (eg architectural partnerships) are defined under a separate section of the SIC (namely, Div 8, Group 837, Class 8370), despite the complementarity of the functions performed in the total project undertaking. For a description of the position of these professional groups within the industry, and their role in the total design-construction project process, see, for instance, House's Guide to the Construction Industry (op cit, Ch 13).
- 6 See, for instance, Bresnen et al (1985). An additional and related phenomenon is the extensiveness of the number of small firms within the industry. In 1980, for instance, 80% of the registered firms in the industry employed fewer than seven people, and only .125% employed over 600 (Source: Private Contractors' Construction Census, 1972-80 Dept of the Environment, HMSO, London 1981). For the reasons for the continued importance of the small scale sector, see for instance, Fleming (1980).

PROJECT AND MATRIX FORMS OF ORGANISATION

1.1 Dual Structures

Recent studies of the organisational forms established for the management of project work have taken as their starting point the premise that firms face dual pressures stemming from the characteristics of their task environments. On the one hand, there is a need to structure the organisation in such a way as to allow for the orientation of activities towards the achievement of specific, but non-recurring, project objectives. Typically, the type of work involved consists of the construction (and/or design) of series of medium to large scale, one-off, custom-built products - each for a distinct client, and each to be built over a relatively short period of time. These sources of variation in the type of products being built make it important for the organisation to have the capacity to be able to respond to diversity and change in product market conditions, and to achieve a level of interdepartmental co-ordination consistent with the achievement of short-term project objectives. On the other hand, there is a need for the firm to establish a structure and modus operandi that allows for the maintenance and development of its distinct functional specialisms. This both to achieve the benefits - through economies of scale - of specialisation (Galbraith 1973, 1977), and to help ensure the survival of the firm in the long run. Typically, the latter point relates to firms operating in conditions of rapid technological change (eg Kingdon 1973, Sayles and Chandler 1971). An orientation towards specific projects and clients which is consistent with short-term commercial success, is balanced with the need for the firm to develop its specialist technical support capacity in a variety of specialisms in order to maintain or improve its competitive position in the long-run. The NASA Apollo programme of the 1960's, which has been the subject of a good

deal of organisational research,¹ has served as one prominent example of the explicit adoption of a complex organisational form to accommodate this dual orientation. Kingdon (1973), for instance, described the establishment of a matrix organisation in this context as a pragmatic response to the need to fulfill two sets of requirements: the client's need for unified direction of the project to avoid them having to negotiate with a number of functional managers; and the contracted company's need to maintain its capacity for handling current and future projects in a fast-changing, high technology environment through the maintenance of strong specialist departments. // Other descriptions of the same instance (eg Sayles and Chandler 1971) have drawn a similar broad distinction between project and functional orientations in this type of environment. And the need to strike a balance between close interorganisational collaboration and organisational autonomy and independence has formed the backdrop to much of the discussion of matrix organisation in this particular setting.

More broadly-based models have similarly focused attention upon the existence of diversity and change across two dimensions associated with the tasks being performed by the organisation. Most commonly, these are taken to be product market and technological conditions respectively (Galbraith 1971, 1973, 1977, Knight 1977, Sayles 1976). However, other dimensions have also been included: notably that related to the geographical dispersion of a firm's activities (cf Davis 1974). The general point is that the traditional conception of the design of the organisation being based at any one level upon a single criterion, is extended to the prospect of it being based at any one level upon dual criteria, given the particular constellation of task environment conditions facing the organisation. Thus, for

instance, the choice between technology, territory or time (Miller. 1959) - or product, process or place (Gulick and Urwick 1937) - as the basis of organisation,² is elaborated by the potential suitability of organising simultaneously across two dimensions (eg product and place). More broadly, some authors, following Williamson's (1975) and Chandler's (1962) historical perspectives have taken matrix organisation as representing a development and novel alternative to the traditional U- and M-forms of organisation (Davis 1974, Drucker 1974).³

While the bulk of attention has tended to be directed towards matrix-type structures of organisation operating in high technology settings, this should not obscure the centrality of a dual orientation stemming from diversity and change across two dimensions as the defining characteristic of the conditions under which a matrix system is likely to emerge or be introduced. It is not high technology per se that constitutes the rationale for matrix organisation. // Rather it is the need to respond to two sets of complex and dynamic environmental conditions (one of which may be technological change) that forms the basis for a matrix system of management. // Indeed the central theme of this study is the relevance of issues connected with the operation of matrix structures in an environment (ie construction) within which there is a need to achieve a dual orientation, but at the same time in perhaps less complex and dynamic settings - certainly with regard to the type of production technology employed.

Most of the interest in matrix management in project systems has focused upon three main sets of issues: identifying the factors

that make a matrix a suitable form of organisation; identifying and categorising the forms and types of matrix system found in practice; and identifying (and seeking solutions to) the types of problems found in implementing and operating the form and which stem from, or are related to, its peculiar characteristics. Before looking in more detail at the third set of issues which form the basis for the propositions to be explored in this study in the construction setting, a review of the literature with respect to the rationale for and manifestations of matrix organisation will be undertaken. Following this review, in Chapter 2, a critique of the literature will be developed. In Chapter 3, the issues raised will be linked with the task and organisational characteristics of activity related to the design and construction of building projects.

1.2 Contingency Models of Matrix Organisation

As implied in the foregoing discussion, research into complex forms established for the management of project-based work, has been based considerably upon a contingency framework for the study of the development and operation of organisational structures.⁴ The focus has been upon the tasks undertaken by the organisation and their resultant manifestation in a variety of models of organisation in which patterns of dual management are the norm. One of the earliest statements of the rationale for establishing a dual structure and its manifestation in a matrix form concentrated upon the type of task undertaken, focusing specifically upon the form of product produced and the associated production system employed:

"It is when work performance is for specific project contracts that a matrix organisation can be used effectively. If the market for a product is a single customer ... the production emphasis changes to the completion of action for a specific work project instead of a flow of work on production programmes for product volume."

(Mee 1964, p71)

The emphasis upon unit, as opposed to large batch and process production (Woodward 1958, 1965) as a defining characteristic, continues in subsequent studies of the form, although the emphasis shifts towards general characteristics of the task being performed rather than focusing only upon the characteristic type of production system employed. In other words, unit production systems tend to be more closely associated with matrix organisation; but not all unit production systems exhibit features of a matrix organisation. The central concepts that have been used to explore the emergence of complex organisational forms such as the matrix have been the concepts of task uncertainty, complexity and interdependence. An emphasis has

been placed upon examining the effects of these variables upon the managerial processes of planning, co-ordinating and controlling taskwork, and their implications for workunit structure and processes of problem-solving, communication and decision-making in a situation in which the close collaboration of specialists from a variety of separate groups or departments within the organisation is required.

The conceptual underpinnings of the approach stem back to the early conception of firms operating in increasingly "turbulent" environments (Emery and Trist 1965, 1969) and, in particular, to Thompson's (1967) analysis of organisations seeking to manage their dependency upon the environment by adopting strategies aimed at achieving a level of "closed-system logic" at the technical level (Parsons 1960). The former approach finds perhaps its strongest advocate in Kingdon's (1973) systems approach to the design of complex organisational forms. Galbraith's "information-processing model" (1973, 1977), based similarly upon a systems approach, also relates the proliferation of complex structural forms to the nature of the organisation's environment via the nature of the tasks performed. It provides perhaps the most comprehensive statement of the organisational design options available given particular sets of task environment conditions that place a premium upon organising to achieve a dual orientation.⁵ These authors share in common with Knight (1977) and others (eg Sayles 1976) the presumption that dual structures of management may at one level provide the means whereby the organisation can achieve both internal efficiency in the use of its resources and also the capability of dealing with the pressures associated with responding to individual projects' requirements and pressures. At another, and more operational level, that they allow

for the achievement of a sufficient level of co-ordination of activities and integration between subgroups (Lawrence and Lorsch 1967) in conditions of high levels of task complexity and uncertainty and where levels of reciprocal interdependence (Thompson 1967, p54) between subtasks is high. Indeed, it is generally held that matrix management (in one form or another) offers a solution in certain circumstances to the problems faced by the organisation in achieving appropriate levels of "differentiation" and "integration" (Lawrence and Lorsch 1967) in increasingly "turbulent" environments (Galbraith op cit). Sayles (1976) suggests further that variants of the form are in fact quite common in practice, and associated with the resolution of these divergent tendencies in certain types of industrial settings.

1.2.1 'Organic' Patterns of Management

The analysis of matrix and related systems of management is underpinned by two important sets of findings in organisational theory that have lent considerable weight to the contingency perspective. The first was the early study by Burns and Stalker (1966). In their study of 20 English and Scottish firms in the electronics industry, they discovered that a relationship existed between the degree of uncertainty facing the firms - arising due to a high rate of technological change manifested in a high rate of change of product lines - and the efficacy of the form of organisation in operation in terms of the rate of innovation. From their findings, they derived a continuum stretching between two 'pure' models of organisation: the 'mechanistic' and 'organic' types. The former was characterised by features of the classic bureaucracy described by Weber (1947). These included the specialisation of roles according to detailed subdivisions of the task to be performed; full formal specification of the technical

methods to be employed by functional role-holders and detailed descriptions of their formal rights and obligations; the existence of a hierarchical structure of control, authority and communication in which vertical interaction and 'top-down' decision-making were the norms; and an emphasis upon internal and position-based loyalty and affiliation. In contrast, the 'organic' model was characterised by the 'contributive' basis of knowledge and skills applied to the performance of the task of the concern as a whole; the continual re-definition of individuals' functions and roles through interaction, and a broadening of the scope of role-holders' responsibilities; the existence of "network" systems of control, authority and communication - in which lateral interaction and the exercise of authority based upon expertise and specialist knowledge came to the fore; and a more 'cosmopolitan' outlook, wherein technical and professional loyalty and affiliation were more highly valued than loyalty to the firm or one's own department.⁶ These sets of characteristics yielded a variety of individual dimensions or variables along which firms would be expected to differ: the aggregated cluster of attributes identified in any one situation would determine the relative location of the organisation on the continuum - whether firms tended towards the 'mechanistic' or 'organic' ends of the continuum. They found that the level of company performance achieved was related to the fit between environmental and structural characteristics: 'mechanistic' organisations tended to operate most effectively in task environments that were relatively static, routine and stable; whereas 'organic' firms operated most effectively in uncertain, complex and changing task environments. (It has been the latter set of conditions that have prompted investigations of the matrix phenomenon.) Their other central finding pertained to the difficulties associated with

introducing and operating a form of organisation run on 'organic' lines. They found that the ability of firms to respond to more demanding conditions was constrained by the tendency for sectional, political and individual career interests to play an important part in the workings of the firm:

"Neither political nor career preoccupations operate covertly, or even, in some cases, consciously. They give rise to intricate manoeuvres and counter-moves, all of them expressed through decisions, or in discussions about decisions, concerning the organisation and the policies of the firm. Since sectional interests and preoccupations with advancement only display themselves in terms of the working organisation, that organisation becomes more or less adjusted to serving the ends of the political and career system rather than those of the concern ... These divert organisations from purposive adaptation."

(Burns 1963, p20)

Their observation was that such factors led to the perpetuation of outdated systems and to 'pathologies' in structure: rather than the organisation adapting by becoming more 'organic' in response to exogenous pressures, the tendency might well be for an essentially 'mechanistic' organisation to be retained, with 'elaborations' to cope with external pressures being made and based upon "political and career system" criteria.

With respect to the central finding of the association between task uncertainty and the requisite organisational form, other studies have since found similar tendencies towards a more 'organic' form of workunit structure in conditions of task uncertainty (eg Duncan 1972, Van de Ven et al 1974, 1976). Taken as a whole, the results confirm the expectations that greater task complexity and uncertainty require a correspondingly greater input of specialist expertise and information for problem-solving and decision-making processes

(Perrow 1967); that (perceived) task complexity (Van de Ven et al 1974) and, especially, task uncertainty - reflected in how often factors considered are subject to change, and how often new and different factors need to be taken into account (Duncan 1972) - affect decisional processes and in a manner consistent with that described in the 'organic' system; and that high levels of task uncertainty and complexity, coupled with greater subtask interdependence, are reflected in the tendency towards more flexible and participative structures of interaction (Van de Ven et al 1974, Hall 1968). Van de Ven et al (1974) for instance, found that where tasks are medium to high in perceived "difficulty" and high in perceived "variability" (or uncertainty) then "group modes" become appropriate for problem-solving and decision-making processes.

1.2.2 Differentiation and Integration

The second major study investigated the effects of differential levels of task uncertainty upon subunits of the organisation. The investigation was by Lawrence and Lorsch (1967) who conducted a comparative study of ten business firms operating in three separate industries: containers, food and plastics. These were taken as representative of three distinct types of environment, characterised by differences in the degrees of 'scientific', 'techno-economic' and 'market' uncertainty faced by each firm's research, production and sales departments respectively. 'Uncertainty' was scored according to the lack of clarity of information available, the uncertainty of causal relations in taskwork processes (Thompson's (1967) "cause-effect beliefs"), and the time span of definitive performance feedback. From their results, Lawrence and Lorsch sought to establish the appropriate states of "differentiation" and "integration" required for effective task performance under widely varying conditions, and to analyse how

these states were effectively achieved. They defined "differentiation" as:

"... differences in the cognitive and emotional orientation among managers in different functional departments."

(ibid, p47)

This meant not simply segmentation and specialisation of knowledge as a consequence of the degree of functional and role specialisation within the firm, but also attendant differences that arose in attitudes and behaviour. In particular they noted differences in orientation towards time, goals and interpersonal relations as well as variation in the formality of structure between departments. Divergent goal orientations have commonly been identified in studies of inter-departmental working relationships within organisations (eg Blau and Scott 1964). Similarly differences in behavioural norms or, more generally, 'ways of working and thinking'. The impact of differential conditions upon the structural attributes of different departments within the same organisation has also received a good deal of attention (cf Hall 1968, 1977, Hage and Aiken 1969). Hall (1968) for instance, found that the degree of task diversity and predictability facing production and R & D departments respectively in a number of organisations corresponded closely to their structural attributes: the former were generally more 'mechanistic' in form, the latter more 'organic'. Research into R & D departments has consistently pointed to distinctive 'organic' tendencies in the form and processes of interaction observed (eg Allen and Cohen 1969, Bergen 1975).

Lawrence and Lorsch (1967) then went on to define "integration" as:

"... the quality of the state of collaboration that

exists among departments that are required to achieve unity of effort by the demands of the environment."

(ibid, p47)

They found that, as the nature of the task being undertaken by the organisation increased in uncertainty, there was a need for a greater degree of specialisation to cope with the additional information and specialist knowledge needed to perform the task. At the same time, however, greater levels of subtask interdependence meant that a greater emphasis was also put upon achieving a high level of "integration" consistent with allowing for the greater technical and administrative complexity of the task. The two sets of requirements - to differentiate and integrate - while being complementary needs in conditions of increased task uncertainty, were also somewhat incompatible: the differences in orientation that occurred through differentiation associated with specialisation made integration between departments increasingly difficult to achieve. Relating these factors to the level of company performance across the three types of environment investigated, they found that a close relationship existed between the extent to which firms responded to environmental conditions and their ability to perform effectively within that context. Thus, high performing firms in uncertain environments (eg the plastics industry) managed to achieve high levels of both differentiation and integration. Given the contradictions posed by the two sets of requirements, their ability to perform effectively was conditioned by the establishment of appropriate "conflict-resolution mechanisms" within the structure of the organisation. These served to enable the firms to achieve the high level of integration required amongst highly differentiated groups holding divergent perspectives or orientations. The specific mechanisms they

identified included, in all three industries, those found in a traditional bureaucratic structure (namely the managerial hierarchy, paper systems, and informal patterns of direct contact between departmental managers). However, in the least differentiated setting (the container industry) such mechanisms were effectively all that were needed. In the more uncertain setting of the food industry, where there needed to be greater differentiation, successful firms also made use of temporary cross-functional teams, and perhaps individual integrators whose role was to ensure cross-departmental collaboration. In the highly uncertain and highly differentiated setting of the plastics industry, successful firms tended to go further, with the establishment of a permanent team structure and extensive use of individual integrators, and perhaps the establishment of a separate department geared towards the performance of this role. The mechanisms were consequently cumulative and contingent upon the level of task uncertainty faced and the consequential tendencies towards greater functional differentiation and the greater cross-functional integration required for effective performance.

1.2.3 Task Uncertainty/Interdependence and Dual Forms

Studies of the class of organisation in which some form of dual management is the norm have relied extensively upon the phenomena described in these two studies. Levels of task uncertainty (and/or complexity) coupled with levels of interdependence between subtasks have been taken as the independent variables upon which the design of the organisation for effective performance is contingent. Attention has been directed towards both the more flexible structure and processes of interaction observed in task groups operating within matrix settings (the 'organic' model), and to the impact of differentiation and the structural imperatives this requires to

achieve integration in more complex and unstable settings. Galbraith's (1971, 1973, 1977) model serves as one prominent and important example of this approach. He views the establishment of matrix organisation as the culmination of the organisation's attempts to manage its dependency upon the environment in conditions of increasing levels of task uncertainty. He defines task uncertainty as the difference between the amount of information required to perform a task and the amount of information already available to organisational members (ibid, 1977, p36).

The view expressed by Galbraith and echoed in the works of other systems theorists exploring the field, is that the greater the amount of task uncertainty - this being a function of the diversity of outputs and input resources and the level of goal difficulty - then the greater the amount of information that needs to be processed by decision-makers during the course of taskwork in order to achieve a given level of performance. His thesis is that, as the level of task uncertainty facing the firm increases, so greater pressure is put upon the hierarchical system for managing exceptions during task execution. In this event, it becomes more difficult to solve problems and reach decisions within the confines and constraints of a traditional bureaucratic structure. This he categorises as "information overload" to which the appropriate response is the establishment of additional - but increasingly costly - mechanisms which free upper levels of management from excessive involvement in detailed operational decision-making and which, therefore, move the point of decision down to the level in the organisation at which the relevant information and expertise exists (ibid, 1973, p18).

It should perhaps be noted at this point that the specific focus upon informational requirements in complex and unstable settings is common to other systems models of dual management structures (ie Kingdon 1973, Sayles 1976) as well as that proposed by Galbraith. In focusing upon the organisation's or task group's 'capacity to process information' however, such approaches tend to narrow the scope of the meaning of uncertainty. While it is accepted that more information will undoubtedly be needed for decision-makers under conditions of uncertainty, this does not necessarily mean that lack of information per se is a sufficient measure of uncertainty. Nor does it give sufficient insight into the decisional processes involved. While "unstructured problems" (Simon and Shaw 1964, Vroom and Yetton 1973) requiring "non-programmed decisions" (March and Simon 1958, Simon 1960) may indeed be characterised by many unknowns with regard to alternative solutions, methods and/or parameters, this does not necessarily mean that the process of problem-identification, analysis, solution and implementation is directly related to the information-processing capacity of the workunit as Galbraith and others (eg Duncan 1972) suggest. The underlying assumption tends to be that with sufficient information available, the problems could be solved and decisions reached with recourse to an essentially computational strategy (Thompson 1967). However, in this more technical interpretation of the meaning of uncertainty, several important points tend to be missed (despite them being of recognised critical significance in subsequent analyses of decisional processes within the workunit group in complex structures).

Firstly, lack of prior information and task uncertainty are by no means synonymous: it is quite possible to conceive of situations in

which there is sufficient information to deal with problems that may occur - the key factor is that their occurrence is largely unpredictable; conversely, that predictable potential problems have unknown solutions despite a plethora of information concerning their parameters and consequences. Secondly, and related to the processes involved, there is an implicit tendency to emphasise the quantitative as opposed to qualitative aspects of informational flow, and to downgrade more subjective and judgemental elements related to the notion of expertise and specialised knowledge - such as hunch, intuition and educated guesswork that may be involved in problem-solving exercises (Simon 1960). On the first point, it is the selective importance of information with regard to problem-solving and decision-making processes rather than the amount of potentially useful information available or needed that is critical. A common enough phenomenon is that of being 'snowed under' with information - facts and figures that are potentially relevant to solving the problem under investigation. In this case, it is the selection of qualitatively relevant information that acts as a stimulus in problem-solving and decision-making that is the important factor. Related to this are the practical limits to the amount of information that can be handled and the decision where to draw the line in the search procedure depending on the marginal value of extra information to the problem-solving process (March and Simon 1958). On the second point, it is more likely to be precisely those circumstances in which task uncertainty truly exists, that these 'subjective' factors come to the fore in problem-solving and decisional processes. Information may act as an aide to problem-solving, but decisions may in the end need to be reached according to some more nebulous and subjective formulae. In models of decision-making in complex organisations such as the matrix, such particularistic

facets of 'information-processing' behaviour tend somewhat to be glossed over in the search for a structure that provides a context within which the process as a whole becomes less problematic. It is beyond the scope of this thesis to attempt to devise a more precise formulation of the concepts of task uncertainty, variability, predictability and complexity and to relate these to processes of information flow, or to discuss in any detail decision models based upon these factors. However, it is important to note these limitations: focusing upon outstanding informational requirements can act only as a proxy for the more complex concept of task uncertainty (and related concepts such as variability) and tend to limit the conception of processes of problem-solving and decision-making to a class of activity in which computational formulae based upon 'hard', objective data is the likely norm.

Galbraith's model outlines four basic strategies to cope with greater task uncertainty, each of which have their associated costs and benefits. The first two - creating slack resources, and creating self-contained tasks - are geared towards reducing the level of information-processing needed, and constitute 'defensive' options to cope with increasing levels of task uncertainty, (ibid, Chapter 3). The latter two - investing in informational (computer) systems, and the creation and extension of lateral relations - are geared towards increasing the capacity of the organisation to process task-relevant information. They constitute more of an "adaptive" response to increasing levels of task uncertainty, (ibid, Chapters 4 and 5). It is the latter alternative - creating lateral relations - which forms the basis for the analysis of the more complex structure of roles and relationships found in matrix and related forms of organisation. According to Galbraith, the use of this strategy as opposed to more extensive applications of information system technology is more appropriate when the information required for decision-making is, to some degree, qualitative in form. For the firm operating in conditions in which

the range of inputs and outputs is highly diverse, and where goal performance is problematic and problems and events often unpredictable, he suggests that the appropriate strategic response consists of the promotion of extensive lateral relationships at the technical level. This would allow pertinent information and expertise to be brought in where it was needed, and help achieve the requisite levels of co-ordination or integration between departments, groups or individuals involved in tightly-coupled and interdependent work processes. The mechanisms he suggests to achieve these aims (looked at in more detail below), range from direct contact between line managers and the establishment of co-ordinating committees, through the setting up of ad hoc task force groups or semi-permanent team structures, to the use of more permanent mechanisms. The latter encompass the use of integrators and, finally, matrix organisation (ibid, pp18-19). The fully-blown matrix system involves the legitimisation and explicit structuring of lateral relationships in the form of dual reporting relationships and a corresponding dual control system.

A similarly strong emphasis upon the profusion and legitimisation of lateral relations at the operational level, and its manifestation in the complex dual structural forms that are established or emergent is found in the work of other writers (Kingdon 1973, Sayles 1976, Sayles and Chandler 1971). Kingdon (1973) focuses upon the characteristics of work in more advanced systems, where inputs (eg raw materials) may be diverse and non-uniform, production processes lacking in standardisation and routineness, and where direct 'feedback loops' within the production system itself may be highly extensive (ibid, Chapter 2). He contrasts the technical and social system requirements of this situation - in terms of the boundaries of the task group, the greater

need for self-regulation and mutual adjustment, the wider spread of discretionary activity at the technical level, and the need for lateral interaction and subgroup co-ordination with reciprocally-interdependent tasks (Thompson 1967, p54) - with the constrictions and constraints inherent in a more traditional bureaucratic form of organisation. In particular, he stresses the role of 'technical level' participants in mediating environmental uncertainty in a situation in which the managerial and technical levels of the organisation (Parsons 1960) have become "fused" (op cit, 1973, Chapter 3). In other words, and following Thompson's scheme (1967, Chapter 2), the traditional role of management in 'mediating' environmental uncertainty and 'buffering' the technical system from its effects, becomes no longer separable from the role performed by technical level participants. The two roles are combined as a consequence of dependency upon the information and expertise held by technical level participants and the need for 'within system' management of the production process. This is reflected in a greater degree of participation in decisional processes and more decentralised decision-making authority within the organisation as a whole. His thesis is that the more appropriate form of organisation recognises the inter-relationship between technical and social system characteristics in such a situation, by allowing for the operation of a more 'organic' system of interaction at the operational level. This would involve the recognition of the task group as the basic organisational unit; the spread of participatory influence in decisional processes, with information and expertise rather than positional power forming the basis for authority; the development of relationships based on mutual confidence and trust, and involving 'negotiated interaction' amongst group members; and a greater reliance upon individual responsibility and self-control rather than external control. He

relies then on the criteria specified by Burns and Stalker (1961). Namely:

"The organic form is appropriate to changing conditions, which give rise constantly to fresh problems and unforeseen requirements for action which cannot be broken down or distributed automatically arising from the functional roles defined within a hierarchic structure."

(ibid, 1961, p 121)

Like Galbraith's scheme, the establishment of a 'mixed' or matrix organisational form is then predicated upon the need for the organisation still to fully utilize its human resources, and to provide a framework that allows for internal stability and efficiency in resource allocation (ibid, Chapter 2). According to Kingdon, the adoption of a more 'organic' form in response to complex and uncertain technical conditions serves only to transform the environmental conditions faced by the organisation into less "turbulent" ones, and not to remove the effects of environmental constraints and contingencies entirely. The mechanisms of regulation external to the work group and hierarchical control consistent with a traditional bureaucratic structure are still deemed appropriate in coping with these latter sets of factors - notably internal patterns of resource allocation to achieve efficiency, and ensuring that wider organisational goals are brought fully into decisional processes. Hence the need for a structure that incorporates the dual design criteria of adaptability/operational flexibility and administrative efficiency/functional stability.

The focuses of Kingdon's and Galbraith's approaches differ somewhat: the former focusing upon the set of conditions that might tend to be associated with the implementation and operation of an explicitly-structured matrix form of organisation - using data from a specific empirical example (ie the NASA Apollo programme); the latter adopting a broader approach that attempts to chart the logic

underlying the proliferation of more complex organisational forms that embody a dual design principle - and that may culminate in the establishment of an explicitly-structured matrix form. Nevertheless they and other authors share a broadly common conception of the task characteristics that serve as the defining criteria for the type of situation in which some form of matrix organisation may occur or be appropriate. In particular they identify the complexity and uncertainty of task work performance and high levels of reciprocal interdependence between subtasks. These combine to produce a situation in which there is an inability to preplan work fully prior to task execution and where the high frequency of exceptions occurring and their often lack of predictability, together with problems of 'variance-transmission' (Herbst 1974), require a good deal of information to be processed and a high level of 'negotiated interaction' during task execution (Kingdon 1973, Galbraith 1971, 1973, 1977, Sayles 1976, Sayles and Chandler 1971, Knight 1977). Tight schedules, financial pressures and the importance of 'quality' parameters in the specification of the product combined with tightly-coupled activities place a premium on the avoidance of delays in decision-making and of 'bottlenecks' occurring, such that decisions need to be reached at the point of production and activities need to be conducted in parallel - rather than, say, being able to rely upon inventories of stock or backlogs in production.

They also share a broadly common conception of the requisite structure and processes of interaction at the operational level necessitated by the impact that these factors have upon the managerial processes of planning, co-ordinating, controlling and decision-making. Specifically, that the focal unit within the organisation becomes the

task or project group, comprised of staff from a number of different functional specialisms, whose interaction is intensive and 'negotiated', and where the locus of influence and degree of involvement shifts in relation to changing task requirements. Further, that the structural mode within which this 'organic' task group is contained is one in which decision-making authority is decentralised and where integrative mechanisms are employed to co-ordinate activities. This to achieve a sufficient representation of the interests of these specialists involved, to bring the wider organisational view to bear on decisional processes, and to help overcome the difficulties associated with functional differentiation (Lawrence and Lorsch 1967). In Kingdon's scheme, the appropriate mechanism to achieve 'integration' and to avoid tendencies towards a variety of forms of de-coupling between groups which he terms "segregation"⁷ relies in part upon the establishment of a Project Management function or role. A similar strategy is apparent in Galbraith's and other authors' descriptions of the integrator role (Galbraith 1973, 1977, Sayles 1976, Knight 1977, Lawrence and Lorsch 1967b). The more profound solution, contingent upon task characteristics, is found in the prescription of a fully-explicit matrix structure of roles and relationships.

1.3 Models of Matrix Management

The continuum described by Galbraith (1971) - ranging from pure 'functional' forms of organisation at one end, to pure 'project' forms of organisation at the other - has formed the basis for a more complete categorisation of different models of organisation that exhibit, to varying degrees, the characteristics just described. The now almost traditional grid or 'overlay' (Knight 1977) form of matrix organisation which occupies the midpoint on this continuum, is taken now to represent only one in a number of forms of organisation clustered around the centre of the continuum in which some form of dual management is a prominent feature. Indeed, attempts to describe what a matrix organisation actually is have often been confounded by lack of agreement concerning its precise form or the parameters for defining it. Knight (1976-7), for instance, points to the range of available definitions - from a functionally-based task force system (Miller and Rice 1967, Mee 1964) to project organisation (Argyris 1972, Bergen 1975) - to conclude:

"... overall agreement on the general meaning of matrix is accompanied by a good deal of disagreement concerning its practical embodiments ... there are almost as many individual variants as there are examples."

(Knight 1976-7, p115)

Sayles (1976) has made the additional point that matrix organisation may not be such a new phenomenon, since it often 'evolves' to cope with the need to reconcile differentiation tendencies and the need to integrate activity. Gunz and Pearson (1977) have also noted the possibilities of implicit or incipient forms of matrix organisation, in contrast to the explicitly-adopted ones that have tended to be the main focus of enquiry. In a similar vein other

authors point to long-standing tendencies towards dual management - particularly insofar as the role of professionals in organisations is concerned (eg Eccles, 1975).

Knights' (1977) later work, based on a review of existing theory and empirical evidence, proposes that the important characteristic to consider is instead the occurrence of forms of matrix management (ibid, pp6-7). He distinguishes this by relating it to the existence of some form of organisation in which a dual orientation and associated dual relationships occur. This extends the meaning of matrix organisation beyond that encountered in the traditional grid model, and allows for the comparative description and evaluation of different models of matrix management derived from the multitude of specific instances that comprise the empirical databank for theorists and researchers interested in the form. In employing a continuum of matrix management across which are located several 'pure' forms of organisation, it also allows for the comparative evaluation of tendencies towards one end or the other, in much the same way that Burns and Stalkers' (1966) 'organic-mechanistic' continuum allows for comparison without the need to specify exact location. Knight describes three basic models of matrix organisation arranged along the continuum suggested by Galbraith (1971), and according to the extent to which they represent differences in the 'balance' of influence between project managers on the one hand and functional managers on the other. He labels these as the 'co-ordination', 'overlay' and 'secondment' models, representing increasing levels of project management influence and power within the organisation (op cit, Chapter 10). The 'co-ordination' model corresponds to a situation in which project

staff are formally attached to, and work within, functional departments, but where procedural arrangements are instituted to ensure cross-departmental interaction and collaboration. Task team structures and the role of integrator, or project manager here are relevant, the model encompassing these non-matrix forms of organisation identified by Galbraith (1973). The 'overlay' model corresponds to the textbook version of matrix organisation, involving an extension of the integrator's influence upon task team members to a situation in which dual reporting and control relationships exist. The 'secondment' model is more project-orientated in form - functional departments retaining some direct influence over task team members, but primarily performing a maintenance and service support role within an essentially project-based form of organisation. In this model, the influence of the project manager is extended to more direct line control over project team members. Functional departments provide the 'home base' for staff moving between projects, and undertake maintenance functions for staff involved in projects - such as career training and development.

A comparable, albeit less parsimonious, scheme is suggested by Sayles (1976), who identifies five basic models of matrix management which vary in their degree of "systems" (ie task), as opposed to functional, orientation.⁸ He, like Knight, views the matrix organisation as typified by resource usage observably and directly controlled by two sets of managers (project and functional). He also takes the level of influence exerted respectively by these managers over project team members as the guiding criterion for defining the relative degree of 'systems' or project orientation implicit in the structural form observed. A comparative description

of these models, and their relationships to Galbraith's original continuum is given in Figure 1.1. These approaches add considerably to an understanding of the matrix phenomenon, by allowing for the analysis of relative tendencies, without the necessity of having to relate empirically-derived findings from one particular organisation or setting to the plethora of variants of forms of matrix organisation recorded in the empirical literature. Indeed, Knight classifies many existing, empirically-derived models as 'variants' of his three pure forms: the groups linked by project stages described by Bergen (1975), and Kingdon's 'work package' system he categorises as variants of his 'co-ordination' model - their common characteristic being the secondary position of project managers with respect to their functional counterparts; the grid organisation with members performing dual roles (Gunz and Pearson 1977), and Videlo's (1976) 'functional overlay' model he categorises as variants of the 'overlay' model - the common characteristics being a balanced orientation towards functional and project goals, with equality of influence and patterns of dual accountability; Kingdon's (1973) 'body shop' arrangement and Videlo's (1976) functionally-located project task teams he categorises as variants of the 'secondment' model - here primacy is attached to project objectives, and the influence of project managers is more extensive than that of their functional counterparts. In all accounts, it is the comparative influence of project and functional managers over project team members and their roles in this respect that form the nexus in the continuum of matrix types. Sayles (1976) for instance, describes seven basic managerial roles performed respectively by the two sets of managers to varying degrees across the spectrum of matrix management forms. These are operating responsibility, stabilising

Figure 1.1 A Comparative Outline of Models of Matrix Management *
 *(Based upon the continuum suggested by Galbraith (1971))

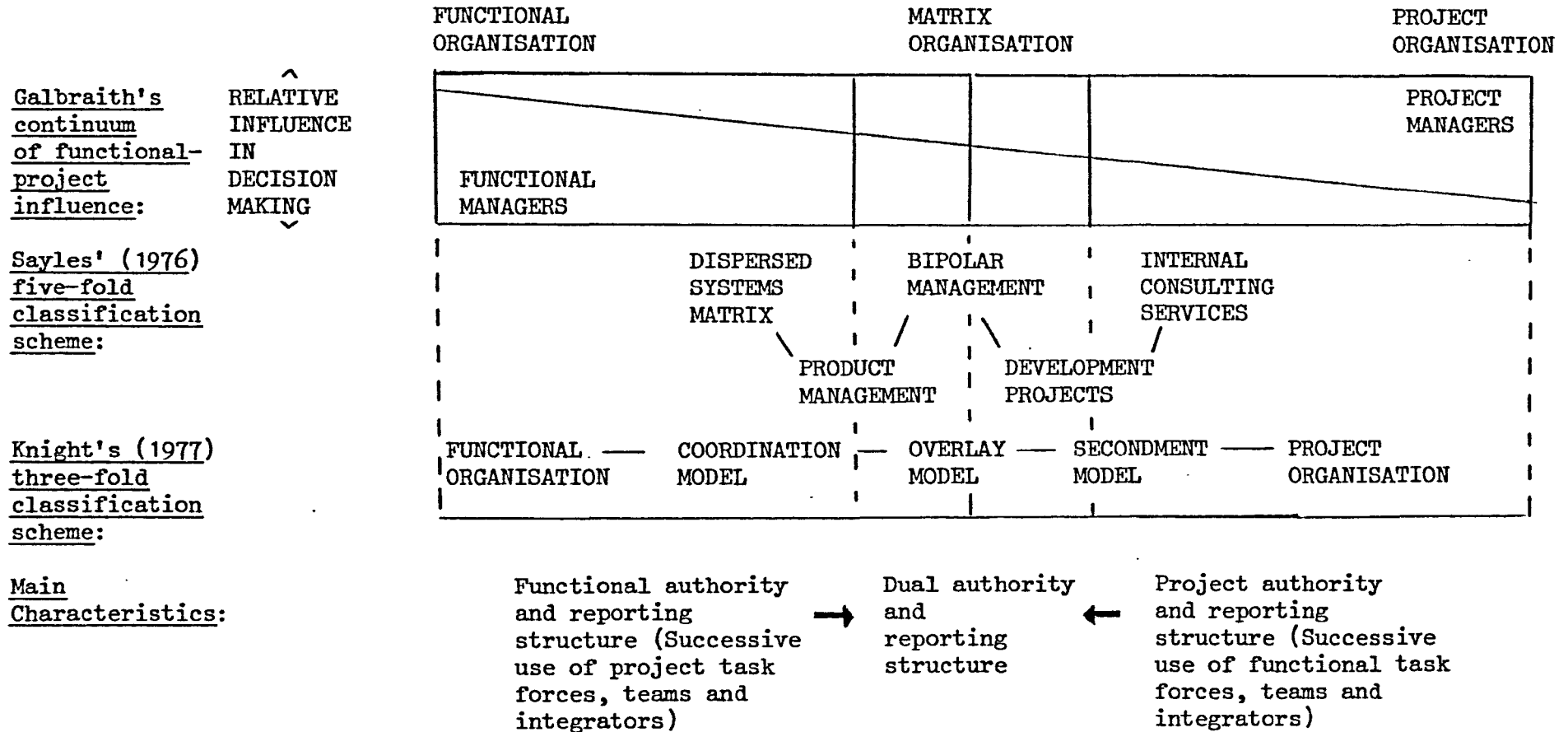

(ie responsibility for approving certain technical decisions), auditing performance, offering technical advice, providing centralised support services, liaising between groups, and institutional management (or 'maintenance'). Thus, for instance, in a 'co-ordination' model setting, functional managers would retain operating responsibility and perform most of the remaining functions, the project managers primarily being involved in auditing project performance and liaising, or acting as intermediary and co-ordinator between groups.

Knight's definition of a matrix organisation - like that of Sayles (1976) - is consequently more wide-ranging than that supplied by other authors who focus primarily upon the 'overlay' or grid structure (Galbraith op cit, Kingdon 1973, Mee 1964, Davis 1974, Drucker 1974). In defining matrix management he focuses upon the descriptive characteristics central to the operationalisation of the concept (ibid, pp6-7). Like all authors, he identifies some degree of dual line authority and/or direct influence over project team members as evidence of its existence. 'Functional authority' relationships (cf Koontz and O'Donnell 1980) would be included in this definition. However, the exercise of 'staff' authority would be excluded, since the exercise of influence based upon advice or information without the authority to prescribe courses of action does not constitute direct influence in the manner typified in traditional line relationships. Indeed, some authors have gone further, by suggesting that 'staff' roles and relationships as traditionally defined are not applicable to the characteristics of the types of organisation described here (eg Lawrence and Lorsch 1967, Davis 1974). Secondly, Knight suggests that, while dual authority and accountability relationships are necessary in any operational definition, they are

not a sufficient condition for describing a matrix: there needs to be some difference in the organisational basis underlying dual group membership (eg specialisation by function and by project). Thus, he defines the central criterion for identifying a matrix as being evidence of a two-way division of labour, where team members are involved in two separate sets of activities: the one connected with their role within the project team; the other connected with their functional role. The remaining characteristics he cites relate to the task group being identifiable as the basic organisational unit - such that the project or task determines the boundary for the group (Miller and Rice 1967); and the performance of the task involving concurrent and lateral interaction in working relationships amongst group members.

1.4 Themes from the Literature upon Matrix and Project Management

Research into forms of matrix management in project settings has focused upon a number of broad themes. Most notably these have been: the relationship between the task group and the wider organisation; characteristics of roles and relationships amongst members of the task team, and the specific problems associated with the operation of a form of organisation in which some form of dual management is the norm. The focus has been upon patterns of communication, co-ordination and control; and upon processes of influence in a variety of forms in problem-solving and decision-making activity. The aim of this section is to provide a brief overview of these themes and to highlight consistencies and contrasts in the literature.

1.4.1 Team Relationships

The first series of points to be made concern the issues noted with respect to less explicitly-structured models of matrix organisation than those described above. In particular, the problems of co-ordination and control for the organisation associated with the establishment of inter-disciplinary and/or inter-departmental task forces or teams are seen both to offer insights into the types of problems encountered in more sophisticated organisational forms, and also a rationale for the adoption of a matrix form that is more explicitly-structured. The processes of co-ordinating and controlling inter-group activity and the effects of goal and power differentials between subgroups based in various departments has received considerable attention in the organisational literature (eg Lawrence and Lorsch 1972, Pfeffer 1981). Herbst (1974), for instance, has noted that the degree of "disruption" in working relationships is not only determined by the "work relationship

pattern" (which he defines as the activity relationship, role differentiation and degree of task dependence), but also by characteristics of the goal-dependence relationship between groups: ie whether goals are shared, independent or 'unreciprocated supporting'. Thus, in a situation of task interdependence but independent goals, the relationship will be inherently unstable (Herbst 1974, p120).

With respect to the impact of such factors in complex task environments, Lawrence and Lorsch's (1967) concept of "differentiation" and the observation of the differential impact of the task upon role-holders' power in interaction (Crosier 1964, Thompson 1967) have formed the bases for more extended accounts of the processes involved, and the problems encountered, where "negotiated interaction"(Kingdon 1973) amongst task team members becomes prerequisite. In such settings, difficulties in lateral contact and communication (eg withholding information, not understanding others' positions, competition, etc) have been well documented occurrences (Kingdon 1973, Sayles and Chandler 1971). Related research has also pointed to the effects of status barriers in reducing "team effectiveness" (Bridges et al 1968); and the problems of commitment associated with interdepartmental teamwork (Weiner 1970, Schein 1970). Research has further studied the problems for the individual suggested by the potential disparity between task and 'sentient' group boundaries (Miller and Rice 1967); and the associated problems of reduced peer group interaction and the potential for 'professional obsolescence' engendered by the closer association with the task, as opposed to the professional/functional, group (Allen and Cohen 1969, Kingdon 1973, Sayles and Chandler 1971). At this point it should be stressed that such problems are taken as not necessarily specific to forms of matrix or project organisation, but

characteristic of a wider range of circumstances in which lateral interaction or co-ordinated collateral working relationships occur. At the same time the contexts of matrix and project management have been particularly identified as those types of situation in which such problems would tend to be more widespread and endemic.

Galbraith's (1973, 1977) model supplies perhaps the clearest exposition of the impact of a situation in which the tasks to be performed are complex and uncertain; the problems to be solved are in large part unpredictable and "unstructured" (Simon 1960); and where they require the participative interaction of specialists, each of whom may hold different professional perspectives and orientations (Lawrence and Lorsch 1967). He bases his distinction between team structures and integration/matrix management as means of coping with increased task uncertainty, on the proposition that higher levels of task uncertainty are associated with a differential impact upon subtasks which, therefore, affects the basis of the relationship between role-holders within the task group. This effect occurs both through differences in attitude or orientation associated with functional and role differentiation; and through differences in the "power" of individuals or groups that also arise (Galbraith 1973, Chapter 7). With respect to the latter, he focuses particularly upon the greater relative power in interaction of individuals and groups performing "uncertainty-absorbing functions" (March and Simon 1958, pp164-6, Simon 1960, Thompson 1967) as leading to a situation in which the expert (French and Raven 1959) or informational (Pettigrew 1972) power exerted by them produces an imbalance in decisional processes and processes of co-ordination and communication and a tendency for decisions to be reached that

reflect narrower subgroup goals - rather than wider organisational goals with respect to the task being performed.

If these factors are neither widespread nor significant, then Galbraith (1977) proposes that "effective" decisions can still be reached, and "information overload" kept to a minimum in the event of disagreement, within an essentially team-based structure. In such an event the team is left to reach its own decisions and resolve its own disputes, in which case a "bargaining" framework for interaction may emerge. A heavy reliance will also be placed upon the guiding influence of "unobtrusive controls" which control the premises for decision-making (March and Simon 1958, Simon 1965 p79, Perrow 1979 p149), and norms of interaction or a 'climate' of decision-making which is conducive to such processes.⁹ He also describes more "obtrusive" mechanisms within the team-based setting aimed at controlling the large quantity of decisions taken at lower levels within the organisation, easing the processes of lateral interaction, and ensuring that the organisational viewpoint is brought into decisional processes. Firstly, that the team must obtain approval or ratification for decisions reached from a higher status individual (or group), who would also act as arbitrator in settling intra-team disputes. Secondly, that the "leadership" of the team would rest formally or informally with the individual group or section within the team whose goals were most congruent with the task goals being pursued (Galbraith 1977, pp126-7). Galbraith suggests two possibilities here: either the informal leadership function resides with the 'core' function - in civil engineering projects, for instance, this may be the design engineering staff; or it may pass from department to department as the range of relevant task conditions

alters. (Taking the same example, design engineers may pass over to construction engineers the role of "leadership" as the project moves from the drawing board onto the site.) Galbraith compares all these options with respect to their implications for the process of decision-making in which "forcing" a decision may occur. He (like other authors) describes this as a "sub-optimal" form of decision-making and conflict resolution in comparison with the more collaborative and co-operative style leading to solutions based on consensus deemed "optimal" in an organic context (see also Sayles and Chandler 1971, Kingdon 1973, Thamhain 1977, Thamhain and Wilemon 1975). However, in the case of decisions 'forced' by one 'senior' individual or group whose goals most reflect those being pursued or whose contribution is more central, he regards this as preferable to the greater disruption that might otherwise occur. The more basic assumption here is that the existence of shared values, goals, orientations and power will serve to minimise the likelihood of such disputes and disagreements occurring. Or they will at least enhance the likelihood of their being resolved 'effectively'. However, it is the more disruptive tendencies associated particularly with the differential impact of the task upon role-holders' power - and its association with increasing levels of task uncertainty and interdependence - that Galbraith views as prompting a move to more explicit structural mechanisms: ie the use of integrators and, ultimately, matrix organisation.¹⁰ Differential goals, orientations and even values are seen to be compounded by the effects of subtask uncertainty upon the respective power of subgroups such that more explicit mechanisms of co-ordination and control are deemed suitable.

1.4.2 Integrators

Integrating roles are not an entirely new phenomenon. Indeed,

many of their attributes are similar to more traditional roles such as "chairperson", or "teamleader" (Patterson 1966). The distinguishing feature in more contemporary analyses of complex organisations has been the emphasis put upon integration as a specialist function in itself - rather than as an adjunct to a more generalist management role (Lawrence and Lorsch 1967b, Maier 1967, Galbraith 1977, Knight 1977). Integrators (variously called 'project', 'product' or 'unit' managers), are appointed independently from those departments whose work is to be co-ordinated. They are given the authority, and are held accountable, for the co-ordination of task and organisational work across departmental boundaries. However, they do not possess the formal authority to direct the work of those who actually perform the tasks themselves. Instead they act as 'facilitators' or 'catalysts' or 'gate-keepers'. Wilemon and Gemmill (1971) have described them as being essentially "boundary dwellers". Sayles (1976) has described them as "decision-brokers".

Research interest has centred upon the relationship between those occupying the role of integrator and functional managers and staff, and, in particular, upon the bases of influence available to integrators given their comparative lack of formal authority with respect to functional managers. There is a general consensus on the types of influence or power associated with the effective performance of the integrator role. In particular the use of expertise (French and Raven 1959) and access to, or control over, relevant information (Pettigrew 1972) have been suggested as the principal requirements for the effective performance of the integrator role in the absence of positional authority (Lawrence and Lorsch 1967b, Maier 1967, Wilemon and Gemmill 1971, Sayles and Chandler 1971).

The presence of an integrator, particularly one who knows the workings of the 'uncertainty-absorbing function(s)' is seen as helping eliminate the possibility that someone with access to knowledge and information can use it as a source of power in bargaining (Lawrence and Lorsch 1967b, Galbraith 1977). Furthermore, interpersonal skills and influence based on referent power (French and Raven 1959) are also deemed to be pertinent bases of influence, by virtue of helping to ensure that confidence and trust in joint decision-making is achieved (Lawrence and Lorsch 1967b, Maier 1967, Sayles and Chandler 1971).¹¹ In the absence of concensus or in the case of disagreement, the integrator is seen as the individual who may help in the achievement of compromise solutions (Kingdon 1973).

Such an emphasis on bases of influence other than formal position power, reflects both the comparative weakness of the project manager's formal position vis-a-vis functional managers, but also the need to establish a role whose occupant has sufficient influence such that a 'balance' of influence (Davis 1974) between project and functional goals can be achieved. According to Knight, this does not represent the establishment of a 'power' equilibrium based upon formal authority, except in the very limited case of a pure 'overlay' model. Rather, it involves relating the effective influence vested in the respective roles to the aims to be achieved (Knight 1977, ch. 11).

Knight suggests that the formal authority of the respective managers will be distributed across the roles in proportion to the importance of the respective subgoals (Knight 1977). The problem then is in establishing comparative total levels of influence based upon criteria

other than formal position which help ensure both that the comparative levels of influence correspond to the dual aims to be achieved, and that power imbalances do not adversely affect interaction processes. This in a 'pluralistic' setting (Sayles 1976), in which negotiation and bargaining may occur extensively.

1.4.3 - 'Leadership' in Matrix Management Settings

In focusing upon the role of integrator in a project setting, a good deal of explicit and implicit attention has been given to their role as 'leader' of the task team group. Generally, the integrator is seen as a facilitator of interaction: one who allows the expression of different groups' opinions and views; who encourages participative influence based upon the possession of relevant knowledge, expertise and information; who has sufficient knowledge and awareness to understand others' positions and views, but not such as to dominate discussion. Above all, someone whose positional authority is low relative to that of other functional role-holders, and who exercises influence based upon dimensions other than that of formal authority (eg Galbraith, op cit).

If one were to compare these stylistic dimensions with those identified in the theory and research on leadership in formal organisations, one would tend to associate them with a set of behaviours that emphasise participative approaches (eg Yukl 1971, Vroom and Yetton 1973); interaction facilitation (eg Bowers and Seashore 1966), or, more generally, "group maintenance" (eg Halpin and Winer 1957, Katz and Kahn 1951, Bales and Slater 1955); an emphasis upon interpersonal skills and orientations - or more broadly 'consideration structure' or 'supportive' and 'motivational' styles (eg Hemphill and Coons 1957, House and Mitchell 1974); and an approach that emphasises goals and goal achievement (eg Halpin and Winer 1957, House and Mitchell 1974, Bowers and Seashore 1966). This in contrast to a style or approach which is more directive, instrumental or authoritarian (eg House and Mitchell 1974, Vroom

and Yetton 1973), and where initiating and structuring activities and playing a significant part in the input of technical expertise are important characteristics (eg Bowers and Seashore 1966, Likert 1961, Hemphill and Coons 1957, Fleishman 1973). The exercise, however, is a difficult one, since organisational research into forms of matrix and project management is not particularly well-integrated with the field of leadership theory and research. In other words, the discussions just described are rarely articulated in any operationalisation of the concept of 'leadership' as applied to the processes involved in such complex settings. This is not a problem specific to the study of matrix management: indeed, recent calls have been made for a much closer integration in general of organisational and leadership theory and research (Dubin 1979, Melcher 1977). It is not the intention here to attempt to achieve this integration. Nor to attempt anything but the most generalised and superficial review of the vast literature upon leadership in organisations.¹² However, it is useful to address some of the central issues raised in that extensive body of work since, it is argued here, they have important implications for studying the behaviour of integrators and the processes of 'leadership' in which they are involved in the type of setting that is the central focus of this study.

A consideration of stylistic differences on the part of managers in de jure leadership positions and their impact upon group performance and subordinates' satisfaction has dominated the field of leadership and research since the 1940's and 1950's (see Kerr et al 1974, Fleishman 1973). Further, since the seminal work of Fiedler (1967), a consideration of the impact of contingency factors in

moderating this broad relationship between leaders' styles and group/individual outcomes has played a central part in an understanding of leadership processes in organisational settings.¹³ The history of leadership theory and research has been dogged by problems of conceptualisation, operationalisation and measurement - manifested in the lack of any generally-held current theory to explain leadership processes, and often confusing and contradictory results (see Bryman 1986, Stogdill 1974).¹⁴ However, most current competing models share certain broad characteristics and assumptions. Firstly, the lack of any firm and direct association between leaders' traits and performance (Stogdill 1948). Secondly, the importance of 'followers' to an understanding of leadership processes (eg Yukl 1971, House and Mitchell 1974). This approach has been taken furthest in current studies of leadership based upon dyadic interactions (eg Graen and Cashman 1975, Dansereau et al 1975); and in the "path-goal" model wherein subordinates' expectations play a crucial part in understanding the motivational processes underlying leadership effects (House and Mitchell 1974, House and Dessler 1974). Thirdly, the importance of other situational variables (eg task complexity, position power, etc) as moderating factors in the potential association between leader behaviour and group/individual outcomes (Fiedler 1967, House and Mitchell 1974, Vroom and Yetton 1973). This approach finds its fullest realisation in the recent interest expressed in factors that contribute towards a certain degree of 'situational control' and thereby act, in effect, as "substitutes for leadership" (Kerr and Jermier 1978). As a broad working definition, leadership is conceptualised as a process of influence geared towards the attainment of group goals. Central to an understanding of the processes involved is the concept

of motivation: specifically an understanding of followers' perceptions and expectations (Vroom 1964, Lawler and Porter 1967) in relation to the intrinsic and extrinsic characteristics of the task being performed (Herzberg 1959). Also crucial is an understanding of the contingent impact of leader behaviour relating to characteristics of the setting in which leaders and followers interact. It is to a consideration of this latter set of factors in particular in a complex and uncertain project setting that this discussion now turns.

The first point to be made is that the discussion of the requirements of the integrator in exercising leadership in a project setting owes much to the model proposed by Blake and Mouton (1964) in their "managerial grid" (in many instances a discussion of the orientation of project managers is in fact based directly upon this framework). The implicit (and often explicit) expectation is that effective integrators exhibit both a high 'concern for results' and a high 'concern for people'. In other words that they are both strongly task-oriented and strongly relationship-oriented (Fiedler 1967). If this is the case - that a "9,9" score (Blake and Mouton 1964) is the more appropriate - then one needs to ask to what extent this is possible, or even desirable, given the difficulties and inconsistencies reported in trying to achieve this state (Larson, Hunt and Osborn 1976, Nystrom 1978), and also general tendencies in the literature to regard these orientations as to some extent mutually exclusive (Fiedler 1967). Given in addition the difficulties in assuming any direct association between orientational predisposition and actual stylistic behaviour

one has further to ask in what way such orientations are translated into forms of behaviour that facilitate interaction. The matrix and project management literature is relatively clear on what the integrator is expected to do. However it is rather less so in linking what they actually do with the outcomes that are likely to be achieved given the circumstances faced.

If the earlier interpretation of the appropriate 'styles' of interaction necessary is correct, then more extensive consideration needs to be given to these circumstances and their implications. In particular, if one accepts the importance of situational factors as moderators of the association between leader action and group performance/satisfaction, then the possibility is raised that what are deemed appropriate or requisite forms of behaviour are either inconsistent with the circumstances faced or, in practice, unlikely to achieve the results expected. Fielder's (1967) early contingency model, for example, related the efficacy of a task or relationship orientation to the degree of 'favourability' in the conditions within which formal leaders were expected to operate. The dimensions he looked at in this respect were the level of structuring of the task, the leader's position power, and the quality of leader-group relations. His findings, developed in later research,¹⁵ were that leaders operating in highly favourable or highly unfavourable circumstances would tend to be most effective if they were task-oriented; while relationship-oriented leaders would be most effective in moderately favourable conditions. Low favourability here would be associated with a relatively unstructured task, low position power and poor group relations. With the exception of this latter dimension, what is interesting about this model is the extent to

which the dimensions of 'unfavourability' correspond to precisely the types of circumstances found in a matrix setting. Task complexity and uncertainty, of course, are the raisons d'etre for such models. Lack of position power correspondingly becomes the requisite modus operandi. For instance:

"Problems of motivation exist for the traditional vertical manager, but these problems are compounded for the Project Manager because the traditional leverages of hierarchical authority are not at his disposal ... In the project environment, the real basis of a man's authority is his professional reputation among his peers and associates ... his authority is a combination of de jure and de facto elements in the total project environment ... (actual project authority is) the legal and personal influence that the Project Manager exercises over the scheduling, cost and technical considerations of the project."

(Cleland and King 1975, pp302-5)

If one accepts Fiedler's findings then, in contrast to expectations, a more directive approach in such circumstances would perhaps appear to be the most likely to achieve effectiveness. Fiedler's research has long been the subject of intensive debate: centring largely upon the meaning and hence validity of the technique (the "Least Preferred Coworker" scale) used to measure leader orientation (cf Schreisheim and Kerr 1977). Consequently, the research has been heavily criticised on conceptual and methodological grounds, although a recent review has lent some support to the consistency and credibility of the overall model and its results (Strube and Garcia 1981).

Less controversial leadership models, however, have similarly focused upon the impact of task, structural and group situational

conditions. The more precisely-formulated "path-goal" theory of leadership (House and Mitchell 1974, House and Desslet 1974) contains similar, albeit more sophisticated, hypotheses. Namely, that given subordinates' expectations, certain types of less favourable conditions (eg high task complexity, high role ambiguity) may promote the efficacy of a more 'directive' or 'initiating' style of leadership. The somewhat particularistic normative model of Vroom and Yetton (1973), which focuses upon the participative dimension in decision-making, adds a further two factors of interest here. As well as identifying task characteristics and their implications for the reliance of the formal leader upon the expertise, knowledge and information provided by subordinates, they also identify the amount of time available as a significant constraint, and also the extent to which acceptance of decisions by subordinates is an important factor. Interestingly, the amount of time available is regarded as a significant constraint upon the exercise of participatory influence. In a project environment, where deadlines are tight, and decisions need to be made quickly, such a factor may be of enhanced importance in constraining the ability of the 'leader' to act in what are deemed to be more appropriate ways. The likelihood of acceptance, on the other hand works the other way: the more important it is to gain acceptance (a factor made salient in a matrix or project management setting) the more appropriate is a more participative, and less directive or 'autocratic', approach. Vroom and Yetton (1973, pp26-7) identify four acceptance factors (the criticality of commitment to decisions; the prior probability of acceptance of autocratic decisions; subordinates' motivation with respect to task goals; and subordinates' disagreement over means) and suggest generally that:

"Acceptance becomes more critical as the effective execution of the decision requires initiative, judgement or creativity on the part of subordinates, or when one or more of the conditions necessary for obtaining compliance breaks down."

(ibid, p27)

The characteristics of the situation in a matrix setting clearly puts a premium upon the importance of acceptance - or rather, the extremely low prior probability that autocratic decisions taken by the integrator will be accepted:

"It is this balancing act, by which technical decisions are made to reflect multiple considerations that takes most of the Project Managers time ... (it) requires a capacity on the part of the manager to put together an organisational mechanism within which timely and relevant decisions are likely to be reached, a conceptual scheme for "working" interfaces and for predicting where structural changes should be introduced if the response is inadequate, untimely or insubstantial. This is a highly dynamic, interactive, iterative and intellectually challenging concept of the managerial role ... But for the most part he does not operate the structure; operations are handled by a variety of functional, live technical and contractor groups."

(Sayles and Chandler 1971, pp208-12)

If it is possible to equate the performance of the integrator role with the phenomenon of leadership in a project setting, then the centrality of acceptance alone would provide a sufficient basis for the expectation that, generally speaking, a more participative style or approach would be appropriate to the achievement of objectives. The relative functional autonomy and independence of team members (and their leaders) suggest the necessity and desirability of a style of interaction that tends towards this end of the leadership nexus.

It is not the intention here to attempt to supply a broad framework for the integration of the models of leadership processes just described. The aim is rather to assess the implications of such contingency factors to the study of leadership processes in a situation - ie, a matrix setting - in which these factors are generally held to be highly salient characteristics. The first point to be made here, is to note the possible contradictions facing the integrator in the performance of the 'leadership' role. One might suggest that the types of conditions described are highly 'unfavourable'. To the extent that the necessary degree of acceptance required is high (and also lack of position power and a reliance upon team members' expertise), then one would expect the stylistic recommendations that pervade the matrix management literature to hold. On the other hand, however, other characteristics of the situation - particularly tight deadlines, high task complexity and role ambiguity or conflict suggest the possible efficacy of an alternative, more directive style or approach. The variety of models that exist in the diverse body of literature on leadership, makes it difficult to provide more precise, detailed and clear cut propositions concerning the likely outcome of leader behaviour. However, it should be apparent that the degree of variability in these situational conditions (both across and within the distinct dimensions identified) do make for a potentially more complicated understanding of the effects of different styles of interaction in the variegated (and changing) conditions that are faced. More specifically, for example, is the tendency towards a more 'participative' style (deemed necessary and desirable) in fact problematic when one considers the limits to the time available, the lack of a sufficiently

high degree of task structuring, and high levels of role ambiguity and/or conflict? If these factors are pervasive and salient (and the matrix management literature suggests clearly that they are), and to the extent that there is some inconsistency between styles of interaction (Nystrom 1978), then one would expect contradictions to emerge in the integrators' performance of their 'leadership role' or in the effects of specific styles or approaches. At least one might expect some situations to arise in which preferred styles or approaches are either inconsistent with what is possible or what is required. In the constellation of factors that promote the efficacy of one type of approach or another, one might expect, depending upon specific circumstances and changes over time, that the more 'effective' integrator is one who is able to adapt and respond to these conditions - acting as a leadership 'chameleon', rather than maintaining a consistency in approach.

The point here is not that the matrix literature is short on specifications of what types of behaviour are required in such complex settings. The literature is full of such specifications. The problem is that there is a tendency to address these requirements as a 'blanket' set of criteria, despite the potential effects of significant variation in circumstances (eg whether deadlines are 'tight' or not), and change in these circumstances over time (eg given variation over the course of the project cycle). For a body of literature that emphasises a contingency approach, it is quite surprising to find that there is little systematic attention directed towards the potential impact of variation in contingencies in the study of leadership processes

in such complex settings. Such an omission would be acceptable if one were able to assume broad similarity across the types of situation investigated (and over time).¹⁶ However the broad array of models of matrix management suggest this is not so. Moreover, the dimensions which form central planks in contingency models of leadership processes are precisely those dimensions that are the salient features in the move between one end of the matrix management continuum and the other. For example, differences between a 'co-ordination' and 'overlay' model may include higher levels of role ambiguity and conflict, greater project manager position power and a lower emphasis upon the need for acceptance (as opposed to compliance based upon authority) in the latter model as opposed to the former. While such variation is taken to correspond to significant differences in influence processes (including leadership) within the organisation, any potential qualitative impact upon the efficacy of different styles of interaction tends to be ignored. For example, as one moves towards an 'overlay' model, the importance of 'acceptance' may diminish as the integrators' relative influence increases, while levels of role ambiguity in a dual reporting system may increase. Other things being equal, one might expect this to put a premium upon a more 'directive' or 'initiating' approach adopted by the integrator in interaction.

The general point to be made here is that a broad concern in the literature with the complex and dynamic leadership role performed by the integrator in the range of settings in which some degree of matrix management is the norm, is offset by the tendency neither to address systematically the potentially diverse impact of the array

of dimensions that are salient, nor their variation across the range of settings described. A second general point to be noted, and one hinted at in the above quotation by Sayles and Chandler (1971), concerns the impact of such factors when an external, as opposed to internal, matrix system of roles and relationships is the focus of interest. This point will be returned to in more detail in the following chapter.

1.4.4 Dual Authority and Control

As noted above, matrix organisation itself constitutes a further extension of the influence of integrators or project managers, such that dual authority and accountability relationships are formally recognised and legitimised. What is particularistic about the classic matrix form is the way that it structurally embodies the conflict of interest inherent in a dual and balanced orientation towards project and functional objectives. The conflict is internalised rather than resolved, and manifested in the violation of the unity of command principle deemed essential since Fayol. Consequently, the resolution of conflicting objectives of adaptation and flexibility - of project integration and functional differentiation - provides not only the raison d'etre of the matrix form, but also its main problem. Knight (1977) indeed views this dual structuring as the inherent problem of matrix organisation as such. Other issues - ie (the bases and balances in influence and authority, conflict in relationships and problems in decision-making) - constitute in his scheme non-inherent problems. They perhaps vary in degree and intensity compared to those described in less complex settings, but not in basic type. In practice he notes the tendency for problems to be resolved by 'tipping the power balance' one way or the other: a tendency which means the loss of the potential benefits of a balanced dual structure. (Knight (1976-7) points to Kingdon's descriptions of the 'job shop' and 'work package' as illustrations of this tendency.)

The consensus in the literature is that the norms relevant to an 'organic' model of organisation pertain: not only in an explicit matrix form, but also in the less complex settings that have already been described. Briefly, these include: an emphasis upon network patterns of communication and lateral, 'negotiated' interaction; the replacement of the norm of influence based upon role and position power with one in which influence is based upon expertise and the possession of information relevant to problem-solving and decision-making processes; involvement in organisational work with respect to the part played in the processes rather than the role of the individual, given unclearly defined jurisdiction (Kingdon 1973, Galbraith 1977); the adoption of a collaborative, as opposed to competitive, collusive, authoritarian or withdrawing stance in interaction; the assumption by individuals of a level of responsibility that exceeds their manifest, formal position power; and the acceptance of conflict in organisation relationships.¹⁷ At the same time the research undertaken (eg Kingdon 1973) points to the widespread problems in lateral interaction that tend to occur in such settings, and the difficulties in practice of maintaining such a form in which these norms can be achieved and successfully maintained. For the individual who is involved in this type of arrangement, the findings point consistently to, on the one hand, the positive benefits for job satisfaction stemming from wider participation and influence in the task (eg Argyris 1971); but, on the other, the heightened potential for stress and anxiety. This latter is related to both the assumption of a level of responsibility greater than the level of authority available to them, and the peculiar characteristics of a dual structure in which role ambiguity and role conflict (Kahn et al 1964) are potentially pervasive characteristics.

Indeed the main thrust of the findings from studies of matrix and related forms of organisation relate to the individual's tolerance for, and acceptance of, uncertainty, ambiguity and conflict (Brayfield and Crockett 1955); and to the organisation's existing cultural norms as conditioning factors in the implementation and operation of a matrix form. Kingdon's (1973) central conclusion, for instance, is that a matrix form means a greater diffusion of responsibility among organisational members for task performance, but that there are strong forces that tend to (vertically) segment and (laterally) dissociate important task relationships within the organisation.¹⁸ He focuses upon the 'social sophistication' required of organisational members in such settings, and his broad longer-term solution is given in the establishment of "management and organisational development" strategies aimed at adjusting the existing climate of interaction or the prevailing cultural norms associated with a more traditional form of organisation to one consistent with the new type of setting. The importance of such strategies, together with participative approaches in implementation and structural change is similarly emphasised by other authors (Argyris 1967, 1971, Sayles 1976, Galbraith op cit). The aim being to foster the shared values, mutual understanding, openness and collaborative stance felt by Kingdon to be the appropriate norms (ibid, Chapter 3). The problems of implementation due to both the inconsistencies of styles adopted to manage the new form and the encountering of resistance in its introduction are focused upon by Argyris in particular (1967, 1971):

"... the basic problem has been that a new form of organisation has been introduced in such a way as to make difficulties inevitable, and that the leadership styles that executives use to administer matrix organisation, on the whole, compound the felony."

(Argyris, 1967, p 34)

While the more general issue of cultural inconsistency is described well by Sayles (1976):

"Most traditional managers are accustomed to well-defined tasks, single goals or goals that are multiple but compatible, clear and well-guarded jurisdiction, and requisite authority flowing from fixed plans. Matrix management, by contrast, is concerned with managers whose authority is limited in comparison with their responsibility. Matrix management leads to overdefined jobs in which there are more requirements than can possibly be met and conflicting goals that make trade-offs between them continually necessary."

(Sayles 1976, p16)

Such factors make the introduction of the form contingent upon the nature of the pre-existing organisational culture (Kingdon 1973, Galbraith 1977, Knight 1977).¹⁹ According to Knight:

"It is a form of organisation which provides more scope than most, both for conflict and stress and for personal committment and creative collaboration. Much may depend on the existing organisational culture and on the ways in which the structure is introduced and operated."

(op cit, p 135)

The theme of cultural compatibility or incompatibility is perhaps most systematically explored by Knight (1977). With recourse to Handy's (1976) three-fold classification of cultural types (ie 'task', 'role' and 'power' cultures), he argues that existing 'task' cultures are those most conducive to the introduction and operation of a matrix scheme, and that organisational development approaches to its implementation and operation are only necessarily applicable in a situation in which levels of authority and responsibility are left relatively undefined. Relating the pre-existing cultural 'type' to his three models of matrix management he suggests a number of possibilities. Thus, for instance, organisations with 'role cultures' will require a clear definition of authority, and accountability relationships in a matrix 'overlay' to facilitate

interaction. He, like Kingdon and Galbraith point here to the use of social analysis techniques in implementation (Rowbottom 1977) and/or to some form of descriptive/prescriptive mechanism such as "responsibility charting" (Melcher 1967, Perham 1970, Cleland and King 1975). 'Power cultures' he suggests will be more conducive to the establishment of bases of influence other than position power, and consequently more suited to the move towards a 'co-ordination' model; 'task cultures' will be more appropriate to task-based systems, and hence suited to the 'secondment' matrix model.

To sum up briefly, there are two major points to be raised here. The first is that there is general agreement that problems in the implementation and operation of a matrix-type system are to some extent contingent upon the prevailing cultural characteristics of the organisation. Views vary on the extent to which adjusting to the existing situation or implementing a programme of change that also seeks to change preconceptions are appropriate strategies. However, the potential for a 'clash of cultures' is generally recognised. The second point is more general, and concerns the broad observation that the successful operation of a matrix-type system relies extensively upon behaviour within that system. While a dual structure of management provides the context within which work is performed and decisions are taken, it is the reliance upon individual and group behaviour within that context that is the central characteristic in the operation of a dual system.²⁰

Footnotes

- 1 See Sayles and Chandler (1971), Kingdon (1973), Wilemon and Gemmill (1971), Thamhain (1977), Thamhain and Wilemon (1975), Wilemon (1972), Wilemon and Cicero (1970).
- 2 The list could be extended by the inclusion of other bases; eg client-basing. For a fuller list of alternatives see, for instance, Koontz and O'Donnell (1980).
- 3 The association of the matrix form with high technology endeavours has led it to be included amongst those described in writings on 'contemporary' - ie late 20th century - types of organisation (Drucker 1974, Argyris 1967). Many of the characteristics of this form, discussed below, compare closely with those described and prescribed for organisations 'of the future' (Bennis 1966). For a more down-to-earth review of the form and its location in the spectrum encompassing classical bureaucracy (Weber 1947) and 'adhocracy', see for example, Mintzberg (1979).
- 4 The earliest statement of this approach was given by Woodward (1958) who, on the basis of findings from 100 manufacturing firms based in south-east England, differentiated according to their type of production system (unit and small batch; large batch/mass production; process production) concluded that "There can be no one best way of organising a business" (ibid, p10), and that the effective organisation of work was contingent upon the production technology employed. This was in contrast to the school of thought that held that organisational principles were applicable to any situation (eg Fayol, Urwick, Gulick and Brown); and in response to the identification of the universalistically applicable classic bureaucratic form (Weber 1947). This work, and subsequent developments (notably the Aston research programme begun in the late 1960's), will be returned to below.
- 5 His later work (1977) extends the approach from a consideration of structural design to the design of sanctioning and information systems.
- 6 For a more detailed but concise description of the range of characteristics of the 'mechanistic' and 'organic' models see Burns (1963, pp46-7).
- 7 Kingdon (1973, Ch 4) identifies three forms of 'segregation' which he defines as "maladaptive" models of behaviour in complex organisations and which he relates to the tendency for organisational, group and individual goals to diverge: firstly, "segmentation" - an attenuation of links between different levels of the managerial hierarchy; secondly, "fragmentation" - where ends and means become confused and there is little goal continuity over time; and "dissociation" - corresponding to Lawrence and Lorsch's (1967) version of the effects of lateral differentiation.

- 8 Dispersed systems matrix, product management, bipolar management, development projects and internal consulting services are the five models he identifies that represent increasing tendencies towards the task or project end of the continuum. Bipolar management is the model that corresponds to the traditional 'overlay' matrix model as defined by Knight.
- 9 Galbraith also notes the strategies of interdepartmental transfer (Kanno 1968, Newport 1969), and varying the composition of the team with respect to 'core' and 'peripheral' members (Marquis 1969), as more conscious mechanisms to minimise the effects of functional differentiation and lack of continuity and commitment respectively.
- 10 Galbraith distinguishes also between the design of an integrator role and the more formal system in which "managerial linking roles" are established. The former is based upon shared values and goals amongst task team participants; whereas the latter is suitable in circumstances where values and goals are not shared. The "managerial linking role" is vested with the authority to approve decisions, control budgets, etc.
- 11 These factors have been taken to be the appropriate criteria in the selection of the person to perform the role (Ziller, Stark and Pruden 1969).
- 12 For a most concise and extensive review and critique of theory and research into leadership in organisation, see Stogdill (1974).
- 13 It should also be noted that, coexisting with this interest in leadership processes in more structured settings, has been a continuing interest in patterns of informal and emergent leadership in more unstructured - usually laboratory - settings. This approach stems from the early work of Bales and colleagues (Bales 1950, Bales and Slater 1955), and finds more recent expression in studies undertaken by Limerick (1976a, 1976) among others. It also overlaps substantially with models of group processes based upon exchange theory (Homans 1958). Hollander and Julian's (1969) concept of the group leader's "idiosyncratic credit" in interaction for example, describes a developmental approach to leadership processes based upon exchange processes within the group; the general concern with "status" and status differentials within the group (eg Emerson 1962) marks out similar possibilities for the study of leader-member interaction. Due to the central concern with situational variables in this study, no specific attempt will be made to review this second stream of leadership theory and research. Other than to note, perhaps, the tendency for there to have been little attempt to try to integrate theory and findings from the two streams. Such a lack of overlap is manifested particularly in tendencies to have ignored or understated developmental aspects of leadership processes and the possibilities of emergent and informal leadership within formal organisations, in preference to concentrating upon the style or behaviour of individuals occupying de jure 'leadership' positions within the organisation (Bryman 1986).

- 14 For a review of the problems of operationalisation and measurement with respect to the reliability and validity of the measures used in current major competing models of leadership, see Fleishman and Kerr (1977).
- 15 See, for instance, Fiedler (1972, 1978), Fiedler and Chemers (1984), Foa, Mitchell and Fiedler (1971).
- 16 Here, for instance, a more developmental framework for the study of processes of leader-follower interaction may be of relevance.
- 17 The focus in this study is upon structural and behavioural characteristics. It should also be noted that a further set of norms are described in the design of information systems to complement the establishment of a matrix system. In particular, the design of a system that is specific to the 'technical level', which is focused upon problem-solving and decision-making needs, and which is established separate from the system established for control and evaluation purposes, is prescribed (see Hedburg 1975, Hopwood 1977 in Knight (1977)).
- 18 The approach is similar, and indeed related, to Burns and Stalkers' (1966) description of 'mechanistic pathologies'.
- 19 While beyond the scope of this thesis, it should be added that the other central contingent feature of Galbraith's scheme is the administrative cost of alternative design strategies.
- 20 It should be noted that Galbraith extends his model of organisational design to encompass the design of appropriate reward systems appropriate to such complex settings (op cit 1977). This topic is beyond the scope of this thesis. Other authors have also focused upon the design of reward systems in complex settings and implications for motivation and job satisfaction (eg Weiner 1970, Schein 1970, Tuite et al 1972).

CHAPTER TWO

MATRIX MANAGEMENT RESEARCH AND THEORY: SOME EMPIRICAL AND CONCEPTUAL QUESTIONS

The literature upon the structure and functioning of complex organisational forms has thus dealt extensively with a number of themes related to the peculiarity of these forms. Before turning to these issues in more detail, and relating them to characteristics of the network of intra- and inter-organisational relationships characteristic of construction project organisations, it will be useful to relate the themes that emerge from the literature concerning the rationale for matrix organisation and its various manifestations to the broader base of literature that has emerged in contingency studies of organisation. In doing so, attention will be first directed towards the framework adopted in matrix research and the empirical basis of the models which have been established. Later on in the chapter, attention is addressed to two main series of issues that, it is argued, have implications for many of the propositions noted in Chapter 1. Firstly the association between technology, size and structural attributes is investigated. Following this, attention is directed towards the potential implications of an inter-organisational matrix management system. It is this latter aspect which is then more fully developed in the later discussion in Chapter 4.

2.1 Research into Matrix and Project Organisations

The first point to be made concerns the highly prescriptive nature of much of the work in the field. The aim has commonly been

to assess the implications of task characteristics for the design of the organisation and to generate hypotheses concerning the appropriateness of design strategies given the circumstances faced. This approach, involving the establishment of normative propositions based upon observed phenomena and their effects in matrix-type settings, is useful in that it concentrates attention upon the range of 'problems' in implementation and operation that may occur and their correlates. Indeed, making such forms work effectively and cataloguing lists of problems that may occur has provided scope for a number of articles in addition to the works described above (eg Davis and Lawrence 1978, Argyris 1967, Hendry 1975, Perham 1970, Goggin 1974, Knight 1976).

In describing how to

implement a matrix structure, Gunz and Pearson (1977) conclude by saying:

"If this list (of steps to be taken) makes the process of designing and introducing a matrix organisation successfully sound complex, time-consuming and expensive, it will have accurately represented our views on the subject."

(ibid, p183)

There are two issues worthy of attention here concerning the empirical basis of many of the analyses undertaken. The first relates to the issue of performance. Knight (1976-7), for instance, has suggested that:

"Given the fact that there is as yet no agreed definition of what constitutes a matrix organisation, that several types of bilateral and multilateral structure have been and are being tried, and that these tend to be introduced in situations of operational complexity and change, the circumstances for systematic investigation (as distinct from advocacy from committed managers or social scientists) have hardly begun to exist."

(ibid, p120)

Little firm evidence has been presented to date. Such accounts that are given tend to discuss the form in terms of its 'advantages' or 'disadvantages' (eg Davis and Lawrence 1978, Goggin 1974, Hendry 1975) - rather than systematically investigate any association between the form adopted and company performance. This omission is perhaps not surprising given the widely-recognised problematic of measuring organisational performance in practice and the multiple and partially-conflicting criteria subsumed under the concept of organisational effectiveness.¹ What is of further significance about assessing the performance of organisations in which a dual orientation is the prime feature is the additional complexity introduced by virtue of this very feature. Knight (1977) has gone

further than most in discounting unitary and 'objective' measures of overall performance (eg profit, cost), in proposing a five-fold classification scheme for assessing performance which he labels the "criteria of structural effectiveness" (ibid, Chapter 9). These include levels of efficiency achieved; the ability of the firm to adapt to change over time; the level of control and accountability achieved; the level of co-ordination and integration achieved; and the 'social effectiveness' of the organisation - ie its ability to provide a context within which members' expectations and aspirations can be met. These recommendations by Knight certainly embrace what are generally regarded as the aims to be achieved through establishing a more complex structural form. However, presented as such they provide at best only a checklist of criteria to be aimed at (greater efficiency and better co-ordination, etc). The inter-relationships amongst these variables and, in particular, their constituent components and their inter-relationships (eg meeting deadlines and budgets, job satisfaction and stress) are not so clearly elucidated. Again this is perhaps not surprising given the complexity of the issue - and devising an adequate model to study these factors is well beyond the scope of the present study. However what is noticeable is the implicit tendency to discount what may be crucial contradictions in performance criteria. The approach tends to be one of prescribing an organisational solution contingent upon task environment and other internal conditions (eg the situation in the antecedent organisation) that will improve performance across the range of dimensions considered critical to the maintenance and development of the organisation. Problems in the operation of the firm with respect to these criteria are then taken to be aberrations and resolvable through the instigation of appropriate structural and

behavioural strategies that introduce 'checks and balances'.

While the contradictions inherent in a dual orientated form of organisation are given considerable attention, their bases in the contradictory tendencies in performance criteria adopted, and the impact that such goals have upon performance at the operational level (Perrow 1967) are given somewhat less attention.

A further and related quandary that pertains to the normative framework adopted in much of the analyses is that the highly contingent framework means that attempts to operationalise performance criteria - and not only the performance criteria themselves - must needs be organisation- or firm-specific, so lessening the basis for comparison between cases. This is so, since the variety of structural forms by definition emphasise orientations towards different needs in highly diverse sets of circumstances. This point suggests a tautology in efforts to comparatively evaluate the performance of firms acting in diverse environments: given that the most effective form of organisation in a specific set of conditions is that which most readily ensures the achievement of the set of objectives made salient in those conditions, then the effective structures that are devised reflect various mixes of performance criteria. For example, if the need to adapt to changing circumstances is marginally of greater importance to the firm than achieving high levels of internal efficiency in the use of resources then the criteria used to evaluate that firm's success should reflect these relative weightings. However, even given this adjustment, it is impossible then to compare performance with the performance of another firm where the criteria for success are given equal weightings. Because if this is so, then it must by definition

be because of the inter-relationship between task environment conditions and the internal structure of the organisation that in turn make the two firms completely different animals. In other words: one is not comparing like with like.

A more general point is that the approach commonly adopted not only emphasises inter-organisational differences from a normative perspective, but also often is based upon an action-centred organisational development strategy in which initiating change within the organisation is a predominant concern (eg Argyris 1971). As such, much of the literature concerning matrix and related dual forms of organisation is based exclusively upon an empirical bedrock of data obtained from individual organisation case study investigations, often in which programmes of structural change have been introduced. One implication of this is that there remain considerable difficulties in the comparative examination of matrix-type structures over a wide range of circumstances employing a standardised methodology. The models put forward by Galbraith and Knight in particular do lend themselves to the establishment of hypotheses that may be tested over a range of firms ranging in their tendencies towards 'pure' hierarchical or project forms. However, such an exercise has so far been lacking. The difficulties described by Knight in categorising the variants of the model as described in practice, reflects the peculiar difficulties of assimilating findings from research into a topic in which the history of research has made use of highly individualistic data gleaned from specific cases that have been identified in practice.

A second implication is that such cases have tended often to be those where the symptoms of matrix management have been highly visible,

and the structure more explicit (as with the NASA Apollo programme). Furthermore, they have oftentimes been cases in which some form of action research geared towards change from a more traditional bureaucratic structure to a matrix form has been the central intention (eg Argyris 1971). A consequence of this may have been that the 'net' that has been cast out to collect examples of matrix management in action may not have been cast very wide. Because of the focus upon large and highly visible instances (eg Apollo) and upon strategies of organisational development - both mainly with respect to firms operating in high technology fields - empirical attention has been directed towards those situations in which matrix organisation or one of its variants is most likely to (and should?) occur. In other words, the cases have tended to define the scope for investigation of matrix forms, rather than taking the concept of matrix management as a variable to be investigated across a range of different types of organisation involved in the design and construction of large, one-off, customised projects.

Such an approach is quite proper given the central concern in most of the literature with the strategic design options facing the firm as a consequence of complex and dynamic environmental conditions. It is particularly pertinent if an action frame of reference is being employed. However, the tendency to concentrate upon the strategic design options (and their implications for management) facing firms specialising in the manufacture of such types of product and operating in observably complex and changing market and technological conditions, provides perhaps only a partial view of the matrix phenomenon if one accepts the wider-ranging definitions supplied by Galbraith, Knight or Sayles, based as they are upon continua of relative orientations

and associated influence and authority patterns. Given the centrality of these criteria to a definition of matrix management, the question is to what extent are these tendencies identifiable in firms operating in similar product markets, but perhaps less "turbulent," environments. The preoccupation with technological conditions in particular may serve to obscure the relevance of matrix systems in more "low technology" settings. The converse to this argument, is that the occurrence of tendencies towards matrix management in more technologically-advanced fields may be overstated if there is no concurrent and parallel complexity and uncertainty in the structure and operation of output markets. The point, for example, about the electronics firms studied by Burns and Stalker (1966) was their comparative level of structuring of activities, and no evidence was given to suggest qualitative distinctions in the type of structure according to whether there existed multiple criteria for organising or not. The lack of such tendencies presumably reflects the greater homogeneity of product characteristics and specifications and the tendency for these products not to be produced in units or (very) small batches and custom-built for individual clients.

The general point to be made here is that, in the absence of more extensive and systematic enquiry into the matrix phenomenon on a comparative basis, it is difficult to know where to draw the dividing line between, and how to compare, the situations found and catalogued in which a fully-fledged matrix system of roles and relationships has either developed or been introduced, and those situations in which tendencies towards matrix management may occur either formally or informally: not necessarily being widespread, but nevertheless significant for the operation of the organisation and

for the position of groups within it. The argument being pursued in this study is that the construction industry - by no means a high technology environment, but a project-based industry - is one in which matrix management is of particular relevance and interest.

2.2 Technology, Size and Structure

The second main series of issues to be addressed in this chapter concern the inter-relationships between size, technology and structural variables. Namely, the models of matrix management observed or proposed focus their main attention upon direct-workflow related activities of the organisation: specifically the production process and also product design and process engineering. The common focus is upon the decision-making task team group operating at the 'technical' level within the organisation. The observation of a more decentralised, organic structure in this respect is consistent with more broadly-based findings that relate the occurrence of less routine task work with greater organisational complexity and the tendency towards 'organic' features being exhibited at operational levels. However, such findings have coexisted with considerable ambivalence concerning the association between characteristics and implications of the production system employed and the structure of the organisation as a whole when extended beyond the immediate focus upon the production process and task team group.

2.2.1 Technology and Structure

Woodward's (1958, 1965) early research focused in part upon firms employing unit and small batch production systems.² She found that such firms exhibited fewer levels of authority and lower supervisory/labour ratios than firms employing the two other types of production system; and that such firms were characterised (as were those with continual process production) by lower spans of control at senior levels, less specialisation in management functions, and greater informality and flexibility in management procedures than those undertaking large batch and mass production operations. Her

results, however, were limited by their specific focus upon the type of production system employed. While, for instance, supervisory staff/labour ratios on the production line may indeed be systematically related to the type of system employed, it is not at all clear how such a pattern may be repeated - either at higher levels within the firm, or within departments not directly involved in managing the production workflow - such as sales, accounts, personnel and R & D (Hickson^{et al} 1971, Pugh 1973). Nevertheless a more broadly-based interpretation of the meaning of technology - incorporating not only 'operations technology', but also 'materials technology' and the 'knowledge' and expertise required to perform work (Hickson et al 1969) - has lent more weight to the technology-structure association. Employing Perrow's (1967) framework, Hage and Aiken (1969) for instance found that a relationship existed between the degree of work routineness and structural attributes. Hall (1962) found differences among subunits of organisations in their structural attributes and was able to relate these to technological differences: he observed that 'knowledge technology' employed in administrative work is as important an influence upon departmental attributes as the 'operations technology' is upon the attributes of production departments. (Parallel findings in complex environments have been noted already.)

However, later developments to the contingency model that have extended it to a wider range of possible predictor variables than technology per se, have tended to show the lack of any clearly discernible and consistent relationship. The research programme begun at Aston in the 1960's serves as the most prominent example (eg Hickson et al 1969, Pugh et al 1969a and b, Hickson et al 1971, Child 1973).³ The aims of the research programme were more macroscopic than the

interests pursued here and deserve brief mention. The programme was concerned with investigating the relationship between various aspects of the organisation's context (its technology, size, origin and history, charter, location, patterns of ownership and 'dependence') and its structural attributes. Using a multivariate approach, the latter were operationalised according to five main dimensions: levels of role specialisation; standardisation of rules and procedures; formalisation; centralisation of authority; and configuration (the 'shape' of the organisation in terms of the chain of command, spans of control and proportion of support personnel).⁴ From the results a typology of bureaucratic forms was constructed on the basis of four principal component factors: the structuring of activities (related to specialisation and standardisation); the concentration of authority; the line control of workflow activities (whether direct and personal or impersonal); and the size of the supportive component. The first two of these have been taken to be the two primary components in the categorisation of organisational types. Thus, for instance, "personnel bureaucracies" and "implicitly-structured organisations" have less structured activities and dispersed patterns of authority (eg Pugh et al 1969b). As a framework for the description and classification of organisations according to their structural attributes, the Aston scheme is of some considerable importance. However, attempts to relate these to contextual variables (other than size and 'dependence') have been less successful. Technology, measured according to the degree of "workflow integration" observed, has been shown to be of limited importance as a predictor variable (eg Pugh 1973). Based on a rework of the Aston data, Aldrich (1972) has suggested the reinstatement of technology as the most important contingency factor; while Child and Mansfield (1972) have

observed that the results with respect to technology are improved once administrative and service units are excluded from the sample. However the results are at best inconclusive and, at worst, dismissive of the impact of technology as so conceived upon structural characteristics of the organisation as a whole.⁵

2.2.2 Production Tasks and the Wider Organisation

Relating these findings back to the literature on matrix management in complex and uncertain environments, the point is not that such findings negate the propositions made concerning the association between task characteristics and structural attributes. The Aston research, for instance, tests propositions based upon a deterministic model of the association between context and structure for effective performance; whereas the matrix literature adopts a normative framework for assessing strategic design options. Indeed, the variable of "strategic choice" (Child 1972), has been taken to constitute the critical intervening variable in any presumed direct association between technology and structure. Child (1972) argues that theoretical models derived from statistically established patterns of association between contextual and organisational variables attempt to explain the organisation at one remove by ignoring the essentially political process whereby power-holders within the organisation decide upon courses of strategic action (including not only the choice of design options, but also environmental manipulation (Thompson 1967), and the establishment of operative goals (Perrow 1961)):

"The critical link lies in the decision-makers' evaluation of the organisation's position in the environmental areas they regard as important and in the action they may consequently take about its internal structure ... Any association between the two may be more accurately viewed as a derivative of decisions made by those in control of the organisation

regarding the tasks to be carried out in relation to the resources available to perform them. Indeed this may render any association between technology and structure quite tenuous."

(Child 1972, pp 5-6)

It is precisely these processes which students of matrix organisation tend to be interested in, in terms of establishing the range of design options available given the prevailing set of environmental, or contextual, circumstances.

The point to be made concerning the association between technology and structure is rather that the focus in the matrix literature upon the structure and functioning of the task team group and its (and others') relationship to the wider organisation, has precluded a fuller examination of general features of the organisation as a whole. There is no clear impression given, for instance, of the structural attributes and operational characteristics of those sections or departments providing support services to the main 'line' organisation, and how these may be influenced by specific characteristics of the task environment they also face. One might hypothesise, for example, that there would be differences between sales and accounts sections in their tendencies towards a more 'organic' system of working. Qualitative differences in the commercial environment may imply differential modi operandi. The literature on matrix and project organisation and management does not restrict its interest to the production technology employed (task variability and complexity being the key variables). Indeed, 'knowledge technology' and its centrality to the study of structures and processes of interaction in complex settings (Perrow 1967, Hickson et al 1969, Dewar and Hage 1978), is taken as the crucial factor.⁶ It does however tend to restrict its interest to mainstream production task activities - thereby serving to narrow somewhat the predictive capacity of the models employed.

A related point is that no firm impression is given of the relative degrees of 'coupling' (Weick 1976) between organisational activities and implications for the management of the organisation as a whole. For instance, the extent to which the task team group operates in a relatively self-contained fashion from other task team groups within the organisation. This is particularly so with respect to relationships with groups or sections which are not involved directly in the management of the production workflow, but in sequentially-related activities: particularly those involved in input procurement and output distribution activities (eg materials and plant procurement and handling; product storage and distribution). It may be that the production techniques employed and associated patterns of resource use are either fully project-specific; or that they are shared between task groups, in which case some mechanism for scheduling production capacity and resource usage on an inter-group basis will be necessary. Similarly, in the case of output distribution, in which either a 'parallel' or 'pooled' system may operate.

Two further and related points also concern the notion of the degree of coupling of activities. The first concerns the relationship between the task team group and management at higher levels within the organisational hierarchy. While the tendencies in the matrix literature towards decentralisation and extensive participation by 'technical' level participants in the management process are clear, the implications of a 'fusion' of levels (Kingdon 1973) for higher-level management are not as clear. In the first place the question needs to be raised of the extent to which there is such a 'fusion' and its comparative implications across different types of situation in terms of the relative locus of decision-making activity. Secondly, and more specifically, does such a 'fusion' imply a greater level of

involvement by higher level management in terms of the technical content of discretionary decision-making activity; or is there some way in which their respective roles across organisational levels are more clearly delineated? Recent descriptions of matrix organisation and related forms of 'ad hococracy' (cf Mintzberg 1979) have tended to describe them as relatively 'flat' structures - with comparatively few levels between task group and departmental manager level - and narrow spans of control.⁷ However a fuller discussion of both the range of variation in intervening levels and their general configuration or shape and patternings of roles and relationships within the wider matrix configuration is largely absent from the literature. The general point to be made here is to ask the question of to what extent and in what way do the 'system requirements' of a complex production task penetrate into higher organisational levels.

The second point concerns the tendencies to subsume all roles and relationships within the organisation under the matrix rubric. The possibility that single or dual criteria for the design of the organisation may occur at a variety of levels is given little attention in preference to the adoption of an all-embracing matrix framework for the work of the organisation as a whole. Again the variants described by Knight (1977) provide a number of instances of relatively self-contained matrix-type structures occurring within an organisation within which other design criteria are adopted at various levels. The more limited versions of matrix management (especially task forces) similarly point to the possibilities of effectively decoupling tasks which require some form of matrix management from mainstream organisational activities based upon a

classic product, process or place formula for specialisation.

The general comment to be made concerning this and the earlier points, is that the full complexities of those organisations being investigated is rarely fully explored, other than to provide a relatively unclear backdrop to the existence of matrix management in some form identified at the operational level, involving some, but by no means necessarily all, of the organisation's production activities. There is an evident irony here, in that organisational complexity and idiosyncratic variation are taken to be the cause célèbre of the student of matrix organisation. But it has been taking the task group as the starting point for investigation that has led to this imbalance. Again the tendency to have focused attention on a specific class or narrow band of organisations exhibiting matrix features, and usually those operating in high technology fields - and then to have focused almost exclusively upon these features - may have served to obscure important comparisons and contrasts in the phenomenon of matrix organisation and management.

2.2.3 Group and Organisational Size

The second significant omission from the study of matrix-type structures has been in not fully exploring the effects of group and organisational size. Galbraith, for instance, acknowledges in passing the importance of size variables in contingency approaches to the study of organisation (1973, p7, note 8), but fails to incorporate the variable and assess its potential implications. The most clearcut and consistent finding from the Aston research has been the high positive association found between organisational size and structural complexity (ie greater specialisation, standardisation and formalisation and decentralised authority: eg Pugh et al 1969b).

Size was found to be by far the largest single predictor variable of organisational characteristics. Such a result has been complemented by findings from other programmes. Blau's research - mainly into state agencies, universities and department stores (Blau et al 1966, Blau and Schoenherr 1970, 1971, Blau and Scott 1962) - uncovered a positive association between organisational size and "differentiation" subject to the economies of scale in administrative overhead available to larger firms ("differentiation" was measured according to the number of levels, departments and job titles). The tendency for both programmes of research to rely heavily upon formal documentation and descriptions of what Brown (1966) terms the 'manifest' structure - rather than relying upon perceptual accounts of the actual workings of the organisation (eg Hage and Aiken 1967a, 1967b) has not gone unnoticed. It has been noted that the results obtained differ when use is made of perceptual measures as opposed to official documentation (Hall and Tittle 1966, Pennings 1973).⁸ Moreover, other findings have pointed to inconsistencies in the size-structure association (eg Hall et al 1967b, Aldrich 1972). Nevertheless, size occupies a position of potentially critical importance as a contextual factor in contingency approaches (Hage 1980, Hall 1982).

A number of studies have noted that size and technology may be co-predictors of structural attributes. Blau and McKinley (1979), in a study of architectural firms, found that whether those performing uniform tasks exhibited greater structural complexity and task diversity than those performing non-uniform tasks was dependent upon their size; whereas for the latter it was dependent upon the level of professionalisation. Dewar and Hage (1978) found that size was associated with the development of administrative specialities, whereas greater technical diversity was associated with more role specialisation. Similarly Daft and Bradshaw

(1980) in their study of administrative and academic departments in universities. Of more direct relevance to this discussion are sets of findings which have addressed the impact of size as a moderating variable. In general, increased size is seen to pose problems through creating a tension in the pressure to decentralise decision-making activity while at the same time maintaining centralised control over decisions made at lower levels in the organisation. Part of the response may lie in the tendency for procedures to be more standardised and formalised through the establishment of rules which allow decisions to be more programmed (Mansfield 1973). Such a possibility may help explain the Aston researchers' finding of a weak negative association between bureaucratic complexity ('structuring of activities') and centralised authority (ie greater size means a more decentralised authority structure and a concomitant reliance upon bureaucratic mechanisms of control through formalisation and standardisation). Similarly, Blau (1970) in a study of public personnel agencies found agencies with highly formalised procedures to have a more decentralised structure of authority. However, in more complex and uncertain task environments one would expect the onus to be put more heavily upon less obtrusive controls (March and Simon 1958, Simon 1960). Certainly, considerable emphasis has been put upon the role of professionals in reconciling the tendencies towards decentralisation with efforts to retain control in larger-scale organisations in which the nature of the task places a premium upon decentralised decision-making activity (Blau and Schoenherr 1971, Hage 1980). Such findings are added to by others which address more directly the moderating impact of size upon the technology-structure association. Van de Ven et al (1976), for instance, found that while task uncertainty and interdependence placed

a premium upon more lateral, rather than vertical, interaction and the use of more personal co-ordination mechanisms respectively, increasing size tended to lead to the adoption of more structured and impersonal forms of co-ordination. Similarly, in their elaboration of the 'organic-mechanistic' model, Hull and Hage (1982) found that increasing size constrained the organisation's ability to operate a more flexible, organic form of organisation in order to achieve high rates of technological innovation.

Such findings certainly lend consistency to the common view of a small, 'organic' task team group operating in conditions of task complexity, uncertainty and interdependence. However, the problem arises because it is precisely the small organic group that is taken as the starting point for the analysis of matrix-type organisations. The findings reported above beg the question of what affect group size may have upon the mechanisms of co-ordination and patterns of interaction within the task team group in a matrix setting. For instance, assuming a matrix form is requisite, if the nature of the task requires some input from a large number and wide range of project personnel (meaning a large group), do the propositions made concerning the (appropriate) form, level and scope of interaction needed still hold. If this possibility was not applicable (ie task team groups are always small in scale), then there would be no problem in extrapolating the findings from studies of matrix management to other situations. Unfortunately, the limited scope of matrix research coupled with the tendency to assume small scale group operations mean that this may not necessarily be the case. It is a priori quite possible to conceive of a situation in which the task team group required to operate in a matrix structure is large in itself. Moreover, following the proposition

that the boundary of the group will change as circumstances do and extend to those with information and expertise relevant to decisional processes at various points in time, it is also quite possible to conceive of significant variation in taskgroup size over time. Furthermore, if the earlier suggestions that closely-coupled working relationships with operational groups working in parallel, and with sequentially-linked and vertically-linked groups were extensive, then the possibility of size becoming a relevant variable is further enhanced. If any of these factors were relevant, then one might expect the association between task and organisational characteristics at the workgroup level to be moderated in some way by the effect of group size, and for size to become a potentially significant source of variation across cases.⁹

A second size-related issue to be briefly noted relates back to the earlier comments made concerning organisational subgroups operating beyond the confines of the focal task group(s), and concerns the effect of the size of the organisation as a whole. Specifically, it is to ask the question of to what extent the total scale of operations of the organisation may influence the applicability of concepts central to an understanding of the operation of a matrix system? For instance, may 'pooled' systems of input and output resources and facilities shared amongst task team groups be more effectively administered in a larger organisation via more routine, bureaucratic mechanisms of co-ordination and control. More generally, in a large organisation may the need to exercise control over decentralised decision-making activity in a large number of task team groups make for a greater reliance upon more 'obtrusive' mechanisms than is found in a smaller organisation operating a matrix system. It has

been argued here that such issues are worthy of considerably more attention than they tend to receive in the literature to date on matrix and project management forms of organisation.

With a few notable exceptions (eg Sayles and Chandler 1971), recent models of project and matrix forms of organisation and processes of management have concentrated attention for the most part upon the strategic design options facing the organisation engaged in undertaking series of one-off, customised projects. As such, the organisation, as opposed to the project, has been taken as the central focus and therefore unit of analysis. The concern has been to elucidate the nature of the relationship between the wider organisation and its operational unit operating in a more complex and uncertain task environment. As stated earlier, the focus of this study is upon the structure and processes of interaction within the project organisation established for the management of construction work on site. As such, attention is largely directed towards the network of interaction amongst personnel from the range of organisations within the "temporary multiorganisation" (Cherns and Bryant 1984) or "confederal system" (Sayles and Chandler 1971) or "cluster" of organisations (Kingdon 1973) that is established to undertake a construction project, bearing in mind the network of relationships between these organisations at a broader level. Before turning in more detail to discuss the nature and form of interorganisational relationships in the co-management of project task work, it is useful first to address the location of this dimension in models and studies of project and matrix management. The argument that is developed here is that the almost exclusive attention paid to the individual firm as the focal unit of analysis in the matrix and project management literature has tended to obscure consideration of the impact of relationships with external

agencies upon the form and process of management within the organisation.

There are two closely-related issues that arise here. The first relates to the question of the potential impact of external relationships upon the internal structure and functioning of the organisation in which some form of matrix management occurs. A clear example of the issue is found in the work of Kingdon (1973). His interpretation of the development of matrix organisation in the Apollo setting is predicated upon the need for the firm to retain its autonomy while establishing a framework for close collaborative working relationships with the client (see above, p1.2). However, the implications of this situation for the performance of work at the operational level are given little direct attention, in preference to concentrating upon the characteristics of the firm's internal structures and processes contingent upon technical characteristics of the task (eg the relationship between programmers and systems analysts). To the extent that 'boundary management' becomes a more pervasive phenomenon in such conditions, and also to the extent that technical and managerial levels are "fused" (ibid), then one would expect external relations to be included much more fully as a set of contextual factors that may influence internal forms and processes of management. The potential implications of extensive patterns of interorganisational interaction at the managerial /technical level receive comparatively little attention in the work of Kingdon (1973) and others interested in the form of organisation observed. This is not to suggest that all such instances necessitate taking this dimension into account; nor that it is necessarily of significance (it is quite possible a priori to conceive of

situations in which a matrix organisation, for example, is self-contained and relatively little, if any, accommodation or interaction is required across organisational boundaries). Rather it is to suggest that those instances in which such forms have been investigated have tended to be those in which the degree of inter-organisational interaction and collaboration has been observably high. The point suggests an irony: it is surprising to find that a type of situation which is essentially defined by an orientation towards project objectives articulated by an external body (ie the client) - and necessitating close working relationships with that body - is discussed and analysed with comparatively little attention paid towards the potential import of that central dimension. It is more so given the contingency framework adopted and the emphasis placed upon the 'open system' characteristics (Emery and Trist 1965) of the organisation.

The second issue relates to the tendency in the literature to obscure intra- and inter-organisational distinctions in the roles and relationships found within a matrix context. It is related to the first issue in that it perhaps helps to explain the lack of attention paid towards the impact of external relationships. Specifically, the tendency is not to differentiate clearly between internal and external processes of interaction within a project setting, and consequently to more or less equate the characteristics of internal and external patterns of coordination and control. As an example, Sayles' (1976) description of matrix management appears largely to be concerned with describing conditions within a single organisation:

"(a matrix) introduces structural imperatives that serve to maintain fluidity in the balance of power among major subdivisions of the organisation or system and discourage the formation of rigid, exclusionary norms and sub-optional, vested-interest goals."

(ibid, p17; emphasis added)

However it is quite clear from his earlier discussion of the role of integrator that the inclusion of the phrase "or system" is meant to denote the wider applicability of the ideas to a matrix system of roles and relationships in an inter-organisational context:

"(the integrator) is usually not in a position to make the relevant decisions himself because critical elements are controlled by autonomous organisations reluctant to make the required decisions themselves."

(ibid, p 10; emphasis added)

In this account, interdepartmental relationships among functional managers have somehow become transferred into interorganisational relationships among respective agents. If the role of integrator is one of "boundary dweller" (Wilemon and Gemmill 1971), then it is left unclear as to whether the 'boundary' under discussion is that between different sections, departments or divisions within the same firm; or between different organisations involved in the same interorganisational 'project system'. Despite more precise formulations that focus specifically upon the organisation as the unit of analysis (eg Galbraith op cit, Knight op cit), the ease with which matrix-related concepts tend to be treated as comparable whether applied to an internal or external set of relationships is disconcerting given the fundamental difference in the basis of the relationship that underscores interaction in each case. In the

former, structural relationships of authority and accountability link respective groupings; in the latter case, transactional relationships are the salient feature. Different mechanisms of control correspond to these differing forms of relationship since they equate with differing bases of motivation: hierarchically-based on the one hand; market-based on the other (Williamson 1975, Ouchi 1980). Yet the tendency to equate the two, or worse, to be unclear as to which forms of relationship are the focus of study, is quite common in the matrix and project management literature.

It is argued here that both sets of issues have important implications for understanding the processes at work within such complex forms of organisation - both internally or indeed externally within a wider inter-organisational matrix system of roles and relationships. Each of these issues will be addressed in turn before turning to an analysis of conditions in the construction industry in Chapter 3. Chapter 4 will then return to a more detailed examination of the correlates of interactive behaviour within a multi-organisational project setting.

Organisational research which has sought to address the association between the organisation's environment and internal structures and processes has come to recognise the more direct potential impact of environmental conditions upon internal structures and processes via the boundary-spanning component(s) of the organisation. The limitations of a deterministic model of organisational functioning in allowing for the prediction of any significant direct association between environmental context and the structural characteristics of organisations as a whole has been noted (Child 1972). Nevertheless there is good reason to expect more direct and significant associations when the boundaries of the organisation are taken as the focal areas of investigation - reflecting a degree of "permeability" at the boundaries of the organisation (Parsons 1960, Blau and Schoenherr 1971, Kochan 1975). Such a possibility has been suggested in critiques of the Aston programme of research (Mindlin and Aldrich 1975). Thompson's (1967) model specifically focuses upon boundary conditions as central to an understanding of the relationship between environmental context and structural form: He suggests that, the greater the number of constraints and contingencies that arise, then the greater the need for the organisation's boundary-spanning component to be segmented or divided up into specialised parts, and hence the greater the total impact upon the firm's organisational structure (ibid, ch. 6).

This would suggest that it would tend to be those organisational units operating at the boundaries of the organisation (eg sales,

purchasing, distribution, research and development) that would prove most susceptible to environmental influences. In Thompson's scheme, it would be those functions that "buffer" or "mediate" the technical "core" within organisations, and which perform a central role in coping with high levels of task uncertainty, that would be most affected.

Such a possibility is lent consistency by a good many research findings. In a study of joint programme management in health and welfare agencies, for instance, it was found that no association existed between the degree of interdependence and the level of overall formalisation (and only a low association with the degree of overall centralisation); however greater inter-dependence was found to be associated with greater structural complexity, in terms of the professionalisation of the workforce and the proliferation of co-ordinating and communication mechanisms (Aiken and Hage 1968). Lawrence and Lorsch's (1967) study of firms in the container, food and plastics industries did detect differences between the internal characteristics of research, sales and production departments - both with respect to each other and across the industries - that were linked to differences in environmental uncertainty. At the same time, however, the findings are by no means unequivocal. Liefer and Huber (1977), for example, found that organisational structure had a greater effect upon behaviour in boundary-spanning units than the nature of the perceived environment, according to the frequency of dealings with individuals and groups. Consequently a good deal of caution needs to be exercised in expressing too overly deterministic a view of the relationship between context and boundary unit structure and

processes. It is not the intention here to delve further into an explanation of the nature and extent of a possible association between characteristics of the boundary unit(s) of the organisation and environmental conditions.¹⁰ The point to be made here is simply that the link between environment and the internal workings of the organisation would appear to be potentially most apparent in the performance of managerial work as it relates to those functions undertaken at the boundary of the organisation.

The point about project systems is two-fold: firstly, that the 'technical core' functions undertaken by the focal organisation themselves span the boundary of the organisation to the extent that they involve reciprocally-interdependent working relationships between individuals and groups from a variety of organisations involved in various ways in the specification, design, resourcing, manufacture and inspection of component products. Secondly, and following on from this, that interorganisational, or across-boundary working relationships during taskwork form a critical axis in the definition of the organisation's relationship with its immediate task environment. It is not simply that constraints and contingencies arise due to the technical nature of the task being performed by the focal organisation, but also that these constraints and contingencies may be articulated by agents or agencies external to the focal organisation: through the specification of targets, methods or materials; or changes in these specifications as the task is performed, for example. Project tasks will tend to be performed on the basis of targets, specifications and schedules of work to some extent set by external (ie client) bodies. In construction, as in other types of project setting, client representatives may then

play a central part in establishing detailed plans (the design for the works) and inspecting, maintaining and controlling the work as it is produced. Further, to the extent that the focal production organisation (in the case of construction, the main contractor) subcontracts the supply, manufacture and installation of components of the total product, then the process of interorganisational interaction in the planning, organising, co-ordination and control of taskwork is repeated at a different level for the range and variety of 'packages' of work that form constituent parts of the total production, or construction, process. The 'project team' in these instances comprises staff from a variety of organisations, performing different functions at different levels, and involved at various points and in a variety of ways in the total design and construction project cycle. In other words, one has to take into account the performance of complementary functions for the realisation of the common task objective and its manifestation in a 'work relationship pattern' (Herbst 1974) that crosses the boundary between organisations.

The question then becomes one of: to what extent and in what ways do external working relationships influence the internal structure and operations of the firm involved in a project setting? Or, more particularly, the workings of the 'organic' task team structure that is expected to be appropriate in such circumstances. One possibility that clearly contrasts with the emphasis in the literature on matrix and project settings is that the "business system" relationship (Sayles and Chandler 1971) between organisations puts a premium upon a more, rather than less, structured approach to the management of project work. The need to meet contractual

deadlines, budgets and standards, the legal implications of decisions reached and so on, may engender a rather more cautious than creative approach to managing work in an uncertain task environment. Sayles and Chandlers' (1971) findings, returned to below, have addressed this possibility in the context of relationships between organisations, and have pointed to the types of rigidities that may emerge in interaction. The question here is whether such conditions have any impact upon the internal conditions within the individual firm engaged in this type of setting. The implications for the focal organisation in the longer term may in fact be a more structured form of organisation in which documentation is more formalised, decisions are taken more centrally and administrative and managerial procedures are purposively routinised. Such a possibility is given credence if one looks at findings from other research. For instance, it has been noted that organisations operating in more hostile or competitive environments may tend to 'tighten up' their operational and administrative procedures (Khandwalla 1972, Pfeffer and Leblebici 1973). One might speculatively link this type of environment with that facing the organisation which has to competitively tender for one-off contracts with client organisations who are concerned with driving a hard contractual bargain (Sayles and Chandler 1971). The question is very much an open one, since the tendency in the literature is not to address fully the potential impact of such conditions. The general point is that, in the absence of a more complete incorporation of variables related to external relationships in models of project organisation, one can only speculate upon the possibility that at least some of those 'aberrations' to the norms prescribed by researchers into matrix and project management may be accounted for by the nature

of processes of interaction with bodies external to the focal organisation.

The lack of full consideration given to the potential impact of external relations is quite surprising given the centrality of Thompson's (1967) framework for categorising the co-operative strategies adopted by firms in uncertain task environments in general descriptions of the role performed by the focal organisation within the wider project system (eg Kingdon 1973). Thompson identifies three strategies which he labels as "contracting", "co-opting" and "coalescing", and which he relates to the organisation's attempts to secure power - in the sense of reducing uncertainty - to offset their dependency upon the environment (ibid, p34). He describes the use of a particular strategy according to the relationship between organisational needs and 'support capacity'. More pertinent to this discussion, he notes that while these three forms of co-operative strategy increasingly help to cope with greater levels of task uncertainty, they also increasingly represent greater levels of organisational commitment and accommodation to external agencies:

"Under co-operative strategies, the effective achievement of power rests on the exchange of commitment, the reduction of potential uncertainty for both parties. But commitments are obtained by giving commitments, and uncertainty reduced for the organisation through reduction of uncertainty for others. Commitment thus is a double-edged sword ..."

(ibid, p35)

It may be the case that external relationships are based, say, upon exchange agreements for the supply of basic raw materials at an

agreed price. The relationship is one of direct economic transaction and, as such, may require relatively little accommodation on the part of each agency. On the other hand, it may be based upon a joint commitment to achieve a specific objective or set of objectives, in which case a greater degree of mutual accommodation may be required, since the task crosses the boundary between organisations. Thompson points to the establishment of consortia for major construction projects (Miller and Rice 1959), and multi-disciplinary approaches to custodial treatment in health care institutions (Perrow 1965) as examples of the more constraining latter alternative where more tightly-coupled working relationships between organisations occur and where, in particular, decisions may be reached jointly. Referring specifically to the construction industry he notes that:

"In the construction industry ... the contractor and the customer establish a relationship which has the effect of placing the customer in the project's administrative apparatus; and if the customer is an organisation rather than an individual, the customer's agent may be a full-time liaison member of the project."

(Thompson 1967, p44)

It is precisely this type of quasi-administrative arrangement which, it is argued, is salient to the conditions faced by the organisation involved in the types of project settings taken as those appropriate to the study of matrix management. Thompson (1967) notes in particular the constraining influence of a commitment to joint decision-making:

"A coalition may be unstable, or have a stated terminal

point. But to the extent that it is operative, the organisations involved act as one with regard to certain operational goals. Coalition not only provides a basis for exchange but also requires a commitment to future joint decision-making."

(ibid, p36)

A similar tendency towards a more "unitary" context for decision-making is identified by Warren (1967, 1972):

"Insofar as (organisations) concert their decisions voluntarily, they may enter into a coalition, under which they retain their autonomy but make decisions and act in concert only insofar as they see such behaviour as preserving or enhancing their respective domains."

(Warren 1972, pp24-25)

Similarly, the centrality of a commitment to joint decision-making in project systems is recognised by Sayles and Chandler (1971):

"... (planning) is a dynamic process by which both inside and outside interests arrive at a new balance of power - reflected in new structure and new policy - designed to establish the parameters of executive decision-making for some period of years but not forever."

(ibid, p42)

In other words the agreement is based upon the commitment to joint achievement of a common goal, giving rise to joint shares in the resultant outputs and benefits. Unitary behaviour becomes requisite if task accomplishment is to be effective and mutual gains from that realised. The next section turns in more detail to the implications for patterns and processes of interaction. The point to be made

here is that the implications of such more tightly-coupled working relationships with external agencies for internal structures and processes tend to be largely ignored in the relevant project and matrix management literature.

2.5 External Relationships in a Project Management Setting

2.5.1 Introduction

The previous section addressed the possibility of a more profound impact of external relations upon the internal workings of the firm than is commonly assumed in the matrix and project management literature. The aim of this section is to address the second point raised: namely, the implications of the tendency to obscure intra- and inter-organisational differences in the joint management of project work. As a first step, the discussion will turn to the broader relationship between the organisations involved, before assessing the implications of patterns of goal- and resource-dependency for the processes of interaction at a more disaggregated (ie operational) level of analysis. It should be noted that thus far the discussion has tended to focus upon the individual organisation rather than upon the network of relationships within the wider 'project organisation or system'. This section heralds a move somewhat towards the latter perspective. Indeed, the independent variables of the foregoing discussion (the external relationships with other bodies) are brought more towards the centre stage, and later treated as the set of dependent variables central to this study (ie the structures and processes of interaction between autonomous organisations). Employing this framework, interest turns to the impact of, among other things, internal characteristics of the one organisation for patterns of external interaction with other organisations with which it is linked in the management of project work.

In pursuing the line of argument in this section, two simplifying assumptions are made which will be returned to in more

detail at a later point. Firstly, use is made of a simple dyadic system of roles and relationships in which two organisations (say client and contractor) performing complementary functions (ie design and construction) are linked together in a (contractual) relationship to achieve a common objective (ie the construction of a new building). Later on, some of the implications of a more complex (triadic) system will be addressed (in the construction setting the client-designer-contractor and designer-contractor-supplier relationships in particular). Secondly, the assumption is made of consistency between wider organisational and operational subunit goals with respect to external interaction. Later on in the discussion, some added complexities of hypothesising differences in goals between the relevant parts of the organisation will be returned to. This will correspond in part to the emphasis placed by Kingdon (1973) on forms of "segregation" and, more generally, to the wider concern with the control of decision-making within the organisation in conditions characterised by high levels of task uncertainty and interdependence (Galbraith, op cit). However, for the moment and for purposes of exposition, the assumption of goal consistency is maintained.

2.5.2 Interorganisational Relationships

The series of points to be made here pertain to the inter-organisational network of roles and relationships and the association between organisational goals and project objectives. Each organisation can be conceived of as part of an inter-organisational "network" (Jacobs 1974 , Pennings 1976) upon which it is dependent, to a greater or lesser extent, for performing the functions which it undertakes in order to achieve the specific goals which it intends to pursue (Levine and White 1960).¹¹ A similar,

but distinct, construct is that of the "organisation set" (Evan 1966). Both constructs allow for a focus (in an industrial setting) upon relationships with (a) customers, distributors and users of the product or service; (b) materials, equipment and component suppliers; and (c) other bodies such as statutory agencies, unions and employers' organisations, etc. The difference is that while the latter takes relationships from the viewpoint of the individual organisation as the focus of investigation, the former takes the aggregated patterning of roles and relationships - the network itself - as the appropriate unit of analysis.

Interorganisational theorists and researchers have long identified the centrality of the relationship between organisations' goals as the primary defining characteristic of an exchange relationship. In their study of community social health and welfare agencies, for instance, Levine and White (1960) noted:

"Organisational exchange is any voluntary activity between two organisations which has consequences, actual or anticipated, for the realisation of their respective goals or objectives."

(ibid, p121)¹²

Conversely, in order to achieve their goals, organisations are dependent to some degree upon the resources and actions of other organisations whose performance contributes in some way toward the realisation of the organisation's goals: whether that contribution is manifested in an exchange of resources on agreed terms, or in a more extensive agreement that commits both parties to the pursuit of a common task objective.

Central to the study of interorganisational relations have been the implications of patterns of goal dependency, their manifestation in the resources brought by each party to the relationship (Yuchtman and Seashore 1967), and consequently the relative 'power' of one party vis-a-vis the other. Aiken and Alford (1970), for example, suggested that the community systems they studied could be viewed as networks of interorganisational fields, in which the basic interacting units are, in effect, centres of power.

Thompson's (1967) exposition of co-operative strategies, based upon Emerson's (1962) model of power-dependency relations,¹³ is concerned chiefly with the options available to the organisation given some degree of dependency upon external organisations which control resources necessary for the achievement of the focal organisation's goals. One implication noted of greater interdependence has been the tendency for the organisation's strategic objectives to be formulated in terms of a selection of goal paths that offer maximum convergence with the interests of other parties represented in the "organisational matrix" (Selznick 1949, Thompson 1967). The main general point to stress, however, is the centrality of patterns of goal dependency and power, in relation to the locus of control over resources necessary to achieve those goals, in relationships within an inter-organisational setting.

In a project setting, the wider goals of each organisation are linked through the pursuit of a common (and agreed or negotiated) set of project objectives - namely the construction of a building to

specific time, cost and quality parameters. These constitute the focus for the "action set" within the broader interorganisational network (Aldrich 1979, pp280-281). A precise formulation of the concept of goals, and the relationship between goals and means is a difficult exercise (Simon 1964), and one that is beyond the scope of this study. However, it is possible to assert that in an interorganisational setting such as that under study here, the set of project objectives that link the autonomous organisations are, for each organisation, subordinate to that organisation's wider goals. For both organisations it is almost impossible to conceive (although it may occur in very rare instances) of the construction of a building as being the ultimate aim in itself. For the client it is more likely to be part of a longer-term programme of development, geared towards future growth and/or profitability. For the contractor, similar concerns (eg sales growth, profit) will be critical in the 'location' of the individual project in the firm's wider mainstream activities. Beyond this it is possible to conceive of complex vectors of goals and objectives. For instance, the project may constitute part of a market penetration strategy. If so, there arise questions of how this relates to other strategic objectives pursued by the firm. (A different point that relates back to the earlier assumption made of goal consistency, and one that will be returned to below, is that it may represent differing goals pursued by different sections or divisions within the same organisation.) However, in all cases the common set of project objectives will constitute part of the means towards achieving wider organisational goals. For the organisations taken together, the set of project objectives can be conceived of in a manner not dissimilar to that of "operational goals" (Perrow 1961) - albeit in an interorganisational context.

The general point here, with respect to any specific project and its associated objectives, is two-fold. Firstly that, for each organisation, the achievement of this particular set of project objectives will contribute variously and to varying degrees to the wider goals of the organisation, thereby defining the degree of dependence of that organisation upon the effective achievement of project objectives. Secondly, that the achievement of project objectives, to the extent that it requires external interaction, will be mediated by the performance and contribution of the other organisation to which the first is linked in a contractual relationship. Consequently, the particular constellation of organisational goals, and the position and magnitude of project objectives with respect to those goals, coupled with the degree of functional interdependence between the organisations (Aiken and Hage 1968), will determine the relative 'balance of power' between those organisations in subsequent interaction. In other words, the relative importance of project objectives to the achievement of organisational goals will determine the organisation's dependency upon another (and hence its lack of power) to the extent that the other organisation mediates, through joint interaction, the goals obtainable. Following Emerson's (1962) scheme it is then possible to conceive of a continuum of states of dependency (and hence lack of power) of one organisation upon another: the mid-point would represent a state of 'balanced' or mutual dependency (and hence, balanced power) in the relationship between the organisations involved.

The picture presented here is complicated somewhat when account is taken of the possibility that the relationship between the

organisations extends to the performance of other projects and their associated sets of objectives. The discussion so far has focused entirely upon the subset of relationships associated with the performance of one specific set of project objectives. In doing so, the assumption of this being the only link between the organisations has tended to have been made. However, this may not be the case. In other words, the organisations may be linked together in a number of supply-demand transactions, and consequently engaged in a series of projects running end-on or concurrently.¹⁴ In such a situation, one needs to take account of both the breadth of activity that constitutes the wider relationship, and the length and importance of the relationship in a historical sense. Only by taking account of these factors is it possible to gain a fuller understanding both of the importance of the relationship to the parties concerned, and the significance of the particular project studied relative to that broader relationship. For example, one single project may be ostensibly of limited significance to organisation A, and one might presume this would lessen A's dependency upon another organisation B. However, if one takes into account the importance of the relationship with organisation B over past years, and the assumption that this may continue in future years contingent upon A's performance on this project, then the relative position of A and B changes quite considerably. Consequently, it is important to set the project and the objectives pursued in the context of a full description of the broader relationship between the organisations involved - including its historical patterning. Sayles and Chandler (1971) have gone some way towards this in their exposition of the interorganisational dimension in the study of project management. Specifically, they

have looked at the association between 'sponsor' and 'satellite', and highlighted the (economic) significance of the relationship and its potential as a control variable in interorganisational relations. They suggest an operationalisation of the construct based jointly upon: (i) the extent to which the project 'sponsor' monopolises the work of another organisation; and (ii) the extent to which 'satellite' organisations monopolise the performance of one of the sponsor's key functions (ibid, Ch 4). To some extent this formulation allows for the importance of the relationship as a whole, as well as that of the current transaction, as the two elements of primary importance (Hall et al 1977, 1978, Schmidt and Kochan 1977). However, the foregoing discussion would suggest that the historical basis of the relationship might further be incorporated in order to avoid being left with too static a picture of the association. Furthermore, following Emerson's (1962) and Blau's (1964) schemes, added attention might profitably be directed towards assessing the nature and extent of the alternatives available to each party in that situation. Both factors would perhaps present a clearer and more extensive picture of the dynamics involved in the background to the current interorganisational relationship.

2.5.3 Goals and Power in External Matrix Systems

The foregoing discussion has noted the centrality of goal dependence and power relationships to the study of interorganisational networks, and related them to the type of setting found in project systems. It seems appropriate at this point to return to the original question of the implications for the study of matrix phenomena of differences in internal and external relations. Further,

attention will then be directed towards the mechanisms established in the form of the relationship itself aimed at achieving some level of inter-organisational co-ordination and integration.

It will be recalled that, central to an understanding of the emergence or establishment of complex organisational forms, were the problems associated with differentiation (especially with regard to goal divergence), and power differentials among subunits (Galbraith op cit). The essential point to be made here is that, in an interorganisational setting, it is organisational, as opposed to functional disparities in goals, values, norms and power that form the critical nexus in the pattern of interaction in a matrix setting. This is perhaps illustrated by first addressing the concept of differentiation in an interorganisational setting. In this case a clear prominence attaches to the degree of goal divergence between the parties in the context of an economic transaction between the organisations, which is perhaps not apparent in the same form (or at least to the same degree) in an internal setting. It is simply that, in a supply-demand transaction between organisations, the parties will be operating under at least partly-conflicting goals, and will tend towards representing divergent economic interests. One might expect differences across other dimensions (eg functional goals, time orientations, formality of structure, etc) to be equally pertinent to the study of interaction across both types of setting, but not necessarily as salient a factor to those involved.

Disaggregating the concept of divergent orientations stemming from differentiation suggests a range of possibilities. For example, divergent goal orientations stemming from organisational

differentiation and the existence of a transactional relationship between the parties may be high (one party directly profits from the losses of the other). At the same time, similar functional perspectives may serve to minimise differences of view in problem-solving processes. A case in point may be the relationship between engineering sections in, respectively, the design and construction firms linked in a contractor-contractee demand-supply transaction. On the one hand, the commercial relationship suggests a divergence of interests; on the other, professional links may suggest a congruence of perspectives. (In the latter respect, orientations across organisational boundaries may actually converge much more closely than is the case in the relationship of each section with other sections or departments within their own respective organisation.) Following Thompson's (1967) scheme, contrapuntal tendencies towards shared "cause-effect beliefs" but divergent "preferred outcomes", would lead one to predict "compromise" as the strategy of resolution in decisional processes. The difference in an external setting is *then* that the mechanism for adjudication or arbitration is based in the nature of the transactional arrangement that governs interaction between the parties, and is much more likely to involve the mobilisation of power differentials between them. In an internal setting, inter-unit power differentials may play an important part (in direct negotiation or 'lobbying' for example), but additional (hierarchical) mechanisms of co-ordination and control are likely to play the central role (eg the judgement or decision of a common supervisor).

There is a further, more subtle point to be made with respect to differentiation. While perspectives may be shared or not, in

an external setting where interorganisational relationships may be novel, temporary and transitory, whether this is so is not necessarily known. To some extent there may be a learning process associated with reaching an understanding of the differences in perceptions and attitudes held by counterparts in another organisation. In an internal setting, such divergencies may be large, but at least they are more likely to be known by virtue of the familiarity of the groups working together. In an external setting, such divergencies may be large or they may be small. But in the first instance, they are more likely to be to some extent unknown, and perhaps only fully appreciated as the relationship develops. In this case, initial interaction at least may be guided rather more by expectations and assumptions of others' likely response. In the above example, for instance, it may be perceived that "cause-effect beliefs" are unlikely to be shared, given expectations informed by the nature of the transactional relationship. In this case, the predictable outcome - again according to Thompson (1967) - is the need for an "inspirational" approach to problem-solving and decision-making processes. In an internal setting, in contrast, preconceptions may be more accurately informed by direct previous experience of working together.

The central part played by power differentials is likely also to represent a qualitatively distinct set of factors in an external, as opposed to internal, matrix setting. The need for 'balanced' influence in an internal matrix organisation is predicated upon the differential effects of levels of task uncertainty upon the power of subunits within the organisation (Galbraith op cit). Specifically, those performing 'uncertainty-absorbing functions' (March and Simon 1958) are seen to be more powerful, since other

personnel rely upon inferences drawn from data available only to those departments, and hence become dependent upon the knowledge and expertise of its staff. In the literature on matrix systems, it is technical level participants - in production and product or process design - that assume this mantle, since their knowledge, information and expertise is critical to the performance of the task. However, given the salience of the contractual dimension in an inter-organisational context, it might instead be argued that role-holders occupied with administering the business transaction between parties may become more powerful relative to their technical system counterparts, by virtue of the dependence of the organisations in this respect. Such a point has been expanded upon in some detail by Sayles and Chandler (1971). They found that "business system" requirements had implications for the respective power of role-holders and functional groups:

"Because it comes to serve a variety of unintended functions, the lower status, static, predictable but control oriented business system may actually dominate the higher status, dynamic, but less predictable technical elements."

(ibid, p28; emphasis added)

While one might argue here that their assignments of (perceived) levels of status are perhaps somewhat arbitrary, their general proposition and its implications for the respective power of role-holders holds some merit. The tendency they observed may be explained by the greater criticality of such functions in an inter-organisational context. More general research has indicated the greater relative power of those units within the organisation performing critical functions: Crozier (1964) noted this phenomenon

with respect to maintenance in his study of French organisations; Perrow (1970) in a study of twelve industrial firms, identified sales as the critical function and hence the most powerful. In the matrix and project management literature perhaps the tendency to equate 'uncertainty-absorbption' and 'criticality' in the functions performed by technical level participants needs to be addressed in more detail, if the models proposed are to have equal validity when translated into an interorganisational setting. (Furthermore, the discussion in the latter part of Chapter One suggested that, internally, there may also be tendencies towards "business system" power and control). The knowledge, information and expertise necessary to perform the task most certainly will heighten the part played by "technical system" staff in absorbing uncertainty - and hence place a premium upon the exercise of expert and informational power (French and Raven 1959, Pettigrew 1972). However, the net balance of influence may more favourably be tilted in the direction of "business system" role-holders, whose power rests on the criticality of their function for the immediate commercial success of the organisations engaged on the project. Perhaps through administering a fairly precise delineation of contractual terms and conditions and legal rights and obligations which reduce the susceptibility of the organisation to problems stemming from constraints and contingencies occurring through the actions of external parties. In other words, through being able to exert some degree of control over the potential impact of external factors. In this case, a general alternative proposition may be that it is those performing more certain subtasks that will be more 'powerful', since they have more 'facts' to back their argument, or because their tasks significantly constrain the actions of others. Examples

of this would include the constraining influence of budgetary control by financial personnel over research and development expenditure; or the influence exerted by production over sales staff stemming from tightly-constricted production schedules. In an interorganisational context, where the negotiation of packages of work and their details may be of central importance, one might expect that the possibility of such a factor coming to the fore would be enhanced.

2.5.4 Implications

These points are of significance, since an understanding of the motivational basis underlying interaction and its grounding in the nature of the relationship between participants or groups involved in the 'project system' has potentially important implications for the propositions made concerning appropriate and/or observed forms and processes of interaction in a matrix setting (see above, Chapter 1). The earlier referred to prospect of 'negotiated interaction' during taskwork (Kingdon 1973), for instance, has rather different connotations when applied to the processes involved in an external, as opposed to internal, setting. The preferences expressed for collaborative modes of interaction, rather than competition, may be more effectively realised internally than externally, where a supply-demand transaction forms the basis of the relationship. Similarly, in an interorganisational setting, differences in 'preferred outcomes' may become more highly salient in decisional processes, despite highly convergent views, or shared 'cause-effect beliefs'. More generally, the question arises as to what extent are the conclusions drawn with respect to the 'cultural' characteristics of the new forms of organisation appropriate to an interorganisational setting? Not only is there comparatively little time to achieve any 'cultural transformation', there are also likely to be few incentives

to do so given the transactional basis of the relationship. A further possibility that bears mention is that of a 'clash of cultures' between organisations linked in a short-term contractual relationship.

As part of the emphasis upon cultural norms, to what extent is the norm of authority based upon relevant expertise and knowledge realisable in situations in which "business system rigidities" (Sayles and Chandler 1971) may tend to govern interaction? Sayles and Chandler (1971) have alternatively noted that an overemphasis upon "business system" legalities in efforts to minimise the possible risk of failure, may result in managers accepting little interference in the form of suggestions for change or modification, being unwilling to share informational resources, and resisting attempts to make their activities 'visible' (ibid, Ch 14). Melchers (1977) has noted how such 'communication problems' were important underlying reasons for the bridge failures that he studied. Rather than treating such possibilities as aberrations to the norm, might it not be more accurate to suggest that they represent rational strategies given the nature of the relationship and the premium put upon managing the business relationship. In a contractual relationship, where the organisation is faced with task uncertainties stemming in part from dependencies upon the resource inputs, information or specifications supplied by external bodies, it may tend to be the more formal bases of influence - namely the terms and conditions of the contract - that play the central role.

A Further, and final, series of points to be made here concern the difference in the leadership role performed by the integrator in an internal and external setting. If one can conceive of 'leadership' processes as such being applicable in an inter-organisational setting, then one must needs take account of the differential motivational base that characterises leader-follower interaction in an external setting. In the "path-goal" model, for instance, subordinates' perceptions and expectations play a central part in transforming leader actions into outcomes, assuming situational conditions are equal.¹⁵ Fiedler's (1967) incorporation of the quality of leader-member relations as a contingency variable is a more direct, albeit less sophisticated recognition of the potential impact of subordinates' expectations. More importantly perhaps for the purposes of this discussion is the inclusion of 'acceptance' factors in the model proposed by Vroom and Yetton (1973). Due to the particular constellation of factors involved in an external matrix setting, the potential importance of this factor suggests a variety of possibilities. On the one hand, divergencies in goal orientation may make 'acceptance' more critical. On the other hand, the ability to make the parties conform to the contractually-agreed set of procedures may make 'acceptance' less critical (since the indominus party has recourse to formal mechanisms for resolving disagreements). In the first instance, a more 'participative' approach can be expected; in the second instance, a more 'directive' or 'autocratic' approach. Similar possibilities may hold in an internal setting. However, the point here is that the two situations vary qualitatively in the dynamics of the processes involved. For instance, assuming the first possibility - that

acceptance is more critical: in an internal setting the issue is one of generating consensus within the context of an internal structure of interaction to some extent accepted as legitimate; in an external setting the issue is one of generating a consensus within the context of a negotiated framework for interaction between the parties which may be less accepted as legitimate. It is the difference between the tendency towards a more normative-based framework for interaction on the one hand, and a more utilitarian-based framework for interaction on the other (Etzioni 1965). If one further assumes that the formal position power of the integrator is high in both cases (ie internal and external) then significant differences may emerge. In the internal setting, the tendency may be for this potential influence to be held in abeyance given the assumption that a relatively high degree of unity of purpose will serve to ensure that the 'best' decision is reached. In an external setting, however, such an assumption may not be held, and it might be rather the case that the threshold for pursuing a more direct and directive approach in decision-making, given the ability to obtain compromise based upon recourse to the formal mechanisms available, is much lower. In the former case a more participative approach prevails. In the latter case, the approach taken is more directive. In effect, the position power of the integrator in this instance serves as a 'substitute for leadership' (Kerr and Jermier 1978).

It is not the intention here to delve into more detail into the vast number of possibilities given the range of situational contingencies and their possible variation and interactions. Hopefully, the foregoing example serves as an illustration of the

possibilities in understanding leadership processes and how they may differ as between an internal and external setting. The general point to be made here is that, if one is to fully understand the nature and implications of leadership processes within a matrix setting, then one has to take into account the differing bases of motivation in internal and external settings, since motivation is central to an understanding of leadership processes. In not clearly differentiating between the two types of setting, the tendency may be to equate the processes involved, whereas in fact a need to differentiate between them is paramount if one is to be able to fully account for and predict the outcome of leader action.

2.5.5 Summary

In summary, it is useful to reiterate the main point raised in this section. Specifically, it is that the tendency to obscure the difference between internal and external systems of matrix management ignores a central point of departure in the power implications of transactional relationships between parties. It may well be that models of matrix organisation allow one to predict the greater power and influence of technical subsystem role-holders in an internal setting (alternatively, the points made in this section may have a good deal of bearing upon those raised in the previous section). However, and as Sayles and Chandler (1971) and others have found, it is not so easy to predict such an hypothesis in an interorganisational matrix system of roles and relationships.

Having addressed in Chapter 1 the concept of matrix management

and discussed its relevance to project settings, this chapter as a whole has sought to address a number of shortcomings and omissions in the theory and research upon matrix management. In particular, attention has been focused upon: the slim bedrock of empirical data upon which many of the models are based; the tendency to narrow the scope of investigation to individual sets of production activities and not to fully account for the potential implications of variation in group and organisational size; and the absence of a full and detailed discussion of the implications for matrix systems of an interorganisational dimension in the management of project-based activity. Chapter 4 will return in more detail to this latter set of issues and their implications for the forms and processes of interaction found in the management of construction project taskwork. In the meantime, the next chapter (3) is concerned with addressing the characteristics of construction activity, organisation and management in the light of the concepts introduced and discussed in Chapters 1 and 2.

Footnotes:

- 1 For a review of the relevant literature see, for instance, Hall (1982, Chapter 13).
- 2 Although construction firms were specifically excluded from the sample.
- 3 The research programme and findings have since been compiled in four volumes published by Gower Press (Pugh and Hickson 1976, Pugh and Hinings 1976, Pugh and Payne 1977, Hickson and MacMillan 1981).
- 4 For a more complete explication of these dimensions see, for instance, Pugh et al 1968.
(NB Later versions of the model added a sixth dimension
- standardisation of employment practices (cf Pugh 1973.))
- 5 For a fuller critique of the structure-technology approach see, for instance, Perrow 1979, pp168-70.
- 6 The earlier point made concerning the relationship between task uncertainty and informational requirements is of some relevance here. Specifically, whether the capacity to process information is fully synonymous with the concept of knowledge technology would appear to be a critical question that is not fully addressed in the matrix and project management literature (cf Galbraith op cit).
- 7 A broad description compatible with the findings for unit production firms from Woodward's (1958) study.
- 8 The point of course also applies to the earlier-discussed relationship between technology and structure.
- 9 The simple fact of exponential changes in the number of possible interactions as the number of participants increases (Caplow 1964) suggests the potential importance of group size in a setting in which 'networks' of interaction are deemed appropriate.
- 10 For a more detailed discussion, see for instance, Thompson (1967).
- 11 Interorganisational theorists have taken the concept of "domain" as defining the relative position of the organisation - and hence the nature and extent of its roles and relationships with respect to other organisations - within a broader "technological matrix" (Thompson 1967, Levine and White 1960, Emery and Trist 1965).

- 12 The focus here is upon contractual relationships in a competitive market situation. The emphasis is upon "voluntarism" (Warren 1972), whereby a relationship is formed when both parties perceive mutual benefits from interacting (Levine and White 1961, Tuite et al 1972). It should also be noted, however, that an alternative rationale lies in the possibility that a relationship is formed when one party is powerful enough to induce the other to interact (Yuchtman and Seashore 1967, Aldrich 1972, Kochan 1975).
- 13 Emerson (1962) suggested that the dependence of an actor (here: organisation) A upon another actor B provides the potential for B to exert power over A, since B controls the resources that A requires. Power, therefore, is an inverse function of the degree of dependency, and arises directly from the nature of that dependency. He defined dependency as being directly proportional to A's motivational investment in goals mediated by B; and inversely proportional to the availability of these goals outside the A-B relation. Blau (1964, pp118-125) has extended Emerson's ideas to a set of four conditions that should foster the independence of A from B: namely the essentially and substitutability of the resources offered by B (see also Jacobs 1974); A's control over strategic resources; and the ability of A to use coercive power to secure B's resources.
- 14 Further, it is possible to conceive of situations in which the directionality of the supply-demand transaction is reversed in some of those relationships.
- 15 Based on Vroom's (1964) expectancy theory of motivation, attention is directed towards the valences attached to a specific outcome and the probability of its occurrence. Two sets of expectancies - that effort will lead to performance, and that performance will lead to reward - serve as the postulated mechanisms (House and Mitchell 1974, House and Dessler 1974)

CHAPTER THREE

MATRIX MANAGEMENT AND THE CONSTRUCTION PROCESS

The application of the concept of matrix management to an understanding of the processes involved in project organisations in general (eg Cleland and King 1975), and in construction project organisations in particular,¹ has been considerable in recent years. The aim of this chapter is to address the applicability of a matrix management framework in the investigation of processes of construction management by focusing upon the task that is performed in construction and its distinctive characteristics. In doing so, attention will be directed towards the applicability of matrix concepts at two levels of analysis within the type of setting studied here: namely, intra- and inter-organisational patterns of communication, co-ordination and control of project taskwork. As noted above, the literature already cited focuses generally upon the single organisation as the unit of analysis in investigations of the phenomena of matrix and project management. This study, in contrast, focuses more directly upon the project organisation itself that is established to undertake project work. However, the centrality of intraorganisational variables to a study of the processes involved in an inter-organisational project context necessitates also a full consideration of the circumstances facing the individual firm or organisation in external interaction in a complex and dynamic task environment. Consequently while this study focuses upon the organisation and management of construction projects, as opposed to construction (and/or design) firms, a consideration of the latter is of equal importance since it may serve as a critical component in defining the position of one organisational team vis-a-vis the other(s) within the wider project team. Consequently before attention is directed towards

the fact of "organisational differentiation" within the project team (Morris 1972, 1973) attention will be turned briefly towards the task undertaken by individual construction organisations within a construction context. For the purposes of this discussion, the focus is upon the construction firm, rather than upon firms specialising in design activities. However, it should be noted that much the same implications of the nature of the task and general product market conditions are expected to hold for firms engaged at this stage of the total project 'cycle'. The major difference here is that the 'production system' employed is to some extent separable from the geographical location of the product being built (ie whereas construction takes place on site, design activity may be undertaken in drawing offices located elsewhere). With this exception, other conditions - the design of a one-off product to a client specification over a definitive timespan - are expected to hold and to have similar implications for the organisation and management of design work as for the organisation and management of construction work. The interdependence between these two sets of activity and associated patterns of integration forms the main thrust of the later section.

3.1 Construction Task Characteristics

The first set of characteristics to be noted about construction taskwork is that a unit-based system of production, in which individual projects are custom-built to client specifications, is the supply mode common to most types of construction activity. Individual projects may involve the mass repetition of individual subunits: eg virtually identical units in a housing estate development project; or identical classrooms in a school building. However, taken as a whole, the project

involves the construction of a unique one-off product (ie the estate; the school) custom-built to a client's specification. In these examples, similar previous and future-planned estates or schools undertaken as a series of contracts in a 'rolling' programme of development, may heighten the tendency towards what may be interpreted as implying more of a 'large batch' system of production (Woodward 1958, 1965). Consequently both within the scope of an individual project and across serially-linked projects some degree of similarity and repetition in the type of output produced may be apparent. However, the essential feature is rather some degree of discontinuity and dissimilarity in the types of outputs produced both within and between projects. In part this may reflect differential client specifications, or, within the scope of one project, a more variegated and idiosyncratic specification for subsections of the work (eg variation in the dimensions for individual houses' rooms or classes). This feature is discussed in more detail below. However other basic distinctions may also occur due to two inherent and distinctive features of the task being undertaken: its spatial and temporal aspects. The difference lies in the differential location - both spatial and temporal - of the production activities that are involved. Rather than a system of production operating in which the processes of production themselves are relatively fixed and static (as in the case on an assembly-line in a factory system of production), the production processes themselves must needs be applied both where and when the products (and their constituent parts) are to be produced. In other words the process of production is to a large extent inseparable from the geographical and temporal location of the output that is produced.

The actual location of the task being performed is one salient and key characteristic which marks off construction activity from the type of work undertaken in perhaps otherwise comparable product market conditions (eg research and development projects; the manufacture of engineering prototypes; etc). In construction the finished product (eg a building) is non-transportable and is produced at the point of consumption. This is a particularistic characteristic of the conditions of demand within the industry, and one which has profound implications for the form of production system and organisation observed:

"While some work may be prefabricated in factory conditions, the building or other structure must ultimately be provided at a particular location, fixed as it were, to the site ... Thus the advantages which firms in other industries may gain from centralised production in factory conditions do not apply in the construction industry."

(Fleming 1980, pp231-2)

Since the demand for the firm's products is conditioned in this way, both the system of production employed and the organisation to directly manage that work are necessarily dispersed geographically, and specific to where the product is to be used. A further, and consequential, important aspect here is that physical environmental conditions play an important part in the production process itself. The actual geo-physical conditions on site may influence to varying degrees what is built and how. For example, ground conditions (eg water levels, subsidence), may determine the need for a particular type of foundation, or affect the manner in which it is put in place. More generally, the process of production is influenced by the nature of the task environment

in a very direct and physical way: namely, via the weather. Unlike conditions in a factory-based system of production, where the physical environment is to a large extent controllable, in construction it is not. Indeed, the products of the construction industry include those (eg factories) which allow such conditions to be controlled. As noted in the above quote, constituent parts may be, and often are, prefabricated under more controllable (factory system) conditions. However, in large part, the industry continues to be one in which in situ construction is the norm (Bishop 1972).

Moreover, the construction of the total product on site involves necessarily the on site assembly of prefabricated or 'system' components. In relation to the earlier point concerning production system variation within and between projects, the point here is that geophysical properties, in varying from one part of the site to another, or between sites, may have implications for the processes of production involved. For example, two otherwise identical housing estates (or two sections of one estate) may involve quite different processes of construction by virtue of the difference between the ground conditions at each site.

The second major characteristic of the construction task, shared with other types of project, is its transience. Each project will have its own 'life expectancy', manifested in an end completion date after which no further activity is expected or warranted.² The timespan may vary as much as between, say, six months and six years. However, it is the finality afforded by a completion date that sets aside construction (and other forms of project) activity from that found in more permanent settings. Production runs in a

factory may be short or long. However, the production system itself (and the organisation) is unlikely to be disbanded or moved elsewhere once these runs are complete. Rather the system is modified (or left unaltered) to undertake other product runs. In construction, the transience of project work, coupled with its location-specific orientation, means that these are necessarily the preconditions for the performance of a new task. As such there is comparatively little continuity in the form of production system established between projects. Each construction project marks the establishment of a new and temporary production system and organisation located at the point of consumption. Taken together these conditions mean a substantial reduction in the scope of construction firms to achieve technical economies of scale (Fleming 1980, p236).

The temporal dimension complicates matters further if one then takes into account within-project characteristics. Taken as a whole, the project 'cycle' originates from the conception of a product to be built, and develops through broad and detailed design stages, through to construction on site and, finally, commissioning, occupation and use (eg Wearne 1973). Taking one part of this - the construction process itself - the eventual product (in the case of a building) is 'built up' through the establishment of foundations and substructure, the erection of a superstructure, the external and internal finishing of the work, and the installation of services, fixtures and fittings. These activities may, of course, be undertaken in sequence or in parallel, depending upon the pattern of interdependencies and resource and technical constraints. However, overall, there is an essential linearity in the process, based upon the logic of a chronology of activity in the building of the total product. What this means is that construction (and other project) activity on site is essentially unreplicative in nature. The degree of repetition and

standardisation of product output observable in factory systems is unobtainable in a construction project setting. The production processes involved between projects may be essentially similar. However, the continuity necessary to take advantage of this degree of routinisation is restricted due to the fragmented nature of activity in time and space. Within the scope of one particular project, the range of activities undertaken, and the variety in the production processes involved (and perhaps also the different temporal location of like activities at different points in the construction cycle) means also that discontinuity and change in the basis of activity, rather than continuity and stability, is the norm.

The type of production system employed in construction, in its relationship with product market demand characteristics, is therefore highly distinctive from other types of production system found in more stable and permanent settings (and distinctive, perhaps, from other forms of project activity by virtue of its geographical dispersal and the influence of physical environmental conditions³). In terms of the resources and production techniques employed, it should also be noted that this lack of 'systematisation' of the production processes that are involved has meant that construction work still remains somewhat 'traditional' in its production techniques and methods, and that a continuing premium is placed upon the skills of skilled craft labour - to an extent that is not as apparent in other types of production system.⁴ The early depiction of construction as a craft-based system compared with the bureaucratic systems found in other industrial settings (Stinchcombe 1959) still to a certain extent holds.

These characteristics of the task being performed present particular problems of organisation for the firm involved in construction work.⁵ Above all, they imply the need to create or put in place, series of local and temporary organisational units in order to manage construction activity. For the firm as a whole, its operations may be highly geographically dispersed in relation to its 'core' central administrative organisation. Further, at any one point in time, the firm is likely to be engaged in performing a series of project tasks at various points or stages in their overall project (and construction) 'cycles'. It is this degree of spatial and temporal disjuncturing in the firm's mainstream task activities and the fact that individual projects are the focal unit in the firm's calculations, that makes the construction situation somewhat distinctive in the strategic options available to the firm in designing an appropriate managerial and administrative structure.

The first point to be noted here is that these constraints in the nature of the task being undertaken predispose the firm to specialise, at the level of its separate project activities, according not only to the particular project (ie product-basing), but also to the particular client, location and time span of activity. In other words, specialising at the level of operations according to the product, client, location and time are inherent in the nature of the work being performed. The production system and organisation which is established on site to perform and manage task work is specific to that project (and its client), its territorial location and timespan (Miller 1959). While it is theroretically possible, it is highly improbable that the firm will

choose to manage the project by appointing two separate teams: to undertake either two sections of work on the same site (each team performing comparable work on another 'split' local site), or two different stages in the construction process.⁶ The need to co-ordinate activity specific to the construction of a particular project will militate against this happening.

Above and below the level of the site, of course, different organising principles may be apparent. Within the scope of the project, work may be organised according to the processes of construction involved, or the subproducts being built and their location (for example, exercising the choice between constructing sections of a housing estate in sequence (process) or in parallel (product and/or place). However, it should be noted that even here this choice may be effectively constrained by explicit or implicit demands posed in the original client specification. For example, the specified time period available may heighten the efficacy of a product, as opposed to process-based form of organisation (if certain sections of the work are to be 'handed over' to the client at interim completion dates). At the level of the firm as a whole, operations may be grouped geographically in regional divisions; by product (eg housing construction as against non-housing construction and civil engineering works); in certain instances, according to the client (if one or a group of clients are sufficiently important and/or regular customers); or perhaps the processes involved (eg establishing separate divisions for main trades construction and services). One would expect that the need to integrate closely the processes involved on a project by project basis to again militate against this latter possibility.

However, many examples do occur.^{7, 8}

The point here is that, at the level of the site, the nature of the task being performed constrains the options available to the firm in organising its operations on a company-wide basis. In turn these constraints present problems for the firm in their patterns of internal resource allocation.⁹ The materials and plant required to undertake project work are likely to some extent to be idiosyncratic and project-specific. The firm may hold stocks of such, however the variable pattern of demand and its specific characteristics mean that at any one point in time there is unlikely to be any easy direct match between the level and types of materials and plant held and those needed to undertake work across the range of the firm's operations. Furthermore, depending upon the pattern of the firm's activities, bottlenecks and excess capacity across the range of (un)needed plant and materials are highly likely. More importantly, the constraints stemming from geographical dispersion and temporal fragmentation of the firm's operations, make it highly probable that problems emerge in having 'the right people available in the right place at the right time' (or conversely, in there being excess managerial and workforce capacity). To the extent that this is the case, and to the extent that projects differ in their size and type (and hence personnel requirements), then the aim of achieving some degree of continuity and consistency in employment patterns from one project to another becomes a difficult exercise.¹⁰ In other words, the establishment of an organisation for the performance and management of construction work on site is itself to some extent a unique and novel exercise.¹¹ Consequently, there are problems for the firm in matching up the

demands for, and supply of, personnel across the current range of work available, and in maintaining some degree of continuity and stability across the current and prospective range of operations that are undertaken by the firm. In having to organise and manage work on specific projects that are often distinctive in nature, dispersed geographically and temporary in duration, there is a tension between the orientation that this suggests towards the specific project on the one hand; and the longer-term processes of resource allocation consistent with achieving some level of administrative efficiency and the economies of scale through the functional specialisation that may accrue on the other.

3.3 Project Organisation Forms

It is this element of duality in orientation, which is the hallmark of the matrix management systems described above, which makes for the applicability of a matrix scheme to a study of internal processes of management at the level of the construction firm. The dual orientation stems from the commitment to immediate project objectives and conditions that vary from one project to another; and the simultaneous need for continuity, stability and development of the firm's administrative specialisms in order to achieve a high degree of efficient internal resource allocation within the organisation as a whole. If one assumes for the moment high levels of task uncertainty and interdependence (returned to below), then following Galbraith's scheme, the firm is faced with three broad strategic design options in organising its project task work. The first is that each project operates as a "self-contained task" (ibid, 1973). However, in situations such as construction, where over time and space the firm's broad range of operations consists of projects in which essentially

similar operations and functions are performed (for instance, estimating and network planning activities), one would expect this to be a costly strategic option for the firm. While specific projects may be highly idiosyncratic in nature, the fact that the firm's operations consist in their entirety of such projects makes for a degree of relative continuity and consistency in the application of techniques and procedures from one project to the next. In other words, variation in substantive content rather than managerial procedural mechanisms is the norm. While each project may need to be approached in a different manner, this does not mean that treating it as fully distinct from the firm's mainstream activities and hence organising in such a way that it were regarded as a completely unique, one-off experience, never or rarely to be repeated, is the appropriate strategic response. Certain instances may occur in which this is a possibility (for example, a large-scale one-off design and construction project being undertaken by a firm which has formerly been involved only in 'traditional' contracting). However, one would expect these to be rare and, by definition, exceptional cases.

The second possibility is in organising fully and explicitly on a project by project basis (ie a fully product/ project - divisionalised form). Again, however, one would expect this to be a costly strategy and one which is only rarely, if ever, encountered in practice. Unless an individual project is sufficiently large (and that individual client and their project is of sufficient size relative to company turnover), then it seems unlikely that the conditions faced by the firm allow for a full product (ie project) orientation in its divisionalisation strategy

or general configuration. The comparatively small-scale of most individual project operations makes costly the full disaggregation of specialised activities (eg estimating, planning, etc) and their attachment to specific projects; and, conversely, the more cost-effective their concentration in centralised service departments providing specialist support services to the range of operational units in the field. One might expect that some very large projects are sufficient in scale to warrant the additional overheads and, thereby a closer approximation to a product-divisionalised form. Indeed, examples cited of very large scale construction projects do give illustrations of a more decentralised and self-contained project organisation consistent with the tendency towards a more explicit product-orientation (eg NEDO 1970).

Consequently, project size is likely to be of significant importance in this respect. However, such examples are again likely to be comparatively rare, and where they do occur, still to some extent functionally-linked with other projects through the co-ordination activities undertaken at central office level (eg in allocating and administering large scale plant between projects). In the mainstream of construction activity, it is rather some degree of 'balance' in the management functions performed by site and head office personnel that is the more likely possibility. In particular, it is the balance between on site production capacity and off-site planning and administrative support capacity (ie estimating, planning, engineering design services, resources allocation, financial and contractual management etc), that in practice tends to occur (eg Ward 1979, Kavanagh et al 1978, Harris and McCaffer 1983). In construction management, the performance of work on site constitutes only a part

of the total 'cycle' of project activity. Prior to that stage, the firm is involved in estimating and placing a tender for the work with the client, in planning out the work, designing and detailing known and agreed processes of work, arranging to some extent the pattern of resources flow to the site (including selecting the site management team and appointing subcontractors and suppliers), and agreeing and arranging the details for the administration of the contractual set of terms and conditions. (Following the construction process, the final settling of accounts and claims constitutes the final set of acts with respect to this latter function.) As such, and to the extent that a degree of continuity in performing these more general functions in a supervisory capacity continues throughout the construction part of the 'cycle' as a whole, then the conditions are set for the possibility that some form and degree of matrix management, with respect to the performance of specialised functions provides a framework for understanding the process of construction site management.

It is not the intention here to address the question of what particular forms will be apparent, or how these may be conditioned by levels of task uncertainty and interdependence in the performance of construction work on site. It may be that the forms observed will range from relatively 'weak' functional authority patterns (eg with respect to, say, resource acquisition) through to the more direct line control of site staff (eg engineering and surveying specialists). Further, it is not intended here to speculate upon mechanisms of integration and the nature and bases of interaction. These are empirical questions reserved for the later case descriptions and their analysis. The proposition that is suggested here is rather more general. Namely, that high levels

of uncertainty and interdependence in the nature of the task being undertaken will predispose the organisation to maintain and operate an organisational framework within which explicit or implicit tendencies towards a matrix system of roles and relationships will be apparent. The earlier-noted relevance of organisational size as a conditioning factor also suggests a further proposition. Namely that these tendencies will be more apparent to the extent that the size of the project allows for a disaggregation of specialised activities performed to the level of the site. In other words, the larger the scale of the work, the more likely that specialist staff performing specialised functions will be seconded to the site team to perform these activities. Consequently the more explicit will be the tendency towards a dual structure of roles and relationships on site. In making this proposition, the starting assumption is that more generalistic, 'production management' staff are those most directly involved in managing the overall process of construction on site. What is being suggested here, in effect, is that the more extensive the pattern of secondment of specialist staff to the site, then the more one moves away from a 'secondment' towards an 'overlay' or 'co-ordination' model of matrix management (Knight 1977). Given these terms, the semantics here are somewhat confusing. However, the main point is that the latter represents the tendency towards a more dispersed and shared pattern of authority and control on site. The possibility this gives rise to is depicted in Figure 3.1(a). (The comparable situation for a design firm is depicted in Figure 3.1(b).) It should be noted that these diagrams only give illustrations of two sets of broad possibilities. A multitude of variants are possible, given the

Figure 3.1 Intraorganisational Matrices of Roles and Relationships

(a) Within the construction organisation:

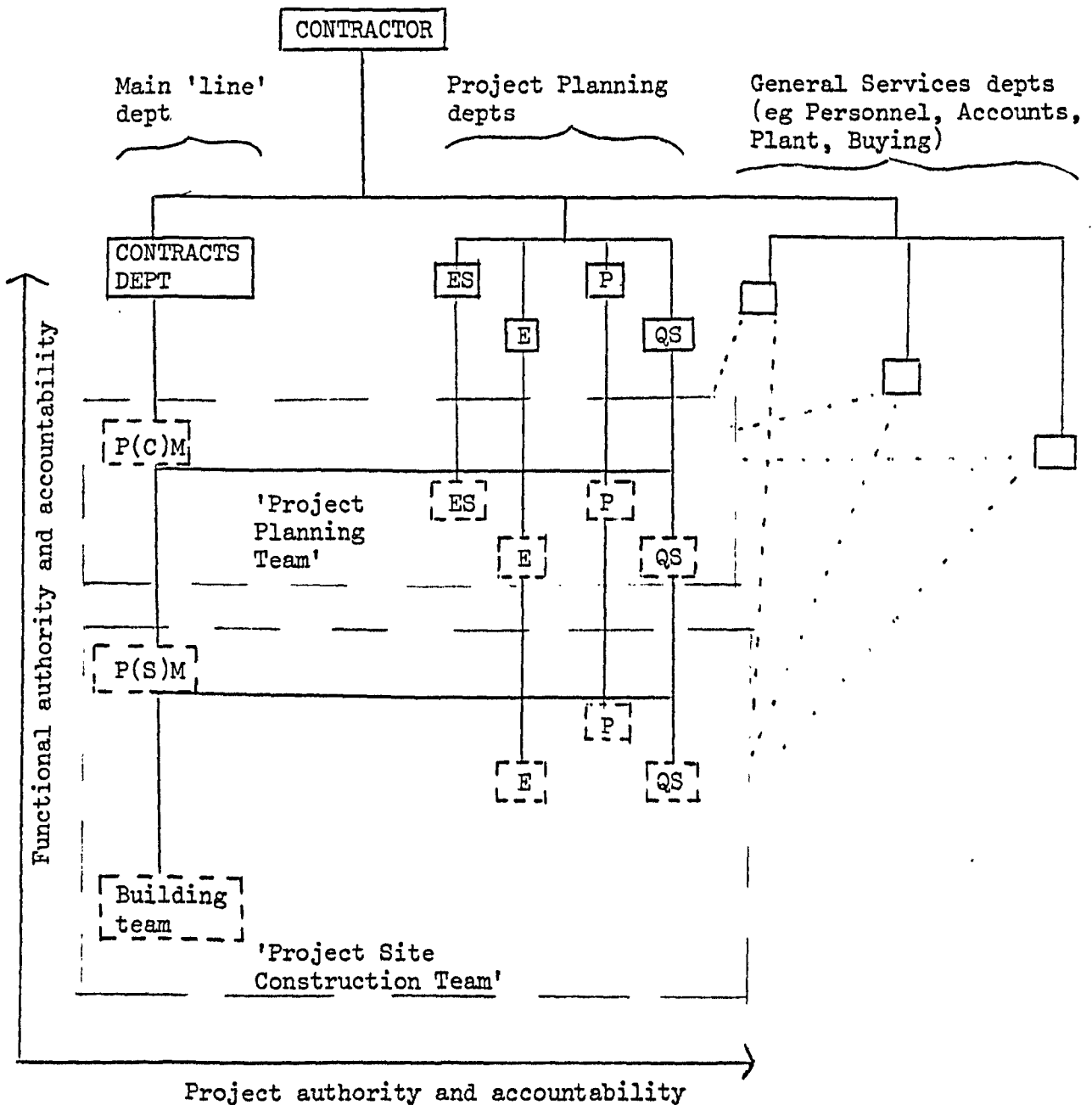

- KEY: P(C)M = Project (Contracts) Manager
 P(S)M = Project (Site) Manager
 ES = Estimator
 E = Engineer
 P = Planner
 QS = Quantity Surveyor
 [] = Functional Department or individual
 [- -] = Task Group Representative
 — = 'Line' Management Relationship
 = 'Staff/Service' Relationship

Figure 3.1 Intraorganisational Matrices of Roles and Relationships

(b) Within the client organisation:

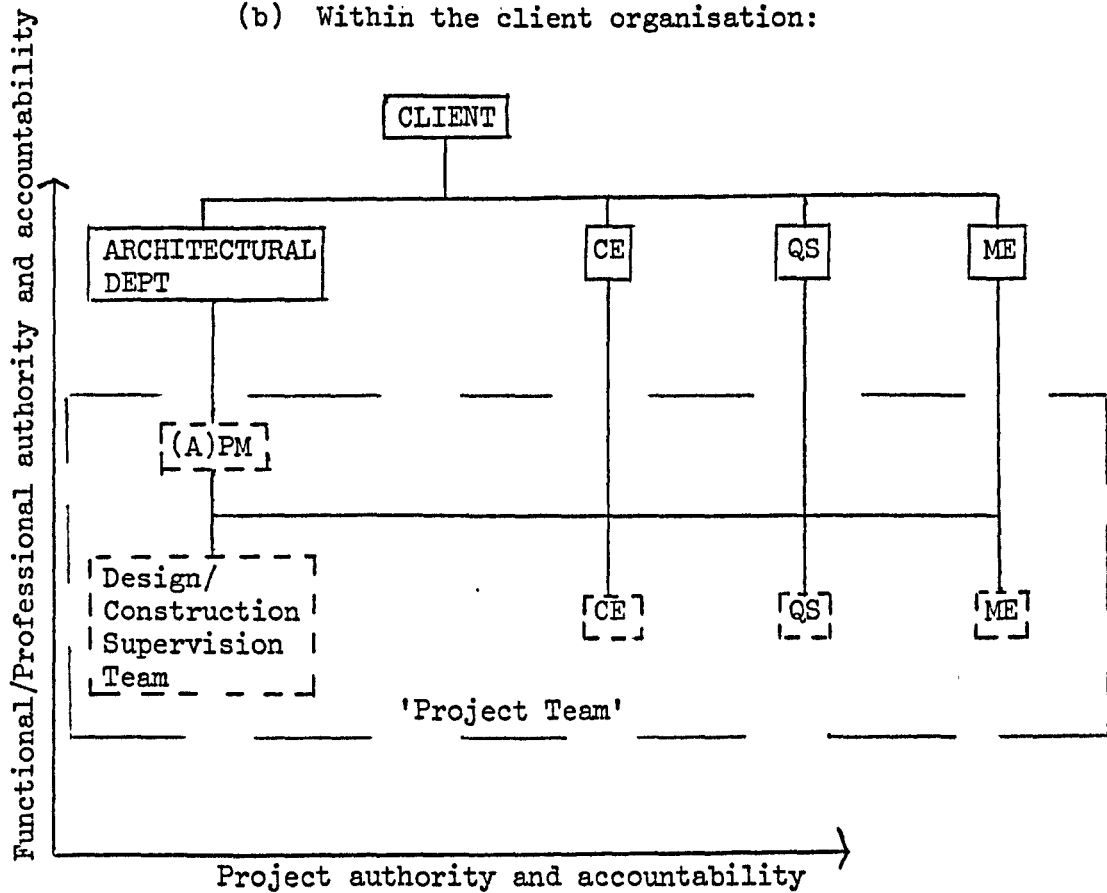

- KEY:
- (A)PM = (Architectural) Project Manager
 - CE = Civil/Structural Engineer
 - QS = Quantity Surveyor
 - ME = Mechanical/Electrical Services Engineer
 - = Functional/Professional Department
 - = Task Group Representative
 - = 'Line' Management Relationship

particular configuration of roles and relationships within and between departments and sections within the wider organisation. In particular, the extent to which production staff 'project managers' have direct 'line' authority over project team members has been simplified for purposes of illustration to the position in an 'overlay' model of matrix management (Knight 1977).

3.4 Task Uncertainty and Interdependence

Investigations of the nature of task activity undertaken in construction have indeed taken as their starting point high levels of task uncertainty and subtask interdependence as highly salient features of the construction process on site (eg Higgin and Jessop 1965, Crichton 1966, Morris 1972). For the construction firm involved in constructing a building or other type of structure, technical uncertainties stem from the geophysical conditions on site. Also to the extent that the resources and techniques are project specific, and perhaps untried and untested, then the means of achieving project objectives may to some extent involve technical uncertainties. However, perhaps by far the greater source of uncertainty may lie in the nature of the product specification itself and the constraints for the process of production that this implies, rather than in the processes of production per se. Specifically it is the nature and degree of product and process specification over which the construction organisation has no formal, direct control that provides an important source of potential uncertainty.¹² Other technical problems apart, the consistency of design plans with extant site conditions, and the variability of those plans as either conditions change, details are clarified, or variations are introduced make for a situation in which extensive 'feedback' mechanisms in the construction process between construction and design activities tend to be appropriate (Crichton 1966).

Levels of subtask interdependence are also high, to the extent that physical and technical conditions require the close co-ordination of separate trades' work across the site as a whole. This will particularly tend to be the case to the extent that the amount of time available to perform specific tasks is constrained. For example, plastering and painting internal walls are sequentially-linked processes: painting follows on from plastering. If the overall programme is 'tight' however, the processes may become more tightly-coupled, any problem in the execution of the former having knock-on effects in the performance of the latter. A parallel set of activities may be involved in the installation of internal fixtures and fittings: eg lights, power points etc. Here, moreover, the processes may be reciprocally-interdependent: the space left in plastering sets constraints for the installation of electrical cablework; the installation of cables affects the finished quality of the plasterwork. If one adds to this the possibility of design variations (in the colour specification for paintwork, and the location of lights and power points respectively, for example), then the implications for the established plan of work should be obvious.

These examples are given as very specific and simple illustrations of the tendencies towards conditions of uncertainty and inter-dependence in the performance of task work on a construction site. The general implication, broadening the focus to the managerial processes involved, is that project planning, co-ordination and control processes related to the performance of taskwork on site are subject to the complexities of these interdependencies and the propensity for change that are characteristic of the construction process. The tendency for change in particular stems in part from the constraints and contingencies

arising through the geophysical conditions on site, and also perhaps from properties of the resources and techniques employed in the 'transformation system' (Kingdon 1973). However, it is also, and perhaps most importantly, the propensity towards lack of full coverage or clarity, and to change in detail in the product specification itself (with its implications for the processes involved) that marks the distinction of the construction process as a unit-based system of production from perhaps other forms. The industry does not occupy a position on a plateau of high technology as is the case in the matrix systems commonly discussed. However, its distinctive product and process characteristics do mark it out as a type of situation in which complexity, variability and high levels of interdependence in the performance of taskwork are salient features.

At the broader level of analysis, what this suggests for the firm is a reliance upon the technical and managerial expertise of personnel performing the work at the operational level (and hence the decentralisation of discretionary, decision-making authority to those 'on the ground'); coupled with the retention of some degree of centralised control over the management of the project as a whole. Corresponding tendencies towards a more 'organic' system of management at site level have been extensively commented upon in the construction management literature. Birrell (1981), for instance, describes the "informal organisation" which performs and manages construction site activity (comprising main contractor and subcontractor staff) in terms of extant processes of communication between the parties and their representatives. He stresses the importance of a participative approach by site managers and the importance of relationships of confidence and trust between site representatives and head

office staff, and between the main contractor's site manager and subcontractors' representatives. Interestingly, however, his description of an "axle and spoke" pattern of communication stands in some contrast to the network communication structures deemed appropriate in the 'organic' model. A similar, strong emphasis upon participative strategies at all levels in the site hierarchy, is found in the work of researchers investigating motivation and productivity performance on large sites (eg Borcharding 1977, Borcharding, Sebastian and Samuelson 1980, Borcharding and Garner 1981).¹³ The efficacy of a participative approach for quality performance on site has also been noted (Freeman and Bentley 1980).

With respect to change and variability in the processes of construction on site, Hatchett (1971) has noted the need to allow for what constitutes a "dynamic learning system" of production on site, and has contrasted this with the somewhat static procedures and mechanisms that tend to be employed by construction firms for the monitoring and control of site activity. A similar emphasis upon the developmental and changing features of construction site activity is found in the increasing attention given by researchers to transience and change in the management of site project work (eg Sozen 1981, Eguchi 1981, Halsey and Margerison 1978, Bryman et al 1986). At a broader level, an interesting set of findings with implications for the line of argument pursued here have been obtained in an historical analysis of work organisation in the French construction industry since the war (Campinos - Dubernet 1985). The research questioned the assumption of the 'traditional' nature of construction activity by pointing to the extensive fragmentation and division of labour within the industry since market conditions changed over the 1960's. (It should be noted

that Stinchcombe's (1959) analysis is grounded in the association between the form of work organisation found in construction and market conditions). The researchers noted how the need to allow flexibility to cope with variability in construction processes had historically been met by a more decentralised control system in which "semi-autonomous groups" or gangs led by foremen played the central part in controlling the performance of work on site. As conditions changed over the 1960's (the market becoming 'tighter'), efforts to adopt an orthodox Taylorist system of production control were instigated, but were limited and met with little success. However, more direct control over the performance of work on site was developed through greater specialisation in site management activities (site managers succeeding foremen as those in direct control), and through the establishment of work study 'packages' (in planning, estimating) available to site management on a 'consultancy' basis. It is interesting here to compare the similarity of this process with the developmental models of matrix management discussed in Chapter 1 above: control over the performance of taskwork on site, where a "semi-autonomous group" system of working was necessary, was sought via external forms of regulation manifested in a pattern of functional authority and influence over the performance of work on site.

A similar related tendency has been noted towards the adoption of more sophisticated planning and control systems, and away from the characteristic 'ad hoc' approach that tended to characterise construction project activity through to the 1960's when more 'turbulent' economic conditions emerged (Lansley 1981). It is beyond the scope of this thesis to consider the design and use of informational systems to aid the processes of estimating, project planning and control. The

literature is extensive and the methods and mechanisms adopted are more fully discussed elsewhere (eg Cleland and King 1975, Burman 1972). However, it is pertinent to note the correspondence of this historical development due to more 'turbulent' conditions, with the developmental strategy described by Galbraith (op cit) of responding to conditions of increased task uncertainty by investigating in vertical information systems. The points just raised may suggest that the two developments (matrix management and computerisation) have been complementary strategies adopted by construction firms over time to cope with conditions in an increasingly 'turbulent' product market environment.¹⁴

The juxtaposition between matrix management forms and the employment of sophisticated informational systems in construction finds expression in research undertaken in 20 firms in the Turkish construction industry (Arditi and Kutay 1981). The researchers adopted (and adapted) the Aston scales to investigate tendencies towards matrix management between 'user' and 'non-user' companies of network (systems) planning and control techniques. They found that the former group of firms exhibited tendencies towards more 'structuring of activities' and greater 'decentralisation' (Pugh et al 1968). Also they exhibited fewer management levels and were larger in size than 'non-user' companies. They concluded that these firms exhibited greater tendencies towards a matrix system of management. However, the results and interpretation put on them are by no means convincing. Firstly, the structural attributes employed as dependent variables (eg decentralisation) are not necessarily symptomatic characteristics of a matrix structure. Matrix organisations may well be more decentralised, but not all decentralised organisations are matrix in form. There was no evidence given of a duality in structure: the

necessary condition for a matrix system. Given this omission - of the constructs central and necessary in an operationalisation of the matrix concept - one might well conclude that the firms varied simply according to their degree or type of bureaucratisation. Secondly, the finding of a greater degree of structuring of activities in 'user' firms, suggests perhaps the opposite to what one might expect in a matrix organisation. Given that such firms were also larger, the correspondence between the higher degrees of 'structuring' and 'decentralisation' is by no means incompatible with the findings for large bureaucracies (see above, section 2.2). In a matrix organisation, moreover, one would expect activities to remain comparatively unstructured, reflecting a reliance upon professional and technical discretion in interaction, and the adoption of less 'obtrusive' mechanisms of control. In other words the findings contradict the interpretation put upon them. Thirdly, it is unclear as to why the adoption or not of network systems should be taken as the central differentiating variable. Arditi and Kutay (1981) relate this to the occurrence of a 'task culture' within the firm. This may be true. However, as noted in Chapter 1, differing types of culture may be conducive to differing forms of matrix organisation. More importantly perhaps, the use of network systems corresponds to Galbraith's (op cit) option of greater investment in vertical information systems - a complement or alternative to the extension of lateral relations in a matrix system. The association between system usage and greater structuring of activities is then consistent with the results: the use of such a system may in fact be associated with a greater structuring of activities within the firm as a whole, in which case more 'obtrusive' mechanisms may take the place of the more 'organic' system of management presumed to characterise a

matrix setting.

Before continuing further, it is useful first to summarise the main point raised in this brief review. It is essentially that the forms and processes of interaction that are found in the management of construction site work are symptomatic of many of the types of conditions found within a matrix setting. Furthermore, that the system of organisation that is established for the management of construction project work, supplies a framework for the occurrence of a matrix system of roles and relationships: in varying forms, and to varying degrees of formality. The research evidence on the forms and processes of interaction involved with respect to the actual operation of a matrix system of management is somewhat scant and inconclusive. The question is whether such necessary conditions are sufficient for a depiction of the actual processes of construction project management within a matrix framework. The general proposition put forward in this study is that they are. The empirical questions, to be explored in the later case descriptions and analyses are: how is this manifested, to what extent, in what forms, and with what implications? A similar set of questions are also inherent in the next section, which shifts the focus of attention now to the interorganisational network of relationships in the organisation and management of construction project activity.

3.5 Interorganisational Matrices

The situation described in the previous section relates only to the position and role of the individual (construction) firm involved in the network of interorganisational relationships that constitutes the 'temporary multi-organisation' (Cherns and Bryant 1984) that is established to undertake and manage construction taskwork. The picture is complicated immensely once this wider inter-organisational framework is taken into account. The diagrams given in Figure 3.2 illustrate two sets of types of contractual and management system that may be found in construction: differentiated according to whether project design activities are undertaken in house or via the employment, by the client, of independent consultants. Again it should be noted that these diagrams only depict two possibilities. A multitude of variants are possible, given the particular configuration of internal and external relationships for any given project. Also the potential complexity in the configuration of formal and informal relationships within the 'project organisation' has been simplified for the purposes of presentation. The main general point to be made here is that at a broader, interorganisational level of analysis within the project organisation as a whole, there is also the potential for the occurrence of an (implicit) matrix system of roles and relationships given the multiple influence patterns that are observable amongst the organisations' operational units, and each units' relationship with their broader organisation.

Before turning to the dynamics of the management process that

Figure 3.2 Interorganisational Matrices of Roles and Relationships

(a) With the use of external design consultants:

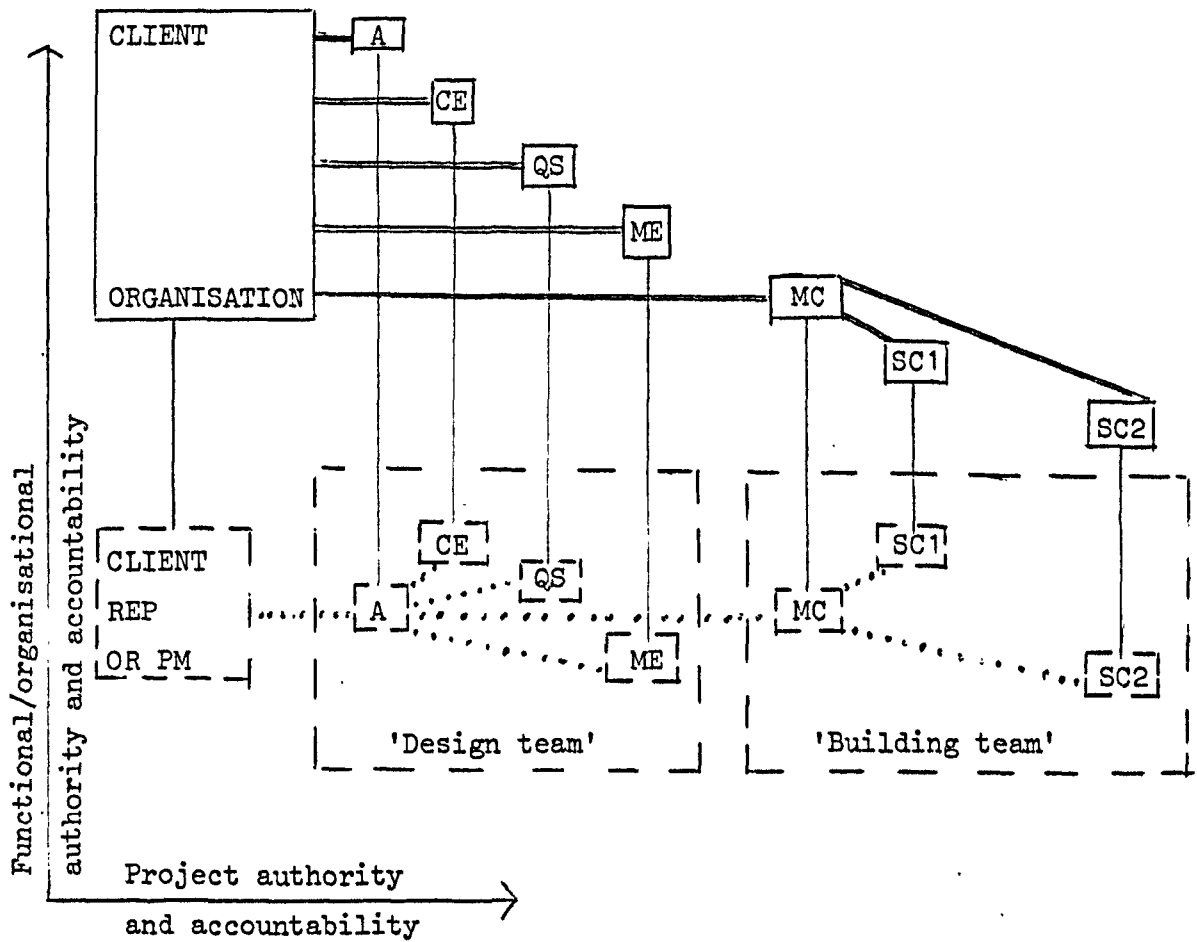

- KEY:
- A = Architect
 - CE = Civil/Structural Engineer
 - QS = Quantity Surveyor
 - ME = Mechanical/Electrical Engineer
 - = Organisation/Functional Department
 - = Agent or Task Group Representative
 - = Contractual Relationship
 - = Internal Line Management Relationship
 - = Project Chain of Command

Figure .2 Interorganisational Matrices of Roles and Relationships

(b) With the use of in-house design consultants:

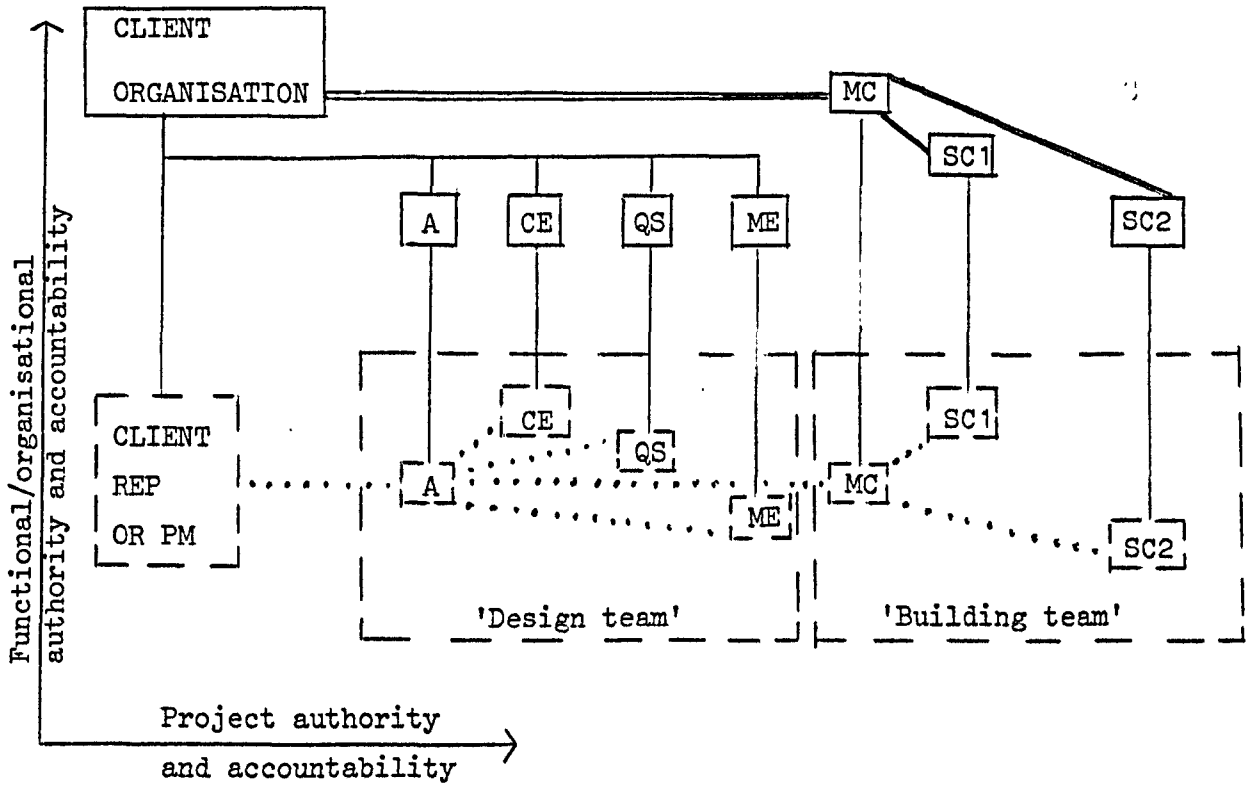

- KEY:
- A = Architect
 - CE = Civil/Structural Engineer
 - QS = Quantity Surveyor
 - ME = Mechanical/Electrical Engineer
 - = Organisation/Functional Department
 - = Agent or Task Group Representative
 - = Contractual Relationship
 - = Internal Line Management Relationship
 - = Project Chain of Command

allow for this prediction (especially, the relationship between design and construction processes), a brief series of points needs to be made in relation to the phenomenon of subcontracting in this respect.

There are a variety of forms of subcontracting that occur within the industry. At the level of the range of operations performed on site, subcontractors may be employed on a labour-only basis, on a labour and plant or materials basis, or as a self-contained unit operating on a supply and fix basis.¹⁵ The general economic, technological and other reasons for the decision as to whether to subcontract work or not in relation to a specific project are beyond the scope of this discussion. The important factor here is that subcontracting represents a degree of 'vertical disintegration' in the main construction firm's operations on site. The strategy may be one generally adopted by the firm, or contingent upon specific project and local conditions.¹⁶ However, to the extent that it occurs it involves the substitution of a hierarchical system of control for a market-based system of control based upon the establishment of a contractual set of terms and conditions (Ouchi 1979, Williamson 1975). At the same time, however, the physical proximity and interdependencies between the processes of work involved - described in the previous section - mark the need for a framework and processes of managerial interaction that allow for the complexities and interdependencies in the work processes involved in order to achieve a sufficient degree of co-ordination and control of work on site. If, because of these factors, a more decentralised system of management in the (main) construction organisation is matched with a more decentralised system within each of the subcontracting

organisations involved, then the conditions exist for studying the processes involved within a matrix framework. In this model, the relevant dual axes, and sources of authority, influence and control, become: on the one hand, that associated with the extra-organisational management of project task work; on the other hand, that associated with the relationships between the operational units and their wider organisations. In other words, the subcontractor's representative, agent or team, is responsible to the representatives of the main contracting organisation who are managing work on site on behalf of the firm to whom the subcontractor is under contract. At the same time they are also responsible to their own firm for the pursuance of organisational goals with respect to the project. The distinctiveness in the basis of this relationship and possible implications for the form and basis of interaction *will* be discussed below in Chapter 4. The point here is that such a framework, given the nature of the task, is apparent in the system of relationships that managing construction project task work involves. (It should also be noted that a comparable framework exists in the configuration of relationships amongst the design team and their position vis-a-vis the client. Here, however, it is rather the degree of 'horizontal (dis)integration' of design disciplines that is the appropriate split. Figure 3.2 has been subdivided in order to show the different pattern that in house and consultant relationships have in this respect. The difference is analogous to the difference between the main construction firm performing the work directly and hiring subcontractors. In both settings (construction and design), and in both configurations

(internal and external) a matrix framework occurs. The difference in the former respect is in the different basis of (dis)integration and specialisation in functions. The difference in the latter respect is in the different basis of the relationship (hierarchical or market) between groupings).

A further compounding factor in the administrative complexity that this suggests stems from the existence of 'nominations' for the performance of subcontract work. Formal nominations (and less formal mechanisms such as the appointment of 'approved' or 'preferred' subcontractors and/or suppliers) occur when a particular subcontractor is specified by the client or their agents. Most usually the type of work will be specialist in nature reflecting the premium placed upon the more direct control by the client and design team of the design quality of the work involved. 'Nominations' are distinct from the employment of the main contractor's own 'domestic' subcontractors, and are employed in the industry under a distinct form of contract.¹⁷ In terms of the management process that is involved, the employment of nominated subcontractors represents in practice a more extensive degree of involvement of design staff (the client's agents) in the design, manufacture and assembly of component products or units. What this means for the matrix framework described above, is a somewhat more complex potential pattern of authority, influence and control of subcontracted work by virtue of the additional processes of interaction with respect to the design that this implies. In other words, not only is the subcontractor subject to the dual pattern of influence with respect to their own organisation and the main contractor, but also to a tripartite system of influence and control due to the inclusion

of direct relationships with members of the design team. In practice, of course, the conditions will vary, contingent upon the circumstances faced. In one respect this may mean that the main contractor de facto plays a much more direct role in mediating designer-subcontractor patterns of interaction. Conversely, however, such patterns of interaction may extend de facto to the management of the main contractor's own 'domestic' subcontractors' operations. These are largely empirical questions. The general point here is that the potentiality for close and continuing interaction with respect to the design details involved lends a further complicating dimension to the model of interorganisational matrix management proposed.

3.6 Interdependence between Design and Construction Processes

The foregoing discussion has been based implicitly upon the assumption of a degree of reciprocal interdependence (continuing into the construction process on site) between design and construction activities. Indeed, a high and continuing level of such interdependence between these activities (across the range of work undertaken on site) has proved a central feature in investigations of the problems of management of the construction process as a whole (Higgin and Jessop 1965, Crichton 1966, Morris 1972, 1973). There are two issues that deserve attention here. The first concerns problems of co-ordination and control between design and construction activity. The second concerns these problems in the context of organisational differentiation. To deal briefly with the first point, the nature of the task undertaken in construction is one in which the 'technical system' requirements are for a pattern of interaction in which communication patterns are requisitely more informal (Higgin and Jessop 1965) and the relationship between

design and construction phases recognises the need for 'feedback loops' (Crichton 1966), and more informal mechanisms of control (ibid, p46). However, since early reports concerning the problems of management in the construction industry (Emmerson 1962, Banwell 1964), attention has been directed towards the inherent conflict between these 'technical system' requirements and the nature of the institutional framework for linking design and construction processes - based as it is upon a system of tendering and contractual relationships amongst the parties involved. The focus has been upon the disjuncture at the "interface" (Morris 1972) between design and construction processes, and its inconsistency with the need for a more flexible and informal arrangement to complement the interdependencies in the technical processes involved. Thus, attention has been directed towards the 'sequential finality' implicit in the institutional framework, in which phases and responsibilities are separated and differential and inconsistent control mechanisms are employed (Crichton 1966). The problematic is manifested in the tendency for construction firms to have a limited degree of involvement in design processes despite the presumed efficacy of this; problems in introducing engineering design changes and in reaching agreement on design changes once the contract has been signed; and the problems of coordination that occur to the extent that there is a significant degree of 'overlap' between design and construction stages of the project. It is noted that, in practice, there is a tendency for more informal and flexible patterns of interaction to occur (Higgin and Jessop 1965, Crichton 1966). For example:

"... in practice, reality forces a recognition of interdependence, uncertainty, phased decision-making and continuous application of functions. It forces members of the building team to adapt themselves."

(Crichton 1966, p46)

However, these pragmatic tendencies are seen as being generally 'overpowered' by the formal system of interaction in which contractual documents - and the bill of quantities in particular - provide a mechanism for control and a general framework for interaction which is regarded as inconsistent with the processual (rather than product) dynamics of the task (Higgin and Jessop 1965). According to Morris (1972, pp8-9) there is fostered a "hierarchic" as opposed to "transformational" viewpoint of the performance of construction task work. The tension between these tendencies is made explicit in many commentaries on the management of large projects (eg Halsey and Margerison 1978, pp249-251). The implications of this for the forms and processes of interaction in the construction setting will be discussed in greater detail in Chapter 4. The main point to be emphasised at the moment is that, in the relationship between design and construction processes, there is generally held to be a mismatch between the technical uncertainties and interdependencies in the processes involved and the imposition of a formal contractual system that assumes a degree of certainty, finality and independence of the processes involved. The key element in this mismatch is the organisational independence of resource controllers involved in the total process of design and construction (Higgin and Jessop 1965; Morris 1972, 1973).

Referring this back to the earlier description of the matrix framework for interaction, what is of particular interest are the implications of organisational differentiation with respect to design and construction activities across this contractual divide, and associated

patterns of integration. These issues will be discussed in more detail in Chapter 4. However, it is worthwhile to note specific possibilities identified in the construction management literature. Morris (1972, p31) in particular addresses the tendencies towards differentiation (Lawrence and Lorsch 1967) at an organisational level, related to differences in the 'character' of the interacting organisations. Specifically he notes potential general variability between design and construction organisations in their size (contractors being larger in scale); their structural attributes (division of labour, levels of management, administrative ratio, etc); their complexity (levels of specialisation and professionalisation); their performance criteria (eg quality or cost); and, generally speaking, relative tendencies towards a more 'organic' as opposed to 'mechanistic' framework of interaction (he suggests that design firms will exhibit greater tendencies towards the latter). Unfortunately, his analysis of the results does not clearly and systematically disaggregate these facets of the organisations' attributes in relating organisational differentiation with the processes and levels of integration achieved at the 'design-construct interface'. However, one would expect such factors and their implications to be of some interest in the investigation of project management in this type of interorganisational setting, given the broader 'cultural' inconsistencies that they tend to imply.

3.7 Alternative Delivery Systems

A more general set of observations can be made with respect to the level of integration achieved if one looks more broadly at the form of contractual relationship or 'delivery system' under which the various parties are contracted by the client to perform and

manage project task work. The earlier discussion has tended to assume the occurrence of a 'traditional' set of contractual relationships, in which design and construction organisations are hired separately by the client to undertake the work: the former, as well as providing the design, supervising and controlling the process of construction on site on behalf of the client organisation.¹⁸ However, in recent years, attention has been directed towards alternative frameworks for project organisation and management: specifically, management contracting and design and construct contracting. In the former case, a main managing contractor is employed specifically to manage the process of construction, undertaking none of the work directly and is paid a fee in much the same way as design consultants are (see, for instance, Thomas 1975, Carter 1972).

In the latter case, a construction firm is employed to supply a 'package deal' - involving the design of the product as well as its construction.

The historical development of these forms is described by Higgin and Jessop (1965) in their discussion of the development of the professions and builders' organisations at a societal level.¹⁹ The point to be raised here, is that such arrangements are ostensibly geared towards accommodating the complexities, uncertainties and interdependencies involved in the relationship between design and construction activities (and on site in the relationship between interdependent construction processes). In the case of management contracting, this is reflected in the specialisation of the firm in planning, co-ordinating and controlling work itself and in acting as a conduit for the two-way flow of design and construction information between designer and

subcontractor. In the case of design and construct 'package deals', the process of design-construct interaction is internalised within the firm performing both functions. Both systems involve a much earlier degree of involvement of the construction organisation in the design process than tends to be the case in a more 'traditional' system. Further, it has been noted that the 'management system' for the performance of taskwork is, in these cases, more fully consistent with the 'contractual system' of roles and relationships that link the parties than is the case in a more 'traditional' setting (Institute of Building, 1979). It is not the intention here to address the quite sizeable body of construction management literature that, usually drawing upon descriptions of specific instances in which these systems have been employed, categorises the applicability of these systems to the scale and type of work involved, their advantages and disadvantages with respect to achieving cost, time and quality objectives, and the problems or otherwise in their implementation and operation.²⁰ Rather the intention here is to make the general point that such mechanisms aim in part to achieve the degree of co-ordination and control of construction work that is confounded by the organisational separation of design and construction processes.²¹ Whether they achieve this aim (and at what costs) is the subject of debate within the industry. For the purposes of this discussion, whether or not they achieve a sufficient level of integration in the sense of the word as defined by Lawrence and Lorsch (1967) is an empirical question. One might expect, for example, that each professional group's investment in their position and role within the construction management process, might militate against the favourable review

of such forms by certain groups, and promote their exaltation by others. Put more simply, architects, for instance, may feel that such forms mean that contractors are 'stealing the show'. The broad issue here is the effects on a 'role culture' within the industry (Higgin and Jessop 1965) in which the position, role and jurisdiction of professional and occupational groups with respect to project management is a highly developed and salient feature. In relation to specific projects, the questions arise as to what impact such forms have upon achieving the level of integration required, in what ways, in what respects, and with what consequences? In part this may be influenced by the sets of perceptions, assumptions and attitudes mentioned above. More specifically, it will be influenced by particularistic characteristics of the work involved, the management of the processes involved, and the constellation or pattern of roles and relationships within the 'local' network of interaction between those organisations and their subgroups involved.

What is clear however, is that with respect to the matrix framework for interaction described earlier, this variability in the nature of the contractual system employed, represents variability in the explicit mechanisms employed to co-ordinate activity and to integrate subunits performing interdependent work. In other words, the empirical possibility is of the employment of an explicit and central integrative mechanism in the network of interorganisational roles and relationships in the event of the establishment of a 'non traditional' contractual system for the performance of project work. In the case of a design and construct contract, this mechanism will be internal to the firm undertaking both design and construction activities. In the case of a management contract, the mechanism will

be external to the firms undertaking the activities. In both cases an individual Project Manager or Project Management team may be involved in coordinating activity undertaken by functional specialists. The difference will be in the relative organisational location of the respective participants. The system of management contracting or, to give it a more generic term, 'Project Management' in particular has received a considerable amount of attention in the construction management literature, as a mechanism whereby design and construction processes are more closely coordinated. The development of this system has been most extensive in the United States as has the discussion of its rationale and implications (eg Adrian 1981, Clough and Sears 1979, Barrie and Paulson 1978). Referred to as "(Professional) Construction Management", the emphasis is upon a processual view of construction project activity as a whole:

"(Construction Management) is a process by which a potential project owner engages an agent, referred to as the CM, or Construction Manager, to co-ordinate and communicate the entire project process, including project feasibility, design, planning, letting, construction and project implementation, with the objective of minimising the project time and cost, and maintaining the project quality.

(Adrian 1981, p2; emphasis in original)

A similar emphasis upon co-ordination and integration of design and construction processes is found in discussions of its application to the management of project activity in the UK (Ireland and Stretton 1981, Failes 1977, Institute of Building 1979):

"By comparison with other methods in which the design and management roles are simultaneously taken by one person, or in which the management responsibility is

passed from one functional group to another during the project, the Project Management method provides an integrated approach."

(Ireland and Stretton 1981, p68)

The method is linked to the intensive need for co-ordinating the activities of various trades, specialisms and disciplines towards the achievement of a common set of project objectives, where there is complexity in the processes involved, a lack of time for planning and the need for cross-cutting 'teamwork' (eg Failes 1977). The mechanism consists of the appointment of an agent independent of those with prime responsibility for undertaking design and construction activities (in a traditional contracting system, it is a design specialist - architect or engineer - who has traditionally performed this 'project management function'). The independence of this agency (or team) is the feature that marks out the distinctiveness of the management contracting form from both the more 'traditional' arrangement, and the design and construction alternative. Given the discussion in the latter part of Chapter 2 above, it is this facet in particular, and its implications for the role of the integrator in a matrix system, that is of particular interest to this study.

3.8 Summary

This chapter has sought to relate the discussion in the previous two chapters to the situation and circumstances found in the construction industry. Attention has been focused upon the characteristics of the task performed in construction, and the implications of its distinctive features have been addressed in terms of the forms of organisation and processes of management found at both an intra-

and inter-organisational level of analysis within the industry. In particular the occurrence of a matrix-type framework for interaction in the management of construction project taskwork at both levels of analysis has been postulated. Bearing this situation in mind, the discussion in the next chapter turns to a consideration of likely patterns and processes of interaction in the interorganisational management of the project. The discussion will return to and explore more fully some of the issues raised towards the end of Chapter 2, but in the context of the more specific characteristics of the process of management with respect to construction project task work that have been highlighted in this chapter. Following this commentary, the themes that have been discussed will be drawn together and presented as a model of the processes of construction project management, from which a number of hypotheses will be drawn and presented.

Footnotes

- 1 See, for instance, the articles by Bissett, Hollenbach, Duke et al in "Realities in Project Management" (Proceedings of Project Management Institute (USA), Chicago, Illinois, 1977).
- 2 Excepting here the possibility of the need to perform remedial and/or maintenance work during the buildings' commissioning and use.
- 3 An exception to this rule in the latter respect may be found in the conditions in the shipbuilding industry. In shipbuilding, spatial and geophysical conditions may also play a similar part in conditioning and influencing in practice the production system employed. The slight difference here is that shipbuilding is not necessarily a location-specific production activity (although the size of the product tends in practice to mean that this is so). A more important practical difference is that access to water and launch facilities is the major prerequisite. Consequently, the firm's activities are not geographically dispersed, but concentrated round, for example, one locality in which deep water harbour facilities are available.
- 4 See, for instance, Braverman (1974). It is beyond the scope of this thesis to discuss in any great detail characteristics of the labour process in construction, and the relationship between production technology and levels of skill. For a fuller discussion, see, for instance, papers by A. Tuckman and J. Paulding in Bartlett (1980), Proceedings, pp. 54-63.
- 5 They also have implications for the structure of the industry at a more macrolevel. In particular, the implications for lowering barriers to entry to small firms within the industry: through reduced economies of scale; ability to specialise by process not product (meaning extensive vertical disintegration); and the low fixed capital outlay required to set up in business. Such factors have meant the continued existence of a large number of small, specialised firms, and no significant historical trend towards higher levels of concentration. For a fuller discussion, see Fleming (1980), Thompson (1981).
- 6 Although in the latter respect, differentiating between broad stages - eg main construction and remedial/maintenance work - does suggest this possibility. However, here one is strictly dealing with different processes that happen to correspond (although not necessarily) with distinct chronological stages.

- 7 As will be described in Chapter 6, the main contractor employed on that project owned and operated its own piling division. Much of that division's activity was in undertaking subcontract work for main contractors on other projects. It should be noted that this example, coupled with others (eg the main managing contractor in Chapter 10) suggests a further basis for specialisation: namely in the specific form of contractual or delivery system employed. The two examples noted here serve as illustrations of specialising as a subcontractor, and as a management contractor, respectively. The former is somewhat different in that the limited scope of the work undertaken with respect to the specific construction process meant that, by definition, the division could only undertake subcontracted work (including for its own parent organisation). The latter is perhaps more interesting. In the course of the research it was noted that a number of large construction organisations competing in the industry now operated specialist divisions that undertook only management and/or design and construct contracts. These forms are returned to in more detail below.
- 8 The situation facing firms engaged in the provision of professional design services is clearly different here. Namely, the orientation of each specific discipline (architecture, civil/structural engineering, mechanical/electrical services engineering, and surveying) is to specific processes across the design and construction 'cycle'. Consequently, specialisation by process in this respect is a more pertinent characteristic.
- 9 A more general problem emerges in the financing of project work, which involves, initially, large outlays for variable capital for which remuneration is obtained only after the work involved at interim stages. For a fuller discussion of the implications, see Fleming (1980).
- 10 The degree of 'casualism' in employment patterns and recruitment within the industry that this situation engenders has been the subject to a good deal of attention. (Phelps-Brown 1968, NEDO 1970, EIU 1978). It is not the intention here to delve further into the issue of labour recruitment, other than to note the extent to which, in recent years, subcontracting has developed as a mechanism employed by main contracting organisations to offset their dependency upon fluctuating and uncertain product and labour market conditions (eg Bresnen et al 1985).
- 11 For a discussion of the implications of organisational transience in temporary systems, see Bryman et al (1986).
- 12 A corresponding source of uncertainty for the design firm is in the nature of the original client's brief, and any subsequent ambiguities that emerge from that brief, or changes that occur to it as the process of design (and then construction) is undertaken.

- 13 For a review and critique of this literature with respect to the forms and processes of leadership exercised on site, see Bresnen et al (1984).
- 14 Here it is worthwhile to point to one question that this distinction raises. Specifically, if task conditions on site suggest the efficacy of a much 'looser' organic model of interaction, then to what extent, and how, does this situation dovetail with the aim of devising a set of more precise mechanisms for planning and project control which amount to a more 'mechanistic' aid to project management? For example, what are the implications of devising a mechanism for the assessment of performance based upon precisely and unambiguously defined evaluation criteria, when for performance to be effectively achieved, those criteria themselves are not necessarily unambiguous. The issue will be, to some extent, returned to later (Chapter 4) in a discussion of the juxtaposition between technical system and business system requirements (Sayles and Chandler 1971). At the moment it is worthwhile to point out that the massive attention directed towards devising more suitable and effective informational systems for project planning and control reflects this contradiction between the need for an essentially static and certain mechanism in conditions in which change and uncertainty are the norms.
- 15 An additional possibility, returned to below, is that of client/design team "nomination".
- 16 A similar line of argument here is applicable to the contracting of materials suppliers and plant hire firms to provide materials and plant respectively for the performance of work on site by the main contracting organisation.
- 17 Employment is via, respectively, the 'green' and 'blue' forms of standard subcontract issued by the Joint Contracts Tribunal.
- 18 In both building and civil engineering, standard forms of contract, published by the Joint Contracts Tribunal and the Institute of Civil Engineers respectively, provide the framework for this triadic system of roles and relationships (see Walker, Smith and Close (1971)).
- 19 It should also be noted that additional, but less pervasive in large scale and idiosyncratic construction settings, mechanisms have emerged: notably, the use of serial contracts for 'rolling' developments and, in certain instances, the direct management of wholly-subcontracted work by professional design staff (ie architects).

- 20 See. for instance, McLaughlin (1981, pp321-330), for a discussion of the advantages and disadvantages of these forms from the viewpoint of the client; and the factors that are likely to influence the efficacy of one form or another in this respect. See also the reports by Wood (1975) and Wilson (1974) which pertain to the strategic choices available to the client in the public and private sectors of the industry respectively.
- 21 Interestingly, if one takes the individual organisation in interaction as the focal unit of analysis, such mechanisms may be interpreted as being strategies adopted by the firm (ie the contractor) to lessen their dependency upon the environment by seeking to control key functions (ie design). In the case of design and construct, by expanding their 'domain' to include these activities; in the case of management contracting, by changing their 'domain' and specialising in the actual co-ordination and control of design and construction processes. Aldrich (1979) has noted that firms in an interorganisational network may resolve disputes by expanding or contracting their boundaries. It seems pertinent to suggest that, at a broader level, firms may seek to control their environment by pursuing comparable strategies involving changing their 'domain' (Levine and White 1960, Thompson 1967).

CHAPTER FOUR

INTERORGANISATIONAL PROJECT MANAGEMENT IN CONSTRUCTION:

Chapter 2 addressed the issue of the power-dependence relationship between organisations and potential implications for the form and processes of interaction at the operational level in the joint management of project work. In the light of the discussion in Chapter 3, the intention here is to address the issue further by focusing more particularly upon the nature of the business relationship linking the parties and its relevance to an understanding of the achievement of a level of integration between the parties concerned. In doing so, attention will be directed towards the formal structure of interaction as it is defined by, and in turn may define, the broader power relationship between the parties. The form of agreement entered into will be looked at with respect to its role in defining and delineating the formal structures and processes of interaction between the parties involved, and how this may correspond to the 'technical system' requirements of the task being performed.

4.1 The Contractual Relationship: The Formal Basis for
Interaction

The use of a contract corresponds to the establishment of a formalised agreement between the parties involved (Marrett 1971) which is legally and contractually binding (Van de Ven and Ferry 1980, Aldrich 1979). The contractual system of interest in this study is the set of legally-enforceable terms and conditions of contract that form the basis for case law in the construction industry (eg Porter 1980). A more detailed exposition of the roles and responsibilities of the parties under these various forms of agreement can be found in Porter (1980) or Walker, Smith and Close (1971). At the moment, it is useful to assess the general properties of the type of agreement reached in a construction project setting. Firstly, it is important

to distinguish between the terms and conditions of the contract as they apply to the specific project concerned, as opposed to the more generalised rights and obligations of parties under a contract. The former encompass details which are project specific. These will include the substantive content of the agreement (ie time, cost and quality objectives, specification of levels and types of resources to be used, production techniques, etc), as well as procedural mechanisms established for the planning, monitoring and co-ordination of work (eg monthly review meetings, the procedures for the approval of drawings and programmes, etc). The latter relate to the legal rights and obligations of the parties conferred under general terms and conditions of contract (eg rights to compensation, remuneration, etc). The legal framework which encompasses this latter set of general terms and conditions of contract corresponds quite closely to a 'mandated' framework for interaction (Hall et al 1977),¹ wherein the roles, rights and obligations of the parties under law are specified, their enactment being contingent upon substantive and procedural features of the project and circumstances as they occur and develop. As such, general terms and conditions serve to define the parameters to the legitimacy of action of one party with respect to the other, and the nature and extent of sanctions applicable in the case of default. The argument that is pursued here is that, in doing so, they function as a proxy for internal, bureaucratic mechanisms of control exercised within organisations, in the sense that they define formal patterns of authority and accountability in the relationships between participating organisations. The formal authority of one party (and, conversely, the others' responsibility) is given legitimacy in a structural framework for interaction devised at a broader,

'institutional' level within the industry (Parsons 1960). The availability of formal sanctions and a system of arbitration in the case of default by one or other of the parties means that the framework also constitutes a judicial or appeals system for the resolution of disputes (Brown 1966; Simon 1960, pp11-12). Schlacher (1979) has described this system as the "constitution" of the construction project organisation.

Before continuing further, it is useful to address briefly certain aspects of the form of the relationship as it is conditioned by a broader framework agreed or negotiated at an institutional level. It is beyond the scope of this thesis to attempt to provide a broad overview of patterns of interaction at an institutional level with respect to the establishment of construction contracts, or to attempt to chart changes in general terms and conditions over time and the dynamics of the processes involved.² However, what is pertinent to this discussion is that current terms and conditions of contract reflect the outcome of broader processes of agreement or negotiation concerned with defining the respective rights and obligations of the parties engaged in a demand-supply transaction. As such, and given that some degree of legitimate goal conflict is inherent in the nature of a demand-supply transaction (Litwak and Hylton 1962, Warren 1967, Turk 1973), then one would expect that the weights attached to the legitimacy of the respective parties would in some way be related to the locus of power at an institutional level and the degree of representation available, through collective action, to the interests involved. In other words, that the establishment of a legal framework for interaction follows from a negotiating/ bargaining process, rather than from a process in which consensus fully exists. The recent debate centring upon the introduction of new standard terms and conditions of contract within the industry

serves perhaps as a timely illustration of the process of change in the formal legal framework for interaction, and how change in this respect is manifested in a new 'balance of power' among the interests represented.³ The point to be made here is simply that the formal agreement embodies the institutionalisation of legitimate but conflicting interests; in doing so, it may represent, in part, conditions of demand and supply at a broader societal level which, moreover, are not necessarily static and which may be amended or adjusted historically.⁴

Turning again to what this type of system means for the parties engaged in a specific transaction, it should be clear that some degree of legal specification of formal rights and obligations exists to guide interaction. Such a situation - of a highly developed (albeit subject to change) system of formal, legal specification of rights and obligations - perhaps contrasts somewhat with the types of situation commonly investigated in other interorganisational settings. Early interorganisational analysts tended to stress the study of interactive behaviour under conditions of unstructured authority. For example, in their study of co-ordinating agencies in community chest and social services exchanges, Litwak and Hylton (1962) suggested that:

"... most intraorganisational analysis is made under the assumption of a fairly well-defined authority structure. As a consequence, formal authority plays a larger role in explaining behaviour within organisations than it does in interorganisational analysis."

(ibid, p341)

This is undoubtedly the case, given the specific types of network

(eg community and public services networks) that have most commonly been researched in the field. Later models, turning their attention to 'mandated' frameworks for interaction (Hall et al 1977, Raelin 1980) have provided a means whereby formal relationships that play a significant part may be more fully incorporated. However, such models have tended to diverge considerably from the emphasis upon economic exchange which is the basis for interaction in the type of setting discussed here. More generally, the point has been made that contractual relationships and other forms of external interaction common in a business and industrial setting have seldom been the focus of attention for interorganisational analysts (Reve and Stern 1979).⁵

The point raised here is that the formal contractual structure of interaction constitutes a form of "executive system" (Brown 1966) that acts as a proxy for internal structures of power, authority and control since it is concerned with specifying the legitimacy of action (and hence, legitimate power - French and Raven 1959) of the parties and their rights to exercise sanctions with respect to the performance of project work. As such it plays an important part in defining the parameters for interaction, and may be critical to an understanding of the processes involved. The first point about the contract framework for interaction is that it is implicitly hierarchical in nature. That is, the roles, rights and obligations of each party under the contract reflect their position in the demand-supply chain of relationships. In other words: clients supply a brief for designers to design to; manufacturers build to the designers' specifications; and suppliers supply work or components to the detailed specifications and schedules of work articulated by

the manufacturer and based on the original brief and specification. As was noted in an earlier quotation, the contractual relationships that link the parties at each level are control-oriented (Sayles and Chandler op cit). The contractual terms and conditions reflect this directionality: the party on the demand side is vested with the right to obtain the levels of performance required as specified in the details of the original agreement; the party on the supply side is vested with the right to remuneration for the performance of that work, and for compensation stemming from any changes to it or any misdirections in the original remit. The problem of securing accountability in this respect, of course, stems from ambiguities and so on in the interpretation of the original details or of the performance levels required: this will be returned to below. The point here is that, while the transaction is one of exchange (Homans 1958), it is a peculiaristic form of exchange, in that the level and intensity of managerial interaction is high (eg in the two-way flow of design and production information between the parties). Unlike in a more straightforward form of exchange relationship, the general conditions of contract need to account for this feature: they do so by supplying a legalistic framework that is quasi-hierarchical in nature. Another way of looking at this is to recognise that the chain of relationships described above corresponds to a situation of "vertical disintegration": rather than one organisation performing all these functions (ie design, manufacture, supply), they are undertaken by separate organisations linked in a market relationship - each party's outputs forming part of the inputs of the next down the chain. Given this level of interdependence, the contractual mechanism serves not simply to specify terms and conditions of exchange, but also to provide a

framework for the performance of planning, co-ordination and control functions with respect to the management of project work.

A critical feature of this formal structure of interaction is the extent to which it defines the right to exercise discretion and what this means for the locus of formal influence within the interorganisational network. From a cursory glance at sets of contractual terms and conditions used in construction, there are sufficient examples of the phrases "where in the opinion of ..." and "to the satisfaction of ..." and the like, to suggest that this discretionary component is of significant importance.⁶ For example, assuming the quality of a supplied product is not fully as specified. The designer then has the right both to decide whether to accept or reject the product, and then to act according to the procedural mechanisms available (eg to inform the supplier to replace the product within a specified time period). Of course, a multitude of factors may influence the decision (eg the benefits of rework against the costs of disruption if the problem is minor). However, the main point is simply that, in a great many instances, that discretionary authority is available. In other words, like internal structures of authority that constitute the organisations' 'executive system' (Brown 1966), contractual structures of authority in the form of those investigated here describe the formal authority available to participants - both to act and to decide (Koontz and O'Donnell 1980). The difference here perhaps lies in the notion of the legitimacy of action - particularly in the exercise of discretion available to participants - on the basis of this contractual authority. French and Raven (1959) describe legitimate power as:

"... that power which stems from internalised values in P which dictate that O has a legitimate right to influence P and that P has an obligation to accept this influence ... the notion of legitimacy involves some sort of code or standard, accepted by the individual by virtue of which the external agent can assert his power."

(ibid, p265; emphasis added)

The question one has to ask in an interorganisational setting is to what extent the general terms and conditions of contract embody values which are shared amongst the participants. In other words, to what extent the utilitarian, as opposed to normative, basis of the relationship (Etzioni 1965) promotes differential perceptions of the legitimacy of particular forms of action - particularly the manner in which discretionary authority is exercised. On the one hand, one might expect some degree of 'unity of purpose' (Simon 1965) directed towards the achievement of a common set of project objectives would tend to widen one party's "zone of acceptance" (ibid) to influence attempts made by the other on the basis of their contractual authority. However, one might also find that differential values, norms and goals may play some part in defining the party's "zone of acceptance" of influence attempts made on this basis.

The general point to be made here is that the establishment of a contractual framework for delineating the respective rights and obligations of the parties involved acts in many ways as a quasi-administrative framework for interaction in the joint construction and management of a building project. The arrangement is neither a pure market transaction, nor a pure administrative arrangement (Ouchi 1980): it combines elements of both.

The issues just described serve as an important structural backdrop for the following discussion of the nature of processes of interaction between the parties involved jointly in the management of a construction project. In particular, it should be borne in mind that the legal framework sets the limits to action by providing the opportunity to take recourse to formal mechanisms to secure compliance (although the associated costs and disadvantages may practically constrain the choice of options here: eg the costs of litigation); also, however, that the possibilities for more 'informal' processes of interactive decision-making may be extended by virtue of the discretion available to participants. On the latter point, the formal authority to take decisions may enhance the power in interaction of one party relative to the other. On the other hand, to the extent that the other party has other means of influence at their disposal (eg economic power), then in an ambiguous situation, the exercise of discretionary authority may in effect allow access to the other party to influence that decision. In other words, depending on circumstances, the scope available to exercise discretionary authority may become transformed into the scope available to other parties to influence - through persuasion, cajoling or negotiation - the decision taken.

Returning to the project-specific content of the agreement, and in particular its substantive content, there are a number of points to be raised here. The first is that the specific terms of the agreement (ie the quality and quantity of work expected for an

agreed price) may reflect to some extent the respective (economic) power of the participating organisations. In the case of a competitive tendering process that led to the reaching of an agreement, the price/output formula may be a reflection of general economic conditions within the industry as a whole (ie whether it is a buyer's or seller's market). However, it may also be possible that more 'localised' environmental conditions play an important part (Kochan 1975, p438). For instance, the heavy dependence of a contractor upon one major client as a source of work in generally unfavourable economic conditions may influence downwards the price submitted to undertake the work. Where a negotiated process precedes the reaching of an agreement, such 'localised' economic factors are clearly likely to become more salient to the process and possibly influence the terms finally reached. There are, of course, a multitude of possibilities, and the aim is not here to examine fully the range of possibilities. Rather it is to suggest simply that such antecedent conditions may have an important bearing upon subsequent processes of interaction. As Sayles and Chandler (1971) have noted: initially in negotiating contracts, each party is concerned with driving a hard bargain. The formation of the transaction places the parties in basically conflicting positions. The business agreement reached is by definition competitive rather than cooperative, and the adversarial nature of the relationship is inherent. This is not to suggest that conflict, competition and so on necessarily emerge subsequently in the relationship. In many instances it may not be the case that such 'latent conflict' (Pondy 1967) exists, if both parties feel they have not been disadvantaged in the process of reaching an agreement. In other words, it is not necessarily a zero-sum or win-lose situation (Von Neumann and Morgenstern 1944). Furthermore,

any such latent conflict in this respect may not be converted into 'overt' conflict (Pondy 1967). The extent to which such circumstances occur or not is clearly an empirical question, and one which may depend upon a variety of conditions. Indeed, interorganisational and collective bargaining theorists stress the importance of separating latent conflicts of interest from overt conflicts in interaction. For instance:

"By distinguishing between interorganisational and intraorganisational analysis, the investigator is sensitised to the organisational correlates of value conflict and value consistency. Without such a distinction, he might concentrate instead on showing that value conflicts lead to organisational breakdown without appreciating that interorganisational relations permit and encourage conflict without destruction of the overall societal relation."

(Litwak and Hylton 1962, pp340-1)

A related point is made by Warren (1972), who takes a more detailed focus of analysis and who separates the conditions of the relationship as a whole, from those with respect to the resolution of specific issues within the context of that relationship:

"On any particular issue, any two organisations may have the same issue-outcome interest, or divergent issue-outcome interests. It is important to note that concerted decision-making may occur under situations of issue-outcome interest convergence or divergence. Where issue-outcome interests of two or more organisations converge, their concerted decision-making is likely to be characterised by co-operative processes in the decision-making itself, and in seeking to assure the mutually desired issue-outcome ... Where issue-outcome interests ... diverge, their concerted decision-making is likely to be characterised by contest processes in the decision-making itself, and in seeking to assure the mutually exclusive desired issue-outcomes."

(ibid, pp26-27)

The point here is that the very nature of the contractual relationship and the way in which an agreement has been reached manifested in its terms, may provide the basis for understanding the motivation to ensure the achievement of one's own desired outcome in subsequent interaction episodes. One would expect this to be particularly the case in circumstances in which the process of reaching agreement has been based upon overt or tacit attempts to obtain acquiescence or compliance based upon the explicit or implicit exercise of (economic) power. Subsequent conditions and developments may help or hinder the parties in furthering their advantage or redressing the balance. The stance taken with respect to specific issues may or may not be informed directly by experience in earlier processes of interaction. These possibilities clearly depend upon the empirical circumstances surrounding the nature and development of the particular relationship in question. However, it is important to note that the motivational basis underscoring interaction may be in part a consequence of the dynamics of the process that led to the establishment of that relationship in the first place.

The second point to be raised concerns the status of the agreement reached with respect to the scope available to the participants in exercising influence - through negotiation and bargaining strategies for instance - once the agreement is reached. The previous paragraph raised briefly the possibility that the process of reaching agreement may itself form the basis for an understanding of the motivation of the parties in subsequent interaction (with respect to achieving their goals). This point is concerned with addressing the extent to which the actual nature of the agreement allows them the opportunity or ability to realise their goals in interaction.

The complementarity of the motivation to pursue a set of goals and the ability to achieve them by being able to 'interfere' with others' goal attainment has been shown to be crucial to an understanding of bargaining and conflict in interorganisational settings (Schmidt and Kochan 1972, Kochan et al 1975). The point is of particular importance here because of the juxtaposition in the relationship between the business agreement reached and the complex and uncertain characteristics of the task being performed (Sayles and Chandler 1971). The key issue here is the degree of coverage and clarity in the original agreement with respect to the substantive content and procedural mechanisms established for the performance of work in a complex project setting.

Thompson (1967) has defined contracting as:

"the negotiation of an agreement for the exchange of performances in the future."

(ibid, p 35)

In a straightforward transaction of a product or service at a given price and specified (and easily monitored) quality, the 'performances' involved are likely to be subject to a minimum of uncertainty or ambiguity.⁷ However, in the type of setting discussed in this thesis, such an ability to define fully in advance the quantitative and qualitative parameters of the performances to be achieved is by no means as straightforward an exercise.⁸ Sayles and Chandler (1971) have devoted considerable attention to this phenomenon and its manifestation in the particularistic form taken by planning activity in conditions of task uncertainty and interdependence, and

where an interorganisational bargaining process forms the means of reaching a contractual agreement:

"In large scale redevelopment projects, a clear sequence of action is not possible because of their extended duration, the many technical unknowns, the changing balance of power among interest groups, the continual discovery of new 'facts' and constantly changing constraints and pressures."

(ibid, p 7)

They note that the planning process is a dynamic and iterative one. In substantive terms, it may involve some degree of uncertainty concerning the precise technical means to achieve objectives, for instance. Further, certain sections of the work may be dependent upon the outcome of earlier results; consequently, specific sub-objectives, and the resources and techniques needed to perform them, may be left unclear and subject to fuller specification and perhaps negotiation during the course of taskwork performance. In construction projects in the UK, 'provisional sums' are used to demarcate an area of work to be subsequently more fully specified as the project on site proceeds.

Secondly, dependent upon circumstances, the work being undertaken may change or be amended. In construction, design variations and the need to perform extra work - either as a consequence of factors emerging during the course of construction (eg ground conditions) or through client initiation (eg deciding to change the type of fittings to be installed) - are common enough phenomena.

An additional set of factors emerge to complicate the planning

process, when one considers the part played by other organisations in defining the content of the substantive agreement. Sayles and Chandler have noted, for instance, that planning as a process becomes much more dependent upon information generated during the course of negotiations (ibid, Ch 2). In construction contracting, of course, the price of the work ultimately depends upon the information supplied by contractors during the tendering or negotiation process. However, additional interorganisational interaction during the planning process may also be to some extent evident in the establishment of other performance criteria (notably, the quality specification: whether, for instance, a certain type of finishing can be achieved and, if so, at what cost and with what implications for the programme of works?) In other words, the plans drawn up for the work depend to some extent upon a two-way flow of design specification and construction planning information. (The same phenomenon may hold at other levels: eg the main contractor needing to adjust their plans to allow for suppliers' production lead times and their schedules of work with respect to the capacity available). What is particularistic about this type of setting is not only that the process of planning itself is a dynamic and iterative one, but also that it crosses the boundary between the organisations involved and may also correspond to a process of negotiation. In other words, not only are original plans an 'estimate' of what is required (using 'estimate' in the generic sense and not solely with respect to the price submitted); but also they constitute a 'negotiated estimate' of the work required, obtained through joint interaction to some degree in the planning process.

The point here is that, to the extent that this occurs, there

is a degree of 'reciprocal interdependence' in the planning process itself (as well as in subsequent interaction, including the replanning of work on site as conditions alter). Taking the relationship between design and construction activities in general, their conceptualisation as distinct sequentially-related phases in the project cycle as a whole contrasts with a reality in which the processes are more closely interlinked (Morris 1972). Moreover, to the extent that task uncertainty is a feature of the situation, one would expect this to be requisitely so. There is a paradox suggested here: the characteristics of the task being undertaken - in particular the susceptibility to changes in requirements as the work is undertaken - contrasts with the degree of 'closure' implied in reaching an agreement. For areas of work that are either not fully or unclearly specified, or in the event of changes to the original set of plans, the agreement serves only to establish the parameters for future negotiation and agreement on these substantive issues, as Sayles and Chandler (1971) suggest. Consequently, while the agreement may constitute a mechanism of control, it is limited in this respect to the extent that it does not fully prescribe the work to be done. The paradox lies in the fact that if the task is to be performed 'effectively' (given high levels of task uncertainty and interdependence) then it requires a framework for interaction that is left imprecise and ambiguous. However, this is not at all the type of arrangement deemed suitable for the establishment of a relationship between the parties engaged in a demand-supply business transaction. The consequences are illustrated in the problems of achieving high levels of technical innovation and in introducing engineering design changes that are reported in the project management literature (eg Barrie and Paulson 1978).

This degree of interdependence in planning and its co-occurrence with processes of negotiation may have important implications for the ability of the organisations involved to engage in negotiating strategies in the subsequent relationship. The point has been made that the nature of planning in a complex and changing project environment, and its close correspondence with the establishment of a formal agreement, makes rather more for a high rather than a low degree of clarity and coverage in product and/or process specification at an early stage. In doing so, subsequent issues that arise and the question of how to deal with them, given some level of initial ambiguity in the specification, may be open to a variety of interpretations. For example, if specific design details are not fully known at an early stage or are subsequently altered, since the actual details depend on or are affected by the actual process of construction, then there is clearly adequate scope for disagreement concerning the validity of the original details of the agreement with respect to that work and the level of remuneration deemed appropriate. It is not difficult then to imagine how the process of reaching an agreement on the issue may involve some degree of negotiating behaviour: for instance, in differing opinions with respect to the 'knock on' effects of the additional work required.

. In general terms it is expected that the more incomplete and/or ambiguous the coverage of the agreement in its substantive content then, assuming the motivation exists, the more likely that the employment of negotiating strategies may occur. The form of the agreement may outline the discretion involved to the participants in reaching a decision as to what levels of work and remuneration

are 'reasonable' in the circumstances. But for this not to provide the basis for some form of negotiation or bargaining requires either the lack of motivation to engage in such strategies on the part of at least one party to the contract; or a matching interpretation of what is considered to be "reasonable" based, for example, upon consistent and unambiguous information concerning the change and the effects of the change; or some other means whereby it is expected that attempts to exert influence in such a way are unlikely to be effective (Rubin and Brown 1975).

Generally speaking, one would expect any feelings of 'latent conflict' stemming from the originally-established terms and conditions to contribute towards the former possibility (for instance if the job is felt to be over/under-priced). Also one would expect differing perspectives and attitudes and the inherent competitive nature of the relationship to contribute towards this possibility, and to lessen the extent to which the latter two may occur. On the question of unambiguous information, Sayles and Chandler (1971) have noted the difficulties in securing, in an interactive setting, the full "visibility" of the parties, and avoiding the possibility of agents or groups withholding information. On the question of the effectiveness of such a strategy, one would expect this to be conditioned by a variety of factors: the availability of information to support one's case; the anticipated benefits available set against the costs of achieving them; the attractiveness of the option with respect to the longer-standing relationship with the other party; the possibility of not furthering the advantage as a means of securing future accommodation via the norm of 'reciprocity' (Homans 1958); and so on (see Rubin and Brown 1975, pp 283-6).

In general terms, the point is that it is not entirely the case that the reaching of an agreement in this type of situation precludes the investigation of subsequent exchange transactions, as some investigations of interorganisational phenomena suggest:

"Once the agreement is signed or otherwise authorised, it throws the relationship into a different light, since interactions are based on a specific pattern rather than ongoing through the exchange process at each interaction episode."

(Hall 1982, p253)

In the type of situation discussed here, one would expect this situation to be variable, depending upon the nature of the agreement initially reached - particularly its clarity and degree of coverage. Generally one would expect a greater degree of "overlap" between, say, design and construction stages of the project to be associated with a tendency towards greater negotiation and more extensive exchange transactions in subsequent dealings. This would be because of the tendency for planning activity and associated exchange transactions and bargaining approaches to run concurrent with the process of construction rather than having unambiguously preceded it. Additionally, the susceptibility of the work to change, and the necessity to replan work, one would expect to be a further dimension leading towards tendencies towards exchange as the work proceeds (by virtue of the simple principles of remuneration for extra work and compensation for changes to the existing specifications that affect already-established plans). The extent to which such exchanges are transformed into bargaining and negotiation strategies one would expect to be guided by any differences in the partys' views of what constitutes either the

appropriate level of work for a given price, or the appropriate level of remuneration for a given level of work.

4.3 The Management of the Contract

The discussion so far has centred upon substantive features of the agreement. It seems appropriate at this point to return to procedural aspects of the relationship as formed during the planning/negotiation stages to assess possible implications for the ability of the parties to engage in subsequent negotiation strategies once the agreement has been reached. One of the central features, discussed in Chapter 1, of the type of organisational arrangement deemed suitable to the kind of task conditions investigated here, is a model of organisation which stresses dual patterns of authority and control, and processes of influence based upon one's contribution toward taskwork processes rather than by virtue of one's formal position, role and jurisdiction. In other words, shared control, jurisdictional ambiguity and dispersed power are requisite features in a matrix setting. Yet these are precisely the types of conditions that have been shown to enhance the possibility of conflict and make likely the adoption of negotiating strategies in an interorganisational setting (Kochan et al 1975).⁹ Integrative mechanisms and an appropriate 'culture' have been suggested as the means by which these inherent features of matrix management may be accommodated in an internal setting (see Chapter 1). However the question arises as to how these features may be accommodated in an external setting where the central integrating device corresponds to the contractual agreement and its formal terms and conditions.

The problem here arises since the model of organisation that is

hypothesised to be appropriate to the types of task conditions studied here, is precisely that model of organisation which yields the most likelihood of there being problems in the relationships between the parties in an interorganisational setting. In seeking to overcome these potential problems the arrangement arrived at - the formal agreement - contrasts what is needed in order to secure the effective performance of the task. This would be the case to the extent that areas of jurisdiction that should be left ambiguous are more precisely demarcated, and patterns of shared control and authority are given greater unity. The task suggests the need for a framework of interaction that 'evolves' and adjusts to complex and changing conditions. The business relationship suggests the need for a structure and processes of interaction that are clearly defined in advance and whose parameters are undebatable.

A similar point arises when one considers the status of the contract as a mechanism of co-ordination and control in inter-organisational relations. Specifically, a contractual framework in effect acts as a relatively "obtrusive" (March and Simon 1958, Simon 1965) means of control in a setting in which, if the transaction was internalised and hierarchically-based, would be most appropriate the use of less obtrusive mechanisms, geared towards influencing the premises for decision-making (Simon 1965, p79) at the operational level. It has been noted that targets, specifications and plans form appropriate, albeit relatively obtrusive, mechanisms of control in a sequentially-interdependent working relationship (Child 1972). However, to the extent that reciprocal interdependence is a key feature of the relationship, one would expect such mechanisms to be inadequate, since management by exception procedures and the resolution

of problems by upward referral would tend to 'overload' the managerial hierarchy (Galbraith op cit). Yet such mechanisms are precisely the types of mechanisms appropriate in the context of a business transaction between parties, since they define and clarify the work to be undertaken and the procedures to be adopted. The problem is that, in an interorganisational setting, potentially relevant axes of unobtrusive control are bound to be heavily influenced by cross-organisational differences in goals and perspectives. In other words, the 'premises' for decision-making (Simon 1965) are dual: corresponding to the sets of goals, assumptions, beliefs, expectations and attitudes brought by each party to the relationship. Perrow (1979) has described succinctly how types of 'unobtrusive' control operate:

"... they limit the informational flow and content, thus controlling the premises available for decision; they set up expectations so as to highlight some aspects of the situation and play down others; they limit the search for alternatives when problems are confronted, thus ensuring more predictable and consistent solutions; they indicate the threshold levels as to when a danger signal is being emitted ... they achieve co-ordination of effort by selecting certain kinds of work techniques and methods."

(ibid, p149)

Perhaps a feel for the problems associated with unobtrusive control mechanisms in an interorganisational context is gained if one substitutes the word "they" for some phrase that links the actions involved with the part played by autonomous agents in articulating these constraints in a transactional relationship. In other words, and following Simon's (1965) scheme, the problems of simplifying decisions to the "bounds of rationality" in an interorganisational

setting, is that one is faced with what amounts to two competing ideas of what constitutes "rationality" to the extent that goal and other (attitudinal) differences underpin the relationship.

This paradox has not gone unnoticed. Indeed it has formed the basis for Sayles and Chandlers' (1971) discussion of problems in the "technical system - business system interface". The potential implications of this for the respective power of role-holders was discussed in Chapter 2. The implications for patterns of inter-agency interaction are discussed here. Sayles and Chandler (1971) have noted the contradiction between the needs for flexibility and rigidity in administrative procedures and managerial processes. They identify the technical system as a less programmed process: alternatives are left open, problems are unpredictable, and control occurs through feedback. The business system, in contrast, is identified as a programmed process; involving the detailing of formal rights and obligations. They suggest that the latter acts as a 'conservative force': while technical system goals stress differentiation, business system goals stress integration (ibid, Ch 13). Given these inherently contradictory tendencies, there is a mismatch between the technical requirements of the task, and the structural form established to integrate and co-ordinate joint activity:

"... (the problem becomes one of) exercising control and gaining co-operation in a work environment which calls for a finely-tuned effort that can be neither specified contractually nor achieved through traditional supervisory methods."

(ibid, p70)

In their scheme, therefore, even well-defined rights and obligations provide an insufficient basis for control in conditions of high rates of technological change or, more generally, high levels of task uncertainty.

There appear to be likely tendencies towards either one of two broad possibilities here. Either extant processes of interaction relate directly to the requirements of the task; or they relate more directly to the requirements implicit in the form of agreement reached. In the first case, one might expect there to arise problems of shared control and jurisdictional ambiguity that may manifest themselves in some degree of 'structural conflict' (Molnar and Rogers 1979) as the relationship develops. At the end of the day, for instance, outstanding problems may be voiced in terms of disputes over which party was responsible for the problem, whether one participant had sufficient authority to take a decision, and so on. In the second case, a more cautious (or aggressive!) contractually-oriented approach may be engendered, in which case the rigidities in interaction described by Sayles and Chandler and deemed 'sub-optimal' (by them and other authors) will tend to emerge. That this may be 'sub-optimal' with respect to the effective performance of the task may be true. However, it is equally valid to suggest that, from the viewpoint of the single organisation in interaction, and given the salience of the business dimension, such an approach is a highly rational one. The issues that arise will be those involving some 'grey area' of contractual responsibility. In the context of a business transaction, such 'grey areas' may involve at best a commitment to extra work with the possibility of not receiving remuneration; at worst, a heightened degree of

vulnerability of the organisations agents in interaction. A second factor, relating back to the earlier discussion, is that the existence of such 'grey areas' may enhance one organisation's ability to make gains at the expense of the other. Assuming, for instance, the motivation to employ negotiation strategies, then their effectiveness may be enhanced by the other parties' vulnerability in a 'grey area' of contractual responsibility (Kochan et al 1975).

What is being suggested here is a form of 'prisoner's dilemma' (Von Neumann and Morgenstern 1944), in which the context suggests that the balance of probabilities means that in all likelihood the latter approach will tend to be that most commonly adopted. Only in the absence of residual 'latent' conflict and where a sufficient degree of mutual confidence and trust exists in the relationship between the parties can one expect the former possibility to necessarily occur. Otherwise, the second condition would tend to hold since, in their contractual relationship, each party will tend to have more to lose than to gain by adopting the more open, collaborative approach which would be consistent with the model described earlier. The likelihood of this being so is further enhanced by the transience of the relationship: in other words in a novel, one-off transaction, and given the learning processes involved, one would expect a tendency towards caution and competition rather than full and open commitment. The relative significance of the individual transaction and the broader relationship between the parties one would also expect to be a significant feature: the less important the transaction (and/or relationship) to one or both parties, the more likely that a cautious and competitive approach may be adopted.

The general point here is that there is an inherent contradiction: to the extent that the nature of the task for effective performance precludes both a complete specification in advance of appropriate patterns of authority and accountability and a unitary, rather than shared, control model of organisation, then a formal structure of interaction that must needs specify fully and unambiguously the roles, rights and obligations of the various parties cannot by definition operate as the requisite model of organisation in these circumstances. Returning to Burns and Stalker's (1966) 'organic-mechanistic' continuum, the framework for interaction embodied in the business system of roles and relationships may be taken to correspond to a 'mechanistic' framework for interaction, in conditions in which a more 'organic' framework may be the most appropriate. The question then becomes one of what implications this potential mismatch has for extant patterns and processes of interaction, and what factors help explain how these patterns and processes are manifested. The foregoing has attempted to identify those factors which may help explain whether co-operation or conflict, consensus or negotiation, will tend to characterise the relationship by focusing upon the conditions that may motivate and influence the ability of one (or both) parties to engage in negotiations. Particular importance has been given to the underlying characteristics of the relationship, and the importance of the dynamics of the planning and negotiation process that may have occurred in its establishment. Attention has also been directed towards the distinction between the potential outcomes in the nature of the relationship as a whole, and specific issues upon which such factors may or not emerge.

Before continuing, a brief series of points needs to be made with regard to relaxing the earlier-stated assumption of a dyadic model of interorganisational relationships. As stated in the previous chapter, interest in this study extends to the totality of relationships amongst the organisations involved in the management of construction work on site. The previous discussion has focused upon bilateral relationships among two interacting organisations. The general point to be made here is that, extending the study to the full range of organisations involved in the interorganisational network complicates immensely the range of possible forms and bases of interaction. It is not the intention here to reiterate the previous discussion allowing for this added complexity, but rather to note briefly three types of situation in a more complex (triadic) system of roles and relationships, and their potential implications, that are of particular interest to this study.

The first concerns the possibility of coalition formation within the network in a situation in which the 'outcomes' available to actors B and C are controlled by a (contractually-senior) actor A. Emerson (1962) has classified coalition formation as a form of 'balancing operation' used to redress imbalances of power between interacting parties. The literature on the reasons for, and processes of, coalition formation is extensive (eg Rubin and Brown 1975) and will not be reviewed here. The point here is simply that the possibilities for coalition formation are enhanced by the types of factors related to the initial reaching of an agreement that were identified in the foregoing discussion. Rubin and Brown (1975), for example, note:

"Coalitions are especially likely to form in competitive multibargaining relationships when power (or other resources necessary for obtaining an outcome) is distributed, or perceived to be distributed, in such a way that one or more of the parties views himself as disadvantaged with respect to obtaining some outcome and does not consider it fruitless to join forces with another in pursuit of the outcomes he seeks."

(ibid, p67)

A similar emphasis on a perceived early disadvantage is found in the results of Festinger and Lawrence (1954), for instance. A range of reasons have been given for understanding which coalitions may form and when: notably, a situation of interdependence and mutual dependence on a third party (Emerson 1962, Thompson 1967); a high degree of 'issue-outcome interest' (Warren 1972, Thibaut and Kelly 1959); the attractiveness or perceived usefulness of another as a coalition partner; and the ability of the dependent parties to mobilise sufficient power to offset the others' advantage (Thibaut and Kelly 1959).

It should be noted that, for the purposes of this discussion, a somewhat generalised concept of power is being used. The emphasis in the above commentary is implicitly upon the exercise of economic power - through the use of informal positive and negative sanctions. However, the possibilities extend to the use of other bases of power. In the context studied here, notably that of expertise and, especially, informational power (French and Raven 1959, Pettigrew 1972). In particular, earlier points were made which pointed to the possibilities of mobilising expert power and controlling relevant information. The latter possibility has particularly been noted as a feature of interaction in project, interorganisational

settings (Sayles and Chandler 1971). The point here is that the possibilities of implicit or explicit coalition formation centred upon specific issues (or perhaps more generally based) may take these latter forms. The process of resolving an issue or reaching a decision may not explicitly involve the exercise of (economic) power within a negotiating framework. Rather it may take the form of less aggressive strategies of persuasion or argument in which two parties join forces to press their viewpoint. The possibility of presenting a 'united front' based upon congruent preferred outcomes for which a common set of cause-effect beliefs and a shared informational base exist is clearly a possibility that needs to be accounted for in a setting of multiparty interaction in which a premium is put upon knowledge and information relevant to the performance of the task. This point is perhaps particularly pertinent when one considers the more structured context within which the parties interact. Models that have been devised of coalition formation and negotiating strategies have tended to concentrate attention upon essentially unstructured settings (eg Thibaut and Kelly 1959). However, as noted earlier, the setting of interest here is one in which a specified and structured framework of interaction exists (in terms of patterns of authority, responsibility and accountability). In setting the limits to the legitimacy of action, such a framework may thereby serve to constrain the extent to which informal processes of influence based upon bargaining and negotiation strategies may be feasible or effective. In other words, forming a coalition and negotiating to pursue one's own preferred outcomes, given that other conditions are highly conducive to pursuing such a strategy, may not be effective if, at the end of the day, the indominus party can simply

exercise their option of whether or not to accept this challenge. In such a situation, one might expect more subtle attempts at influence (based upon persuasion and argument and informed by expert knowledge and information) to be perhaps equally, if not more, effective. Consequently, as a general point, one needs to have an awareness of the characteristics of the structure of interaction as a possible further conditioning factor upon the plausibility of influence attempts based upon a coalitional strategy and the form that this strategy may take.

The second situation of interest, is one in which an actor A wields considerable power over another B, not by virtue of their direct contribution to B's reward-cost outcomes, but by virtue of their role as mediator of the rewards and costs obtainable by B and offered by C. In other words, A is the agent of C who is the actual employer of B. Such a situation is of particular relevance in the triadic system of relationships between client, designer and builder in construction (it also has potential relevance to other triadic systems: notably in the relationships between designer, builder and supplier or subcontractor). In this model, actor A, (the designer) has the ability to influence B's (the builder's) outcomes obtained from C (the client), by accepting or rejecting B's actions. Following Thibaut and Kelly's (1959) scheme, this corresponds to a situation in which the "fate control" exercised by C is "converted" and vested in C's agent (A) who then mediates the outcomes available to B. The situation is of some significance to this study because it suggests the possibility of two-way influence attempts based upon competing bases of power. On the one hand, the position and discretion

available to A in interaction with B suggests the possibility of successful influence attempts based upon formal authority or legitimate power. On the other hand, a correspondence of economic reward-cost outcomes in the relationship between B and C may give B the opportunity of lessening their dependence by by-passing A and convincing C of the benefits to C available by pursuing an action preferred by B but contrary to A's wishes. In other words, there exists the possibility of pursuing a 'divide and conquer' strategy. A lot would clearly depend upon the characteristics of the relationship between C and their agent, A : most notably, perhaps, the degree of independence and autonomy of A and, conversely, the degree of control exercised by C over A. For example, the greater is C's control, and the lesser A's independence, the greater the likelihood of A's decisions being over-ridden by C given the motivation to do so. The next section will return in more detail to these characteristics and their potential implications for patterns of inter-agency interaction. The point to be stressed here is that the position of A in this situation may be one that is either secure or vulnerable to the counter-responses of B to A's influence attempts depending on the circumstances involved.

The third, and final, situation of interest is one similarly in which the role of a third party (D) as mediator of B's outcomes becomes apparent, although the constellation of roles is different. Specifically, it is the situation in which, as above, the outcomes available to B are mediated/controlled by A/C, but where such outcomes are also dependent upon the actions of D whose outcomes are also controlled by C. In other words, B is in a position in

which, even if it follows A's direction, its outcomes may be adversely affected by the actions of D. Further, B may be in a position of dependence upon two parties - A and D - whose requirements and directions contradict and conflict. The position of the main contractor vis-a-vis the architectural and engineering consultants hired by the client serves as an illustration of this possibility. There are also others: for instance, the position of a subcontractor or supplier vis-a-vis the design consultant and the main contractor. Such a situation is of clear importance given the possibility of an interorganisational matrix structure of roles and relationships among groups within the project organisation as a whole. What is being described here is a form of 'role conflict' (Kahn et al 1964) at a group level of analysis. There are a number of possibilities here. For instance, A or D may be able to override one another's decisions by virtue of their comparative positions with respect to C, in order to avoid exploitation of the divide by B (ie one party is able more fully to exert their control over the situation than the other). Alternatively, this divide may be exploited by B by switching allegiance to one party or the other, depending upon which party is able to affect their outcomes most profoundly (generally, or in relation to specific issues), or by exploiting the existence of a more direct issue-outcome interest with C.

Again, what happens will clearly depend upon the characteristics of the network of relationships involved - particularly within the C - A - D triad. For example, the more congruent the goals of C/A and the greater the control of C over D, then the greater the likelihood of A asserting control over D's actions, and the greater

the possibility of B following A's rather than D's directions. Alternatively, the more equal the relationship between A and D relative to C, and the greater the opportunity to B of obtaining access to, and acceptance by, C, the greater likelihood of the divide being exploited by B.

This section has attempted to address briefly the implications for studying processes of interorganisational relationships in a project setting by extending the network to incorporate more complex systems of interaction involving three or more parties, and by relating the possibilities to specific types of situation of particular interest to this study, given the framework of interaction that provides a structural backdrop in this type of setting. In doing so, attention has also been directed in passing towards the potential importance as a set of moderating factors of patterns of control and autonomy within the network. It is to a more explicit consideration of the impact of these factors and, in particular, involving dropping the earlier made assumption of unitary behaviour in external interaction, that the discussion now turns. In the next section, specific attention is turned to considering possible intraorganisational correlates of external interaction.

The final series of points to be made in this chapter concern the implications of internal patterns and processes of co-ordination and control for external interaction in the management of project work. Throughout the previous discussion, occasional references have been made to the implications of addressing processes of interaction between boundary unit personnel of the respective organisations and (latterly) patterns of control within subgroups of the wider project organisation. For the purposes of discussion in the foregoing sections, however, an assumption of some degree of unity of purpose and of direction on the part of each organisation has been made. Yet it should be clear from the discussion in Chapter 1 that, for the single organisation, it is precisely problems of organisation and management in these respects - for example, problems of "segregation" (Kingdon 1973) - which are extensive if the organisation is to organise for effectiveness in conditions of high task uncertainty and interdependence. In a sense this section turns round the discussion of the latter part of Chapter 2: rather than focusing attention upon the organisational response to conditions in a complex and uncertain task environment (including relations with external agencies), the aim is here to highlight the implications of organising in such a way for external processes of interaction. In line with the earlier theme of there being problems in extrapolating the conditions found in internal matrix settings to external ones, a critical component of this discussion is the inherent contradiction that is posed by considering this question. If in the conduct of external relations, and as suggested in the previous discussion, a premium is placed upon

clarity, consistency, unity and concensus on the part of each organisation, then how does this square with the inherent ambiguities, conflicts, disunities and 'negotiated interaction' deemed suitable in the type of task environment facing the organisation? The central issue explored here is the implication for external interaction of internal relationships between the 'boundary unit' involved and the wider organisation.

Interorganisational and collective bargaining research has thrown some direct light upon the sorts of issues addressed here. The research by Kochan et al (1975) for instance, although their results were modest, yielded some support for the proposition that the organisation's ability to interfere with another's goal attainment was conditioned to some extent by the organisation's internal cohesion and clarity. As described earlier, they identified jurisdictional ambiguity, shared control and dispersed power within the organisation as conditioning factors in effective external bargaining relationships. An alternative proposition noted earlier - that organisations faced with a problematic environment may 'tighten up' their procedures for co-ordinating and controlling activity - shares with these results the implication that the operation of an 'organic' task team model within the context of a matrix structure of roles and relationships may not at all be conducive to success in managing external relationships based upon a business transaction. This may be expected to be particularly the case to the extent that the relationship is characterised by bargaining and negotiating strategies. In other words, a 'united front' and 'clear direction' coupled with the ability to bring in higher levels of authority and to rely upon a

more formalised and routinised set of documents and procedures, may prove more effective in pursuing wider organisational goals in interaction. Conversely, one might expect that factors such as some degree of ambiguity or conflict in authority and reporting relationships (stemming from patterns of dual influence), lesser status and authority, and the absence of sufficiently formalised documents and procedures to disadvantage boundary unit personnel in their dealings with external parties. The general proposition here is that the more unitary and cohesive is the internal context for decision-making, ceteris paribus, then the more weight will be given to overall organisational (as opposed to specific functional) goals in external interaction. A second and related proposition is that the more unitary and cohesive is the internal context for decision-making then, ceteris paribus, the more successful will be that agency's strategies in external interaction.

A feature of such a setting which is of particular interest to the issues described here is the position of professionals and functional specialists within the organisation, and their relationships with other professionals in external interaction. Reference has already been made to the possibility of congruent perspectives and orientations across organisational boundaries (see above, pp244-246). Similarities in ways of working and thinking may promote strong ties across organisational boundaries to the extent that functional or professional counterparts are involved in interaction. Such ties may indeed extend to some degree of functional goal congruence. For example, one might be able to envisage groups of engineers getting together to design a technically sophisticated product, while their respective budgetary

controllers attempt to keep the cost implications of this in check. The tendency in the matrix and project management literature has been to view the position of the professional or specialist in isolation from their peer group when involved in a multi-disciplinary team (cf Sayles and Chandler 1971). However, if one takes an external relationship as the focus of enquiry, it may be that such comparative isolation within the organisation is countered to some extent by peer group association within the wider project multiorganisation. For example, each party to the transaction may employ their own legal specialists to administer the contractual relationship between them; or their own technical engineering specialists to cope with the details of product or process specification, design and construction. Such a prospect, to the extent that it occurs, suggests the possibility of a much more variegated relationship between individual or group, project, and organisational goals than is suggested in the matrix and project management literature.

It is not the intention here to review fully the literature on the nature of professionals or professionalisation¹⁰ or, more specifically, on the position and role of the professional within the organisation.¹¹ However it is worthwhile to note a number of general issues that have arisen in studies of professionals within organisations. Specifically, several studies have found the contrasting orientations of managers and professionals (including 'staff' specialists) to be a significant source of conflict within formal organisations (Dalton 1959, Blau and Scott 1961, Gouldner 1959, Stinchcombe 1959, Udy 1965). The position of professionals within bureaucratic organisations is differentiated according to

the relevance of external as opposed to internal norms, values and goals that may guide behaviour. Specifically these relate to the importance of professional peer groups and their institutions as sources of authority, standards, codes and ethics, and as the appropriate means of securing accountability and exercising sanctions (Blau and Scott 1961).

The position of professionals within the task team group in a matrix setting has, of course, received a good deal of attention with respect to issues of motivation, commitment and so on (see above p1.31). However the particularistic patterns of external interaction in a matrix setting and their implications for the position and role of professionals and specialists in the wider project organisation - with respect to their degree of autonomy or dependence - has received somewhat less attention. Such an omission is odd, since one might expect these conditions to have an important bearing upon the nature and form of interaction at the operational level. To the extent that the nature of the task requires a decentralisation of decision-making authority to operational levels, where interaction with external agents may be extensive, then the position of the professional or specialist is somewhat distinct from the role of mainstream personnel undertaking main 'line' activities. From the viewpoint of the organisation, the existence of broader professionally-based standards, norms and values and, more specifically, their shared nature in peer group interaction across organisational boundaries, might be expected to contribute towards a further attenuation of the link between broader organisational and specific functional goals. The premises which guide the professional or specialist in that setting

may be more professionally-orientated - a possibility that may be enhanced and reinforced by greater 'localised' peer group interaction. Following Kingdon's (1973) scheme, the possibility of "segmentation" and lateral "dissociation" may be affected by the positive pull of congruent norms, values and goals across organisational boundaries. From the viewpoint of the individual professional or specialist (or subgroup), the reverse set of conditions (ie greater organisational control and lessened autonomy) may heighten tendencies towards conflict of interests and a degree of compromise in their understanding and performance of the role. Such conflicts may be lent a heightened awareness and assume a greater insidiousness given extensive peer group interaction at a more 'local' level. Put more simply, the phrase "I would like to agree with you, but I can't" may be a statement symptomatic of what constitutes a latent conflict of interest. Whether such a situation occurs and is salient to those involved, depends of course upon a variety of circumstances - generally, the juxtaposition of organisational and professional interests in relation to the specific issue at hand and the dynamics involved. Clearly, however, the prospect is an empirical possibility that needs to be borne in mind. It may help to explain both more 'obtrusive' patterns of organisational control that occur, and also any degree of role conflict felt and articulated by those involved. It is not simply here that the organisation's agent may be subject to two sets of conflicting orientations (the one functional, the other project). In an external setting, this possibility is added to by an orientation towards project work as it is not mediated by organisational goals and interests. To draw the distinction one might compare two subtly different conceptions of, say, the engineer's

processes. However, if one draws a distinction between the position of the integrator in an internal and external setting, then certain implications follow for a fuller understanding of the role in project environments. The earlier noted tendency to equate a project management function in both an internal and external setting simplifies what in practice are two very different types of situation. In the internal setting, the integrator is expected to be a neutral facilitator and adjudicator in inter-functional team relationships. In the external setting, the integrator is expected to be a neutral facilitator and adjudicator in inter-organisational team relationships. If one assumes that each party has their own project manager to perform the former function, but that there is no intermediary to perform the latter function within the wider project organisation, then one would expect that, as well as facilitating inter-functional interaction internally, one of the main functions of the respective integrators would be in conducting negotiations and bargaining with their counterpart(s) in the other organisation(s) (their involvement depending perhaps upon the issue at hand and its 'importance'). In other words, a central component of their role would be giving a lead to the individual organisation in external negotiations and resolving disagreements. The role becomes one similar to that described by Likert in the project manager's role in performing a 'linking-pin' function, albeit in an external setting:

"... the leader fully reflects and effectively represents the views, goals, values and decisions of his group in those other groups where he is performing the function of linking his group to the rest of the organisation. He brings to the group of which he is the leader the views, goals and decisions of those other groups. In this way, he provides a linkage

whereby communication and the exercise of influence can be performed in both directions."

(Likert, 1961, p171)

In this situation it is performing a "boundary control" function, as much as "goal achievement" and "systems maintenance" functions (Herbst 1974) that comes to the fore.

If one then assumes further that an autonomous intermediary is in the position of mediating relationships between organisational groups, then one would expect (to the extent that conflict and/or negotiation processes occur) a quite different role to be performed. As much as acting as a 'facilitator' or 'decision-broker', one would expect that their role is one of acting as conciliator, arbitrator or adjudicator and perhaps even decision-maker in the absence of consensus, given the competing and conflicting demands that need to be reconciled. There is a subtle difference here in the differential sets of role requirements involved. Broadly speaking, in this latter situation, each organisational integrator is acting in the capacity of a 'champion' of their own organisational interests with respect to the project: their role in the wider project organisation is one which compares closely with that performed by their functional department or section-head counterparts within their own organisation; the difference being that external rather than internal relationships are the focus of their activity. The intermediary, on the other hand, is acting in the capacity of a 'champion' of project interests and, in doing so, their central focus of interest is in managing and mediating what are mainly external relationships amongst the organisational groupings involved. Following Galbraith's scheme (op cit) the latter perhaps corresponds to the performance of a 'managerial linking role' rather than integrator in the generally-held sense of the word. The difference lies in the normative basis underlying interaction : to

some extent the norms, values and goals underlying interaction in an internal setting will be shared to an extent that is perhaps less likely in an external setting. A specific orientation towards the project is the same. But the unity of purpose this may generate in an internal setting is a qualitatively distinct phenomenon from what will occur in an external setting simply by virtue of what this represents to the participants involved in each case. In an internal setting, project objectives represent a link between functional and wider organisational goals (which may converge or diverge). In an external setting, project objectives represent a link between sets of organisational goals (which are more likely to diverge). In the latter case, functional goals may be a complicating factor. However the essential link is a lateral one - between organisations - rather than a hierarchical one - as in the relationship between functional departments and the wider organisation. In occupying the position which corresponds to 'championing' the project objectives in each case, the types of functions undertaken by the two types of integrator are likely to differ according to the respective difference in the constellation of relationships between objectives and goals. Put more simply, an in house integrator is likely to be able to depend upon a much greater degree of consensus amongst the groups they are co-ordinating than is an external intermediary integrator.

For the organisation as a whole, the prospect is that the problems of achieving sufficient levels of co-ordination and control made salient by the dispersion of discretionary authority and associated problems of 'segregation' (Kingdon 1973), are compounded by the susceptibility to the constraints and contingencies

arising due to the impact of relations with external agencies. In that type of situation, one might expect more 'obtrusive' mechanisms of control, a greater concentration of authority, and greater structuring of activities to be the means whereby an appropriate degree of co-ordination and control is obtained. For example, one might expect that negotiation and/or conflict at the interface between organisations will lead to a greater degree of involvement by senior management personnel and their greater influence in joint decision-making. Such a possibility has been noted by Warren (1972) who includes the degree of organisational 'inclusion' as a parameter in joint decision-making: reflecting the extent to which problems are 'escalated' to higher levels within the respective organisations for resolution through agreement or negotiation. More obtusely, one of the possibilities not accounted for in Likert's (1961) 'system IV' model of participative influence within the organisation was the possibility of some degree of 'external threat', that might constrain the ability of that model to operate effectively in particular sets of circumstances.

The main thrust of the models of matrix and project management discussed in Chapter 1 is that, in conditions of high task uncertainty and interdependence, traditional bureaucratic mechanisms and forms of co-ordination and control are insufficient for achieving simultaneously the degrees of functional differentiation and integration required. The relevant dynamics are the problems of 'segregation' that occur and associated power disparities in interaction. The relevant mechanisms for achieving a sufficient level of co-ordination and control then involve the establishment of a framework for interaction that allows for these tendencies by incorporating and internalising

in the structure the ambiguities and conflicts involved. Consequently the problems are not removed, they are internalised (Knight 1977) and manifested in the contradiction of long-standing principles of organisation (eg unity of command) and in problems for those involved in the organisation (eg role ambiguity and conflict, stress and so on). The prospect that is raised here is that, faced with an external 'threat' (eg another organisation adopting an aggressive bargaining strategy), then there are two broad options available. Either the organisation is left vulnerable to this threat, or it responds to counter it. It is hypothesised here that, if the latter option is taken, it will tend to be more successful to the extent that the strategy reflects a contradiction of the principles inherent in developing and maintaining a matrix system of management.

Footnotes

- 1 "Mandated" bases for interaction have been identified as a third alternative to exchange and power-dependency relationships in interorganisational networks (Hall et al 1977, Warren 1967, Turk 1970, 1973, Schmidt and Kochan 1977, Raelin 1980). The distinguishing feature here is the existence of a structured, and evolving, legal-political framework for interaction (Raelin 1980, pp58-59). The most common application of the construct has been in the study of non-commercial relationships; although formal agreements between business organisations in mergers and joint ventures form a relevant subset (Pfeffer 1972, Pfeffer and Nowak 1976, Aiken and Hage 1968, Clark 1965). Exchange, power-dependence and 'mandated' bases for interaction are inter-related: for instance, the latter may 'evolve' historically from less formal exchange relationships, and their operation may be characterised by exchange relationships (within a formal legal framework). Indeed, in many ways the situation described here (ie the construction industry) crosscuts the three models: the relationship is a voluntarily entered-into exchange transaction between parties, which occurs within the context of a contractually-based legal system of definitions of their respective rights and obligations; further, as noted in Chapter 2 and to be discussed further in this chapter, the terms and conditions reached may substantially reflect conditions of power-dependency in the broader economic relationship between the parties.
- 2 A related, but distinct point concerns the degree of "domain concensus" or "dissensus" at a more macro level within the industry. For example, the question of the role of building firms in product design, or of design firms in direct construction management (eg Higgin and Jessop 1965). The broad debate in the interorganisational literature centres around whether relationships can be formed - and if so, how are they characterised - in conditions of 'concensus-dissensus' (eg Cook 1977, Aldrich 1979). A discussion of this issue is beyond the scope of this thesis. However, it should be noted that the basis of the relationship in construction may embody some degree of 'domain dissensus' to the extent that different interest groups (clients, the professions, builders) have an interest in expanding or contracting their domain in order to reduce dependency on the other groups. It should also be noted that the situation is an historically developing and changing one (see, for instance, Higgin and Jessop (1965) for a more detailed discussion of the historical development of client - professional - builder relationships). The general point is that locating the status quo at a particular point in time presents only a static picture of what may be significant changes in the positions, roles and relationships of parties within the industry at a broader institutional level.
- 3 In 1980 a new form of standard contract was introduced by the Joint Contracts Tribunal to replace the earlier (1963) edition. For a discussion of the implications for the legal rights of the respective parties, see for instance Fellows (1981).

- 4 A close analogy here is in the developments and changes in the relationship between trade unions and employers within an institutional collective bargaining framework. For a discussion of the implications see, for instance, Lumley (1980).
- 5 A similar point is made with respect to industrial relations phenomena: it might be argued here that the diverse literature on interorganisational relations, industrial relations and economic transactions in industry share some common ground which is seldom explored and integrated.
- 6 The history of case law in construction provides, of course, a multitude of illustrations of debates centred upon the exercise of discretionary authority.
- 7 Such conditions of price consistency and performance specificity have been taken by Williamson (1975) and Ouchi (1980) as those conditions appropriate to the establishment of a market-based mechanism of control.
- 8 Which suggests, according to Williamson (1975) and Ouchi (1980) the appropriateness of a hierarchical mechanism of control.
- 9 In an intraorganisational context, these factors have also been shown to be of significant importance as antecedent conditions in the emergence of conflict between subunits (Walton, Dutton and Cafferty 1969, Filley and House 1969).
- 10 For a review, see for instance, Johnson (1981), Esland et al (1975, chs 18 and 19).
- 11 See, for instance, Blau and Scott (1961).

CHAPTER FIVE

A STUDY OF CONSTRUCTION ORGANISATION AND MANAGEMENT

The previous three chapters have involved a review and critique of models of the structure and processes of interaction within complex (project) organisational settings, and have attempted to relate the issues raised to the circumstances found within a construction project setting. In doing so, particular attention has been directed towards the apparent contradictions that emerge when one considers a situation in which the preconditions for inter-organisational interaction conflict with the requirements posed by the nature of the task. It is this 'tension' in the relationship between, respectively, "business" and "technical system" requirements that has been the centre of interest in the foregoing discussion and, it is argued, a set of factors the implications of which tend not to be addressed fully in the literature and research upon forms of matrix or project management. The discussion has suggested something of a central paradox: namely, that the centrality of the interorganisational dimension puts a premium upon an organisational response that involves the contradiction of many of the facets deemed requisite of complex organisational forms operating under conditions of task complexity, uncertainty and interdependence.

In addressing this paradox, particular attention has then been directed towards assessing the factors which may contribute towards an understanding of patterns and processes of interaction observed in a construction project setting. The discussion has centred upon those factors which one might expect to affect the motivation

and ability of the actors involved to exert influence in decisional processes, and the manner in which this may be exercised - through negotiation and bargaining strategies for instance. Factors including the relationship between project and organisational goals, the power-dependence relationship between parties, and the breadth and longevity of interorganisational linkages have been highlighted as central components in studying the motivational basis underlying interaction. Factors including the work relationship pattern between organisations, the formal framework for interaction, the degree of clarity and coverage in the task remit, and internal structural characteristics of each firm in interaction, have been highlighted as central components in studying the ability of organisations to realise their wider organisational goals in interaction.

The intention of this chapter is two-fold. In the first half of the chapter, the strands from this earlier discussion are brought together in a model of the structures and processes of interaction in the organisation and management of construction project taskwork, from which a series of explicit propositions are derived and formally stated. The intention here is to keep the discussion brief, since the propositions derived have been discussed in more extensive detail in the foregoing two chapters. In the second half of the chapter details are given of the methodological approach adopted for the investigation of these propositions, and of the sample of construction projects upon which the research reported in this study was undertaken. Particular attention here will be directed towards: the nature of the sample and basis for selection; the fieldwork undertaken and the methods employed; the procedures used in the collation and presentation of the data

obtained and reported in Chapters 6 to 10; and the rationale underlying the stages of analysis and interpretation and their presentation in Chapters 11 and 12.

5.1 A Model of the Structure and Processes of Interaction in Project Management

There are a number of sets of propositions to be advanced in this section. The first set concerns what may be expected in terms of a broad model of organisation and management in conducting construction project taskwork, and relates to the issues described and commented upon in Chapter 1 above. This reflects a general interest in the understanding of the association between task attributes and structural characteristics: the broad question is one of the association between the nature of the task and extant characteristics of the forms and processes of interaction. Whether, specifically, the patterns and processes observed in the organisation and management of construction task work are 'conducive' to the effective performance of the task. Or whether, in contrast, they tend to reflect characteristics other than the immediate requirements of the task (for example, whether the procedures adopted and enacted are habitual or 'contract-inspired' and static, as opposed to being responsive to the circumstances faced and change in those circumstances over time). The later sets of propositions are more specific and concern what may be expected in terms of processes of interaction between organisations in the management of construction work given the situation earlier described. These propositions relate to the more specific issues raised in Chapter 4, and reflect an interest in examining the range of possibilities in the form and content of interaction (for example,

whether decisional processes exhibit tendencies towards consensus, compliance or compromise through negotiation strategies; whether, and to what extent, conflict or cooperation characterise the relationship). Due to the potential complexity in the interrelationships between the sets of independent variables that will be looked at, and the potential range of observable outcomes with respect to these two sets of issues, the intention here is not to supply a complete formulation that allows one to account for the full range of empirical possibilities. Instead, these sets of propositions are presented rather more as a set of guidelines for the later analysis, interpretation and discussion of the empirical findings.

Figure 5.1 below depicts the sets of variables of interest to this study and their possible interrelationships. It should be emphasised that, while the lowest box represents what constitutes the set of dependent variables in this study, interest is as much centred upon the complexity in the interrelationships amongst the sets of variables depicted, as in the dynamics of the mechanisms involved. Consequently, two-way directionality in the relationships between the sets of variables has been specified. The following constitute the four sets of factors of interest to this study as 'contextual' factors which will help to explain observed patterns and processes of interaction in the management of construction project work on site:

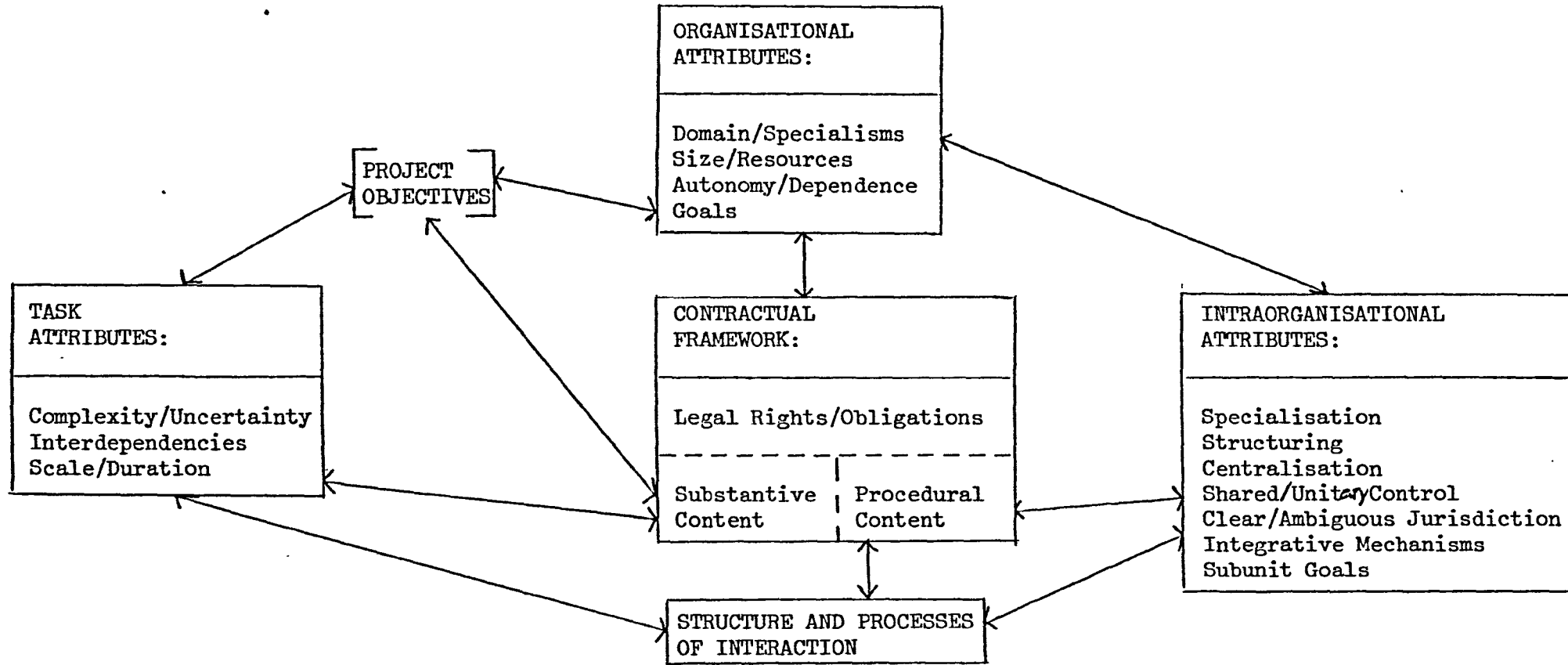

Figure 5.1 A Model of Structures and Processes of Interaction in the Management of Construction Project Work

- (i) Task Attributes: The specific features of the task - namely the objectives to be achieved, the resources and techniques involved and spatial and temporal constraints. More generally, levels and types of complexity, uncertainty and interdependence in the performance of taskwork and the total scale and duration of operations.
- (ii) The Contractual Framework: The nature, level and extent of the specification of the work to be performed, and of the procedural mechanisms employed in the management of taskwork. Also the basis of the agreement (eg whether negotiated or not), and the juxtaposition of the process of reaching the agreement with the design/planning processes that were involved. More generally, the pattern of legal rights and obligations conferred upon the parties under the contract.
- (iii) Interorganisational Relationships: The attributes of the organisations involved in terms of their goals, scale, autonomy and resources; and the broad relationships between the organisations involved in these respects. More specifically, the 'location' and importance of project objectives and the interorganisational relationship with respect to each organisations' mainstream operations as a whole.

- (iv) Intraorganisational Attributes: Structural and processual characteristics of the organisations involved (in terms of degrees of centralisation and structuring of activities, etc), including the extent to which dual patterns of management occur, and the types of mechanisms employed to achieve integration, and the coordination and control of subunit operations.

The aim is to explore the nature and extent of the impact of these sets of factors upon, and to assess their interrelationships and implications for, the forms and processes of organisation and management within the 'project organisation'. Of interest here is, broadly speaking, the occurrence of an 'organic' or 'mechanistic' model of interaction in the management of project work on site. Of particular interest also is the potential occurrence of dual patterns of influence and control in the management of the task, and the manner in which problems are solved and decisions reached in this context.

5.1.1 Task and Organisational Attributes

The first set of propositions concern the association between attributes of the task being performed and the extant forms and processes of organisation and management necessary for the effective coordination and control of taskwork on site:

- 1 The greater the complexities, uncertainties and interdependencies in the performance of work on

site, the more appropriate will be tendencies towards an 'organic', as opposed to 'mechanistic' model of organisation and management.

- 2 The greater the complexities, uncertainties and interdependencies in the performance of work on site, and the more that this is manifested in a high level of functional and role specialisation, the more appropriate will be a structure of interaction that involves the use of integrative mechanisms.

These are essentially the propositions put forward by Burns and Stalker (1966) and Lawrence and Lorsch (1967) respectively. The types of 'integrative mechanisms' expected here correspond to the more sophisticated forms described by Lawrence and Lorsch (1967) - such as committees and the use of integrators; they also perhaps extend to the possibility of some form of matrix management (Knight 1977). The questions of what specific forms may be expected and whether they are established formally or 'emerge' more informally, are left open as empirical questions to be investigated.

The scale of operations is expected to have an impact here. Generally, it is expected that larger scale will be associated with tendencies towards a more 'mechanistic' framework for interaction: this is because of the effect that increasing size has upon levels of formalisation and routinisation in work procedures at the operational level (Hull and Hage 1982), and also due to the tendencies towards greater specialisation in functions and roles that are likely to occur. Given the latter tendency also, it is expected that larger

scale will be associated with the greater use of (formal or informal) integrative mechanisms: this due to the greater need to co-ordinate and control the contributions of a multitude of diverse specialists involved in work on the project. Consequently:

3 In conditions of high task complexity, uncertainty and interdependence, the larger the scale of operations, the more 'mechanistic' the model of organisation and management that will occur.

4 In conditions of high task complexity, uncertainty and interdependence, the larger the scale of operations, the more extensive the use of integrative mechanisms in the structure of interaction.

In other words, if a more 'organic' model is appropriate, then it is suggested that the ability of this model to effectively operate, or even perhaps occur, will be constrained by the effects associated with the size of the project organisation.

At the same time, however, size is expected to affect the 'location', as it were, of these mechanisms. Generally, one would expect increasing size to be associated with a pattern of more decentralised control over the construction process within the project organisation as a whole, and with a greater significance attached to managerial interaction in problem-solving and decision-making processes at the operational level (or 'on the ground'). To the extent that this is the case, then it is expected that:

5 The larger the scale of operations in conditions of high task complexity, uncertainty and interdependence, the more likely that structural mechanisms established or emergent to achieve integration will be found at the operational level (ie on site).

It is suggested here, for instance, that a (formal or informal) pattern of matrix management will be observed at varying levels of the administrative hierarchy dependent upon the scale of operations involved. A similar suggestion is made for other 'integrating mechanisms' (eg committees, integrators, managerial-linking roles, etc).

5.1.2 The Impact of the Formal Agreement

The above propositions have been made assuming the neutrality of any effects upon the extant forms and processes of interaction observed associated with organisational differentiation within the project team as a whole. Relaxing this assumption allows for a set of propositions that concern the association between task attributes and extant forms and processes of interaction in the context of a formal business agreement and a contractually-based administrative framework that links the parties. In particular, it is predicted that given goal divergence and a more even power differential amongst the parties, the more likely that these factors will emerge to the fore in decision-making processes, and, consequently, the more important will become "business system" considerations (Sayles and Chandler 1971) in joint interaction. The conditions that are

likely to give rise to such a situation are explored in more detail in propositions 8 - 22 below. The general propositions to be made here are:

- 6 The greater the salience of "business system" factors, in interaction, the less likely that an 'organic' model of organisation and management, conducive to performance in conditions of high task complexity, uncertainty and interdependence, will emerge and be maintained.

In other words, the greater will be the tendencies towards the 'rigidities' in interaction described by Sayles and Chandler (1971): a stance in interaction informed by role not process, and by one's formal position under the contract. Conversely, the more routine, certain and lower in interdependencies the nature of the task, the more likely that such a model based upon formal 'business system' considerations will occur and be appropriate. Also it is expected that, given a tendency towards a greater degree of 'structuring of activities' in large scale operations (proposition 3), any problems associated with a 'mismatch' between the 'technical' and 'business' systems are likely to be greater where the scale of operations is small. Thus:

- 7 The smaller the scale of operations, the more inappropriate will be a more 'mechanistic' model of organisation and management based upon 'business system' considerations in conditions of high task complexity, uncertainty and interdependence.

In other words, it is these conditions (smaller scale, more complex task, etc) that are taken to be most conducive to the emergence and maintenance of a framework for interaction with the small, 'organic' task team group at its centre. On larger scale operations, such a framework is perhaps less likely to occur anyway and, correspondingly, the impact of formal business system considerations may be less profound. In comparison, where the task is routine, certain and low in levels of interdependence, and where the scale of operations is large, the least inappropriate is expected to be a model of organisation and management run on formal business system, 'mechanistic' lines. In other words, in this situation one might expect the observed tendencies to approximate more closely towards those of the classic bureaucratic model.

So far, the propositions made have been concerned with attempting to predict the association between task attributes, the formal framework and structure of interaction, and extant or actual conditions. This next set of propositions is concerned with addressing the dynamics of the processes involved in the establishment and development of the relationship(s) as antecedent and developmental conditions that may help to explain the juxtapositions between the three set of factors described above. Bearing in mind the predicted moderating impact of the scale of operations involved and variability in the characteristics of the task in exploring any divergence between the extant and formal structures and processes of interaction, the specific focus here is upon the types of conditions that may prompt tendencies towards an interactive stance based upon 'business

system' considerations in conditions where the scale of operations is relatively small, and the task is high in levels of complexity, uncertainty and interdependence. Conversely, interest is focused upon how these conditions may be consistent with more 'organic' tendencies in interaction, despite the salience of business system considerations.

The antecedent conditions refer to the nature of the relationship in terms of its 'pre-history' and early establishment. It is predicted that a greater attachment to more formal patterns and processes, in at least the early stages of the relationship, will occur to the extent that:

- 8 The relationship between the parties involved is a new experience.

In this case, one would expect the level of confidence and trust of each party in the other not to be initially sufficiently high enough to engender a more informal, flexible approach, and for caution and greater formality to characterise the relationship in its early stages. Conversely, the longer-standing the relationship, and the greater the familiarity and experience of working with each other, the more likely that the early stages of the relationship will be characterised by greater flexibility, openness and commitment in joint interaction.

Secondly, the extent to which:

- 9 The parties differ in their expectations and

assumptions concerning how the work is to be organised and managed.

This possibility is likely to be associated with that described in proposition 8. However, despite familiarity and experience, it may be the case that attitudes simply conflict: the parties have worked together before and essentially agree to disagree on the appropriate way of handling the project. In this case, one would expect the outcome to be a tendency towards an emphasis and reliance upon 'business system' rather than 'technical system' considerations, given the salience of the contractual dimension.

The following proposition pertains also to antecedent conditions in the relations, but refers more specifically to the particular attributes of the current relationship and its initial establishment. Whereas propositions 8 and 9 refer to potential 'difficulties' experienced in interaction, proposition 10 relates to a more 'proactive' response based upon 'business system' considerations. As such it reflects the motivation on the part of at least one party to further their interests in subsequent joint interaction, and the likely impact that this is expected to have upon the form of the relationship - at least in its early stages. Specifically, a tendency towards more formal patterns and processes of interaction based upon the contractual relationship will be exhibited if one or more parties has the motivation to pursue their own goals in interaction. This will be the case to the extent that:

- 10 The establishment of the relationship has been characterised by processes of interaction

(eg bargaining) in which at least one of the parties has been left feeling disadvantaged with respect to the terms and conditions reached. Further that the outcome of the project with respect to organisational goals is critical to at least one of the parties, and developing a 'good working relationship' with the other party is less critical to organisational fortunes in the long run.

Corresponding to this set of antecedent conditions, are a set of conditions that pertain to the development of the relationship, as work involved on the project proceeds. The broad question here is whether a 'virtuous' or 'vicious' circle will arise. In other words, whether an 'appropriate' model of interaction, given task characteristics, will emerge. Firstly, assuming that the parties experience relatively few 'problems' in interaction with one another:

- 11 The more likely that the longer the duration of the relationship will promote tendencies towards mutual accommodation.

In other words, a 'convergent' model of processes of interaction will be observed. Conversely, the shorter the time period involved, the less opportunity there will be for this convergence to occur. This possibility relates to one aspect of the 'learning period' - the time scale of interaction. In terms of the events that occur, it is further expected that:

12 The greater the number of 'problems' experienced by at least one party during the course of interaction, the greater the likelihood that starting assumptions and expectations will be reinforced, and the more likely that a 'vicious' circle may occur.

Conversely, the fewer the 'problems' experienced in interaction, the more likely it is expected that starting assumptions and expectations will be modified and adjusted in response to events, and the more likely a 'virtuous' model - or 'convergence' in the parties' stance towards one another - will be observed.

In parallel with the more 'proactive' motivational responses highlighted in proposition 10, it is expected that:

13 The more that specific issues emerge that allow at least one of the parties to redress an initial imbalance in the relationship; the more critical that these issues are to the pursuance of organisational goals on the project; and the less critical is felt to be the maintenance or development of the quality of the existing working relationship between the parties - then the more likely that this 'vicious' circle may occur.

Conversely, the fewer the issues that occur, the more insignificant they are, and the more importance is attached to the working relationship, then the more likely that a 'convergence' in the parties'

orientation may occur.

5.1.3 Influencing Outcomes in Interaction

The foregoing propositions have focused upon characteristics of the relationship, its development, and the context of its establishment and development, as factors that may explain why certain circumstances may arise. The following propositions are concerned with how these may arise. In other words, assuming the motivation to influence processes of joint decision-making (given propositions 10 and 13), the question now arises of what factors determine the ability of the parties to effectively influence the processes of decision-making, and, conversely, what factors determine their vulnerability in joint interaction. The general argument pursued here is that the greater the motivation of at least one party coupled with their ability to exert influence in decisional processes in order to pursue organisational interests in interaction, then the greater the tendency for decisional processes to be characterised by bargaining and negotiation processes (or attempts at), the more likely that recourse will be made to formal mechanisms to secure compliance (rather than acceptance), and the greater the likelihood of conflict and/or competition between the parties (cf Kochan et al 1975).

Firstly, it is expected that, in relation to the task being performed:

- 14 The more unambiguously and fully specified the task remit (in terms of the specification of

objectives and means to achieve those objectives), then the less scope available to the participants to pursue their own interests in interaction.

Here attention is directed towards the degree of coverage and level of substantive detail specified in the contract; the extent to which it allows for unambiguous interpretation; and the less susceptible is the specification to change and variation as the work proceeds. Generally, the more fully explicit the remit established by the demand-side party and accepted by the supply-side party, the less the former's vulnerability in interaction, and the less likely to be successful any attempts made by the latter party at pursuing their own interests in interaction. Conversely, the more vague, ambiguous and changeable the remit, the greater the former's vulnerability, and the more likely the success of influence attempts.

Secondly, in relation to the formal structure of interaction, it is expected that:

- 15 The more clear cut, consistent and unitary the formal pattern of control (in terms of the parties' formal roles, relationships and jurisdictions), then the less scope available to the participants to pursue their own interests in interaction.

Here attention is directed towards the formal position power of one party vis-a-vis the other under the contract and the extent of access to realisable formal sanctions. Also incorporated are the extent to which patterns of control are unitary as opposed to dual,

and the extent to which each parties' jurisdiction is clear as opposed to ambiguous. Generally, the more that these conditions hold, the less likely that the demand-side party will be vulnerable in interaction, and the more unsuccessful will be the supply-side party's attempts at exercising influence to achieve their goals. Conversely, the less formal positional power the demand-side party has at their disposal, the more that areas of control and jurisdiction are open to question, the greater their vulnerability, and the more likely the success of influence attempts made by the supply-side party. It is here that the earlier-noted significance of 'grey areas' of contractual responsibility are relevant.

Thirdly, and in relation to the broader relationship between the parties:

- 16 The more evenly-dispersed are more informal bases of power amongst the participants (in terms of economic power and independence, the possession and control of needed expertise and information), then the more likely that interaction will be characterised by successful attempts by the parties to pursue their own goals in interaction.

Here attention is directed towards the degree of 'balance' in the power-dependence relationship between the organisational participants. Generally, the greater the degree of dependence of one party on the other for relevant economic and informational resources as well as expertise, the more likely that that latter party will be able to successfully influence the decisions reached jointly by the parties

in interaction. Conversely, the more 'balanced' the relationship in these respects, the less able will either party be to exert their influence effectively on a continuing basis. In these latter circumstances, the relationship is likely to be characterised by a high degree of 'give and take'.

Fourthly, and in relation to the intraorganisational attributes of each organisation, it is expected that:

- 17 The more unitary and cohesive the internal setting, and the greater the power vested in organisational agents in external interaction, then the more likely that that organisation will be able to effectively pursue their interests in interaction.

Here attention is directed towards the extent to which wider organisational goals are internalised by the team operating at the boundary; their level of authority and status within the organisation; the degree of control over needed resources, expertise and information coupled with wider support in these respects for those operating 'on the ground'; and the degree of clarity and consistency in areas of jurisdiction and patterns of control. Generally, the more (less) these conditions hold, the less (more) vulnerable and more (less) influential is expected to be that party in external dealings. In other words, it is here that the implications of tendencies towards either a 'united front' or a 'divided front' are relevant.

Corresponding to this last set of four propositions (14 - 17),

are a further, and final, set of four propositions to be made which relate to the outcomes that are subsequently achieved by the parties in interaction. If one party proves either vulnerable to the influence attempts successfully made by the other, or alternatively, is unsuccessful in achieving their desired outcomes in interaction, then one would expect one or a combination of the following four broad strategies to be pursued in order to either lessen their experienced vulnerability or to help ensure success in future dealings. Firstly, to the extent that the characteristics of the specified task to be performed have proved to be problematic, one would expect that:

- 18 Problems experienced in interaction due to shortfalls in the specification of the task, are likely to be countered by attempts made to clarify, cover and make certain the substantive details of the work involved as they impact upon organisational outcomes.

The initiation of these moves is expected to come from the most affected party. Two broad sets of possibilities are apparent here. On the one hand, one might expect moves to specify the details involved, based upon a process of agreement or negotiation aimed at resolving this source of 'operating conflict' (Molnar and Rogers 1979). On the other hand, attempts to delineate and demarcate responsibility for the omissions, ambiguities, inconsistencies, variations and so on may occur. Thus for instance, parties may attempt to place the blame at the other's door, make unrealistic requests for details and decisions, rely on their contractual power to instruct and enforce the other's compliance, and so on. One

would expect the broad approach taken to depend upon the salience of the issue to the parties involved, its significance as a source of dispute, and the quality of the existing relationship. If the latter approach is adopted one might expect that similar problems in future joint interaction are more likely to emerge, since the issues have not been resolved and the source of potential conflict remains 'latent'.

Secondly, to the extent that jurisdictional and other structural problems have emerged, one would expect that:

- 19 Problems experienced in interaction due to characteristics of the structural framework for management of the work, are likely to be countered by attempts made to clarify, make consistent and more certain areas of ambiguity and shared control and responsibility as they impact upon organisational outcomes.

Again the initiation of these moves is expected to come from the most affected party, and again there are two broad sets of possibilities. On the one hand, one might expect moves to specify more clearly and precisely areas of jurisdiction and control based upon a process of agreement or negotiation aimed at resolving this source of 'structural conflict' (Molnar and Rogers 1979). On the other hand, attempts to extend control over areas in dispute or to 'offload' the responsibility of the organisation with respect to those areas may occur. Thus, for instance, attempts to avoid or minimise one's responsibility, to 'cover' oneself, to 'pass the

buck', to debate others' authority to take decisions and so on may occur. Again one would expect the broad approach taken to depend upon the salience of the issue to the parties involved, its significance as a source of dispute, and the quality of the existing relationship. Again too, if the latter approach is adopted, one would expect that similar problems in future joint interaction are more likely to re-emerge, since the issues have not been resolved, and the source of potential conflict remains 'latent'.

Concerning the broader relationship between the parties:

20 Vulnerability or lack of influence in joint interaction may be countered by the 'mobilisation' of resources.

Here, the possibility of coalitional strategies to redress power imbalances between the parties is of potential relevance. However other strategies related to differing bases of power may be observed: notably, countering expert power by bringing in one's own experts (eg technical or legal personnel); or attempting to control and make use of information needed by other parties.

With respect to internal characteristics of each of the parties in interaction, it is expected that:

21 Vulnerability or lack of influence in joint interaction may be countered by a strategy of 'tightening up' internal procedures and mechanisms, and by exerting more direct and centralised

control over interaction processes.

This may include a higher level of involvement and influence of senior management personnel in joint interaction at the operational level; the strengthening of integrative mechanisms with respect to functional staff - including extending the authority and influence of those performing integrator roles; the adoption of more 'obtrusive' mechanisms of control (eg more extensive documentation, more formalised procedures and so on); and attempts to clarify and make more consistent areas of shared or ambiguous authority and responsibility within the organisation with respect to management of the work involved on the project.

Given these final four propositions, the final one to be stated is that:

- 22 The more extensively these strategies occur in the dynamics of interaction between the parties, the less likely that orientations towards managing the work will 'converge' over time, and the less likely as a consequence that an 'organic' model of organisation and management conducive to performance in conditions of high task complexity, uncertainty and interdependence will be realised.

In other words, the greater the tendency towards the employment of these strategies, the more likely that, within the project organisation as a whole: problems and decisions will be 'escalated' to higher levels for resolution; more centralised and 'obtrusive' mechanisms

of control will be adopted; processes of interaction will become more 'rigid' with greater use of formal procedures and extensive documentation; areas of dispute will either remain disputed or be avoided; conflict will characterise the relationship; and the management of work on site will be generally approached much more with a view to 'business system' than to 'technical system' requirements.

The research strategy chosen to investigate these phenomena was to focus attention upon a small number of case studies explored longitudinally, and to rely extensively upon the use of qualitative research techniques (eg Van Maanen 1979). A case study, rather than more broadly-based survey approach was adopted due to the essentially exploratory nature of the research. Given the broad propositions described in the previous section, the concern was as much with identifying the reasons why particular factors may influence processes of interaction in a project setting, and how they may do so, as with establishing the strength of association between particular variables. The very complexity in the variables made explicit in the foregoing, and the likely variety of conditions in practice, put a premium upon taking a more holistic approach towards the study of phenomena in specific instances, rather than separating out individual variables to test more broadly their association across a large sample of cases. Consequently, the aim was to obtain as complete a picture as possible of circumstances and events in just a small number of illustrative cases.

A longitudinal, rather than cross-sectional approach was taken, due to the interest expressed above in the dynamics of the processes involved over time, and the changes in circumstances and events that occurred across each case. It was felt that employing a cross-sectional approach would produce too static a picture of the situation, whereas a central interest in change and development was part of the raison d'etre of the study. Added to this were methodological considerations related to problems of investigation in a situation

defined more by its 'cyclical' pattern of activity. Specifically, adopting a longitudinal approach would assist in lessening the problems associated with attempting to standardise points of entry in order to allow for inter-case comparability, and make for less of a reliance upon retrospective commentary, given the type of information sought. These issues, together with other methodological issues concerning the timing of field research in case studies in situations where the phenomena investigated have a cyclical logic to them, will be returned to in more detail below. The point to emphasise here is that an interest in change and development coupled with significant methodological and pragmatic considerations informed the choice of a longitudinal study, rather than a more static, cross-sectional approach .

An extensive reliance upon qualitative research techniques was predicated upon the types of information being sought, and the methodological implications of adopting a longitudinal, case-study approach. The use of quantitative data in a case study setting is not an epistemological inconsistency (Bryman 1976). However, in this instance, a reliance was placed upon qualitative information due to a number of reasons. Firstly, the type of information sought was highly individualistic. As will be described below, a case 'databank' of information concerning project task and organisational characteristics was obtained for each case. This more 'factual' data was both highly project specific and high in its level of detail. The second broad type of information sought and obtained, was that concerning individuals' own perceptions and attitudes towards the project, its organisation and management. A particular concern here with the respondents' own frames of reference

for the description and interpretation of circumstances and events, placed a premium upon a less rather than more structured ex ante categorisation of possible response sets. The intention was to allow for as full as possible a range of responses in line with the exploratory nature of the research, rather than to inhibit the range of possibilities.

A second reason was due to the comparatively small number of respondents who would be involved relative to the range of variables under investigation. The large number of variables explored in the study and the potential complexity in their interrelationships made a more structured approach to data collection and a more standardised statistical treatment of the data thus obtained an impossibility. This was particularly the case, since the numbers interviewed were to be comparatively small (approximately 10 - 15 in each case). The aim was consequently to obtain data in the form of responses to series' of particular 'themes' with respect to each case (and further to explore these themes more fully in subsequent interviews with the same respondents over time), rather than to employ a set of standardised techniques amenable to rigorous statistical treatment (and perhaps to apply these at later points in the form of a 'panel' design). The onus was upon allowing for the full potential variation in response, such that more open-ended questions for the exploration of particular themes and their development over time became the appropriate means of obtaining the type of data required.

A third, more pragmatic, reason for employing this type of approach was due to the level and type of detail sought in a situation in which full familiarity with the types of circumstances encountered could not

be assumed. An openness to, and awareness of, the peculiarities of the construction process in practice (for instance, technical aspects and legal frameworks) was deemed essential if one were able fully to understand the processes of management found on site in practice. At the same time, it was recognised that the range of possibilities in these respects could not be fully, or perhaps even adequately, specified in advance, given lack of familiarity with the circumstances found in construction. Consequently a reliance upon a more qualitative approach was lent weight by encountering a situation which, compared with other industrial settings (eg manufacturing), has quite distinct characteristics.¹ A strong interest in this study in the centrality of situational conditions predisposed the researcher to pursue a strategy that would allow for investigating as fully as possible the characteristics of those conditions as they were perceived to have influenced the process of management on site, and as they were understood and articulated by those concerned. In other words, an understanding of the full context of social interaction was deemed to be of central importance (Van Maanen 1979, Ch 1).

The broad strategy described above has a number of implications which need to be noted at this point, and which will be referred to again in the more detailed description of the methodology employed in the remainder of this section. Broadly speaking, these concern the issues of the reliability and the validity of the case data obtained. These issues are of central importance to all forms of social and behavioural research. However it is acknowledged that the employment of a strategy such as that described above accentuates the types of problems commonly experienced, and requires a greater degree of attention than might be the case where a more routinised and

standardised research approach is employed.

5.2.1 External Validity

Firstly, the use of case studies severely restricts the extent to which one can generalise the findings obtained to a wider population of which the sample of cases is a part. The problem is of the external validity of the findings. In this study, the projects selected (see below) were not systematically sampled in any way, and consequently no claims are made here as to the representativeness of the sample. At best one might say that the cases studied appeared to be by no means untypical of the types of projects undertaken within the industry. However, this is not to suggest that they are so in any technical, sampling sense. By the same token it is not possible to generalise the findings to the wider population of similar projects undertaken within the industry. The projects have been approached as highly individualistic cases. Indeed, an importance has been attached to allowing for the full individuality of the cases in exploring the phenomena of interest. Consequently, no claims are made concerning the generalisability of the findings to other cases. However, a claim is made as to the broader analytical generalisation of the findings to the propositions investigated. Yin (1984) for example, draws an important contrast between case study and survey research in this respect:

"The external validity problem has been a major barrier in doing case studies. Critics typically state that single cases offer a poor basis for generalising. However, such critics are implicitly contrasting the situation to survey research, where a 'sample' (if selected correctly) readily generalises to a larger

universe. This analogy to samples and universes is incorrect when dealing with case studies. This is because survey research relies on statistical generalisation, whereas case studies (as with experiments) rely on analytical generalisation."

(ibid, p39; emphasis in original)

The author concurs with this view, and recognises the importance of replication (ibid) as a means of strengthening the case for arguing for the external (analytical) validity of the findings obtained.

The method of replication made in this study was in the form of a multiple case design in which a sufficient number of cases were selected such that worthwhile comparisons and contrasts might be drawn between them with respect to the propositions investigated. The analysis is consequently conducted within the bounds of the sample of cases selected; although it is argued that sufficient number of cases were investigated and in sufficient detail to allow for analytical generalisations to be made on the basis of the findings obtained. The use of five cases here explored in great detail created problems in the comparative examination of circumstances and events between projects (and indeed within projects), due to their variation across a substantial number of dimensions. Consequently it should be noted that the comparisons and contrasts drawn have been done so while attempting to allow for the highly idiosyncratic nature of the cases explored at the level of detail that information about them was both sought and obtained. However, in relation to the external validity of the findings, it is argued that the inclusion of five cases allowed sufficient ground for analytical generalisations to be made.

5.2.2 Construct Validity, Internal Validity and Reliability

Important implications stem from the use of an extensive reliance upon qualitative data in this study for ensuring construct validity, internal validity and the reliability of the data obtained (cf Yin 1984, Ch 2). Concerning construct validity, the problem is one of ensuring that correct operational measures for the concepts being studied are established. Concerning internal validity, the problem is one of being able to draw causal inferences. Concerning reliability, the problem is one of ensuring that the operations involved in the study could be repeated with the same results. These issues relate to the methods employed in data collection which are described in more detail below, with attention there being more directly focused upon specific procedures and potential threats to validity and reliability.

With respect to construct validity, a general point to be made is that the study involved a more phenomenological approach of relying upon respondents' own frames of reference in describing the situation on each project, changes and developments over time, and their view of the importance and relevance of specific conditions and changes. As a consequence the measures that were used, insofar as they may strictly be termed 'measures', were highly perceptual, reflecting an interest in obtaining data not only upon attitudes, views and opinions themselves, but also data upon issues as their meaning, salience and importance was defined by those involved. For the collection of the dataset used, use was made of multiple sources of evidence (namely a questionnaire, interviews, documentary evidence and direct observation); and establishing a chain of

evidence relying upon corroboration of data and accounts from different sources and individuals, and the repeat questioning with respect to the development of issues over time (Yin 1984). The type of data collected ranged from the more 'factual' descriptive information concerning the case and its participants, to attitudinal data concerning the attitudes, views, opinions and perceptions of those involved. The importance of this latter type of data made for a careful treatment of the information during the subsequent analysis in order to ensure that the requirements for construct validity were met: in particular in ensuring that the meanings assigned to particular phenomena were consistent with the definitions of the constructs employed in this study.

This issue dovetails with a concern for ensuring the internal validity of the dataset. The issue is not seen as particularly salient for exploratory case studies (Yin 1984, p36). However, in this study an attempt was made to explore to some extent causal relationships between the variables investigated. While the central intention was to explore patterns of association between sets of factors, the question of causality is implicit in a number of the propositions listed earlier. Moreover, a longitudinal approach, coupled with the fact that much of the (attitudinal) data was given directly in the form of (often lengthy and broad) causal statements, meant two things. Firstly, that some opportunity was available for studying the question of causality; secondly, that, in the interpretation of the data, having to confront causal mechanisms that were articulated by the respondents themselves could not be ignored. This is not meant to overstate the importance to the study of drawing causal inferences. Rather it is to acknowledge that the study reported here

was conducted in such a way as to make a consideration of the issue of minimising threats to internal validity an important feature. The issue is related largely to the procedures used in the analysis of the cases, and will be discussed in more detail below. The point to be made here is that the analysis of circumstances and events on each case presented a picture that was based on often variegated (and, of course, often conflicting) accounts, of the same issue. Consequently, an important part of the data collection, presentation and analysis part of the research consisted of an attempt to disentangle the mass of often competing and conflicting claims: bearing in mind the need both to strengthen internal validity, and to allow for valid differences in interpretation. In particular, as will be described below, the presentation involved a considerable effort to develop an explanation of circumstances and changes, based upon the accounts given and also upon a longitudinal, time-series type of analysis in which causal developments over time could be to some extent assessed. Yin (1984) has described three analytic tactics aimed at securing internal validity: pattern matching, explanation-building and time-series analysis. The approach adopted here, given the longitudinal basis of the research, combined elements of the latter two tactics.

Concerning reliability finally, the procedures described below for the collection of more 'factual' case data represent the main mechanisms employed in establishing a case study data base (deemed as a primary tactic for helping to ensure reliability (Yin 1984, p40)). However, it should be recognised that the approach adopted involved a good deal of interdependence between the pattern of questioning and the responses given, particularly since the aim was

to explore circumstances and change over time, and to follow through particular issues as and when they arose. In a sense, the approach adopted in this respect contained elements somewhat closer to a form of 'investigative journalism', in which 'leads' were followed through. While the highly individualistic nature of each project could be recorded in the form of a definitive data base, the highly individualistic train of events largely could not. Nevertheless these aspects were deemed of considerable importance to an understanding of the case as a whole. Consequently in these respects, it is difficult to unambiguously assert the full reliability of the data in the technical sense described earlier, since lines of questioning were developed as circumstances occurred and changed, and a considerable emphasis was put upon the discretion exercised by the researcher in pursuing particular lines of enquiry. Consequently, the implications of this more 'reactive' response need to be set aside the fuller degree of reliability obtained by the collection of data to provide a definitive data base.

As a brief summary, before describing the sample of the cases studied and the methods used in more detail, the author acknowledges the particular problems presented in conducting a research strategy such as that discussed here. However, the author agrees strongly with the views that the employment of such a strategy is particularly appropriate given certain lines of enquiry; that case study/qualitative research has a 'validity' (used in a broader sense) of its own and that efforts to compare it directly with more broadly-based/structured models of enquiry are sometimes erroneous or ill-founded; that the type of research strategy pursued here is not the 'easy option' that it is often depicted as, and should not be taken solely as the 'poor

cousin' of survey/quantitative methods; and that it is important to describe in some depth the methodology employed in order to allow as full an assessment as possible of claims to validity and reliability (eg Yin 1984, Van Maanen 1979). The raisons d'etre of this type of strategy - the richness of detail it yields and the holistic interpretations that are possible - at the same time succeed in being the bêtes noires of researchers in the field. This discussion is aimed at confronting the problems of the latter, in order to ensure the maximisation of gains from the former.

5.3 The Sample of Cases

5.3.1 The Unit of Analysis

As noted a number of times already, the unit of analysis for investigation was taken to be the project itself, rather than the work undertaken by one of the firms involved as part of that project. Given this choice, two significant methodological problems associated with defining the 'boundaries' of investigation need some attention before continuing. The first is in allowing for the variation that occurs in the nature of activity undertaken at different stages in the total project cycle. More specifically, if the aim is to undertake some form of comparative examination between cases, one needs to ensure that a broad basis for comparability in time exists. For the purposes of this study, the 'boundaries' of the project in time were defined as corresponding to the construction period on site only. A good deal of importance was attached to obtaining information and views concerning the situation and developments in it prior to the start of construction activity on site (ie in design and

tendering). This 'prehistory' of the project needed to be investigated as a set of contextual factors, due to their importance in defining the situation and influencing current conditions and developments on site. However, none of the cases investigated were explored at a sufficiently early enough stage for information to be obtained in 'real time' as it were. Instead, the methodological implication was that a good deal of reliance was placed upon key informants' retrospective commentaries. The potential for selective recall, post hoc rationalisation and simply forgetting details, needs therefore to be recognised with respect to the pattern of events prior to the period of central interest here. Similar issues arise with respect to events during the construction process itself prior to the period of fieldwork. These issues will be returned to again below.

The second problem is related to the first, and concerns allowing for what may be highly variable patterns of involvement of members of the 'project team' in the performance and management of work on site. Specifically, it is the problem of inclusion or non-inclusion of participants within the respondent set. A good deal of importance was attached in the study to obtaining information and views concerning the organisational backdrop to the management of the current project in the case of each organisational sub-grouping within the wider project team. In other words, there was a concern with exploring the intraorganisational context of interaction at the operational level, and the impact that broader organisational characteristics and attributes may have had, or be having, upon the conditions observed on site. The approach chosen was to draw the 'boundaries' of the project organisation to include those individuals who were most directly involved in the management of work on site, and

to use them as key informants from whom were obtained data on organisational attributes and practices which had some direct or indirect bearing upon the performance of work on that project. In many cases, this 'focal group' in fact appeared comparatively easy to identify. However, in one or two cases, where circumstances changed as the projects developed, the 'boundaries' of the group changed such that it was necessary to recognise flexibility in the boundaries of investigation to allow for this variation. These changes and their more specific methodological implications will be returned to below. The general point to make here is that, in focusing upon the project as the unit of analysis, one is concentrating upon only a subset of wider organisational activities in the case of each participant organisational group. In the case of research in more stable and static settings (such as manufacturing), taking the individual group, section, department, division or the total organisation as the unit of analysis, means that establishing the boundaries for investigation is less problematic due to the relative consistency of those units' constituents over time. In the case of projects, however, such a degree of consistency is by no means guaranteed. Indeed, if one accepts some of the earlier propositions, one would expect variability in patterns, level and degree of involvement as an empirical likelihood. Consequently there is a need for an approach that recognises this possibility by being responsive to the types of changes that can, and indeed do, occur over time.

5.3.2 The Case Studies: Selection and Access

Five cases for in-depth study were selected as the sample. Each case had in common the fact that it involved the construction of a fairly large-scale project on a 'green field' site. However, the scale of operations and duration of the projects varied, as did the sectoral location (public or private sector), the type of work involved (ie what type of structure), and the contractual system employed. Consequently, there was a considerable degree of variation across the cases according to a number of dimensions. A more detailed comparison and contrast of the cases in these and other respects is given in Chapter 11 below, following the descriptions of the cases in the sample. In terms of the type of contractual system employed, the first four cases reported involved what may be considered to be a 'traditional' form of delivery system in which the design team and main contractor were hired/employed separately by the client.² The fifth case study was of a management contract in which a separate agent was employed to manage only the work on site (see above, Chapter 3). It was intended that a sixth case study would be included - of a design and construct contract (see also Chapter 3). Contacts were made (see below) with a view to undertaking the research on a design and construct contract; and preliminary discussions and, indeed, initial interviews were held with a number of respondents. However, these access negotiations and preliminary interviews occurred only at a very late stage in the course of the fieldwork stage of the research project. Consequently, insufficient time was available for exploring the issues of interest in this type of setting, and in following up events upon the project where access had been negotiated, and where work had only recently begun. As a result, none of the (limited amount of) material

obtained from the interviews held are reported here, and the sample of projects consists only of the five described in Chapters 6 to 10.

The selection of the projects was based essentially upon the access obtained and the agreement to co-operate on the part of all the main participants. Other than the projects being new constructions and sufficiently large in scale, such that a fairly sizeable site management organisation was likely to occur, no parameters were set for the inclusion or exclusion of projects (ie public/private sector, building/civil engineering). Consequently, the selection of the cases was based very largely upon pragmatic considerations: the availability of personal contacts, and the ease of negotiating access and obtaining the agreement of the parties concerned. The process of negotiating access involved in each case establishing personal contact with senior management staff in at least one of the organisations involved; then attending meetings with those staff and perhaps others involved on the project, in order to explain the nature and purpose of the research, and to find out further information about the project and those involved; and then in repeating the process for gaining the co-operation, and agreement to participate, of representatives from the other organisations involved. This procedure for obtaining access and agreement to participate was largely successful: only in one case (which was subsequently dropped from the sample) was the agreement to co-operate on the part of one of the parties not forthcoming. This degree of co-operation on the part of those involved (particularly given the amount of fieldwork involved as described below) was perhaps greater than anticipated, and entirely to the credit of the participants in the study, their interest, enthusiasm (and patience!).

Before continuing, it is important to stress, however, that the procedure for obtaining access varied in one respect between the cases. In the first two cases (the RAW and AFU projects in Chapters 6 and 7) an initial introduction to the project and its participants was obtained via the main contracting organisation; in the third and fourth (the NSS and MTS projects in Chapters 8 and 9) it was via the clients' main design team representatives; in the final case (the PDL project in Chapter 10) it was via one of the larger subcontracting firms that were employed on the project. Because of the nature of the research and, in particular, the focus upon the relationships between the main participating organisations, this pattern of initial introduction may have had an impact upon the perceived position of the observer vis-a-vis one or other of the participating organisations. Strenuous efforts were made to ensure that the neutrality and independence of the researcher vis-a-vis one organisation or the other were fully understood by those involved. Written and verbal statements were made to this effect, as well as the more usual guarantees of confidentiality and anonymity in the use of all reported information and comments. The general candidness of those interviewed and their willingness to co-operate fully and respond to the questions asked suggests that such assurances were accepted and understood. However, it is pertinent to point out that the type of research undertaken here involved a need for a continuing awareness and reiteration of the researcher's neutrality and independence. This will become particularly apparent when the case histories of each project are described in more detail at the end of each case study chapter. As will be noted below, every effort was made to present alternative and often conflicting perceptions and interpretations of events. In a situation in which participants' responses were often informed by the

perception of others' responsibility or 'blame' for the problems that they were facing, a good deal of emphasis was placed upon the researcher's need to maintain a neutral, uncommitted and diplomatic profile.

A further point is that those through whom access was initially gained were allowed the opportunity to select the site themselves, rather than the researcher exercising the choice. (An exception was the final PDL case, in which an example of a management contract was more actively sought as well as being available; similarly with the design and construct project mentioned earlier). Such a potential source of bias is significant if attempts are made to randomly select cases on the basis of a systematic framework for sampling, and if claims for representation are to be made. However, no such claims are argued for here. In the cases researched here, it might be suggested that the projects were selected as exemplary examples of each firm's activities and performance on site. However, with the possible exception of the second (AFU) case, the accounts given and expanded upon in the case descriptions and analyses lend no convincing support to the argument that the researcher was diverted to situations of 'exemplary good practice' where no problems occurred in the management of the project. More importantly, the aim was not to compare or judge conditions in this respect, since a normative framework did not underly the research strategy, and the concern was much more with events and processes and their relationships with outcomes, rather than upon 'judging' the outcomes themselves. Such an intention was articulated while obtaining access, and subsequently in interviews with those involved directly. Consequently 'bias' in this respect is argued to be of little relevance given the research

strategy chosen.

5.3.3 Fieldwork

An important initial point to be noted with respect to the fieldwork undertaken is that the cases differed in the point of entry in time at which they were first investigated, and also in the duration of fieldwork. It is argued here that the longitudinal approach adopted towards the research served to lessen the impact of variation in this respect that may occur in cross-sectional designs - where variation in the point of entry into a situation defined by its 'cyclical' pattern of activity may exacerbate problems of comparability. However, it should be stressed that variability in the point of entry, the timespan of fieldwork and the number of visits to each site did occur. This was largely due to practical difficulties associated with obtaining access to sites at comparable stages of development, and in following through to completion projects whose duration well outlasted the period of time available for fieldwork. The length and timing of the projects studied, together with the period of fieldwork involved on each are given in Figure 5.2 to illustrate the problem. The more general point is that the choice of the project as the unit of analysis causes methodological difficulties due to the time dimension. In the study of phenomena in more stable, permanent conditions (eg manufacturing), such a problem is much less a critical constraint upon methodological options.

More specifically, the research undertaken on the 'RAW' case, which constituted the pilot study, was concentrated in the early stages of its development. Further visits to this site were intended

5.44

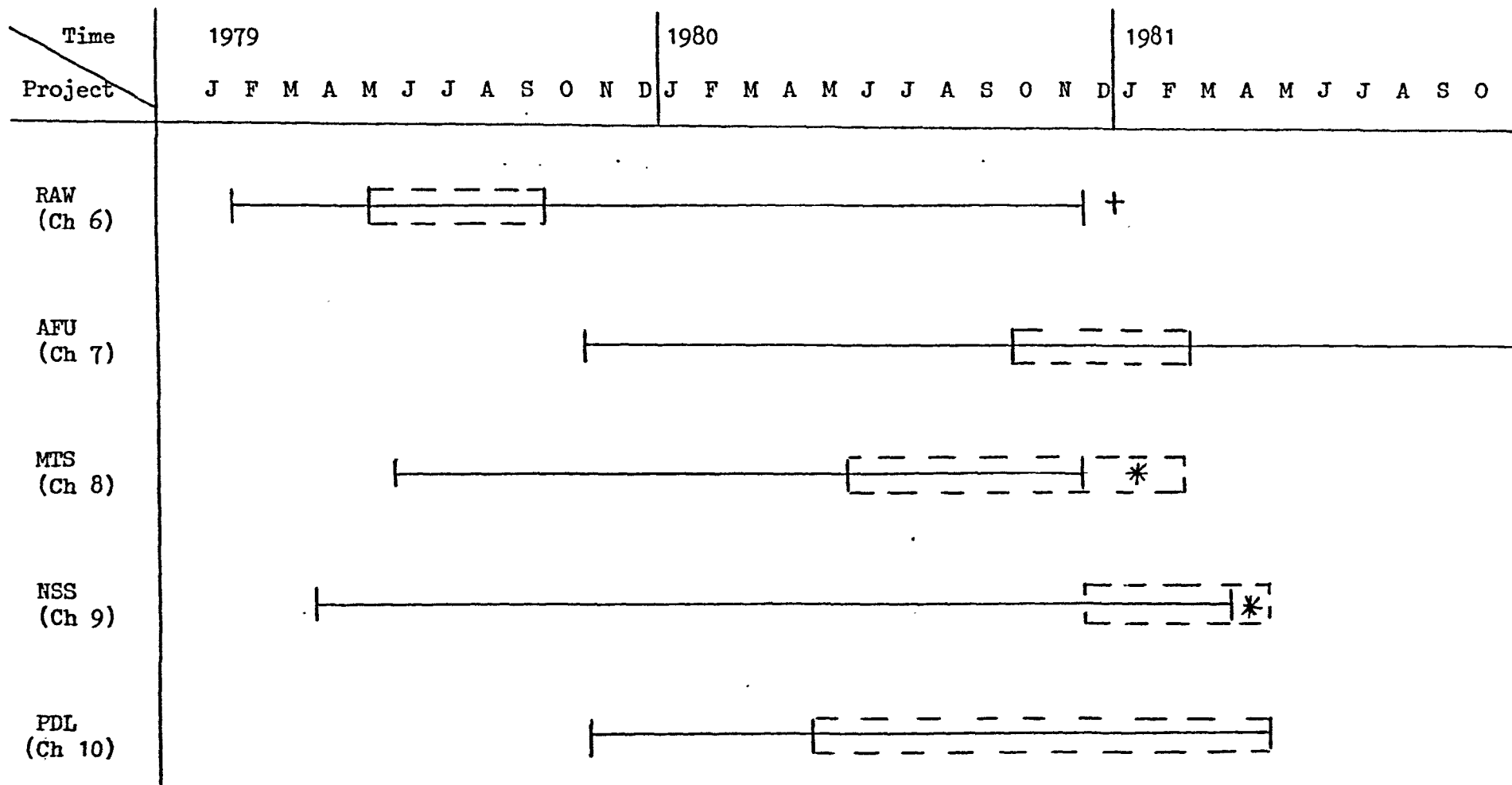

KEY: Project Duration
 Period of Fieldwork
 * Fieldwork continued to actual finish date
 + Fieldwork discontinued due to company liquidation

Figure 5.2 Project Durations and Periods of Fieldwork

as a follow-up during the main period of fieldwork. However, some six months after the last early visit, the company involved on the project was put into liquidation, and no further follow-up visits proved possible. In the AFU case, the lengthy time scale of development meant that access was only available for a period half way through the project's completion. In the remaining three cases, the projects were followed through to eventual final completion, although the period of time available from negotiating access through to final completion varied as can be seen from the diagram. The order of the projects corresponds to the sequence of chapters (6 to 10) used to describe the cases. The chronological order of obtaining access was in fact: RAW (Ch 6), PDL (Ch 10), MTS (Ch 8), AFU (Ch 7) and NSS (Ch 9). The reasons for this shift are given below.

This variety in the pattern of fieldwork raises one or two issues of importance. Firstly, the projects were investigated at different stages in their development with respect to the types of activity undertaken. Details are given in each chapter of the situation at the time of the visits made. The point here is that the data holds only in relation up to and including the time of the final visit. In the RAW and AFU cases, this corresponds to points early on and part way through construction respectively; in the other three cases it corresponds to the project through to its completion. Consequently, the context for the description of events varies between the cases: in the RAW and AFU cases the picture is of a subset of the total construction period, whereas in the other three cases it tends to be a more 'global' perspective of circumstances on site over the entire period. This point is particularly important with respect to performance criteria: in the latter cases, views and opinions were

expressed with regard to performance outcomes that had been realised. As will be seen from the PDL case in particular, quite different pictures of performance were given at early and late stages of the projects development respectively: reflecting the extent to which realised (as opposed to anticipated) performance outcomes informed the views of those involved. In relying upon respondents' frames of reference, one has to be aware of these distinctions and their import for the frames of reference employed.

The longitudinal approach adopted to some extent militated against these effects. However, a second, and related, point is that the case descriptions and accounts varied a good deal in the extent to which retrospective, rather than 'real time' commentary formed a part of the data base. The potential problems of retrospective commentary were noted earlier. What is of particular importance to note here, is that the fieldwork on two of the projects (the MTS and NSS) was timed such that the projects, when first visited, were close to completion. In these cases, not only was a more 'global' perspective on the project as a whole an important frame of reference, but also retrospective commentary (what had happened) was a more important component in responses. In the other three cases, due to a synchronisation of construction and research periods, a fuller opportunity was available for exploring events and change as they occurred, and not as they were subsequently reported. Even here, however, retrospective commentary was an important feature, since in no cases were the very early stages of construction studied. In the description of all the cases studied, references have continually been made to the timing of events and to the framework of response, in order that issues that arose, and views upon them can be 'located'

in the timespan of the project, and in the timespan of fieldwork (or, alternatively, before fieldwork began). However, it should be stressed that the MTS and NSS projects are somewhat different in the extent to which 'global' developments were addressed by the respondents, due to the practical difficulties in being able to achieve a more consistent synchronisation between stage of development and period of fieldwork.

5.4 Methodology

5.4.1 The Programme of Visits

Each site was visited on average once a month during the period of fieldwork for periods lasting anywhere between one and three days. The exception to this pattern of visiting was in the first, pilot case (the RAW project), where two blocks of fieldwork of three and two weeks duration respectively, and where local residence in each case, meant that the opportunity was available for more intensive study and the visiting of the site on a daily basis for quite extensive periods of time. In this case the access given was fully agreed and established in advance, and the site was used as a field base from which interviews with other personnel (eg head office representatives) could be arranged by telephone.

In the other cases, once the principal of access had been agreed, specific visits were arranged in advance by telephone with staff on site. 'Busy' days were avoided, due to the likelihood of people not being available for interview, and a concern on the part of the researcher not to be a potential cause of disruption.

The visits were usually timed to coincide with the dates for formal contractual meetings involving the main participants. Once on site, the main site offices were used as a base from which interviews could be arranged: either by direct personal contact, or by telephone. (It should perhaps be noted at this point that the extensiveness and intensiveness of the fieldwork involved was constrained not so much by the readiness of those involved to participate (which was considerable), but by the limited funding set aside and available to grant holders for pursuing field research of this type. With a more generous allowance for fieldwork provision, it is argued that a more frequent and intensive programme of field research could have been conducted, with obvious benefits for the research study as a whole).

5.4.2 The Participants

Interviews and discussions were held with all those participants on site described in the case study texts, plus representatives from head office organisations where appropriate. There were one or two exceptions to the former rule which are noted in each case description. The many subcontractors involved, and the variation between the cases in the numbers involved at different times posed problems for gaining access to subcontractors' representatives and conducting interviews. In the event, interviews were held with site representatives (eg forman, site agent) from at least two subcontracting firms on each project. In addition, in one or two cases, interviews were held with subcontractors' head office representatives (eg contracts managers) where access was available to the researcher. The information and views given by subcontractors' representatives proved highly useful as a means of obtaining extra detail, cross-checking accounts,

providing corroborative evidence, and as a source of alternative interpretations of events. However, it should be noted that practical limitations meant that the position of all subcontractors vis-a-vis the main parties could not be fully and systematically explored across all the cases. For example, while representatives from the three subcontractors involved in the early stages of the RAW project could be interviewed, in a case such as the PDL project, where the number of subcontractors at any one time averaged 10 to 12, such a degree of coverage was largely impractical. Moreover, at different site visits corresponding to different stages in the work, different subcontractors were involved. Consequently, the transience of subcontractor involvement militated against effective and full coverage across the site. Moreover, referring back to the earlier problem noted of the stage at which the point of entry was made (and the stages covered by the fieldwork), subcontractors' involvement was mostly episodic, and the accounts given specific to certain sections of the work and not necessarily to the situation on the project as a whole. As such, information and views given by subcontractors' representatives were used to corroborate (or not) more general accounts given of the project and its management, and specific examples are given in the case study texts as illustrative of the themes discussed, or of alternative interpretations of events.

The interviews that were conducted reflected a somewhat opportunistic approach. Apart from the initial series of interviews which were arranged with the respondents in advance, and for which a specific time was set aside, later interviews and discussions occurred largely as and when people became available. The interviews conducted thus varied considerably in their length (from ten minutes

to three hours). Also, the intention of 'following through' particular issues meant that, once initial interviews were held, later interviews as the site progressed were held variously with those who were centrally involved and could act as key informants. Consequently, it should be noted that some participants were interviewed more frequently, and for longer periods of time than others, throughout the course of the fieldwork as a whole. This more flexible approach was predicated upon the need to explore change and developments over time, and reflected the different level and nature of involvement of staff at various times. In presenting the case studies below, a particular care has been taken in ensuring that the location in time of events and views expressed is made clear. Care has also been taken to make explicit the greater part played by some participants than others in the description and interpretation of key issues and events. At the same time, it is acknowledged that the approach that was taken cannot fully allow for the potential spread of response in relation to central issues and events. Again the discretion and judgement exercised by the researcher was an important part of the methodological approach pursued.

5.4.3 The Methods Employed

A combination of four methods was employed to obtain the data that was needed. The main methods were: the use of a questionnaire to act as the basis for collecting information concerning the project, the organisations involved, and the patterns and processes of management with respect to that project; and the holding of semi-structured and unstructured interviews with participants to supplement

this information and, more importantly, to elicit responses concerning the attitudes, views and opinions of those involved with respect to the manner in which the project was organised and managed. Use was also made of information available from documentary sources (eg contract documents, company manuals and procedural guides, minutes of meetings, etc) to supplement the more 'factual' material obtained, and to allow for the cross-checking of information obtained from the accounts given. Direct observation, through attendance at meetings on and off site, and more generally in the periods of time available on site between interviews, also served as a useful method: particularly for 'gaining a feel' for the situation and allowing for a greater familiarisation with the procedures and practices that occurred; but also in picking up 'leads' (in the investigative journalism sense) that were worthwhile following up. Field notes were taken from documentary sources and from direct observation that became part of the database for each case study. All the data obtained from these four sources was recorded manually in the form of field notes, and a diary was kept of times of visits, meetings attended, interviews held and issues that arose.

(i) The Questionnaire

A lengthy questionnaire was used in order to obtain detailed information on: the nature of the project; its development during the stages prior to work starting on site; the procedures involved in pre-site design and planning; the roles and relationships between the personnel involved at that stage; the nature of the work being performed on site; the structures of organisation and processes of management involved;

and the roles and relationships among the personnel involved in the management of work on site. The aim was to provide a checklist of information concerning the project, its management, and the roles of those involved to use as a descriptive backdrop to the analysis of the situation and events upon the project during its construction period.

The full questionnaire is attached in Appendix A. It should be noted that the response categories were left open. The intention was to use the questionnaire as a guide for the specific information to be obtained across the case as a whole. It differed in this respect from the type of questionnaire normally employed in field research, in that the intention was to obtain a databank of information about the case as a whole, rather than to obtain responses to specific questions asked of individual respondents. This intention meant also that the questions need not be asked of specific respondents. Those who were asked were used as 'key informants' to provide much of this more 'factual' data concerning the project and its management. Additionally, the examination of documentation and, to some extent, direct observation, allowed for the completion of a checklist of information concerning the project and its management.

It should be noted here that interest was centred upon the actual practices of management that were adopted. As such a good deal of effort was expended in cross-checking details that were given concerning what was actually happening in order to ensure the reliability of the information

given by the respondents. At the same time, any divergencies that emerged between accounts of the same process were not discarded, since they amounted to potentially significant analytical features (ie differences between official, assumed and actual patterns of management). In the event, given the type of information sought via this method, the number of divergencies that occurred in the accounts given were found to be minimal and of little direct analytical significance.

(ii) Semi-Structured Interviews

The information given, and the views and opinions expressed, in interviews held with the participants in each case form the central analytic 'core' of each case study. In these interviews, the focus of attention was largely upon the manner in which the project had been run and managed. Interest was upon the respondents' viewpoints concerning: the role of their own organisation in the running of the job; the types of problems that had been encountered; the characterisation of relationships with other parties involved in the project; the manner in which problems had been resolved (or not) and decisions reached (or not); and their own feelings about their position and role on the project.

The interviews held were semi-structured in form. A schedule of information that was designed to yield supplementary information to that obtained from the questionnaire was used as a guide for the initial stages of the initial interviews, but more as an aide memoire for the researcher, than as a fully

structured set of questions to be specifically asked of each respondent. This has been attached as Appendix B. Questioning in detail about the aspects described above was more loosely-structured, with the intention of allowing as sufficient scope as possible for the respondents to air their views and employ their own frame of reference for describing situations and events. The pressure this type of approach puts upon the researcher's ability to conduct interviews effectively cannot be overstated. The fact that the line of questioning pursued is dependent upon, rather than independent of, the types of responses given puts a premium upon the skills of the researcher in following a line of questioning without being diverted too much from the central issues; and in responding appropriately to the flow of the conversation without hazarding the loss of potentially important information or gaining a mass of interesting but irrelevant information. In conducting these interviews, a broad set of lead-in questions corresponding to the issues noted in the above paragraph were phrased, and the respondent was prompted to give further details and views as it was felt to be appropriate.

Consequently each respondent was asked the same broad set of questions. However, not surprisingly the types of response, the 'themes' identified, and the importance attached to them varied often from respondent to respondent. The accounts reported in the latter part of each case study chapter are given with an acknowledgement here that the issues raised and the views and emphases given varied quite considerably. In some instances,

it should be added, important themes addressed in this study were not always given attention by those interviewed, and deeper prompting failed to generate a response. In those instances, and particularly in instances where corroborative accounts were not given, and where alternative interpretations were made, explicit and detailed attention has been directed towards the issues in the case analyses.

5.5 The Collation, Presentation and Analysis of the Data

5.5.1 Collation

The methodology adopted yielded a mass of information pertaining to each case in the form mainly of field notes. The procedure for collating and 'coding' this data involved establishing an indexing system by which data could be picked out and grouped under relevant specific headings and then combined in the common descriptive format that is described in the next section. The procedure was a lengthy and laborious one, and one fraught with problems in specifying the appropriate 'location' for specific data points. This was particularly so in the case of the less descriptive, more perceptual data; where the idiosyncrasy of events was an appropriate dimension; and where accounts given cross-cutted conceptual lines of enquiry. Every care was taken to ensure that a rigorous and systematic scheme for the collation and presentation of the data was adhered to. However, it should be noted that the idiosyncratic pattern of events on the projects studied marked something of a departure in defining the appropriate logic underlying the description of developments on each project. As noted below,

this material, together with the more perceptual data obtained, is largely withheld until the latter part of each case study chapter.

5.5.2 The Presentation of the Cases

Data from each of the five case studies is presented in Chapters 6 to 10. As noted earlier, the cases are not presented in the chronological order in which contacts with the participating organisations were initially made. The AFU case has been brought forward to stand in comparison with the first (RAW) case which was similar in scale, and similar in being part of a longer-term development. The PDL case has been left till last due to its essential difference from the other four in being run as a management contract.

The names of the projects and the organisations involved have been replaced with pseudonyms in order to ensure the anonymity of those involved and the confidentiality of their views and opinions. A further means of helping to ensure anonymity has been the omission of information on the actual location of the project (the town, city and even region). For the purposes of this study, the location of the project relative to the central establishments of those organisations involved is of some potential interest, and this data has been retained. However, there was no a priori reason for needing information on the absolute geographical location of the projects, other than in the form of information concerning the geophysical conditions on site and the immediate neighbourhood. The only descriptive piece of information that will be given here in this respect is that the sites were located in England.

A further alteration to the data presented has been made in the job titles assigned to those involved. The nomenclature used in the industry presents what can be a confusing picture to those interested in investigating it. For example, the person in charge of the site on behalf of the main contractor may be given any of the titles: Project Manager, Site Agent, Senior Site Agent or Site Manager. The picture is confused further if one considers the synonym 'engineer' for instance. In the first case to be reported, nine engineers were involved on site, together with many at respective head offices. In a civil engineering job, as that one was, the confusion is exacerbated by the tendency to use the nomenclature "the Resident Engineer" to refer to both the particular individual in charge and to the site organisation as a whole: using the term in a generic sense. In that case, it is to be hoped that the presentation given clarifies rather than confuses the picture. In all five cases, attempts have been made to standardise the job titles of the key participants involved to reflect their relative roles, and to ease the process of drawing comparisons and contrasts between cases. At the same time, it should be stressed that this represents only a terminological adjustment and is not meant to reflect an exact comparability in position, influence and status of the respondents compared across the cases within their respective organisations. Indeed, a good deal of the analysis is concerned with addressing the implications of variation in these respects for the observed patterns and processes of project management.

Each case is presented under a series of subheadings which deal with specific aspects of the case. These are:

- (i) The Project, Client and Context: A description of the project, its objectives, the client, and the 'location' of the project with respect to the client's activities as a whole.

- (ii) The Client's Representatives: A description of the design team employed, their relationship to their wider organisation and the client, and the 'location' of the project with respect to their activities more generally.

- (iii) The Main Contractor: A description of the main contractor employed, their size and specialisms, and the 'location' of the project with respect to their activities more generally.

- (iv) The Design Process and Design Organisation: An account of the procedures involved in the design and its management, and the roles of groups and individuals in these processes.

- (v) Characteristics of the Design: An account of factors influencing the design process, and of the nature and extent of the design at the tendering stage and the start of construction.

- (vi) Tendering and the Main Contract: An account of the tendering procedure employed, the selection of the main contractor, and the terms and conditions of main contract established.

- (vii) The Main Contractor's Site Team: An account of the composition of the site team, and its relationship with head office staff.

- (viii) The Client's Supervision: An account of the composition of the team supervising the work on behalf of the client, and their relationship with the wider organisation.

- (ix) The Organisation and Management of Work on Site: A description of the organisation and management of the work, including main contractor, design team and their respective head offices' involvement in planning, co-ordinating and controlling activity.

- (x) Performance: An account of performance levels achieved and the status of the project at the times visited.

- (xi) A Case Analysis: An account of events recorded during the course of activity on site, and their association with performance levels achieved.

It should be noted that this plan of presentation is departed from slightly in the two smaller cases (the MTS and NSS), where the smaller scale of operations meant a much smaller site staff, and a correspondingly less complex picture of the information included under heading (ix). Consequently, in these two cases, that information has been included under heading (vii) instead.

The information contained under headings (i) to (x) was

essentially derived from the descriptive information obtained from the questionnaire, the examination of documentation and supplemented by details given by the respondents in interviews. The information contained in sections (iv) and (vi) needs special attention here, since they involve a reliance primarily upon accounts given retrospectively concerning the 'prehistory' of each project. It is also important to note that the descriptions given under section (ix) are necessarily somewhat static in nature. This point will be returned to below. The bulk of the perceptual data obtained via interviews with those involved is presented under the final section (xi), which is concerned with describing more the pattern of events on the project as viewed by those involved, and the implications of these events for performance and the outcomes achieved. This section is of particular importance in the later analysis and deserves attention here, since it is also methodologically the most problematic, in terms of ensuring the reliability and validity of the data.

The section has been labelled 'A Case Analysis' for two reasons. Firstly, because much of the data presented and discussed therein is in the form of analyses of events made by the respondents themselves. Secondly, because in disentangling the arguments presented as such, and in attempting to create an accurate picture of what occurred in the view of those involved, and to establish whether this was corroborated by others or not, and whether it was a consequence of different and valid interpretations, the investigator is also involved in an analysis of the data. The problem is severe in qualitative research, since the actual 'data' as such often consist of causal statements or inferences as well as holistic views

used to interpret events. This study proved no exception in this respect. It was the disaggregation of multidimensional data, rather than the aggregation of unidimensional variables which proved to be one of the most difficult activities involved in the presentation and analysis of the data here.

In undertaking this task, every effort was made to minimise the threats to validity and reliability that have already been discussed. In particular, conflicting views and interpretations were given equal weighting in the case analyses, in order to present a balanced view that reflected the divergencies in attitude and opinion that were often expressed; and instances in which parties offered 'no comment' on the issue at hand have been noted and recorded. An importance was also attached to the degree of corroboration given. However, sources of (non)corroboration have also been noted, since they arise as points of analytical significance in themselves (eg who corroborates others' viewpoints and why). Taken as a whole, the general interpretation of circumstances and events on each case is that of the researcher, informed by the views and opinions expressed by the participants involved. Every effort has been made to ensure the validity of this interpretation by giving as complete, detailed and accurate a picture as possible in each case.

5.5.3 The Intercase Analysis

As a final set of points in this chapter, a brief summary of the strategy pursued in the subsequent analysis of the data needs to be given. As noted above, the analysis of the data in fact

begins with the presentation of the data itself: the latter section of each case study chapter involves to some extent an intra-case analysis, for the reasons described above. The subsequent inter-case analysis (which also draws upon within-case comparisons and contrasts) is a two-stage procedure. In the first stage (Chapter 11), a broad comparison and contrast between the cases is undertaken, based upon the information contained in sections (i) to (viii) described above. This relates essentially to the descriptive information contained in each case, concerning the project, the organisations involved and the 'pre-history' of the projects. As such it describes the contextual factors of interest to this study, and examines similarities and differences between the projects in these respects.

The second stage of the analysis (in Chapter 12) is centrally concerned with exploring the patterns and processes involved in the organisation and management of each project in the context of the factors described in the previous chapter. Here, the focus of attention is upon the information contained under sections (ix) to (xi) in each case, and an analysis of circumstances and events, taking into account the situation encountered on each project. The analysis in this chapter forms the springboard for the latter discussion (in Chapter 13) of the findings in relation to the propositions stated at the start of this current chapter.

5.5.4 An Illustration of the Methods Employed

Before turning to the cases in detail, an illustrative example can be given of part of the research strategy employed. Figure 5.3 below is given here as an illustration of the procedures involved in the design, manufacture and assembly on site of just one component of the building process as identified using the procedures for data collection described above. The information depicted there pertains only to the information obtained on the managerial functions associated with the performance of the project task (and does not extend to more perceptual data obtained concerning how the firm was organised and run, etc). The firm was a manufacturer and supplier of precast structural concrete units (columns, slabs, external cladding and floors), and was in fact the subcontractor employed in the final PDL case, described more fully in Chapter 10 below. The information that formed the basis for this production flowchart was gathered during a three week period of research at the company's central offices, manufacturing plant and depot, and on a number of their sites. The fieldwork occurred between the final visit to the RAW project and the first visit to the PDL project, and involved the procedures for data collection (questionnaire, documentation study, interview and direct observation) described above.

There is a pertinent set of points to be made here concerning the centrality of the time dimension in this depiction of the firm's activities. Firstly, the chart gives a somewhat static picture of activities. While a flow of activities over time is presented (from project initiation to completion), no attempt has been made to specify the relative time periods involved as one might do, say, in

role: on the one hand, as "the engineer" within the wider project system; on the other hand, as the "organisation's engineer", representing that organisation's interests in external interaction. In terms of patterns of accountability, the picture is complex. The "organisation's engineer" is co-accountable to the organisation's project manager for results on the project, and to the functional head for the use of techniques. Within the wider project organisation, an orientation towards client welfare and loyalty and one's peer group at a professional level suggests a mirror image (albeit less formal) of these internal patterns of accountability. These correspond to the professional's relationships with subgroups within agencies external to the organisation, but to which agencies the organisation has been contracted to provide professional services of some description. The general point to be made here is that, in not fully or clearly differentiating between internal and external processes of interaction within a matrix or project management setting, this potential complexity and its ramifications in terms of patterns of internal co-ordination and control and the role experiences of specialists within the organisation has tended to be missed. Whether such factors emerge and how they do so are, of course, empirical questions. That they are theoretical possibilities due to the nature of the setting is the line of argument that has been pursued here.

The position and role of the 'integrator' or 'project manager' too is here of some significant interest. As noted in Chapter 1, the integrator is seen as the individual who is expected to facilitate processes of joint problem-solving and decision-making and bring wider organisational (project) interests to bear on decisional

employing a 'critical path' method of network analysis. This has been done in recognition of the variety in the projects undertaken in terms of their type, complexity and scale, and the implications they have for the timespan of specific activities.

Secondly, and related to the dynamics of the entire process, a distinction has been drawn between 'routine' and 'non-routine' practices and procedures undertaken. The former refer to those activities necessarily involved in the undertaking of a project. The latter refer to those activities contingent upon variations and changes occurring throughout the course of the 'project cycle'. Thus for instance, changes to the work during the broad stages of design, manufacture and on-site assembly have been illustrated according to what implications these would have for the flow of activity if they were to occur.

Thirdly, the chart describes events on one project only. The firm was, of course, involved in currently undertaking work on a series of projects of different scale and duration. The diagram provides a model of the firm's activities in relation to a specific project in order to give conceptual clarity. However, it should be recognised that such clarity is gained at the expense of not allowing for the complexity of the set of concurrent processes associated with the performance of a variety of projects, located at different temporal stages in the total project cycle.

Finally, a 'smooth', sequentially-related flow of activities between the broad stages of the project (design-manufacture-assembly) is depicted. In practice, however, a greater degree of overlap

between these stages in relation to one project did tend to occur. Excepting the impact of variations and changes (to the design or the programme dates for assembly), internal constraints served to condition what happened in practice. For instance, production runs on one type of unit to be delivered to site may have proceeded while other types of units were still being designed in more detail. Also the costs of storage and double-handling of large units of output presented the need for a more tightly-coupled and integrated flow of operations between manufacture, delivery and assembly.

Given the limitations that these dynamic considerations suggest, some important features emerge if one looks at the interdependencies between the activities involved. The chart has been colour coded to illustrate two important features of the pattern of work organisation and management. Firstly, the pattern of cross-functional interrelationships in the activities performed throughout the project cycle. The diagram is vertically segmented according to the part played by different organisational groupings (ie functional departments) in the project. No attempt has been made here to distinguish fully between sequentially-interdependent and reciprocally-interdependent sets of activities as such. However, it should be clear from the diagram that the susceptibility towards variation and change in the details of the work involved heightens the tendency for relationships involving the latter to be 'activated' during the course of the project. The periods of detailed design/production planning in particular is notable for the extent to which interdepartmental interaction emerges to the fore. The process of assembly on site also illustrates the potential importance of these mechanisms

contingent upon encountering and needing to respond to external constraints and contingencies. The firm was somewhat unusual perhaps in that it specialised in the prefabrication of manufactured system components (assembling, rather than building, on site). Its 'technical core' was the manufacturing system. However, the pattern of interdependencies does illustrate the vulnerability of its technical core to changes in production plans and schedules, and to the degree of cross-functional interaction associated with establishing these production plans and changing them, as conditions and events altered at stages throughout the entire cycle.

Secondly, the pattern of potential dealings with external agencies with respect to the one project has been depicted: both with respect to 'routine' and 'non-routine' activities. As can be seen, these dealings serve as important sources of constraints and contingencies that penetrate 'deep' into the core of the organisation and which include interaction with most of those functional groupings involved in the management of project work. The diagram has simplified the situation by broadly distinguishing between demand-side and supply-side organisations (ie the client, designers, main contractor, and suppliers, subcontractors respectively). It should be borne in mind that the complexity in the pattern of (potential) external dealings is heightened considerably when the variety of these organisations is taken into account. The point to be made here is simply that these patterns of external dealings (to the extent that they are 'activated' in the processes of design, planning, manufacture, delivery and assembly) present the firm with considerable and salient sources of external constraint and contingency in their internal organisation and management of project work.

The foregoing has been presented as illustrative of the processes of managerial interaction explored as a central component in this study on the five cases explored below. The focus on the firm's total activities in relation to one project as the unit of analysis in this example, made the data obtained amenable to the type of presentation given in Figure 5.3. In the five cases to be explored in more detail in this study, such a form of presentation was not possible. This was because the organisational work involved in the management of the project on site was recurrent in nature: that is, the planning and control of work on site was undertaken on a periodic basis (weekly, say, or monthly). Consequently, different sections of the work on site (eg the plastering, the electricians) were managed in the context of an already specified plan of work that set total periods for their execution, and interim targets against which work was monitored. This process of management related to the occurrence of activities across the site as a whole. However, the episodic nature of subsections of the work, and their temporal integration and overlap, meant that it became highly problematic to separate out the management of one section of the work (eg the plastering), if allowance was to be made for the constraints and contingencies in its management suggested by the wide and varying range of other activities being concurrently, or partly concurrently, performed on site. Moreover, the interest was in the management of the site works as a whole. Separating out and focusing upon one particular activity to the exclusion of all else would have simplified the extant complexity and variability in the situation. The above diagram has been given as an illustration of the complexities in the process of project management involved for one organisation, and as an example of the use of the methods employed to obtain some

of the data of importance to this study. The comparable information for each of the five cases investigated is contained in the relevant section which describes the organisation and management of work on site (see above). However, in the cases investigated, the complications that emerge when one takes the time dimension into account has meant that a more appropriate mode of description was found in employing words to describe the situation, and not diagrams. Hopefully, however, the above illustration has given a flavour of the mechanisms of interest, and of the means of exploring those mechanisms employed in this study.

Footnotes

- 1 A more general point here concerns the question of whether the construction situation is 'different' to other types of industrial activity, and with what implications for social science research. Several broad contrasts have already been drawn, and the intention here is not to delve further into the question, other than to note two additional points with methodological implications. Firstly, the construction industry is noted for its comparative absence in studies by social scientists of social and behavioural phenomena in work organisations. Despite the manifest importance of the industry, and its particularly interesting mode of organisation, social scientists, with a few important exceptions (eg Stinchcombe 1959) have rarely sought to make comparisons and contrasts that may allow for a fuller cross-fertilisation of ideas when such similarities and differences in situations are taken into account (eg it was noted earlier that Woodward's research specifically excluded construction firms. It has also been noted that social science studies of project management focus rarely upon mainstream construction project work). One of the consequences has been that social science and construction management research has tended not to dovetail particularly well. Another is that the social scientific research base into phenomena across industries including construction is not sufficiently strong or well developed. It is then difficult to assume that the phenomena of interest are being studied in the full confidence that salient situational conditions (and an understanding of them) are being taken into account. A further methodological implication, discussed below, relates to the mode of investigation in situations characterised by change rather than relative stability and concerns issues of comparability, such as surround the question of entry into the case.
- 2 Under the ICE, JCT and GC/Works/1 (for public sector building works) forms of main contract.

CHAPTER SIX

CASE STUDY: The Riverside Advance Works Project (RAW)

6.1. The Project, Client and Context

This Project involved the construction of the infrastructure of access and drainage facilities required for a new Council housing estate that was to be built by a large Metropolitan Local Authority (the City Council). The volume of work involved was relatively small by civil engineering standards : it consisted of the in situ construction of nine permanent reinforced concrete structures (3 road bridges, 5 footbridges, 1 cycle bridge), the laying of four miles of roadway with pavements and footpaths, and full drainage facilities to serve the planned estate. The site for the works was on formerly unoccupied land bordering a river. It consisted of low-lying marshland which had been reclaimed and consolidated with packed sand 'surcharge'.

The RAW project constituted the first stage of development by the City Council of that site for housing. The second stage, which would follow on after completion of the advance works, would involve the actual construction of (over 300) Council flats. Consequently, while forming part of a housing development programme, the scope of the RAW itself was to include only advance engineering works. The layout and design for this work would be dependent upon the Council's plans for housing on the site. However, the building of the flats themselves was to form a distinct and subsequent stage of the development, undertaken under a separate contract. Some of the work involved on the RAW project was directly related to this subsequent development. In particular, the scope of the contract

was to include the building of temporary works for later use by housing contractors (namely access roads, offices, fencing and a water pumping station). In addition, bulk earthmoving to level the site was involved : this reflected a continuation in the development of the landscape of the site itself.

The site for the RAW project was situated near a number of similar Council house developments that had already been completed and were currently occupied. Indeed, the eventual building of an estate on the RAW site in turn represented only one in a series of such developments. Taken together, these constituted the City Council's "Riverside Programme". This was an extensive programme of Council house building being undertaken within the locality. It had started some 12 years previously, and the aim was eventually to provide accommodation and local services for a projected local population of 50,000. At the time of investigation, about half of that total programme had been completed, and a number of similar estates in close proximity to the RAW site were already occupied. The advance engineering works to be built in the RAW project . similarly represented only a small proportion of the total volume of advance works that would be constructed for the programme as a whole (according to the City Council's official estimates, in the region of 10%).

The City Council was a large public sector client which controlled an annual expenditure on building work in excess of £50 million. While the Riverside Programme as a whole was the largest single current development being undertaken by the Authority, it nevertheless represented a relatively small proportion of turnover on an annual basis, since the estates were constructed individually and in sequence. Indeed, work on the RAW project was the only

advance works contract currently in the process of construction at the time. With an estimated budget of £2 million for the work over a 20 month construction period, the RAW project was relatively small in scale - in relation both to the total programme, and to the volume of construction work being undertaken by the client at that time.

6.2. The Client's Representatives

The work associated with the design and management of the RAW contract - and indeed of the Riverside Programme as a whole - was undertaken entirely in house, within the City Council's own Architectural and Engineering Services Department (AESD). The Department was headed by a County Architect who reported directly to the City Council. The Board of Directors of the Department consisted of the County Architect, the heads of the three architectural branches within the Department (specialising in Education, Housing and 'Special' Works), the Director of the Administration branch and the separate divisional heads for each of the engineering and technical service divisions contained within the Department (see Figure 6.1). The AESD as a whole was a vast organisation, employing directly some 3000 personnel. It handled all the work associated with the design, construction, alteration and maintenance of all the City Council's residential and non-residential buildings, acting on behalf of specific departments (e.g. education, housing) within the Local Authority.

The Riverside Programme as a whole constituted by far the largest single current development being undertaken by the AESD. Indeed, a separate division (the Riverside Division) had been

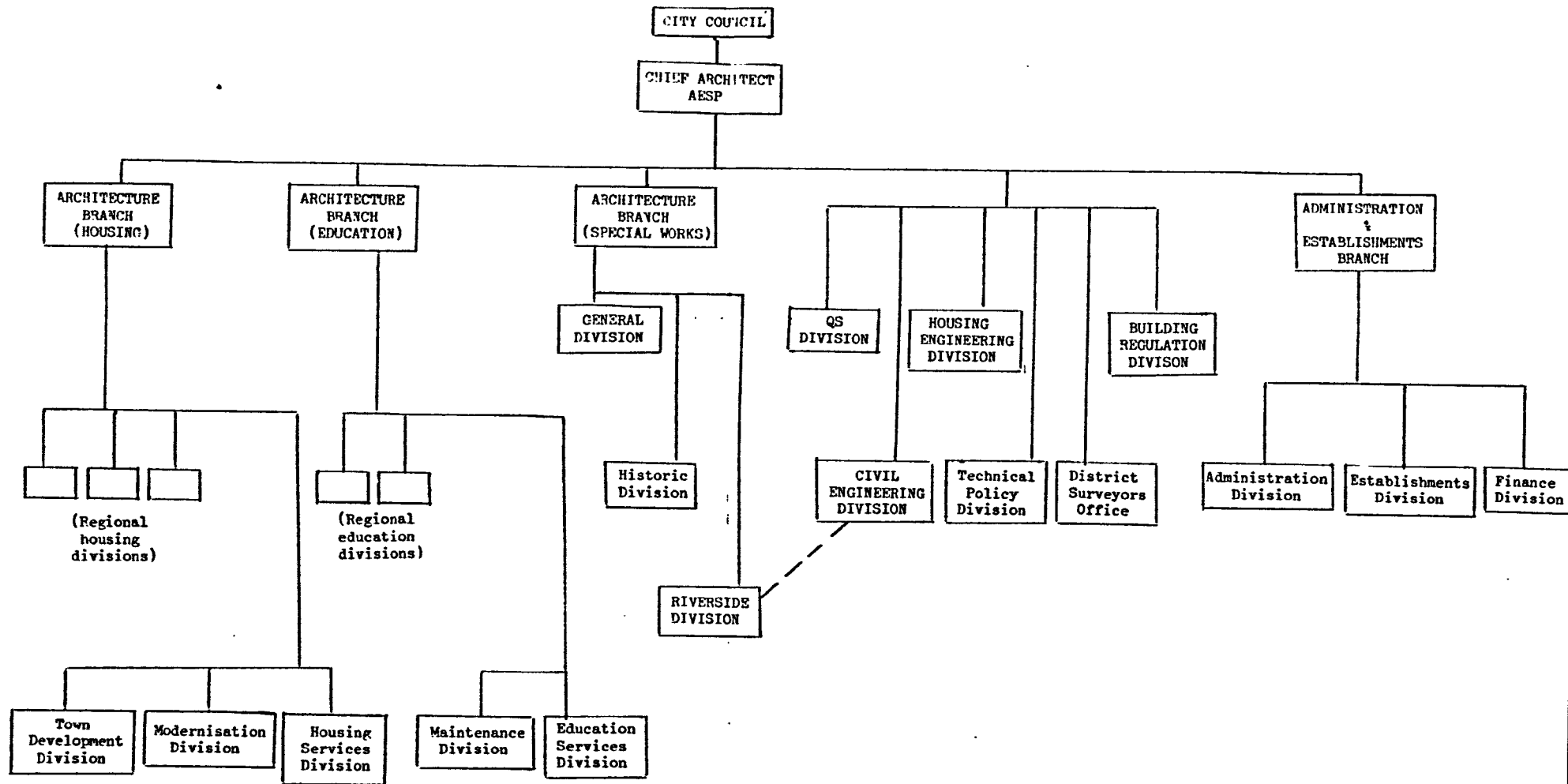

6.4

Figure 6.1 The Architectural and Engineering Services Department

established within the Special Works branch of the AESD to oversee that programme. However, the total advance engineering works for the housing estates was undertaken by a separate Civil Engineering Division within the Department. This Division was one of six 'technical support' divisions established to provide services for the AESD's main 'operational' divisions that were located in the three main architectural branches. In addition it too performed an 'operational' role - involving the design and management of advance engineering work projects, of which the RAW project was the latest example. The Division employed about 80 personnel - consisting in the main of design and construction engineers and technicians. Taken together, the total volume of advance works for the Riverside Programme constituted the Division's largest single continuous programme of works, involving concurrently both design work for future contracts and supervision of existing ones. However, the spread of the Programme's advance works over a number of years, meant that, at any one time, individual Riverside projects comprised only a proportion of the division's total activities. The RAW project itself was small relative to the capacity of the Division, and the type of work involved was similar in many respects to that involved in previous advance projects. As noted earlier, it was the only advance works project in the process of construction at the time of investigation.

6.3. The Main Contractor

The main contract for the construction of the RAW project was let to Roadbuilders Ltd. The company was a private firm registered as a 'marine and public works contractor'. It operated almost exclusively in the one region, and its head office was located

approximately 60 miles from the RAW site. It was a relatively small company, which employed some 500 personnel, about 80 of whom were managerial, technical and administrative staff based permanently at the head office. In the accounting year that fell between the start and finish dates of the RAW contract, its annual turnover approximated £10 million, which compared with the previous year's level of £12 million. Its fixed capital was £2 million and net current assets £250,000. In that year, the firm had experienced a pretax loss of £150,000, compared with a comparable figure in pretax profit the year before.

The firm was therefore relatively small in scale. It specialised in marine and civil engineering works undertaken for public sector clients and, according to senior managers within the firm, tended to concentrate upon competing for 'medium-sized' projects : the RAW project was here quoted as an example. It was also noted, however, that the company had the capacity to undertake larger contracts as main contractor : the company's recent past record had included completion of two large contracts valued at around £10 million. In addition to undertaking work as main contractor, the company also housed its own specialised piling division, which undertook subcontracted piling work for other main contractors. At the time of investigation, the RAW contract was the only work that the company was currently undertaking for the City Council, and it represented their only involvement in the Riverside Programme to date. While the project itself was relatively small in scale, it was a sizeable project in relation to the company's turnover, and indeed was one of the (2) largest projects the company was currently engaged upon as main contractor.

6.4. The Design Process and Design Organisation

The design for the RAW project - like the design for all Riverside advance contracts being undertaken by the Civil Engineering Division - had taken place within the context of the broad and more detailed plans for housing established by architects, planners and surveyors working within design groups in the Riverside Division. Their plans, in effect, provided the 'brief' and outline specification for the design of advance works by engineers working within the Civil Engineering Division. There were two groups within that Division that were established to provide a strategic 'overview' of the Division's advance works programme and to co-ordinate engineering design work within the plans for housing. The 'Master Plan' group was involved in the overall planning and monitoring of the Riverside Programme as a whole in respect of advance works. The 'Operations Group' was a multi-professional group of engineers, architects, programmers and technicians, involved in the planning and design of advance facilities on individual sites based upon architectural specifications for housing. Both groups performed an indirect role in the management of advance contracts - consisting essentially of translating the architectural brief into a plan for advance works and securing approval, the placing of contracts for construction, and the general monitoring of the work in relation to the architectural plans.

Like other (architectural and service) Divisions within the AESD; the Civil Engineering Division was composed of a number of 'groups' (in this case 11; in the rest of the AESD the number of divisional groups ranged from 4 to 7). Each group consisted of a group leader and staff from a similar professional background - rather than being multi-disciplinary groups. Apart from the two groups described above, the Division consisted of groups involved in

specialised work, construction supervision and providing specialist services (see Figure 6.2). A number of these groups of designers and construction engineers specialised exclusively upon the design and supervision of advance works projects for the Riverside Programme.

The work associated specifically with the RAW project was undertaken by one of the two construction groups in the Division, which consisted of a section housing design engineers and technicians, who had prepared the layouts and designs for the project; and a section employing construction engineers, technicians and surveyors, and whose staff were involved in the drawing up of contracts and tendering arrangements, and the direct supervision of work on site. It was from this latter section that site supervisory staff were seconded. Consequently, there was a formal distinction marked within the client's representative organisation between staff involved in design and those directly involved in its implementation on site.

6.5. Characteristics of the Design

To some extent the similarity of the RAW project with earlier developments made for a routinisation of the design process for that project. While the specific plans for the RAW site were based upon a distinct architectural specification for housing and, thereby, a specific layout of the advance works, the type of work to be produced was similar in many respects to the type of work that had been produced in previous advance projects. The scale of the project was also somewhat similar. The characteristics of the ground conditions on the site for the RAW project did have implications for the design of the works to be built on it. In particular, the susceptibility of the site to river flooding had meant the need for an extensive drainage system to be built. Further, the use of sand as the base

6.9

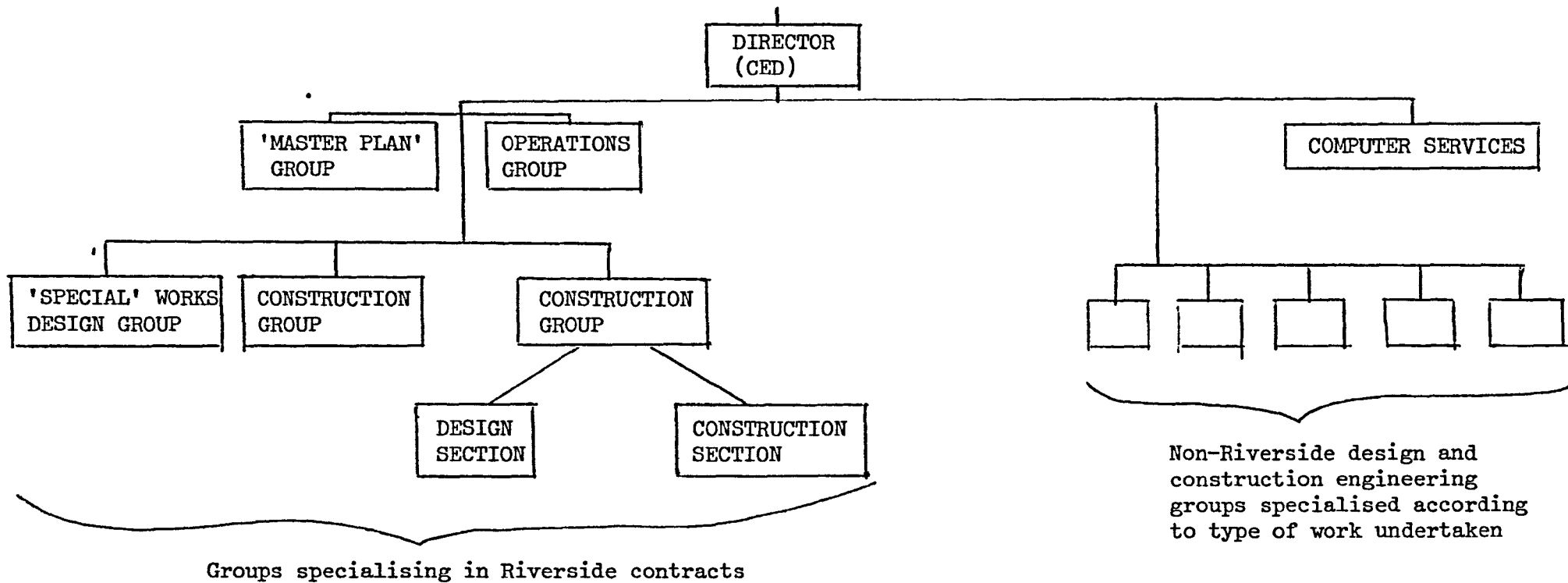

Figure 6.2 The Civil Engineering Division of the AESD

for foundations meant a greater intensity of piled foundations for the drainage system and the structures to provide sufficient stability. However, these factors contributed more to a greater intensity of the work involved, rather than to any fundamental shift in design direction when compared with earlier projects.

There was also very little, if any, design 'overlap' into the construction phase. The design for the works had been prepared over a 4 - 5 year period prior to the award of the main contract, and the documentation for tendering (the bill of quantities, specification and outline drawings) had come available nine months prior to the start of work on site. Representatives of the client who were interviewed on site reported that the design was fully detailed and that the bill contained little in the way of provisional sums - a view that was shared by contractor's staff who were interviewed. Consequently, the design for the works was considered by those involved to be substantially completed. Concurrent design activity during construction would largely be limited to the issue or modification of detailed working drawings, and to the design of temporary works (established by the contractor and subject to the client's approval). Furthermore, the number of variations to the basic design was likely to be low, since the work was 'fixed' in relation to the intended layout for housing. At the stages at which the site was visited, it was agreed by both client's and contractor's representatives that there had been no basic amendments to the overall design of the works, and that there were likely to be few, if any, such changes as the work progressed. Only minor detailing and correction to the drawings were expected. Consequently, there was a fairly clear delineation of the design and construction stages of the RAW project, and attention would be directed towards the actual process of construction of the works, and to performance

in relation to the established design for the works, rather than to any major alterations in the actual design itself. There was also broad agreement amongst staff that were interviewed that the nature of the work, in terms of the methods of building and types of materials that were required did not pose any particularly difficult technological problems. The RAW project was not considered 'complex' in this respect.

6.6. Tendering and the Main Contract

The tendering procedure for the award of the main contract to build the works had involved a single-stage, selective competitive tender on the basis of a priced bill of quantities. According to staff in the Civil Engineering Division, contractors were selected for tender from a shortlist of 'qualified' firms on a 'rotation' basis. That is, the AESD held lists of firms who were capable of undertaking the type and scale of work, against which were set any available ratings of performance from previous City Council projects. The use of 'rotation' was a policy adopted to avoid the placing of too many contracts with too few firms. Given the criteria involved in the selection of firms to tender, the decision to appoint Roadbuilders had been made on the basis of the lowest submitted price.

The main contract was let under standard (ICE) conditions of contract (the 5th Edition), and comprised these conditions together with the bill of quantities, specification and working drawings (both those already prepared and those to be issued during construction). The value of the contract was set at £2 million (with allowance for price fluctuations), and the specified period of construction was 85 weeks (February to November). Work was to be

evaluated, and the issue of interim certificates and payment to the contractor to be made, on a monthly basis with a 5% retention withheld. The period allowed for final measurement and evaluation, the issue of the final certificate and payment was 6 months after the finish of work on site. This corresponded to the length of the defects liability period.

While subcontractors and suppliers that were to be used by Roadbuilders were to be subject to client approval, there were no formal nominations made. All subcontractors were to be employed under standard (ICE) conditions of subcontract, and were to be paid fortnightly, with a 5% retention withheld. To undertake the work, Roadbuilders had taken the decision to sublet most of the work involved. Separate contracts were to be established with 'domestic' subcontractors for the earthmoving, piling installation, fencing, underground drainage, road surfacing and kerbing. The main work to be undertaken directly by the main contractor included the concrete works on the main structures, the laying of access roads and drainage pipework. However, the firm was to use concrete, gullies and pipes and 'hardcore' supplied by other firms, rather than supply directly its own materials.

A programme of works had been submitted by the main contractor as part of the tendering procedure, as a plan for completion of the works within the contractually specified period of 85 weeks. The work was to involve, firstly, the laying of the piled foundations for the drainage system and main structures, followed by the laying of the drainage system and the concurrent erection of the structures. The roadworks were to overlap with this stage, but to constitute mainly the latter part of the programme. The bulk earthmoving was to run in parallel with the construction of the permanent works, but

was to be more heavily concentrated in the earlier stages. This, together with the extensive foundations work that was needed, implied quite a heavy concentration of activity in the earlier stages, much of which was to be associated with ensuring the correct layout of the work.

6.7. The Main Contractor's Site Team

A full-time, resident site team was employed by Roadbuilders to manage the work on the RAW project. The company's senior representative on site was a Site Agent. He reported directly to a visiting Contracts Manager from the firm's head office, who was also currently supervising work on four other company sites in the region. The team on site consisted of supervisory, technical and administrative staff as illustrated below (Figure 6.3). The Site Agent had a background in estimating and considerable years' experience in working for the firm. He described his role on the project as being concerned with its overall management, and in particular, with financial and contractual aspects. His deputy - the Sub-Agent - had a background in engineering, and described his job as being concerned with managing the more detailed production and engineering aspects of the work on site. While the Sub-Agent had worked for the company a number of years as a (site) engineer, he had only recently been appointed to his current position. This was the first project he had managed as Sub-Agent and the Site Agent remarked that he saw his own role as to some extent acting as a "guardian" for the Sub-Agent, making up for the latter's lack of experience in managing contracts. The two were transferred from other company sites, and were the only

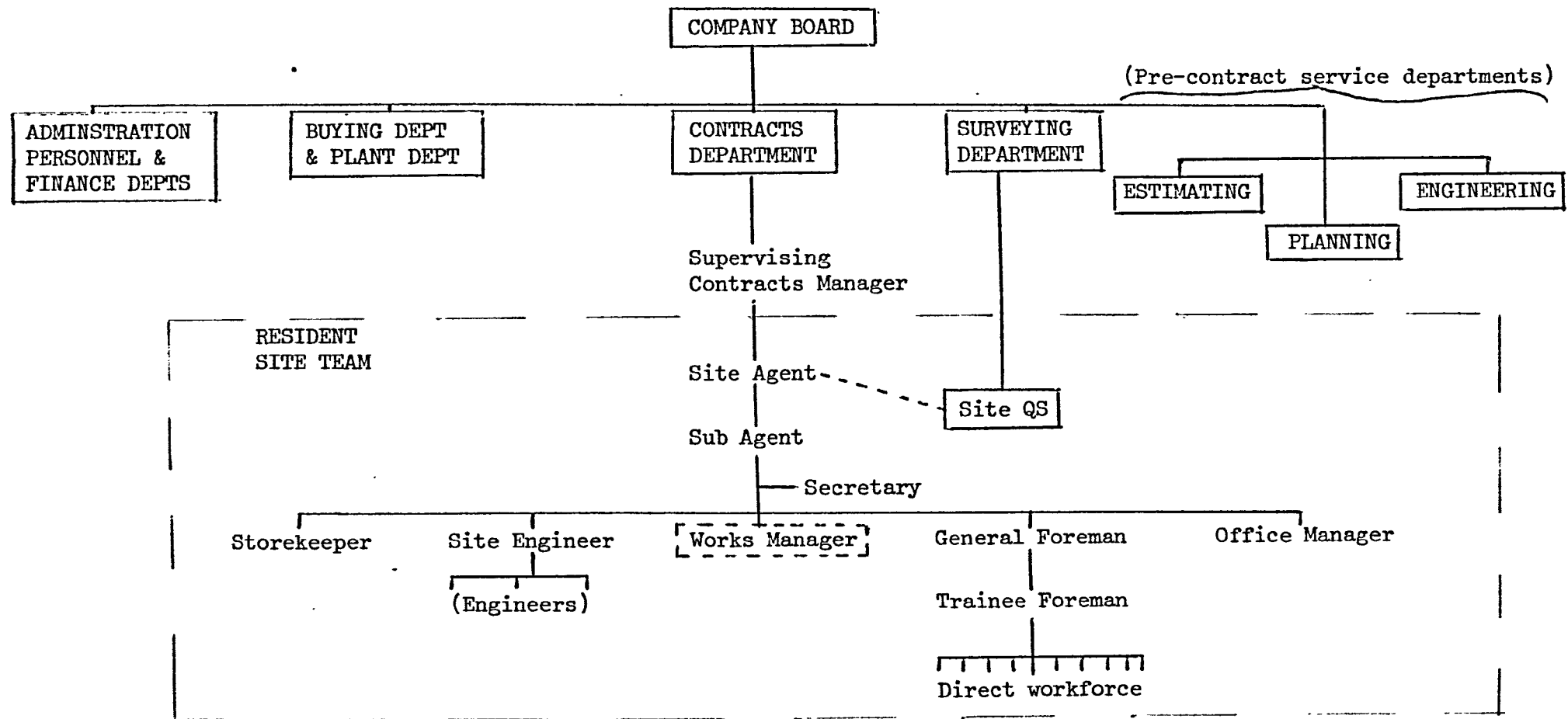

Figure 6.3 Roadbuilders Ltd: Site management team and relationship to head office

members of the site team who had been involved in the project in any way prior to work starting on site. They reported that they had both been involved in familiarising themselves with the project, and in the detailed planning and scheduling of resources needed for the early stages of construction over a two week period at the company's head office. This had been immediately prior to work starting on site.

The supervisory staff (Works Manager, General Foreman) and Office Manager had also been transferred from other company sites, and had considerable years' experience of working in the industry and for that firm. In contrast, the remainder of the site team (with the exception of the QS) were comparatively recent recruits. The engineering staff, in particular, were relative newcomers to the firm : the senior Site Engineer had worked on sites for six years, but had only recently been recruited (by the head office) and specifically to work on this project. His staff consisted of a recent Graduate, a company trainee, and a sandwich student (by the time of the second visit to the site (see below), the Graduate engineer had left and been replaced by an engineer hired through a local agency). Consequently, there was a marked distinction between the production and engineering staff in their level of experience - both of working in the industry and with that particular company. In addition, the Storekeeper and Secretary had been recruited locally (by the Site Agent) and specifically for the RAW project. With the exception of the Works Manager, all those mentioned above were employed for the full duration of the project : the Works Manager was not seconded to the project until approximately a quarter of the way through the contract period.

The contractor's QS was the member of staff whose pattern of involvement on the RAW project was quite distinct. He was seconded to the project twelve weeks into the construction period, and from the head office's Surveying Department (rather than from another company site). He was only employed part-time on the contract, and was not resident on site; his other duties involved the final settling of accounts on another company project elsewhere. The QS described his main job on the RAW project as undertaking the financial measurement and evaluation of the work, and in "advising" the Site Agent on alterations and negotiations. He described his direct involvement with other members of the site team as "minimal". The QS had worked for the company a number of years, and described his own experience as being based mainly on post-contract evaluations, payments and claims, adding that he had not actually worked on site for a number of years, and then not on "so small" a contract as the current one. He expressed the view that the volume of routine measurement and evaluation work involved on this contract was limited due to its size, and described the surveying work involved as being ideal for an inexperienced QS to develop on. He attributed his secondment to this project from head office to the unavailability of suitable surveying staff in the firm at that time.

To undertake the direct work on the contract, Roadbuilders employed a small direct workforce of general labourers, joiners and concrete workers, most of whom were recruited locally (by the General Foreman and Works Manager). In the early stages of the job, the number employed was only five, three of whom were 'chain-boys' assisting the engineer in setting out the work on site. As the work on site developed, the total direct workforce reached a peak of around 20 to undertake the work involved in the building of the main

structures, and for 'attendances' for subcontractors. The total numbers employed by subcontracting firms reached a maximum of around 50 at the same stage in the project.

6.8. The Client's Supervision

The construction of the RAW project was supervised, on behalf of the client, by a site team headed by a Senior Resident Engineer (SRE) and consisting of two Assistant Resident Engineers (AREs), two Design Engineers, a Surveyor, two Clerks of Works and a Secretary (see Figure 6.4 below). The SRE was also involved at the time in supervising four other City Council contracts in the area, but was based on the RAW site. With the exception of himself and the two Design Engineers, all other personnel had been seconded to the site full-time, for its duration, and had been transferred in from other City Council sites.

The SRE had been seconded directly from the construction engineering section of the group in the Civil Engineering Division that had undertaken the pre-site planning work for the RAW. The two engineers were also seconded (full-time) - but from the design section of the same group, in which they had been involved to some extent in the initial design of the works. According to one ARE, this was essentially for training purposes : to supplement design office experience with on-site experience. By the time work on the site was about 25% complete it was noted that one Design Engineer had left the resident site staff. According to the ARE it made little difference to the capacity of the site team to supervise the work, and he expressed the opinion that the site had formerly been overmanned with Resident Engineers' staff anyway.

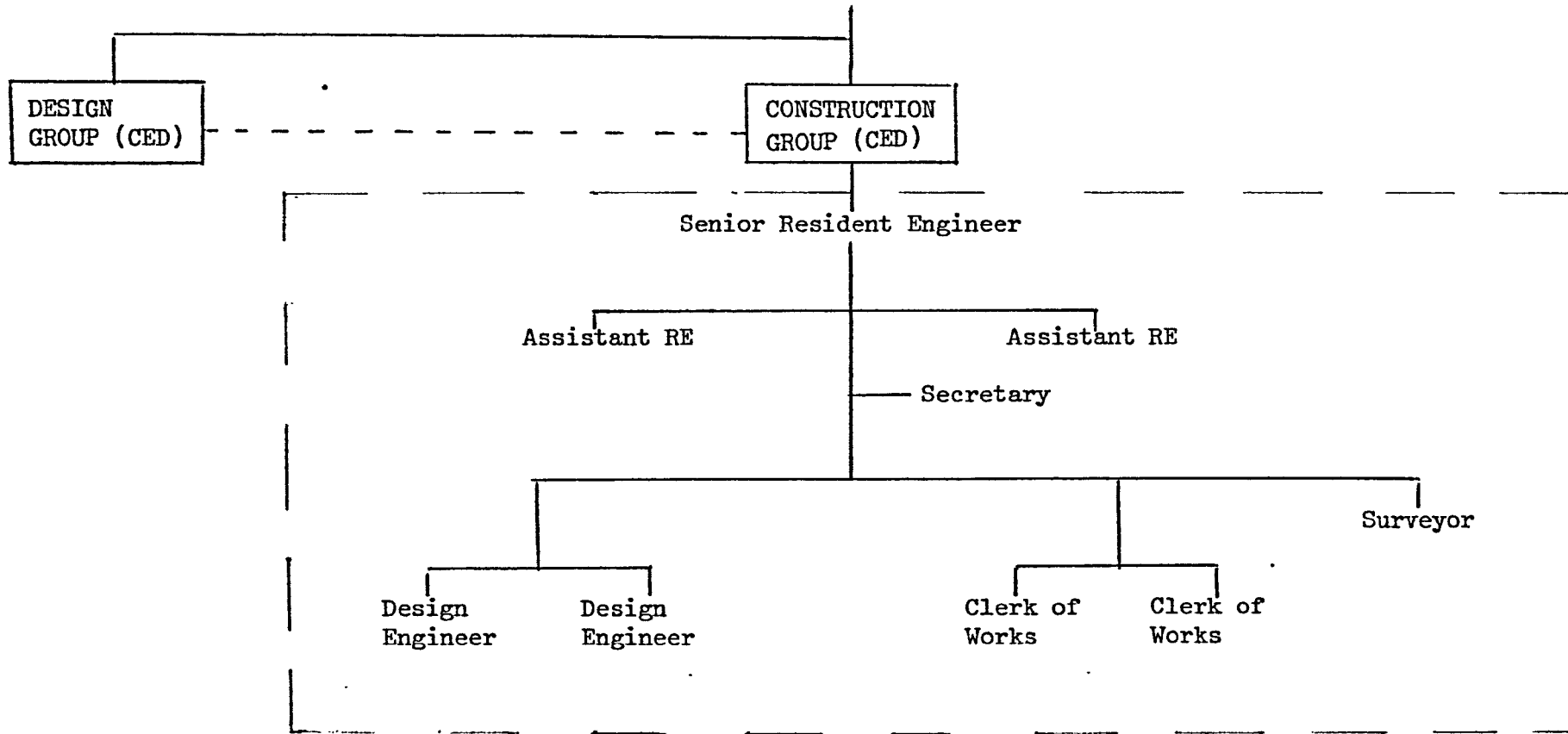

Figure 6.4 The client's project management team on the RAW project, and relationship to 'head office'

The ARE further expressed the view that he found the SRE's residence on this site unusual, since the contract was 'too small' to warrant his presence, and also noted that he assumed the original intention had been that the SRE was "not supposed to be running the job". When asked about this, the SRE attributed his residence to the practicality of having a 'local base' from which to supervise the contracts that fell within his jurisdiction, and also to what he described as the relative "inexperience" of his staff.

6.8. The Organisation and Management of Construction

As noted above, the contractor's Site Agent and Sub-Agent had been involved in a brief period prior to construction in planning out in detail the work associated with setting up the site and the early stages of construction. In addition, prior to this, many of the early and major subcontracts (e.g. for piling and earthmoving) together with major supply orders (e.g. for steelwork and concrete) had already been let. This had involved the contractor's head office Engineer who had supplied the appropriate technical information, and the company Buyer who had conducted the tendering arrangements and formally placed the orders with successful bidders. In these instances, the site team were then involved in agreeing or negotiating detailed plans of work with subcontractors' representatives on site, and in requisitioning materials as work proceeded set against the bulk orders that had already been placed. Where subcontracts or supply orders had not already been placed (as was the case for the kerbing work, for instance, which was subcontracted later on in the project), the site team were also involved in the forward planning

for the work based on the start and finish dates given in the overall programme, and in then appointing firms to undertake the relevant work, or supply the materials needed. Where new sub-contracts were to be let, allowance needed to be given for the lead-in times associated with the tendering and detailed planning stages involved before work could begin on site. The appointments that were made, and the substantive content of the agreements as they affected the design for the works (i.e. the specification for permanent materials, and subcontractors' proposed methods of building) were to be subject to the approval of the client's representatives supervising the work. For the RAW project, the tendering arrangements for new subcontracts and supply orders were conducted from site, involving the Site Agent, Sub-Agent and the contractor's QS. According to them, decisions on appointments were made at site level, although formal approval for the decisions made had to be given by the company's Buyer (concerning the cost) and Engineer (concerning methods and materials) before the orders were actually placed. The processes of placing the awards and administering the contracts (including making payments) were handled at head office level, on the basis of information forwarded from site. Consequently, the main contractor's head office staff performed a largely administrative function in managing subcontractors' work during the course of construction. According to members of the site team, only major 'exceptions' (such as claims) were likely to be referred up to head office level, and all the correspondence and negotiations with subcontractors (and suppliers) concerning the substantive content of the agreement (programmes of work, resources and methods) were dealt with on site once particular subcontractors had been appointed to the job. It was the contractor's Sub-Agent who was most directly

involved in the detailed management of subcontractors' operations on site. The Site Agent, it was generally reported, became more directly involved in this process (with the QS) in the event that issues that arose on site in dealings with subcontractors or suppliers had financial or 'contractual' implications.

Given that subcontract and supply orders had already been placed, the detailed management of work on site was then based upon a series of medium- and short-term programmes of activity that were established as work proceeded. These were derived from the overall contract programme that had been prepared by the contractor's head office Planner, and accepted by the client, during tendering. A monthly 'works programme' was established for work across the entire site, which represented the medium-term plan of work, and which formed the basis from which detailed design information was requested from the client, and resources could be ordered and delivered to the site. It was the Sub-Agent who drew up the programme, which took account of the planned duration and sequence of specific aspects of the work (such as the piling), their interdependencies with other aspects (such as the programme for the main structures construction), and current performance levels achieved on site. The programme was in the form of a bar chart, and formed the basis against which performance on site was monitored.

The monthly works programme was submitted to the client's staff for approval and, once approved, it formed the basis from which weekly (and from these, more detailed daily) schedules of work across the site were derived. These programmes in turn were translated into weekly programmes of work which were then issued to the subcontractors who were performing the work on site. The Sub-Agent drew up the weekly programmes of work together with the Site Engineer and

production staff, who were the members of staff most closely involved in the day-to-day supervision of the job, and who supplied the daily output reports and general information on progress (both in relation to directly-produced and subcontracted work) that fed back into the weekly planning process. Copies of the weekly programmes for work across the site were sent by the Sub-Agent to the client's staff and the contractor's own head office, together with weekly progress reports that were compiled on the basis of the information supplied by the production staff and Site Engineer. The day-to-day supervision of both the main contractor's own, and subcontractors' work on site was the main task of the contractor's Works Manager and General Foreman. They supervised the work being undertaken by the direct labour gang, and handled the recruitment of labour to the site. During the early stages of the project, before the Works Manager was seconded, it was the General Foreman (and his trainee) who supervised work across the entire site. With the secondment of the Works Manager to the project, an extra level of supervision was introduced into the site organisation, and it was reported that the General Foreman then tended to supervise the work of the (expanded) direct labour gang, while the Works Manager supervised directly-produced and subcontracted work across the site as a whole.

A concurrent set of activities were associated with planning out the details of the work to be constructed on site. Once detailed working drawings from the client's staff became available, the contractor's Site Engineer and his staff were involved in checking the drawings, and in establishing any details concerning the methods of building that were to be used by the main contractor. The actual methods of building used followed, in large parts, from the broader method statement and preliminary designs (for the temporary works)

that had been prepared by the contractor's head office Engineer, and accepted by the client, during tendering. On site, the main work in this respect was associated with the detailed design of the temporary works being used by the contractor (notably the formwork needed for the main structures), and with planning the detailed layout of the works (for instance the location of piles and their sequence of construction). For the work produced by subcontractors, the main contractor's staff were involved in passing on relevant design information, and agreeing methods of building with them. Both temporary works designs and methods of building proposed by the main contractor for their own work, and those agreed with subcontractors, were to be submitted to the client's staff for approval. The contractor's Site Engineer (and his staff) were then involved in setting out lines and levels on site for subcontractors and the contractor's own team to perform to, and in supervising and monitoring the work produced in line with the 'quality' standards described in the contract specification and drawings. It was noted that the Site Engineer was also made responsible for making sure that permanent materials needed for the work directly produced by the main contractor (e.g. steelwork and concrete for the main structures) was delivered to the site in time for when it was needed and 'checked' in terms of its quality once delivered to site.

The Sub-Agent's involvement in these activities was at a more general level : he was involved with the engineer in establishing details of methods that were to be used, and in translating the client's working drawings into a more detailed specification for the building of the temporary works. He also became more closely and directly involved in these processes when problems or

'exceptions' occurred - either with inconsistencies or changes in the detailed plans, or when problems occurred in the setting out or building of the work. In these instances, the Sub-Agent would deal directly with his counterparts within the client's team (see below), and with subcontractors' representatives on site. At the same time, however, it was also noted that, in many instances, the clarification of specific design details and methods involved the Site Engineer in direct contact with members of the client's staff on site and individual subcontractor foremen. This was particularly the case when it came to setting out the work for subcontractors to build to, and in directly supervising their work, as well as when supervising the temporary and permanent works being built by the main contractor, which were also directly supervised by the client's representatives.

For the work that was being produced directly by the main contractor, plant and materials resources needed were obtained by a requisition procedure that involved ordering materials deliveries (against the bulk orders placed with suppliers) and plant (from the company depot) to suit the monthly and weekly programmes of work. The new orders that needed to be placed during the course of construction referred mainly to materials needed during its later stages, to temporary materials, and to smaller items of plant and equipment (e.g. handtools). For the direct provision of plant, equipment and temporary materials, the company's formal procedures marked a distinction between small items (costing less than £100) which could be purchased or hired locally by the site team, and any larger items, which had to be requisitioned from head office, via the Buying Department. The decision then whether to supply existing plant, purchase new stock, or hire plant was then made by the company Buyer, although only for large items (over £2000) was the

hiring option made available. Under the firm's accounting procedures, the site was credited or debited respectively with the recovery value or charge rate of the supplied stock. All permanent materials to be used were requisitioned via the Buying Department, against the orders already placed at head office. The types of resources to be supplied in the case of permanent materials followed from the design specification for the works, and the quality of the materials delivered to site was to be subject to the approval of the client's representatives.

The resourcing of the work that was directly produced by the main contractor was an activity in which various members of the site team played a part. The Sub-Agent was the person on site who was given the authority to place major requisitions for materials and plant via head office, and to place orders for smaller items of plant and equipment that were purchased or hired from local suppliers. However, it was also noted that, in practice, the requisitioning of recurrent items (such as concrete deliveries), and minor items (for instance small tools and equipment) was undertaken on a routine basis directly by the production staff and Site Engineer. The latter was particularly involved in this respect in putting in requisitions for recurrent deliveries of permanent materials, as noted above; the former were more closely involved in putting in requisitions and orders for items of plant and equipment that were needed on site. In these instances, the Sub-Agent effectively 'rubber-stamped' requisitions and orders submitted by the production and engineering staff, giving approval to the decisions they had already made on the basis of short-term operational needs.

In directly managing operations on site, the Sub-Agent was involved in generally supervising and co-ordinating the work done by the production and engineering staff, who were the individuals

most closely involved in the day-to-day planning and supervision of directly-produced and subcontracted work on site. As described above, there was some degree of overlap in the roles performed by these members of staff, particularly in relation to ordering materials and directly supervising the construction of the work. They held weekly in-house co-ordination meetings that were intended to plan out the work to be done by each group in advance, which included assessing the resources needed to be ordered for the week, and any outstanding detailed design information that was needed to perform the work. It was noted that the Sub-Agent tended not to be involved in these meetings.

Generally speaking, there was quite a clear distinction on site between the roles performed by the main contractor's Site Agent and Sub-Agent in the management of the RAW project. Namely, it was the Sub-Agent who was most closely involved in managing and co-ordinating the actual construction process across the site, while the Site Agent was concerned more directly with the contractual aspects of the work on site (in which the QS was also involved). It was generally agreed amongst members of the site team that the Site Agent only tended to become directly involved in detailed operational management in situations in which problems that occurred in the programming, detailing or resourcing of the work had financial or contractual implications and involved negotiations with the client's staff or subcontractors' representatives on site. Otherwise, the main functions performed by the Site Agent were in placing new subcontract and supply orders, and in generally monitoring the financial progress of the work on site, based upon the QS's measurement and evaluation of the main contractor's and subcontractors' work on site.

In describing the role performed by head office staff in the management of work on the RAW project, the site staff were in general agreement that they were given a relatively 'free hand' in conducting operations on site. This was attributed in large measure to the presence of senior staff on site. The Sub-Agent, for instance, described head office as a "back-up", providing services and support when they were needed and requested from site. This was in accord with a view of the head office's managerial role expressed by the Planner : he described head office's role as being concerned with monitoring progress on the job and "assisting" and "advising" the site team - if necessary "approving" decisions, but not "instructing" the site staff. Apart from the formal procedures established for monitoring work on the project (involving the receipt of progress reports, copies of all correspondence and instructions passing between the client, contractor and subcontractors, and financial information), and the activities associated with resourcing the work described earlier, progress on site was generally monitored by a series of visits to the site - on a weekly basis by the supervising Contracts Manager, and less frequently and in response to specific issues arising by the office Engineer, Planner and Surveyor. As will be described later, a greater degree of involvement of head office staff through more frequent visits (notably by the Planner) did occur about a third of the way through the contract period in response to a major slippage in the programme that threatened the final completion date. Otherwise, however, the more routine management of the project was decentralised to the site level. The detailed plans and programmes of activity that were established for the work were agreed or negotiated with the subcontractors' representatives on site, and were to be accepted or approved by the client's staff. There was general agreement on

site that any non-major alterations in these respects requiring agreement, approval or negotiation were handled on site by the Site Agent and Sub-Agent, and did not require approval from higher levels within the firm. Consequently, the site team had a good deal of discretion in managing relationships on site with other parties involved in the contract.

The direct supervision of work on site involved a good deal of contact between members of the respective teams on a daily basis. Within the client's team on site, it was the two AREs who were most closely involved in checking the contractors plans for the work and in directly monitoring the job's progress on site. They were the direct point of contact for the Sub-Agent in discussing and agreeing any detailed operational changes to the programme or plan of work on site. They issued the working drawings to the contractor's staff, (which were mainly produced by the two design engineers seconded to the project). The AREs were also directly involved in checking the quality of materials and any proposed methods of building and temporary works designs submitted by the contractor (or by subcontractors via the contractor). However, it was the SRE who formally approved the contractor's programmes and designs for the work, and who issued all formal instructions to the contractor and accepted the contractor's recommendations for subcontractor and major supplier appointments. In describing their pattern of involvement in the detailed planning of work on site, the AREs pointed to a contrast between the expected and formal pattern of their involvement in checking designs and what actually happened in practice. Specifically, they noted that the contractor's engineers were formally responsible for noting any inconsistencies in the specification or drawings and reporting these to the Resident

Engineer's staff. The procedure would then be for the AREs to correct the drawings and reissue them with an instruction to the contractor. However, in practice, they suggested that the tendency instead was for them to become more directly involved in checking the design themselves.

The setting out and actual construction of the work on site was also monitored by the AREs, both directly and on the basis of weekly reports submitted by the Clerks of Works who actually supervised the construction on site, and who reported back to the AREs on a daily basis if any problems occurred in setting out or construction. It was interesting to note here a further contrast between the formal and extant patterns of involvement, specifically in relation to the supervising subcontractors' work on site. The AREs suggested that the "normal" procedure was for them to work "through" the main contractor to the subcontractors. However, when problems occurred in the setting out or construction of the work (as described in more detail below), the tendency was for this channel to be circumvented, and for the AREs and Clerks of Works to directly check subcontractors' work. The AREs suggested that this was "not really their job", and was a role that would ordinarily be performed by the contractor's production and engineering staff.

It was generally agreed by those interviewed in the client's team that the level at which most problems tended to be dealt with on site was at the ARE - Sub-Agent level between the two groups of representatives. At the same time, however, it was reported that problems that occurred with a financial or 'contractual' dimension would, on both sides tend to involve the organisation's senior representatives - specifically the SRE and Site Agent.

According to the AREs, the involvement of the SRE tended to be in issuing formal instructions to the contractor, and in response to any problems in the plans for the work or its construction with financial or contractual implications.

It was also generally agreed that the client's site team operated with a high level of autonomy from their own central office (i.e. the Civil Engineering Division). The SRE stated that he had been given the authority to authorise any changes to the work that were not "substantial". The relationship with the central office consisted in the main of transmitting progress reports, details of any alterations or negotiations, and certificates authorising payment to the contractor. Again the central office, according to the SRE and AREs, provided 'back up' administration and support services : for instance, the formal settling of accounts and payment, any offsite materials testing or advice on methods that were needed, and the general administration of site staff salaries and wages.

The main formal forum for monitoring progress on site was a regular weekly contract meeting held on site. It was attended by the SRE, the AREs, the QS and Clerks of Works on behalf of the client, and by the Site Agent and the Sub-Agent on behalf of the main contractor. At this meeting, the contractor presented a (weekly) report on progress, set against the agreed monthly programme of works, and the Clerks of Works' own summary of progress on site. Other items on the agenda included the contractor's requests for information and drawings from the client's staff, details of subcontract and supply orders placed and the checking of advance orders, plant and labour resource usage on site, and general items stemming from inspections of the works, etc. The details of the meeting were minuted and copies sent to the client's and contractor's respective head offices.

6.10 Performance on the RAW Project

At the start of the first occasion when the site was visited (see Chapter 5 above), the site had only recently been set up, and work was being undertaken by three separate sub-contractors on the piling, earthmoving and perimeter fencing work. Overall progress on the contract was estimated (by both client and contractors' staff) to be approximately a week ahead of schedule. The fencing work was behind schedule, although that activity was not 'critical' to the job as a whole. The earthmoving and excavation work was on schedule. The critical work of piling - for which only one rig was employed by the sub-contractor - was estimated to be about four weeks ahead of the schedule for the drainage system work. By the last week of the first visit, the drainage system piling was completed, and work had started on the foundations for the main structures. However, during the course of that week, progress on piling slowed considerably from a previous average of 30 piles driven a day, to only 3. This was attributed by those involved in its supervision to the loss of the crane driver employed by the sub-contractor.

By the time of the second visit (starting week 30), the piling and earthmoving work was finished, and the emphasis had turned to the construction - in sequence - of the main structures, of which two by then had been built. For this the direct workforce employed by Road Builders Ltd had risen to the expected maximum for the project of 20 joiners, concrete workers and general labourers. Work was also in progress on the installation of the main drainage system and the laying of one roadway by separate

subcontractors.

However, by that stage, overall progress had fallen an estimated one month behind the original contract programme. The delay was attributed mainly to a shortfall in progress by the subcontractor employed to install the main drainage system. It was estimated by the Sub-Agent that this work - which was scheduled to last six months - was now four months behind schedule, and that it had now 'gone critical'. The target completion date was viewed as no longer realistic, and consequently the master programme had been modified substantially (by the company Planner) to try to account for the delay and allow for an acceleration in the drainage work to achieve the contract completion date. Both contractors' and clients' staff attributed the delay to the performance of the subcontractor. However, the opinion was also expressed (by the resident engineer's staff) that the contractor had experienced problems initially in obtaining an appropriate contractor, and that the original plan had been somewhat 'unrealistic' and ambitious.

There was general agreement amongst those interviewed that, at this stage, the main contractor was faced with significant problems in achieving the performance levels required on site to keep the job on programme. In addition, apart from the damages that would be incurred if completion were delayed, it was also noted that at that time the main contractor was incurring additional costs and penalties associated with other, non-critical delays. Firstly, 3 - 4 weeks of delay had been caused by the supply of manhole rings which had been rejected by the resident engineer.

The Site Agent reported that Roadbuilders had not up to then been able to claim back the full cost of the supplies already bought and paid for. Secondly, the 20 week task of constructing a temporary pumping station had been delayed by 4 months, and the contractor was incurring a weekly penalty of £100 for failing to comply with the terms of the contract that had specified a completion date for this work. The delay was attributed to problems in obtaining approval for the contractor's plan for the work from the local electricity authority. Additionally, it was reported by the resident engineer's staff that the contractor's monthly evaluation of the work was a month late, and that the contractor was also behind in its (fortnightly) payments to subcontractors. The money was available for payment to the contractor, but no evaluation had been made and no claim for payment submitted. The ARE suggested that a contract of this type "should be sewn up at a profit", but that "it hasn't really got going yet". Consequently the main contractor was also experiencing financial problems on the project - problems that, according to the ARE, were enhancing "any liquidity problems" the firm might be experiencing.

Indeed the firm was experiencing financial problems at the time which were not, however, specific to the RAW project. Towards the end of the second visit to the site (in week 31 of the contract programme), the contractor's staff reported a "shake-up" at their head office and a "purge" of senior surveying staff, including the surveyor seconded to the RAW project team. No specific reason was given by members of the contractor's staff for these particular dismissals, except insofar as they were a response by the company to a major cash-flow crisis across the

range of the company's operations. The ARE afforded a final commentary upon the performance on the RAW project at that stage, by expressing the view that the main contractor would "probably be bankrupt by Christmas". His words proved prophetic: within six months after the end of the second visit to the site, Roadbuilders had been put into voluntary liquidation and the involvement of the firm in the RAW project had come to an end within a year of the work starting on site, and some 8 - 9 months before completion was due. As described in the earlier Chapter, it was intended to visit at a later stage in the course of work on site. However, in the circumstances this was not possible and the following discussion relates only to the development of the project up to and including week 31 (two-thirds through the construction cycle). It should also be stressed that the following discussion pertains only to characteristics of the management and organisation of work upon the RAW project, and not to the circumstances leading to the problems within the firm as a whole. However, the situation within the firm should be borne in mind as an important contextual factor in the discussion that follows. It was stressed by those interviewed that the problems facing the company were not unique to the RAW project, and not an outcome of performance solely on that project. Rather, the problems of the RAW project were viewed as part of a larger crisis within the firm, and symptomatic of the company's problems at that time.

6.11. The RAW Project: A Case Analysis

During the course of the second visit to the project,

attention was drawn to significant internal problems within the main contractor's team that accompanied the performance levels achieved on site. The recently-seconded Works Manager was the most critical: he described the site as the "worst organised" he had been on in a number of years, and attributed the problems now faced by Roadbuilders on the contract to "a planning and management failure". While he, like others interviewed attributed the main delay problem to a "lack of planning" and performance by the subcontractor involved, his main criticisms were directed towards his own management team who he felt had not responded appropriately to the situation. He felt that the site team were not "chasing" the subcontractor enough to get either recompense for the delays or better performance. In particular, he stressed the importance of fully documenting the delay and its causes to 'cover' Roadbuilders in the event of a claim for delay from the client at the end of the job. He suggested that the subcontractor's file "should be full of letters of complaint to them - but it's not". In not doing so he felt that the firm was being left in a vulnerable position. He compared Roadbuilders "lack of paperwork" with the amount of correspondence entered into by the client's staff: "all the correspondence is being made by the RE and non by (Roadbuilders)". This view was corroborated by the Office Manager who suggested that the correspondence with the RE should be much more detailed. The point being made here is that, in subsequently arguing the case for an extension of time and against damages, Roadbuilders would be vulnerable to the case put forward against them by the Resident Engineer, and at the same time powerless to extract damages from their own subcontractor. The Works Manager added a further comment: that the site team would

be in a difficult position, vis-a-vis their own head office, in arguing that the problems on site were due to the subcontractor's performance if they were not seen to have taken sufficient steps to expedite the work. In relation to the detailed day-to-day management of the work, he added that the failure to commit to paper all the agreements reached with the Resident Engineer on site meant that the production and engineering staff were often not fully aware of what was going on on the project.

To a certain extent, this situation was attributed (by the Works Manager and Office Manager in particular) to a lack of clerical staff on site to handle all the necessary paperwork. They both described an "imbalance" in the firm's expenditure on staff overheads which, in their view, needed to be rectified in favour of the clerical and administrative side. The Works Manager's solution to the problem was in keeping with his views on office efficiency: namely, he felt that procedures needed to be more formalised, and documentation and correspondence much more detailed and extensive. However, a deeper underlying reason was given by both which was widely corroborated amongst members of the site team - namely, that there was a lack of centralised co-ordination and control of the work being undertaken on site. The Works Manager was again the most outspoken, although his opinions were representative of those expressed by the Office Manager and by the production and engineering staff. In the Works Manager's view, the Site Agent had by that stage become somewhat "divorced" from what was happening on site, and the Sub-Agent did not have sufficient experience to be able to fully cope with the project and the circumstances on it. This

was particularly perceived to be the case in relation to handling external relationships with the subcontractors on site and the Resident Engineer. The Works Manager suggested that there was a limit to the extent to which he himself could "cajole" the subcontractors into performing, and that "chasing" them was the job of senior management on site. He attributed the continuing problem on site to "the Sub-Agent not getting on the subcontractor's back". On the main contractor's internal management, he stated that ordinarily he would expect to be the one who was 'chased' rather than "doing the chasing" himself: "I'm used to a strong Agent and Engineer telling me to get on with it - not me telling the engineers what to do". In the opinion of the Works Manager it was the Sub-Agent and Engineer who responded to his initiative rather than vice-versa.

This last comment gives a hint perhaps of the impact that such a situation had upon the quality of working relationships amongst members of the site team. With the programme having 'gone critical', it was widely agreed that the main contractor's performance on site was heavily dependent upon the level of co-ordination achieved between the production and engineering staff. However, the Office Manager, for instance, characterised their working relationships as essentially lacking in co-ordination and communication. Stressing that, in his experience, such a situation was "untypical", he said that the foremen and engineer did not plan ahead any more; that weekly co-ordination meetings had now become "more post mortems than serious attempts to plan ahead". In particular, he described the engineers as being in a "biased" position: due to their relative inexperience, they could

"never win against the production staff". It was generally agreed (amongst both contractor's and client's staff) that the contractor's engineers were being expected to cope with too heavy a workload on the project. The ARE, for instance, commenting upon the contractor's internal organisation, suggested that the contractor should be employing more senior engineering staff and have properly-trained junior engineers on site to cope with the workload. It was also reported that a 'gap' had developed between the Sub-Agent and engineering staff. This latter opinion, expressed particularly by the Works Manager and Office Manager, was echoed in the comments given by the Site Engineer, who described what he felt was a lack of support given to the engineering staff, and increasingly infrequent direct contact with the Sub-Agent. He and his staff felt that the Works Manager was continually "hounding" them and "interfering" in their work. The ARE supplied some external corroboration for this by expressing the view that the Site Engineer was being "pushed around" by the production staff. The net effect, according to the Site Engineer, was that a situation had developed in which everyone was "talking behind each other's backs". It was noted that the Site Engineer, criticising the level of central support given himself and his staff, was at that stage considering leaving the company.

From these comments, what appears to have happened is that, in the absence of a co-ordinating role between the engineers and production staff being performed by the Sub-Agent, it became the more powerful of the groups - specifically in the person of the Works Manager - who stepped in to fill the gap and attempt to

restore control of the situation. However, in doing so, it was generally perceived to have exacerbated rather than eased the problems of co-ordination between the two groups: the engineering staff resented what they viewed as the pressure brought to bear upon them by the Works Manager, particularly given an already excessive workload, and felt that their interests were no longer sufficiently represented.

It is interesting to note that this situation as it was at the time of the second period of fieldwork, represented a manifestation of latent problems within the team that had been identified during the first period of fieldwork upon that site. During the course of the first visit, both the Engineer and General Foreman (and their staff) had expressed the view that there was to some extent a lack of trust between the production and engineering staff, and a lack of appreciation of the work done by each group. Specifically the General Foreman had complained that the engineers tended to leave him "problems to sort out", while the Engineer felt that the General Foreman did not appreciate the engineers' workload. At that stage, the role of the Sub-Agent in co-ordinating the two and resolving any difficulties that emerged had been emphasised by all those involved. However, by the second visit, the approach had altered. The Sub-Agent reported that his own response to this situation was to tend to let the production and engineering staff "sort things out amongst themselves", in order not to "disrupt co-ordination completely". In other words, his interpretation was that attempts to exert firmer control would exacerbate rather than ease the existing situation. In contrast, the Office Manager's opinion of what was needed was to have a major agent

responsible for the whole job, and an intermediary to manage and co-ordinate the work of the production and engineering staff. With both a Site Agent and Sub-Agent on site it would appear that there was sufficient managerial capacity on site to do this. However, as the earlier comments make clear, this was not happening. The consequence appeared to be an imbalance in the level of influence exerted in the running of the job which favoured the production staff.

At the same time, it should also be noted that relationships between the production staff themselves were not considered to be particularly close. The engineers, for instance, expressed the opinion that the General Foreman had by that stage "opted out", a view shared by the Trainee Foreman and Office Manager. The latter suggested that, with two experienced foremen on site, both of whom believed they were "right", a situation had arisen where there was little co-ordination between the two. Both the Office Manager and Storesman - involved in administering and accounting for stock held on site - cited numerous examples of the dual ordering of materials and tools by the Works Manager and General Foreman to illustrate the point. From the Sub-Agent's description of the division of responsibilities between the two following the secondment of the Works Manager, it appeared that no clear demarcation of their respective roles on the project had been drawn: the Sub-Agent made explicit the lack of any status differential between the two, and the expectation that they would work together "as a team" in managing the entire site. In the previous section (b.9) it was reported that the tendency was for the General Foreman to supervise the directly-produced work,

and for the Works Manager to supervise both direct and subcontracted work. It should also be reiterated that prior to the Works Manager's secondment, the General Foreman supervised the entire site, including subcontractors' work. What this suggests is that, in the absence of a mechanism to provide sufficient clarity as to who was now responsible for what aspect of the work, a more hierarchical patterning of the relationship between Works Manager and General Foreman actually emerged following the former's secondment to the job. The comments reported above lend weight to an interpretation that the Works Manager's efforts to exercise control were the more successful, and that the consequence was a breakdown in co-ordination between the two and the General Foreman's 'withdrawal'. This situation provides further evidence of the internal problems faced by the main contractor at that stage.

What appears clear from the foregoing discussion is that a 'vacuum' had developed within the site team where it was felt there should have been more centralised co-ordination and direction of the work. In the previous section (6.9) a distinction was drawn between the 'operational' and 'contractual' roles performed by the Sub-Agent and Site Agent respectively. By the time of the second visit however, it had become clear that the Sub-Agent was more directly involved in 'contractual' aspects of the job in place of the Site Agent, particularly with respect to handling relationships with external parties. For instance, it was reported that the Site Agent no longer attended weekly contract meetings with the Resident Engineer and that it was the Sub-Agent who had to "cope with the client". In being drawn more into the 'contractual' management of the work, the Sub-Agent was drawn away from the

more 'operational' management role he had previously been performing, with the consequences described above. Clues to why this had occurred were found in accounts given of the Site Agent's relationships on site - both with members of his own team, and, in particular, with the client's representatives on site.

In regard to the former, as noted earlier the Site Agent had described his role as dealing specifically with project costs, including negotiating alterations to the work. At the second visit to the site, this emphasis was strongly reiterated. Yet, during the first visit, symptoms of a split within the team that was perceived to have emerged by the second visit were visible and which related to this aspect of the division of roles upon the project. This was manifested most clearly in a number of exchanges that were observed involving the Site Agent, Sub-Agent and General Foreman, of which two might serve as illustrations: one involving the decision whether or not to purchase a particular piece of equipment (a pump); the other involving negotiations with the earthmoving subcontractor to undertake additional digging and backfill work that was needed. On both occasions the General Foreman argued for additional expenditure, whereas the Site Agent argued strongly against expenditure. The nature and validity of the respective arguments given are not at issue here. What is relevant here is the significant difference in attitude towards the project that they represented - this at a very early stage in its development. From the General Foreman's viewpoint, the Site Agent was "behind the times" in his views on appropriate methods of building, and too concerned with cost minimisation. This view was shared by the Sub-Agent and Site Engineer (and also, subsequently,

the Works Manager). From the Site Agent's viewpoint, his staff did not appreciate the importance of minimising the costs of the work to the contractor, and also were not giving him adequate "feedback" on what was happening on site. A stylistic dimension was also identified: the Sub-Agent in particular made explicit his own view of the Site Agent's 'stubborn attitude': "he only likes things run one way - his way ... he doesn't like it when you ram things home". To the General Foreman, the Site Agent's approach was formed by his attitude to his staff: that the Site Agent had expected to work with a more senior site staff, and that they were "being treated like kids". Consequently, by the end of the first visit, reference was already being made to a gap that had developed between the Site Agent and his staff. In part this related to characteristics of the style of management adopted, and in part it reflected a difference in perspective and approach towards the project - particularly with regard to costs.

It is interesting to set this picture in the context of the main contractor's approach to the management of the project from the head office angle. The Site Engineer's comments that in previous firms he had experienced far greater head office support and back-up for the site team, was an exception to the general view held amongst the site staff that the head office's involvement on the RAW project was expected to be limited and indirect, and that the site had sufficient staff to enable it to operate largely as a self-contained autonomous unit. Within the constraints set by the administrative procedures described in the previous section, the expectation was that the bulk of the decisions needed would be taken on site. This was to such an extent even, that both the

Works Manager and Office Manager stated that head office could not possibly know all that was happening on site, since the job had been purposely delegated, and was in practice run in that way. In that respect, they felt that head office were "not to blame" for the problems, or for any lack of support to the field. However, the comments concerning head office's lack of knowledge of the full circumstances on site, do perhaps lend weight to the Site Engineer's remarks, which implicitly suggest that the site was left 'to go its own way', although towards the end of the second period of fieldwork it was observed that visits by the supervising Contracts Manager, head office Planner and Engineer did become more frequent.

Perhaps more significant however, were comments made concerning the firm's modus operandi. In describing Roadbuilders there was a noticeable tendency amongst the main contractor's staff (particularly the more longer-serving ones) to suggest that, while the firm was 'a good one to work for', it was somewhat outdated in its methods (of building) and (management) procedures. The General Foreman, in particular emphasised the former, while the Office Manager focused upon the latter. The SRE afforded further commentary in describing Roadbuilders as "a little old-fashioned". The Office Manager, for instance described the firm as being "reluctant to face chance", and the head office as somewhat "removed" from conditions on site. To illustrate the point, he cited instances in which he had discontinued forwarding information on what he felt were "obsolete" and "useless" forms used as part of the company's personnel management procedures. He added that, having done so, he received no further requests for these forms.

A further point concerns the approach to project costs. The Office Manager, for instance, described the firm as "skinflints". More specifically, that they appeared unwilling to countenance extra expenditure to ensure completion of time and quality objectives. The situation with the underground drainage subcontractor was cited as one manifestation of the consequences. The ARE, for instance, suggested that the problem may have been avoided had the contractor not accepted the lowest bid for the work. His opinion on the need for more engineering staff mentioned earlier he set against the contractor's "attitude" of keeping overhead costs down. Looking back further at the origins of the contract and the position of Roadbuilders as a small firm tendering for work with a large and important public sector client, it is perhaps self-evident why the contractor may have put in too low a bid - particularly given the current economic climate. There was also a recognition (emphasised by the Sub-Agent) that the job had been underpriced in the first instance. It is also fairly clear why project costs may have been regarded as so critical, given the current cash-flow problems within the firm. However, the comments noted above, in relation to both the contractor's approach to costs and their modus operandi, also suggest a 'cultural' component in the contractor's approach to the management of projects: the firm was considered to be both somewhat out-dated in its methods and cost conscious in its management. These were not facets which arose solely in response to circumstances on this particular project, but which appeared to be more deeply embedded in the operating culture of the organisation.

The point to be made here is that such characteristics

compare closely with what was perceived to be the manner in which the Site Agent - as the company's senior representative on site - approached the project. In other words, the role that he performed as perceived by his staff, was the embodiment of the values and norms thought salient to the firm. It was not possible to establish to what extent this reflected an 'internalisation' of the firm's values on the part of the Site Agent, or was more directly based upon his remit for the project, given both the financial problems of the firm at that time, and also the fact that the job was underpriced. Whatever the mechanism, however, it suggests that the Site Agent represented the firm's interest in a very real sense - not only in his official capacity as "Agent" for the firm, but in the premises that underlined his orientation to the project, given the situation facing the company at that time and its traditional approach to contracting. Whether such an orientation to the RAW project was appropriate or counterproductive is, and certainly was, a matter of contention. What is less contentious is the impact upon working relationships among key members of the site team which stemmed from these basic differences in perception towards the approach that should be adopted towards managing that contract. Furthermore, the subdivision within the site team between the more senior staff involved in 'contractual' matters (the Site Agent and QS) and the rest of the team involved in the 'operational' side - given that it coincided with a clear hierarchical patterning of relationships on site - formed a structural backdrop against which relationships developed within the team on site.

Reference was also made to the nature of working relationships

between the main contractor and resident engineer's staff.

During the first visit to the site, as early as week 13 of the contract programme, a level of tension was reported in the relationship between the two groups - specifically at the most senior level - ie between the Site Agent and SRE. It was reported by the Sub-Agent that exchanges in weekly contract meetings were often "heated", and the General Foreman also expressed concern at the possibility of conflict between the two causing problems on site. The reasons suggested for this situation had as much to do with the 'style' or approach of the two to managing the work on site, as with positions held on particular substantive aspects of the work. According to the Sub-Agent, both the Site Agent and SRE wanted to "call the tune" and having things "their own way". The "stubborn attitude" of the Site Agent was compared with the perception of a desire by the SRE to control fully what was happening on site: the contractor's Site Engineer, for instance, described the SRE as a "frustrated contractor". To the Site Agent, efforts to exert this control by the SRE were interpreted as "interference" in the contractor's right to manage the job. To the SRE, allowing the contractor too much discretion amounted to giving the contractor leeway to "wheel and deal" which was inconsistent with what was contractually required. In effect, the consequence was a personal contest between the Site Agent and SRE over who controlled work on the project. As might be expected, it was issues relating to the cost of work that formed the 'agenda' for these exchanges. Staff from both teams, including the Site Agent and SRE themselves, reported that the arguments commonly centred around financial or contractual aspects of the relationship between the two. The SRE for instance,

noted the contractor's attempts to substitute less costly items than those described in the contract specification, while the Site Agent noted the resident engineer's refusal to accept more 'cost-effective' methods and cheaper materials than those specified. Specifically it was in obtaining the resident engineer's approval for the contractor's methods and materials (or those agreed with subcontractors) that the arguments arose. From the SRE's viewpoint, his job was to ensure that the main contractor stuck to the detailed terms and conditions of the contract: there was little, if any, scope for negotiation between the two on the detailed specification of the work. Attempts by the contractor to do so he interpreted as "wheeling and dealing". From the Site Agent's viewpoint, informed variously by the factors described earlier (the job being underpriced; the financial state of the company; the firm's approach to financial management), there was scope for negotiation in introducing substitute items or employing cheaper methods.

While cost factors were an important substantive element in the areas of disagreement, it is interesting to note the procedural mechanisms that were employed. During the course of the first visit a significant event occurred in this respect. At issue was the approval of a design submitted by a subcontractor who was to be appointed which contained "minor" modifications. This was according to the ARE, Sub-Agent and Site Engineer who had discussed the design informally. From this discussion, the contractor's staff had interpreted acceptance being given for the design by the resident engineer (subject to formal confirmation in the form of an instruction). However, on being informed of this by the

contractor's staff, the SRE rejected this interpretation and withheld approval; the ARE was 'dressed down' by the SRE for overstepping his authority in approving design changes; the ARE in turn criticised the Sub-Agent and Site Agent for assuming that approval had been given and then formally informing the SRE - hence undermining the ARE's position; the SRE meanwhile threatened that in future more formal mechanisms only would be used; the Site Agent countered by suggesting that in that case he would make sure that such dealings were escalated to head office level on both sides. The Site Agent's interpretation was that the SRE was "sticking rigidly to the contract" and, in "interfering" in this instance, had "thrown a handful of spanners into the works". The SRE's interpretation was that the contractor was "taking liberties" - both with respect to the specification for the work, and with the appropriate procedures for dealing with such issues. The interpretation of the event offered by both the ARE and Sub-Agent was that the issue had been blown up out of all proportion to its significance. Though a relatively minor issue, it was located in a contractual 'grey' area, upon which a point of principle had then been fought between the SRE and Site Agent.

It is interesting that this event happened so early on during the course of the project. What it suggests is a process of establishing what (both in content and procedure) would and would not be acceptable at a very early stage in order to lay the basis for subsequent interaction between the parties. In this respect the contractual authority of the resident engineer - approving changes or proposals made by the contractor was asserted,

together with the SRE's own personal authority as the client's senior agent on site. Perhaps what is of equal interest is the implication for the level of discretion afforded by the SRE to his own staff in discussing operational details with the contractor's staff. In other words, a clear signal was transmitted, not only to the contractor, but also to the SRE's own staff - that any changes or proposals that were discussed required his own formal approval before they were agreed. As noted in the earlier section (b.9) the level of involvement of the SRE in supervising the project was enough to elicit the comment from the ARE that such a situation was unusual. On the client's site team's internal structure, he also described it as one that was characterised by being highly formal and bureaucratic, as well as centralised. What these comments suggest is a high level of direct control exerted by the SRE in the running of the job and the close monitoring of decisions taken by his staff. As an additional and more general point that will be returned to in the later analysis, it is interesting to note the limits that were set to the pattern of informal working relationships that tended to characterise interaction between Sub-Agent and ARE as the individuals most directly involved in the operational management of the work. In other words, once an issue had 'contractual' implications, recourse was to formal procedures and mechanisms.

It is interesting to review the situation as it had developed by the time of the second visit to the site. At that stage, as noted earlier, it was felt that the Site Agent had "advocated" (the Works Manager) from conducting negotiations with the resident engineer's staff, and that the Sub-Agent had been left

to perform this role - although the Sub-Agent was seen to be too inexperienced "to be able to cope with the SRE" (Works Manager). By that stage, no further reference was being made to 'problems' in the relationship between resident engineer and contractor's staff with respect to the type of encounter described above. The Works Manager, for instance, described the resident engineer's team as "good to work with". To the rest of the contractor's site team, together with the client's staff who were interviewed, the nature of the relationship was no longer at issue. The noticeable change from the situation at the time of the first visit suggests that the SRE had managed to exert control over the project. This in turn perhaps suggests a factor which helps to account for the perceived 'distancing' of the Site Agent from the management of the project; given the comments made earlier concerning the personal contest between the two and the divergent perspectives that they represented.

Finally, in interpreting events on the RAW project it is important to bear in mind the position of the two senior representatives within their respective organisations. Firstly, the level of autonomy of both parties on site vis-a-vis their respective head offices suggests a high degree of discretion for the senior representatives on site in defining their own and their staffs' orientation towards the project as a whole. Further, their senior status, and in both cases their perception that their own staff were relatively inexperienced, formed the basis for expectations that the contract would be run in the manner in which they decided. That such expectations were disputed or challenged in one case, and imposed quite explicitly in the other,

suggests a point of departure in understanding the internal mechanisms of the two teams, and a clue to understanding the development of the relationship between the two. Put more simply, in being contractually in the more powerful position, and being in direct, central control of his own organisation, the SRE was at a distinct advantage in dealings with the main contractor, whose internal workings were characterised by clear divisions between the key staff involved. It is argued here that the dynamics that have been described above suggest that the two processes - internal and external - were related on the RAW project.

Secondly, in their dealings with one another, the SRE and Site Agent quite clearly reflected the goals of their respective organisations in relation to that project: in the case of the SRE, his approach was informed by the concern to stick to the specification that had been established for the work and the time and cost constraints within the contract. Particularly with respect to the design of the work, the SRE's approach was to regard it as, in the main, fixed and definitive. In the case of the Site Agent, his approach was informed by the concern to profit from the job, or at least to avoid or minimise losses in a situation in which the job had been initially underpriced. This meant, in relation to the methods and materials to be used, that there was viewed as being scope for alteration and negotiation. Clearly, these aims were somewhat opposed, and it became the more powerful of the representatives who held sway on the project.

7.1 The Project, Client and Context

This project involved the construction of a series of 36 advance factory units on behalf of a new town Development Corporation, for subsequent sale to private sector clients. Each unit consisted of a single-storey building containing basic amenities (water, gas, electricity). They were to be constructed to one of three size categories (12 x 24 m, 24 x 36 m, 36 x 48 m) of which there were 12 of each planned. They were to be built, as connected units, on a 'green field' site that was located on the outskirts of the town, on land owned by the corporation.

The project represented part of a continuing long term factory and warehouse-building programme being undertaken by the corporation as client, and which was being financed jointly by the corporation and private sector financial institutions (who provided, on average, 66% of the capital). The total expenditure to date on the programme had amounted to around £8.5 million, and a number of similar projects on other nearby sites had been completed, and the individual units sold to private companies. The units that were part of the AFU project were to be sold and occupied as they were completed. Consequently there was to be some degree of overlap between building work and user occupation: the project would be phased to allow the handover of groups of factory units before full completion of the works.

The Development Corporation was a sizeable public sector client

whose annual level of capital expenditure on housing, industrial and commercial buildings amounted to approximately £27 million. The bulk of this (£15 million) was expenditure on new housing. Investment in industrial facilities, of which the AFU was an example, amounted to just over £1 million annually (or less than 4% of this total). The AFU project, which was budgeted at £3.75 million spread over a two year construction period, was the only advance factory project currently in the process of construction. It was a fairly large project in itself, but constituted only a small part of the Corporation's total annual building activity. The size of the project was also relatively small compared to other projects (eg 'one-off' office buildings and shopping centres) undertaken by the client. Moreover, it constituted only one in a series of such projects within the longer-term development programme. Consequently, the type of project was one in which the Corporation had a good deal of previous experience.

7.2 The Client's Representatives

The work associated with the design and supervision of the AFU project was undertaken entirely in-house - within the Development Corporation's own Architects' Division. The division overall was headed by a Chief Architect who reported directly to the Board of the Development Corporation. In total it employed approximately 50 professional, technical and administrative staff, and consisted of a number of separate departments, each specialised according to their technical function (namely, architecture, surveying, structural engineering, mechanical and electrical engineering,

administration). The division was directly involved in the design and supervision of most of the building work undertaken for the corporation as client. Consequently, work on the AFU project represented only a small proportion of the division's activities, albeit constituting part of a longer-term programme. Previous advance factory projects had also been designed and managed by the division's staff, and this type of work was considered to be the more 'routine' side of the division's work in comparison with the larger-scale 'one-off' commercial and institutional projects that were also designed in-house.

It was noted that, at the time of investigation, there was an increasing tendency on the part of the corporation to sub-let work to private consultants - particularly for mechanical/electrical services design and (to a lesser extent) surveying functions. However, this was not the case for the AFU project, where all services were provided in-house. (It was also noted that where consultants were engaged, it would not be for the full duration of the project. Mechanical/electrical consultants, for instance, would be contracted to provide design services only, while on-site supervision of the work would be undertaken internally).

7.3 The Main Contractor

The main contract for the construction of the AFU works was let to Tower Construction (UK) Ltd - a private company registered as a 'building and civil engineering contractor'. The company was a wholly-owned subsidiary of Tower Holdings Ltd, which operated a group of companies engaged in construction and related activities

(eg property; housing development) both in the UK and overseas. Tower Construction (UK) Ltd was the group's main operating subsidiary in the UK construction market (excluding speculative house building). It was a large firm, with some 20 regional branches throughout the UK. In the accounting year that fell between the start and finish dates of the AFU project, its turnover on construction work was over £400 million (which amounted to about 40% of group turnover). It was a profitable company, whose fixed assets stood at £64 million and net current assets at £475 million. Its head office was located in London, and it employed some 2000 people nationwide.

The AFU project was managed and controlled from a regional branch of the company. That branch undertook all the company's work within a region covering five counties, and the branch office was located approximately 60 miles from the AFU site. It employed about 50 branch office staff and a total site-based staff and workforce amounting to 200. The volume of building activity it controlled was fairly sizeable - it accounted for an annual turnover of about £20 million. Consequently, the AFU project was relatively small in scale in relation to the volume of work being undertaken by the firm within the region, and much more so in relation to the size of the company's operations as a whole. It did not constitute a major project for that branch, and consisted of a type of work that was well within the capacity and experience of the company. However, it did represent part of a continuing relationship with the Development Corporation as client: the branch had recently completed work on 38 advance factory units on a nearby industrial estate, and had also built housing developments

for the corporation in the past. Therefore, there was some familiarity - both with the specific type of work involved in advance factory development, as well as with the client and their representatives across a range of types of project.

7.4 The Design Process and Design Organisation

The design process for the AFU project had involved the establishment of an architectural specification and drawings for the work, which were based upon a brief prepared by the Architects' Division, and approved at senior levels within the corporation. The drawings and specification, together with preliminary costings prepared by the surveyors had then provided the basis for the establishment of detailed architectural and engineering services designs, and the preparation, by the surveyors, of documentation for tendering.

The procedures and structure adopted for the design process had followed the normal practices of the division in its management of the design process. Indeed, it was noted that these procedures were formalised in the form of a detailed plan outlining the steps to be taken in the preparation of broad and detailed designs, the points for key decisions (eg obtaining approval for outline proposals,) and the level and extent of staff involvement during design. Such a degree of detail reflected the continuing basis of the division's project work, and an emphasis upon achieving regularity and consistency in project management procedures.

It was architectural staff within the division which formed the 'core' of the project teams involved in the design and supervision of projects generally. The overall management of individual projects from their initial brief through to completion on site was designated the formal responsibility of an architectural Project Manager. The detailed design and day-to-day supervision of the work on site would be undertaken by a Job Architect who reported directly to the Project Manager, and who was involved full-time on the particular project. This was the case for the AFU project: the Project Manager had been directly involved in the establishment of the original, broad proposals, and was then involved in co-ordinating work amongst members of the design team, while the Job Architect specifically undertook the detailed architectural design work.

Engineering and surveying personnel from other departments within the division worked collaterally with the architects during design (and construction). According to the Project Manager for the AFU project, they acted in effect as "consultants". The engineers (structural and mechanical/electrical) provided detailed designs on the basis of the brief and within the context of the architectural proposals for the project. They then monitored the implementation of their designs on site. The surveyors undertook the initial costings, prepared bills of quantities, managed the main contract tendering procedure, and followed through in the financial monitoring and evaluation of the work on site.

Within each of the four main departments (architecture, structural engineering, M & E engineering, surveying) there was

no formal specialisation or grouping of staff according to the type of work that was being designed and built. Instead each department consisted of a number of 'groups' which were assigned individual projects. Individual staff (eg architects and technicians) were seconded to project teams largely on the basis of their availability within each department, those allocations being made by the appropriate representative of each department at the 'project manager' level. Staff at that level from the engineering and surveying departments were seconded by their departmental heads, and followed the project through its design and construction stages. Their level of involvement would depend to a large extent upon the size of the project and the extent of the work involved for their particular discipline. For the AFU project, the involvement of senior 'consulting' staff, as well as of the architectural project manager, was not full-time.

7.5 Characteristics of the Design

The design for the AFU project - like those for previous advance factory projects - had been based upon no prior knowledge of specific user requirements, since these would only become apparent once the units had been sold to private sector clients. The fact that the users of the facilities were initially unknown, meant that the units had been designed with a view to providing multi-purpose factory and office space with only basic services and amenities provided. Consequently, the complexity of the finished product in each case was minimised, and the design for each unit was, to some extent, a replication of a basic structural model

applied to each of the 36 units, with adjustments made for their variation in size. The Project Manager, for instance, reported that the design effectively covered only five separate design aspects. Furthermore, the low volume of services work in this project meant that the work was relatively 'routine' when compared with the work involved in other (laboratory building) case studies included in the sample.

In relation to the overall programme of advance factory development by the corporation, the broad schematic plans for the AFU project were also similar to those for previous projects. The Project Manager did note that new changes were still being incorporated into the basic design as the development as a whole progressed. However, the similarity of this to previous projects, in addition to the factors described above, did help to reduce any 'new design' input. According to both the Project Manager and Job Architect, the tendency on these types of project was for the number of variations ordered to be substantially fewer in comparison with other, less standardised work that the division undertook. This was particularly the case given the absence of specific users' briefs and changes that might follow. It was reported that variations in the existing design tended to occur at later stages in the construction period, and in relation to detailed particulars, rather than to basic changes in design.

For the AFU project, there was little 'overlap' between the design and construction stages of the project. Most of the design information needed by the contractor for tendering and starting work was available by those stages. Further design activity was

to be associated mainly with the provision of detailed working drawings by architectural and engineering staff. According to the Project Manager and Job Architect, the bulk of the design information needed was early on in construction. Since the units were essentially similar, and also since they were to be built sequentially to allow for phased handover and occupation by users, then the same broad, and similar detailed designs for individual units or groups of units were applicable to the construction of further sections of the work.

In relation to the major features of the design for the AFU project described above, it should be noted that these points were corroborated by members of the main contractor's site staff. The project was characterised as one that was low in its design complexity, for which most of the design information was available, and on which there were few variations and no basic amendments during the project's course. In terms of the types of materials and methods of building that were to be involved, there was broad agreement amongst client and contractor staff, that the process of construction involved the use of standard materials and relatively 'routine' methods of building. The project was not considered complex in this respect.

7.6 Tendering and the Main Contract

The tendering procedure for the award of the main contract had involved a single-stage, selective competitive tender on the basis of a priced bill of quantities. According to senior staff in the architect's division, 'approved' contractors were selected

for inclusion on the tender list. That is, contractors were selected on the basis of their capacity to perform the work, taking into account previous performance records held by the division. (The same procedure was used in the selection of nominated sub-contractors.) The view was expressed by senior staff that the corporation had found in the past only about 3 or 4 main contractors who it was felt were capable of doing "such large jobs". Tower Construction were cited as one of these. Given the criteria accounted for in the selection of firms to tender, the decision to appoint Tower Construction had been made on the basis of the lowest submitted price.

The main contract was let under standard (JCT) conditions of contract (the local authorities editions) and comprised these conditions together with the bill of quantities, specification and working drawings (both those already prepared and those to be issued during construction). The value of the contract was set at £3.75 million (with allowance for price fluctuations), and the specified period for construction was 104 weeks (November to November). Work was to be evaluated, and the issue of interim certificates and payment to the contractor to be made, on a monthly basis with a 3% retention withheld. Provisional sums had been set aside in the bill for contingencies, dayworks, additional work and various fees and charges - mainly associated with the installation of statutory services (ie water, gas, electricity, telephones). The damages for delay varied between £100 and £700 per unit per week, depending upon the unit's size. The period allowed for final measurement and evaluation, the issue of the final certificate and payment was six months after the finish of

work on site. The defects liability period was also six months (except for the M & E services and landscaping where it was extended to 12 months). Included in the contract was the option for the Development Corporation to negotiate a continuity contract for further advance factories with the successful bidder, subject to that firm's "satisfactory" performance and "agreement" on price.

Approximately 50% of the prime cost value of the work was to be undertaken by nominated sub-contractors, employed under standard (JCT 'green' form) conditions. Separate nominations were to be made for the cladding, roofing, glazing, steel erection, electricity, heating, mechanical work and suspended ceilings. In addition it was noted that certain items of the work (eg the doors, plumbing components) were 'specified'. That is, the specification allowed for only a particular type of component to be supplied. This in effect meant the nomination of suppliers in some instances, without them being formally employed under nominated supplier terms and conditions of contract. The installation of services (gas, water, electricity, telephones) was to be undertaken directly by the relevant statutory authorities. A condition of the main contract was for Tower Construction to provide attendances and to co-ordinate their programme of work with the authorities' own programmes of work.

It was noted that no detailed programme of work was submitted by the contractor as part of the tendering procedure. Instead, the contractor was formally required to submit a programme within four weeks of the award of the contract (which corresponded to the start date on site). This would include a bar chart, a labour

and plant resources estimate, a materials supply schedule, a summary method statement and site layout plan. The programme of works would be planned to allow for the sequential handover of groups of units at contractually specified interim completion dates, and would incorporate the programmes of work agreed with the statutory undertakers. In addition, it would account for the programme of work already established for the main steel-frame construction, for which the nominated sub-contractor had already been appointed by the division.

7.7 The Main Contractor's Site Team

A full-time resident site team was employed by Tower Construction for the management of work on the AFU project. The site team was headed by a Site Agent, who reported directly to a visiting Contracts Manager from the firm's head office, who was also currently involved in supervising four other sites in the region. The site team consisted of production, engineering, financial and administrative staff as illustrated below (Figure 7.1). All the staff involved had been transferred from other company sites in the locality (rather than being either seconded from the firm's head office or recruited locally). With the exception of the Site Engineer, who was transferred from the AFU project to another site once the earlier, structural work was completed, all the staff were employed on site for the project's full duration.

The Site Agent had been the only member of staff involved in any way in the pre-site planning process. He reported that he had worked with the company's Planning Engineer at head office over a

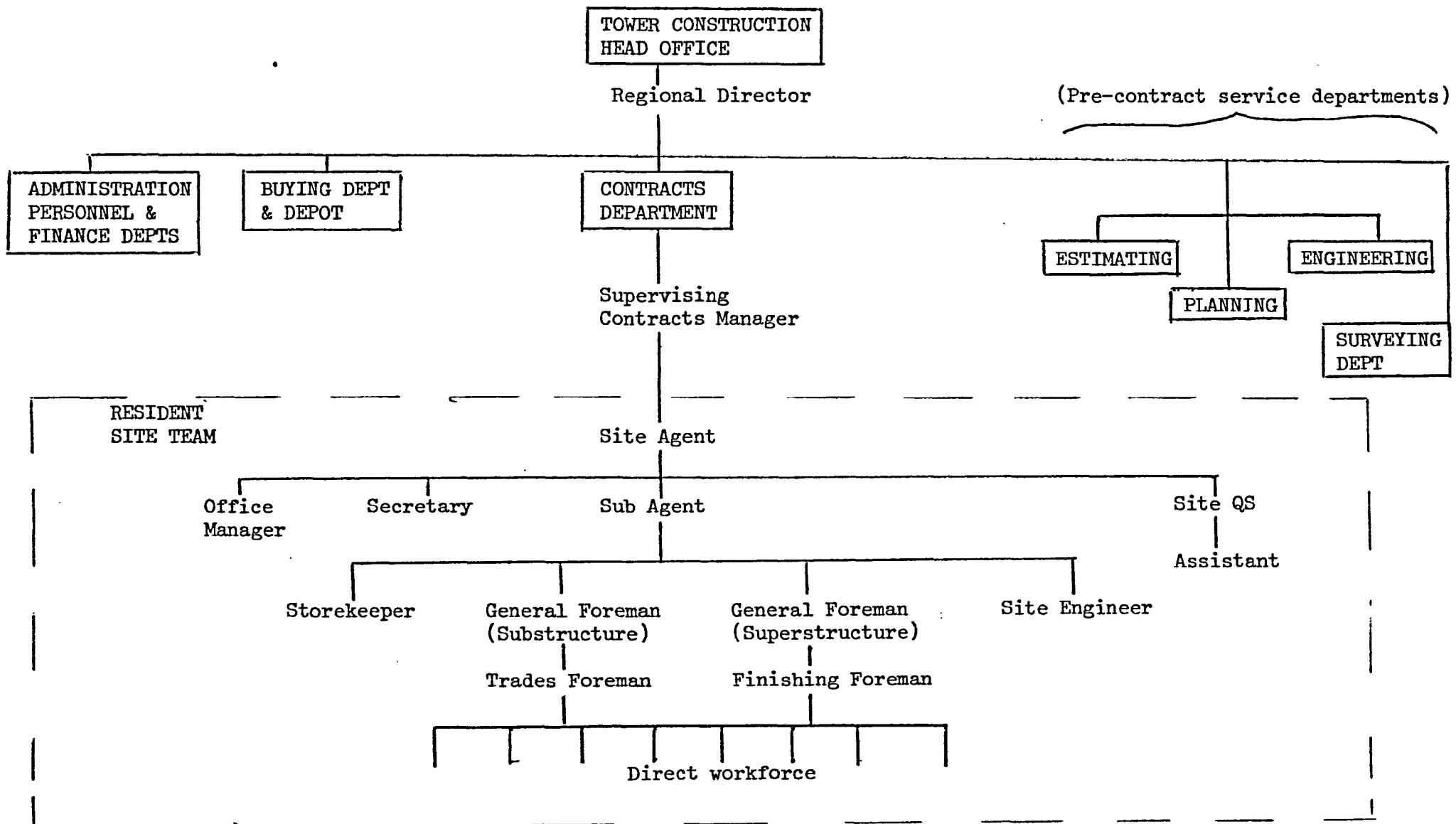

Figure 7.1 Tower Construction Ltd: Site management team and relationship to regional office

two- week period prior to the start of work on site. This had involved developing a detailed programme of work based around programmes of work that had been received from nominated sub-contractors. He had also been involved in arranging and negotiating domestic sub-contractors' programmes of work, ordering materials or plant that were needed early on in construction, and checking (with the Site Engineer) the drawings that had been received from the client for 'snags'.

The Site Agent described his own role on the project as being concerned with its overall management, including the handling of 'contractual' matters with the client and sub-contractors. It was the Sub-Agent who was primarily responsible for the detailed production and engineering aspects of the job in relation to the main structural building work. The latter's staff consisted of two General Foremen, each of whom was given responsibility for supervising separate aspects of the work across the 36 units - specifically the groundworks/substructure and the superstructure/finishing trades. Working for them were, respectively, a trades and finishing foreman, and a direct workforce of 40 concrete workers, joiners and general labourers. They also supervised the work on site of a sub-contract workforce that totalled around 50 (these figures for the numbers employed represent the estimated peak level of employment on site which corresponded to between a half and two thirds of the way through the programme of work). It should be noted that, because the work was 'phased' to allow for the sequential handover of groups of units, the involvement of the production supervisory staff was more or less concurrent

(rather than the two distinct aspects of the work - the groundworks and superstructure - being associated with a pattern of involvement of supervisory staff that corresponded to earlier and later stages in the overall programme of work).

The Site Agent described his previous experience as being centred mainly on managing housing contracts. He described the work on the AFU project as "less demanding" and "a change". It was also noted that he, together with the Sub-Agent and Site Engineer, had previously been involved in the construction of a nearby housing estate for the same client. Consequently, there was some familiarity amongst members of the contractor's site team, with the corporation's methods and procedures of building.

7.8 The Client's Supervision

The work on site was supervised, on behalf of the client, by the Project Manager and Job Architect who had been involved in its design. Both were based in the architect's department office, and visited the site at relatively frequent and regular intervals - the latter on average two or three times a week, the former on a weekly basis to attend meetings and in response to any operational problems on site. A similar role to that performed by the Project Manager was undertaken in the earlier stages of construction, by the Structural Engineer who had been involved in its design.

Additionally, a full-time, resident Clerk of Works was appointed to monitor the building work on a day-to-day basis. The Clerk of Works had been transferred from another of the corporation's sites

and was seconded to the project team from the architecture department's 'works' section. The appointment of the Clerk of Works was made by the Senior Architect within the department, and his involvement on the project was to come under the direct jurisdiction of the supervising architect. At the same time, the 'works section' employed a liaison officer, whose job it was to oversee the work of all the section's clerks of works seconded to architectural teams, and to act as a 'go-between' in the event of any problems arising.

In addition to staff on the architectural/building side, work on site was supervised by the surveyor and M & E engineer who had been involved during the design stages. The involvement of the former consisted mainly of the (monthly) measurement and evaluation of the work, done in conjunction with the contractor's site quantity surveyor. The latter's involvement related to the supervision of the mechanical and electrical services work installation on site. Towards the latter half of the project, when the services work was at its most intense, two part-time non-resident clerks of works were seconded to the team to supervise the installation of the mechanical and electrical services work respectively. Their appointment was made by the Senior Engineer within the M & E department, and they were seconded to the team from the equivalent 'works section' within that department. Their involvement on the project came under the direct jurisdiction of the M & E engineer and not the architectural team and the supervision of the M & E works on the project in effect 'paralleled' the structure of supervision on the architectural side (see Figure 7.2).

7.17

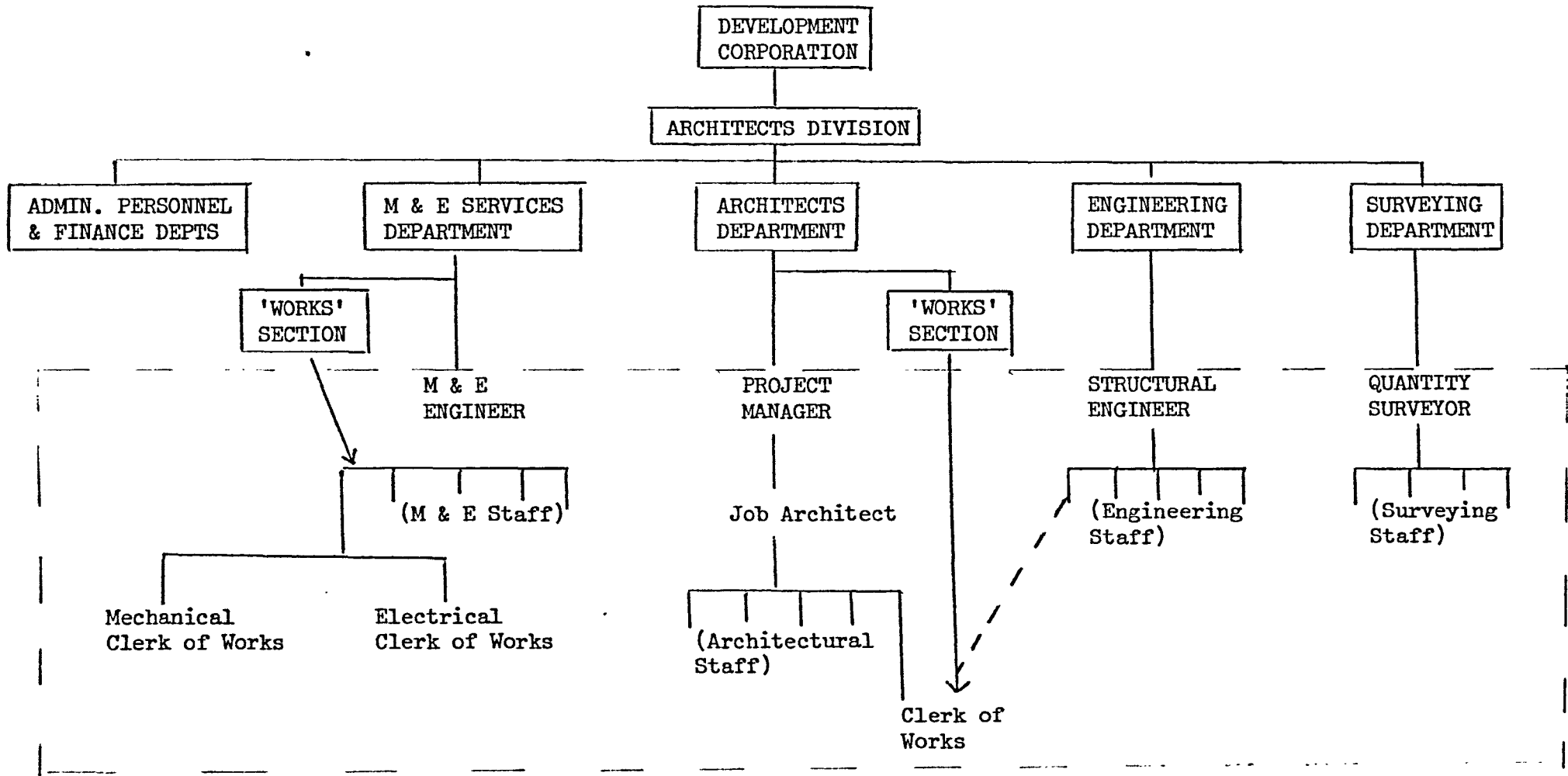

Figure 7.2 The client's 'project management team' on the AFU project and relationship to 'head office'

7.9 The Organisation and Management of Work on Site

Like the RAW project, the detailed management of work on site was based upon a monthly works programme, derived from the overall programme for completion. This formed the basis upon which detailed design information was requested from the client's representatives, and resources could be ordered and delivered to site. From the monthly programme, weekly schedules of work were drawn up, and issued to the sub-contractors on site. Directly-employed resources were requisitioned and delivered to site to suit the programmes of work - in the case of materials, via the Buying Department- in the case of plant, via the company's head office depot. The contractor's site team were then involved in setting out the work on site, and in supervising construction. Like the RAW project, the contractor's staff were also involved in placing new supply orders for materials (that were needed towards the later stages of construction) and placing sub-contracts (with 'domestic' sub-contractors also employed later on in construction) as the work progressed. In relation to materials and plant, it was reported that only minor items were purchased (or hired) directly from site and paid for at site level - all other resources were obtained via a requisition procedure against orders that were formally placed at head office. With sub-contracts, the tendering arrangements were conducted from site, and all subsequent correspondence between the main contractor and its (domestic) sub-contractors were handled on site. Again, contracts were formally placed and administered at head office level on the basis of information forwarded from the site.

As noted earlier, much of the work involved on the AFU project was undertaken by nominated sub-contractors. In addition, Tower Construction had sublet most of the remaining work to its own, domestic sub-contractors. Consequently, a good deal of the work associated with the management of work on site pertained to the main contractor's management of sub-contractors, rather than its own direct workforce. In terms of programming the work, it meant that an emphasis was placed upon agreeing or negotiating programmes of work with individual sub-contractor representatives, and in co-ordinating the work of interdependent trades on site. It was reported that fortnightly "co-ordination meetings" were held separately with nominated and domestic sub-contractors' representatives on site, involving the main contractor's Site Agent and Sub-Agent. According to the Site Agent, the meetings with nominated sub-contractors were mainly to discuss and agree programmes of work, while those with domestic sub-contractors extended to the co-ordination of trades' work on site, and "chasing up" sub-contractors who were falling short on progress. The Site Agent reported that the differential completion dates for groups of units coupled with the extensive use of sub-contractors (particularly in the finishing trades) put a greater emphasis generally upon the planning, sequencing and co-ordination of work on site. However, he also suggested that this helped to reduce the complexity of the work, since the work undertaken by any individual trade was not 'bunched' in one area. He also suggested that it made it easier to control: the repetition of the work from unit to unit made it easier to spot "exceptions" and for the contractor to compare the performance of sub-contractors.

In terms of design-related activities, the use of sub-contractors meant that the main contractor's role in these activities was limited to the checking of drawings, the agreeing of methods to be employed by sub-contractors, the setting out and general supervision of the work. Only for a relatively small proportion of the total volume of work in the AFU project was the main contractor involved in establishing their own designs (for temporary works) and methods of building. In most instances the main contractor effectively acted as a conduit for the transmission of detailed design information between the client's representatives and the sub-contractors who were actually performing the work. The nature of the work involved on the AFU project was such that rather less emphasis was placed upon these aspects of the work than was the case for the previous and following three case studies in the sample. Firstly, the use of steelframes for each unit limited the volume of temporary works to be built (ie formwork). Secondly, the basic similarities in the design for each unit, and the relatively 'routine' methods of building that were involved, meant that detailed specifications and methods used were both relatively standard and repeatable across sections of the work. Thirdly, the services work that was to be installed was relatively unsophisticated (compared to the following case studies) and low in intensity. This meant that the co-ordination of the M & E designs with sub-contractors' own shop drawings and detailed designs would be a less critical aspect of the job (than in other cases). The establishment of details and methods of building for the AFU project were therefore areas in which the main contractor performed largely an indirect role since the bulk of the work was undertaken by sub-contractors, and in which dealings at a substantive level would reflect the comparatively 'routine'

nature of the work involved. It was reported by the Site Agent and Sub-Agent (and corroborated by a senior representative from the firm installing the suspended ceilings) that the project was rather one in which the planning, sequencing and co-ordination of work on site - rather than its design - was the most critical feature of management on site.

This was reflected in the tendency for the main contractor's Site Agent to be more closely involved in the planning and co-ordination of work on site. He drew up the monthly programmes of work and, together with the Sub-Agent, established the more detailed weekly schedules, dealing directly with sub-contractors' representatives on site in establishing them. It was these two who were also most closely involved in conducting the tendering arrangements for new sub-contract and supply orders, and in putting in requisitions for bulk deliveries of materials and major items of plant that were needed on site. According to them both, it was the Sub-Agent who then handled the more detailed day-to-day management of direct and sub-contracted work on site, including checking drawings (with the Site Engineer), making sure directly-provided resources (plant and equipment) were available, and generally supervising the setting out of the work and its construction. The Site Agent tended to become more closely involved in the management of sub-contracted work: in "chasing up" sub-contractors and in response to any problems occurring in the planning, setting out and performance of sub-contracted work on site. It was reported by the staff involved in the direct supervision of the work that any problems in these respects would be internally "referred up" to the Sub-Agent; the Sub-Agent reported that he would tend to refer

up to the Site Agent any problems that had "contractual" implications, and needed agreement or negotiation with individual sub-contractor representatives on site. Similarly with any problems occurring in the drawings or specification that could not be sorted out on site by the Sub-Agent with the client's Clerk of Works.

The Sub-Agent directly supervised and co-ordinated the work done by the Site Engineer in checking drawings and setting out the works, and by the supervisory staff who, as noted earlier, specialised in supervising separate aspects of the work on site. It should be noted that most of the direct labour force on site were involved in working on the groundworks/substructure aspects of the job, and as such were supervised by that General Foreman. At the same time, however, the General Foreman supervising the structure and finishing trades work had access to members of the workforce to undertake 'general services' work in relation to the finishing trades and for 'attendances' on the sub-contractors who were performing the bulk of that work. The Sub-Agent was the individual who provided the information on daily output on site which formed the basis for weekly reports on progress drawn up by the Site Agent and distributed to the client's staff and the contractor's own head office.

The involvement of the contractor's head office staff in the detailed programming, resourcing and design of the work on site was generally limited to the receipt of information on these aspects supplied from site. They received copies of the monthly and weekly programmes of work and progress reports in relation to them; copies of correspondence between the contractor and sub-contractors and

client's staff - the latter including all the instructions formally given by the Architect; details of plant costs and materials deliveries; and details of the measurement of domestic sub-contractor's work. The head office, in the form of the company Buyer, formally approved and placed any sub-contracts and supply orders that were let during construction. The role of the head office then consisted of arranging deliveries of plant and materials to site on the basis of requisitions put in from the site, and the general administration of sub-contracts and supply orders, including their payment. Only minor items of materials and equipment were purchased directly from the site, and paid for from site. All other resources were obtained by requisitions against orders that were formally placed at head office level.

The site was visited, on a weekly basis, by the supervising Contracts Manager based in the locality. According to the site staff, visits made by other head office staff (ie the Engineer, Surveyor, Planner in particular) were rare on this project, and only occurred in response to specific operational problems, of which it was reported (and corroborated by the client's staff) few had occurred. There was general agreement, amongst members of the contract's site team, that their head office's direct involvement in this project was minimal, and that the site operated fairly autonomously. The Site Agent reported that he had been given the authority to take most of the actions and decisions that would be needed on the project, and that, in practice, this was the way in which the job had been run. Any decisions that he felt needed approval, he would refer to the visiting Contracts Manager. However, he noted that this had rarely happened on this project. He also noted that he and

his staff had direct access to "service" department staff at head office (eg the Planner, Engineer, Surveyor), and that they could be called upon to give 'information and advice' if need be. However, he also suggested that a project of this type and scale did not warrant a great deal of involvement at head office level, and that in practice these channels had rarely been used. The main contacts with head office instead tended to stem from the more formal procedures associated with the supply of plant and materials to the site, and the recording and transmitting of information on progress, alterations and negotiations with the client and sub-contractors, and the financial measurement and evaluation of the work on site. For the latter, it was noted that the site Quantity Surveyor had a "direct line" to the Surveyor at the regional office - although both Agent and Quantity Surveyor pointed out that any direct dealings in this respect would "go through" rather than "by-pass" the Agent on site.

The involvement of the client's staff in the contractor's programming and resourcing of the work consisted mainly of giving approval to the (monthly) programme of works established by the Site Agent, and in approving the appointment of sub-contractors and suppliers, the quality of permanent materials supplied and detailed methods of building proposed by both the main contractor and their domestic sub-contractors. It was the Project Manager who formally gave the approval for these, although it was noted that it was often the Clerk of Works or Job Architect who were most directly involved in discussing these items with the Site Agent or Sub-Agent and in checking the relevant details.

Apart from these more formal mechanisms, the direct supervision of the work on site - its setting out and construction - was undertaken by the resident Clerk of Works on a daily basis (and also, in the latter half of the project, the M & E Clerks of Works), and by the visiting architectural and engineering staff. According to the Clerk of Works, any problems that occurred in the building of the work that were minor tended to be sorted out on site between himself and the Sub-Agent or Site Agent, or with the individual sub-contractors' representatives on site. Any more serious problems, particularly those with financial or contractual implications, he "referred up" to the supervising Job Architect. Formally, the Clerk of Works was empowered to issue 'Site Works Orders' to the main contractor provided that they had no cost implications, and that they related to the structural work only. Those that were issued were subject to official confirmation in the form of an 'Architect's Instruction' issued by the Job Architect. Any with cost implications had formally to be referred back to the Job Architect for approval, before the contractor could be instructed to go ahead with the work. Any variations to the design that were introduced were to be supplied by the Architect (or Engineer) to the client's Quantity Surveyor who would then pass the details on to the contractor's Quantity Surveyor based on site for costing. The costed variations would then be sent back to the Project Manager, who was required to obtain higher level approval within the corporation for the expenditure of additional funds. If approval was given, the variation would be issued in the form of an Architect's Instruction to the contractor to perform the work (who would then issue it to the appropriate domestic sub-contractor).

According to the client's staff interviewed on the project, any queries or problems in relation to the M & E side of the works came back through the architectural channels. The supervising Engineer was required to "consult" with the Project Manager/Job Architect concerning any variation to the work or problems in its construction, and formal instructions relating to the M & E work came in the form of Architects Instructions, issued by the Project Manager, to the contractor (and thence to the (nominated) sub-contractor who was performing the work). On site, the M & E Clerks of Works did not have the formal authority to issue instructions and were required to refer back any problems to the supervising Engineer. It was reported that, while the supervision of the work on site involved a close working relationship between the building and engineering services' Clerks of Works, the formal channels for monitoring and controlling the work on site were quite separate. The 'cross-over' point in the organisation was at the Project Manager/M & E Engineer level, rather than lower down within the project hierarchy.

The main formal forum for monitoring progress on site was a regular three-weekly contract meeting held on site. It was attended by the Project Manager, Job Architect (who formally acted as chair), and the (building) Clerk of Works on behalf of the client, and by the Site Agent and Sub-Agent on behalf of the main contractor. At the meeting, the contractor presented a report on progress, set against the monthly plan of work, and the Clerk of Work's own summary of progress in relation to the contract programme (measured by the proportion of work actually completed by that stage against the proportion planned). Other items on the agenda

included the contractor's requests for (design) information and working drawings, sub-contract and supply orders needed and placed, plant and labour levels on site, and more general items stemming from the Architects' and M & E's inspections of the work. The details of the meeting were minuted and copies distributed to other members of the client's team, the corporation head office and the contractor's head office. In addition to those attending on a regular basis, it was also noted that a representative from the corporation's estates department attended the meetings at a later stage as groups of units became ready for handover by the contractor.

7.10 Performance on the AFU Project

By the time of the first visit to the AFU site, the project was just under halfway completed. The main structural work had been completed on most of the units, and the contractor was virtually ready to handover the first completed section of six units in which the services had been installed and the internal finishing work and external landscaping were being completed. Overall, the job was estimated to be "on programme" by the Site Agent - an assessment corroborated by the architectural staff. Financially, the work was estimated to be well on budget - again by both main parties. According to the contractor's QS, there had been few and only minor variations to the work. In terms of profit, the QS estimated the contract to be running marginally under an expected profit rate of 5%, the only significant loss so far at that stage stemming from supplies of hardcore materials employed directly by the main contractor. For the client, the Site Agent suggested that they may have lost some potential savings through insisting on 'preferred' fittings in the contract - although this was not viewed in any way as a significant element. He regarded the client's budgeting for the job overall as "pretty good". With respect to the relationship between the two focal organisations (the Architect's Division and the main contractor), the job was characterised as one upon which there had been few and relatively minor hiccups in the co-ordination of its design and construction, and on which working relationships were good. According to the Project Manager the site was "running very well". He noted that he had had personal experience of working with the main contractor on (3) previous projects (including working with

the current Site Agent) and that he had developed "a good working relationship" with the firm. The Job Architect and Clerk of Works similarly confirmed that the relationship between 'client' and contractor had been "good" on this project. From the contractor's viewpoint, the job was running "smoothly" (Site Agent). By that stage the quantity of outstanding design information needed by the contractor was relatively low, due to the factors described earlier. No reference was made to any significant delays in the receipt of design information nor to any major changes in the nature of the design itself. On the fixing side, few problems were reported by the client's staff in making sure the job was built as designed and specified, and no major problems were reported as having occurred in this respect. The aspect of the job which was generally accepted as being its most 'complex' feature - namely, the co-ordination of subcontractors' work on site to allow for the 'phased' construction of the units - was reported by the Site Agent as having created few problems in the running of the job. Success in this respect was attributed to the control exercised over the subcontractors' performance on site. According to the contractor's QS, for instance, the Site Agent was managing "to keep a tight rein" on subcontractors. With the nominated subcontractors on site, the Agent noted that whether problems occurred or not on site for the main contractor (with respect to design issues particularly) depended upon the relationship between the subcontractor and the client's representatives. In this case, he described the relationships as being "good".

A similar picture in relation to performance on the AFU project was given in subsequent visits to the site. As noted in the earlier

chapter, the span of the project over a two-year period meant that it was difficult to conduct further follow-up investigations towards the end of the construction period, and consequently the details reported here extend only to the situation on the project as it stood at week 70 of the contract programme. At that stage, the project was reported as still being on programme and within budget, and reference was still being made by both parties to the 'team' approach that characterised working relationships between the client's representatives and the main contractor on site. What was made clear was that the relatively 'routine' nature of the work, and the advanced state of the design in relation to it had meant few changes to the work (ie variations or additional work) and no major problems in its construction.

7.11 The AFU Project: A Case Analysis

Given this situation, it is interesting to set it in the context of what were perceived to be the dynamics of the relationships within and between parties during the course of construction. In particular, clear reference was made to undercurrents in the pattern of working relationships amongst members of the design team supervising work on behalf of the client. As will be seen, these factors were attributed as having no real direct impact upon the course of events during the construction of the AFU. However, in analysing the relationship between intra- and inter- organisational patterns of co-ordination and control, it is as relevant to address the issue of the perception of the situation as it informed each party's approach, since it raises important points that will be pursued more fully during the later comparison of cases and theoretical analysis

of the findings.

An early hint of internal differences within the design team was given by members of the main contractor's site team. In describing the pattern of interorganisational working relationships on site, the Site Agent for instance described what he felt was a degree of "tension" amongst members of the supervising team (the Project Manager, Job Architect, Clerk of Works). Specifically he felt that there appeared to be a "lot of conflict" between the Project Manager and Job Architect, and that this was manifested in contract meetings in exchanges between the two. He gave no specific reasons for this, other than to suggest that it was "internal" to the department, and possibly having something to do with the fact that it was the Job Architect's first project of this type, with which the Project Manager had considerably more experience. At a later site visit he was to suggest that it had to do with the degree of centralised control exerted by the Project Manager, and to the 'style' of management he adopted in relation to his staff. It should be stressed that these comments received no corroboration by the architectural staff, and that they represent only external perceptions of internal differences. However, to the extent that they informed the main contractor's approach to the design team, further comments made by the Site Agent are of some interest: namely, he suggested that internal differences should not be being aired 'in public' although he felt it was of "no advantage to us". In other words, these differences were directly visible to the main contractor - a point that will be returned to below.

A similar perception was offered of the relationship between the architectural staff and the Clerk of Works. Here the Site Agent felt that the architects lacked "confidence" in their Clerk of Works, and that this was manifested through exchanges in meetings during which the Site Agent himself became a virtual spectator. Interestingly, this aspect of relationships amongst the client's staff was confirmed by those from the team who were interviewed. The Project Manager, for instance, identified a lack of 'control' exercised by the Clerk of Works over the work on site. The Clerk of Works for his part suggested that the Job Architect was 'indecisive' and slow in taking decisions and supplying information. The factors that informed these opinions, and the reactions of those involved to the situation are important elements in an understanding of the relationship between the organisation involved and will be returned to below. At this point, however, it is useful to give some examples of the types of disagreements that arose and the stances which were adopted, as they were directly observed by the researcher during the course of meetings, to give some depth to the comments reported above.

At an early meeting, for instance, there occurred a disagreement between the Job Architect and Clerk of Works over the construction of sills on the units' roofs to allow for drainage and avoid leaks. The basis of the disagreement was whether the work was to be built as drawn (Job Architect) or modified to account for problems that were occurring in fixing (Clerk of Works). In this discussion, the Project Manager appeared to act as a 'mediator', eventually coming down in support of the solution offered by the Clerk of Works. The contractor's Site Agent remained silent

throughout the discussion. At an earlier point in the same meeting, the Site Agent had reported a two-week delay in the delivery of fittings (for the plumbing work), adding that he felt that these components were "uneconomical", but that alternatives he had suggested had not been accepted. Interestingly the Project Manager agreed that the fittings were uneconomic and the supplier "unreliable", and asked the Job Architect why those components had been specified, and who had specified them. As an additional general comment, he also asked the Job Architect why "changes" were occurring to the specification and who was initiating such changes. At a later meeting, in the absence of the Project Manager, the positions were juxtaposed: the Job Architect raised the issue that he had not been informed about details that had been discussed and agreed between the Project Manager and Site Agent, for which an instruction was requested by the Site Agent at the meeting. This seems to suggest that the Job Architect had been by-passed by the Project Manager. The Clerk of Works openly expressed his own view: that "there wouldn't be any delay if (the Project Manager) was here". Interestingly the Clerk of Works appeared to play a much more vocal part in the proceedings than had been the case in previous meetings at which the Project Manager had been present. According to the Site Agent, the Project Manager generally did not bring the Clerk of Works into the discussion "except as a sort of token gesture".

These 'snatches' of data by no means adequately describe relationships as they were or had developed within the design team. However, they do provide illustrations of the comments given above concerning the existence of divisions within the design team

and, in particular, the extent to which these divisions had a high 'public profile' vis-a-vis the main contractor. The main point to be emphasised here is in relation to the perceptions of the situation, and how it informed the main parties' approach towards one another. From the contractor's point of view, the Site Agent reported that he viewed the Clerk of Works as the direct channel of contact with the client's team, and through whom everything (information, instructions, exceptions) would be directed. He reported that he relied heavily upon a good working relationship with the Clerk of Works, and that while the situation allowed the contractor to "ride a little roughshod" over the Clerk of Works, he would tend not to because it might "damage" the relationship they had developed. He stated his preference not to "rock the boat" by putting the Clerk of Works in an awkward position with the design team.

Interestingly, his perception of the Project Manager - Clerk of Works relationship included the observation that possibly the Project Manager "feels that (the Clerk of Works) may be colluding too much with us". While this point was not specifically referred to by the Project Manager, it was however addressed by him in more general terms. In describing at some length the role of the clerk of works in supervising the work, he drew a firm distinction between clerks of works who "let the contractor know (that) he is in charge", and those who "let the contractor run rings about them". In other words it was the capacity to 'handle' the main contractor, in terms of asserting their authority, that formed a major criterion in the Project Manager's assessment of the capabilities of clerks of works. As a general commentary he

identified 'strategies' adopted by some clerks of works early on during construction aimed at ensuring the contractor "knows who's boss, and that he's not putting up with any nonsense" (specific examples were given of the clerk informally mentioning work was not up to standard, letting the contractor do it, and then rejecting the quality of the work). From the Project Manager's and Job Architect's view, a situation where a 'balance' was achieved between a 'hard line' and 'soft line' approach was the most preferable since the former meant the likelihood of antagonism between the parties, while the latter encouraged a degree of manipulation by the main contractor. A more general point relates to the inferences that these comments hold for the position and role of clerks of works in relation to the design and construction teams. On the one hand the clerk of works comes under the direct jurisdiction of (architectural) members of the design team and represents their interests in the construction of the work in relation to the design. On the other hand, his orientation towards the job takes a building, rather than design, slant. In describing his working relationship with the Job Architect for instance, the Clerk of Works suggested: "he thinks in very different terms from the way I do ... he looks at it differently". While by no means conclusive, these comments do suggest an element of divergence in orientation towards the work, which forms a counter-point to the structural position of the clerk of works in relation to staff from the design side. Set in this context, the earlier comments upon the role of a clerk of works suggest a degree of dependence upon personal control exercised in the performance of this role that may or may not be matched by the level of internal control exerted by members of the design team. For the clerks of works

it suggests that their position is to a certain extent ambiguous as well as demanding. At what point, for instance, is 'cooperation' or 'collaboration' regarded as 'collusion'? In terms of the basis of their authority in dealing with both design and construction teams, at what point does 'expertise' in building matters give way to the 'position' power within the internal hierarchy and in the contractual relationship between the parties. These issues will be returned to in more detail in the later analysis. The perceived characteristics of the situation on the AFU project are interesting in these respects, since they suggest both an awareness of these factors, together with some insight into the strategies employed by the respective parties to respond to the situation. Specifically, the clear reference by the contractor for the need to have a close working relationship with the Clerk of Works contrasts somewhat with the perception of the architectural staff of the need for the Clerk of Works to exert direct control.

A further point of interest on this project pertains also to the issues described above, but this time in relation to lateral working relationships among members of the design team - specifically between the architectural and engineering staff. Again, the Site Agent recognised the visibility of internal processes: "there was a lot of internal wrangling earlier on in the Corporation between the architects and (structural) engineers". This time, however, it was perceived as having implications for external relationships: "though it didn't affect us directly, we could use it to our advantage, in that we could gain the support of the architects in disputes with the engineers ... that's quite beneficial as you can imagine" (Site Agent). The suggestion

here is that internal inter-functional disputes offered the main contractor the opportunity to secure a degree of leverage - or to play one party off against the other to a certain extent. This situation that was described occurred before the first visit to the site, and interviews were not conducted with members of the engineering group involved on the project. Moreover, the architectural staff offered no corroboration on the occurrences of disputes, and no further details were given of the substantive issues involved by the Site Agent. Consequently it is impossible to infer anything directly about what happened, except insofar as it affected the contractor's own strategy. In this respect two points are of interest. Firstly, that inter-functional disputes within the design team were seen to be to the 'advantage' of the main contractor. Secondly, that this contrasts with the perceived lack of 'advantage' afforded to the main contractor of differences within the architectural supervisory team.

On relationships between the architectural/building and mechanical and electrical engineering services side, there was general agreement amongst those interviewed that the two ran almost in parallel. Unlike the situation on the PDL project (Chapter 10 below) and the MES and NSS projects (Chapters 8 and 9 below), the co-ordination of structural and services work was regarded as neither particularly complex nor particularly critical. At site level the Site Agent reported that: "we have very little to do with the M & E side ... we let them get on with it". Similarly, the Clerk of Works described his direct dealings with the M & E Clerk of Works as minimal,

any problems on site being referred up to the project manager level. All parties emphasised the more specialised nature of the work, and a corresponding tendency to let the specialists deal with it. In a series of general comments that will be returned to in more detail in the later analysis, the Project Manager did describe a degree of "reliance" upon the M & E engineer, due to the specialised nature of the work, and a corresponding loss of "control" over that aspect of the work. For instance: "its very difficult to get what you want, because subcontractors pick up new products and you have to rely on the judgement of the (M & E engineer) ... because we don't know enough ... its not always the case that the M & E work is fully in accordance with what we want". However, working relationships in respect of this aspect of the work on the AFU project were not regarded as problematic, a situation attributed to the nature of the work involved and its almost separate management within the project.

CHAPTER EIGHT

CASE STUDY: The Materials Testing Station (MTS)

8.1 The Project, Client and Context

This project involved the construction of a new building, which was to serve as a materials testing laboratory for a central government-funded research establishment. The research establishment was attached to a central government department which was formally to act as the client for the project and the project was financed from central government funds. The building was to be three storeys high and would measure about 50 x 30 metres in area, yielding a floor space of some 4000 m² to be used for laboratories and offices. The location for the building was to be on a formerly unoccupied site within the existing grounds of the research establishment. It would be built close to existing occupied buildings and the site itself was fairly constrained by the close proximity of these existing facilities.

The project was a 'one-off' undertaking, geared to the expansion of the research establishment's existing facilities for conducting research on materials and energy consumption. It would house staff and equipment involved in this aspect of the establishment's work, and was itself to be designed with a view to achieving low levels of energy consumption. There was to be no overlap between the construction of the building and its occupation: staff, furniture and special equipment would only move in or be installed about four months after the final completion and certification of the building work.

While the project represented a significant extension of the research establishment's existing facilities to house research staff and equipment, it represented only a small capital investment by the client department. Indeed, that department was the largest public sector client for building work, controlling a total annual level of capital expenditure on new building work, repairs and maintenance well in excess of £1000 million. It undertook the full range of building work associated with the development and maintenance of the central government's entire building stock. With an estimated budget for the MTS works of £750,000 spread over an 18 month construction period, the project was therefore small relative to the expenditure plans of the client, and represented only one in a large number of new construction projects of varying size being commissioned by the client.

8.2 The Client's Representatives

The work associated with the design and management of the MTS project was undertaken in-house, within the Building Services Organisation (BSO). The BSO was a property and building management agency that was attached to the central government department that acted as client for the MTS project. It was a vast organisation which was charged with meeting the needs of government departments and other public sector clients for land, accommodation, installations, supplies and transport services both in the UK and abroad. At the time of investigation, it employed some 40,000 staff at home and overseas, including some 4000 architects, 1200 engineers, and 750 surveyors. It managed a total level of annual capital expenditure on major new building works in the UK in the region of £200 million.

Additionally, it accounted for £70 million worth of small building works and site purchases. According to official estimates, the total current volume of work being undertaken included some 2000 projects in the design stages, and about 1500 under construction at home and overseas.

The BSO consisted of four main divisions: a centralised design services division (offering architectural, engineering and surveying services across the BSO's operations); a division involved in defence and diplomatic-related work; a division responsible for non-defence services; and a civil accommodation division, which was responsible for the BSO's non-defence building projects in the UK (see Figure 8.1). Each of these divisions was headed by a Deputy Chief Executive who reported directly to the Chief Executive of the BSO, who was a Second Permanent Secretary within the overall government department.

It was within the latter division - civil accommodation - that the work specifically associated with the MTS project was undertaken. More precisely within the Civil Design Department of the civil accommodation division (CDD). (The division housed one other department providing estate surveying services.) The CDD was headed by a Director who reported directly to the division's Deputy Chief Executive, and it consisted of a number of sections specialised according to the type of professional services provided (namely architecture, structural engineering, mechanical and electrical engineering, surveying). In total the CDD employed some 100 professional, technical and administrative staff. It handled all of the new building work for civil

8.1

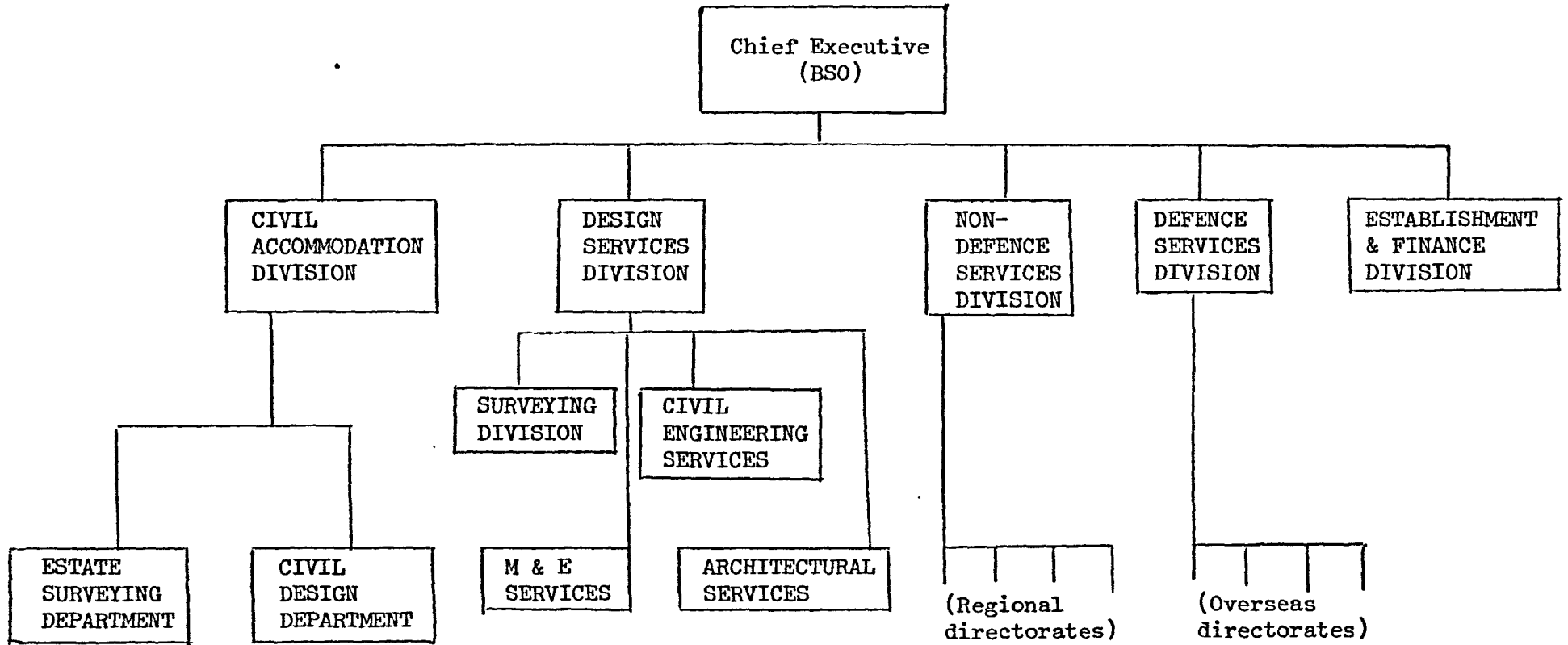

Figure 8.1 The Building Services Organisation and the Civil Accommodation Division

accommodation that was commissioned by the central government department, and also undertook renovation and maintenance work for central government and other public sector clients. The type of projects it was involved in designing and managing similarly reflected the full range of government-financed civil works: at the time of investigation the projects being undertaken ranged from large warehousing and depot development to small scale renovation work on listed buildings. Moreover, many of the projects that came under the jurisdiction of the CDD were one-off developments. The MTS project was, therefore, well within the capacity of the department - both in terms of its scale, and in the type of work involved.

For the financial monitoring and evaluation of the work on site following the main contract award, a private consultant (the PQS) was appointed. Contractual arrangements with the consultants were handled by senior surveyors within the CDD. The PQS's role was limited to the construction stage of the project: it was in-house surveyors who had undertaken the initial costings for the project and who had prepared documentation for tendering and managed the main contract tendering process. Consequently, for the MTS project, there was a separation of roles between staff involved in financial planning and monitoring functions.

It should be noted that while the MTS and other current projects were being designed and managed internally by the CDD, the view was expressed, by some senior members of the department, that future design work for any government projects other than the smallest was likely to be let out to private consultants. This

was attributed to cutbacks in central government expenditure. The view expressed was that the role of the department would then consist mainly of the design and management of small building works, and the briefing and co-ordination and supervision of external consultants' detailed designs for larger works.

8.3 The Main Contractor

The main contract for the construction of the MTS works was let to Claypipe Contractors Ltd - a private company, registered as a 'general building contractor'. The company was a wholly-owned subsidiary of Claypipe Holdings Ltd, which operated a group of four companies engaged in construction, and seven companies in related activities (eg timber, plant, land developments, (speculative) housing). The group as a whole employed some 4800 personnel nationwide, and had an annual turnover level of £150 million. It was a profitable company, and held fixed assets of £21.5 million and net current assets of £10 million. Each of the four construction companies, of which Claypipe Contractors was one, were regionally-based operating subsidiaries of the holding company. They each had an annual turnover in the region of £16 - 18 million, and together accounted for just under half of the group's turnover.

The head office of Claypipe Contractors Ltd was located some 30 miles from the MTS site. The firm undertook work within the surrounding region, and employed about 80 central office staff, and a site-based staff and workforce totalling around 200. The MTS project by itself was small relative to the total volume of

building work undertaken by the company, and in comparison to other projects with which it was involved at the time. However, it did represent work being done for an important client, and one with whom they had previous working experience. The company had in the recent past completed work for the same research establishment whose members were to be the users of the MTS facility, and this project had involved working directly with the CDD. It had also involved some familiarity with the type of work associated with the MTS as a 'one-off' laboratory building project.

8.4 The Design Process and Design Organisation

The design process for the MTS project had involved the preparation of an outline design and costings of the work on the basis of the brief supplied by the user (the research establishment). This had been undertaken by an architect appointed as 'Design Team Leader' together with other members of the design team who had by that stage been seconded from other sections to work on the project. Following the approval of the outline proposals by the user representatives and the client department, the design team was involved in the detailed design of the works and the preparation of contract documents. It should be noted that the procedures that were established to deal with projects from their very earliest, initial conception stages through to completion on site, handover and occupation, were described in full detail in a formal document which ran to some 80 pages in length. The document was intended as a 'procedural guide' to the management of projects and contracts, and described in full detail the expected nature and level of involvement of staff throughout the various stages of a project,

the points for key decisions, and the nature of involvement of staff in these decisions.

The Design Team Leader reported directly to a senior architect who acted as Project Manager for the MTS job, and who had appointed the Team Leader from his own team of architects within the department. This basic structure of management established for the MTS project followed the CDD's normal practice. Within the CDD, it was architectural staff who formed the core of the project teams involved in the design and supervision of building contracts. A Project Manager from the architectural section would be appointed by the architectural section head to oversee the entire project through from conception to completion. They would appoint, from their own team a Job Architect, who would "manage the building contract", and who would often be expected to have acted as Design Team Leader - as indeed was the case for the MTS project. Although a formal distinction was drawn between these two roles, it would only be in the case of large projects (unlike the MTS) that the roles were performed separately. According to the department's procedures, the Design Team Leader was expected to be a member of the predominant design discipline (in the MTS case, and normally within the department as a whole, an architect). The role of the Design Team Leader was formally specified as involving the 'co-ordination' of design activity throughout each stage of the design process.

The involvement of staff from other sections for the MTS project, similarly followed normal procedures. That is engineering and surveying staff were seconded by their section heads, and

"on request" by the Project Manager, to work in conjunction with the Design Team Leader/Job Architect. Engineers (structural and mechanical/electrical) provided outline designs to the brief supplied by the user, within the context of the broad architectural specification for the works. They were then involved in establishing detailed designs - in conjunction with specialist sub-contractors in the case of the M & E - and in monitoring their implementation on site. Surveyors were involved in initial costings, the preparation of contract documentation, the tendering procedure, and the financial monitoring and evaluation of work during construction. (As noted earlier, it was a PQS who performed this latter function on the MTS project.) The secondment of staff to individual projects was largely influenced by current availability within each of the sections in the CDD. There was no formal specification - either between groups in each section, or within those groups - according to the type of work, its geographical location or the client department.

With regard to the involvement of individual members of the MTS project team (during both design and construction stages) it should be noted that each of the principal design roles (ie Design Team Leader/Job Architect; Structural Engineer; M & E Engineer) was performed by a number of different personnel during the course of the project cycle. Specifically, by the time that work on site had finished, there had been three architects, five structural engineers and five M & E engineers involved in the project at various stages and for varying lengths of time. Consequently, while there was expected to be consistency in the role of design team members throughout the project, this was

not in practice equivalent to the continual involvement of specific role-holders. According to senior staff within the department, this tendency, which was not specific to the MTS project, reflected the department's staff placement practices, rather than any form of specialisation according to the stage of work or process, or the removal of particular staff from the project. It had implications for the organisation of the project, in terms of the relationship between design and construction. It meant that, despite the size of the project implying a combination of the roles of the Design Team Leader and Job Architect and for them to be performed by one individual, in practice they were not. The same was true for the engineering design specialists involved in the project. Consequently, there was a de facto distinction between design team members and job supervisory staff. Indeed, there was a further fragmentation of individual design team members' involvement in the project due to the sheer number of individuals involved in its design and management over time. The implications of this situation will be returned to below.

8.5 Characteristics of the Design

As noted earlier, the MTS project was a 'one-off' development to be built to the user's specification. Consequently, the design for the building was also one-off, although as mentioned earlier, it was not a type of work with which the CDD was unfamiliar. The function of the building as an experimental laboratory meant that allowances had to be made for the installation of extensive mechanical and electrical services, coupled with specialised fixtures and fittings (eg fume cupboards, lab benches etc).

Consequently, a major design feature of the building was the emphasis upon services work, and its integration with the overall structural design of the building. (Unlike the other two laboratory case studies in the sample, the design for the building did not specify the use of a suspended ceiling. The services instead were to be 'visible' within it.)

The structural design for the building specified the in situ construction of a reinforced concrete frame clad with precast panels and external tiles. The internal structure of the building (office walls etc) was to consist of block and brickwork walls with plaster and paint finishes. Externally, the work involved the connecting up of the building with existing drainage and gas, water and electricity supplies, the laying of access paths and general landscaping. Consequently, the methods of building and materials to be employed for the building itself were relatively standard. It was in the installation of the services within the building that work was to be less routine, in terms of the types of materials used and the detailed methods of building.

The design for the MTS project had been prepared over a five year period prior to the work actually starting on site. During that time, an extensive and fully detailed set of documents for the bill of quantities and specification had been drawn up. This meant that there was intended to be no basic design 'overlap' into the construction stage: a clear separation of the design and construction stages for the project was intended, according to design team members. This was not the case, however, with the mechanical and electrical services designs. The specification at

the main contract tendering stage incorporated only broad M & E designs which were then to become more detailed when designs were submitted by the appointed M & E sub-contractors and agreed with the design team. Consequently, this important part of the design for the MTS project was to occur during the course of construction. As a corollary to this, any variations or additional work that occurred would be expected to arise when integrating the detailed M & E designs with the main structural design, or as a result of the installation of the services work on site. According to the Job Architect, it was the policy of the CDD to "design the basics beforehand", and for the M & E detailed design work to occur during construction, when the main services sub-contractors had been nominated and appointed. He also noted that, while the basic structure of the building was specified in detail, this did not necessarily preclude design changes - even major alterations - once the main contract had been let, and construction was in progress.

8.6 Tendering and the Main Contract

The tendering procedure for the award of the main contract had involved a single-stage, selective competitive tender on the basis of a priced bill of quantities. According to senior staff within the CDD, contractors with the capacity and experience to perform the work were chosen for the shortlist for tender on a 'rotation' basis, to avoid the placing of too many contracts with too few firms. Ratings of previous performance on central government contracts were taken into account in their selection. Given these factors, the decision to appoint Claypipe had been

made on the basis of the lowest submitted price for the job.

The main contract was let under the GC/Works/1 conditions of contract, which is the standard form of contract adopted for central government-commissioned work. The contract between the BSO and Claypipe consisted of these conditions, together with the bill of quantities, specification and working drawings (both those already issued and those to be issued during construction). The contract was let for £750,000 (with allowance for price fluctuations), and the specified period for construction was 78 weeks (June to December). The work was to be evaluated, and the issue of interim certificates and payment to the contractor to be made, on a monthly basis with a 5% retention withheld. Provisional sums, totalling 4% of the main contract value, had been set aside for contingencies and extra work. An important feature of the BSO's contractual policy was its emphasis upon the settling of claims only after full completion of the work. That is, claims from the contractor for delays or variations were not negotiable while work was still in progress.

A large proportion of the prime cost value of the work was to be undertaken by nominated sub-contractors, employed under standard (JCT 'green' form) conditions of contract. Separate nominations were to be made for the windows, heating systems, plumbing, mechanical and electrical work. Sub-contractors were to be paid fortnightly with a 5% retention withheld. An important point to note is that, under the GC/Works/1 form of contract, a greater onus is put upon the main contractors in their management of nominated sub-contractors than is found under the

standard JCT form (eg Porter 1980). In particular, the 'grey area' of contractual responsibility for the performance of nominated sub-contractors is made more directly the main contractor's responsibility. This point will be returned to below.

A programme of works was submitted by the main contractor during tendering. It formed the basic plan for the construction of the works within the contractually specified time limit of 78 weeks. Essentially, it involved the 'building up' of the work from its foundations with each of the trades following on from one another. With much of the services and fittings work nominated, the external walls consisting of prefabricated units, the work undertaken directly by the main contractor was limited in the main to the groundworks and in situ concrete works and the internal structure (brick and blockwork). The main contractor employed 'domestic' sub-contractors for the bulk of the work in the main finishing trades (eg plaster, decoration).

8.7 The Main Contractor's Site Team

The number of staff involved in supervisory work on the MTS project on behalf of the main contractor was small, reflecting the relatively small scale of the project in financial terms. It consisted of a Site Agent, whose 'team' included a General Foreman, Trades Foreman and Site Engineer (see Figure 8.2). Each of these had been transferred from other company sites and were employed full-time on the project. With the exception of the Site

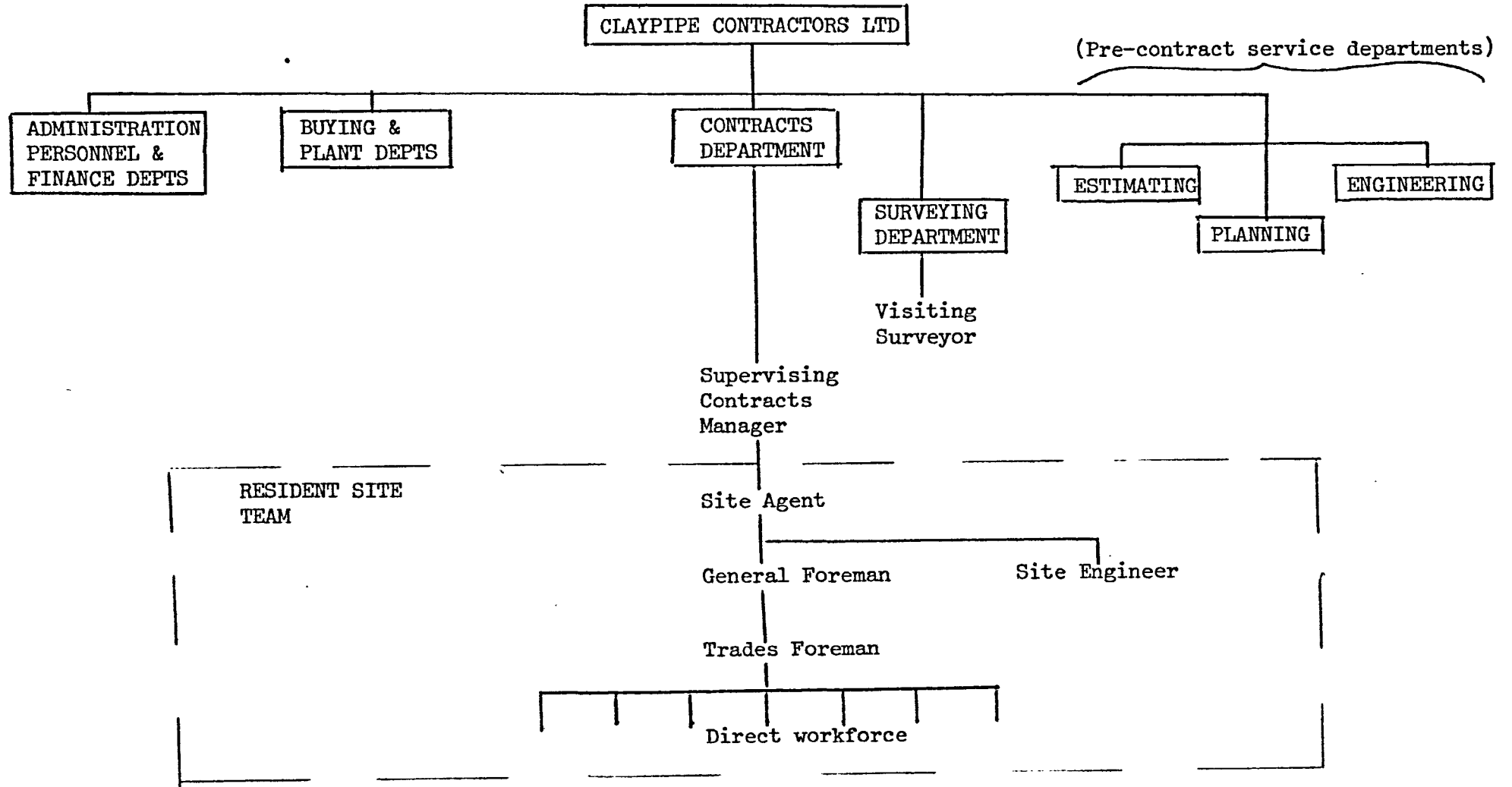

Figure 8.2 Claypipe Contractors Ltd: Site management team and relationship to head office

Engineer, who was transferred to another site after the structural work was complete, each was employed for the full duration of the construction stage. The site was visited by a supervising Contracts Manager (on a biweekly basis) and by a Surveyor from head office (less frequently, for evaluations, etc). The Contracts Manager who was interviewed in the latter half of the project, reported that he had "come in quite late" on the project, replacing a predecessor. He was currently involved in supervising (4) other sites. The Site Agent was the only member of the contractor's staff who had been involved in any way in the pre-site planning period. His involvement had been in a two-week 'familiarisation' period based at the firm's head office. He stated that he had no previous personal experience of working for the BSO, although he had had experience of doing a similar type of work to that involved on the MTS project. According to him, the structure of supervision on site was "the usual set-up": the size of the project did not warrant a bigger staff than they had on site. The site had direct access to services provided by head office (eg planning, engineering) and via the visiting Contracts Manager and Surveyor. Within this context the site team reported that they operated with a good deal of autonomy: in practice central support services were rarely called upon.

Given the limited number of staff involved in the project's management on site and the size of the project, there was somewhat less specialisation of roles amongst members of the contractor's site team than that described in earlier case studies. The Site Agent drew up the monthly and weekly programmes of work that formed the basis for constructing and supervising the work on site,

and placed bulk orders and requisitions for materials and plant - the former set against orders formally placed at head office level (by the Buying Department), the latter via the company's depot. The Site Engineer was involved in checking drawings issued by the client's staff, checking permanent materials deliveries and setting out the work on site; the General Foreman was more directly involved in making sure that plant and equipment was available, and in directly supervising the work of the direct labour force and sub-contractors on site. Each member of staff performed these activities across the entire site.

It was, however, reported that the visiting Contracts Manager performed a more direct role in placing sub-contract and new supply orders, and in dealings with sub-contractors on site (in conjunction with the Site Agent). He also attended the contract meetings held with client staff and sub-contractors' representatives described below. Consequently there was perhaps a greater degree of involvement by supervising head office staff on the MES project than that described in the earlier case studies (the RAW and AFU).

8.8 The Client's Supervision

The monitoring of the work on site on behalf of the client was undertaken primarily by the Job Architect, who had been involved in its design. This was the third (and final) architect to be employed on the project (see above). According to the Job Architect, he had first become involved during the main contract tendering stage, and was to follow the project through to completion on site. Supervising the work in conjunction with the Job

Architect were the Structural and M & E Services Engineer.

All three staff were involved part-time on the project, and visited the site on a regular (approximately weekly) basis (the Structural Engineer only until the completion of the basic structure of the building in the first half of the programme). In addition to these in house staff, a visiting PQS representative visited the site to evaluate the work, and attend contract meetings.

The daily supervision of the building work was undertaken by a resident Clerk of Works. The Clerk of Works would be involved for the full duration of the construction stage. However, he was not employed full-time on the project: during the course of the MTS project he was involved directly in the completion and handover of two other jobs being run by the BSO. The Clerk of Works had been seconded from the CDD's 'works' department by the relevant departmental head, on the "request" of the architectural Project Manager to provide a building supervisor for the team. During the course of the MTS project, his involvement in its supervision would come under the direct jurisdiction of the Job Architect.

In addition to the (building) Clerk of Works, a full-time resident M & E Clerk of Works was involved in the supervision of the M & E services installation on site. He had been seconded from within the CDD's M & E Department, and reported directly to the supervising M & E engineer, being involved only part way through the contract and through to its completion on site. Consequently a 'parallel' structure for supervision of the M & E works existed in conjunction with the structure established for

the supervision and monitoring of the basic building work' (see Figure 8.3).

In relation to the structure of authority within the client's team, the Clerk of Works was not empowered to issue instructions directly to the contractor, without first obtaining a formal site works order from the Job Architect. The Job Architect in turn issued all instructions pertaining to both the main building and mechanical and electrical engineering services work. According to the BSO's formal procedures, the Job Architect was required to "consult" with the Project Manager over the issue of instructions involving variations to the work that had financial implications and involved spending funds earmarked for contingencies. In relation to the main contractor's programme of work, the Job Architect also formally approved the programmes that were submitted, and was empowered with the authority (subject to the Project Manager's approval) to negotiate any extra time extensions to the contract according to Clause 6 of the GC/Works/1 form of contract.

The main formal forum for monitoring progress on the job was a monthly contract meeting that was held on site. It was attended by the Job Architect (who chaired the meeting), the two Clerks of Works (building and M & E), and the Structural and M & E Engineer, together with the visiting PQS consultant, on behalf of the client. (A representative from the user department also attended these meetings.) The Contracts Manager and Site Agent attended the meeting for the main contractor, and it was also noted that an office representative from each of

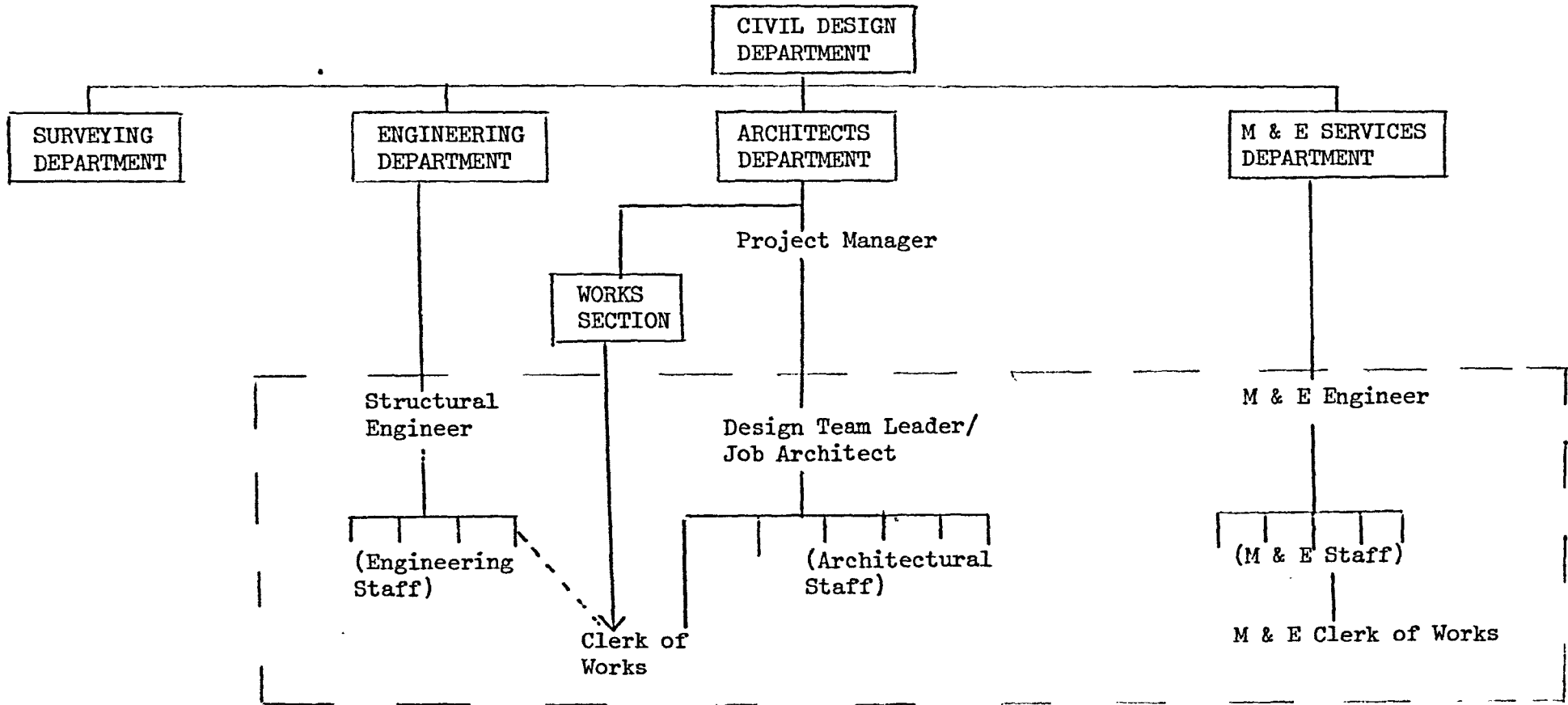

Figure 3.3 The client's in-house 'project management team' on the MTS project and relationship to 'head office'

the nominated services sub-contractors were also present. The items on the agenda included a report on progress, based upon the (building) Clerk of Works own report, rather than that given by the main contractor; requests for detailed design information by the contractor; design and construction details concerning the nominated work; and issues generally raised stemming from the design team members' inspections of the work on site. The details of the meeting were minuted and distributed to those in attendance, as well as to more senior (head office) staff from each of the organisations involved.

8.9 Performance on the MTS Project

As noted in Chapter 5 above, most of the accounts given of the course of events on the MTS project - and which are reported in this section - were given retrospectively, and at a relatively late stage in the project's course. In fact visits to the site continued beyond the planned completion date, and through to its eventual actual completion. The job was eventually completed eleven weeks late, only about three of which were reported (by both client's and contractor's staff) as being due to inclement weather, and the rest due to extra work for which extensions of time had been granted. It was also reported that additional extra work had been ordered (involving the installation of specialist equipment and corresponding adjustments to the structure of the building) and that this had been taken out of the original contract to be undertaken as an additional contract by the main contractor over a three month period after work on the original contract had finished. Excluding this aspect of the project, it was reported by members of the client's staff that the work on the MTS project had run approximately 10% over the original contract price - a good proportion of which was due to variations and additional work ordered by the client. Consequently, the project was one in which, allowing for the effects of weather and changes by the client, the time and cost targets for the work had ostensibly been met. This was reflected in the level of satisfaction expressed by representatives of both parties at the outcome in these respects. The main contractor's staff reported that they had experienced no problems in obtaining recompense or extensions of time to perform the additional work, and that the actual level of profit obtained on the job was 5% (less overheads).

The client's supervisory staff similarly reported their satisfaction with the time and cost targets achieved on the job.

At the same time, however, it was reported - by both parties - that problems had been experienced in achieving the specification for the work. This was due to problems in co-ordinating the structural and engineering services designs for the work, and in integrating the services work during construction. While this had neither directly affected the overall performance of the job in terms of its time or cost targets, nor the level of satisfaction expressed at the quality of the finished product by both parties, it was agreed that it had led to some problems in the relationship amongst the main participants on site and had led to a situation in which at least one claim for delay (by the subcontractor supplying the windows) was currently being processed. The volume of additional main building work associated with the installation of services and specialist equipment which had been taken out of the original contract was also regarded as being partly a consequence of the problems that had arisen in the integration of the services work.

To the main contractor's staff the main problems they had experienced had arisen once detailed working drawings for the services became available. Both the Site Agent and Contracts Manager reported that there had been many instances in which the drawings eventually established by the M & E engineer and the (relevant) subcontractor had been inconsistent with the architectural specification for the work. In instances where that work had already been constructed, integrating the services had involved making adjustments to allow for their positioning and routing (eg drilling extra holes

in the main frame to accommodate electrical cables). To the main contractor's staff the problem had been one of getting detailed information for the services work sufficiently early enough to make allowances when constructing the main building work. This was in a situation in which the drawings submitted by the subcontractor were often late. The Site Agent reported, for instance, that: "(the subcontractors) weren't obliged to produce full detailed drawings until the tender stage. The drawings were late through ... and we had to keep pushing for them ... (The subcontractors) were very late with drawings and this was still happening at the end of the job". This factor was also identified as the main reason for an 18 week delay in the installation of the windows - a delay which, however, was not 'critical' to the overall completion. This event will be returned to in more detail later on. The point to be stressed at this juncture is that the main problems were viewed as occurring in the designs and co-ordination of designs for the M & E work. Members of the design team agreed that there had been a problem, although the emphasis was rather more upon the perennial difficulties associated with integrating services work, rather than the problem being specific to the MTS project as such. The Structural Engineer noted, for instance: "The problem is that, when the structure's going up, its very difficult to get any information from the M & E and M & E subcontractors (on their) design details ... so we don't know how its going to affect the structural work until it does". The consequence, as far as the main contractor was concerned, was that a lot of the detailed design for the work "went by the board" (Site Agent) because the M & E "hadn't been allowed for". Despite the detailed architectural specification for the works, the Site Agent reported that the absence, until well into construction, of

detailed designs for the M & E work meant that in many instances the specification was "useless" and "impossible to work to". Those interviewed felt that the problems in this respect had neither proved 'critical' in affecting the process of construction, nor were they untypical of the types of problems faced in the construction of a building with a significant and intricate services component. However, they did feel that the problems experienced were somewhat unusual in that they reflected the distinct characteristics of the form of organisation and process of management adopted by the BSO to undertake projects. The reasons given for these factors being identified will be turned to next.

§.10 The MTS Project: A Case Analysis

What is interesting about the difficulties experienced in the co-ordination of the engineering services' designs for the MTS project, is the manner in which they were perceived - by all parties - to be a consequence of characteristics of the organisational context within which members of the design team operated. There was also an emphasis placed - again by all parties - upon the impact that the form of main contract agreement (ie GC/Works/1) had upon the process of design co-ordination. Before turning to and examining these points in more detail, however, it might first be useful to report the comments made which indicate the perceptions held of the level of co-ordination achieved, the expectations against which these were based, and the reactions of those interviewed to the situation.

From the main contractor's perspective, the situation had been

one in which the Job Architect - whom they expected to perform the central role in the co-ordination of the design work - had not been fully involved on the M & E side, and often unaware of alterations that had occurred in the M & E designs which had implications for the overall (architectural) specification for the building.

According to the Site Agent, for instance, the Job Architect had "turned a 'blind eye' to the engineering drawings". He felt that the Job Architect did not have "much appreciation of what the M & E work meant. He didn't get fully involved in that side and perhaps should have". Both the Site Agent and Contracts Manager described instances in which the Job Architect had expressed surprise at how the M & E work turned out to illustrate the point. The Contracts Manager, for instance, reported: "When the architect actually saw what the M & E work was, he was astonished - and we were astonished that he hadn't known". The Site Agent in describing the same event, reported that the Job Architect "threw up his hands in horror". To both members of the contractor's team, the Job Architect had tended to avoid the responsibility for co-ordinating and integrating the M & E design work. The Site Agent felt that the Job Architect had tended to 'rely on others': "the architect expected everything to be pointed out to him ... (and so) 'snags' (in the design) weren't picked up early enough". The Contracts Manager made a similar point in describing the responses given to their own requests for clarification of design information: "He would tend to say 'I don't know, that's the M & E division ... (He would) just let the other divisions get on with their work". Both felt that this left them with a problem in getting information and design decisions from the design team. The Site Agent suggested: "It left us in the dark about what to do ... and it was very difficult to get any

decisions". An additional effect that was reported suggested that the main contractor's staff were left with no single point of contact with members of the design team: "... we always tended to deal (separately) with the (individuals) concerned, and this caused a lot of problems" (Site Agent). In other words what appears to have happened is that the main contractor tended to have to deal directly with the M & E engineer (and subcontractors), but without any clear indication of the likelihood of acceptance or rejection by the architect of the designs for the M & E work in relation to the architectural specification for the job.

In part, this outcome was attributed to a conscious strategy adopted by the architect to put the responsibility for co-ordinating subcontractors' drawings onto the main contractor. The Contracts Manager, for instance, suggested: "Normally all the main contractor has to do is make the right structural openings for the (M & E work) from the architect's drawings ... But the (BSO) tried to push the responsibility for co-ordinating subcontractors' drawings onto us ... This isn't our responsibility ... We had a lot of problems arguing with the architect that this wasn't the case". This issue will be returned to shortly, as will the observations made by the main contractor's staff that it was the internal structure of the design organisation that was at the root of the problem. The Site Agent, for instance, proposed that the problem lay in the fact that members of the design team were all "on the same level as the (Job) Architect". The Contracts Manager similarly directed attention towards the fact that the Job Architect had not enough authority over the M & E engineer. The point to be stressed at this point is that the main contractor's perceptions that co-ordination amongst

the design team was less than desirable was linked by them to the perceived lack of involvement of the Job Architect in co-ordinating the M & E side - a situation that contrasted with their expectation that the Job Architect would and should play a more direct part in co-ordinating the work.

The observation that there had indeed been problems in the co-ordination of designs for the MTS project was corroborated by the Job Architect (and also by the structural and M & E engineers who were involved at later stages in the project). In doing so, a good deal of stress was placed upon the impact that the structure of roles and relationships amongst members of the design team had in creating the potential for the problems described above. The problem was not one that was viewed as specific to the MTS project, although it was agreed that the level and intensity of services work involved on that project was such that the problems were probably exacerbated. The contractor's perceptions that the problem lay in the formal relationship between Job Architect and M & E engineer were corroborated and expanded on more fully by the Job Architect who contrasted the situation in the BSO with that found elsewhere: "In private practice, M & E's depend on the architect for work ... (they) have the incentive to communicate more and prepare the design (more fully) ... The architect has more authority. In the (BSO) the M & E's aren't sufficiently responsible to the architect". Noting that the M & E's were not appointed to the team by the architect, he suggested that problems of co-ordination stemmed from a difference in orientation or 'attitude' towards working on specific projects: "Because they have the pressure of a lot of work, their attitude is more one of

'let's get this one finished - and any problems can be sorted out later on on site' ... (that's) with the result that you don't really pick up the problems until the job's built". Describing further the implications for working relationships amongst members of the design team, he then went on to suggest that an element of negotiation was involved: "The attitude is more one of 'if you want it done again, you'll have to pay for it' ... (ie) increase the fees to the M & E's for redesign". The lack of any direct formal control over the M & E design process was further hinted at in the description given by the Job Architect of the reaction to his attempts to exert more direct control on the MTS project: "... I had to take on a leading role - to get the team together - and get involved in the M & E side ... It caused some bad feeling at the time, but I think it helped to sort out the problem". In other words, the Job Architect playing a greater part in co-ordinating design work was a response to a problematic situation that had developed and not an underlying expectation or predisposition. Unlike members of the contractor's staff who held the view that the Job Architect would and should perform this role, the Job Architect, in describing the organisational realities, focused upon the factors that constrained his ability to do so.

It is interesting to note that this perception of relationships within the design team members on BSO projects generally was confined to the relationship between architects and structural engineers on the one hand, and M & E engineers on the other. The Job Architect stressed that this was not generally a problem that occurred with the structural engineers - a view that was shared both by the Structural Engineer (who was the last to be involved on the

MTS project) and by members of the main contractor's staff who were interviewed. The problem was one that was seen as occurring in the relationship between 'structural' and 'services' design representatives rather than between all members of the design team. The Structural Engineer who was interviewed confirmed that problems had occurred on the MTS project in this former respect, and that they were symptomatic of more general problems in the BSO's organisation of project teams. Interestingly, he suggested that the reason why the relationship between architects and structural engineers within the BSO was much closer than that between either group and the M & E engineers was due to their shared concern with the same aspects of the work on a project - ie the main structural work. This suggested a further factor contributing towards the divergence in perspective or orientation towards specific projects identified by the Job Architect in the comments reported above. A similar point was made by the Job Architect who, in describing the very close working relationships that tended to develop between the M & E engineer and the subcontractors concerned, suggested that: "When M & E engineers get together they seem to have their own logic". What these comments appear to suggest is the existence in general of a 'communications gap' between services design engineers and other members of the design team, and a high level of dependence upon the technical contribution made by the M & E design engineer. However, at the same time, such a degree of dependence on the performance of this function was not viewed by other members of the design team as being offset by an appropriate structural arrangement that would allow for the effective co-ordination and control of that work in pursuit of the overarching objectives for the project.

From the Job Architect's viewpoint the potential for co-ordination problems was also exacerbated by the practices employed by the BSO in the secondment of design team staff to individual projects. He felt that the tendency for individual designers' involvement to be brief (as noted earlier, five M & E engineers had been involved on the MTS project) mitigated against the integration of M & E engineers into the team. (The same was true of other design team members, although the points made earlier suggest that it was the divergence in orientation between 'structural' and 'services' staff that made this relationship more critical.) As well as ascribing the problems to the effect that brief involvement had upon the level of 'commitment' to individual projects, the Job Architect also suggested that designers' different 'styles' or approaches to the work made matters more confusing. This point he related directly to experiences on the MTS project: "... each individual M & E engineer (like architects and structural engineers) has their own way of doing the job ... (which) made it difficult on the MTS job". Specifically he described the influence this had had upon the performance of one particular aspect of the job: "... (the predecessor to the current M & E engineer) designed his work how he wanted it, and even disagreed with the client ... He had the effect of putting back the job a few weeks ... because he insisted (that a certain function) could not be performed, rather than trying to find a way in which it could be performed". The point here is that each designer's individual approach also contributed towards making a consistent approach to the design for the work hard to achieve. He further suggested that the degree of M & E involvement in subcontractors' detailed designs tended also to reflect the individual's "attitude" towards getting involved in design detailing and co-ordination. Linking these points with the earlier comments

concerning divergences in perspective amongst members of the design team, it is perhaps then not surprising that problems were identified in a situation in which the volume of services work involved was considerable, and in which the designs for that work were to be established in detail primarily during the course of construction.

While the discussion so far has concentrated upon the internal organisational context of roles and relationships amongst members of the design team, attention needs also to be directed towards the perceived impact of the form of contractual arrangement between the BSO and the main contractor. It should be re-stated at this point that the GC/Works/1 form of contract makes no provision for 'nominated' subcontractors. Instead the responsibility for all aspects of subcontracted work - including the co-ordination of sub-contractors' drawings - is formally the main contractor's. The client's agents are not formally responsible for checking or approving the designs submitted by subcontractors. This contrasts with the position under a more 'standard' (JCT) arrangement, where the formal nomination of subcontractors and their employment under a specific set of contract terms and conditions (the 'green form') implies a much closer relationship with the design team in the establishment of detailed designs and specifications for the work. In the accounts given of events on the MTS project, a good deal of attention was directed towards this factor as a significant underlying reason for the difficulties experienced on the project in the co-ordination of the services and structural work. Specifically - and somewhat paradoxically - in the ambiguities that it created in the responsibilities of the respective parties for the co-ordination of subcontractors' designs (for those subcontractors performing work

for which they would ordinarily be formally nominated under a JCT arrangement).

Reference has already been made to the view - expressed by the main contractor's staff - that the design team had tried to "push the responsibility" for co-ordinating subcontractors' drawings onto the main contractor. From the design team's viewpoint, their approach to the issue was informed by the expectation that the tendency would be for the main contractor to avoid their contractual responsibilities under GC/Works/1 in this respect. The M & E engineer, for instance, reported that: "... (main) contractors try to get out of the responsibility of co-ordinating the M & E services". A similar point was made by the Job Architect in relation to the designs for the structural work undertaken by subcontractors. He suggested that main contractors did not generally realise the full extent of the difference in working under the GC/Works/1 form of contract. One implication he described was the tendency for there to be, in practice, a greater degree of involvement of members of the design team in checking and approving subcontractors' drawings. The Clerk of Works made a similar point when he suggested that main contractors often "don't bother" to fully check and approve subcontractors' designs, and "rely on the (BSO)" to perform this function. These comments were made as general comments and not restricted to either the M & E work or the MTS project. They were also applied to circumstances on the MTS project in relation to the designs prepared by subcontractors undertaking the structural and finishing work - an issue that will be returned to shortly. In relation to problems on the M & E side, the Job Architect reported that the effect of the (earlier mentioned) M & E engineer becoming

more directly involved in detailing subcontractors' designs had been to "cut out" the main contractor from performance of their co-ordinating role on the project. The point to be emphasised here is that - in respect of the designs for the M & E works - the situation appeared to be one in which there were very different perspectives held of the responsibilities of each party towards co-ordinating the relevant designs for the work. The de facto greater involvement of the M & E engineer(s) in this activity, in response to the expectation that the main contractor would tend to avoid their de jure obligations under the contract compares interestingly with the argument put forward by the Contracts Manager that this activity was not their responsibility anyway. What this appears to suggest is a divergence between the formal and extant patterns of working relationships relating to the management of the M & E design process. In other words, the type of arrangement actually established was one that perhaps was closer to the type of arrangement found under more 'standard' (ie JCT) conditions. Linking this in with the earlier discussion of co-ordination amongst members of the design team, the implication appears to be not that this contractual arrangement by itself was necessarily problematic, but that it became problematic given the perceived lack of centralised co-ordination and control of the total design process within the design team. Yet at the same time the organisational features of the design organisation, coupled with the clear formal emphasis placed upon the main contractor in co-ordinating designs in effect precluded architectural members of the design team from approaching the situation in any other way. In essence, both parties were 'by-passed' in the continuing M & E design process: the main contractor, acknowledging the close design relationship between

engineer and subcontractor, and preferring not to be directly involved in that process, was dependent upon the architect to co-ordinate that aspect of the design process; the architect, with relatively little authority or influence over that process, and given the contractual position, was expecting the main contractor to play a fuller part in co-ordination. In the absence of either party fully performing this role, the result was the difficulties in integrating the services components described earlier.

Brief reference was made above to the issue of design co-ordination for the architectural/structural work in the context of the GC/Works/1 form of contract not allowing for nominations. One specific example was given that compares interestingly with the foregoing discussion of the interpretation of responsibility for the co-ordination of M & E designs. The issue was centred around an 18 week delay in the installation of the windows which had not affected the overall completion of the work, although it had resulted in a claim being put in by the subcontractor concerned. The details were given by the main contractor's staff who reported it as an extreme example of the types of problems they had encountered upon the job - most of which moreover had been associated with the integration of services work rather than in the co-ordination of designs for the structural and finishing trades. Nevertheless, despite being a separate issue, it does serve to highlight some of the points raised in the above discussion concerning the 'grey area' of design responsibility, as well as to illustrate a distinction in the orientation of the parties towards design responsibilities in the architectural sphere.

The contractor's staff reported that the problem of the delay

to this work was in the main a consequence of the lateness of the design information supplied by the subcontractor concerned. At the same time, they reported that this problem was compounded by changes to the work that were introduced by the Job Architect as the detailed design for the work progressed. The problem they felt was that these changes were introduced in direct dealings with the subcontractor, rather than indirectly via them. This was with the consequence that they were left largely unaware of the changes that had occurred and therefore of the reasons for the delay. According to the Site Agent: "Because of these (incremental) changes (the subcontractors') drawings were delayed ... I think the subcontractors were probably covering themselves as well (and) were at fault ... and also at fault because they should have dealt directly with us ... But we ended up stuck in the middle, not knowing these changes had occurred and pushing for (the subcontractors') drawings". Their lack of awareness of the changes that had occurred is also illustrated in the Site Agent's description of the events leading up to the submission of the claim: "We went to (the subcontractor) and told him we were going to press a delay claim ... It wasn't until then that (the subcontractor) threatened to stop work and sent reams of letters ... saying that they were delayed by the architect ... (and that in effect) they'd had to completely redraw the scheme". A similar description of events was given by the Contracts Manager, who described the Job Architect's preference "to get directly in touch" with the subcontractor and for the main contractor to be "by-passed" as a consequence. From the point of view of the earlier discussion, the telling remark was made by the Site Agent, who described design dealings between the architect and subcontractor beginning during the tendering stage and carrying on

into construction, when: "the architect was putting through design changes, despite the fact that once we were appointed the subcontractors were our responsibility" (emphasis added). The point to be raised here is that such a view contrasts somewhat with the comments given earlier concerning the responsibility of the main contractor in co-ordinating M & E subcontractors' designs. In other words, the assumption that the design team members would be more directly involved in the co-ordination of work on the M & E side did not hold in relation to design dealings in the architectural sphere (specifically here in a component of the finishing work on the project). Here, it was expected that design dealings would be, and ought to be conducted via the main contractor.

Again emphasis was attached to the impact of the ambiguities latent under a GC/Works/1 form of contract. Specifically, the contractor's staff contrasted the involvement of the Job Architect in direct dealings with the subcontractor with the tendency on the part of the Job Architect then not to formally approve or check the subcontractor's drawings. The Site Agent noted that: "(The architect) seemed very reluctant to approve windows, and we had to approve them according to the drawings supplied to us". In the Site Agent's view this compounded the problem of variations introduced in the work. A similar point was made by the Contracts Manager, who referred to the architect's ability to cross-refer to drawings and the specification for the work, whereas the main contractor, in the absence of full information concerning the updated design, was going solely from outdated drawings. The point to be emphasised here is that, on the one hand, negative connotations were attached to the perceived tendency for the architect to deal directly with the subcontractors

in introducing changes (in contrast with what was expected under GC/Works/1); on the other hand, negative connotations were also attached to the perceived tendency for this not to extend to checking and approving designs that were submitted (in accordance with what was expected under GC/Works/1). In other words, the extant pattern of involvement in relation to the design process (for the windows) consisted of a mixture of departing from and adhering to the formal pattern made explicit in the GC/Works/1 form of contract. In the contractor's view, this mixture represented the worst possible outcome: reference has already been made to their concern at being "by-passed" by the architect; the view was also expressed - by the Site Agent - that a departure from the formal arrangement in checking and approving designs, however, would have been more appropriate:

"... the architect has to get involved - even voice some approval of detailed working drawings ... because in the end the building is his responsibility. He has to pass it at the end of the day ... There's also the problem that is a matter of personal taste (which will determine) what he accepts or rejects ... (this means) in practice you do need some indication of approval (or rejection)".

Taken in conjunction with the earlier comments made concerning the parties' expectations of their own and other's roles in the management of the design process, and their consequent orientation towards that process, a strong impression emerges that each party was trying to 'have things both ways'. While the formal contractual position made clear the respective parties' obligations for co-ordinating subcontractors' designs, the actual pattern of involvement in this respect appeared to derive rather more from expectations about how each other would approach the issue based upon experiences of working under a more standard form of arrangement.

Yet, at the same time, the formal position also informed the parties' approach towards one another. To the main contractor, the Architect informally "by-passing" them but formally withholding approval was a double sin; to the Architect, given their own expectations of the role that the main contractor would perform to do neither would have also been a double sin.

Before leaving this issue, it should be briefly noted that further reference was made to the impact of internal relationships within the client's team - specifically to the relationship between Job Architect and Clerk of Works - in the situation in which the main contractor was faced with the problem of obtaining design information, drawings and instructions. Both the Site Agent and Contracts Manager made explicit reference to the Clerk(s) of Works lack of authority to issue instructions and lack of awareness of changes that had occurred (in both the architectural and engineering services work). The Site Agent, for instance, expressed the view that: "... (they were) put in a difficult position (because of) the limit to the decisions they could make ... (they) could only go back to the architect for approval". Similarly the Contracts Manager who also noted that: "(the Clerks of Works) were in the same position as us - not knowing the full specification and working to drawings". In terms of the position of the Clerk of Works who supervised the building work, a contrast was then drawn between the limits to his authority and the degree of influence he exerted in the running of the job. The Contracts Manager stated, for instance: "The Clerk of Works, as normal, tended to run the contract ... A major difficulty was that he (being in control) kept on changing his mind (as to) what he wanted ... But he didn't have the authority to make the

decisions - (he) had to refer constantly back to the architect for approval ... This caused delays". The point to be made here is that the role-holder perceived as having perhaps the most direct influence over the process of construction on site was viewed as having insufficient authority to back that influence. This was viewed by the main contractor's staff as not only not helping the situation, but as a positive hindrance, since it added to what they viewed as the already fragmented control exercised by the client's representatives over the process of construction on site.

Before leaving the MTS case, a final point needs to be made concerning broader strategic factors that informed the approach adopted towards the contract. The main contractor's Contracts Manager expressed directly the factors that had made this job an "important" one to the firm. Firstly, he regarded the job as a 'prestigious' one - due to the publicity that the firm would get from having been involved in the construction of a custom-designed laboratory building with complex services. Secondly, and more importantly from the viewpoint of this discussion, he related its significance to the fact that the BSO was an important client, and to the need to restore the company's 'reputation' which had been jeopardised on a previous project with the BSO in which similar problems as those reported on the MTS project had occurred. He reported that: "Originally, after the previous job (for the same user establishment), the BSO didn't want us - even though we put in the lowest price ... because the job went badly and we got the blame ... We went through the whole rigmarole of interviews (etc) to get our tender accepted ... (because) we wanted the job and were determined to prove to the (BSO) that it wasn't our fault ... (that)

we'd been unfairly maligned". The manner in which this was converted into a strategy for coping with expected circumstances on the MTS project was then made clear in the following quote: "It (the MTS) was not as bad as the previous job (had been) ... (the Site Agent) was told to keep on nagging until a decision was reached, (not) let them make it in their own time ... We'd learnt from the other job that we would have to keep at them ... make a stand and ask for details of all alterations ... whether or not these were likely to cause any effect". Their success in achieving this objective was summed up by the Contracts Manager in reporting the architect's acceptance of the outcome at the end of the job: "In the end we submitted a list of VO's to the architect ... distinguishing between (those caused by the architect changing his mind) and (those caused by the client changing their mind) ... (The Job Architect) simply removed (the former) and just listed (the latter) when recommending an extension ... so far we haven't heard anything, so it must be OK". Unfortunately no comment was made by the Job Architect in relation to this outcome, although it was noted that whereas the Site Agent and Contracts Manager both reported that there had been in the region of 700 - 800 variations to the work during the course of construction, the Job Architect did report that there had only been 57 variation orders placed. The important point is rather that the contractor's previous experience led to them adopting a conscious strategy to avoid what would otherwise have been a less desirable outcome than that they actually felt they eventually achieved on the MTS project.

9.1 The Project, Client and Context

This project involved the construction of a set of three inter-connected buildings which were to serve as part of a new school of sciences for a polytechnic. The work was being undertaken by a local authority (the County Council) as client acting on behalf of the users of the facility, and was financed through local government funds. Each of the buildings was to be three storeys in height and measure 50 x 30 metres, yielding a total floorspace of some 12000 m², to be used for laboratories, lecture rooms and office accommodation for teaching and administrative staff. The location for the NSS was on a formerly unoccupied site within the existing campus grounds of the polytechnic, but well away from existing occupied buildings.

The construction of the NSS project was part of a 'one-off' development of the polytechnic's scientific teaching facilities. It represented the first stage in a two-stage development of the school. The second stage, involving the construction of 'twin' blocks adjacent to it, would follow on after completion of the first stage. Building on the second stage would be due to start about a month after completion of the first. The occupation by staff of the first stage buildings was to occur after full completion and final certification of the works on the three buildings and to coincide with the initial phases of construction in stage two.

4/25/57
The County Council, as client, controlled a total annual capital expenditure on building work in the region of £6 million. The scale of the NSS project was relatively small in value terms: it was budgeted at approximately £1.3 million, to be spent over a two year construction period. (The second stage works were budgeted lower at £1 million to be spread over a 15 month period. These buildings would house fewer laboratories and consequently be less 'services-intensive' and less costly.) However, the project, and the development in total, represented a sizeable investment in relation to the Council's total expenditure plans, and constituted the largest single current new building project being undertaken by the local authority at that time. 

9.2 The Client's Representatives

The work associated with the design and supervision of the NSS project was undertaken in house - within the County Council's own Architects Department. The Department overall was headed by the County Architect, who reported directly to the County Council. *owner*
In total the Department employed approximately 140 personnel, consisting of around 36 architects, 26 surveyors, 13 electrical and heating engineers, 8 quality control inspectors and about 30 administrative and clerical staff. Staff were grouped within two main divisions: an Architectural Division, whose members were involved directly in broad and detailed planning and design work and supervision of projects during construction; and (a Surveying Division), whose members were involved in the administration of contracts, and which was responsible for the allocation of personnel and resources around the Department generally.

It was noted by senior staff within the Department that current staffing levels represented about a 30% reduction in employment compared to the levels of only three years previously. It was suggested that this reduction corresponded to a 50% fall in the volume of work handled by the Department over the same period. This was attributed in the main to cutbacks in building expenditure by the local authority, coupled with an increasing tendency on the part of the County Council to sub-let more design work to private consultants, rather than to provide in-house design services to cope with additional demand. The Department nevertheless continued to undertake most of the work commissioned by the local authority, and at the time of investigation controlled an annual budget on building work of around £6 million.

The NSS project (and the development as a whole) therefore represented quite a sizeable venture, in relation to the Department's total activities. Indeed, it was the largest single project being currently undertaken. Moreover, it was the first major project being done on behalf of the polytechnic, which had previously hired private consultants to design the majority of its new building work. Success on this project would increase the likelihood of the Department obtaining future work from that source.

At this stage it should be noted that an important feature of the NSS project (and the second stage buildings) was the use of a 'system' method of building. That is, the structural components of the building were to consist in the main of components that were fabricated off-site and then delivered and

assembled on site, as apposed to being constructed in situ. This was to be so for the basic steel frame of the building, together with many of the internal walls, doors and partitions. The main in situ structural work would be limited to the concrete floors, roofing and external (brick) cladding. The use of a 'system' method of building was a long-standing policy of the Department. Indeed, it was noted that a proportion of the professional fees earned for design work was contributed towards a consortium of suppliers who were involved in developing that particular system. According to senior staff within the Department, a system method was used because it was felt that dealing with component suppliers rather than building sub-contractors contributed towards higher productivity. Its use across the full range of departmental work was the reason why the department employed no structural engineers.

For the design and supervision of the mechanical and electrical services work on the NSS project, two private consultants were employed - specialising in mechanical and electrical services work respectively. Both firms of consultants were small local practices, which had had a good deal of experience in working for the County Council, which in turn constituted the major client for their services. The employment of the consultants was controlled by the relevant local authority client committee, (ie education) and contractual arrangements with them were handled by the Surveying Division.

9.3 The Main Contractor

The main contract for the construction of the NSS works was

let to Steelframe Ltd - a local firm registered as a general building contractor. It was a small firm whose turnover in the two accounting years that fell between the start and finish dates of the NSS project stood at £2 million and £1.6 million. In the latter year, pre-tax profits as a proportion of turnover stood at 4% compared to 12% in the previous year. Its fixed assets stood at £90,000 and net current assets at -£50,000. It employed a total office staff and site-based workforce amounting to only about 60. It operated exclusively within the region in which it was based.

Over time the firm had done a good deal of work for the County Council and had had experience of working with the Architect's Department and were familiar with their systems and methods. The company Surveyor estimated that, on average, about 80% of their work consisted of council contracts. The NSS contract was at the time also the largest single contract that Steelframe had on their books, and represented a very sizeable proportion of their total annual turnover.

9 :4 The Design Process and Design Organisation

The brief for the NSS project had been supplied by the poly-technic on behalf of the users of the facility (the particular departments), and described the requirements for teaching accommodation, laboratories, offices and communal areas, and various other facilities and amenities to be provided. The design process had then involved the appointment of an architectural group leader to act as Project Manager, and to prepare an outline

design proposal to the brief supplied. Following the acceptance of the design proposals by the polytechnic, and the local authority treasury and client committees, the detailed design stage for the project had commenced with the secondment of internal staff and the appointment of the M & E consultants.

The pattern of involvement in design and the procedures used had followed the Department's normal practice in managing projects. Within the Department, it was the Architectural Division that constituted its 'line' management and which housed staff which were seconded to project teams. The overall management of particular projects, through from the establishment of design proposals to completion on site, was delegated to architectural group leaders acting as Project Managers. Their project teams would consist of architects working within their own groups. A Job Architect was appointed to undertake the detailed design for the work, and to monitor its implementation on site. Working with the Job Architect were a group of architects and technicians. Both the Project Manager and Job Architect followed the project through design and construction stages, rather than there being any separation of the design and supervisory roles between stages. The latter would be involved full-time on the project. There was no formal specialisation within the division - either as a whole or within particular groups - according to the type of work involved. Instead, staff availability formed the main criterion for the placement of individuals on particular projects, and the size of the team and level of staff involvement would then largely be dependent upon the size of the individual project.

Other specialist staff (ie engineers and surveyors) would be seconded full-time to these teams on a job-by-job basis from specialist functional sections within the Architectural Division. Their appointment again would depend upon availability, and would be made by the appropriate section head. Their work on the project would then come under the formal jurisdiction of the architectural Project Manager. Consequently, staff were seconded directly to the project team to work under the supervision of the Project Manager, rather than acting as 'consulting' staff to the architectural team. For the NSS project, a surveyor was seconded to the team from the surveying group within the Architectural Division, and was made responsible for the financial monitoring and evaluation of the work on site. The work associated with preparing initial costings and contract documentation and the management of the tendering procedure had been undertaken by surveyors from the Surveying Division. This Division would also be directly involved in the post-site administration of the contract (final payment, claims negotiations, etc). Consequently, there was a distinction within the department between the roles performed by surveying staff: specifically there was a separation of surveying functions associated with supervision during the course of construction, from the broader planning and control functions associated with pre- and post-contract administration. An additional function that the Surveying Division undertook was concerned with the allocation of staff and resources within the department generally. This latter function extended to the Division's general responsibility for the training and career development of surveying staff working in the surveying team within the Architectural Division. Consequently

the Division performed more general 'maintenance' functions within the department as a whole.

During the detailed design stage, it was the Project Manager who was involved most closely in the co-ordination of the architectural and engineering services designs for the building. The consultants were appointed at this stage to provide detailed designs to the brief supplied by the user, and within the context of the architectural design proposal agreed with the various client bodies. According to the Project Manager, during this detailed design stage fortnightly design meetings had been held to deal with consultant's queries, and to co-ordinate the two aspects of the design for the project. He also reported that, at "appropriate points", in house specialist staff (eg heating/ventilating engineers) had been brought into the design process to "advise".

9 .5 Characteristics of the Design

The nature of the NSS project - as a 'one-off' development built to detailed client specifications - meant that the design for it was also a one-off undertaking. A similar broad design would be used for the second stage of the development. However, for the first stage, there was to be a considerable amount of new design work. Furthermore, the function of the new buildings as a science school, and the associated volume of work required in the building of laboratories as part of it, meant that the requirements for it were relatively services-intensive. The design was to allow for the installation of extensive mechanical and

electrical work, special facilities (such as glass drainage), and laboratory-specific fixtures and fittings (such as lab benches, fume cupboards, etc). Consequently the design for the buildings was by no means standardised, and a particular emphasis was placed upon the integration of the structural and engineering services designs.

At the same time, the use of a 'system' method of building did to some extent serve to standardise the design associated with the basic structure of the building. It meant that the specification for the basic buildings allowed for the use of standardised manufacturers' components, adjusted to take account of differences in dimensions. Furthermore, the construction of three basically identical buildings allowed for further standardisation of the structural design. In terms of the methods of building adopted, the use of the 'system' method meant a reduction in the volume of work on site associated with the main structural and finishing trades (eg bricklaying, joinery, plastering), and a much greater emphasis upon on site fixing and assembly of pre-fabricated components.

It also meant the use of relatively standard and familiar (to the designers and to the contractor) materials. The more standardised and routine features of the structural work for the NSS project, therefore contrasted with the more specialised materials and rather more job-specific fixing patterns and methods of building associated with the installation of the services work within the buildings.

According to members, both of the design team and the main

contracting firm, the amount of time that the design team had had available for the preparation of detailed working drawings prior to work actually starting on site had been very short. Consequently, the department had gone out to tender for the main contract with few of the full set of drawings that were needed being available. This meant that there was some degree of 'overlap' between the design and construction stages of the project: the preparation of detailed designs for specific aspects of the work, and the issue of a large number of detailed working drawings were to occur during the construction stage. It also meant the potential for variations to the work occurring, particularly in respect of the interrelationship between the structural and services components in the buildings. A more detailed description of this situation with an assessment of its perceived implications will be given below. The point to be made here is that there was no clear delineation between the design and construction stages of the NSS project.

9.6 Tendering and the Main Contract

The tendering procedure for the award of the main contract had involved a single-stage, selective competitive tender on the basis of a priced bill of quantities. According to senior staff within the Architect's Department, the practice was to select for tender locally-based contractors who had knowledge and experience of the Department's 'system' methods and procedures. The tendency then was to employ small local contractors who had a continuing working relationship with the council over time. It was estimated that, over the previous 10 - 15 years, the

Department had used only about six different contractors. It was also noted that, at any one time, the Council might be employing 3 - 4 local contractors. A similar approach - hiring small local firms who had in the past performed work for the council - was described in the selection of consultants. Given the factors accounted for in selection of tenderers, the decision to appoint Steelframe was made on the basis of the lowest submitted price for the job.

The subdivision of the total development scheme for the polytechnic school into two stages (and two separate contracts), reflected the council's practice of serial building. This procedure had been used over the past 20 years or so, and the aim was to reduce the volume of design work for subsequent stages of individual developments, and to allow for building experience to feedback into later design and planning processes. Coupled with the use of a 'system' method, the intention then was to 'routinise' work involved at the design and construction stages of the project cycle for further developments. This was particularly the case on the current project, in that the second stage of the NSS development would be structurally similar to the first, and the work involved be less services-intensive (there being no laboratories). By the same token, the use of serial building also ostensibly placed the successful main contractor in a favourable position for obtaining follow-up work. Indeed, towards the end of work on the NSS contract, Steelframe would be involved in tendering for the second stage of the development.

The main contract for the first stage was let under standard (JCT) conditions (the local authorities edition), and comprised these conditions together with the bill of quantities, specification and working drawings (both those already prepared and those to be issued during construction). The value of the contract was set at £1.3 million (with allowance for price fluctuations), and the specified period for construction was 104 weeks (April to April). The work was to be evaluated, and the issue of interim certificates and payment to the contractor to be made, on a monthly basis with a 5% retention withheld. Provisional sums had been set aside in the bill for contingencies, dayworks and additional work.

A significant proportion of the prime cost value of the work was to be undertaken by nominated sub-contractors, employed under standard (JCT 'green' form) conditions. Separate nominations were to be made for the mechanical and electrical services work and for the specialist installations. (It should be noted that a somewhat unusual feature of the organisation of the project was the eventual appointment, for the mechanical work, of the same firm which was acting as mechanical services consultant.) In addition to nominated sub-contractors, the use of a 'system' method of building meant that a number of suppliers were in effect nominated by virtue of their products being built into the specification for the works. All sub-contractors (nominated and domestic) were to be paid fortnightly, with a 5% retention withheld.

The programme of works which was submitted by the main contractor during tendering formed the basic plan for the construction

of the work within the contractually-specified time limit of 104 weeks. The three buildings were to be constructed in parallel: that is, they would be built up simultaneously, rather than the construction of one following on from completion of another. Within this broad scheme, work within each trade (eg the plastering) would tend to be done from building to building, rather than across the three buildings simultaneously, in order to allow for the smoother co-ordination of each of the trades on site. With much of the services, internal structure and fittings work being nominated or supplied by component, the main work performed directly by Steelframe was in the excavations, in situ concrete works and the internal and external brick and block work.

9.7 The Main Contractor's Site Team

The number of staff involved in supervising work on the NSS project on behalf of the main contractor was small, which reflected the relatively small scale of the project in financial terms (see Figure 9.1). The company's main representative on site was a Site Agent, whose 'team' consisted of a General Foreman, Trades Foreman and Site Engineer. Each of these staff were transferred from company sites elsewhere, and involved full-time and resident on the project.

The project was monitored from head office by a supervising Contracts Manager, who in fact was a director of the firm. His direct involvement was through regular and frequent visits to the site (on average, weekly),. In addition, the financial monitoring and evaluation of the work on site was undertaken by the company's

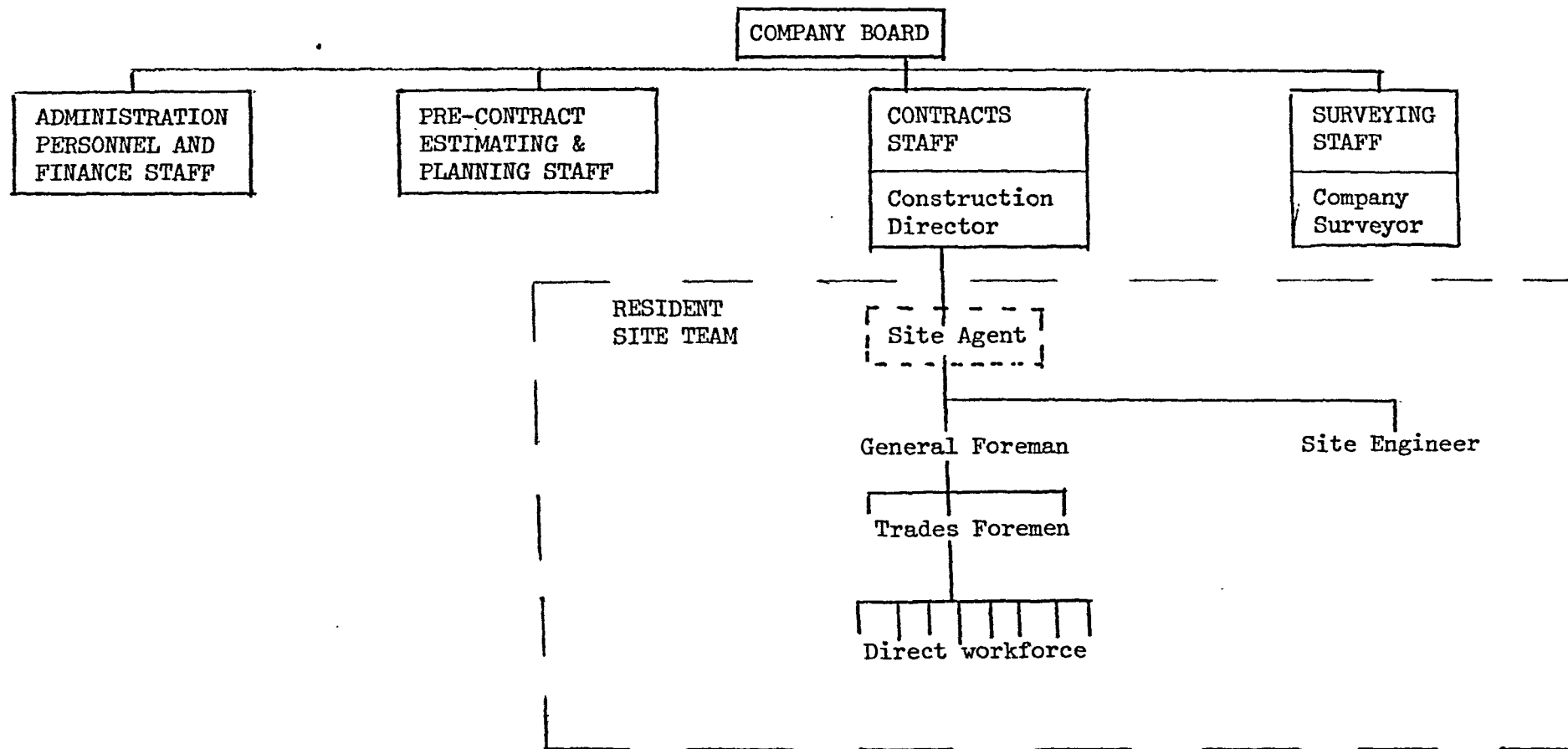

Figure 9.1 Steelframe Contractors Ltd: Site management team and relationship to head office

Surveyor who was based at head office, and who visited the site periodically to evaluate the work, (on average, monthly). Both these members of staff were involved concurrently in supervising other contracts held by the firm, and in planning and tendering for future contracts.

The involvement of the site staff did not in all cases continue through the duration of this project. The Site Engineer for instance, was transferred to another site once the basic structural work on the project had been completed. More significantly perhaps, the Site Agent left the project to work on another of the firm's sites at a relatively early stage in its development. Unfortunately this occurred well before the first fieldwork visit was undertaken. According to the supervising Contracts Manager, it had occurred due to 'problems' in the relationship between the site team and the client's representatives - although no specific details of this were given. In terms of the supervision of work on the project, it meant that the Contracts Manager became more closely involved in its running. Those who were interviewed from both the client's and contractor's side described the situation as one in which the Contracts Manager was acting in effect as a non-resident Site Agent for the company, while the General Foreman's role had been extended to undertake some of the work (in planning and resourcing the project) formerly undertaken by the Site Agent. In other words there was a shift within the organisation towards a greater 'supervisory' role on the part of the Contracts Manager, and a more 'managerial' role on the part of the General Foreman. Consequently there was a distinction

marked between the formal structure of management initially established to undertake the work on site and the actual pattern of involvement over the course of much of the period of construction. The pattern of involvement of the contractor's supervisory staff in the programming and resourcing of work was similar to that described earlier on the MTS project, with the exception that the supervising Contracts Manager performed some of the work undertaken by the Site Agent in that case - notably placing orders with sub-contractors and suppliers and agreeing or negotiating details of work, both with members of the design team and with sub-contractors and suppliers once they were appointed. His main role in the more detailed operational management of work on site therefore related to managing relationships with other parties involved in the project. Like the MTS project, this meant a closer degree of involvement by supervising head office staff than that described in the earlier case studies (ie the RAW and AFU).

9.8 The Client's Supervision

The monitoring of the work on site on behalf of the client was undertaken by the Project Manager and Job Architect who had been involved in its design, together with the Surveyor seconded to the project team, (see Figure 9.2). The Job Architect and Surveyor were involved full-time on the project, and visited the site throughout its course. They were not resident, but visited the site on a regular basis - the Job Architect came two to three times a week on average; the Surveyor less frequently, to undertake the monthly financial measurement of the work, and in

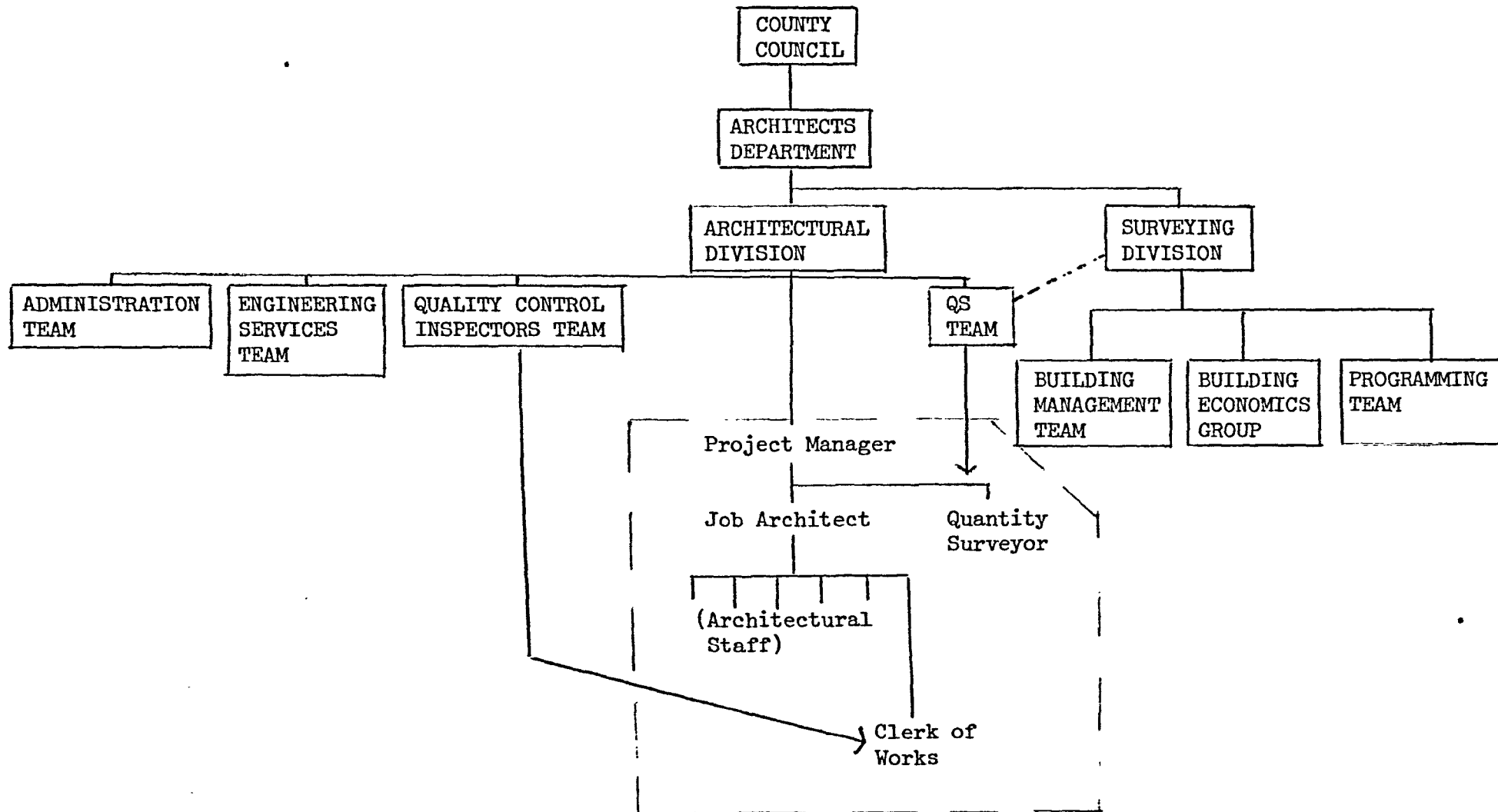

Figure 9.2 The client's 'in house' project management team on the NSS project and relationship to 'head office'

response to particular issues that occurred. The Project Manager visited less frequently (approximately fortnightly) and was not involved full-time on the project.

For the day-to-day supervision of the building work, a full-time resident Clerk of Works had been appointed to supervise the work throughout its duration on site. The Clerk of Works had been appointed from the departmental 'works' section which housed the department's 'quality control inspectors'. The secondment had been made by the section head and, as described earlier, the Clerk of Works' involvement on the project was to come under the direct jurisdiction of the architectural members of the team.

In addition to the in house staff involved in the project's supervision, senior representatives from each of the two consultancy firms were involved in monitoring the implementation of the M & E design on site. Both individuals had been involved in its design, and were backed up by a staff of design engineers based at their offices. They each visited the site on average about once a week. There was no M & E Clerk of Works appointed to monitor directly that aspect of the work on site. It was reported that the M & E consultants held their own meetings on site with representatives of the (nominated) sub-contractors performing the work.

As part of the Department's formal procedures for monitoring site activity, it was specified that Clerks of Works were not empowered to issue instructions to the main contractor, and that all instructions issued were to be done so in the form of architect's

instructions drawn up by the Job Architect. A similar procedure operated in relation to instructions issued concerning the M & E works. The Project Manager's approval was needed before instructions were issued involving variations to the work that had financial implications and which involved spending funds earmarked for contingencies and additional work.

The main formal forum for monitoring progress on the job was a fortnightly contract meeting that was held on site. It was attended by the Job Architect (who chaired the meeting), the Project Manager, Clerk of Works and Surveyor on behalf of the client, and the Contracts Manager and General Foreman (earlier the Agent) on behalf of the main contractor. The items on the agenda included a report by the main contractor on progress in relation to the overall plan for completion; contractors' requests for detailed design information; design and construction details of (nominated) sub-contractors and suppliers work; and general matters raised stemming from the design team members' and Clerk of Works' inspection of the works. The details of the meeting were minuted and distributed to those attending, to the M & E consultants and to more senior (head office) staff from the Architect's Department and County Council.

9.9 Performance on the NSS Project

As noted in Chapter 5 above, at the time of the first visit to the site, the project was approximately 75% complete, in terms of the programme of work. The external work, apart from landscaping, was finished; the structural work was complete; and most of the services had been installed. Most of the work that remained was in the finishing trades and the installation of fixtures and fittings. Consequently, at that stage the project was 'running down' to completion, although the participants mentioned above were still closely involved in its management. According to both client's and contractor's staff, the project was running approximately a month late. In terms of its budget, the Project Manager reported that the job was within the budget established by the client although most of the contingency fund set aside for variations and additional work had been used up in paying for design alterations.

It was in this latter aspect of the performance of work on site - namely, the establishment of a detailed design for the works and changes in it during the course of construction - that received prominence in the retrospective accounts given by those involved of performance on the NSS project. In the opinion of those involved from both client and contractor's teams, the job had been "untypical" (in relation to previous Council projects) in the extent to which detailed working drawings and design information had been unavailable for the early stages of construction, and also in the extent to which changes had occurred in the design during the actual course of construction. The Job Architect, for instance, reported that at the beginning only a small proportion of the working drawings needed were

available, since the period to prepare them had been short and a great deal of information had been required at the billing stage, which put pressure upon the designers and draughtspeople. He also reported that a significant proportion of the work had been originally billed as provisional sum items, and noted that with a good number of variations having occurred in the work, the design team were still involved at a relatively late stage (ie up to and beyond the first visit) in preparing detailed drawings and specifications and answering the contractor's requests for information. The same situation was reported by members of the main contractor's staff interviewed, who then went on to suggest that it had created significant problems for them in the construction of the work, and was a major contributory factor towards the delays experienced in the programme of work. The Contracts Manager, for instance, who reported that in his experience of working for the County Council and the Architect's Department this was an "untypical" situation, said: "we've had a constant problem with late information and delayed (design) decisions ... on this job its difficult to get decisions made and you're always pushing for information". He and his staff commented upon the difficulties this had created in holding back parts of the work on site and in hindering the process of placing supply orders in sufficient time to meet the programme of work drawn up. While agreeing that this had been a problem faced by the main contractor, members of the design team at the same time pointed to the part played by the main contractor in managing the flow of design information between the parties. The Job Architect, for instance, suggested: "I don't think Steelframe are very good at planning ... they don't seem to ask for information at the right time, and always seem to do it in a panic ... (also they) tried to

do too much at the beginning".

On the number of design variations that had occurred, the contractor's staff reported similar problems in the advance planning of work, and also occasions on which work had had to be redone when decisions were eventually reached. In terms of the implications for the firm, the company Surveyor expressed the view that the architects were unappreciative of the volume of extra work involved when changes were introduced, and that the contractor was, as a consequence, "always pushing" for payment. In terms of the performance of work on site, the Contracts Manager described the implications of the changes to the work on the level of 'morale': "its been so bad that many of our men have wanted to be taken off the job ... because they're fed up of doing work, and then having to do it again." To the Contracts Manager, the reason for there being delays in the issue of design information, and many changes as the work progressed lay in the lack of certainty on the part of the architectural design team as to what they actually wanted: "most of the bill was in provisional sums because they (the architects) hadn't decided what they wanted". Similarly, and as a consequence, "there have been an enormous number of VO's (variations orders) caused by the architect changing his mind". Interestingly, the architectural Project Manager provided corroboration of these comments - albeit in a somewhat oblique fashion. Moreover, he stressed that the lack of understanding was rather on the part of the main contractor, and the substance of it a lack of appreciation of the problems of, and constraints upon, design: "(the contractor) just doesn't seem to understand that its to be built the way I want it ... they don't understand the problems of design - that I can't issue an order until

I know precisely what I want". This lack of understanding was manifested in the tendency to respond 'contractually': "if there's no order, then (Steelframe) immediately put in a claim" (Project Manager).

It should be noted at this point that the problems referred to centred mainly upon the work involved in the finishing trades (decoration, etc) and in the external landscaping. The main structural work and, in particular, the mechanical and electrical services work, it was generally agreed had 'gone well'. Some problems were noted, by both architectural and building staff as having occurred in controlling the quality of the services installed, and in co-ordinating the services components with the structural work (the M & E consultants were not interviewed). Moreover, these problems were linked to some extent with the fact that the mechanical firm that was employed both installed the services and provided professional design services. The Job Architect, for instance, reported: "you're not sure who you're talking to - the subcontractor or the consultant". His view was that the situation tended to be 'used' by the firm in its dealings with the architectural team. Specifically that any 'snags' in the mechanical services design were either attributed as variations to the work for which the firm (as subcontractors) demanded extra payment; or they were attributed by the firm (as consultant) to the lack of detail in the original brief or as a consequence of the work having been designed with a view to the budgetary constraints established for it - in which case they demanded extra design fees to redesign the work. A similar view was held by the Project Manager, who suggested that the duality

of interest, coupled with only a broadly outlined initial specification for the M & E works, gave the firm (as consultants) little incentive to design to a "high quality" specification. This, he felt, was in order to make the work less complex (and less costly) for their builders. Any changes occurring on the basis of the architect's expressed dissatisfaction with the work as it was produced would then tend to be approached in the manner described above. This situation is of interest in itself, and will be returned to at a later stage. However, both Job Architect and Project Manager felt that the problem was not one that should be overstated in relation to the events that occurred during the course of the NSS project. In terms of the performance on the project overall, they, together with the contractor's staff felt that the performance of the mechanical subcontractor on the whole had been 'good', and that the services installation had created no real major difficulties during construction.

The point to be emphasised here is that it was work related to the architectural side of the job - specifically in the finishes and landscaping - that had produced the difficulties described earlier, and the resultant recriminations directed by each party towards the other. The extent of the difficulties experienced in the relationship between the design and construction teams was indicated by the contractor's Surveyor. In describing the contractor's relationship with the subcontractors employed on the project as "good", he then suggested that the main contractor and subcontractors had "united to fight the common foe". The underlying reasons that were given for this 'adversarial' state of affairs and the manner in which it was seen to have arisen, will be turned to next.

9.10 The NSS Project: A Case Analysis

In describing the NSS project and the course of events during its construction, a good deal of emphasis was placed by all those interviewed upon how 'important' and 'prestigious' the project was. In its size and the nature of the work involved, the project was not considered unusual or untypical by any of the parties. Yet there was general agreement that the project was unusual, and that this was due to its status as a major new building project being undertaken for a new client (the polytechnic). This was set in the context, described earlier, of a contraction in the capacity of the Architect's Department to design and manage Council projects, and the increasing tendency for the Council to contract out design services to private consultants. The implication of the importance of the project for the process of managing it was seen to be a significantly greater degree of centralised control exerted by more senior members of the architectural design team. The Job Architect, for instance, reported that: "there's more involvement at higher levels ... normally the Project Manager wouldn't need to visit the site". Similarly, but from the Contracts Manager's viewpoint, "the problem with this job is that basically there are too many fingers in the pie ... usually all dealings we have would go through the architect on site (ie the Job Architect) ... On this job too many senior architects are involved".

To the main contractor's staff, the problems they had encountered in obtaining detailed design information and getting decisions made, were directly attributable to the greater degree of involvement at senior levels, and, in particular, to the influence the Project Manager

exerted over the continuing design process: "(the Job Architect) seems to live in meetings, and isn't given the time to do his work (on design detailing) ... Information comes through very late because it all has to be approved by the Project Manager" (Contracts Manager). In their opinion, it was the tendency for the Project Manager not to delegate authority to his staff coupled with a lack of understanding of the detailed operational conditions on site that was at the root of the problem. The Contracts Manager said, for instance: "The problem is that (the Project Manager) isn't really involved - he doesn't really understand what's going on ... (yet) he has a lot of control over the Job Architect ... (who) hasn't the authority to make decisions and keeps having to go back to the Project Manager for approval ... (the Project Manager) interferes rather than gets involved and he doesn't delegate". To the Contracts Manager the Job Surveyor was "in the same boat", because "any cost implications have to go down the line for approval". In his view, the main manifestation of the problem was in the delays that occurred before design decisions - particularly those with cost implications - were given. In addition he described what he felt was the 'interference' of the Project Manager: "Because (the Project Manager) doesn't know fully what's happening, it causes problems ... (because) he'll come down on site and disapprove of something, because he didn't expect it to come out like that ... The problem then is getting information and instructions". He felt that this approach, coupled with the need to refer back for approval for decisions, put those most directly involved in the supervision of the work (the Job Architect, Surveyor and Clerk of Works) in a position of having to "cover themselves". The view was shared by the contractor's Surveyor, who directed attention towards the

tendency for members of the team not to commit themselves to decisions : "The architects are very unwilling to commit themselves and accept responsibility ... (they) don't put anything down in writing; don't issue AI's till its too late; ... (they) even omit items discussed and agreed in (contract) meetings ... (they) continually refer back". A similar degree of caution in decision-making relating to the centralised control of the client's team was identified by the Contracts Manager in their direct dealings on site with the Clerk of Works: "(The Clerk of Works is) experienced and knows that we're often right ... (but) he hasn't the authority to decide, or the power to stand up to the architect and tell him he's wrong ... He has to cover himself ... he can only say 'I can't accept that' or 'I've got to reject that' ... he can't make suggestions". From the main contractor's perspective then the problems they faced in obtaining information and decisions were a direct consequence of the level of control exercised over the running of the project from higher levels within the design organisation. However, to both the Contracts Manager and Surveyor it was the internal political context within the department as a whole, and the significance of the NSS project in relation to that, that formed the backdrop against which these interpretations were drawn, and the underlying reasons for why this situation had arisen. These latter points will be returned to shortly. At this point an additional feature to note is that the situation was one in which the main contractor's more senior management were drawn into the detailed management of the project. As noted earlier the original Site Agent had left the project at an early stage, although no indication was given whether this was related or not to the circumstances described above. It was noted that the Contracts

Manager was visiting the site at that stage on an almost daily basis and, according to the account given by the representative of a subcontracting firm employed on the project, was acting as "the decision-maker on site", and had "tended to take over the job". The point to be made here is simply that the problems that occurred were associated with an 'escalation' in the level of interaction at which they were dealt with on both sides. The level at which decisions were reached on both sides was higher than that originally expected. Rather than the bulk of decisions being taken at site level and involving the Job Architect and Site Agent, the situation had developed into one in which the Project Manager/Contracts Manager level was the focus of decision-making activity on the project. It was also interesting to note the strategy adopted by the Contracts Manager in dealing with the extant situation. He reported that, as a reaction to the problems faced on site, he had taken recourse to 'by-passing' the levels within the design team which he felt were causing the problems: "The situation was getting so serious that in the end I had to go to the County Architect ... about a month ago". In his view, this had helped to ease the situation: "I haven't seen much of the Project Manager or senior architect since".

It should be stressed at this point that the contractor's perception that the client's team were to a significant degree operating with their 'hands tied' was not completely shared by members of that team. While it was agreed that the job, because it was 'important', had meant a greater level of involvement of senior staff, and both the Job Architect and Surveyor agreed that they frequently had to seek decisions and approval from above, this

was not specifically interpreted as a lack of autonomy or discretion, and was not given the same negative connotations as those given by the main contractor's staff. The Job Architect, for instance, stated that he was expected to report changes to the Project Manager, but had the authority to issue instructions and make decisions with the latter's "advice". "Approval" in a formal sense was not necessary for any changes that did not have cost implications. However, while pointing out that all information and instructions passed through him to the contractor, he did contrast the extant situation of a closer involvement by the Project Manager in dealings with the main contractor, with the expected situation in which he was the sole architect involved directly in monitoring the work. Moreover, the fact that there had been a substantial number of variations with financial implications did accord with the contractor's perception that the Job Architect was more commonly in the position of having to seek "approval" rather than "advice" from higher levels.

The position of the Clerk of Works was similarly set within the structural context of the Department. In particular, it was emphasised that the Clerk of Works did not operate like a "normal" clerk of works. That is, it was Departmental policy that the clerk's authority to issue any instructions to the main contractor (via site works orders) was proscribed. According to the Job Architect, "he can talk to and advise the Site Agent unofficially and does so ... but he can't instruct". While the contractor's staff recognised this restriction, the frustration they expressed at its impact on the current circumstances was made evident in the earlier comment. The implicit suggestion in that comment, that the

Clerk of Works was not in a position where he could 'assist' the contractor, compares interestingly when juxtaposed with a statement given by the senior architect within the department concerning the rationale generally for this formal limitation on the clerk of works' authority: "(they) become too much part of the contractor's team - we don't want to pay clerks of works to cover the foreman's mistakes". Taken together, these comments again point to the somewhat precarious position of clerks of works, and also to a degree of wariness on the department's part of main contractors' intentions. These issues will be returned to in more detail in the later analysis. The point to be made at this stage, however, is that while it was considered by members of the design team to be 'unusual' for there to be a greater degree of involvement at higher levels, it was not necessarily considered inappropriate, given the importance of the job and the nature of the design for it. What was considered by the contractor's staff to be an excessive and inappropriate degree of control exerted by the Project Manager in the running of the job was not considered by the design staff to be inconsistent with the formal mechanisms established for the supervision of jobs in general. In other words, there was a basic disagreement between the parties on the way in which a project such as the NSS should have been approached.

. The source of this disagreement in many ways reflected differential perceptions of the objectives set for the work. The discussion so far has concentrated rather more upon the perceived organisational and inter-organisational consequences of the job being an 'important' and 'prestigious' one, without considering the impact that this factor had upon the objectives - particularly in

relation to 'quality' and 'cost' - that were to be achieved. In describing the nature of the NSS project, the architectural staff - and the Project Manager in particular - emphasised that it was 'a quality job'. The Project Manager stressed the department's "reputation for good quality architecture" for which they had formerly won awards, and emphasised that "its our aim to make sure the quality is right" - this he stressed in describing specifically the landscaping work on the project. Focusing upon the same aspect of the job, however, the contractor's viewpoint differed radically: "too much money is being spent on landscaping which isn't necessary ... the root of the problem is that the architect is after an award; its a prestige job" (contractor's Surveyor). As was noted earlier, it was in the landscaping and finishes work on the project - the more 'aesthetic' parts of the job - that the main problems were perceived to have arisen. From the point of view of the Project Manager his job was to ensure that the quality standards he had set for the work (and was setting during the on-going design) were adhered to. From the point of view of the contractor's staff, however, these standards were too high given the budget for the project. The Contracts Manager, for instance, stressed the contradiction between the emphasis on a high quality job, and the financial constraints upon the project: "they greatly overspent in the early stages, because they didn't accept the quality that the low prices allowed for ... (the Project Manager) is trying to get a high quality job from a budget that doesn't allow for it ... its very difficult to convince them that if they want that quality, they've got to pay for it". The contractor's staff allied what they felt was too low a budget for the quality of work the designers were seeking to achieve, with the 'strict'

control exerted within the authority over expenditure on council projects to suggest that this helped to explain both the more centralised control exerted in the running of the job, as well as the delays and 'indecisions' that characterised the continuing design process.

It is interesting to note, however, how this perspective on the financial constraints on the project diverged with that given by members of the architectural team. The Project Manager, when asked, made no explicit reference to 'strict' budgetary control being exercised over the project, except to suggest that while he had the authority to 'allocate' funds across the project, any increases in the budget would require treasury approval. Instead, he suggested that given the quality standards set for the work, the onus was upon the contractor, having accepted the job at the contract price, to achieve these. A similar point was made by the department's senior architect. In referring explicitly to the "tight control" maintained over project expenditure in general, and to it being directly the responsibility of the Project Manager to monitor cost to ensure the project broke even or made a profit, he stated that a main reason for this was to put the responsibility for quality directly onto the main contractor. In other words, given the budget for the job and an agreed contract price, it was the contractor's job to make sure that the specification was met within these targets. The point to be made here, however, was that it was in the nature of the original specification - namely, the fact that the design was incomplete and involved later changes - that the scope for debate about the inconsistency of cost and quality objectives arose. To the architectural staff, given the

contractual position, budgetary constraints were not inconsistent with the standard of work they sought to achieve. To the main contractor they were.

While the accounts given differ sharply in their perception of the relationship between cost and quality objectives for the work on the NSS project, it was generally agreed that the aim of the department was to produce a high quality, low cost job for an important new client. If credence can be given to the main contractor's reading of the situation, then it suggests that the design team were in somewhat of a dilemma. If the 'political climate' within the authority was such that the longer-term survival of the department was indeed in doubt, and if success on the NSS project was a means to help ensure the continued existence of a full in-house professional design capability, then success rested upon reconciling a set of objectives that were not necessarily fully compatible. On the one hand, producing a 'high quality job' would satisfy the client making future orders more likely and generally serve to enhance the department's 'reputation'; on the other hand, the design team were required to exercise 'strict' control over expenditure on the project - this in a situation in which the budget set for the work may already have limited the options available.

If this was the case, then it is perhaps not difficult to see how this might have resulted in what was interpreted as a greater degree of control exerted over the continuing design process or 'interference' on the one hand, and uncertainty or 'indecision' on the other. As the individual with overall responsibility both

for the conceptualisation of the design, and for controlling project expenditure, the Project Manager may have been in a particularly acute position. The need to make sure that quality was kept high and cost kept low might well explain both the reported tendency to exert more direct influence over the work on site, as well as the reported tendency not to make firm and fast detailed design decisions. In other words, rather than the Project Manager 'not knowing what he wanted' it might rather more have been the case of 'not knowing how to achieve what he wanted, given the financial constraints'. The points made earlier concerning the structure of relationships within the team then suggest that the formal mechanisms existed whereby a greater degree of centralised control could be exerted over members of the client's supervising staff with the results described earlier. It has been mentioned several times that the project was not considered 'typical' in this respect. Yet the fact that all members of the client's project team (with the exception of external consultants) came under the direct and full jurisdiction of the architectural Project Manager in their involvement as members of the project team was a long-standing structural characteristic of the department as a whole. Similarly, the formal restrictions placed upon the Clerk of Works' authority to issue instructions. Consequently, there was no difference between the formal structure established for supervising work on the NSS project and how projects had been managed in the past. The implication is that it was the circumstances associated with the project which, in a sense, 'activated' these mechanisms to produce a high degree of centralised control within the client's team that was latent in the structure established within the department for the management of projects. An additional effect made implicit in

the earlier comments concerning the tendency for members of the team to 'cover themselves' was the greater degree of formality it generated in both their internal and external dealings.

The effect of these circumstances on the relationship between the client's team and the main contractor was made quite clear in the earlier comments. In particular the comments suggest a much more 'contractual' approach by both parties towards one another under the circumstances. The "us versus them attitude" that the Contracts Manager suggested informed the Project Manager's approach to them was countered by the main contractor uniting with their subcontractors "to fight the common foe". At the same time, however, there was explicit reference given to the belief that the 'combatants' were not evenly matched. The contractor's Surveyor for instance pointed to the effects that delays caused by rework and late information had upon tying down the insurance bond taken out to cover the work and upon the firm's resources, and suggested that the cash-flow implications for a firm the size of Steelframe were particularly acute. In addition he felt that a firm of that size was disadvantaged since it lacked the legal departmental backup that would be available to larger contractors. In his opinion, larger firms would also have not taken up the job in the first place, because the design was in "such broad detail". He felt that as a small, 'local' contractor, dependent upon the council for work, Steelframe did not have this option. In effect the suggestion was that it was the main contractor (or their subcontractors) which had borne the 'costs' associated with the attempts made to reconcile the set of conflicting objectives pursued on the project, and that their position - as a small

contractor dependent upon the council for work, and for whom this was a major project - made them relatively powerless to influence the eventual outcome in this respect. The Surveyor certainly reported that the job had not been profitable from the firm's point of view. The level of dissatisfaction expressed in earlier comments similarly points to this conclusion. It is perhaps not at all surprising to find that the contractor's staff would be dissatisfied at the lack of profitability on the job, and tend to attribute the problems they experienced to the design team. However, what was noticeable was the stark contrast they drew in these respects between their previous experience of working with the council and the department, and their experience on the NSS project. Moreover, the interpretation given above - of the builders bearing the brunt of the costs - appears to be consistent with the views of members of the design team noted earlier: that the onus was upon the main contractor to perform to the quality standards established. What is being suggested here is that the achievement of contradictory objectives on the NSS project was contingent upon diverting as much as possible of the 'pressure' they created elsewhere. The main contractor - as a small, dependent firm in contractually the less powerful position - was the recipient of the effects.

It is important to stress that much of the foregoing interpretation rests on the assumption of a basic conflict between the cost and quality objectives pursued on the project. Further, that this assumption is based most directly upon the accounts given by members of the main contractor's staff on the project, and drawn rather more inferentially from the accounts given by members of the design team. The importance of both sets of objectives was

stressed by members of the design team interviewed. However, any perceived contradiction between the two was not directly articulated. What were clearly articulated, however, were the respective stances taken on the pursuit of these objectives: from the designer's viewpoint, given the budget and contract price submitted by the contractor for the job, their job was to ensure that the job was built as they intended; from the contractor's viewpoint, the design intentions were incompatible with the budget available for the job. The problem was centred around the fact that the design for the work was initially incomplete: by the time work had reached the stage at which the 'quality' objective became paramount (in the finishes and landscaping), the financial constraints were looming large. It was in attributing the responsibility for achieving the performance levels in relation to the design specification for the work that the opinions of the two parties diverged.

(Finally and as a postscript to the accounts given of events on phase one of the NSS development, it should be reported that Steelframe tendered unsuccessfully for the second phase of the development, valued at £1 million. The contract was awarded to the firm with the lowest tender which was reported as being £2000 lower than the bid submitted by Steelframe. It was also reported that 7.5% of the value of the contract had been set aside as provisional sums, and that twelve drawings were available for tendering for the work.)

CASE STUDY: The Product Development Laboratory (PDL)

10.1. The Project, Client and Context

This project involved the construction of a new building which was to serve as a new products development laboratory for a large, private sector industrial client which specialised in the manufacture and retailing of pharmaceutical products. The building was to be three storeys high, and measure 70 x 30 metres in area, yielding a floor space of 5800 m² to be used for open-plan laboratory areas and office rooms. In addition, the work was to involve the construction of a small ancillary services building adjacent to it. The site for the PDL was to be on an area of previously unoccupied land within the perimeter of the company's main manufacturing and head office complex. It would be sited close to existing factory, warehouse and office buildings within the complex. The boundaries of the site itself were quite tightly drawn, reflecting the intention of preserving existing space and allowing for future possible new building developments in the immediate surrounding area.

The building was a 'one-off' project, intended to replace inadequate existing facilities available for new product research and development. It would eventually house staff from those departments engaged in work on three of the company's main product lines. Each of these departments had been allocated a separate floor of the new building. Its occupation, together with the installation of furniture and specialised equipment, would occur only after full completion and final certification of the works.

While it was to be designed specifically to the briefs supplied by the three users departments, it was also to be designed with a view to providing multipurpose laboratory facilities that could be switched to other users in the event of future changes in company requirements (i.e. new product lines).

The company, as client, was a large U.K.-based multinational firm, which had an annual turnover in the region of £⁵⁰⁰ million. Its size, and a corresponding high continual level of investment in building work made it a sizeable and experienced private sector client. Its involvement in building ranged from the construction of new plant, warehousing, office and retail facilities, to the maintenance and renovation of its existing extensive industrial and retail stock. The PDL project itself was quite a sizeable one-off new capital investment, being initially budgeted at £4 million to be spent over an 18 month construction period. It was one of the largest current new building project being undertaken by the client in the U.K., and represented a substantial capital investment in new building work, albeit a somewhat smaller fraction of the company's total level of annual capital expenditure.

10.2. The Client's Representatives

For the design and overall management of work on the PDL project, the company made use of its own directly-employed, architectural and (structural) engineering staff. They were based within the company's Design Division, which was headed overall by a Chief Architect who reported directly to the Board of the company. The Division was relatively small, employing approximately 30 architects, structural engineers, technicians and clerical staff.

Its staff were mainly involved in the design and supervision of contracts for the new building, maintenance and refurbishment of the company's retail outlets. Larger-scale 'industrial' projects such as the PDL, had formerly been designed and managed by external private consultants employed by the firm. This was the first project of its type and size to be designed and managed in-house. It therefore represented something of a departure from the more 'routine' side of the Division's work, particularly given the intended specialised function of the building as a laboratory. It was also a sizeable venture, in relation to the volume of turnover on building work that was managed by the Division. Indeed, it was the largest single project currently being undertaken in-house, and involved a substantial level of commitment of the Division's resources. This was reflected in the fact that, during the course of the PDL project, up to about half of the department's staff were directly involved in the project - the remainder of the staff being employed on the company's continuing retail projects. According to senior architectural staff the project was therefore of some importance to the Division: it was the first of its kind that the client had decided to undertake in-house, and success on the project would increase the likelihood of the client again using in-house facilities for the design and management of future major industrial projects.

In addition to its own design staff, the company contracted two firms of private consultants : one to provide mechanical and electrical design services (the M & E); the other to provide surveying services (the PQS). The former was to be involved in the detailed design for, and supervision of, the services installation for the project; the latter was to be involved in the initial costings for

the project, the drawing-up of contractual documents, the tendering process and the financial monitoring and evaluation of work on site. Both firms of consultants operated from local branches of larger, national practices. Their experience of working for the company as a client was extensive, and senior representatives of both firms reported that the client was a significant and continual source of work locally. The M & E consultancy, for instance, had been involved in the design and construction of the company's original central complex some 50 years previously. The PQS had established its own section to deal with major builders and clients with whom they had a continuing working relationship over time. This included the current client company.

10.3. The Main Contractor

The main contract for the construction of the PDL works was let, under a management form of contract (see below), to Hardcore Contractors Ltd - a private company, registered as a 'general building contractor'. The company was a wholly-owned subsidiary of Hardcore Holdings Ltd, which in turn was owned by a large parent company involved in international transportation. The holding company owned a number of separate firms involved in construction and related activities (e.g. civil engineering, construction plant, (speculative) housing). Hardcore Contractors in turn owned four trading and non-trading subsidiaries involved in specialist activities at home and general construction management abroad. The company was a large contractor which operated nationally, and whose head office was located some 120 miles from the PDL site. It employed some 2500 staff in total, and in the accounting year that fell between the start and finish

dates of the PDL project its fixed assets stood at around £600,000 and its net current assets at £5.5 million. Its annual turnover approximated £150 million, which compared with a figure of £100 million for the previous year. In both years its pretax profit, expressed as a proportion of turnover, stood at around 3%.

As a company, Hardcore Contractors Ltd specialised in under-taking work under 'fee' and 'management-only' forms of building contract. The essential differences between these and the other, more traditional, forms of contracting arrangement, lie in the nature of the role performed by the main contractor during both design and construction stages, and in the form and manner of payment (see, for instance, *Coxter 1972*). Specifically, the main contractor is paid a fee which is a negotiated percentage of the value of the main contract. For this, the contractor is involved more intensively in the design and planning processes than would be expected under traditional tendering arrangements. During construction, the role of the main contractor consists essentially of co-ordinating and controlling the work, the majority of which is subcontracted. In the case of management-only contracts, of which the PDL was an example, this extends to the whole of the work - which is completely subcontracted. In other words, the function performed by the main contractor is purely managerial, for which the contractor is paid a fee in much the same way as consultants are paid a fee for providing professional design services. Consequently, the main contractor in effect becomes a member of the client's team on the project, and is not involved directly in the performance of the actual work on site.

The manner of operation of this form of arrangement will be returned to and discussed in fuller detail below. The point here is that the company had had considerable years' experience of operating

exclusively these distinctive forms of contract, although the full switch away from a more traditional approach within the group as a whole and the development, in particular, of a management-only form had occurred only within the previous decade. The development of the firm's specialism in these areas had been linked with the association of the company with one major private sector retailing client which had at one time accounted for nearly the entire turnover of the company, and which currently still accounted for some 20% of the company's turnover. Apart from the work commissioned by this one particular client, the range of projects undertaken by Hardcore tended to reflect the type of work where the cost associated with the management fee was liable to be offset against the perceived advantages of the system in allowing for 'fast-track' construction (eg Carter 1972) and the co-ordination of work on site. That is, the projects tended to be large-scale, 'one-off' and complex projects.

Work on the PDL project was of this type, although it was not so large as many of the projects the firm had undertaken, and represented only a relatively small proportion of the company's annual turnover at the time. However, it was also the first contract that the company had been awarded by this particular client, and consequently provided the opportunity for the firm to add another large scale client to its list. Senior managers within the firm reported that the project was therefore important in enabling the company to secure follow-up retail and industrial projects commissioned by the client company in the future.

The design process for the PDL project had involved the preparation of outline design proposals and preliminary costings on the basis of the briefs supplied by the three user departments, their briefs having been agreed by the company. The outline proposal was prepared by architects and engineering staff in the Design Division in conjunction with the PQS, who had by that stage been appointed by the company. These proposals were approved by the Board of the company approximately 15 months before work was due to start on site. Following their approval, which set the value of the contract at £4 million (plus inflation) to be built over a 78 week construction period, the in-house design staff, together with the M & E consultant and PQS were involved in the establishment of a detailed design for the works and the preparation of documentation for tendering (bill of quantities, specification, working drawings) respectively. It should be noted that, at about this stage, the decision had been made by the company to opt for the appointment of a management contractor, rather than to use a 'traditional' contracting arrangement. This point is returned to in more detail below.

The structure established for the management of the PDL project followed the normal practice of the Design Division in their management of projects. At the same time, senior staff reported that the scale and nature of the work implied a somewhat greater level of staff involvement and commitment of resources, than characterised work on other more standard (and usually retail) projects that were undertaken. The Division as a whole comprised two main sections - Architecture and (structural) Engineering - which contained groups of staff, around half of whom for each department specialised in the company's

industrial work, of which the PDL was the single largest current source. The management of the PDL, like other projects, was delegated to a senior architect who was appointed as Project Manager, and who reported directly to the senior executive of the Division who was the Chief Architect. The Project Manager appointed from his own team a Job Architect, who was involved in the broad and detailed design for the project, and subsequently in the detailed supervision of work on site. Both individuals were to supervise work on the project through its design and construction stage. Working for them was a team of junior architects and technicians from their own group within the department, who prepared details and working drawings, etc. The role of the Project Manager extended to the co-ordination of aspects of the design and "liaison" with the consultants hired for the project.

Staff from the engineering section within the Division worked collaterally with the architectural team, providing detailed designs for the basic structure of the building on the basis of the agreed design proposal. Their main representative on the project team was a senior engineer, who in effect acted as an internal "consultant", and was involved in the PDL project through both its design and construction stages. The Engineers' own staff consisted of design engineers and technicians who had been seconded from within his own design group to the project.

10.5. Characteristics of the Design

As noted earlier, the PDL project, and consequently the design of the building, constituted very much a 'one-off' undertaking. The project was therefore custom-designed, rather than involving the use

of a standard overall design. The actual structure of the building itself was to consist of a reinforced concrete frame, built in situ, externally clad with precast panels. Internally, there were to be two main stairwells and a central lift shaft. Offices were to be constructed of internal blockwork with plaster and paint finishes, and the laboratory areas were to be left open-plan. Externally, the work involved the construction of a small ancillary service building, the laying of access roads, a small car park and general landscaping of the immediate surrounding area. The types of materials and the methods of building to be used for the broad structure of the building were to be relatively familiar.

On the other hand, the major design feature of the PDL project, was the intensity and nature of the services work that was involved. The function of the building as a laboratory meant that work would involve special features (such as glass drainage), and the installation of laboratory-specific fixtures and fittings (e.g. fume cupboards, lab. benches). There was also a corresponding increase in the volume of mechanical and electrical services work to be installed, which was coupled with the already extensive mechanical, electrical, heating and ventilation systems associated with the operation of a fully air-conditioned building of this type and scale. These services were to be contained mainly within a suspended ceiling. Consequently, the project was complex, in terms of the design for the M & E works, their integration with the main structure of the building, and the more unusual characteristics of some of the materials and methods of building that were to be employed. An emphasis, therefore was put upon the M & E design, and its co-ordination with the structural design for the works. It was noted that, as well as being employed to design the M & E works, the consultant was paid an additional fee

for providing extensive and detailed mechanical and electrical services co-ordination drawings for the project. This was regarded, by both the consultant and senior architectural staff, as an important element of the design process for the PDL project, and one which ultimately facilitated the integration of mechanical and electrical engineering services design, particularly given the relatively short programme for the construction of the works as a whole. The design for the PDL project was by no means complete by the time that work was due to start on site. Consequently, there would be a degree of design 'overlap' into the construction stage, particularly in respect of the services work, where the detailed design work would depend upon the details and drawings supplied by nominated subcontractors that had been appointed. While 12 months had been allowed for the establishment of a full and detailed design following the approval of the proposal, in the event a significant change in direction occurred towards the latter stages of this period, which had important implications for the design process and the subsequent construction of the job. Specifically, after the main contractor had been appointed (see below), and with about only one month to go in the lead up into construction, the Board cut the budget allocated for the project by £250,000 (or about 6% of its total estimated cost). The reasons for this decision were not made clear by the respondents. However, its implications were made clear, and corroborated by all parties. Namely, the cut in the budget forced a reappraisal of certain aspects of the design of the building, and put pressure upon the architectural and engineering staff to produce the design on time as planned. According to senior staff from all parties, there was a 'change in the direction of the design' at that point to accommodate the reduction in the budgeted funds available. The main contractor, it was agreed,

had not been appointed sufficiently early enough during the design process for the full 'benefits' of their input into the design to be realised. However, with the cut in the budget, their involvement in the design process became more intensive. A specific example of this, which also suggests the significance of the change, was the redesign of the drainage system for the building. Specifically, the original plan had been to install a 'standard' system that was external to the building. The revised plan allowed for the construction of a central 'undercroft' within the foundations of the building to house the drainage system together with some of the services cabling and ductwork.

The point to be emphasised here is that any 'overlap' that would have occurred between the design and construction stages of the project was extended by changes in the design that were effected at this stage by the decision to reduce the budget. Pressure was put upon the design team to prepare plans for construction, and, as will be seen, information that was needed was often late. Additionally, the changes that occurred increased the likelihood of variations to the design occurring during construction, a factor likely to compound the number of variations and alterations that were already expected to occur given the intensity and complexity of the services work involved. More generally, the change in the context of an already 'tight' programme for construction would make the co-ordination of work on site no less difficult.

10.6. Tendering and the Main Contract

The tendering procedure for the award of the main contract for the PDL project was somewhat distinct from the procedures described

in the other four cases in the sample. According to the PQS and senior staff within the client's Design Division, the original intention had been to let the main contract under standard (JCT) terms and conditions. The decision to employ a management contractor instead had occurred only after approval of the outline design proposals and project costings had been given by the company's Board. The reason was given as the 'tightness' of the programme for construction, which had been set at 18 months: it was felt that employing a management contractor would be the only way in which the established programme dates could realistically be met. According to the same informants, it had been the company Board which had initiated this change. The tendering procedure had then involved the negotiation, by the PQS, of the contract with Hardcore Contractors, on the basis of the initial estimate of the work prepared by the PQS and a finalised design proposal. This process occurred some 4 - 5 months prior to the actual start date on site, and Hardcore were formally appointed about four months before construction was due to start.

The estimated and negotiated cost of the project at this stage was established at £4.5 million, which included a 5.5% management fee for the main contractor. (The cut in the budget described above made the value of the contract £4 million.) The period for construction of work remained at 78 weeks (November to April). The contract was let under Hardcore's own form of contract, and included these terms and conditions, together with the bill of quantities, specification and working drawings (both those already issued, and those to be issued during construction). The work was to be evaluated, and the issue of interim certificates and payment to subcontractors to be made, on a monthly basis, with a 3% retention

withheld. Provisional sums, totalling about 3% of the value of the works had been set aside in the bill for contingencies and additional work. The damages for delay (for which the main contractor was still liable under a management contract) were set at £5000 per week. The period allowed for final evaluation, certificate and payment to the contractor was six months after completion on site. The defects liability period for the whole works was 12 months.

Because the main contract was let under a management form of contract, the work that was to be done on site was undertaken entirely by subcontracting firms. Further, each subcontractor was nominated : for each trade (e.g. joinery, cladding, etc.), a 'package' of contractual documents, comprising a bill of quantities, specification, outline drawings, planned start and finish dates, a method statement and terms and conditions of contract were to be drawn up by the PQS and main contractor. For each 'package', six firms would be selected to tender a price, and a recommendation would be made to the client's representatives on the basis of the prices submitted and details of interviews held by the main contractor with prospective bidders. Subject to their approval, the subcontractor would be appointed. For the PDL project, approximately 40 separate subcontractors were to be appointed to perform 40 'packages' of work. The form of contract under which they were employed was the standard (JCT, 'green' form) set of general terms and conditions of subcontract, which had been substantially amended to fit in with the requirements for a management-run job. The point to be made here is that the 'package' system of subcontracting on a management contract project meant the establishment of a large number of separate sets of documents for each nominated subcontractor, and an emphasis upon the individual subcontractor's distinctive role under a management

form of contract. This point will be elaborated and explored in more detail below. In relation to the earlier discussion of the cut in the budget and the design changes that were made, it meant that the establishment of a full set of documents for the trades involved had to take account of these changes. Consequently, the already large quantity of paperwork associated with the establishment of a detailed 'package' for each trade, was added to by amendments and alterations to the design and specification in some instances (e.g. the specification for the groundworks following on from the change from an external to internal drainage system, as quoted above).

The programme of work established by the main contractor during the tendering process and the negotiation of the main contract, allowed for the completion of the work within the contractually-specified period of 78 weeks. The broad plan for the works involved the 'building up' of the main structure, after which the internal structural work and finishing work would take place simultaneously within the building. The services work would carry through from the earliest stages of the building of the main structure, through to full completion. The relatively short period allowed for construction would place a particular emphasis upon the co-ordination and sequencing of the main services and finishing trades (e.g. plumbing, electrics, plastering, decoration) during the latter half of construction. Individual subcontractors' programmes of work (including expected start and finish dates, duration and sequencing of their different activities) were specified in the documentation sent out to firms that were tendering for the job. The 'tightness' of the programme would mean that there would be little room for manoeuvre in the scheduling and phasing in of subcontractors' work on site.

A fuller discussion of these aspects related to the sequencing of phasing of work within the overall programme will be returned to later.

10.7. The Main Contractor's Site Team

A full-time resident site team were appointed to the PDL project to manage the work on behalf of the main, managing contractor. The firm's senior representative supervising the construction of the work was a Site Agent, who reported directly to a Contracts Manager who visited the site on a weekly basis (on average), and who was also currently supervising work on four other company projects in the region. The site team consisted of production, technical and administrative staff as illustrated below (Figure 10.1). Of that team, it was noted that one of the General Foremen was in fact "between jobs", and left the project at an early stage, having been transferred to another company site locally. The Site Engineer's involvement in the project similarly ended, with the completion of the main structural work about half-way through the construction period. All the staff involved on the production/engineering side of the job had been transferred in from other company sites and, with these two exceptions, were to be employed for the full duration of the project. It was noted that their secondment to the project had followed on from internal interviews conducted by head office Contracts Department staff following the award of the main contract to Hardcore. The firm also employed directly a gang of (8) general labourers who were transferred from other company sites to undertake "general service" work on site, and to provide the subcontractors with 'attendances'.

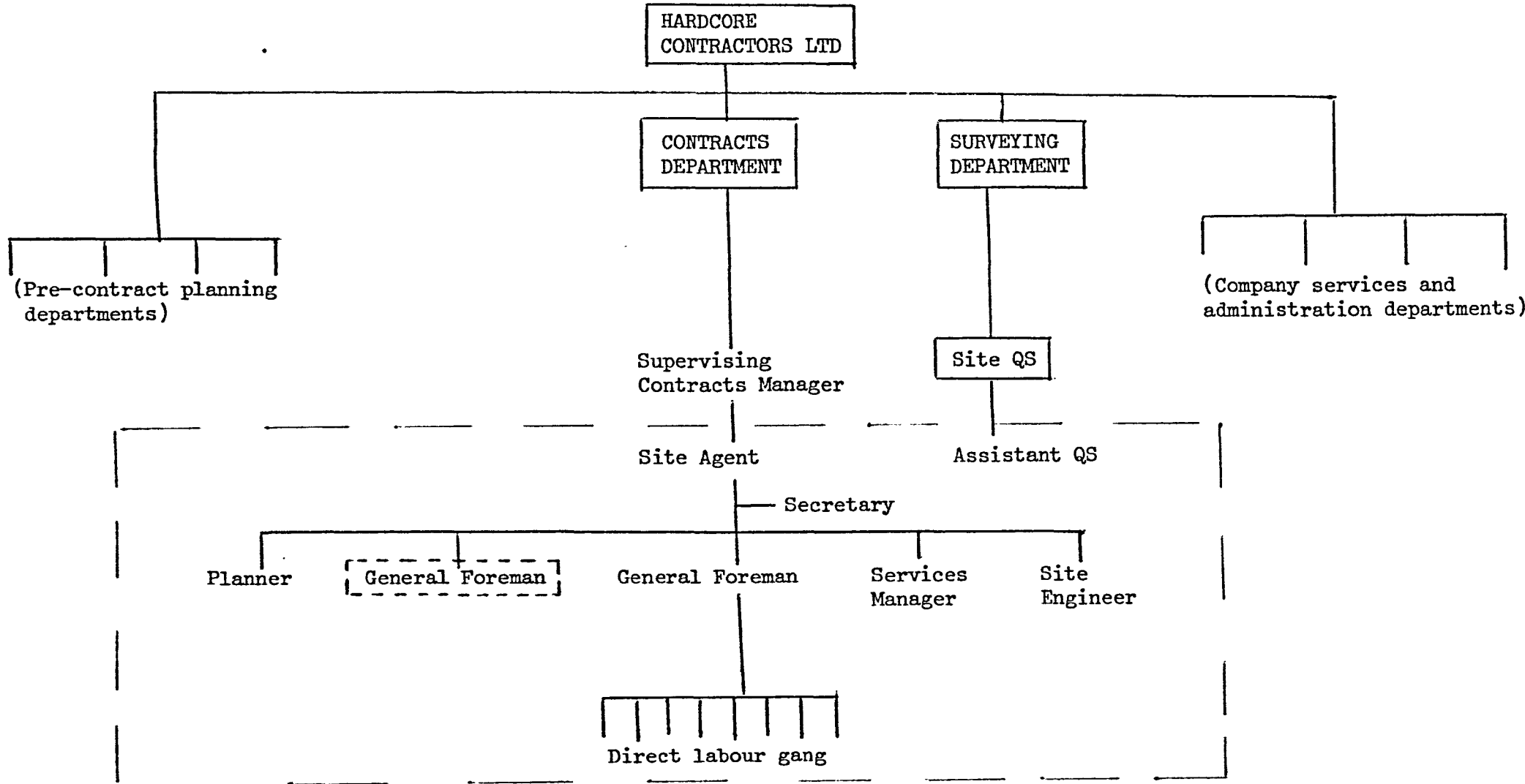

Figure 10.1 Hardcore Contractors Ltd: Site management team and relationship to head office

The appointment of a Services Manager to the site team reflected the intensity of services work involved on the PDL project. His job was to co-ordinate and supervise the plans for, and installation of, the mechanical and electrical engineering services work. Consequently, there was a degree of role specialisation within the team according to the type of work that was involved on site : the services work, an important feature of the project, was separated out and designated the responsibility of a specific member of staff.

The firm also employed two surveyors (QSs) on site. The assistant QS was employed full-time and for the duration of the contract, having been transferred in from another company site. The senior surveyor, however, was involved only part-time on the project, albeit for its full duration. He had been seconded from the contractor's head office, rather than being transferred from another site. According to the supervising Contracts Manager, the nature of the job as a management contract meant that the volume of work for the QS on site became much more extensive, and the role a much more important one. This was given the closer working relationship that was expected to develop with the client's PQS, and the volume of work associated with managing 40 detailed and separate subcontract 'packages'. He described the relationship between the senior QS and the Site Agent on the construction side as one of "balanced authority", and himself as forming the 'cross-over point' between the two sides of the team. However, he also noted that his own involvement was much more at a 'contractual' level in conjunction with the QS, and that the secondment of the senior surveyor from the head office made for a slight difference in "status" between the 'construction' and 'contractual' sides of the team.

All of the staff mentioned had worked for the company for some time. However, it was only the Contracts Manager and Services Manager who had had any prior experience of management contracting as such. The rest of the staff had worked on the company's 'management fee' contracts in the past, and had also had experience of working in more 'traditional' settings. However, they had not been involved in a project before where the main contractor had not performed any of the work directly. Their reaction to working under this form of arrangement was given in terms of the differences in the roles that they performed. The General Foreman, for instance, contrasted his role as planner and 'co-ordinator' of subcontractors' work with the more direct involvement in its supervision that would occur on a "normal" project. The Site Agent pointed to a similar distinction in his own role on the project. It was interesting to note that the Services Manager and Site Engineer - on the technical side - likened their own roles to those performed by client's supervisory staff on traditional contracts. The Services Manager described his own role as, to some extent, being very similar to that performed by an M & E Clerk of Works. The Site Engineer similarly compared his role closely with that performed by a resident engineer's inspector on a 'normal' project.

As a brief diversion, it is interesting to note the reactions of the staff to this type of arrangement. Generally, the staff on the production/technical side found working upon management contracts less 'satisfying'. A loss of identification with the work, and lack of control over it, were cited by the Site Agent, General Foreman and Site Engineer as reasons for this. The Site Agent additionally pointed to the greater volume of paperwork on the job, and to the greater amount of time spent in the office, rather than out on site.

The General Foreman described his role on a management contract as "not very good for satisfaction". He felt "less involved" because the work was being done entirely by other firms. He described his job as "continually going to and fro" between the subcontract foreman and Clerk of Works, acting as a 'mediator', but without having the power to be able to give instructions or take decisions without having to go back to the office for approval. He described this latter constraint as putting him in an often "embarrassing situation". An additional and related factor was identified by both the Site Agent and Contracts Manager - namely, the reduced flexibility the site staff generally had in being able to 'sort out problems' on site, since the contractor had very little working capital. The Contracts Manager coupled this lack of flexibility in being able to take action to expedite the work with the loss of direct control over the work to conclude "... on balance, it's marginally less satisfying".

Given these views, it is interesting to compare them with those expressed by other staff. The views of the client's representatives are described below. To preempt that discussion, on balance, they appeared to find this form of arrangement more 'satisfying' than traditional forms. Interestingly, the contractors own surveyors appeared in favour : the assistant QS described it as "more satisfying" and related this to the closer contact he had with the subcontractors' own QSs and the PQS, and to the greater "team" relationship that existed with the PQS. The senior QS echoed this latter view, and pointed to the more 'neutral' role of the contractor's QS in contrast to the 'adversary' relationship that existed under traditional forms. He described his job on a management contract in this respect as "... no less satisfying - certainly different".

10.8. The Client's Supervision

The work on site was supervised, on behalf of the client, by the Project Manager and Job Architect who had been involved in its design. They were based off-site, in the company's design office, and visited the site at relatively frequent and regular intervals. The Job Architect was the member of the team who was most directly involved in the supervision of the work and visited the site some two or three times a week on average. His involvement on the project was full-time both on site and in the design office. The Project Manager, who was not involved in the project full-time, visited the site, on average, fortnightly. A similar pattern of involvement in supervision to that of the Project Manager was undertaken by the in-house structural engineer representative during the first half of the project. The individual involved was the same one who had been involved in overseeing its design.

To supervise the construction of the project on a day-to-day basis, a full-time resident Clerk of Works had been appointed, having been transferred from another of the client company's building sites. The Clerk of Works was formally employed within the company's 'Works Division'. He had been seconded to the project team by management within that division "on request" by the Project Manager. His work on the PDL project then came under the direct jurisdiction of the Job Architect.

In addition to the in-house staff, individual representatives of each of the two consulting firms (the M & E and PQS) were involved in supervising the job on a part-time basis, involving visits to the site on a (fortnightly) basis. These representatives had been those involved in the pre-site design and planning stages, and their

supervision of the work was in each case backed up by staff working at their local offices. For the M & E consultant, for instance, it was reported that about four office staff (two each from the firm's electrical and mechanical services section) were involved full-time on the project throughout its course. The visiting consultant was an electrical services design engineer who was an associate of the practice. There was no Clerk of Works appointed to monitor the M & E works. Instead, as noted earlier, the contractor's Services Manager in effect performed this role. The structure of supervision of the client's representatives is illustrated below (Figure 10.2).

None of the staff supervising the work on behalf of the client had formerly had any experience of working under a management form of contract. Their experience had only been of the more 'traditional' (i.e. JCT) type of arrangement. Consequently there was some lack of familiarity with the particular role requirements involved - a point that will be returned to in more detail below. Also, their reactions to working under this form of arrangement will be returned to in due course. However, in reference to the earlier discussion concerning the reaction of the main contractor's staff, it is interesting to note that the Clerk of Works - the client's 'construction' representative - had similar reservations about the method as those expressed by the contractor's production and engineering staff. Indeed, he expressed a preference for the more traditional arrangement, based on the observation that the organisation of work on the PDL project made the job more 'fragmented', and made it more difficult for the team on site "to gel". These comments differ somewhat from the earlier comments reported and the reasons underlying them will be returned to later. However, the interesting feature to notice here is the consistency of the reaction towards involvement under a

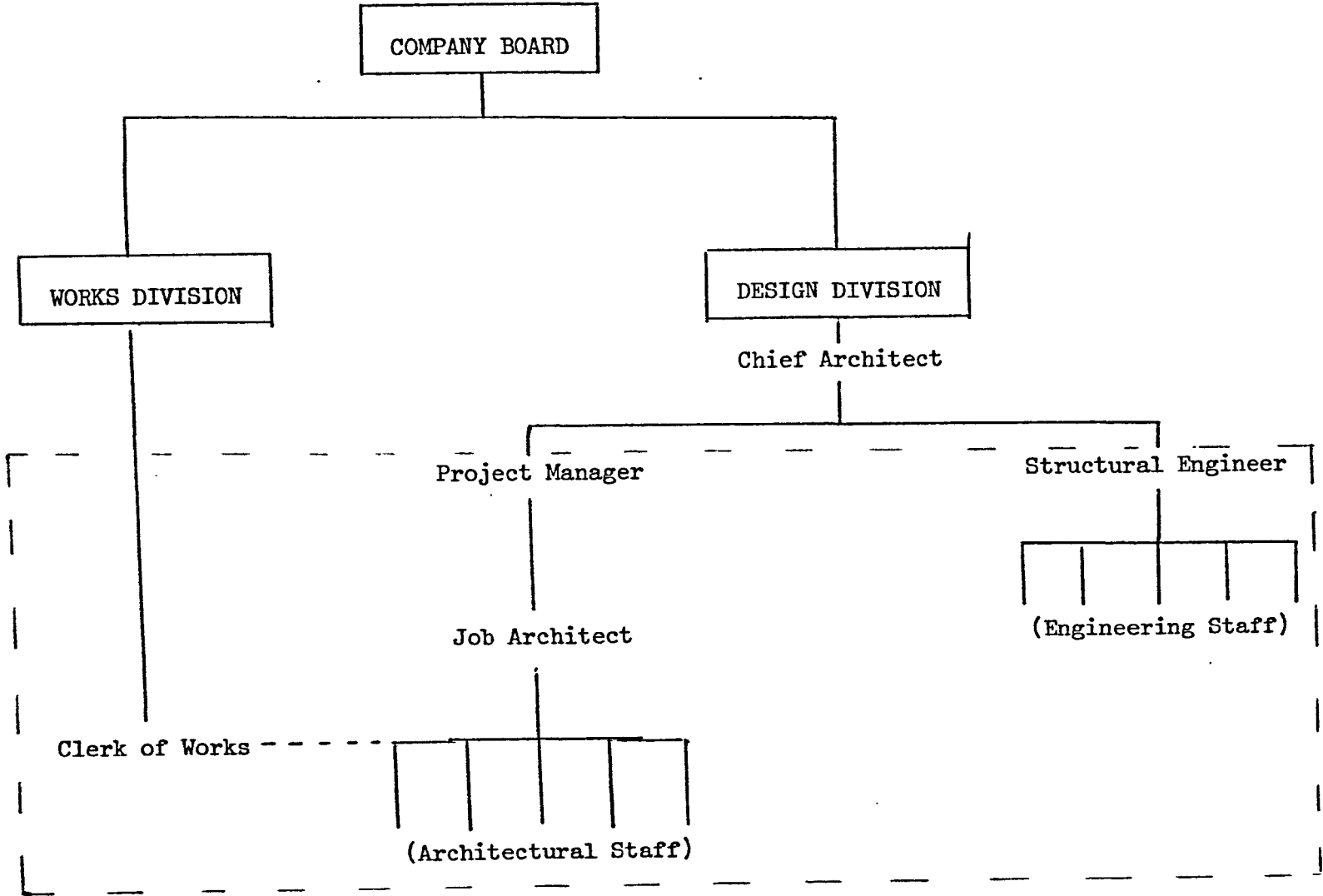

Figure 10.2 The client's 'project management team' on the PDL project and relationship to 'head office'

management form of contract : across the organisations involved, it was production staff who were less inclined to favour the form, whereas specialist, professional staff (i.e. architects, engineers and surveyors) found it a preferable way of working.

10.9. The Organisation and Management of Work on Site

In presenting this data for this case, full details of the process of management involved on the PDL project (as with earlier case studies) will not be reported here, due to the similarity of many of the basic functions of management involved on site between the case studies. Instead, the more salient characteristics of the work involved on the PDL contract will be highlighted in relation to the organisation and management on site by the main contractor.

Because the job was run as a management contract, the main contractor undertook no direct resourcing of the work. Instead all labour, plant and materials were supplied by subcontractors. Subcontracts had been let - by the time work started on site - for the work needed in the early stages of construction (i.e. the excavation and groundwater; these were combined with the main structural work and let as a 'general building' package to one firm). Orders had also been placed with separate firms to undertake the main mechanical and electrical engineering services work. With these major exceptions, most of the remaining subcontract packages (e.g. the plastering, tiling, cladding and roofing) were let during the course of construction. Consequently an important element in the resourcing of work on site was the forward planning for and placing of orders with subcontracting firms as work progressed. The 'lead times' for

this process was derived from the overall contract programme. Detailed design information needed to be obtained at an early enough stage to allow for the drawing up of a detailed package of work, and for the tendering and detailed planning stages involved before work could start on site. As noted earlier the 'package' system involved the contractor obtaining formal approval for the subcontractors appointed from the client's representatives.

The tendering arrangements involved in subletting the 'packages' to specific firms were undertaken entirely at site level. Because each subcontractor was 'nominated', the decision on which firms to appoint required client approval, but no approval from higher levels within the main contracting organisation. Similarly, the administration of subcontracts once they were let (including payments) were handled on site - involving the PQS and contractor's QS in measuring and evaluating subcontractors' work and the Project Manager authorising payment, by certificating the work done, direct from the client to the subcontractors involved. Unlike the RAW project (and the other case studies in the sample), the fact that the main contractor on the PDL project undertook none of the work directly and employed no 'domestic' subcontractors, meant that the main contractor's head office played no direct part in resourcing the work or in providing 'back up' administration in this respect.

The actual process of placing new subcontracts involved the Site Agent and Planner in conducting formal interviews on site with representatives from the six companies invited to tender for each of the packages. These interviews involved an explanation, by the main contractor's staff, of the characteristics of the work and, in particular, of the terms and conditions of work associated with it being run as a management contract. The Site Agent reported that a

strong emphasis was put in the interview upon an explanation of the responsibilities of the subcontractor on a management contract, with a view to ensuring that the firms that were tendering were aware of the peculiar characteristics of this type of arrangement. In addition, the interview was used to assess the firm's capacity to do the work, the people who would be directly involved in its management - at head office and site level, the time that the firm would need for planning and tendering, and the overall financial standing of the company and its other commitments. Consequently, the process involved obtaining quite a good deal of information concerning the capacity and experience of prospective subcontractors. This information was passed on to the contractor's QS on site who, together with the PQS, managed the tendering arrangements for each individual package. It was generally agreed that the cut in the budget for the contract as a whole had led to decisions on appointments then being made almost entirely on the basis of the lowest submitted tender price for each package. This point will be returned to more fully below. The point to be emphasised here is that the role of the main contractor's staff on site in resourcing the work was entirely indirect - consisting primarily of making sure that subcontractors were placed in sufficient time to meet the contractually-agreed starting dates on site. The levels and types of resources then supplied by subcontractors were at their own discretion, subject to the constraints embodied in the client's specification of the work and the programme of work established by the main contractor. According to those involved in the process of subcontracting, the separation of the entire project into a series of 'packages' meant that a good deal of work was associated with defining or specifying in detail each separate package, and in delineating the work - in

other words deciding what to include in which package. Since the main contractor performed none of the work directly, there was little scope for allowing items of work to be 'picked up' by the main contractor by default.

Given the appointment of subcontractors to perform the work, the main contractor's staff were involved in programming the work to be done on a medium- and short-term basis, managing the flow of design information between the design team and subcontractors, setting out lines and levels on site for subcontractors to build to, and in supervising the work produced on site and monitoring performance in relation to the overall contract programme. Medium-term programmes covering ten-week periods of the work were drawn up by the contractor's staff from the overall contract programme, from which more detailed weekly programmes of work were established - both for the job as a whole, and for the individual subcontractors employed on site. These latter programmes of work described in more detail the duration and sequencing of particular activities within each subcontracted trade on site based upon the overall start and finish dates for the work given in individual subcontractors' programmes included in the documentation for tendering. Individual subcontractors' contract programmes therefore established the parameters for their work based on the overall contract programme: that is, the start and finish dates, the broad sequencing of work, and major interdependencies with other trades; the more detailed planning of work was undertaken on a weekly and daily basis on site within these parameters. Progress on the job was monitored on a daily basis, and information and details of progress on site were fed back into the weekly planning process, and in the form of weekly reports to the client's staff and the contractor's own head office. The weekly reports on progress for

individual subcontractors formed the basis upon which their performance on the project was monitored.

The management form of contract had an important bearing upon the processes related to the design and specification of the work to be produced on site. Specifically, the role of the main contractor in this situation was primarily to act as co-ordinator and centre of communication in the flow of design information between the design team and subcontractors. This involved arranging the flow of design information and correspondence to suit the programmes of work on site, and recording and checking information and drawings as they were received from both design team and subcontractors. In setting out the work, the main contractor was to provide only broad lines and levels, from which subcontractors then set out their own work in more detail. The methods of building to be used, and the quality of the materials supplied by subcontractors were based upon the individual method statements and specifications included in subcontract documentation, and were to be accepted or approved by the client's representatives, as were the standards of work actually produced on site. In these respects too, the main contractor's role was essentially one of co-ordination - between subcontractors' detailed plans for producing the work on site, and the requirements established by the design team.

Within the main contractor's site team, the Site Agent drew up the medium-term programmes of work, and - with the General Foreman - drew up subcontract programmes for tender. However, the more detailed shorter-term scheduling of the work on a weekly and daily basis, and its monitoring in these respects, was undertaken by the General Foreman, who dealt directly with the subcontractors' representatives on site in establishing programmes of work. The

Site Agent's role in this process involved 'approving' these schedules of work (before they were issued to the subcontractors and copied to the client's staff and contractor's head office) and dealing directly with subcontractors' representatives at site and office level, in the event of any problems encountered in planning out the work on site. The General Foreman was also the member of staff most closely involved in directly monitoring progress on a day-to-day basis, and in providing detailed information on progress to the Site Agent who drew up the weekly progress reports which were distributed to the client's staff and copied to the contractor's head office.

It was generally agreed (by both the main contractor's staff and subcontractors' representatives who were interviewed) that the General Foreman's role in these activities was central, and that his involvement in planning and co-ordinating the work was much greater than had been anticipated. It was reported that he in effect was performing the role of the main contractor's planning engineer on site. The Planner seconded to the team, it was generally agreed, was much less directly involved in the actual planning process and in arranging work with subcontractors on site, and concentrated more directly upon performing the administrative work involved (i.e. recording the information and instructions received, issuing programmes of work, etc.). In effect, the role that he performed was that of administrator of the quite considerable volume of paper work between the client, contractor and subcontractors on the project.

While the programming of the work on site was undertaken by the General Foreman for all aspects of the work, the activities associated with the detailed design and specification of the works

(i.e. checking drawings, methods and materials, setting out the work and supervising it) involved the General Foreman and Site Engineer in respect of the main building trades, and the Services Manager in respect of the engineering services work. They dealt directly with the respective subcontractors' representatives on site in sorting out the details in the work involved and monitoring its construction. Their involvement in these aspects of the work was co-ordinated by the Site Agent who conducted weekly in-house 'co-ordination meetings' held within all the 'construction' staff to plan out the weekly work in advance, in addition to generally supervising the work on a day-to-day basis. According to those involved in the process of supervising the subcontractors work on site, any problems in the drawings, setting out or performance of each aspect of the work, or in the integration of the structural or services components, were 'internally' referred up to the Site Agent who then became more closely involved in dealings with subcontractors' site representatives (or office staff) and the client's supervisors (the Clerk of Works and Job Architect). It was interesting to note that the Services Manager described a close degree of involvement with the M & E consultant and subcontractors on site in respect of these activities, and noted that most problems that occurred in the M & E work were resolved through this channel, rather than involving the Site Agent directly. He and the Site Agent reported that it tended only to be M & E problems with financial implications, or ones affecting the programme of work that generated any wider involvement from members of the contractor's site team.

A series of formal meetings were established to deal with the co-ordination of subcontracted work, programmes of activity, subcontractor resource levels and design matters. For the services work, the Services Manager held weekly co-ordination meetings with

the representatives of the mechanical and electrical services subcontractors. According to staff involved on the structural side, meetings were held, on average, weekly with individual subcontractors on site, although the formal procedure specified a fortnightly meeting. In addition to these more formal meetings, it was noted that numerous ad hoc meetings were held - either to discuss the work with individual subcontractors, or with representatives from two or three subcontractors to discuss the co-ordination of their work. The involvement of the contractor's staff in these meetings varied, as did the level of involvement on the part of the subcontractor. Depending upon the substantial issue at hand and its 'contractual' importance, the meetings were held by the General Foreman, Services Manager and/or Site Agent on behalf of the main contractor, and involved the subcontractors' representatives on site and/or their visiting Contracts Managers.

Apart from the more formal systems (described earlier) to monitor performance, the direct involvement of the contractor's head office staff was limited to the visits to the site made by the supervising Contracts Manager (and to the part-time residence of the senior Surveyor). Members of the contractor's site team were in general agreement that the site operated with a high level of autonomy from the head office, and that the Contracts Manager formed the main direct channel for contact between the site and the head office. This reflected in the main the characteristics of a management form of contract: that is, the emphasis upon performing a 'management-only' role on site meant a greater concentration of senior and experienced staff on site, which in turn meant that the need for closer direct supervision and involvement by head office functional managers (e.g. planners, engineers) was obviated. While

direct access was available to services provided by such head office departments, in practice it was noted that they were rarely involved directly on the project during its construction stage. In addition, as noted earlier, the employment of 'nominated' subcontractors for the entire works meant that there was no role performed by head office staff in resourcing work on site during construction. Agreements and negotiations concerning details of the work were undertaken between the client and the subcontractors, with the main contractor performing a 'co-ordination' role at site level.

However, one feature of the site - head office relationship did have a bearing upon the discretion afforded to site management: specifically the absence of any working capital that was noted earlier. This point will be returned to more fully in the ensuing discussion. The point to be made here is that the site needed authorisation from higher levels within the firm for direct expenditure of any funds other than for 'petty cash' items. The monthly payment to the main contractor consisted only of management overheads ('preliminaries') and a fixed percentage profit. Unlike the other case studies in the sample, the site did not operate on a monthly profit and loss basis. As will be described later in more detail, this placed the main contractor in a contractually 'neutral' position vis-a-vis the client. However it also served to reduce the scope of management on site in expediting work.

The involvement of the client's staff in the management of work on the PDL project consisted of approving the programmes prepared by the main contractor, issuing drawings and instructions on the basis of requests submitted by the subcontractors via the main contractor, checking proposed methods and materials to be used, and supervising generally the setting out and construction of work on site. It

was the resident Clerk of Works who was most closely involved in supervising the main building work on site on a day-to-day basis and in sorting out enquiries concerning the working drawings and details of the methods used by subcontractors on site (as noted above, a comparable role was performed on the M & E side by the contractor's Services Manager). The Job Architect visited the site on a regular basis - usually in response to queries being raised on site concerning the detailed design or the methods and materials being used by subcontractors (the M & E consultant performed a comparable role in relation to the M & E works). In relation to the issuing of instructions to the contractor (for transmission to the subcontractor performing the work), the Clerk of Works was authorised to issue site orders that had no cost implications which were to be confirmed by a subsequent architect's instruction. Instructions related to the issue of working drawings, the clarification of design details, and acceptance of subcontractors' materials and methods were drawn up by the Job Architect. In the case of instructions related to additional work or variations to the existing work, it was reported that these required costing by the PQS and contractor's QS and approval from the supervising Project Manager before they could be issued by the Job Architect. A similar procedure was established for issuing instructions in relation to the M & E work : while the consultant clarified details, approved subcontractors' shop drawings, methods and materials, variation orders or additional work instructions required an architect's instruction approved by the Project Manager.

The main formal forum for monitoring progress on site was a regular three-weekly contract meeting held on site. It was attended by the Project Manager, Job Architect and Clerk of Works (and

also the Structural Engineer in the first half of the construction period), together with the PQS and M & E consultant on behalf of the client, and the contractor's visiting Contracts Manager, Site Agent, QS, Planner and Services Manager on behalf of the main contractor (it was also noted that a representative of the company's Estates Department attended the meeting on behalf of the user departments). At the meeting, the contractor presented a report on progress, set against the overall programme for completion, and a breakdown of each subcontract package in relation to the programme of work, design and construction details, and resource levels employed. In addition, the agenda included a review of the tendering procedure for outstanding subcontracts that had not been placed, and a list of design information required (by subcontractors) from the design team. The details of the meeting were minuted and distributed to all those involved, as well as to more senior (head office) staff from all the organisations involved.

10.10 Performance on the PDL Project

As noted in Chapter 5 above, the PDL site was first visited six months into the construction period, at which point work was in progress in erecting the main frame for the building, installing the external drainage system and in the early work associated with the installation of the engineering services. The bulk of the work was being undertaken on site by the two subcontractors undertaking the main frame construction and the excavation and drainage work (the latter as part of the 'general builder' package). They employed workforces on site of approximately 40 and 15 respectively at the time of the first visit. At that stage, the contract was running an estimated 2½ weeks behind the programme (not including time lost - a week - due to bad weather). It was reported by those interviewed at that stage that this represented an improvement in the situation as it had stood some 3 - 4 months earlier when delays in the construction of the main frame had occurred that had threatened to put the date back for final completion some 4 - 5 weeks. Retrospective accounts were given of the circumstances which surrounded this delay. They will be returned to in more detail in the later discussion, since they offer some important insights into the manner in which relationships amongst the organisations involved developed over the course of the project's construction cycle. However, it is sufficient to note at this point that the main contractor was in the position at that stage of reducing the effects that had been caused by delays in the earlier stages, in order to allow for full completion on time.

The series of visits to the site continued through its course

up to and including the final week of the contract programme (as described in Chapter 5). Progress on the project stayed at around two weeks behind the programme until a period surrounding the midway point of the contract, when a series of delays to the internal blockwork construction, plastering and screeding work (ie in the main internal structural and finishing trades) knocked back progress to approximately a month behind the programme for completion. At that stage the bulk of the work being undertaken was in the finishing and services trades for which a total subcontract workforce of around 130 was being employed. The close interdependency of these trades on site, coupled with the already 'tight' programme for completion meant quite a concentration of effort by the main contractor at that stage on replanning work and drawing up revised medium-term (finishing) programmes to meet the target completion date, and to contain the 'knock on' effects of delays in the finishing work. (At that stage it was noted that most of the subcontract 'packages' had been let. This was with the exception of a few (about six) associated with specialist fixtures and fittings that were to be installed - and these were in the main in the latter stages of tendering. The volume of outstanding detailed design information needed was also recorded as being very low at that point - not only for the main structural work, but also for the M & E services).

By the later stages at which the PDL project was visited, the total subcontract workforce employed on site had risen to a figure of between 140 - 150 (in the period 2 - 3 months prior to completion). The effects of the delays that had occurred earlier in the finishing trades had been contained, and the project had

been brought back on course for completion on time. This is how it stood at the time of the final visit to the site with the programme having been achieved - allowing for the effects of bad weather. The only issue outstanding at that stage concerning the programme of work, was the contraction in the time available for commissioning the M & E services prior to the handover of the building to the client. This point, together with an assessment of the factors that were perceived to have been associated with the earlier delays to the work, will be returned to in more detail in the later discussion. In terms of the cost of the job, it was reported (by the architectural staff and PQS) that the budget had been met, when allowance was made for price fluctuations, the amount paid for coordinated M & E services drawings, and certain items not included in the original bill (eg the cost of 'protecting' certain items of work on site) .

At the end of the construction period, members of the client's and main contractor's teams who were interviewed expressed their satisfaction at the outcomes that had been achieved in respect of the time, cost and quality objectives set for the project, given both the early reduction in the budget available and the 'tight' programme of work. The architectural staff and consultants all expressed the view that the project would not have finished on time and within budget under a more 'traditional' (ie JCT) contractual arrangement. They related this mainly to the expectation that a main contractor operating on this project under a JCT form of contract would have submitted claims for delays stemming from late design information in the earlier stages - a point that will be expanded upon below.

A good deal of attention was given to the way in which the characteristics of a management form of contract had influenced the process of construction. In terms of the contractor's input into the design process, it was not felt that the full benefits of a management contracting approach had been achieved in this instance. This was viewed as being due to the relatively late stage at which it had been decided to switch to this form, and the fact that this had meant that the main contractor was not involved in the preliminary design stages when variations and 'snags' that had occurred in the design might have been picked up. This view was shared by members of the main contractor's staff (Contracts Manager, Site Agent) who felt that management contracting needed to be run "wholeheartedly" (Site Agent) in order to achieve the "full benefits" (for the client). They did not feel that this had happened in this case. The Contracts Manager for instance, reported the difficulty of assimilating all the design information available when the main contractor became involved only at a relatively late stage in the pre-site planning process. The Site Agent additionally noted that for it to be a fully "effective" system, it required earlier involvement plus a "freeze" on the design: "otherwise design problems keep cropping up and causing delays". As noted earlier, this was not a project which had been characterised by a clear separation of the design and construction phases. Nevertheless, it was felt that the approach had had some 'pay offs' in this respect. The Project Manager and Job Architect both referred to the savings generated by the change to the design for the external drainage system as an example of the benefits of including the contractor in the design process. All in all the Project Manager expressed his "delight" at the performance levels

achieved, and stated that he would like his company to adopt the system for future work. The Job Architect appeared slightly less enthusiastic, and set the benefits of the method against the costs associated with the greater level of supervision involved.

As noted earlier the role performed by the main contractor under a management form appeared to have implications for the level of job satisfaction expressed by members of the main contractor's staff when they compared it to working under a more 'traditional' form of contractual arrangement. The same can be said for members of the client's team who were interviewed - although here the lack of direct involvement in the detailed management of work on site was cited as the distinct advantage. The Project Manager, for instance, contrasted the greater time available for undertaking design work in the office on a management contract, with the tendency to get "bogged down" on site and more extensively involved in contract administration rather than design work under a JCT form of contract. This view was echoed by the Job Architect who referred to the tendency not to get "drawn into" direct dealings with subcontractors on site as a positive advantage under a management form of contract. A similar point was made by the M & E consultant, who referred to the main contractor acting as a "buffer" between the design team and subcontractors. He suggested that an advantage was that dealings with subcontractors were then conducted "behind the scenes" between the main contractor and subcontractors - rather than directly involving the design team. What was made clear by these comments was the implication that the form of arrangement had upon 'distancing' members of the design team from detailed operational circumstances on site and from embroilment in direct negotiations

and dealings with the subcontractors involved. At the same time reference was also made to the impact it had upon 'closing the gap' between the design team and main contractor as the central member of the 'building team', and also to the greater degree of 'involvement' of design team members in the project as a whole. The first point was made by all those interviewed - who contrasted the 'teamwork' on this project with the more 'adversarial' relationship between designer and builder found in other situations. The second point was made specifically by the two consultants employed on the project. The PQS, describing his experience on the management contract as, broadly speaking, more 'satisfying', referred to the greater degree of involvement in the project through more frequent visits to the site, and a closer working relationship with the contractor's QS as important features from his own point of view. This he set in the context of a relationship with a main contracting firm that was "on your side". The M & E engineer described the set-up as "refreshing" and attributed this to the more open discussion and greater appreciation of others' problems that he felt had occurred. He also felt that it allowed him to contribute to discussion on wider aspects of the work on site than those concerned specifically with the details of his own specialism.

. It should be stressed that these comments were made retrospectively, at a stage when the objectives set for the work on the project were on the point of being successfully achieved. The comments were also informed directly by experience on that particular contract, since none of those cited had had any prior experience of management contracting. Indeed many of those

interviewed commented upon the impact that the process of adjusting to the unfamiliar circumstances on a management contract had had in affecting the development of relationships during the course of the PDL project. The Project Manager, for instance, stated that he had found it "very difficult to change the habit of years working on JCT jobs" - where the designer and contractor are adversaries. Others involved pointed directly to the impact that this adjustment had had upon working relationships at an early stage. The Clerk of Works for instance, commented that: "Early on ... a lot of friction was caused and working relationships weren't very good ... I think it was partly because the (architects and structural engineer) weren't used to management (contracting) and felt they should be pushing the job more". At that early stage, attention had indeed been directed towards this factor - particularly by members of the contractor's team. The Contracts Manager had reported that: "... the architects don't really understand the implications of the management team concept ... we have good relationships with (the consultants), but our relationship with the designers hasn't developed so well". The Site Agent had also commented: "there's far less communication than there should be ... no-one tells each other what's going on". The implications were held to have been a lack of "teamwork" and "communication" between the parties at that stage - problems that were widely reported by members of the contractor's team at the time, but which were also corroborated by members of the client's team both then and in subsequent interviews. The Clerk of Works, for instance, referred to the tendency to circumvent the 'correct' channels: "(the architect) would come on site and say 'that's not right' and go straight to (the main contractor) for answers ... (the main

contractor) got caught in the crossfire ... they didn't use me to the full extent they should have". He commented also upon the tendency for the architectural staff to issue instructions direct, rather than rely upon the Clerk of Works and the issue of site orders by him. These issues will be returned to shortly since they have an important bearing upon understanding the process of management on the PDL project. The point to be emphasised here is that experience on the PDL project was characterised to some extent as a learning process associated with an understanding of the parties' respective roles under that type of arrangement. The implication of this factor, together with a consideration of the impact of other circumstances surrounding the PDL project on the development of relationships amongst the parties will be returned to next.

10.11 The PDL Project: A Case Analysis

What is particularly interesting about the PDL project was the fact that the objectives for the work were seen to have been achieved successfully despite the impact that the pressure they created was viewed as having upon the management of the project, and the earlier difficulties associated with an adjustment to an unfamiliar type of arrangement. Reference has already been made to the 'tight' programme, the cut in budget for the work, and the design 'overlap' into the construction period. These were viewed as critical features which affected the orientation of those involved in the project throughout its course. It is the inter-relationships amongst these factors, coupled with the distinctive setting of a management contract which forms the backdrop against

which developments on the PDL project need to be viewed.

The first series of points that need to be made concern the continuing design process and the characteristics of the design that was produced for the works. Firstly, it was generally agreed that the early stages of the project were marked by difficulties in the production and transmission of detailed design information. The Job Architect described the "pressure" that had been put upon the structural engineers to produce drawings in time given the cut in budget and consequent change in design direction. The main contractor's staff had at that stage referred to the difficulties experienced in obtaining design information from the structural engineer (and architect) sufficiently early enough to allow for subcontractors' programme dates to be met. The early, critical delay to the construction of the main frame, for instance, was attributed by them to delays in the receipt of detailed information from the structural engineer. However, attention was also directed more broadly at the level of detail in the drawings and specification - particularly in relation to the architectural design - and the corresponding tendency for there to have arisen a good many alterations and variations to the detailed design as the work on site progressed. The PQS, for instance, noted that: "For the purposes of measurement the drawings were adequate ... (but) I don't think they were full enough (for construction purposes)". He, together with the M & E consultant, Clerk of Works and main contractor's staff, attributed this in large part to the early pressure on the design team. The implications were reported as being the difficulties in picking up 'snags' at a sufficiently early stage, and in responding to subcontractors' requests for

detailed and definitive information. Midway through the construction programme, the Site Agent estimated that there had been some 800 instructions issued - many of them pertaining to alterations in the details of the design for the work. The Site Agent also identified a further characteristic of the design that he felt had exacerbated the problems. Specifically, in describing the (architectural) design as "vague", he linked this directly to a distinctive "style" that he felt was being adopted by the designers in their approach towards this particular project. He pointed out that the job was not 'normal' in that respect and that the distinctiveness of the design had implications for the approach adopted by subcontractors towards the job. He suggested that, for instance: "(subcontractors) see it as a normal job and won't bother to look through seven or eight drawings just to get one detail". The point here is that the distinctive character of the design, and its continuation during construction, coupled with ambiguities concerning which party was responsible for checking drawings and details tended to lead to a situation in which 'snags' were either not initially picked up, or were picked up and corrected in a somewhat ad hoc manner.

The point to be emphasised at this stage is that the problems associated with the lack of a complete and definitive design for the work coexisted with the period of 'adjustment' to an unfamiliar form of contractual arrangement. This was reflected in the comments made at earlier stages concerning the types of problems that arose and the reaction of those involved to them. The Site Agent, for instance, describing the lack of "communication" referred to the tendency for his own staff to have to "correct" drawings issued by the design team if there were errors "out of necessity". The

General Foreman referred to his having to "fend off" subcontractors while relevant details were being negotiated and drawings prepared. The assistant QS described the tendency for the design team not to accept the contractor's "recommendations". A tendency to bypass the 'appropriate channels' was also noted in later comments given by the Site Agent referring to direct design dealings that had occurred between the architectural designers and subcontractors. His point was that there were occasions on which the main contractor was not informed of detailed alterations to subcontracted work until the work was actually produced. He referred specifically in this instance to the design of the laboratory benches that were to be installed, although his view was that this had occurred in a wider range of instances - a view that was corroborated by the PQS. The general point to be stressed at this stage is that the extant pattern of working relationships on the PDL project - particularly in its early stages, but also quite a considerable way into the construction period - contrasted with what was expected should have occurred, given the 'management team concept'. The approach actually adopted was viewed as particularly counter-productive in circumstances in which the design was both initially incomplete and somewhat distinctive.

The second series of points concern the impact that tight financial control by the client had in such circumstances. Members of both the client's and contractor's teams generally agreed that control over expenditure on the project had been tight. The problems experienced midway through the programme in the blockwork, plastering and screeding work were cited as being in part an indirect consequence of this factor: specifically that the reduced

budget had forced the acceptance of the lowest subcontract bids which in the event had proved 'calculated risks' given the quality of work actually produced by these subcontractors (this observation was made by members of both teams). The inherent contradictions in the objectives being pursued in this respect were summed up by the Clerk of Works, who suggested that: "the problem is in trying to get 'value for money' when the money you're paying (is less than) what you'd need to get the value you expect". More directly, reference was made to the impact that financial constraints had upon the continuing design process. The point has already been made that the cut in budget effected a change in 'design direction'. The point was also made that in this context, modifications to the design were continually looked at with a view to minimising costs and achieving savings - to such an extent that it involved efforts to make savings on 'packages' already agreed with subcontractors (this point was specifically made by the main contractor's Planner). The importance of this factor was highlighted by members of both teams. The Site Agent for instance, described how the concern for reducing costs had "dominated" events on the PDL project. The Clerk of Works commented that: "everything with cost implications has to be looked at ... (the client) is very firm on this". The implications were held to be that this situation had "reduced the effectiveness" of the 'management team' (Planner) and instilled a degree of rigidity in relationships amongst the main participants. This suggestion is drawn from comments given - particularly by members of the main contractor's staff - which contrasted an ostensibly 'flexible' approach to managing work under a management form of contract, with the more formal patterns of interaction and a more

'contractual' approach experienced under current circumstances. In relation to direct dealings with subcontractors, it was felt that the emphasis upon reducing costs, coupled with problems in the design, and in a situation in which the main contractor acted in effect only as 'go-between' between design team and subcontractors, combined to place the main contractor in an invidious position. The consequences from the subcontractors' point of view will be explored later.

Up till now only passing reference has been made to the implications of these factors in a situation in which the work was subcontracted in its entirety. In describing their implications, a good deal of stress was laid upon their effect upon relationships between the main contractor and the subcontractors concerned. The contractor's Contracts Manager, in describing the main contractor's position felt that they were "in the middle - wearing two hats". On the one hand, their experience of directly undertaking work on site suggested a degree of sympathy with the problems faced by subcontractors on this project; on the other hand, their commitment to the client as part of the 'management team' was their main allegiance. The Site Agent in referring specifically to the early problems in the main frame construction expressed the view that their role in upholding the client's interests conflicted with their predisposition to support valid subcontractor claims. In other words, the members of the main contractor's staff felt they were 'caught in the middle' - realising the problems faced by subcontractors, but obliged to cut down claims to a minimum. The Site Agent and other members of the contractor's team felt that the consequence was that relationships with subcontractors on the job

were "sourred" - in that problems in obtaining drawings and information and recompense for delays tended to adversely affect the subcontractors' reactions to any subsequent problems that arose on site. The same was felt to be true in the impact that the distinctive 'style' adopted for the design had upon direct design dealings between the architects and subcontractors: the Site Agent, for example, pointed out that: "... they (ie subcontractors) haven't had to provide samples before (ie in previous jobs for the same client) ... but on this job (the architect) has insisted on samples and often rejected them (without giving an explanation why)" His interpretation was that this then tended to feedback into the subcontractors' relationships with the main contractor, with the consequence that any 'give and take' in the relationship was exchanged for a more uncompromising approach.

Later in this discussion experience on one particular 'package' will be described in some detail to illustrate some of the points raised above. At this stage, the point to be emphasised is that the main contractor's staff viewed the situation as one in which they were to some extent 'compromised' in their position vis-a-vis the design team on the one hand, and the subcontractors on the other. Interestingly this view was not necessarily shared by members of the design team. The Project Manager for instance, referred to their initial lack of "trust" of the main contractor that stemmed from their own perceptions that the main contractor was "defending" the subcontractors too much. Referring to early delays on site and problems in design dealings, he commented that he had felt the main contractor, as part of the professional team, should have been "clobbering" the subcontractors more. Although he added that these

early perceptions changed as the project developed, there was a suggestion that this view continued to be held to some extent further into the project: the Clerk of Works, for instance, reported towards the end of the construction period, that he felt that the main contractor's primary aim - of meeting the programme completion date - had tended to produce a "bias" towards subcontractors and a tendency not to "push" them too hard. He commented: "I'm not suggesting (the main contractor) has skimped, but it has caused problems (in quality control)". What this commentary suggests is the tendency for the approaches of the two main parties to the contract as having been informed by somewhat divergent expectations of the role that was to be performed in the management and control of subcontracted work: to the main contractor an 'allegiance' to the client's team was countered to some extent by an appreciation of builders' problems and the felt need to avoid 'aggravation' with subcontractors which might jeopardise the plan for completion; to the design team, a role as the client's main 'building' representative meant a full identification with the objectives pursued by the professional team, and an emphasis upon ensuring that subcontractors fully achieved those objectives. The inference is also that the pressures associated with the performance of time, cost and quality objectives on the PDL project were accommodated in a way which reflected the different priorities attached by the parties to the pursuit of these objectives. Before looking further at the manner in which this occurred to produce a situation at the end of the job in which it was felt that the objectives had to all intents and purposes been successfully achieved, it is perhaps useful to give in greater detail a picture of developments on one particular package. This with a view both

to illustrate many of the points made above, and to provide further insight into the manner in which the objectives on the PDL project were achieved.

The specific example is of the subcontract order placed for the manufacture, supply and fixing of precast concrete panels for the external structure of the building. The firm supplying the units was a local firm which specialised in the off-site manufacture and on-site assembly of concrete structural components, and which had undertaken work for the PDL client in the past. Since the actual construction of the units was undertaken off-site in the firm's local factory, the period of involvement on site itself was fairly brief (when compared to that of other subcontractors building in situ); and the emphasis then was upon co-ordinating the work with other trades on site and maintaining progress on the units' assembly (rather than simultaneously monitoring the quality of work produced as in the case of in situ work). The units were custom-built to the architectural specification, and all design dealings in this respect were largely to have been undertaken before the panels were assembled on site.

In the lead up to the construction period (during the month prior to the subcontractor's start date on site) representatives of the main contractor and subcontractor were involved in a series of meetings and site/factory visits aimed at planning out in detail the programme and sequence of assembly of the panels on site. These meetings and visits involved variously the Site Agent and General Foreman on behalf of the main contractor and the Construction Director, Factory Manager and supervising Contracts Manager on

behalf of the subcontractor. At issue was the scheduling of work on site to meet the programme dates in a situation in which circumstances had changed since the original programme had been agreed. Firstly, the subcontractor had experienced a week's delay in their production of units which had put back the programme of work on site by a week. Consequently the subcontractor was vulnerable to a claim for delay. However, in the meantime the main contractor's programme had also run behind, such that they were now vulnerable to a delay claim from the subcontractor. While the delay by the subcontractor was made known to the main contractor, the main contractor's delay was not made known to the subcontractor. The Site Agent reported that the initial delay by the subcontractor in the event suited the main contractor's revised programme of works, and that they had an interest in now having the panel erection occur at the later date. The net effect was that a revised start date was accepted by both parties and no action was at that stage taken on claims. Secondly, the original plan that allowed for a straight and continuous schedule of panel assembly on site had been confounded by related work which was being currently undertaken on the main structure. The problem was that the physical interdependence of the two tasks on site meant that the sequence of panel assembly needed to be adjusted, but could only be adjusted in a way which led to disruption - either in the production schedule for the units (which would involve costs associated with storage and double-handling charges), or in the programme of work on site (which would involve costs associated with maintaining idle resources on site). In both cases, the subcontractor would be able to claim for the associated costs. In the event, the solution eventually reached was for the subcontractor to begin work on site a few days later than originally

planned, for which they would be able to obtain recompense for disruptions to their production schedule.

What is of interest about these issues is the way in which they were tactically resolved. Speaking for the main contractor, the Site Agent pointed out that the early delay by the subcontractor proved convenient - both in fitting in with the main contractor's delayed programme, and in putting the onus onto the subcontractor to adjust their own schedule to get past the problem with the interdependent work on site. Provided the subcontractor was unaware of the main contractor's own delay, then their ability to press for claims stemming from the second problem was countered by their vulnerability to claims associated with the first problem. The Site Agent also point out that the second problem occurred due to it being 'overlooked' in the original plan of work. He added that if the subcontractor had not overlooked the details of the plan, they would have noted that the original plans were incorrectly marked (the wrong elevations were given) and that this would allow them leverage to pursue a claim. Given these factors he described the process of reaching agreement with the subcontractor's representatives concerning a revised programme of work as having involved an element of "diplomacy".

. Having reached agreement over the schedule of work on site, the next problem arose in installing the panels on site. Specifically the main frame columns had been built too high to allow for the correct positioning of the panels. The problem was attributed by the Site Agent to a confusion in the design dealings between design team and subcontractor: that an early variation had been incorporated

in the drawings for the main frame construction which had implications for the panel fixing, but which had not been allowed for in the architectural drawings from which the subcontractor was working. The result was that this 'snag' had not been picked up until the columns had been built and the panels were ready for fixing. The subcontractor was initially unaware that this was the cause of the problem and began cutting the panels to fit. According to the subcontractor's Construction Director, they approached the architect suggesting it would be less costly and time-consuming to shorten the columns. However this course of action was not taken until it was discovered that the problem had arisen due to a design variation, at which point the subcontractor stopped work on site, the architect issued an instruction to cut the columns and the main contractor expedited this work. The subcontractor then submitted a claim for delay due to this work holding them up.

Further problems occurred subsequent to the fixing of the panels when it was found that insufficient 'tolerance' had been allowed and the windows would not fit. According to the Clerk of Works the design had allowed for very little cumulative tolerance in the construction of the frame, the fixing of panels and windows. However, the amount of tolerance available had been misinterpreted (by the main contractor) as being much greater. The subcontractor's Construction Director felt that the tolerances available were impossible to achieve, but also felt that the subcontractor should have picked this up at an early stage. The work was in the end expedited by the main contractor by drilling into the panels to fit the windows. According to the Site Agent the subcontractor at that stage had accepted some of the responsibility for the problem,

while the architect had not. The subcontractor was subsequently to be issued with a claim from the window fixers for the delay caused to their work.

At the end it was reported that the work was finished on time (to the subcontract programme), although the 'tolerance' problem did have knock-on effects. At the contract meeting at which the account was closed, it was recorded that the subcontractors claim (for the columns problem) had been withdrawn and that the subcontractor had accepted payment for the earlier off-site costs. At that meeting the contractor's Contracts Manager and QS and the PQS reported that the outcome had been favourable financially. The Project Manager, Job Architect and client representative did question the payment to the subcontractor - however the contractor's staff and consultants all argued against this and for the account to be closed. The M & E consultant for instance referred to re-opening the account at that stage as "dangerous". The contractor's QS commented that the financial outcome "could have been worse".

When interviewed subsequent to this, the subcontractor's Construction Director expressed his (to put it mildly) dissatisfaction at the way the job had gone from the firm's point of view: "We left the job with a very sour taste in our mouth, and no respect left for (any members of the design team or main contractor's staff)." He attributed this to: "the double-dealing that went on ... When the job was first delayed (which he felt was the main contractor's fault) ... we could have thrown the book at them but we didn't ... After that, every time we put a foot wrong the architect threw the book at us without mercy ... (The main contractor) didn't do anything

to back us up". He contrasted his experience of this contract on which there had been "no team spirit" with both a "normal" job in which "it's the contractor's responsibility to 'look after' the subcontractors", and other management contracts on which he had not experienced such problems. He expressed the view that the architectural staff had given the firm a "runaround" and had been unwilling to accept their ideas or recommendations; he felt the main contractor's staff had responded to the (design) problems by not representing the subcontractor's interests and "hiding away from problems".

While developments on this particular package are not necessarily representative of events on other packages during the course of the project, they do both supply illustrations of many of the problems that were generally perceived to have characterised progress on the PDL (specifically in relation to the co-ordination of work and the design for the work) as well as direct attention towards how these problems were resolved in the context of the distinctive role being performed by the main contractor. What are of particular interest are the observations that (a) subcontractor's omissions or errors gave the main contractor a negotiating ploy that allowed them to minimise the claims submitted against the client; and (b) when this failed the main contractor became involved in directly expediting the work. The first point echoes the earlier observation that members of the client's team felt that they were not involved directly in the 'wheeling and dealing' that went on. Taking the panel package as an example, it suggests that this 'wheeling and dealing' was conducted in a manner which served to protect both the main contractor's interests (in getting the work performed on time)

and the interests of the design team (who were vulnerable to claims stemming from late or undetailed design information). The corollary is that this occurred at the expense of the subcontractor's interests - a point which links in with earlier comments made by both the main contractor's staff and the (panel) subcontractor concerning the impact that the situation had upon relationships between the two parties. In other words the situation was one in which the main contractor appeared to 'protect' the design team to some extent. The second point suggests a similar interpretation: that shortfalls that emerged in the performance of work on site due to the circumstances described earlier were reacted to by the main contractor employing a strategy of directly expediting the work - in contrast to the expectation that they would not be involved in performing any of the work directly, and that it was the subcontractor's responsibility under a management form of contract to do so.

These interpretations are given extra credence by reports given of other events on the PDL project. The early delay to the construction of the main frame for instance had given rise to a claim submitted by the subcontractor concerned for delays stemming from late information. However, this had been withdrawn following a 'deal' that was made between the subcontractor on the one hand and the main contractor and PQS on the other. It was reported (by both the main contractor's staff and PQS) that a payment was made to the subcontractor to 'accelerate' their work to bring it back on programme (the payment was funded 50/50 by the main contractor and PQS and did not involve the design team). According to the PQS, it was felt that the subcontractor "had a case", and on a 'normal' job the main contractor would have pushed for a claim due to late

information. Here, to avoid a 'claim situation', expediting the work was the only alternative to avoid serious effects on the programme. The collaboration on this issue between the main contractor and PQS was felt by both parties to reflect a concern with avoiding disruption to the programme of work associated with the design problems experienced. The contractor's QS, commenting on the part played by the PQS, noted: "they (the PQS) don't have any (financial) incentive to do this ... (But) they do have a strong relationship with one or two of the subcontractors ... judging by (the money that's been paid to expedite the work) they're interested in seeing that the job runs smoothly". Other examples of the main contractor directly expediting the work were found (eg the later appointment of a full-time plasterer at no cost to the client to do remedial work) which will not be expanded upon here. More generally, the point is that such steps were taken with a view to achieving the time and cost objectives set for the work in a situation in which those objectives were generally perceived to be difficult to achieve, and their achievement further threatened by problems experienced in the production and transmission of design information from the design team.

The theme implicit in the foregoing discussion is that the pressure to achieve time and cost objectives led to the main contractor being involved in a variety of tactics aimed at limiting the impact of design-related problems (ie directly expediting the work; negotiating down subcontractor's claims; colluding with the PQS to recompense subcontractor's valid claims). A tactic with similar intentions, but notable in the extent to which it reflected the success of the main contractor's strategy occurred right at

the very end of the construction period. At issue was the time available for 'snagging' the building, and, in particular, commissioning the electrical services work. At the final contract meeting before overall completion was due, the M & E consultant and Clerk of Works argued that there was insufficient time left for these activities and that the completion date could not be met. The main contractor's staff argued that the completion date had to be, and would be met - the Contracts Manager instructing the Services Manager to directly supervise the subcontractor's work and become more directly involved in its commissioning. The various arguments were minuted and the question, in effect, left open.

In a subsequent interview, the Contracts Manager reported that the electrical subcontractor might possibly be submitting a claim for delay, and that the intention had been to avoid this possibility at such a late stage by "protecting" the subcontractor against the professional team's pressure (to expedite the commissioning work). Interestingly he noted the architectural staff's lack of support for the consultant's position on this issue and suggested that this was informed by the need to avoid any potential delays in the final completion of the work. The consultant's (and Clerk of Works') view was that they were being "squeezed" at the end and - not untypically according to the consultant - not being allowed sufficient time to perform these activities. The M & E consultant echoed the Contracts Manager's comments by suggesting that on this issue the main contractor and design team had 'collaborated' in order not to jeopardise the completion date.

This final comment was generalised by the consultant

to the way in which relationships had developed in the latter half of the construction period. In particular he referred to what he felt was the critical factor that had influenced developments on the PDL project. Specifically he expressed the view that both the (in house) designers and the main contractor were in comparatively "weak positions" vis-a-vis the client. The former he felt were inexperienced in this type of work: "(they've) been 'shoved through the tunnel' ... They've shown they can do it, but its been difficult". He referred to the fact that the job had been the "focus of attention" within the client organisations, and as such they could not push the main contractor for damages if the work was late due to the lateness of the design information. In normal circumstances, he felt, the main contractor "would have had a field day". Yet here the combination of it being run as a management contract, together with the contractor's aim of securing future work from an important client had led to a situation in which the two main parties had eventually 'collaborated': the "unique set of circumstances" surrounding the project had meant that working relationships had "developed well, despite the earlier problems". In other words, the key to an understanding of the outcome of the PDL project appeared to be the mutual dependency between the central parties involved in its management.

CHAPTER ELEVEN

INTER-CASE COMPARISONS AND CONTRASTS

The previous five chapters have described in some considerable detail the circumstances found and events reported on five quite distinct construction projects. The aim has been to provide as comprehensive and detailed a view as possible of the five case studies, in an attempt to explore fully the factors which in each case contribute towards an understanding of the processes at work in that particular project organisation. It should be re-stated that, in focusing upon five particular examples of construction project organisation and management, no attempt is being made to argue for the typicality or otherwise of these cases; nor is it argued that the cases represent in any way discrete models on a continuum of 'types' of construction project organisation. Instead, the intention has been to fully allow for the variety of circumstances found and to analyse within each case the association between particular configurations or patterns of such circumstances and the course of events on that particular project. The aim of this current chapter is to draw together the individual cases, to identify and discuss common themes occurring across the case studies, and to highlight comparisons and contrasts with respect to these themes. As a prelude to this exercise, an attempt will be made to broadly compare and contrast the sets of circumstances found across the five case studies. This will be done for two reasons. Firstly, to provide a resumé of circumstances on each case in such a way that allows for a direct comparison and contrast with circumstances found on other cases within the sample. Secondly, to highlight the factors that are of particular relevance to the subsequent inter-case analysis. The aim in this respect is to

provide a more concise descriptive backdrop for the later analysis and discussion. The procedure will be to compare and contrast the cases under broad headings which relate to the information contained in the earlier descriptive sections of Chapters 6 to 10, before turning, in Chapter 12, to a comparison and contrast of cases in respect of the structures and processes of management and of performance described in the latter sections of each case study chapter.

11.1 The Projects and their Context

The projects described in Chapters 6 to 10 varied considerably in the nature, type, scale, duration and complexity of the work involved: from the smaller scale civil engineering work on the RAW project, where the objective was to construct an infrastructure of access and drainage facilities, and where the work consisted entirely of external groundworks and basic structural work; to the larger scale PDL project where the objective was to construct a laboratory building with the full range of associated mechanical and electrical services, and where the work involved ranged from the excavation and laying of foundations through to the installation of internal fixtures and fittings. Moreover, these two specific projects marked respectively two important 'sectoral' distinctions in the sample of cases investigated: the RAW project was the only case studied in the civil engineering, as opposed to building, sector of the industry; the PDL project was the only case studied in the private, as opposed to public, sector. The only broad features that the five projects held in common were: that they were each 'new build' construction projects (as opposed to the refurbishment, maintenance or renovation of existing buildings or

other types of structure); they were each located on formerly unoccupied land or 'green field sites' (and did not take place directly in existing occupied areas, as might be the case on a maintenance or refurbishment contract); and they were each custom-built to a client's specification (distinct in this respect from, for instance, speculative house-building projects). Apart from these broad features the projects varied considerably along a number of dimensions. The intention here has been not to re-describe the projects according to these dimensions, but rather to state by illustration the heterogeneity of the cases in the sample across a number of dimensions (ie size, type, sector, etc).

However, it is also relevant at this point to direct attention to broad comparisons that can be made between the projects that have a significant bearing upon the interpretation of events in each case. In particular, when the projects are set in their context a notable distinction emerges in the aims and nature of the projects. Specifically, the first two case studies - the RAW and AFU projects - were construction projects that constituted in each case part of a longer-term and larger-scale development programme being undertaken by the respective client organisations. The remaining three case studies were, in contrast, of construction projects that were one-off developments with the aim of fulfilling specific and immediate requirements for additional or replacement capacity (the NSS project, despite it being linked with a second-stage contract, is here taken as a single development, rather than part of a longer-term series of projects). The RAW and AFU projects of course differed significantly in the type and scale of work involved. They also differed in their status with respect to

the wider development programmes: the RAW project constituted only part of a stage of development of the programme as a whole (ie the advance works for one housing estate); the AFU project constituted a complete stage in itself (ie the construction in total of an industrial estate). However, despite these major differences an important similarity lay in them being part of a continuing and wider programme of development. The client had in both cases commissioned work of a similar type and scale in previous stages of the respective programmes and was to continue to do so into the future. As such the work involved was of a recurrent nature and of a type and scale with which the clients (and designers) had had a good deal of direct previous experience. In this respect the work involved was not novel or unfamiliar. This is not to suggest that the two projects did not have their own specific requirements which significantly affected the design and construction processes (eg the adjustments needed to be made for variable geological conditions on the RAW site). However, it does suggest that elements of continuity and recurrence in the work involved were important underlying characteristics in each case.

This was not so for the three other projects in the sample. Each of these was a single, self-contained project (or development as in the case of the NSS), to be designed and built to the brief supplied by a known and specific user department (or departments) and with the aim of achieving a one-off increase in capacity in the short-term. While each may or may not have been linked with a longer-term strategy of expansion, as single projects they were not part of a continuing programme of construction in the same way that the RAW and AFU projects were. Each, coincidentally, also

involved the construction of a building (or buildings in the NSS case) housing laboratory facilities, and as such they were more 'services-intensive' than either the RAW project which involved no M & E services installation, or the AFU project where only essential amenities were installed. Again there were important differences in the nature and scale of the work involved: the NSS and MTS projects were perhaps similar in scale in financial terms, but the two involved very different types of construction - the NSS project being characterised by the extensive use of a system method of building for many of the main structural components; the PDL project was perhaps more akin to the MTS project in the type of construction involved, but was considerably larger in scale. Given these major differences, however, each project did share the joint characteristics of it being both a one-off venture, and one of a distinctive and somewhat unusual type (i.e. a building housing laboratory facilities). It is the nonrecurrent, distinctive and somewhat atypical nature of these projects that needs to be stressed here.

As a corollary to this point, the three projects can perhaps be considered less 'standard' or 'routine' than the RAW and AFU projects. As noted in Chapter 7 above, the architects supervising the work on the AFU project referred explicitly to that type of work being on the more "routine" side of the department's activities taken as a whole. No similar specific comment was made by those interviewed on the RAW project. However, the general tenor of the comments given concerning the nature of the work, the design for it and the process of construction point to a similar interpretation. Additionally the work involved was in each case somewhat

more repetitious and less fragmented than that involved in the construction of the three laboratory buildings: the AFU project involved the repeat construction of what the Site Agent called "basic shells" with few services; the RAW project involved a concentration of activity in a relatively smaller number of trades than in the other cases. In contrast, the laboratory buildings (excluding the NSS) each consisted of a single main frame construction, and (including the NSS) involved a more extensive range of types of activity - particularly in the services and finishing trades and in the fixtures and fittings and specialised equipment installed. This is not to suggest that the work involved on the RAW and AFU projects was any less complex, demanding or difficult. Rather that the characteristics of novelty, idiosyncrasy and fragmentation in the scope of the work being undertaken featured rather more significantly in descriptions given of the NSS, MTS and PDL projects, than they did in the descriptions given of the RAW and AFU projects.

A related but distinct feature that bears mention at this stage is the attention drawn to the 'prestigious' nature of the three laboratory case studies. The reference to the PDL project being the "centre of attention" within the client organisation for instance, suggests a level of 'visibility' and external interest in its development over and above that found on the RAW and AFU projects. A similar inference can be drawn from accounts given that referred to the perceived importance of the NSS project for the "reputation" of the architect's department, and the perceived usefulness of the MTS project in attracting public and trade attention. These comments were made from varying perspectives and for varying reasons

and will be returned to below in a fuller discussion of the aims and objectives pursued on the projects. The point here is that an added significance was attached to these three projects which was related to their status as one-off and distinctive construction projects.

The general point to emerge from this section is that, despite wide variation in the nature, scale and type of work involved on the five projects studied, a broad but useful distinction can be drawn between, on the one hand, those projects (ie the RAW and AFU) which comprised part of a recurrent series of similar projects, and, on the other hand, those projects (ie the NSS, MTS and PDL) which were one-off developments, distinctive in nature and where the range of types of work being undertaken was extensive.

11.2 The Participating Organisations

Before proceeding further, a general point needs to be raised concerning the use of the phrase 'the client'. Specifically that the generic sense in which the term tends to be used does not sufficiently allow for the complexity of what is the 'client body' in practice. A broad distinction has been made for the purposes of this study, for instance, between the client organisation as a whole (the Local Authority, Development Corporation, etc), the users of the facility (the polytechnic, private companies, etc), and the relevant funding bodies (the Treasury, pension funds, etc). However, in doing so it should be recognised that this represents a simplification of a more complex reality. For instance, only passing reference has been made to the specific 'client role' performed

by the housing and education departments (etc) in the public sector projects investigated. Indeed, the implications of a more complex client reality have received a good deal of attention in more recent studies of the construction industry (cf Bryant et al 1969, Friend et al 1974). An assessment of the implications of such features is beyond the scope of the current study. However, the existence of this complexity and of the ambiguities inherent in the use of the term 'the client' needs to be recognised.

A central feature of each of the five case studies investigated was that the main design functions involved were undertaken in-house. External consultants were employed for the design and supervision of M & E work on two of the laboratory projects (ie the NSS and PDL) and also for the surveying functions on two (ie the MTS and PDL). Conversely in other cases, use was made of in-house services for the M & E work (ie the AFU and MTS; there were no M & E services involved on the RAW project), and for the surveying functions (ie the RAW, AFU and NSS). However, in all cases the main architectural and (structural) engineering functions involved the employment of in-house specialists (the RAW project of course did not directly involve architectural designers; the NSS project, due to the policy of employing a system method, did not involve structural engineers). The particular configurations of patterns of internal and external employment in each case are given more fully in Figures 11.1 to 11.5 below. The point to be emphasised here is simply that the client's main agents undertaking the central design functions were in each case in-house, directly-employed specialists rather than external consultants contracted specifically for the project. With the exception of the RAW case where civil engineering was the main

Figure 11.1 The pattern of inter- and intraorganisational relationships on the RAW project

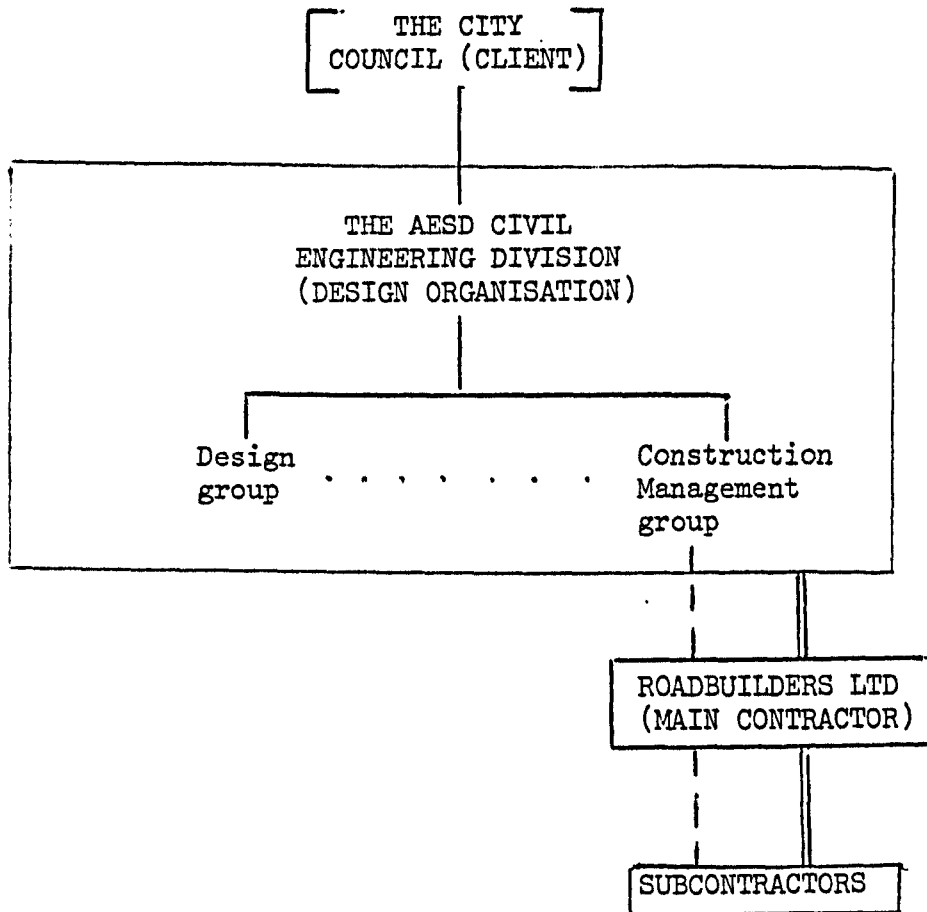

KEY: **====** Contractual relationship
 _____ Internal line management relationship
 Internal/external 'consultancy' relationship
 - - - - - Project 'line' relationship between organisations

Figure 11.2 The pattern of inter- and intraorganisational relationships on the AFU project

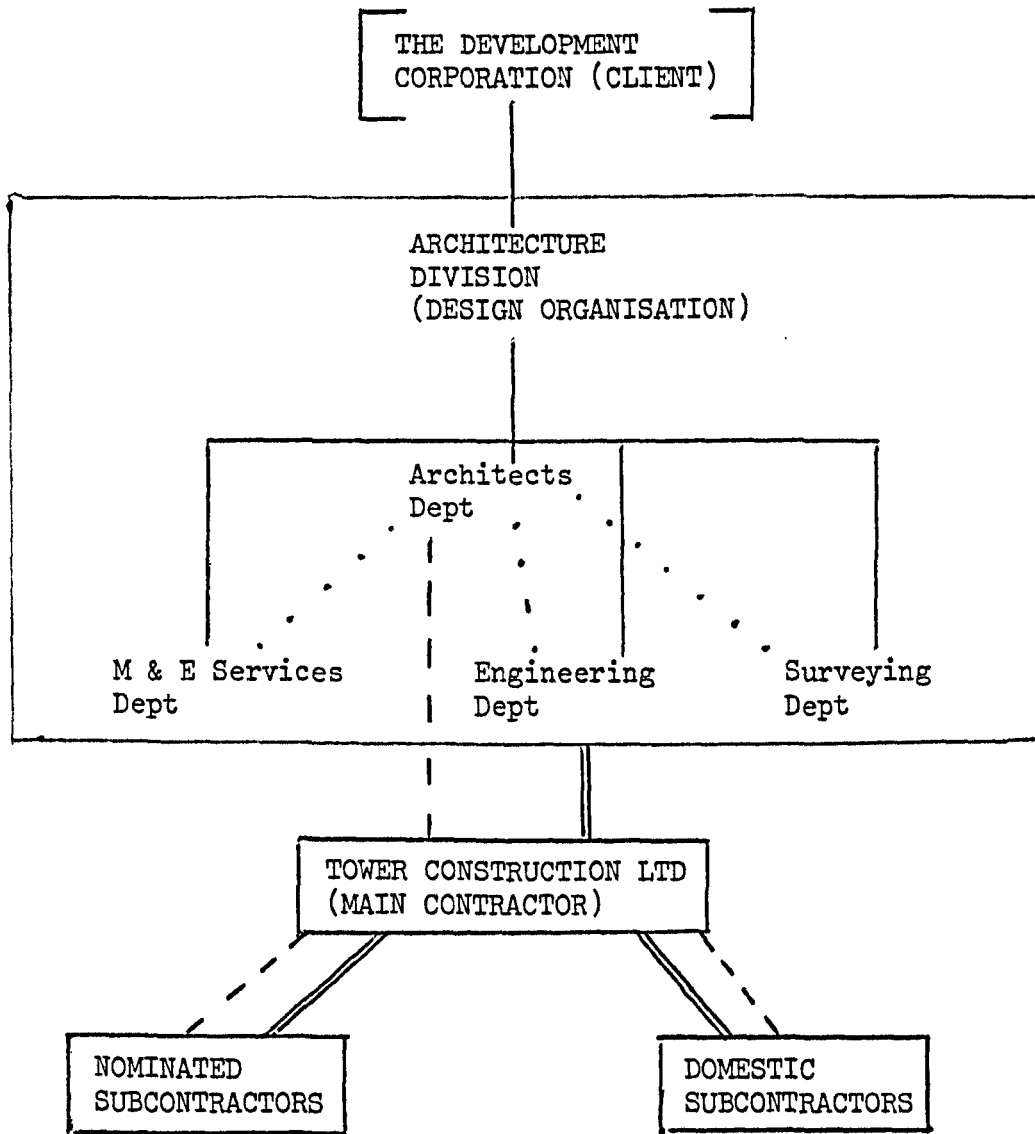

- KEY:
- ==== Contractual relationship
 - _____ Internal line management relationship
 - Internal/external consultancy relationship
 - - - Project 'line' relationship between organisations

Figure 11.3 The pattern of inter- and intraorganisational relationships on the MTS project

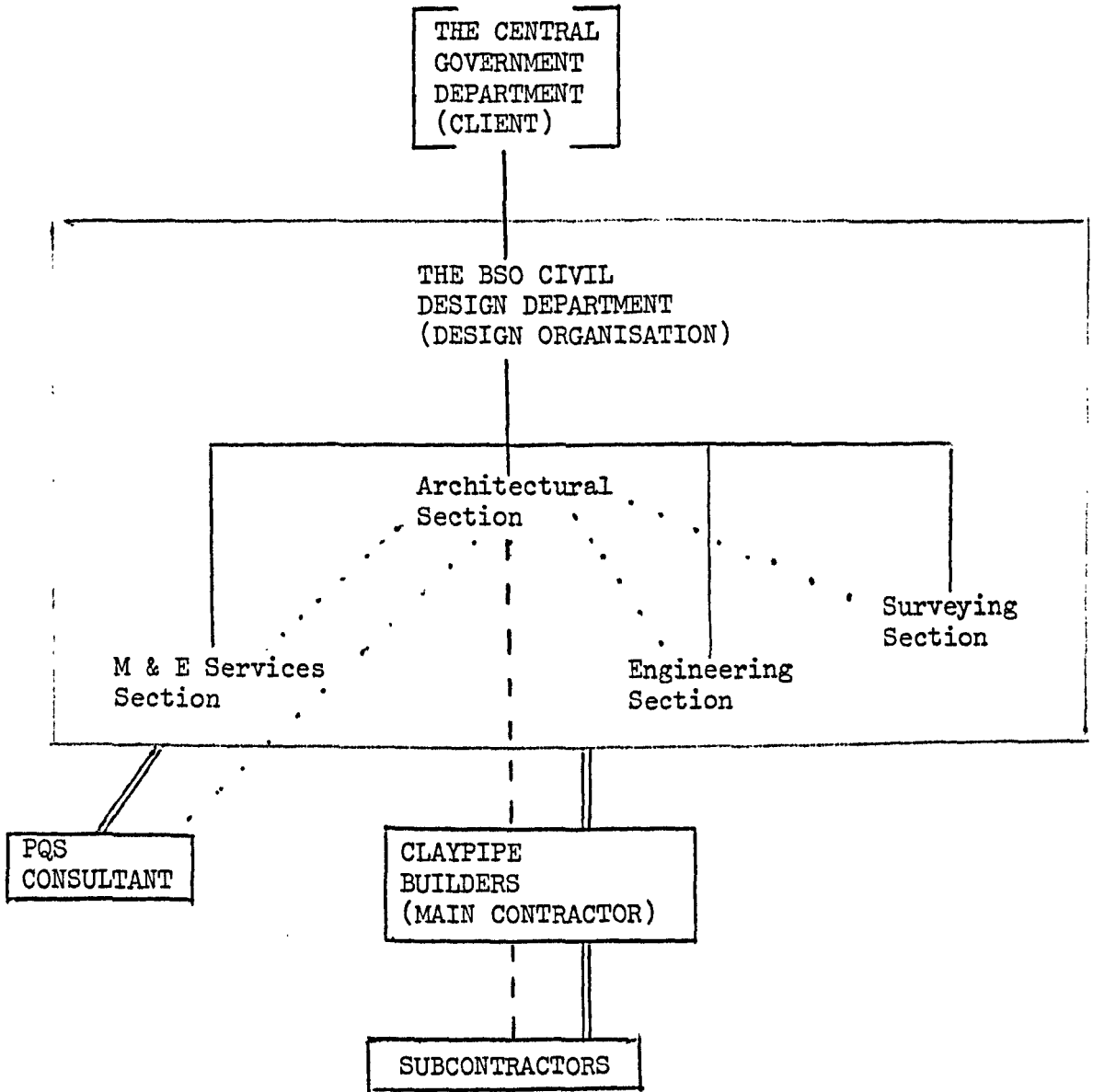

- KEY:• **====** Contractual relationship
—— Internal line management relationship
..... Internal/external 'consultancy' relationship
---- Project 'line' relationship between organisations

Figure 11.5

The pattern of inter- and intraorganisational relationships on the PDL project

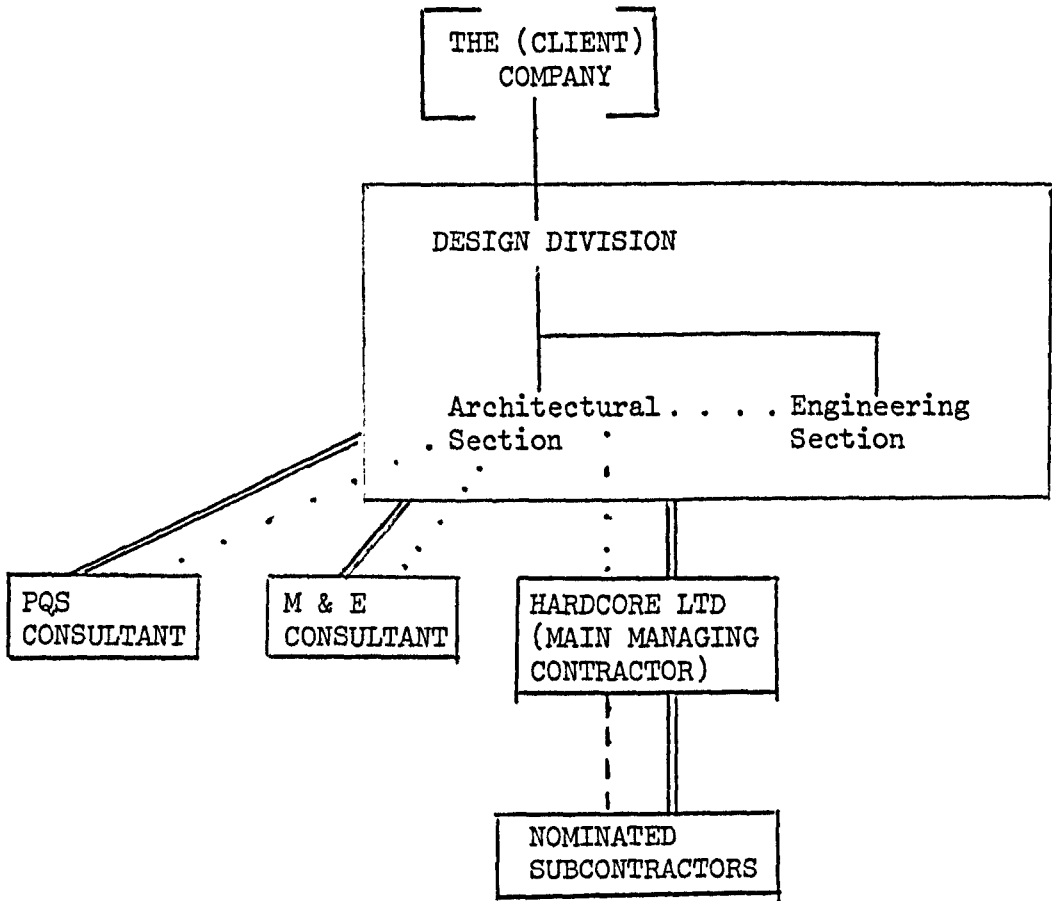

- KEY:
- ==== Contractual relationship
 - Internal line management relationship
 - Internal/external 'consultancy' relationship
 - Project 'line' relationship between organisations

design discipline, it was the architectural function which was the central discipline in this respect.

The previous section alluded to broad similarities and differences between cases in the level of experience in the particular type of work involved. In particular a broad distinction was drawn between the RAW and AFU projects on the one hand and the three laboratory cases on the other, as examples of recurrent and one-off projects respectively. No parallel distinction is to be made at this point with respect to the pattern of employment of clients' representatives, except to note that in both the RAW and AFU cases the pattern of employment was wholly in-house, whereas in the other three cases consultants were employed. Consequently to the extent that the management of the projects required the co-ordination of work undertaken by groups within distinct functional specialisms, the process was entirely internal to the organisation on the one hand, and partly external to the focal organisation on the other.

A more significant feature appears when the projects are set in the context of the relationship between each design organisation as a whole (eg architect's department) and their respective client organisation. Each case was one in which all the work undertaken within the design organisation as a whole was specific to the particular client organisation of which the design organisation was a part. In the NSS case for example, the Architects Department performed work solely for the County Council. Consequently the in-house design organisations were each fully dependent upon their client as a source of work, as opposed to undertaking work for a number and range of types of client. (Taking on board the earlier

point about the nature of 'the client', in practice the range of 'clients' may have extended to a number of specific local and central government departments - such as housing and education). However, in no case did the range extend beyond the umbrella 'client organisation' (- the County Council or Development Corporation, for instance.) However the reverse was not necessarily the case. The client organisations as a whole did not necessarily use in-house facilities to design and manage client-commissioned projects. Consultants were employed to varying degrees to perform specific functions (particularly M & E and QS) both on the projects studied and more generally. The tendency was also noted in some cases for there to have been an increase in the volume of work let out to external consultants and for this to possibly extend to the performance of 'core' design functions (eg architecture) in the future. Consequently while the 'market' for the services provided by the design organisation in each case was limited to the performance of client-commissioned projects, the design organisations were to varying degrees in direct competition (or potentially in direct competition) with similar services provided by external consultants. No firm data was given in the case descriptions which allows for a proper comparison of the degree of dependency in this respect. However reference was made to this as a background characteristic by various individuals interviewed in all the case studies bar one (the RAW).¹ Bearing this situation in mind, an important feature then emerges from a comparison of the projects which links back to the earlier comments made concerning the 'prestigious' nature of the work on the three laboratory cases. Specifically that in two of the laboratory cases - the NSS and PDL - the projects were significant in scale in relation to the volume of

construction activity as a whole managed by the respective design organisations. Further, they were consequently viewed as being somewhat 'critical' for the maintenance or development of the client's in-house design capacity. In the NSS case, reference was made to the importance of the project in helping the department secure further work from a client (the polytechnic) which had previously employed outside consultants for their work. In the PDL case, reference was made to the importance of the project in securing a shift in company policy away from a reliance upon external consultants for the design and management of 'industrial' projects and towards the employment of in-house services which had hitherto been employed mainly on the company's 'retail' projects. The two differed in this respect, in that for the PDL design organisation a large scale, industrial project represented to some extent a new departure in the scale and type of work undertaken, whereas the same cannot be said for the design organisation on the NSS project. However, in both cases the inference is clearly that the projects had a wider significance that stemmed from their size in relation to the volume of work undertaken generally by the respective departments, and from their consequent 'strategic' significance. The data presented in each case do not allow for anything but the most tentative conclusions to be drawn in this respect, since little information is given concerning internal strategic decision-making processes at higher levels within the respective client organisations. However the accounts given do suggest that this feature was a significant underlying dynamic in the view of many of those interviewed in each case.

No similar observations were made with respect to the other

three cases in the sample. In the case of the MTS project, the Contracts Manager referred to the job being a prestigious one from the builder's point of view - a point that will be returned to below. However, no comments were made that allow the inference to be drawn that the projects held in any way a position of strategic importance for the respective design organisations. In each case the design organisation managed a large number and range of different types of construction project, of which the cases studied were not atypical in either scale or type. The MTS project was perhaps distinctive in being a custom-built laboratory building. However it was not a sizeable project in itself and was both small in relation to the volume of work handled by the design organisation for the client, and by no means an exception to the types of project the design organisation had undertaken in the past. Similarly, the RAW and AFU projects - while in each case forming part of a broader and sizeable development programme - were not in themselves 'critical' to the design organisation in the same way that the NSS and PDL projects were perceived to be. In other words, the impression given that the NSS and PDL projects represented to all intents and purposes 'test cases' is not an impression that can be gleaned from accounts given of the circumstances and events on the MTS, RAW and AFU projects. This is not to suggest that the achievement of objectives on these latter three projects was in any way a less important consideration than on the NSS and PDL projects. Rather that success or failure in achieving the objectives on these two particular projects was felt to have potentially wider implications for the position and role of the in-house design departments with respect to the wider client organisation.

Turning to the main contracting firms involved on each of the five projects, there were again major differences between them along a number of dimensions. While the firms employed on the AFU, MTS and PDL projects were large contractors, operating nationally and with extensive interests in various sections of the construction industry at home and abroad, the firms employed on the RAW and NSS projects were much smaller and operated almost exclusively in their regional or local market. The firms employed on the AFU, MTS and NSS projects operated as 'general building contractors', while the firm on the RAW project specialised in the construction of marine and civil engineering works, and the firm on the PDL project was distinctive in specialising in management and fee contracts only. These features are cited only as illustrations of the differences between the firms employed as main contractor across a variety of dimensions, and of the factors to be borne in mind in the following discussion. At this stage the point to be made is that the firms employed differed dramatically in their size, specialisms, breadth of operations and types of market served.

Following the thread of the earlier discussion, it is interesting to compare and contrast the status of each project with respect to the firm employed to undertake the work. Again circumstances varied considerably between cases, and the aim is not to give a complete picture of each case, but rather to highlight salient characteristics to parallel the earlier discussion of the status of the project with respect to the design organisations. The first point to be made concerns the distinctiveness or otherwise of the project in relation to the type and scale of work involved. Here there was no evidence to suggest that the scale or type of work involved was such as to be

beyond the capacity and previous experience of the firms employed to undertake the work. The RAW and NSS projects were perhaps large in relation to the firms' current level of turnover. However they were not untypically so, nor untypical in comparison with the types of work that each firm had undertaken in the past. Steelframe, for instance, was a firm that to a certain extent specialised in the type of work involved on the NSS project by virtue of a long-standing relationship with the County Council as client and a corresponding level of experience of working with the department's system method of building. Roadbuilders, although they tended to specialise in the construction of marine engineering works, had in the past undertaken large, one-off civil engineering projects. In the other three cases the projects were comparatively smaller in relation to the company's level of turnover, and not untypical of the types of projects that the companies - as large national contractors - had undertaken in the past. This was perhaps most clearly the case for Tower Construction on the AFU project. For Claypipe on the MTS project, the project was distinctive but small compared to other projects undertaken in the past. For Hardcore on the PDL project, to the extent that the management contracting approach tended to be adopted for the management of large, complex projects anyway, then the scale and type of work involved on the PDL project was by no means exceptional.

A perhaps more significant dimension emerges when the firms are compared with respect to their experience of performing work for the same client (and design team) and - a related point - the significance of the projects for company objectives and strategy. On the latter aspect, it need hardly be mentioned that the general

economic climate at the time made the industry a 'buyer's market' and one in which a contract won with a large and influential public sector client was 'good news' for the firms concerned. Each of the clients in the five cases studied was indeed 'an important client' from the builders' point of view in terms of their high levels of expenditure on new and remedial construction work. The focus varied from the national importance of the BSO as the main agent for central government-commissioned projects such as the MTS, to the local significance of the County Council as a source of work for firms like Steelframe employed on the NSS project. However in all cases a level of dependency on the client for current and future work underpinned the relationship between the parties to the contract. The degree of dependency in this respect differed between cases - both in relation to the current significance of each project with respect to the company concerned, and in relation to the importance of the client as a continual past (and potential future) source of work. On the first point, there was a marked difference between those firms for whom the projects studied were significantly large in relation to their current level of turnover (Roadbuilders and Steelframe on the RAW and NSS projects respectively) and the rest. On the second point, a continuing dependence upon the client as a source of work was most noticeable in the relationship between Steelframe and the County Council in the NSS case. However it was also noticeable in the relationship between the client and contractor in the AFU and MTS cases, where the current project formed one in a series of recent construction projects commissioned by the client for which the main contractor had been employed. Furthermore, there was the anticipation - expressed explicitly in some cases, more implicit in others - that this relationship would

continue. In other words, having undertaken (successfully) one or a couple of projects for the same client, then the firm's chances of being re-employed in future would possibly be enhanced or at least maintained. This anticipation was most clearly manifested in the PDL case, where the strategic intention was to exploit the opportunity available for capturing a major share of the projects commissioned in the future by that particular client. However similar strategic intentions also formed part of the backdrop in other cases: in the MTS case, for instance, specific reference was made to the importance of the project in winning back client orders after a previous and unsuccessful project; in the NSS case the expectation was that experience on that project would enhance the firm's chances of successfully bidding for the follow-up work; in the AFU case the possibility was there of obtaining future orders for work on the continuing factory development programme, or other (eg housing) programmes undertaken by the Corporation; the same was presumably true for Roadbuilders in the RAW case, although here events took a rather dramatic turn with the collapse of the company. The general point to be stressed here is simply that, while the projects varied in their direct significance for the firms undertaking them (as a proportion of turnover) and in the extent to which they were part of a wider current dependence upon the client (in terms of the volume of work undertaken for that client), in each case they assumed a strategic importance by virtue of the client being an important and continual source of work in general. In this sense, while the projects were each - from the main contractors' viewpoint - won as single, one-off contracts, they each represented one in a series of actual or hoped for and anticipated future transactions with the client organisation.

As a corollary to variation in the level of current and past dependency upon the client as a source of work, there was variation too in the patterns of experience of each of the participating organisations (and individuals) of working with each other. Again the most long-standing of relationships was that between the County Council's Architects Department and Steelframe on the NSS project, where the prior experience of working together had been extensive at both an organisational and individual level. On the AFU and MTS projects working relationships were also to some extent characterised by prior experience and some degree of familiarity - again both between organisations and respective team members. It was only the RAW and PDL projects which constituted a completely novel and unfamiliar pattern of working relationships between organisations and individuals (this refers only to the relationship between the in-house design team and main contractor. In the PDL case, the consultants had had extensive prior experience of performing work for the client - in some cases in conjunction with their in-house team; and the PQS consultancy had at least worked with Hardcore before.) This point is relevant since the initial stages of the projects' development in each case were notable for the learning processes which underscored interaction between the parties: in the RAW case this was manifested in the head-on clash between the parties' two senior representatives; in the PDL case this was reflected in comments directed towards the early lack of "communication". In contrast, a level of familiarity and prior experience of working together in the MTS case, for instance, informed the main contractor's approach towards the management of this contract: note the account given of the Site Agent's remit to keep "nagging" at the design team for information and instructions.

Again it should be stressed that patterns of working relationships between organisations, groups and individuals differed considerably in the extent to which prior experience formed a part. However, the notion of recurrence or non-recurrence applied to the pattern of working relationships between parties appeared to be a relevant dimension in the study of the dynamics of the processes of interaction in each case.

The previous two sections have attempted to compare and contrast the cases investigated with respect to the broad context within which the projects were undertaken. In doing so, attention has centred upon, firstly, the nature of the project in terms of the aims it represented and the extent to which it was distinctive and non-recurrent. Secondly, upon the participating organisations' involvement in terms of the extent to which the project represented part of a continuing and longer-term dependency upon the client organisation, and its significance in this respect; and the extent to which it represented a 'new departure': both in the type and scale of work and in the pattern of inter-organisational relationships established to undertake the work. The argument that is being pursued is that these issues highlight factors which are of critical importance in an understanding of events during construction across the five cases investigated. This section deals with a third set of features which, it is argued, also have an important bearing upon subsequent events in each case - namely the situation and circumstances as they were in the period prior to that which is the focus of attention in this study (ie the construction period). It should be reiterated at this point that the 'database' from which comparisons and contrasts are to be drawn consists of information obtained from relevant documentation backed up by entirely retrospective accounts of the processes involved prior to construction. As such the 'data' is both lacking in full detail with respect to the processes involved, and selective rather than systematic in scope - reflecting a strategy of exploring the 'pre-history' of specific issues that emerged during construction, rather than giving a panoramic view of the pre-construction period itself. The reliance

upon retrospective accounts in turn suggests a caution in interpreting past events on account of the potential for distortion arising from ex poste rationalisation and selective recall on the part of those interviewed. This section intends briefly to highlight salient features of each of the projects studied in respect of three broad sets of issues: firstly, the nature of the work involved and characteristics of the design process - specifically the degree of 'overlap' between design and construction stages; secondly, the tendering arrangements and the procedures involved in the letting of the main contract; thirdly, features of the main contractor's plans of work drawn up during tendering, and in particular, the pattern of subcontracting.

The first series of points concern the nature of the work and the status of the design for it in each case. As noted earlier, the three laboratory cases included in the sample were distinct in the level and intensity of services work involved. They were also distinct to the extent that the work involved was less recurrent, less repetitive across the works as a whole and more fragmented in the types and numbers of trades involved than that found in the two remaining cases (the RAW and AFU). This greater level of variety and complexity in the work was reflected in the comments reported concerning the nature of the design, and the extent to which the projects were characterised by a continuation of the design process into the construction period. In the RAW case, the work was regarded as being fully specified by the time work began on site; in the AFU case, there was some 'overlap', although the comments made by the architectural staff suggested that the degree of 'overlap' and its effects were minimal. In the three laboratory cases, however, a significant amount of work to be built was not fully specified by the

time work began on site: in both the NSS and PDL cases, this was related to the lack of time available for detailed design work; in the MTS case, reference was made to the effects of the M & E design process being held over until the appointment of subcontractors, despite there being a fully detailed specification available for the main structural work. This latter instance points to a general issue concerning the design process - namely, the extent to which the design for the services work in particular was dependent upon the more detailed designs and shop drawings submitted by (nominated) subcontractors who were only appointed relatively late on in the preconstruction planning period. Corresponding to this, the tendency for the design process for the M & E works to run concurrently with the actual process of construction on site. That this created problems in the co-ordination of work on the MTS project was made clear in the accounts given. The difficulties experienced were regarded as less severe in the other cases, although the complexity of the work in this respect and the potential for problems occurring in the co-ordination of services and main building work was nevertheless explicitly referred to. The main point to be stressed here, however, is that there was an important difference between the laboratory and non-laboratory cases in the sample in the extent to which the continuation of the design process into the construction period emerged as an issue. In the laboratory cases the continuation of the services design, coupled (in two of the three cases) with an initially incomplete detailed design for the main building work put greater emphasis upon the co-ordination of design and construction processes while work on site progressed. In the other cases either a clearer demarcation between the stages or the more straightforward characteristics of the work involved - or both - served to reduce the potential difficulties arising from problems in design/

construct co-ordination. As a corollary, the perceived potential for variations occurring in the design for the works was somewhat less in the two non-laboratory cases - a factor related to the somewhat more straightforward nature of the work, but also to the rather more fixed and definitive designs for the works, stemming from the projects' recurrent nature and their basis in a 'non user-specific' brief. In general terms, the design and construction processes in these cases were more loosely 'coupled' than they were in the three laboratory cases. In those cases a closer relationship between the ongoing design process and construction on site was to be expected, and its effects were evidenced in the accounts given.

The second series of points concern the tendering arrangements for the letting of the main contract. In all cases bar one (the PDL), the main contract was let under a 'standard' form of building contract (the ICE or JCT conditions), following a process which had involved the choice of the lowest bid for the work from a shortlist of selected firms.² As such the process followed a 'traditional' pattern of letting arrangements in which the main contractor was not involved in the early broad and detailed design stages of the project and their role in the continuing design process was limited to putting in requests for detailed and additional information needed for current and advance planning of the work on site. The use of a management form of contract on the PDL case was quite distinct in this respect in that the main contract was negotiated; the terms and conditions under which the firm was employed as managing contractor reflected their role as a member organisation of the client's team; and their involvement in the project commenced at a much earlier stage than that of the firms in the other cases - their role in the design process then being much more direct

and extensive. An additional but related feature of the PDL project was the change that occurred at the tendering/detailed planning stage that arose due to the client company decision to reduce the budget available for the project. In the four other cases, the main contract was let under a set of terms and conditions that contained a fixed programme period for completion and, once the contract was awarded, a set price for the work. In the PDL case, in contrast, the change in the financial target for the work occurred subsequent to the main contract negotiation and very much at the eleventh hour in the pre-construction design and planning processes. The implications of this change were described more fully in the accounts reported in Chapter 10. For the purposes of this discussion the point is to note that it was only in the case of the PDL project that the baseline performance criteria were changed in any way once the main contractor was appointed. In other cases, the procedure involved the main contractor submitting a price for the work to be produced within a contractually-specified time limit, from which point the time and cost targets to be achieved for the work were set.

The final series of points to be made in this section concern the main contractor's plans for completion of the work and, in particular, the use of subcontracting. Again the PDL case was highly distinctive given the purely managerial role performed by the main contractor. Apart from providing a direct labour gang to perform 'general services' on site, the work was subcontracted (to about 40 firms) in its entirety. The main contractor's central aim was to ensure that the contractually-agreed programme for completion was met. In doing so the main contractor performed a key role in managing the two-way flow of information between the design team and subcontractors. In managing

the process of construction on site, emphasis was attached to the role performed by the main contractor in planning in detail the work to be done to individual subcontractors' own programme completion dates and in co-ordinating the separate trades work across the site as a whole. This specialisation in the actual process of managing construction rather than undertaking any of the work directly was a key feature of the PDL case, and one which distinguishes it from the other four cases in the sample. In these cases some combination of directly undertaking the work (especially in the main trades - eg groundworks, joinery, bricklaying), and subcontracting particular specialisms was the norm. However, even in these cases, the use of subcontracting as a mechanism to perform the work appeared to be a widespread modus operandi. The reasons underlying the decisions as to whether to subcontract or perform various aspects of the work directly - and whether this reflected project-specific considerations or broader strategic considerations within the firm, have not been given here and are beyond the scope of this study (for a fuller discussion of this topic see, for example, Bresnen et al 1985). The point here is that each of the cases investigated involve the quite extensive use of subcontracted firms - variously providing labour, plant and/or materials to perform the work. The complete use of subcontracting in the PDL case was an extreme manifestation of this, and a central feature of the contractual method employed. A further feature is that all the cases bar the RAW and MTS projects involved the employment of formally nominated subcontractors to perform work - mainly in the more specialist services and finishing trades (eg mechanical and electrical services, ceilings, windows installation). In the MTS case, the absence of nominations was the consequence of the specific terms and conditions employed (ie GC/Works/1), although here an element of tacit

recognition, in practice, of nominations was a feature of accounts given on the project. In the NSS case in particular, but also in the AFU case to some extent, the use of nomination extended further to the employment of materials and component suppliers - in the AFU case, this was reflected in the use of 'preferred' suppliers of fittings. In the PDL case, the use of a management form of contract meant that all subcontractors were formally nominated, and employed under the corresponding set of terms and conditions used for nominations in a more 'traditional' setting.

The point here is that the main contractor's role in each case included a significant emphasis upon the forward planning and on-site integration of subcontracted firms' work. With the employment of both nominated and/or domestic subcontractors to perform the bulk of the work in all five cases, the main contractor's role was concerned with providing a largely management-only input to the performance of the work, as opposed to directly undertaking the bulk of the work itself. The use of nominated subcontractors differed in the extent to which the responsibility for their work was shared with the design team representatives. However, with both nominated and domestic subcontractors the central feature was that the performance of this management function was based upon a relationship that was external to the main contracting organisation involved, rather than contained within an internal hierarchy. The underlying mechanism was the contractual exchange relationship between the parties which specified the terms and conditions of employment for the duration of the construction period, and not authority relations based upon an internal hierarchical chain of command.

The main series of points to be made in this section concern the process of design and the patterns of involvement of design personnel in that process; also the relationship between the design and construction stages in the organisation and management of the project. Taking the latter point first, it was only in the case of the RAW project that a clear distinction existed between the teams of in house staff involved in the pre-construction design process and the construction stage itself. In that case, the team involved in construction supervision took over from where the design team left off. In all the other cases, those involved directly in the project's design - the architectural and engineering staff - were directly involved in the job's supervision through to completion and handover. The situation on the MTS project differed noticeably in this respect to the extent that the BSO's secondment practices meant a de facto distinction between design and construction supervision personnel. However, even in this case, while individual role-holders changed during the course of the project cycle, the organisational location of participants did not. It was only in the RAW case that the disjuncture between design and construction stages of the project was matched by an organisational separation of roles - into design team and construction supervisory personnel (the secondment of the design engineers to the site was, as noted, specifically geared to staff training and development needs). In all other cases a change in the role performed by the client's representatives was the significant feature: the architect's role, for instance, changed in nature from designer to supervisor as the functions involved changed from design to construction supervision. Similarly for the other

specialists seconded to the project management team. This continuity of involvement across stages of the project cycle and the consequent change in roles performed by members of the client's team, contrast with the more explicit demarcation found in the RAW case. Unfortunately, this demarcation makes it difficult to explore in much detail the pre-site design process and organisation in the RAW case, since few of those involved at that stage were interviewed. However, the stage-related pattern of involvement is itself of some interest. For each project such as the RAW project, design engineers from the appropriate group were seconded to the project team to prepare a detailed design for the works which was based upon an advance works brief translated by the two co-ordinating groups from broader architectural plans for the site. From there the construction engineering section took over, seconding to the site a team of staff to supervise the actual construction of the works. Due to the very specific nature of the work involved, there was no direct continuing involvement of staff from other specialisms (eg architecture, planning, design engineering) during the course of construction in the same way that there was during the construction of the other four projects in the sample. Instead, the team supervising the construction of the work was contained within, and seconded from, a single organisational subunit - namely the construction engineering section of the relevant construction group within the division. It was consequently more uni-disciplinary in its composition.

The implications of this more 'unitary' organisational context during construction on the RAW project will be returned to below. At the moment it is noticeable how this pattern of involvement contrasts with that found in the other four cases in the sample. In those cases, project team members followed the project through from its initial

design stages to completion (excepting that the direct involvement of particular specialists - eg structural engineers - was of shorter duration than others). As with the RAW project, staff were also seconded on a job-by-job basis, although in the other four cases this was less specific to the type of work undertaken (cf the specialisation in the RAW case between groups involved in the design and management of Riverside projects and those performing other operational and service work). More significantly however, the 'teams' as such consisted of (groups of) personnel from quite distinct functional groupings who were seconded to the team (variously on a full- or part-time basis) either from departments within the in house design organisation, or from external consultancies which had been contracted to undertake design and/or supervision work on the project. (It should be noted here that the focus is upon the four central functions involved - namely architecture, (structural) engineering, services engineering and surveying - although it is recognised that the 'team' did not in all cases consist solely of members of these four disciplines.) Leaving aside for the moment the issue of whether the relationship was an internal or external one, the project team in each case consisted of a multidisciplinary group of specialists, backed up by their own teams of designers and technicians, whose involvement continued to varying degrees across the stages of the project cycle as a whole, and who undertook complementary functions geared towards the achievement of project objectives. As such the structure of roles and relationships established amongst members of the project team exhibited characteristics indicative of the existence of matrix management as broadly defined by Knight (1977). That is, each senior specialist with their departmental teams was seconded (full- or part-time) from their own section to act as the representative

responsible for overseeing the work connected with that specialism on the project. In the case of those involved part-time, their concurrent activities extended to work on other departmental projects at various stages of development. Once individual projects were completed (or that section's work on them finished) their direct involvement ended. The 'home base' in each case was the relevant section within each department, and the 'resource manager' (following the matrix scheme) was the section head. The individual who co-ordinated the project-specific contributions was in each case the designated (architectural) Project Manager, and the relevant project axis of the matrix corresponded to the chain of command, within the architectural department. While some of these relationships were external to the focal in house organisation (where M & E and PQS consultants were employed), organisationally a similar pattern existed with senior individual representatives becoming part of the project management team. In both cases (internal and external) the representatives managed their own team of designers and technicians to undertake the work. Unfortunately no details were obtained on the organisational structure and process of management in this respect, and consequently no attempt at analysis of this aspect will be made here. A similar caveat needs to be made concerning the placement and secondment practices of senior specialist staff within each design organisation as a whole. In taking the construction project as the unit of analysis, little information was obtained on the patterns of involvement of senior staff (eg whether full- or part-time) across the wider range of projects undertaken. Given these limitations, what is interesting to note about the structure of the design organisation in each case is the centrality of the architectural design discipline in providing the 'core' around which individual

project teams were organised, and the role of senior architectural staff as those primarily responsible for the co-ordination of project work across the disciplines involved. What this suggests is a pattern of matrix management ostensibly similar in broad outline to Sayles' (1976) 'internal consulting services model', with the notable exception that the relationships were in some instances external to the focal organisation. More generally the pattern reflects features characteristic of Knight's (1977) 'secondment model' of matrix management in which the balance of power tilts more in the direction of the project, rather than functional, hierarchy.³

However, at the same time, this broad categorisation is misleading, since what is particularly interesting about the five cases studied is the nature and extent of their variation with regard to these dimensions of matrix management. Of particular importance are the position, role and authority of the Project Manager in relation to representatives from other specialisms both within and between cases. An illustration of these differences is given when circumstances on the NSS project are contrasted with those on the AFU, MTS and PDL projects. The implications of differences along these lines will be explored more fully in the later section that compares case histories and the dynamics of the relationship between the main parties during the construction period. However the issue is worth noting at this point since it is one that assumes a particular prominence in the accounts given in each case. In the NSS case, the internal structure of the design organisation was such that in house staff were seconded from specialist teams within the architectural division to project teams under the direct jurisdiction of an architectural Project Manager. The surveying division in this case

performed a direct role in pre-contract and post-contract administration, but only an indirect role with respect to work undertaken during construction. Senior staff within that division retained functional authority over members of the surveying team within the architectural division; they also performed a 'maintenance' role within the department as a whole, being responsible for staff resources and development. However, the core project teams consisted of specialist staff within the architectural division whose work on specific projects came under the direct and full jurisdiction of senior architectural staff. The position of the Project Manager in this case extended beyond that of being responsible for co-ordinating the work undertaken by specialists seconded from separate departments, to a position of more direct influence over in house project team members' contributions. The employment of M & E consultants in that case corresponded more closely to the conditions under which the architectural Project Manager performed a 'co-ordination' role. However, the internal structure reflected much more closely conditions consistent with a more centralised and unitary pattern of control over project team members' contributions. As such, the influence of the Project Manager was more direct, and the project axis much more clearly the basis of organisation within the department as a whole.

In the three remaining cases, in contrast, the accounts given suggested a much more fragmented pattern of control, consistent rather more with conditions associated with the 'co-ordination model' end of the matrix continuum. In the MTS case in particular, explicit reference was made to the difficulties experienced stemming from the lack of control over the contributions of design specialists (particularly the M & E) seconded to the project design team, suggesting

that the 'co-ordination' role expected to be performed by architectural design team staff was hindered by the relative autonomy of these specialist sections within the overall design organisation. In the AFU case, the implications of similar difficulties emerging were hinted at in comments directed towards early 'internal problems' within the design organisation, although the lack of data on this point precludes anything but the most tentative suggestion that this reflected a manifestation of conditions latent in the structure of organisation. Perhaps more significantly in this case and in this respect is the observation that the management of the M & E function operated in a parallel fashion during the course of the construction period, and was somewhat distinct from the main architectural chain of command in this respect. A similar observation can perhaps be made concerning the M & E function on the PDL project, although here an external consultant was employed rather than design services being provided in house. Internally, it should be noted that many of the comments made concerning the early lack of "communication" within the team as a whole were set in the context of the totality of relationships within the architect/structural engineer/main contractor triumvirate, and not simply directed towards the design team/main contractor relationship. To the extent that the problems were located in the relationship between in house design groups, then this would point to a similar interpretation concerning the rather more limited role and influence of the architectural staff as co-ordinators of the 'project team'. when compared with, say, conditions in the NSS case.

The above comments are not intended to permit the location of each of the five project design teams along a continuum of patterns of matrix management such as described by Sayles (1976), Knight (1977)

or Galbraith (1973). The data obtained do not allow for such a full classification. Nor, since the focus is on specific projects, do they allow for a consideration of the broader structural features of the design organisation in each case. Furthermore, the data suggest a variety of circumstances within each case: in the NSS case, for instance, distinctions emerge when one compares the internal structure of relationships on the one hand with the use of independent and separate external consultants on the other. The intention is instead to assess broad relative tendencies in the project teams' configurations across the cases. What the above commentary does suggest is that the tendency on the MTS, AFU and PDL projects was for there to be a much more fragmented pattern of control exercised over the performance of work on these projects, than that exhibited in both the RAW and NSS cases. While the architectural (or civil engineering in the RAW case) design team formed the 'core' of the project team, and while their senior members were the central figures in co-ordinating work across the various disciplines involved, their position vis-a-vis other departments varied: the more direct influence of senior staff on the RAW and NSS cases over team members' contributions, contrasts with the greater degree of functional (and/or organisational) autonomy of the separate specialisms within each of the other three cases. As such, the tendency in the former cases was for a pattern of matrix management that exhibited characteristics symptomatic of a move towards the 'secondment model' end of the matrix continuum, whereas the tendency in the latter cases was for a pattern exhibiting characteristics symptomatic of a move towards the 'co-ordination model' end of the matrix continuum.

In contrast to the more fragmented pattern of control found within the design team in each case, the organisation established for the management of work on site by each of the main contracting organisations followed a more unitary and cohesive pattern. For each project a team of site staff, most of whom were transferred from completed projects elsewhere (as opposed to being recruited or seconded from head office departments), were brought together to manage the work under the direction of a Site Agent acting as the company's senior representative on site. Head office staff who had been involved as key members of the 'management team' in the planning and tendering period prior to work starting on site (ie the Planner, Engineer, Surveyor, Buyer etc) then performed a largely administrative support role for the site management team acting in the field. In a manner similar to that described for the client's staff involved on the RAW project, the teams involved in project planning and construction site management were separated to some extent. In the main contractors' case, the firms' Contracts Departments took over as the 'line' management for each project, while head office planning personnel performed staff roles in providing services or information requested from site on an ad hoc basis, and retained functional authority with respect to the administrative procedures adopted (for personnel management, requisition procedures, etc). The most significant direct part played by head office staff was in managing the flow of resources to the site - via materials and plant requisition procedures. Otherwise each site team operated with a considerable degree of autonomy in conducting the detailed management of operations on site - information on progress being fed back to the variety of head office staff providing 'back up'

support services, but the most direct channel for communication between site and head office being via the Contracts Department hierarchy. Given the more indirect part played by head office staff in the management of work on site, there were few examples of the relationships described extending to a more direct and influential level of functional influence in the performance of work on site that would be symptomatic in any way of the existence of a dual structure of command. While it has been argued that functional authority relationships may be included under the umbrella term of matrix management (Knight 1977), in most cases this appeared to be the limit to the level of direct influence exerted over the site management team by functional specialists and, as such, indicative of only very incipient matrix features.

However, one or two instances did occur in which a duality of reporting relationships appeared to be a significant feature. Interestingly, these instances pertained in all cases to the performance of the financial/contract administration function performed on site by QS staff. In the RAW and PDL projects, both senior surveyors were seconded on a part-time basis from their respective head office departments. They were not resident on site and their concurrent activities extended to performing work related to other projects at various stages in their development. The same was the case for the MTS and NSS projects, although here these activities were performed directly by staff supervising the job from head office level - the tendency not to employ specialist surveyors on site being a consequence of the limited scale of the work involved in each case. Only in the AFU case was the performance of this function contained wholly within the scope of the site team, and resident staff employed full-time to

undertake the financial measurement and evaluation of the work.

Elsewhere, the performance of the surveying function was distinctive in the extent to which it stood apart from the more operational side of the site management team by virtue of the level and nature of head office staff involvement in its performance. What is interesting about the RAW and, particularly, the PDL projects in this respect is the inference - from the comments made concerning the role and position of surveying staff on each project - that there existed to some extent a 'distance' between the surveying and 'operational' staff on each site. It will be recalled that on the RAW project the QS described his own involvement with other members of the site team as "minimal" in a situation in which the day-to-day management of the work was characterised by a high level of direct, personal contact between staff on the production, engineering and administrative sides. On the PDL project, reference was made to a slight status differential that existed between the financial and operational staff. Such a distinction provides an illustration of Sayles and Chandlers' (1971) discussion of the distinction between "business system" and "technical system" role-holders. The RAW case is particularly pertinent in this respect since the account given of relationships within the site team centres upon just such a distinction in orientation that contributed towards a conflict of interest between financial and operational staff. In that case the Site Agent represented the former set of interests in his capacity as being responsible for overseeing the firm's financial progress on the project. As a more general comment, it would appear - given the position and role of financial staff across the projects and their position as "aides" or "advisors" to the company's senior representative on site - that the 'balance of power' within each team was tilted more heavily in favour of "business

system" considerations. Given the centrality of the contractual dimension to an understanding of the process of management in construction this is by no means surprising. What however is noticeable is the extent to which this was manifested - in all bar the AFU case - in an organisational configuration of roles and relationships that drew out the distinctiveness of "business system" role-holders in an otherwise more unitary pattern within the organisational subunit set up to manage the construction process. In other words the distinctiveness of the surveying function and of the individuals employed to undertake it, and the close working relationship with the senior site representative coupled with retained links with head office, marked out the performance of this role from others undertaken within the construction site management team.

With the exception of the surveying staff, for most of the staff employed by the main contractor in each case, the pattern was of a more straightforward and unitary configuration of relationships, in which the Site Agent performed the central co-ordinating role in managing the process of construction on site, and the main point of contact with visiting and head office based staff. In the earlier, larger cases studied - the RAW and AFU cases - the reported level of 'site discretion' in taking project-related decisions was high, and the teams were in general agreement that the site operated with a significant level of autonomy with respect to their head offices - in effect acting as self-contained, autonomous project units within the wider organisation. In the two smaller projects - the MTS and NSS cases - the level of involvement of head office supervising (and surveying) staff was more pronounced in the sense that more frequent and regular contact with the site team occurred. In the NSS case this

was manifested in a greater level of head office staff involvement in contractual dealings with third parties - a situation that arose largely as a consequence of the loss of the Site Agent from the project and the problems reported by the main contractor's staff in their dealings with the designers. In the larger PDL case too, the involvement of the visiting Contracts Manager centred largely round monitoring the financial progress of the work and undertaking contractual dealings with third parties in conjunction with the company's surveyor. In the first two cases - the RAW and AFU projects - these activities in contrast were devolved more fully to the level of the site. It was the Site Agent (together with the semi-resident and resident QS respectively) who in each case conducted negotiations with clients' representatives and subcontractors and whose remit emphasised their role in the financial management of the project on behalf of the firm. Given the difficulties in establishing a basis for comparability between cases in the absence of more exact data, it is difficult to conclude that authority was more decentralised in these cases. However, given the general tenor of the comments and drawing a broad distinction between the site and head office level in each case, it appeared to be the case that a greater level of site team autonomy was in evidence in the RAW and AFU cases, when compared with the situation on the two smaller projects, and, for reasons related to the distinctiveness of the management form, the PDL case. A further and related point is that variation in the level of involvement in this respect was linked to the management of the contract as opposed to the direct management of operational work on site. The general point to be raised from this discussion is that the more significant part played by senior company staff in the management of the project may have been a feature of the smaller scale of the work (as in the

MTS and NSS cases), a response to a change in the organisation and/or problems in external relationships (in the NSS case) or the specific characteristics of the arrangement employed (in the PDL case).

However in all cases, it was the contractual dimension in the management of work on site that tended to form the nexus in the continuum between local site autonomy and more direct central office control.

Footnotes

- 1 In fact the ARE who was interviewed did express his belief that a future intention was a merger of the Council's housing and transport engineering design capacity, which would lead to a reduction in overall in-house capacity.
- 2 The GC/Works/1 form is here included despite its dissimilarities, due to the essential similarity of the tendering and contract-letting processes.
- 3 Given that the project hierarchy was contained within the 'core' (ie architectural) function.

AN INTER-CASE ANALYSIS

The previous two sections have looked at the broad structural configurations of the 'design' and 'construction' teams established to manage the work on site, and in particular concentrated upon the extent to which the location and role of participant team members in each case contributed towards a fragmentation of control over the construction process. In this respect, the central point to emerge is the contrast between the existence of a 'model' of organisation within the design team in which features symptomatic of a variety of forms of matrix management occurred, and the more unitary and cohesive 'model' found within each contractors' team, bearing in mind the broad "business system" - "technical system" distinction referred to. The aim of this section is to provide an overview of the process of construction management across the cases, with particular attention directed towards patterns of lateral interaction amongst the participants from the various organisations involved.

12.1 The Organisation and Management of Work on Site

The first theme that should emerge from a review of the relevant sections in each case concerns the intricate nature of the process of management itself at the operational level and in particular the complex of factors and changes in circumstances influencing the performance of organisational work on site. The essentially static picture given of the process of management in each case does not lend itself fully to exploring either the variety of factors taken into account in planning the work at various stages of the construction cycle, given the range and shift in the types of work involved (ie through substructure - superstructure - services - finishing - external trades' task work), or the changes involved in this process.

However, the descriptions given do suggest the relatively short-term orientation towards the management of work on site and the extent to which the detailed planning of the work was highly iterative and dependent upon previous performance with respect to more broadly established interim completion dates and targets. In resourcing the work, a similarly complex picture emerges of the processes involved in ensuring that labour, plant and materials were brought together to perform particular tasks at the right place and the right time, given the planned programme of work, current performance levels in relation to that work, and interdependencies with other trades. To the extent that such work was subcontracted, or resources obtained via schedules of deliveries of plant and materials to site under orders placed with contracted suppliers then an additional set of activities were associated with negotiating and agreeing contractual terms and conditions with third parties, organising and establishing schedules for construction and/or delivery, and supervising that work on a daily or weekly basis to ensure that the planned programme was adhered to - given in the meantime that current performance levels on site may have affected the ability to meet deadlines for delivery and schedules of work agreed with the third parties concerned. The picture is of a complex and interdependent set of activities involved in the management of work on site where conditions were highly variable and the situation changed literally in many instances from day to day. Add to this complexity and variability the impact of modifications to the detailed design for the works on the basis of either directly-induced design changes or due to circumstances that emerged in the construction of the works itself, and one is confronted with a more complete picture of the difficulties associated with the management of construction work on site. What is particularly

interesting about the entire process is the extent to which it defined a situation in which the management of the work as a whole involved participation in decision-making across organisational boundaries. The management of the continuing design process was particularly pertinent in this respect: in each case reference was made to the process of establishing detailed drawings for the works in the context of a contractually established specification of methods and materials to be employed and quality standards to be achieved. Yet to the extent that design details were not already firmly established (eg with M & E services) or variations occurred in the design or 'snags' emerged as the work was built on site, then a significant emphasis was put upon establishing in detail the work to be done on site involving each of the key organisations concerned (designer - main contractor - subcontractor) in agreeing or negotiating changes to the work with consequent implications for their own plans of work. It was the undercurrent of change and variability in this respect and in relation to the broader plans established for the work that provided a central dynamic in the process of management during the construction cycle. More specifically it was the three laboratory cases in the sample in which such dealings during the course of construction appeared to be of major significance.

The issue is then raised of the implications of this situation for the patterns of interaction between parties in the management of the project - particularly insofar as problem-solving and decision-making processes are concerned. The more general question is to what extent the pattern of interaction observed exhibited characteristics associated with a tendency towards a more 'organic' structure of roles and relationships (Burns and Stalker 1961) within the project

'organisation' as a whole. The first point that should emerge concerns the very variety and complexity of the patterns of interaction involved. This was particularly the case on the three larger projects in the sample in which: larger resident site teams were employed on behalf of the main contractor; a greater number of clients' staff at various levels and from various specialisms were involved in the projects' design and supervision; and a larger number of subcontractors were employed - each consisting of a non-resident head office team which had been involved in planning out the work beforehand, and a resident site team which directly undertook the work. Simply taking three core organisations (designer, main contractor, subcontractor) each employing a central office staff and project site team suggests the level and complexity of the patterns of interaction involved by virtue of the mathematical possibilities (see Figure 12.1). Add to this the multiplicity of organisations involved in any one case (particularly the number of subcontractors, but also separate design specialisms) and the range of possibilities becomes virtually endless. Before moving on, it is useful to compare the extensiveness of patterns of interaction between individuals from separate organisational groupings with findings obtained in other industrial and commercial settings (Mintzberg 1973; Stewart 1967, 1976). While this dimension has not been quantified, it is interesting to note the extensiveness of lateral, extra-organisational contacts at the 'operational' level, since such contacts in other settings have tended to be found to be more pervasive at more 'strategic' levels within the firm (Mintzberg 1973). The extensiveness of such contacts is consistent with the findings that relate external contact to the level of interdependency between subunits within organisations (Sayles 1979, Yanouzas 1964). What is of interest here is the fact that such contacts are prevalent

Figure 12.1 Internal and external patterns of interaction: a depiction of the possibilities

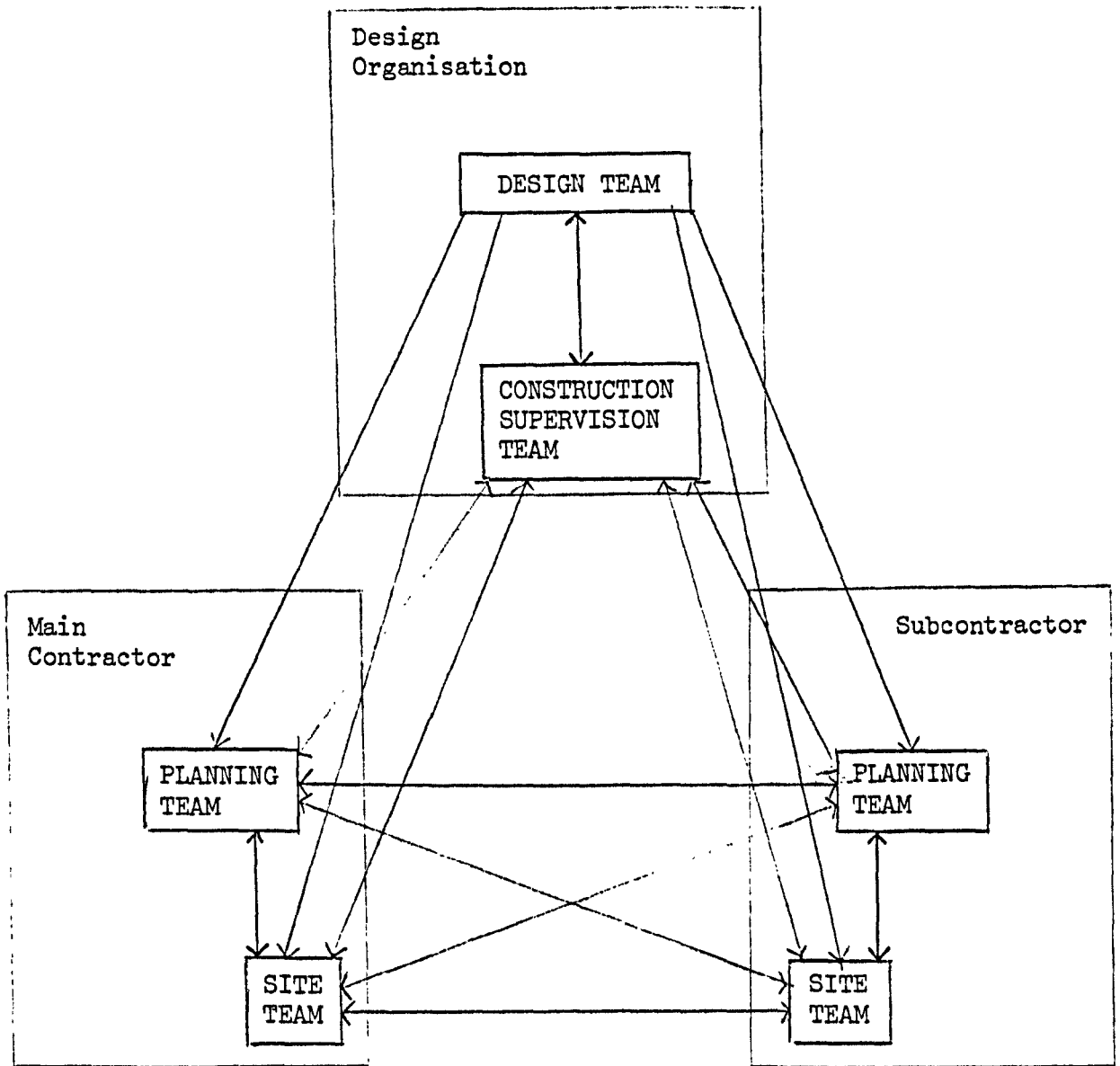

between members of separate organisational subunits. Such a degree of contact with 'outsiders' (Mintzberg 1973, p44) suggests perhaps a point of departure in the investigation of the nature of managerial work in construction. An exercise of charting the patterns of interaction and changes in them throughout the course of each construction cycle is well beyond the scope of this study. What is of interest are the broad tendencies and differences between cases in the pattern of interaction between respective team members and the factors which determined the levels within the total 'project organisation' at which problems were solved and decisions taken.

An important feature to note in the pattern of interorganisational management of projects concerns the use of 'domestic' and 'nominated' subcontractors to undertake major sections of the work in each case. In the RAW case, it was noted that members of the client's team tended to liaise directly with (domestic) subcontractors' representatives on site, as well as "work through" the main contractor in supervising the work and resolving any problems that arose on site. Similar tendencies were noted in the other (architectural) cases in which resident Clerks of Works and visiting Job Architects would deal, to varying degrees, directly with subcontractors' representatives in discussing the work on site and any problems that arose as much as 'work through' the main contractor. Such tendencies would suggest a more complex pattern of lateral interaction between parties than the 'chain of command' set up in the structure of contractual relationships might imply, and to this extent, a less structured pattern of working relationships between the teams. More important, however, was the extent to which the establishment of a detailed design for the works to be produced and the monitoring of the work in respect of its

design involved direct interaction and dealings between members of the design team and the subcontractors concerned. This was particularly the case where nominations were involved. In these instances, a more direct channel of communication was set up between design team and subcontractor reflecting the aim of producing a detailed design for the works and monitoring the quality of production of (off site) components. In the M & E work, for instance, the establishment of a fully detailed design was dependent upon the preparation of detailed drawings and plans by the subcontractor concerning the layout and routing of mechanical ductwork and electricity cables. In the main building work the production of component units (eg windows, panels) involved some level of interchange over the establishment of a detailed architectural specification for the work in question. Indeed, the use of nominations reflects the intention of there being a closer working relationship between design team and subcontractors in the establishment of a detailed design. In the case of 'domestic' subcontractors, the assumption is rather that all design dealings are conducted indirectly - the main contractor in effect being taken as the organisation which undertakes the work, whether or not the main contractor then chooses to subcontract that particular task or not.

What was interesting about two of the cases in particular (the PDL and the MTS) was the extent then to which perceptions of the contractual position with respect to nominations had implications for the management of the work on site. In the PDL case, where all subcontractors were nominated, illustrations were given of the tendency for design dealings to be sometimes conducted directly between the design team and subcontractor, in the process causing the main contractor to be 'cut out' from performance of their co-ordination role.

In the MTS case a similar tendency was noted in some instances (eg the windows subcontract; the M & E work). In terms of the management of subcontractors, such tendencies suggest the existence of a duality in the control exercised over subcontracted work to the extent that the performance of the work involves continuing interaction concerning design detailing and quality control. This situation - with respect to architectural and services work nominations - is depicted in Figure 12.2. The types of problems that occurred during construction centred around the introduction of (minor) design changes that emerged as 'snags' later on in construction. The problem that arose with fitting the panels on the main frame columns in the PDL case supplies a useful illustration. In that instance, changes that occurred in the design in a situation in which there was some ambiguity as to which party was responsible for checking drawings and picking up 'snags' in the design, meant that the problem did not surface until the last possible moment. The argument then arose as to which party was responsible for not spotting the effects of the design change at a sufficiently early stage. The MTS case perhaps provides the clearest example of the extent to which the potential ambiguities of the contractual position led to a situation in which direct and continuing design interaction created problems in the construction of work on site. Interestingly, the MTS case also provided an example of the extent to which such dealings were accepted or encouraged or they were not: in the co-ordination of M & E designs, for instance, there appeared to be a greater acceptance, on the part of the main contractor, of direct dealings between the designer and subcontractors; whereas in the architectural sphere, such a tendency to 'by-pass' the main contractor was not so readily accepted or approved of. More generally, comments

Figure 12.2 Patterns of Dual Management in the Performance of Subcontracted Work

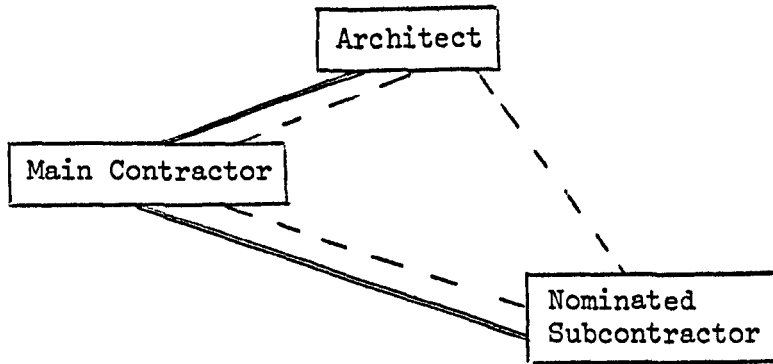

(a) Architectural nominations:

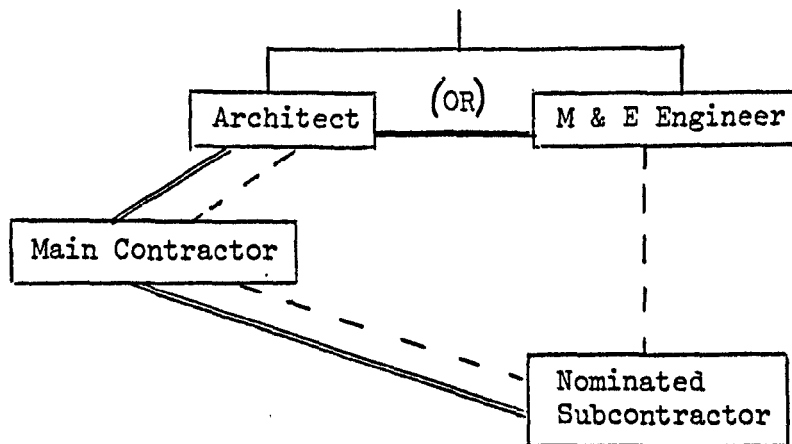

(b) M & E nominations:



Key:

-  Contractual relationship
-  Project management relationship

were made that suggested the importance of maintaining a 'balance' between continuing close and direct contacts between designer and subcontractor to establish a detailed design for the work, and some level of main contractor control over that process in order to ensure that problems would not subsequently emerge in integrating that work with other work on site.

The more general point is that such a situation suggests the existence, or potential for existence, of a dual structure of management with respect to the planning, co-ordination and control of subcontracted work. It was interesting that the PDL and MTS cases provided examples of the types of problems that might emerge given such a dual structure, since these two projects were also the two that involved distinctive (and to some extent unfamiliar) patterns of contractual relationships. In the PDL case, all subcontractors were nominated, and the main contractor's role in design dealings was purely as a 'go-between' since the firm undertook none of the work directly. In the MTS case, although there were no formal nominations, the pattern of design dealings appeared to correspond much more closely to a pattern characteristic of a more 'traditional' setting. In that case in particular, there was interpreted as being some confusion, ambiguity or divergence of opinion concerning the respective parties' rights and obligations with respect to the management of subcontracted work. In the remaining three cases, the tendency for such problems to occur was not marked - perhaps due to the less complicated processes involved in the RAW and AFU project; but also perhaps due to the more 'traditional' contractual arrangements, and the clearer mutual understanding of each others' roles, previous experience of one another, or a combination of these factors. What

this suggests is that a latent contractual ambiguity in the use of nominated subcontractors may have been triggered by the differential sets of assumptions and expectations brought to a somewhat unusual type of arrangement by the parties involved. This led to the jurisdictional ambiguities noted in the MTS and PDL cases and the resultant conflicts and arguments. It is not intended here to explore in detail the occurrence of conflict or co-operation between the parties in this respect. However, it is relevant to note the existence of jurisdictional ambiguities at the inter-organisational level (Kochan et al 1975) and the tendency for these to occur in the context of shared control (Filley and House 1969; Kochan et al 1975) over the design and construction of subcontracted work.

The more general point is that such conditions reflect the tendency towards a matrix pattern of management at the inter-organisational level in which the two main parties (designer, main contractor) both exert some level of direct control over the design and construction processes for nominated work. It was interesting that the employment of the main managing contractor to perform an 'integrator role' in the PDL case represented the adoption of a structural mechanism to avoid the problems stemming from potential ambiguities. Whereas the MTS case was one in which some pattern of mutual adjustment to the formal contractual position formed the mechanism. What is of further interest in both cases is the way in which differential assumptions and expectations of the parties' roles informed their approach towards this issue in a situation in which an ostensibly definitive, but at the same time relatively novel and unfamiliar, administrative arrangement was used. It was the particular sets of assumptions made in each case which formed the basis for a move away from the formal contractual position which stressed a delineation of each parties' rights and obligations, towards a more flexible - but also more ambiguous - arrangement, in which the potential for problems

stemming from dual control over the work was realised. In other words, differences in orientation towards the management of the design process with respect to subcontracted work tended to promote conditions in which jurisdictional ambiguities stemming from shared control of the total design - construction process were realised.

12.2 Roles and Relationships within the Inter-organisational Matrix

Figure 12.2 above illustrates some differences between the pattern of design management and supervision for architectural and M & E nominated work. The difference between the two is that in the latter case it operates at one step removed from the central project 'hierarchy'. The implications of this have been touched upon in referring to the situation on the MTS project. The intention here is to explore more fully the structure of management established for the M & E works since the picture compliments further the picture of fragmentation in the control exercised by the design team described in the earlier section, 14.4. What is particularly interesting about the M & E side is its location within a discrete functional discipline. This was viewed as having implications for patterns of interaction across organisational boundaries for the performance of this work and for its integration with the main building work. Taking as an example the PDL case, what was noticeable about the M & E side was that the M & E consultant, the main contractor's Services Manager, and subcontractor site (and to some extent head office) representatives formed the key figures in the management of the M & E design and construction process - forming an identifiable sub-grouping within the project organisation as a whole. Where problems arose with the design and construction of the works that had no direct implications for the architectural design, the budget or the programme of works, it tended to be this sub-group which

were directly involved in resolving them. The PDL case was distinctive from the other cases in the sample in the fact that an individual member of the main contractor's staff (the Services Manager) specialised in the co-ordination and control of the M & E work, forming an intermediary between the design team and subcontractors. However, the existence of a 'parallel' structure for the supervision of the M & E services work was not limited to this case: note the description given of the pattern of involvement of the design team in the supervision of work on the AFU project, and the 'by-passing' of the main contractor in the MTS case. The NSS case additionally provides an interesting example of the types of problems faced by members of the architectural design team in dealings with a firm that both designed and built the mechanical components. However, the main point to stress is that what was commonly found across the cases (with the exception of the RAW project) was a combination of functional specialisation on a horizontal basis within the project organisation as a whole, that crossed boundaries between the organisations involved in the design and construction of the work. The situations observed in the PDL and MTS cases are given as illustrations of this phenomenon in Figure 12.3. While these are only broad depictions of what in reality were more complex webs of interlocking relationships, they nevertheless provide a useful backdrop to a discussion of the comments made concerning the integration of the M & E and main structural work in each case.

What was of further interest about these configurations were the comments made concerning the tendency towards 'differentiation' (Lawrence and Lorsch 1967) along the horizontal axis. The clearest example of this occurred in the accounts given by members of the design team in the MTS case. References were made to problems experienced in the

Figure 12.3 The Management of the M & E Function

(a) The PDL Project:

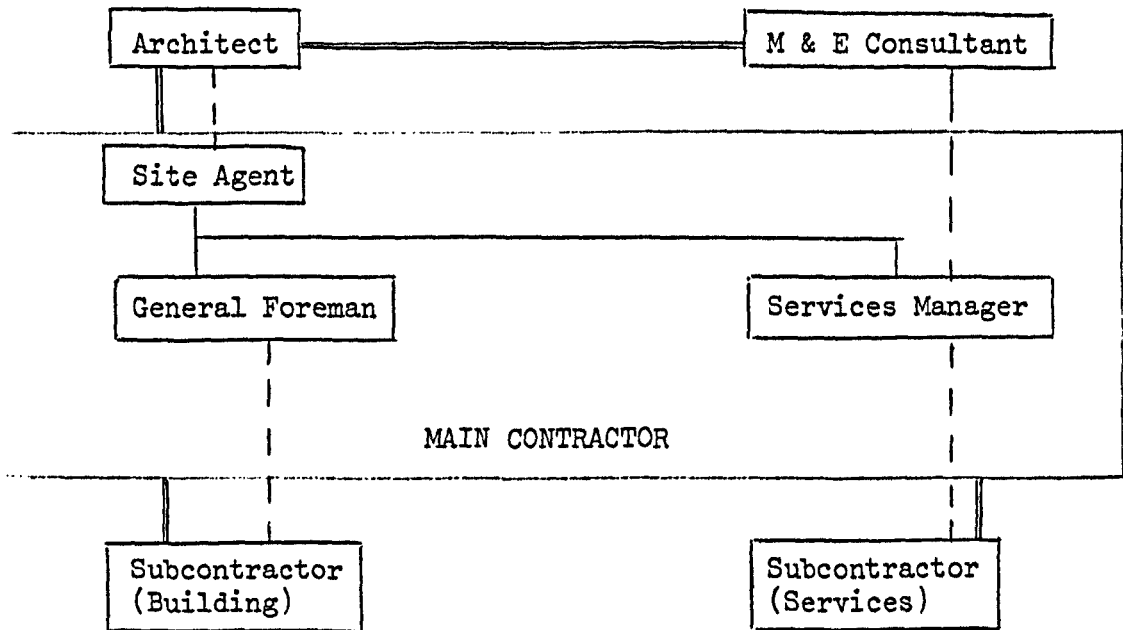

(b) The MTS Project:

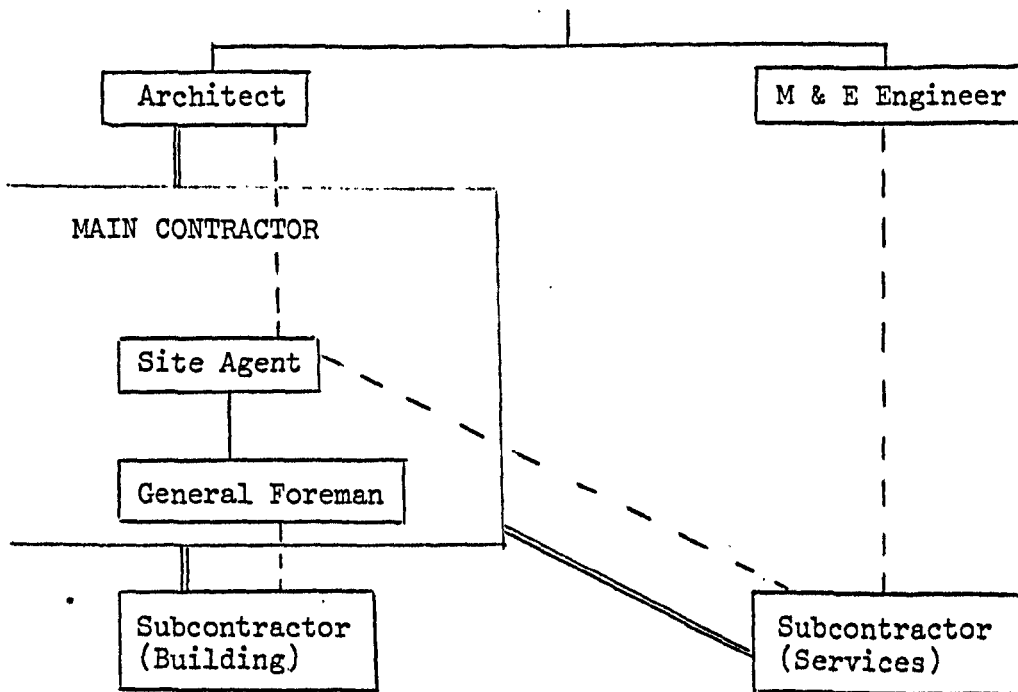

Key:

- ==== Contractual relationship
- Internal 'line' management relationship
- - - External project management relationship

level of commitment of M & E engineers to the project team - an observation that has been made of interdepartmental working relationships in other types of project system (Weiner 1970, Schein 1970). More broadly, the differential knowledge bases involved in the distinct areas were suggested by the comments made concerning team members' specialisation on specific aspects of the work and, in particular, the reference to a distinct "design logic". The other side of the coin was presented in general descriptions given by the M & E consultant employed on the PDL project. He commented, for instance: "Not many architects appreciate engineering services work because they concentrate mainly on what it looks like". In describing one particular example, he suggested that: "Architects basically see ceilings as a 'membrane' that conceals (the M & E works) ... (but) they're critical to the M & E design (as) engineering constraints ... It's a continual problem trying to educate architects into realising the engineers' problems". Juxtaposed with the earlier reported comments given by architectural staff, the implication is that a divergence rather than convergence of views on basic design issues may tend to be the norm. While the data reported do not extend to a consideration of differentiation across the range of dimensions suggested by Lawrence and Lorsch (1967) - eg time orientation, formality of structure, etc - nevertheless the reported comments do supply a flavour of the tendencies towards differing orientations towards the construction process based upon differing functional design perspectives. In the MTS case the configuration of relationships between design team members and the peculiarities of the secondment practices adopted served to augment the effects of these tendencies - such that a divergence in orientation towards specific project goals was engendered. However it was the difference in design perspective

that appeared to exist as an important underlying factor.

What was of further interest about the MTS case was that this divergence in perspective between design team members was contrasted with a perceived convergence in perspective amongst M & E specialists across organisational boundaries. The comment concerning a different "design logic" was made to suggest a closer understanding of design issues between M & E specialists across the organisations involved than between design specialists from different disciplines in the same team. The point was not only that dealings in this aspect of the work involved closer direct contact between members of the respective teams, but also that such contact was based upon a closer cognitive understanding. What is interesting to note about this case was the manner in which these factors (divergent orientations within the multidisciplinary design team; fragmented patterns of control over the design process; the development of close M & E designer - subcontractor working relationships) combined with the contractual ambiguity noted earlier, to produce a level of "dissociation" (Kingdon 1973) between the main building and M & E services sides of the project. The point here is that the distinctiveness of the main building and M & E work generates a tendency towards differentiation which, following Lawrence and Lorsch's (1967) scheme, puts an emphasis upon establishing an appropriate level of integration. In the absence of sufficient internal mechanisms in the MTS case to secure the level of integration needed, and in a situation in which the contractual position tended to encourage the main participants (architect, main contractor) to 'stand back' from the process of M & E design and design co-ordination, it is perhaps not surprising to find that the pattern of extant working relationships depicted in Figure 12.3

led to a situation in which there was in effect some 'de-coupling' of the main building and M & E sides of the project, with the consequences described in Chapter 8.

In the two other cases in which the co-ordination of services designs and their installation were prominent features (the NSS and PDL) such a level of 'de-coupling' did not occur. However, both cases were interesting in their own ways. In the NSS case, the employment of the firm to fully undertake the mechanical work may have internalised, hence making closer, the relationship between designer and producer. However, according to members of the architectural design team it contributed towards widening the gap between design team members through allowing the firm to 'play one side off against the other'. What was particularly significant about the PDL case was the position and role of the main contractor's Services Manager performing an 'integrating role' in two respects: firstly, by providing an extra link between the main building and services sides of the team; secondly, in providing the link between the M & E consultant on the one hand, and the subcontractors concerned on the other. In this case the involvement of an individual to perform this integrating or co-ordinating role signified the adoption of a more explicit mechanism to co-ordinate and control work on this aspect of the project. In the MTS case, in contrast, the accounts given suggest that co-ordinating and integrating the work was left to rely rather more heavily upon individuals' predispositions and attitudes towards becoming involved in that process at one level, and the response of contracted organisations towards undertaking this role at another.

The discussion so far has concentrated upon noting tendencies

towards differentiation within the project organisation as a whole

- in this respect the M & E function has been singled out for attention and reference has been made to the different integrating roles performed. What is of equal interest is the broad relationship between 'design' and 'construction' processes within the project organisation and the mechanisms employed and roles performed in the translation of the design for the work into its construction on site. The earlier discussion of the impact of cross-cutting design dealings with respect to nominated work in particular served to illustrate some of the problems involved. More broadly the question was one of securing a more tightly 'coupled' working relationship between design team and construction team members of the project organisation - particularly in those cases (ie the MTS, NSS and PDL) where the design process ran to some extent concurrent with the construction of work on site. The PDL case was of particular interest in this respect in that the main contracting organisation explicitly performed an 'integrator role' - acting as intermediary or linking-pin between the design team and (nominated) subcontractors. What was particularly interesting about the comments made by members of the site team in this respect was the attention directed towards the conflicting requirements it then engendered. The references towards the conflict between upholding the client's interests and supporting valid subcontractors' demands - a series of comments validated by the comments made by members of the design team and the (panel) subcontractor interviewed - were indicative of a form of 'role conflict' (Kahn et al 1964) - albeit at an organisational level. For individual members of the team, the comments made concerning their strategies of coping with subcontractors' demands on site illustrated the caution that was exercised in a situation in which factors affecting the work were

largely beyond their control, and their power to take decisions without referring back for approval was limited. It was interesting that, in the early stages at least, few of those interviewed were satisfied with the type of arrangement adopted in these respects. Ostensibly, the employment of a 'neutral' main contractor should have eased the problems of 'communication' between 'design' and 'building' sides, through allowing for a clearer understanding of each others' position and problems. In practice, and due to the particular sets of circumstances surrounding the project, early developments were characterised somewhat more by ambiguities and conflicts surrounding the interpretation of the main contractor's role. In the longer term, the inference to be drawn from the general tenor of the comments given by members of the design team, the main contractor, and at least one subcontractor, is that the inherent ambiguities and conflicts were resolved by virtue of the main contractor associating itself much more clearly with the design team's interests. The comments made by the subcontractor representative concerning the level of "support" given by the main contractor in the subcontractors' dealings with the design team suggest that the aim of allowing for the 'representation' of subcontractors' interests as well had not necessarily been achieved.

What was also of some interest in the relationship between 'design' and 'construction' across the cases was the position and role of the client's Clerk of Works as the individual who formed the most direct point of contact between the design and construction teams. At this point it should be restated that there was a notable distinction in the pattern of supervision by the client's team on the RAW project when compared with the other, architecturally-based teams

in the sample of cases. In addition to the point noted earlier - concerning the less fragmented locus of control over the construction process - reference was also made to that subunit's autonomy vis-a-vis central office and the discretion of senior staff on site in conducting project dealings with the main contractor's representatives. This picture - of devolved and site-based direct supervision of the works - stands in interesting contrast to the pattern in each of the remaining (architectural) cases. Here design team members rather than 'construction' staff were the individuals primarily responsible for supervising the work, and reference was made in most cases to the extent to which there was also more centralised control exercised over the construction process. In the NSS case, for instance, explicit attention was directed towards the more extensive involvement than usual of staff at higher levels within the design organisation in the direct monitoring of activity on site, and the manner in which decision-making within the organisation was as a consequence a more centralised activity. The observations made concerning the restrictions on the authority of the Clerk of Works in the MTS case, the control exerted over the Job Architect and Clerk of Works in the AFU case, and the early tendency in the PDL case for instructions to be issued directly to the main contractor (rather than via the Clerk of Works), point to a similar - albeit less marked - tendency. The point here is that the pattern of control exercised within each of the architecturally-based design teams described tended not only to be more fragmented, but also more centralised in comparison with the situation found on the RAW project, where decisions could be reached by the staff on site without the need for prior design team, or 'head office' approval.

As noted in many of the architectural cases, the position of the clerk of works was also somewhat peculiar in that individual staff were seconded from distinct sections or departments within the client organisation to the architectural team, and were then directly accountable to architectural and engineering design staff for the direct supervision and monitoring of the works. This rather more explicit instance of matrix management along 'secondment model' lines is particularly interesting when coupled with the observation that the clerks of works' authority to take decisions and issue instructions to the main contractor tended to be curtailed, and also when juxtaposed with comments made concerning expectations of the role to be performed by the clerk of works in supervising and monitoring work on site. In both the AFU and NSS cases, it will be recalled, reference was made by the architectural staff to the potential vulnerability of the client's building representative faced by a main contracting organisation pursuing the representation of its own interests in dealings with the design team. In the AFU case this was interpreted as the contractor potentially "running rings round" the Clerk of Works; in the NSS case it was interpreted as a desire not to allow Clerks to get in the position of "covering" the contractor's mistakes. In the NSS and MTS cases, the Clerks of Works' authority was formally limited; in the AFU and PDL cases, the limits appeared rather more to derive from a stylistic interpretation by senior designers of how to approach the management of the team. The point here is that a dependency upon staff seconded from another section to perform the function of direct supervision of the works was combined with a perception that the orientation of the clerks of works to the building, as opposed to design, process may allow the main contractor leverage in their dealings with members of the design team. From the main

contractors' viewpoint relationships with the clerks of works were important to the extent that they were central figures in the running of the project on site (cf comments made in the MTS case). The point was also made that they offered the contractor representation for the 'building point of view'. The Site Agent on the PDL project, for instance, commented that: "you need an experienced clerk of works who understands building needs ... otherwise decisions take longer and (there's) more hassle". In describing the role he performed, the Clerk of Works on the same project emphasised that the job involved contributing towards the co-ordination of design and construction processes: "I'll tell the architect if I think his ideas aren't practical ... I can say 'Look, I can see what you're trying to do and appreciate it' - I can get inside the architect's head - ... but if I don't think it'll work I can say so ... ask him what he thinks (the main contractor) is going to say". The point here is that in occupying the middle position between the 'design' and 'construction' points of view a tension exists between an interpretation of the clerk's role based upon the need to translate (architectural) design ideas into construction practice - allowing for the feedback of the latter into the former; and an interpretation in which a latent conflict of interest between the parties to the contract informs expectations and views of how the performance of the role should be approached. In the NSS and AFU cases, for instance, the direct inference from the comments given by design team members was that the main contractor could not be trusted not to exploit the more tenuous link between designer and construction supervisor: in the NSS case the Clerks of Works had limited authority to issue instructions as a result. In both cases too, comments were made by the main contractors' staff to the effect that this allowed insufficient representation for the

'construction viewpoint'. In the MTS case, reference was made to the level of influence exerted by the Clerk of Works in the running of the job but without the authority to take decisions or issue instructions without prior approval. Taken together, these comments provide a classic illustration of the requirements put on an individual performing an 'integrator role' (Lorsch and Lawrence 1967b, Galbraith 1971) - whose positional authority is limited and whose input depends upon the use of expertise, persuasion and not a little tact and diplomacy. The difference for the clerk of works in building is that this bridging role crosses the boundary between organisational groupings - with all the implications for, and constraints upon, the performance of the role described above. What this suggests for the clerks of works themselves is their somewhat precarious position vis-a-vis the design team and main contractor. It suggests the potential for individuals occupying this position to be subject to conflicting demands from various directions, coupled with ambiguity arising from variation in the limits upon their direct influence from project to project. The effects of such dimensions were not directly investigated. However, it is clear from many of the accounts given in each of the four cases that the clerks of works operated at the centre of what were often milieux of conflicting and ambiguous perceptions, expectations and assumptions.

. Turning finally in this section to the question posed earlier concerning the extent to which an 'organic' structure of interaction was in evidence, the above discussion generally suggests a 'tension' between formal and informal patterns of interaction when account is taken of the contractual dimensions. The RAW project is a useful starting point for the discussion of the characteristics of inter-

organisational working relationships on site since it highlights, amongst other things, the tension between "business" and "technical" system (Sayles and Chandler 1971) considerations in the organisation and management of work. The description given in the case study chapter of the process of management on that project represents - as it does in the remaining four cases - only the most generalised account of the management process involved. A concentration on the more formal procedures for the approval of plans of work and upon the regular meetings held between clients' staff and main contractor and subcontractors, severely understates the observed direct dealings conducted between members of the respective teams and the extent to which informal, direct face-to-face contact and discussion of the details of the work on site coupled with ad hoc meetings involving various staff characterised working relationships. Space limitations in describing this and other cases, coupled with the impossibility of being fully able to record and chart the regularity and frequency of the direct contact that occurred on a daily or hourly basis, make this dimension impossible to quantify. However the comments made concerning, for instance, the close involvement of the AREs in checking design details, setting out and subcontractor performance, and the direct dealings of the Site Engineer and his staff with the AREs, supervising Clerks of Works and subcontractors' representatives perhaps give some flavour of the level of direct, lateral interaction occasioned in the supervision of the technical aspects of the work on site. However, despite the more 'organic' tendencies that this would tend to imply, it is important to stress the significance of the 'contractual dimension' underlying the relationship between the groups, and its existence as a counterpoint to the more informal and direct patterns of interaction between respective team members on site. The

early incident reported concerning the conflict that arose over design modifications discussed between the ARE, Sub-Agent and Site Engineer gives a greater insight into the processes involved and a useful illustration of the conflicting tendencies exhibited in the pattern of decision-making. What was remarkable about that incident was the manner in which the threshold was crossed between a more informal interactive approach and the adoption of a more formal stance on both sides. The incident was interpreted as the signalling of the limits to which substantive decisions would be reached without formal consent, and as such marked a movement towards the use of more formal procedural mechanisms to be employed where decisions that needed to be taken had a 'contractual dimension'. The reaction was of equal interest in that the threat of resorting to more formal procedures and, in particular, of 'escalating' the conflict was voiced. The incident and its potential ramifications are of some interest since they suggest the somewhat precarious balance between a flexible and informal working relationship that one would expect to be consistent with the requirements for the management of construction task work, and the more formal procedures consistent with meeting contractual rights and obligations in a legal context.

In other cases too, the conflicting tendencies were marked. The NSS case, for instance, stands as an illustration of the extent to which a more formal, contractual stance was adopted by both sides in response to a problematic situation. By the later stages of that project the position had been reached in which the level at which decisions were taken was effectively one step removed from the level at which the work on site was directly supervised and controlled. This 'escalation' appeared to be associated with the initial tendency

on the part of the supervising design team to delimit the extent to which staff involved directly in the job's supervision had the authority to reach decisions. The main contractor's response was to take the route referred to by the Site Agent in the RAW case, such that the state of affairs towards the end of the construction period was one in which the contractual 'battle lines' had been drawn between the participating organisations.

The PDL case - albeit a quite distinct set of circumstances - also offered an illustration of these conflicting tendencies in the management of project work. Here, it was the early stages that were marked by the tendency for some degree of caution to be exercised in dealings between the design team and main contractor with the consequence, suggested by the Clerk of Works, that it took a long time for the team as a whole to "gel" and for working relationships to reflect the degree of flexibility that was perceived as being one of the advantages of employing a 'neutral' main contractor in the first place. It was also noted that the effects of early problems in the design team - main contractor relationship spilled over into relationships with subcontractors on site. The General Foreman, for instance, referred to the continual necessity to "fend off" subcontractors wanting information and the need to "refer back" before making decisions on site, suggesting a limit to the extent to which decisions could be taken on the ground. More generally, the reference to subcontractors' reactions to this situation suggests a pattern of interaction in which the contractual dimension came to the fore. The perceptions of events described in connection with the later panel-fixing work gives a flavour of the change in attitudes that occurred - the subcontractor's representative describing the contrast between

the early 'accommodations' that were made and the subsequent tendency on the part of the design team to 'throw the book' at the firm. Again the inference is that a tension existed between conflicting expectations and assumptions of how working relationships would develop.

A more detailed discussion of the processes of problem-solving and decision-making in these respects will be returned to below. The comments made so far are not meant to over-emphasise the level of conflict that characterised inter-organisational working relationships during construction. Nor are they intended to de-emphasise the more 'organic' tendencies in the extant structure of roles and relationships within the project organisation as a whole and in the process of management on site. Rather the intention has been to emphasise the contradictory tendencies and tensions that appear to emerge when consideration is given to both operational and contractual dimensions in the management of work on site. In other words, the contractual dimension had a significant bearing upon the extent to which working relationships across organisational boundaries would exhibit characteristics of a more 'organic' interactive climate within the project team. Instances from three of the cases studied have been given to illustrate the tendency for interaction to be formal, more centralised, more hierarchical and based upon a more definitive recourse to the parties' own legal rights and obligations under the terms and conditions of contract in situations in which "business system" considerations become salient. What was particularly noticeable in the accounts reported across the case studies in this respect was the extent to which differential expectations and assumptions served to inform the parties' approaches towards the

management of the project. In the NSS and MTS cases, for instance, the view was made explicit that main contractors would be expected to avoid their contractual responsibilities to some extent in relation to specific aspects of the work. In the NSS case this appeared to result in the tendency for a tighter degree of centralised control to be exercised over the work to ensure that quality objectives were met. In the MTS case the belief that the contractor would tend not to check drawings (a tendency also reported by the ARE in the RAW case) was converted into the reported tendency for design staff to undertake the checking of drawings themselves (which the ARE in the RAW case also reported). More broadly in this case, a belief that the main contractor would try to avoid the responsibility for co-ordinating subcontractors' designs generated the tendency for members of the design team to actually become more directly and routinely involved in the process, thereby making the prophecy an almost self-fulfilled one. Perhaps the clearest instance of the impact of differential expectations and assumptions was that described in the PDL case. Here, early problems in the design team - main contractor relationship were felt to have resulted from the design team having specifically approached the job as a 'traditional' one in which the two were contractual adversaries - an approach which was felt to be inconsistent with the type of relationship needed for the 'management team concept' to operate effectively. More generally, these points suggest a level of mistrust, or at least caution, latent in the relationship stemming from the fact that the relationship is first and foremost a contractual one between separate parties. Whether the experiences on a particular contract would tend to reinforce such expectations (as in the RAW and NSS cases perhaps), or whether some other adjustment would be made (as in the PDL case)

would clearly be dependent upon the course of events on that particular contract. However the initial assumptions made form an important backdrop to the development of working relationships into the construction period. A more 'organic' interactive climate may be appropriate to the management of the work on site, or at least a preferred way of working to avoid delays in decision-making that may tend to be associated with a more formally enacted structure of management. However, the starting conditions for the development of such a 'climate' given a lack of familiarity and experience of working together, by no means guarantee that it will occur. On the contrary, it appears likely that the earlier stages in the development of the relationship would tend to be characterised rather more by caution in external dealings - a caution that may be dissipated as subsequent events unfold, but one which may equally well be reinforced given the salience of commercial objectives and the corresponding importance of the contractual dimension to the development of the relationship between the organisational subunits. The more general interpretation to be drawn from these descriptions (particularly given the situation described in the MTS case, where to some extent recourse to less formalised procedures and patterns of interaction led to the emergence of problems) is that it is not necessarily the case that 'business system' factors engender a more 'mechanistic', and therefore less effective, response to task circumstances. Rather that, given broad familiarity with technical and business system requirements due to extensive experience of performing broadly similar types of construction task (in contrast, say, to circumstances on the NASA, or similar types of, projects), it is the particularistic relationship between the sets of assumptions and expectations made concerning the parties' responsibilities with respect to any given task that proves

to be the critical set of factors. In other words, it may well be that a less "effective" system in construction operates on 'mechanistic' lines, other things being equal. However, a situation in which a more 'mechanistic' interpretation of roles, relationships and procedures is confounded by differential expectations and assumptions may prove more highly problematic.

The previous section has looked at characteristics of the structure of interaction between the parties to the contract across the cases, paying particular attention to the relationship between the formal structure of interaction as defined by the set of contract terms and conditions employed, and the more informal and extant patterns of working relationships engendered by the approaches taken towards the management of the construction project. The aim has been to demonstrate the conflicting tendencies and tensions present in an orientation towards the requirements for managing the task on the one hand, and an orientation towards the contractual dimension or "business system" on the other. The aim of this section is to conclude a comparison and contrast of the cases by focusing upon the processes this situation gave rise to across the cases. Incorporated into this analysis will be features identified in the earlier discussions in Chapter 1) concerning the nature of the work, the relationship between project goals and organisational goals, the more general pattern of relationships between and within each participating organisation, and factors relevant in the 'pre-history' of each of the projects studied.

The first salient feature to be addressed relates back to the earlier discussion of the broad distinction drawn within the sample of cases between the two 'recurrent' projects (the RAW and AFU) and the remaining three laboratory cases (the MTS, NSS and PDL). In these latter cases, what was most clearly at issue in the accounts reported was the problematic of the relationship between design and construction. This was manifested in the accounts given reporting difficulties experienced in ensuring a flow of design information between the

parties, uncovering 'snags', accommodating variations in the design and so on. The issue was complicated further by the intensity of services work involved on each of the three projects: a further problematic occurred in the relationship between architectural and engineering services design and construction. These three cases were ones in which the work involved was distinct, complex and fragmented. The design for the work in each case was also to some extent (and in relation to various aspects of the work) incomplete and subject to variation in detail as the work on site progressed. In the RAW and AFU cases, in contrast, the work involved was similar in type and scope to earlier (and future) projects, somewhat less complex and fragmented. The design for the work in each case was largely, if not fully, complete by the time work started on site, and few variations - and none of those 'major' - occurred in the design as work on site progressed. There was, as a consequence, a more definite delineation of the design and construction stages of the project.

In each of the three laboratory cases, significant problems were described in achieving a sufficient level of co-ordination of design and construction processes: in the MTS case, these problems centred mainly around the co-ordination of M & E designs and the physical integration of these services with the main building construction; in the NSS case the problems reported centred mainly upon the finishing and landscaping work; in the PDL case, the early problems were identified as occurring mainly in relation to the main structural work on the building - although the 'tightness' of the programme as a whole was seen to put a good deal of pressure upon the co-ordination of design and construction processes across the range of types of work undertaken throughout the period of construction. This is not

to suggest that the problems reported necessarily had any impact upon achieving the performance levels specified in the contract (eg in the PDL case, it was agreed that time, cost and quality objectives had essentially been met). Rather that the comments were directed towards the way in which those objectives had been achieved. As a general observation, many of those interviewed referred to the general problem associated with managing the two-way flow of design information between the parties in the context of a contractual relationship. From the main contractor's viewpoint, difficulties in obtaining definitive design information caused problems in the advance planning of work to allow for offsite planning and production 'lead times', while the level of design detailing sought (eg tolerances) often did not allow for the practicalities involved in on-site construction. From the designer's viewpoint, builders were too ready to insist on 'unrealistic' target dates for the receipt of fully detailed design information; the problem on site was to ensure that the design was built to the details included in the specification and working drawings. For the main contractor the issue was one of being able to plan the work effectively in advance; for the design team the issue was one of being able to control effectively the quality of finished work and of supplied components. It was this interdependence between product design and production planning that was at the centre of many of the comments made concerning the problems that tended to arise in the relationship between designers and builders in general.

An important point to re-emphasise concerning the use of (often retrospective) accounts given by those interviewed from each side of the contractual divide - and one that also figures as an analytic point in itself - concerns the level of 'blame-placing' (Sayles and

Chandler 1971) in many of the accounts given. Not surprisingly, each party directed attention towards the problems it had faced that had been 'caused' by the other. The accounts given in each of the case descriptions have attempted to explore particular issues through a reliance upon corroborative evidence and, to a lesser extent, direct observation, while simultaneously allowing for the differential perceptions that often marked the interpretation of particular issues.

Attention has been directed towards the nature of the work involved and the design for the work, since they emerge in the case descriptions as important conditioning influences upon the characteristics of interaction between the parties. In the RAW and AFU cases, where the work involved was relatively more standard and routine and the design to all intents and purposes complete and 'static', the outcomes of the strategies adopted by each party to achieve their objectives reflected the extent to which the objectives of work on the project were perceived as being fixed and definitive. In the RAW case in particular, reference was made to the divergence of opinion between the client's staff and main contractor's staff - embodied in the approaches taken by the respective two senior representatives on site - concerning the extent to which the design for the works allowed scope for bargaining between the parties concerning some of the methods and materials specified for use in the contract. To the SRE, the main contractor "wheeling and dealing" or "taking liberties" with respect to the contract was out of the question, and the full specification of the works allowed no scope for negotiation; to the Site Agent, this was interpreted as 'inflexibility' or "going by the book". The point here is that the 'book' was one that was sufficiently detailed and complete, and the contractual position sufficiently definitive

to allow the client's agent to withstand any attempts made by the main contractor to induce changes in it. In this case, what was interpreted as a conflict of interests between the parties stemming particularly from the contractor's attempts to achieve a profit, (or avoid a loss on an underpriced job) at a time of acute financial difficulties, appeared to manifest itself in the form of a personal contest between the two senior representatives on site. Attempts by the main contractor to employ bargaining strategies in the relationship with the client's team were met with the clear signal that there was in fact no scope for bargaining over substantive issues and, further, that perceived efforts to employ unacceptable procedural mechanisms to effect a change in the 'agenda' would not be countenanced. In other words, the situation was one in which the early stages were marked by the adoption of two competing strategies - on the one hand, attempts to introduce a degree of bargaining into problem-solving and decisional processes; on the other, an expressed adherence to the full terms and conditions of the contract and the formal rights and obligations of the parties involved under the form of contract. It was the legitimacy afforded through the contract to the Resident Engineer's right to exercise discretion in accepting or agreeing changes to the work that formed the backdrop to how circumstances developed: the SRE's interpretation was that proposed changes to the work could not and would not be accepted, and that the main contractor's efforts to secure changes to benefit their own interests were not acceptable. It was the choice to stick closely to the substantive content of the agreement and to interpret the limits to the discretion available to him to make decisions as being tightly constrained that appeared to form the SRE's approach to the management of the project. The Site Agent's interpretation, in contrast, appeared to be that there

was more flexibility available and that the process then involved argument, persuasion and bargaining in some instances to elicit changes favourable to the company.

In the AFU case, much less detail was given of the characteristics of the relationship between the parties in terms of the processes of problem-solving and decision-making. The type and level of disagreement between the parties described in the RAW case, was not at all apparent in the AFU case. Instead the main inter-organisational relationship was characterised as being largely free of elements of conflict or disagreement between the parties, and few references were made towards the emergence of issues in which bargaining or negotiation, or attempts to employ these strategies, emerged. The discussion in the previous section reported a tendency towards caution in external dealings - manifested in views and opinions expressed concerning the potential vulnerability of clerks of works. However, these were general comments, and no direct indication was given that such circumstances were specifically relevant to an understanding of events on this case.

What is interesting in comparing these cases is the particular constellations of factors which influenced the parties' motivation and ability to engage in strategies aimed at securing some advantage with respect to the achievement of organisational goals. In the RAW case, the financial situation facing the firm in general - and specifically on this project (to the extent that it was underpriced) - underpinned the motivation to attempt to secure changes which would be favourable to the main contractor. However, the ability to pursue such a strategy was limited simply by virtue of the lack of scope

available, and also by the lack of acceptance on the part of the client's team of the validity of such strategies. In the AFU case, there was no evidence to suggest that the main contractor had the motivation to make such moves. Indeed, in the context of a longer-term relationship with the Development Corporation as client (and thus with the design team), such moves may more likely have been counter-productive in the long term. Moreover, the scope for doing so was limited given the more straightforward nature of the work, and the completeness and clarity of the design in relation to it. However the case did also provide evidence of the potential ability for the main contractor to pursue more manipulative strategies. In particular, the perceived conflicts and tensions within the client's design organisation were interpreted in part in terms of the relative 'advantages' or 'disadvantages' they offered to the main contractor. While problems in the hierarchical chain of command were viewed as being wholly an 'internal thing', they were externally 'visible' and engendered a cautious approach towards dealings with the client's team with the aim of 'not rocking the boat'. The early reported problems among members of the design team, in contrast, appeared to offer the main contractor some leverage in their external dealings and an ability to play off one party against the other. Too much should not be read into this situation since the instances referred to occurred at a very early stage, and the discussion was based upon entirely retrospective accounts from only one party's perspective (ie the main contractor). However, the comments do suggest the perceived opportunities available stemming from a more fragmented pattern of control exercised over the total design and construction process described in earlier sections of Chapter 11. In contrast, the RAW case has been interpreted as one in which control over the construction

process was much more unitary, direct and centralised. As such the inability of the main contractor to effect outcomes more consistent with the achievement of their own (financial) goals, was not only conditioned by the lack of scope available and by the client's representative's interpretation of the illegitimacy of attempted negotiating strategies, but also by conditions related to the pattern of control exercised in the running of the project. Put more simply, it was the lack of power of the main contracting organisation coupled with the power and lack of vulnerability of the client's representative's position in the RAW case, that combined to make unsuccessful the strategies that were motivated by a concern with achieving a more satisfactory financial outcome for the main contractor on the project. In the AFU case, the suggestion is that the ability of the main contractor to influence directly their own outcomes was there to the extent that internal differences within the design team allowed them opportunities. However, the scope for doing so was similarly limited, and, more importantly, there was no real positive motivation to do so. On the contrary, unsubtle attempts to pursue direct strategies aimed at improving their outcomes, may have jeopardised a working relationship which on the whole was considered to be 'good'. In a sense the general impression that comes through from the RAW case is that there was 'little to be lost and much to be gained' in attempting to 'take on' the representatives of an important, but possibly only one time, client in circumstances in which the firm was in financial difficulties and had obtained the contract by under-pricing the job in the first place.

In the three laboratory cases in the sample, circumstances were such as to create a somewhat more complex picture of the strategies

and tactics adopted. In all three cases the work was complex, distinct and variegated, and the design and specification to some extent open to fuller interpretation during the course of construction. Taking the two smaller cases first (the MTS and NSS), there were very real differences in the outcomes that were perceived to have been achieved for each of the main parties concerned. In the MTS case, the accounts given suggest that the process of achieving objectives on the project had not been unproblematic, but that the outcomes achieved had nevertheless in the end proved satisfactory to both main parties. In the NSS case, the accounts given reflect more clearly both a problematic process and a level of dissatisfaction with the outcomes achieved on the project. Comparing the two cases with the factors described in the RAW and AFU cases, it is interesting to note how differential patterns of control between the two design teams, coupled with differences in the position of the two main contractors with respect to the client organisation and project goals combined to affect the nature of the relationship between the parties in each case.

In the NSS case, the substantive issue over which the parties disagreed related to problems experienced in the production of a detailed design for the later landscaping and finishing work. The broader issue, of which this was viewed as being symptomatic, was the (in)compatibility of the cost and quality objectives pursued on the project. The parties held conflicting assumptions concerning the extent to which the construction of a high quality, 'prestigious' building was compatible with the funds budgeted for the work. From the designers' viewpoint the aims were compatible and not contradictory, given that the main contractor had submitted a price for the job that had been accepted. The achievement of project objectives was

then predicated upon maintaining effective control over the quality of work produced on site. From the main contractor's viewpoint, the aims were contradictory, given that the quality objectives the designers sought to achieve following from an initially incomplete design were incompatible with the amount initially budgeted for the work. In other words, there was a clear conflict of interest between the parties that stemmed from the inter-relationship between financial and quality objectives pursued on the project: the design teams' goals could only be fully achieved at the expense of some direct loss to the main contractor (and/or the subcontractors employed): the main contractor's goals could only be fully achieved if the design team were to compromise on the quality standards they set and maintained.

In the event, it appears that the balance of power in this situation, and the resultant outcomes, tilted more heavily in favour of the design team than of the main contractor. Reference was made to the extent to which problems were 'escalated' to higher levels within the respective organisations, and the comment was noted that the situation had developed such that the main contractor and subcontractors had "united to fight the common foe". As such the picture is one almost of a battle fought between the client's agents on the one hand, and the building team on the other. However, the course of the 'battle' as such was influenced by broader factors related to the natures of the organisations involved and features of the relationship between them. In the first place, the contractually stronger position of the client's representatives as arbiters of decisions reached concerning the adequacy of performance levels achieved on the project, meant that they were in the position of being able, under the contract, to decide whether to accept or reject

materials, components or work on the basis of the quality standards achieved. In a way the situation appeared close to that found on the RAW project, in which the senior representative was able to insist upon the main contractor producing to a level consistent with what was specified in the contract. The difference in the NSS case was that that 'level' was to some extent ambiguous: the lack of a fully detailed design coupled with continuing uncertainty over details of the work (in the later stages in particular) left open the interpretation of the standards to be achieved with respect to the 'quality' of the building; the performance parameters in this respect were only really firmly established as the work on site progressed, and, moreover, were also at the discretion of the designer. While differential interpretations were drawn over the nature of the substantive content of the agreement, it was the client's agents who were vested with the contractual authority to pursue their interpretation. The main contractor's response to this was noted in the comments made concerning the tendency to respond 'contractually' to delays in the receipt of information and also in the attempts to take their argument and case to a higher level within the design organisation. These more aggressive tactics appeared as a response to the perceived difficulties in conducting relations with the client's team in a less official and more informal way.

. Looking at other factors influencing this outcome, there was a fairly clear recognition of the impact of characteristics of the relationship at a broader, organisational level. The situation was one in which the main contractor was undertaking work for a client upon which they had a continuing longer-term dependence by virtue of the importance of the client within the locality for firms the size of

Steelframe. The project was not only of importance in itself - in relation to the firm's annual turnover - it was also important in that it represented one of a series of projects undertaken for the contractor's main client. Furthermore, there were direct potential pay-offs in that success on this project might enhance the possibility of achieving further work in the second stage development. (Ironically, the company's Surveyor reported before the submission of the tender for this work that their "experience" on stage one had enabled the firm to fully account for the likely difficulties to be encountered in stage two: having done so, the tender was rejected as being too high.) The point here is that the company was one that was highly dependent upon the local authority as client, and consequently in a weak position vis-a-vis the client's in-house design team. A related factor was the actual size of the firm: it will be recalled that reference was made to the financial vulnerability of the firm and the 'opportunity cost' of resources tied down on any one project; reference was also made to the disadvantages faced by the firm in not possessing a full legal capacity to respond to 'contractual' problems.

At the same time, reference was also made to the vulnerability of the client's in house design organisation: the project was significant in scale and 'prestigious' from the point of view of the type of work involved. It was also important in that it offered the possibility for the design team to obtain further work from a new and important client in a situation in which the department's capacity to handle new projects was being eroded in the longer-term. The importance of the project in these respects was given explicit attention by members of the design team interviewed, although it was only staff from the main contracting organisation who explicitly referred

to the impact upon working relationships on the project of factors associated directly with this internal 'political' context. The interpretation made was that the nature and perception of the objectives to be achieved on the project were largely conditioned by the complex of factors associated with this internal backdrop. In other words, that the peculiarities of this situation forced members of the client's team into a position in which success on the project was effectively made contingent upon the reconciliation of a set of somewhat contradictory objectives. On the one hand these broader aims could be achieved by emphasising quality objectives; on the other, the designers were faced with fairly stringent controls on capital expenditure on the project. The response to this dilemma appeared to be in the more direct and centralised control exerted over the construction process to ensure quality control, coupled with a more explicit articulation of the main (and sub-) contractors' responsibilities to achieve the performance levels that would then be set by the design team as the work progressed. It was the dependence of the main contractor (and local subcontractors) upon the client that then determined the extent to which such a strategy could be successfully pursued.

Two further features of this scenario need to be mentioned. Firstly, it was interesting to note that the main contractor coupled a perceived "interference" in the job's running with a level of "indecisiveness" or "uncertainty" in the process of reaching decisions. While it is perhaps inferring too much, such comments do point to the likely manifestations of a situation in which members of the client's team were faced with conflicting sets of expectations regarding the objectives to be pursued. As noted in the case

commentary, it was the architectural Project Manager - who was explicitly held accountable for fully achieving project time, cost and quality objectives - who was at the centre of this milieu of conflicting expectations. The comments reported concerning direct control, "interference" and "indecisiveness" do not appear inconsistent with the likely response to a situation in which some level of role conflict occurred. Secondly, the situation was one in which the internal structure of the design organisation lay the basis for the exercise of more complete and direct influence over the course of events on that project. The level of involvement and influence of senior architectural staff in the project was considered greater than normal due to the importance of the project. However, this reflected no change from previous projects in the structure of authority within the in house design team. Rather it reflected the tendency for authority not to be delegated in this case due to the factors outlined above. The more direct and less fragmented pattern of control exercised over members of the client's in house team by senior architectural staff, made for a much more hierarchical within-team structure than that found in either the AFU or the remaining two laboratory cases (in which the Project Manager performed more of a co-ordinating role within a client's team composed of specialists seconded from separate departments). The reported tendency for team members being in a position of having to 'cover' themselves and 'refer back' for decisions provides a suggestion of the implications of this situation. In this respect, the situation perhaps compared more closely with that found in the RAW case than with circumstances in the other architectural cases. The major difference in the NSS case - and one whose implications for the level of control exercised was noted in the accounts given by the architectural staff - was in

the employment of M & E consultants. Here, such a level of direct control and influence over members of the client's team was less apparent as evidenced in the accounts given of problems experienced in the relationship with the mechanical firm. But in terms of external dealings between the client's team and main contractor, the situation was one (excepting the position of the consultants) in which a 'united front' could be presented. The general tenor of the comments given concerning the high degree of centralised control, the lack of discretion of the Job Architect, Surveyor and Clerk of Works, and so on, suggest that the ability to pursue the architectural case (and to withstand counter-strategies adopted by the main contractor) was not impeded by structural conditions within the in house design organisation.

The same was not the case in the MTS project. Here, the main focus of attention was precisely upon the difficulties that were felt to have emerged due to the structure of roles and relationships within the in house design organisation. Reference has already been made in the previous section to the extent to which internal conditions engendered or enhanced differential and divergent orientations towards project work. The significant feature for this discussion was reflected in the reported tendency for inter-departmental relationships (specifically with the M & E section) to involve some level of negotiation in decision-making. The position appeared similar to that described in the AFU case in that staff from the central architectural department were dependent upon contributions to the design and management of the project from senior staff seconded from other departments or sections within the overall design organisation. The difference in the MTS case, and the backdrop to

many of the comments made in this respect, was the somewhat more limited direct influence of architectural staff, particularly given the secondment practices adopted within the division as a whole. It was the greater perceived gap in 'communication' between design team members and the attendant difficulties in co-ordinating work within the team which formed the important underlying factor in the flow of events in the MTS case.

What was particularly interesting about the MTS case, was that the problems that were reported also occurred in the context of disagreement over the rights and obligations of the respective parties to the contract. As such the issues raised pointed to a degree of expressed 'structural', as much as 'operating', conflict (Molnar and Rogers 1979) - or a divergence of views on the terms and conditions of the contractual relationship itself. It was not that the parties necessarily differed in their orientation towards the objectives set for the work, but that the parties differed in their orientation towards the procedural mechanisms employed to achieve those objectives. From the designer's viewpoint, the approach adopted was simultaneously informed by their position under the formal terms and conditions of contract, and also by the expectation that in practice they would have to become more closely involved in the management of the design process to the extent that the main contractor would attempt to avoid their formal responsibilities. From the main contractor's viewpoint, the approach adopted was simultaneously informed by a need to exercise control over this process (particularly in the architectural sphere), and also by a reluctance to accept the validity of the conditions that placed the onus upon them to assume full responsibility (in the M & E sphere) for the co-ordination of

subcontractors' designs. The ambiguities and conflicts latent in this milieu of divergent assumptions, perceptions and expectations were given some attention in the previous section. What is relevant to note here is that such conditions did not lead to an 'escalation' of conflict in the same way that happened on the NSS project. In the MTS case, there was a sense in which the fractionalism and lack of fully centralised control within the design team coupled with the tendency to depart from the more formally prescribed patterns of interaction served to counteract the impact of these factors upon the interorganisational relationship. Added to this were the strategies employed by the main contractor to prevent a similar situation arising as had arisen in the previous project. Given the positions of the respective organisations under the form of contract, and the power imbalance at an organisational level, one might have expected the outcome to have been somewhat different from that reported in terms of the impact upon the goals of the main contracting organisation in particular. In other words, the potential vulnerability of the main contractor was offset by a combination of strategies pursued to ease expected difficulties, and by the vulnerability of the design organisation itself due to internal divisions and lack of cohesion. The examples given in the case study chapter provide useful illustrations of this. In the case of the windows subcontract, the main contractor was able to fall back on their contractual position of having to be informed of design detail alterations, and hence avoid the responsibility for the impact of changes that had occurred in direct dealings between the architect and subcontractor. In taking up the initiative in becoming more directly and more intensely involved in the continuing design process, the architect was taking some risk in departing from the formal procedures. The outcome was the

subsequent argument that arose between architect and subcontractor concerning the responsibility for delays to the work. The delay was not critical and had not affected the main contractor's plans for overall completion. This is not to suggest that the delay did not cause problems. Rather that the liability for it lay elsewhere and not with the main contractor. In the case of the M & E work, it was the similar tendency for M & E members of the design team to become directly embroiled in dealings with subcontractors, coupled with the lack of full direct influence and control over the M & E process that were the underlying factors. It is suggested here that the design team was in some disarray. In such a situation it is quite easy to see how their position may then have been weakened with respect to external dealings with the main contractor. To the extent that the issue concerned the integration of architectural and services designs per se, rather than being directly concerned with the translation of designs into construction, then the main contractor could avoid liability for changes that had implications for the construction of the work on site. The more general point is that so long as the main contractor was 'covered' - and this is where the main contractor's response came in - then it was in the extent to which problems that occurred were located and locatable in relationships amongst the design team and with subcontractors that a 'let out' was available. This is not to suggest either that this gave rise to few problems as perceived by the main contractor's staff, or that there was any positive incentive to attempt to exacerbate the situation. Rather that in pursuing the aim of 'winning back' confidence in their ability to perform work for an important client, the approach was to contain and control the situation as much as possible in a way that mitigated against the knock-on effects of an expected (and actual) level of

dissociation between the main building and M & E design and construction processes. It was the pattern of dynamics of internal relationships amongst members of the design team and their relationships with subcontractors that formed the crucial dimension in this respect. The aim of the main contractor was to avoid potential difficulties having a direct bearing upon their own performance. A broad overview of the descriptions of performance and events on the MTS case would seem to suggest that in this they were largely successful.

The PDL case has been left till last to discuss due to the distinctive characteristics associated with it being run as a management contract. The previous four cases have focused upon the nature of the interorganisational relationship at the point of contact between design team and main contractor. In doing so a central component has been taken as being the position of each main party as defined by the commercial exchange relationship between the parties. The PDL case was very different in that the contractual neutrality of the main contractor was the point that was stressed. The implications of this situation with regard to the 'role' performed by the main contractor within the project organisation as a whole were given some attention in the previous section. The aim of this section is to provide an overview of events on the project as with the four other cases, but with special regard for this basic difference in the administrative set-up.

What was particularly noticeable in the PDL case was the manner in which the combination of circumstances found on the project led to a situation in which collusive and coalitional strategies between

members of the 'management team' came to the fore. This point was most directly expressed by the M & E consultant towards the end of the project: in comparing what happened on the PDL project with what he felt would have occurred in a more 'normal' situation, he clearly expressed the opinion that circumstances on this project would ordinarily have given the contractor a "field day". Instead, the situation had been reached in which, despite the earlier problems, the relationship between the design team and main contractor had developed well. This was to such an extent that he himself was effectively outmanoeuvred at the very end of the construction period in the face of the architect and main contractor tacitly colluding to avoid any potential threat to completing the work on time (the issue being that the time available for commissioning the M & E work had by then been 'squeezed'; the Clerk of Works was in a similar position in the time left available for 'snagging'). In the early stages, conflicting approaches to the management of the project had created a tension in the relationship between the in house design team and main contractor. Yet even at that point counteracting tendencies were found in the 'behind the scene' deals with the main frame subcontractor in which the main contractor and PQS collaborated. Similar tendencies were later found in events reported on the subcontracted panel package, from which the interpretation was drawn that the main contractor pursued a variety of strategies (directly expediting the work, negotiating down claims, etc) that they were not formally required to (since their expected role was more one of acting as a 'mediator' in design team/subcontractor dealings), but which were undertaken to accommodate the conflicting pressures inherent in the constellation of objectives for the work - and in particular to contain the effects of problems experienced in the

continuing design process.

The key to an understanding of such events on this case was in the development of a (tacit or explicit) understanding of the mutual dependency of each of the main parties upon the client. For the designers, the project was of some strategic importance, and performance on it thereby critical. Similarly for the main contractor. Both parties were faced with the opportunity of securing future orders in what effectively constituted a 'new market' (the main contractor anxious to add another important client to its 'list'; the design team anxious to have future large, industrial projects undertaken in house). As suggested in the earlier discussion, in this sense the project was a 'test case'. The early problems surrounded the fact that given their positions, the parties were then faced with one another perceiving that the stance taken by the other was not one that was consistent with achieving these aims in a situation in which the objectives set for the work created significant pressures. From the design team's point of view, the main contractor was not adopting a firm enough line in controlling the work on site and in representing the client's interests; from the main contractor's point of view, the design team were not attuned to the 'team concept' and were unwilling to accept the implications of their orientation towards the continuing design process. By the end of the construction period some level of compromise appeared to have been reached, and the objective of completing the work on time came to the fore - acting as a unifying influence and focus for collective attention and effort. In between times, and if the events reported on the subcontractor panel package are anything to go by, the process had involved the main contractor in tactical moves to dissipate the pressures stemming from time, cost

and quality objectives. In part this had involved them directly expediting the work. However, given the position of the main contractor as part of the 'management team', the inference is also that the pressure was also to some extent diverted away from the 'management team' and towards the subcontractors performing the work. In other words the main contractor moved from an initial stance of 'neutrality' to aligning themselves more fully with the interests pursued by members of the client's team. At the same time, in changing the state of the relationship from an 'adversarial' one to a 'collaborative' one, the main contractor relied upon the development and maintenance of collaborative relationships with 'allies' amongst the client's team (specifically the PQS) whose dependence upon the client was also a significant feature, and whose orientation towards the management of the project was more closely matched with theirs. The fact that the client's team consisted of a 'core' of in house architectural and (structural) engineering staff with 'satellite' consultancies (the PQS, M & E) made the task of arguing the case that much easier, since there was scope for 'detaching' members of the team and forming a 'united front' based on specific issues. The fact that in the early stages such moves were clandestine was symptomatic of the early lack of cohesion of the 'management team'.

. To sum up this section, before moving on to a discussion of the implications of the case data and inter-case analysis for theory and research into complex organisations, it is useful to provide a brief overview of the salient conditioning influences upon the conduct of inter-organisational working relationships. Broadly speaking, the discussion has focused upon the importance of four sets

of factors to an understanding of events on each project: the nature of the work, its objectives, and relationship between design and construction processes; formal remits and structures of interaction associated with the terms and conditions of contract; internal structures and processes of interaction and their impact upon external dealings; and the broader patterns of power and dependency at an organisational level that informed approaches adopted at an operational level. The discussion has centred upon the manner in which these factors affected the parties' motivation and ability to pursue strategies aimed at achieving preferred outcomes and in dealing with pressure and/or resistance in external dealings. The picture that emerges is complex due to the variety of factors that are subsumed under the categories, and the particular configuration of associated factors in each case. However some general patterns do emerge from the analysis. In particular, the combination of a clear operating and structural remit, a more unitary and cohesive subunit structure and the economic dependence of the main contractor on the client organisation served to promote conditions in which the vulnerability of the client's team was lessened and their influence in the management of the work heightened. Conversely, and given the motivation to engage in goal-directed strategies, the ability of the main contractor to do so was heightened by operating and structural uncertainties or ambiguities, divisions within the client's team, and a less critical dependence upon that individual project and client. These sets of conditions and their effects upon the nature and development of working relationships between the parties were most clearly manifested in the RAW case. Here the client's representative was fully able to withstand attempts made by the main contractor to pursue strategies that were geared towards fulfillment of their own

aims on the project. The combination of a clear and definitive design and specification for the work; a form of contract that lent itself to few ambiguities concerning the discretionary authority available to the client's representatives and their obligations in this case; a pattern of internal control that was both unitary in nature and centralised; the lack of potential anxieties stemming from the 'criticality' or strategic importance of the project to members of the client's team; and the importance of this project to the main contractor (ergo their dependence upon the client) - all these factors served to consolidate and reinforce the position of the client's team in interaction and to weaken the main contractor's. Added to the latter's problems were the financial vulnerability of the company at the time, and a basic lack of internal cohesion within the operational subunit. Towards the other extreme was the MTS case. Here, design problems and ambiguities latent in the contractual arrangement for dealing with such issues coupled with a fragmentation of control within the client's team served to weaken the client's team's position. This would otherwise have been stronger given their contractual authority, the influence accorded by the sheer economic power of the client organisation as the major public sector client, and the lack of any indication that the project was critical in having some strategic importance for the design team (as was the case in the NSS and PDL projects). Between these two were located the three other cases, although the range of dimensions involved does not allow for an attempt to 'locate' them. On the one hand the NSS case was closer to the RAW case to the extent that a more unitary and centralised pattern of internal control within the client's team was an important feature. The configuration of relationships in the AFU case suggest some similarity in this respect to circumstances in

the MTS case. Furthermore there were very basic differences in the degree of dependence of the main contractor on that particular client, and the criticality of the project to the achievement of organisational goals that suggest a similar tendency in the 'location' of the projects along this 'continuum'. On the other hand, differences in the clarity of the design and operational remit and the implications of this for the contractual authority of one party over another, coupled with differences in the extent to which the projects assumed some critical strategic importance for the respective clients' teams suggest the reverse was the case. For the PDL project the circumstances suggest a fairly close comparison with the MTS case in many respects. The essential difference here lay in the specific nature of the contractual arrangement employed and its implications in a situation in which mutual dependency and fragmentation in control on both sides of the contractual divide (here referring also to the position of the main contractor vis-a-vis nominated subcontractors) were critical components. What is being indicated here is the dialectical relationships amongst the dimensions taken into account in the analysis. Separating these out to look at the influence of particular factors ceteris paribus does throw up some significant points. In particular that the tendencies noted towards matrix management within the client's team tended to weaken their position in external dealings with the contractor's team (compare, for instance, the AFU, MTS and PDL cases with the RAW and NSS cases. In the NSS case reference was also made to a within-case distinction in this respect associated with the internal situation on the one hand and the employment of consultants on the other). However, it is the particular constellations of these factors and their inter-relationships that provide the basis for a fuller understanding of the dynamics of the working relationship

between the organisations involved in each of the five cases investigated.

CHAPTER THIRTEEN

DISCUSSION

13.1 Summary of the Main Findings

The main set of findings to emerge from this study can be summarised briefly as follows. In the situations encountered across the five case studies (and bearing in mind important within-case variability), there appeared to be some level of inconsistency between the more 'flexible' forms and processes of interaction that were deemed appropriate given the levels of complexity, uncertainty and interdependence in the nature of the work being undertaken on the one hand; and the actual more structured and 'rigid' forms and processes of interaction that tended to occur, and stem from the importance of the relationship as an essentially contractual one, on the other. While on the one hand, a generally more 'flexible' organic system of management was seen as important, and indeed in many respects did occur, in practice limits to a desired level of 'flexibility' and informality in interaction arose that stemmed from the fact that the parties' approaches were guided and informed, above all, by their contractual relationships with one another.

The 'rigidities' that occurred in interaction as a consequence appeared to emerge as relatively more problematic issues in the three more complex and 'non-routine' projects in the sample. More specifically, they tended to emerge as a corollary to the close and continued interdependence between ongoing design and construction

processes. The types of problems that were referred to included perceptions that decisions were taken too centrally, views and opinions were not fully taken into account, interaction was too formally conducted, and hierarchical rather than network interaction was prevalent. Similar tendencies on the more 'routine' projects, though apparent to a similar degree, had by no means the same salience attached to them as problems in the management of the work on site.

Paradoxically, those former situations should have been those in which one would have expected the heightened efficacy of a more 'flexible' approach, given the nature of the 'technical system' and the uncertainties and interdependencies inherent in the ongoing relationship between design and construction. However, given the organisational (and corresponding contractual) divide, it was precisely in those types of situations that such an approach proved to be less likely. Indeed, some of the evidence suggests that attempts to adopt this approach in such conditions may have served only to enhance the parties' contractual vulnerability in interaction. The more likely response would tend to be the more cautious and guarded approach engendered by the salience attached to contractual or 'business system' considerations.

These 'business system' pressures appeared to place a strain too upon the mechanisms employed to achieve integration within the project organisation as a whole. In most of the cases, more informal patterns of direct lateral interaction formed the main means by which a degree of collaboration could be achieved. The problem was that in those cases, the limits to the efficacy of

direct lateral interaction as a means of achieving a degree of integration emerged quickly once issues emerged with a 'contractual implication'. The more formal framework established in the terms and conditions of the contract then served as the baseline against which relationships were conducted. In the only case in which a main managing contractor was appointed to explicitly contribute towards achieving a sufficient level of integration, their ability to do so was constrained by the importance of the contractual arrangement in guiding and informing the parties' stances in interaction. Again, on the less 'routine' projects, the difficulties associated with co-ordinating work, particularly insofar as ongoing design issues were involved, appeared to be particularly problematic. However across the cases, there was some difficulty in achieving a sufficient degree of integration between organisational subgroupings across the design-construct divide to the extent that the parties' positions were informed by a degree of caution and suspicion or mistrust of the others' motives.

On the basis of the data that has described circumstances and events across the five projects, it seems possible to conclude that it may tend to be only in specific sets of circumstances that one might expect the approach actually adopted to be compatible with the requirements set by the nature of the task. Firstly, where the task being performed was comparatively straightforward and 'routine', and where there was a relatively clear separation between design and construction processes. In such conditions, the types of problems that emerge would tend to have less 'contractual importance' attached to them. Whereas working

relationships may still tend to be conducted more formally, reflecting a degree of caution, this would less likely be with any particular adverse effects on the running of the job. In other words, the more 'mechanistic' tendencies implied here, and which were observed to some extent across all the cases, would tend to be suitable given a more 'routine' task and fewer uncertainties stemming from the interrelationship between design and construction processes. The evident irony here is that the greater these uncertainties in a situation of a more complex and interdependent set of construction processes, the more likely it is that efforts are made to tighten up procedures and conduct interaction more formally in the face of the potential contractual 'threat' that they imply. Consequently, assuming some degree of latent mistrust in the relationship, the more likely that an inappropriate 'mechanistic' system of interaction in conditions of task uncertainty will emerge.

This picture is complicated further, when one looks in more detail at the sets of factors as they combined to produce a context within which the latter alternative occurred, or influenced its development as the relationship progressed. Across the cases, there was sufficient evidence to suggest that this degree of latent mistrust was an important premise in interaction and a factor that engendered generally a more cautious, guarded approach. However, given this baseline premise, two broader sets of factors served to account for the direction that events in each case would take. Firstly, it appeared that, in order for an appropriate degree of collaboration (rather than conflict or competition) to emerge

in the relationship, the parties either would have no positive and direct motivation to affect the course of decision-making in pursuance of their own interests at the expense of the other; or that, despite a latent incompatibility of goals and interests, the parties would have sufficient positive motivation not to attempt such strategies. Here, the more critical was the project to organisational fortunes, and the more 'disadvantaged' felt one party with respect to the other, then the more likely that a 'vicious circle' in interaction would emerge.

Secondly, the course of events was notably affected by the comparative ability of each party to pursue such strategies. Here, the formal position power of the participants under the contract, informal patterns of power and dependence between the organisations concerned at a wider level, and the internal context of their involvement on the project, combined in a variety of ways in each case to affect the capacity on the part of one party vis-a-vis another to pursue their own strategies, or to resist those strategies pursued by the other. What were particularly noticeable in this respect were two main features. Firstly, part of the ability to affect outcomes was contingent, other things being equal, upon the scope afforded to the participants, given a degree of lack of clarity or full coverage in both the substantive and procedural aspects of the contractual agreement. In other words, the greater the uncertainties or ambiguities in the task remit and/or in the formal structure that defined the parties' roles and responsibilities in the management of the work, the greater scope there was available for pursuing their own goals in interaction.

A further irony is suggested here: namely that, in conditions of task uncertainty as described above, the inability to fully define in advance the specification of the task and/or the responsibilities of the parties towards the management of the task, enhanced the likelihood of problems emerging in the relationship, and consequently of a more 'mechanistic' approach emerging in response. Because of the contractual vulnerability that this situation engendered, a premium was put upon a response that either lessened the parties' vulnerability in interaction, or enhanced their ability to take advantage of the others' vulnerability to pursue their own aims - assuming they had the motivation to do so. Paradoxically, a more 'flexible' contractual arrangement to deal with the uncertainties and interdependencies in the nature of the task - a perhaps appropriate combination - was more likely to lead to situations in which precisely the opposite tendencies emerged, given the motivation of at least one party to pursue their own goals in interaction, and the scope that was then afforded through the inherent ambiguities and omissions in the set of contractual terms and conditions employed.

The second main feature that was apparent was the extent to which an internal lack of cohesion jeopardised the position of the parties in external interaction. This was a particularly prominent feature in three of the design organisations (in the MTS, PDL and AFU cases) and in one of the main contracting organisations (in the RAW case), as noted towards the end of the last chapter. The general point to emerge here is that the more dispersed was the pattern of power within each subunit, and the

more that patterns of influence and control were ambiguous or shared, the more vulnerable was that party in their external dealings. Conversely, the more unitary, cohesive and clear was the internal situation, the less vulnerable was that party in external dealings. This appeared to be so across the cases in the sample. What was notable when contrasting conditions between the two more 'routine' projects and the three laboratory cases was that such factors, in the latter cases, belied the contrasting tendencies towards 'technical system' and 'business system' considerations noted above. On the one hand, the nature of the task tended to complement the more variegated pattern of power, influence and control. On the other hand, the fact that it occurred in the context of a contractual relationship between the parties prompted severe difficulties for the parties concerned in their handling of the project. In the previous chapter, the MTS case was singled out as giving a quite dramatic illustration of these contrary tendencies.

In summary, perhaps the main point to have emerged from this analysis is that the norm of a fully-fledged 'organic' system of management in a setting such as that described here may be to a large extent an aberration, given the salience of the inter-organisational, contractual dimension. As described above, this situation appears as if it may only be achieved in particular sets of circumstances, contingent upon characteristics of the inter-organisational relationship, and of the organisations involved in that relationship. If the situations and events on the cases are anything to go by, then it appears that the more necessary becomes a more 'flexible' approach to conducting the work (for

example, where design and construction processes extensively 'overlap' in a complex project setting), then the less likely this is in fact to occur. Given the scope that such a situation affords to the parties to pursue their own sets of goals in interaction with respect to the project, then for an appropriate, more flexible and 'organic' system of management to occur depends upon quite a unique patterning of circumstances that serve to reduce the motivation to exert influence, and to reduce the likelihood that such attempts will be successful.

The achievement of a sufficient level of 'integration' between the parties is similarly made more difficult as the salience of the contractual dimension increases. In an interorganisational setting such as that studied here, the heightened salience of organisational goals in interaction, coupled with disparities in the 'power' brought to the relationship by each of the parties concerned places a strain upon achieving a high level of collaboration and mutual accommodation. In most of the cases in this study, no explicit mechanism was formally employed to achieve integration between the parties. There was no effective recourse to a third party to settle disputes, conflicts and disagreements, and to supply a forum for resolving problems and reaching decisions in the more open and collaborative fashion emphasised by investigators of project management phenomena. Instead, the main linking mechanism was the contract itself, and the main forum was via direct lateral interaction between representatives between the main parties.

The problems tended to arise, on the one hand, due to ambiguities in the formal framework of interaction (in both its substantive details and procedural aspects), and its openness to competing and conflicting interpretation; on the other hand, due to the fact that the parties' stances in interaction were informed by separate and often conflicting interests, perspectives and assumptions, and their positions were bolstered or disadvantaged variously according to their organisation's power in interaction and its internal structural characteristics. In the case where an explicit integrative mechanism was employed (the managing contractor in the PDL case), these factors were by no means of any less importance to the processes of interaction with respect to the management of the project. The difference was rather simply that the outcomes were experienced differentially by different parties within the total project system; and that a tacit acknowledgment of the mutual dependence of the main parties upon each other emerged as the central dynamic that determined the course of events.

13.2 Discussion

The earlier discussion in Chapter 2 raised a number of questions concerning the applicability and feasibility of achieving preferred 'norms' of interaction in a situation essentially defined by organisational differentiation and associated divergencies in goals, orientations, attitudes and power. The discussion will now turn to addressing these questions again in the light of the findings described above. Attention was directed specifically towards the norms of an 'organic' system of management, and to

the use of structural mechanisms employed to achieve integration. These issues will be discussed in turn before discussing in more detail the implications of the findings for the norm of a 'culture' that is compatible with the requirements posed by the nature of the task in a project setting such as that described in this study.

13.2.1 The 'Organic' Task Team Group

What should have emerged from the foregoing analysis and discussion are the pragmatic difficulties that are encountered in developing and maintaining a 'team' approach to the management of project work in a multi-organisational setting. Clear tendencies were exhibited towards a more 'loosely-structured' approach to the management of the work across the cases. However, these coexisted with the (in cases) overpowering effects of the formal, contractual system that supplied the framework for interaction among the parties. Moreover, the existence of a perceived or actual external contractual 'threat' served (in cases) to put a premium upon a more, as opposed to less, structured approach towards the management of the work internally for the organisations concerned.

The discussion in Chapter 2 raised the prospect of these tendencies emerging: (a) within the single organisation, and contingent upon the direct impact of external dealings; and (b) within the multi-organisational setting, and contingent upon the salience of similar business system considerations. The results, while by no means conclusive, suggest the importance of the contractual dimension as an important moderating factor upon likely

internal and external forms and processes of interaction. With respect to the internal workings of a complex organisational system such as that found in construction, a clear tendency was found for situations of (perceived, expected or actual) external 'threat' to be responded to by recourse to more formal, structured mechanisms to co-ordinate and control activity. Conversely, the absence of more 'obtrusive' mechanisms of co-ordination and control served often simply to enhance the vulnerability of the one party in interaction.

From the findings, it is impossible to do other than speculate upon the longer-term implications for the character of internal structures and processes of management in these respects. However, the noted importance of starting assumptions and expectations (for instance, as it was reflected in the discretionary authority afforded to clerks of works) does suggest the possible appropriateness of a line of argument that predicts the association of a much more structured approach to the management of project work over time, with the salience of external dealings in the mainstream of organisational activity.

With respect to dealings within the project organisation as a whole, such starting assumptions and expectations were also found to be an important backdrop in defining the extent to which a more collaborative, flexible 'team' approach developed; or, conversely, the extent to which the parties acted more formally or 'contractually' with respect to one another. The situation that occurred and its development was found to be contingent upon the

range of contextual factors and their interrelationships in each case as described above. To the extent that these circumstances, and the reaction of the participants towards them, enhanced the salience of the contractual dimension, the more likely it was that the 'threshold' was bridged between the two approaches, and the more likely that 'rigidities' in interaction, as described by Sayles and Chandler (1971), emerged as a consequence. Perhaps the most important thing to bear in mind here is that it was somewhat more unusual in the cases described for this 'threshold' not to be met, than it was for interaction to arise and develop fully along more flexible 'team' lines from the outset and for it to maintain that course.

Several specific 'norms' of interaction were discussed in the earlier part of this thesis for which these findings have implications in the context of a multiorganisational project setting. Firstly, the norm of authority based upon individuals' (or groups') knowledge and expertise proves to be difficult to achieve where a business relationship and associated lack of mutual trust underpins the relationship. Where the level of trust in the relationship was comparatively low (due to initial expectations and/or reinforced by actual events), it meant that efforts to contribute knowledge and expertise to problem-solving and decisional processes were almost bound to be interpreted as attempts to obtain preferred outcomes (whether they actually were or not). The difficulty in such a setting becomes one of distinguishing between 'valid' interpretations based upon technical (design or construction) knowledge and expertise, and 'invalid'

interpretations that are perceived to be based upon preferred solutions to the issue at hand. Given the motivational backdrop supplied by the contractual relationship, the baseline assumption tends rather to be that differences in 'cause-effect beliefs' (Thompson 1967) in fact represent, and are symptomatic of, differences informed by divergent 'preferred outcomes' (ibid 1967). For instance, differences between the 'design point of view' and the 'building point of view' become difficult to distinguish from perceptions of 'the designer's interests' and 'the builder's interests' respectively. In such a situation it becomes more difficult to conceive of a pattern of interaction developing in which authority based upon knowledge and expertise is the norm, than it does a pattern of interaction in which one's position under the contract becomes the prevalent guiding influence.

Related difficulties emerge concerning the preference for a system of interaction in which decentralised decision-making authority and a spread of participatory influence in decisional processes constitute two related important features. Given the perceived importance of conflicting preferred outcomes in this situation, a premium is rather likely to be placed more upon making efforts to ensure that decisional processes fully reflect one's own organisation's interests in interaction, rather than those of one's contractual adversary. In other words the implicit tendency will be to control and influence the process of decision-making more directly, and to set limits to the extent to which the exercise by other participants of participatory influence in decision-making is countenanced. Rather than a conception of one's contribution

being related to the part played in the process, a focus on contractual rights and obligations prompts rather more a conception of contribution based upon one's role or position within the administrative network established under the contract.

Concerning the preference for a more 'loosely structured', informal and network system of interaction between the parties, a similar tendency for these norms to be contradicted is apparent in the emphasis that the contractual relationship puts upon: documenting decisions that have been reached; following procedural mechanisms to ensure that one's position is 'covered'; dealing more directly with single, rather than multiple, points of contact in other organisations to ensure that 'lines of communication are not crossed'; creating a datafile for use in the event of contractual difficulties and claims; making sure that definitive approval is given for decisions reached; and so on. The point here is that such tendencies may tend to emerge as almost necessary prerequisites, if the participants' vulnerability in contractually-based interaction is not to be enhanced.

The general point here is that such responses are essentially rational ones, from each organisation's point of view, given the nature of the underlying relationship between the organisations involved, and their potential vulnerability in direct dealings with external parties in a setting defined simultaneously by the uncertainty of the task, and the degree of surety embodied in one's contractual position with respect to the performance of that task. The literature on the functioning of complex project organisations

tends to regard such features as essentially aberrations to the norm of a more 'organic' climate of interaction amongst members of the task team group. The argument that has been pursued here is that, when one broadens the focus to the features of the setting within which the parties are expected to interact, and if one accounts for the fundamental difference in the motivational bases underlying interaction in an external setting, it becomes rather more the likely achievement of this set of interactive norms that emerges as the aberration. Further, if one takes the impact of external relationships upon the internal characteristics of the firm engaged in undertaking project work, it becomes possible to view the salience of the interorganisational dimension as a potential factor that may help to explain common aberrations to these norms observed and recorded by investigators in internal matrix and project management settings.

13.2.2 Integrative Mechanisms

With respect to structural mechanisms employed to achieve integration in the sense defined by Lawrence and Lorsch (1967), there are two major points here that pertain to conditions in an internal and external interactive setting respectively. The first, concerning internal systems of administration, is that the potential vulnerability of the organisation team in their external dealings puts a premium upon a more, rather than less, united and cohesive 'team' framework. Internal difficulties that compounded external problems were found to be associated with less direct patterns of control, greater ambiguity in patterns of

authority, and dual patterns of authority within the organisation. Conversely the more 'successful' parties in external dealings were able to present a more powerful and united 'front' and avoid attempts to exploit internal divisions.

This external dimension has a clear relevance for defining the level of influence of respective internal managers over subunit operations in a project setting, where the organisation is linked with external parties. It also suggests a major problem for the single organisation in adopting an internal framework that allows for a 'balance' in the objectives to be pursued. Specifically, in the absence of problematic external relations in the joint undertaking of project work, one would expect recommendations concerning the appropriate 'balance of influence' exercised by, say, project and functional managers within the organisation to hold. However, in the event of problematic external dealings, it becomes much more appropriate to 'tip' the balance of influence (cf Knight 1977) in the direction of project managers and the project objectives they represent. The organisation is faced with a quandary. On the one hand, if it maintains a framework in which the balance of objectives suggests the need for a comparative lack of formal influence of project managers over seconded functional staff involved in the team, it may be disadvantaged in external interaction. On the other hand, if it strengthens the position of the project management function to cope with external pressures, it does so at the possible expense of an 'imbalance' in the pursuit of organisational objectives with respect to the project.

The cases in this study have not been analysed such as to attempt to place a 'value judgement' concerning the appropriateness of respective levels of influence needed to achieve a 'balanced' approach towards the achievement of project objectives. Indeed, every effort has been made to explore comparative perceptions of 'appropriate' levels of influence attributed to the various parties and how these were regarded across the cases. However, it is difficult to come away from the findings without the impression that achieving such a degree of 'balance' internally for the organisations involved, or resolving the dilemma of autonomy or control, was of some significant importance. Further that configurations in the patterns of influence in this respect had an important bearing on their success in external interaction. Moreover, that the dilemma of achieving an appropriate balance between autonomy and control was a particularly problematic one on the three 'non-routine' cases in the sample where, in particular, the co-ordination of main structural and services work formed the focus for this dilemma.

The argument that is being pursued here is essentially that models of matrix management that seek to define the 'appropriateness' of a particular configuration of relationships that correspond to a specific balance between the objectives the firm is to pursue, essentially ignore the impact that external relationships in a project setting may have upon the efficacy of the model employed. If one looks solely at the nature of the task itself, and at the existing situation within the organisation, one may conclude, for instance, that a 'co-ordination' model (Knight 1977) forms the

appropriate mechanism. However, if one then takes into account the vulnerability this may lead to for the organisational team in external dealings - through, for instance, the limited direct influence and control exerted by the project manager - then one may conclude that a 'secondment' model of interaction may be more appropriate. More generally, the organisational design issue may become one of striking a balance between the set of comparative levels of authority and influence within the organisation, and the set of requirements as they are affected by likely patterns of external dealings within the multiorganisational project system.

The second major point concerns patterns of integration between parties within this wider system. The point has already been touched upon in discussing the divergent orientations associated with the 'design viewpoint' and the 'construction viewpoint'. Moreover, as noted above, the salience of the contractual dimension heightens (actual, expected or perceived) goal divergencies in interaction, such that the degree of 'collaboration' one might expect to occur is heavily constrained by 'business system' factors. This is not entirely the case, of course. Indeed, some of the evidence pointed to what amounted to highly convergent orientations across organisational boundaries (cf the M & E services on the MTS and PDL cases); moreover, the evidence suggested important points of convergence in relation to the goals being pursued when a more complex (eg triadic) system of relationships was looked at (cf the main contractor - PQS collusion on the PDL case).

Nevertheless, the particular difficulty in this type of setting clearly stems from the heightened salience of divergent economic interests in interaction. In models of matrix management that are applied in an interorganisational setting, the tendency is not fully to account for the essential difference in the premises adopted in interaction that this factor engenders. Moreover, the important focus upon power differentials in interaction in relating these to the technical characteristics of the task, underplays this important underlying dimension. When one takes this into account, sets of quite different interpretations and recommendations potentially follow. What was a particularly prominent characteristic of most of the cases investigated in this study (with the exception of the AFU case), was that the particular configurations of established project objectives (time, cost and quality) were such that they could only really be effectively and fully achieved if at least one party (or group) was disadvantaged to some extent and in some way with respect to achieving their own aims on the project. In some cases the 'balance of objectives' achieved was predicated upon extra financial cost or loss to the parties; in other cases it was predicated upon the relaxation of the standards of the specification and the quality objectives achieved. A useful analogy might be to describe the situations as those in which 'pressure in the system' due to incompatible and contradictory objectives was built up. This 'pressure' had to be released somewhere: the factors that influenced the respective vulnerability of the parties and their patterns of mutual dependency were those that combined to suggest where this 'pressure' might be released.

In this type of situation it is difficult to see again how parties' perceived contributions may be effectively de-coupled from their perceived interests. Further, how a system for achieving integration that is appropriate to circumstances in a more normatively-consistent internal setting may be equally appropriate to circumstances in which highly divergent goal orientations are the norm. The position and influence exerted by the integrator in an internal matrix setting has received considerable attention in the literature. In most of the cases studied here, no formal system for achieving integration was observed (the constraints and limits upon the clerk of works as the individual most close to occupying this position in practice, have suggested that their position tended to prompt the exercise of more direct, centralised control, rather than allowing them the autonomy and independence to perform this role). In the case in which a formal mechanism existed (the PDL case), the inferences to be drawn are that:

(a) their ability to rely upon more informal bases of influence other than positional power within the 'management team' was constrained by divergent assumptions and expectations concerning where their 'interests' in fact lay; and (b) that the tendency was for their expressed 'neutrality' to be somewhat compromised by the close association of their own, and the client's, interests. Despite, in this case, an explicit mechanism employed to promote collaborative working relationships, the salience of divergent interests meant that this aim was never really achieved on the project (although it was largely successful with respect to achieving time, cost and quality objectives).

In summary, if one is to look at the phenomenon of the performance of an 'integrator role' in a multiorganisational setting, one has to account for the impact of the highly divergent goal orientations in the performance of this role. In a situation where perceptions are guided by concern as to the actual 'neutrality' of the integrator, the baseline of trust and willingness to accept that integrator's influence (and, conversely, to accept the limits to the direct control exerted over the incumbent), make the effective performance of the role as defined in the matrix management literature, a highly problematic one. While the role in an internal setting may be a highly difficult and challenging one, it is argued here that, in an external setting, it may be virtually impossible. That is, assuming one judges the effectiveness of the role according to the types of criteria specified by matrix management theorists.

For the incumbent of the role, the situation is fraught with problems of role ambiguity and conflict. Although this study has not directly investigated the impact of these phenomena, it is clear from much of the earlier discussion how those in a position of 'straddling' the divide between the organisations involved respectively in 'design' and 'construction' activities were at the centre of milieux of conflicting expectations and assumptions concerning the interests that informed their approach towards the management of the work. Further, those incumbents (including those involved in the PDL case) were imbued with comparatively little in the way of formal influence to 'manage' the relationship between the parties. In an internal setting, the exercise of

influence based upon 'sapiental' authority (Patterson 1966) is expected to make up the shortfall. In an external setting, where the conditions do not necessarily exist for the acceptance of the validity of influence exerted upon this basis (see above), an exercise in 'political' manoeuvring, tact and diplomacy may be the more essential weapon in the integrator's armoury. Such a differing emphasis clearly has the potential for prompting the efficacy of a somewhat different 'style' of interaction of the integrator as leader in a multiorganisational project setting, where situational conditions are comparatively much less 'favourable'. A recent article by Halsey and Margerison (1978) - a discussion of the situation on very large contracts - serves as an interesting and relevant aside to this series of points concerning the position and influence of the managing contractor as 'integrator' on construction projects. The discussion there points to the efficacy of a much more directive approach adopted by the integrator in interaction, based upon a recourse to, and emphasis upon, the sets of formal terms and conditions of contract that bind the parties whose activities they are attempting to co-ordinate. In the cases explored in this study this more directive or 'authoritarian' stance was much less possible given the comparatively weak formal positions of those performing the role, and their dependence upon the parties for whom they were working. However, the distinction does suggest the importance of variability in the position and role of the integrator for determining the possibilities available. More importantly perhaps it illustrates that the appropriate dimension along which the integrator's influence varies consists rather more of the level of formal control that they can exercise - rather than their

exercise of 'sapiental authority' (Patterson 1966) as in an internal matrix setting. The general point to be made here is that the salience of a contractual dimension, and the pressure upon those performing integrator roles to follow one set of interests or another may combine to limit the extent to which patterns of influence based upon bases other than that of formal positional power (ie knowledge, expertise), are likely to be effective in 'bringing the parties together' in an external setting.

13.2.3 'Cultural' Compatibility

The general question was earlier addressed concerning the 'cultural' compatibility of the antecedent organisation with that required in the new forms of organisation described in Chapter 1. What was clearly in evidence in the cases studied here was a 'cultural' set of norms part of which was the inherently adversarial nature of the relationship between the parties to the contract. This did not necessarily manifest itself in any direct conflict between the parties - take, for instance, the AFU case. However, even here, a notably guarded and cautious approach was engendered. Moreover, possibilities of obtaining advantages stemming from internal divisions were recognised, if not actually pursued. This essentially competitive and adversarial nature of the relationship has been firmly associated by construction management researchers with the type of setting in a more 'traditional' form of administrative arrangement. However, what was particularly interesting about the PDL case, was the extent to which these norms were carried over into a situation which was ostensibly

free of that type of antagonism between the main parties. The 'management team concept' may have been the articulated norm; however, it was a norm that proved difficult to achieve, given the strength of expectations and assumptions informed by previous experience of working in more 'traditional' settings.

For those interested in the development and maintenance of more complex organisational forms, these findings present something of a quandary. In a multi-organisational project setting, and where relationships are notable for their transience, there appears to be neither the opportunity nor the incentive for the parties to develop a (project) organisational 'culture' which is consistent with the types of requirements posed by the nature of the task. On the contrary, the incentive is perhaps rather more for a cautious or competitive, adversarial approach to be adopted that lessens the likelihood that such a transformation will be achieved. Moreover, to the extent that novelty in the relationship is the starting position, and brevity in the relationship is an important factor, it appears further unlikely that initial preconceptions and assumptions are likely to give way to a greater mutual understanding and degree of accommodation between the parties. Even in the absence of residual direct conflict between the parties, it appears still likely that a learning process might be involved that militates against full and open collaboration from the start.

More broadly, the problem in an interorganisational setting is of pursuing the equivalent of an organisational development or

management development programme to achieve a 'cultural' transformation that corresponds to what is required by the nature of the task being performed. Put simply, the ability to achieve an appropriate (project) organisational 'culture' is prejudiced against by the fact that the setting is a multi-organisational one (with the interesting exception in this respect of the design and construct situation). As described in Chapter 3 earlier, the possibilities for better communication and co-ordination are felt to be militated against by the highly developed 'role culture' within the industry. The problem becomes one of generating some form of consensual view of the appropriateness of certain forms and types of interaction in a setting essentially defined by dissensus (in values, norms, goals and objectives).

Alternative forms of delivery system (eg management contracting, design and construct) may suggest an alternative strategy - of changing the structure of relationships between the parties, rather than attempting some form of cultural transformation within the existing 'traditional' system of working. What the findings from the PDL case suggest, however, is the necessity for such structural changes to be accompanied by a change in perspectives concerning the nature of the roles performed by those involved. Given the nature of the industry, however, it seems unlikely that such changes may fully occur: particularly to the extent that such alternative methods are advocated by one group (ie builders). To be successfully implemented they may require fuller acceptance on the part of other groups (ie clients, designers) of either their unambiguous benefits or the unambiguous costs of continuing to

employ a more 'traditional' set of arrangements. The question that is then suggested is: what benefits and costs are entailed for the parties in a move towards an alternative type of arrangement than that 'traditionally' employed; and can one expect that attempts to employ such a framework that has 'costs' for one or other of the parties will necessarily be accepted willingly and without resistance.

The problems that occur in their implementation (cf the PDL case) may arise largely due to the fact that the premises that underly the different forms of arrangement simply contradict those that underpin 'traditional' (and more extensively occurring) forms of arrangement in which the main parties are, to all intents and purposes, contractual adversaries. For those participants involved, such a change to an alternative system heralds a move towards a differential pattern of control and influence over the total design and construction process. While it is clearly too much to generalise findings from the one case study to circumstances within the industry as a whole, the types of issues that were raised on the PDL case suggest a line of enquiry worthy of future investigation. Specifically, given attempts by organisations to control sources of uncertainty in their environment (Thompson 1967), and given the traditional organisational split within the industry between design and construction processes and the relative locations of professional and other groupings in the organisational 'cluster' that manages project activity (Higgin and Jessop 1965), it may be worthwhile to pursue the issue of organisational control of the total project processes at a more aggregated, institutional level within the industry. In other words, irrespective of the 'technical' merits of different forms of project delivery system, they have

implications for conditions of 'domain' dependence at an organisational level, and of the same for professional and other groupings at an institutional level. What is being suggested here is the potential importance of an historical analysis of the industry that employs as its framework the notions of organisational domain and efforts to control contingencies. This may help explain past developments and current dynamics in the relationships between the organisations involved at a broader, industry-wide level.

For those interested in the 'cultural norms' of matrix and project management systems, the findings and the interpretations placed upon them suggest the importance of time and longevity as a means of approximating moves towards a consistent 'culture' of interaction, and avoiding the impact of cultural 'clashes'. This has two components: firstly, the extent to which relationships amongst organisations in a project setting (and their group or individual representatives) are recurrent; secondly, the actual length of duration of the relationship. In the first case, mention has already been made (in Chapter 4) of the impact of continuing interorganisational linkages as a control mechanism for managing dependent organisations (Sayles and Chandler 1971). Such an interpretation is lent some strength by the findings reported here. However, perhaps just as significantly, a longer-standing relationship may promote conditions in which achieving some degree of cultural consistency is possible. In effect, recurrent experience in the same relationship may foster a much closer orientation towards managing the project (although the NSS case shows how these conditions may 'break down' in certain circumstances: the consistency

is at best a tenuous one). At least prior knowledge and experience of working together may reduce the 'learning curve' associated with reaching a position of mutual understanding of others' positions.

With respect to the longevity and duration of interorganisational linkages in any particular project setting, one would expect that, assuming the absence of problems in the relationship, a longer relationship would at least contribute towards a better understanding over time of each party's position and orientations. The findings reported here give no direct indication that this may be the case. However, the importance of continuity and longevity has become increasingly recognised as a factor influencing the development of relationships within the construction project setting (eg Bryman et al 1986) and deserves fuller and further attention. This is particularly so in studies of matrix and project management, where a situation that is essentially defined by the 'cyclical' nature of project activity, tends to generate little direct interest in the potential importance of variation in the phenomenon of transience. As suggested above, it may be of particular interest in investigating the extent to which 'appropriate' cultural norms have an opportunity to develop.

13.2.4 'Leadership' in Project Systems

A good deal of attention was directed, in the early part of this thesis, towards the issue of leadership processes and 'styles' of interaction in the type of setting studied here. The

particular methodology that was employed in this study did not allow for either a full assessment of the processes involved, or the ability to make full and direct comparisons with findings obtained in other types of setting (due to a departure from the more usual standardised and structured techniques extensively employed in leadership research). However, in the description, analysis and discussion of the findings, certain tendencies were noted to have emerged with potentially important implications for studying the processes involved in such complex settings. Such tendencies further suggest that this topic may provide a potentially fruitful area for further research.

Firstly, the noted tendencies towards 'rigidities' in patterns of external interaction, were complemented in many cases by commentaries which suggested the tendency towards the adoption of more directive or 'autocratic' approaches (Vroom and Yetton 1973) to the management of the work on site. Several comments were made which suggested that the tendency towards decision centralisation within the wider project organisation was due in the main to manifestations of a 'stylistic' interpretation by senior managers of how to approach the project in order to exercise their influence and control over the processes of decision-making. These tendencies were somewhat common to both internal relationships within organisational teams, and externally in dealings with other parties. In the latter instance, the experienced 'dissatisfaction' of those at the 'receiving end' was implicit in much of their discussion of what they felt had been the consequences. However, any direct impact, one way or the other, upon the actual levels

of performance realised cannot be inferred from the findings. Furthermore, establishing the effects of such approaches contingent upon situational conditions (task complexity and so on) proves a difficult exercise given the nature of the data presented.

The more significant and interesting point emerges here, however, if one takes into account the impact of situational factors as conditioning influences upon the types of approach adopted. Specifically, the fact that the setting was an inter-organisational one appeared to suggest that a premium was put upon the adoption of a more directive, instrumental and 'authoritarian' stance in joint interaction. This tendency becomes apparent if, for instance, one compares the comments made concerning the (perceived) too directive 'styles' of the Project Managers in the NSS, AFU and PDL cases, with the (perceived) lack of direction given to the design team in the MTS case, and the (perceived) effects of the somewhat laissez faire approach of the Site Agent in later stages of the RAW project. In the last two situations, moreover, these approaches were contrasted with the (implicitly) more directive approaches adopted by their counterparts in the other main participating organisations.

The point that emerges here is that it was the salience of the contractual dimension that promoted the perceived efficacy of a 'style' of interaction that was geared towards maintaining more direct, personal control over events on the project. Given the earlier comments made concerning the limits to the exercise of participatory influence in a multi-organisational setting, this

also tended to be expressed in the conduct of relationships in a somewhat more 'autocratic' manner. Those in de jure leadership positions had effective recourse to their power under the contract to secure compliance, as opposed to pursuing a more participatory line to create conditions for 'acceptance'. The approach was conditioned or engendered more directly by a reliance upon one's formal position power afforded under the contract, combined with expectations that otherwise the 'adversary' would be enabled to pursue their own interests in interaction. In an internal setting, the inference that can be drawn was that tendencies to exert more direct control in this way were consistent with the need to ensure that the goals that those participants represented were fully achieved and, in the context of problematic external relations, to ensure that any attempts made by their contractual 'adversary' to take advantage of potential or actual internal divisions within the team were countered by more direct, centralised influence and control.

Assuming it is possible to draw such inferences from the data obtained, then a further difficulty is encountered in translating the norms of a 'style' of leadership that generates, fosters and facilitates participative interaction from an internal to an external setting. Furthermore, to the extent that such external dealings affect perceptions of the need to exert more direct and centralised control, the tendency may be contrary to what is perhaps needed internally, given the nature of the task being undertaken. Concerning the nature of the task and what may be an 'appropriate' response, given the complexity of work and so on, these inferences

suggest a further quandary. Namely, that more complex and uncertain conditions may create exactly the types of circumstances in which a more, rather than less, directive approach is actually pursued. This to the extent that uncertainties heighten the organisation's vulnerability in interaction, such that it is perceived that the achievement of organisational objectives is potentially threatened.

Clearly this area needs further and fuller investigation, if one is to draw any firmer conclusions. However, two tentative suggestions may be made as possible propositions worthy of specific study: firstly, that in an interorganisational project setting, and to the extent that relationships with external parties are (actually or expected to be) problematic, then one's formal authority under the contract acts, in effect, as a 'substitute for leadership'. Secondly, that in the presence of problematic external dealings, the response internally is likely to be a more directive or 'initiating structure' style of leadership.

A second issue that bears brief mention with respect to leadership processes and 'styles' of interaction generally in a multiorganisational project setting, links back with the earlier points raised concerning the fact of (project) organisational transience, and variation between projects in this respect. Across the cases an important emphasis was placed by many of those involved upon the 'cohesiveness' of the team, and the importance of interpersonal relationships within the group at the outset and throughout the project's development. Sufficient references were made to comments such as "it all depends on relationships' and

"personalities are very important" to suggest that the manner in which the 'team' developed depended importantly upon individuals' stances in interaction and their responses to circumstances and events. The comments made on the PDL case concerning the difficulties experienced in getting the team to "gel" serve here perhaps as an illustration. Such a phenomenon is by no means surprising. Indeed, the importance of interpersonal relationships and orientations and generating a 'team' approach are important underlying features in all prescriptions for the extension of 'lateral relations' (Galbraith op cit) within complex organisational settings. This discussion has focused considerably upon the contextual factors that define the conditions under which individuals and groups conduct lateral interaction. An important final two points, with implications for possible future avenues of research concern the impact of time as a parameter for processes of joint interaction.

Firstly, such project settings are essentially characterised by the fact that members of the 'team' (unlike perhaps in internal settings) are likely to have little prior knowledge of one another and little direct experience of working together. The relationship is a project specific one and the 'team' is unlikely to be reconstituted fully in subsequent interorganisational dealings. Such a factor clearly helps to explain the 'learning process' involved in the initial stages of interaction, where preconceptions may form the guiding influence. What they may further help to explain are the interpretations noted above of tendencies towards a more directive 'autocratic' style. The criticality of the

business relationship, expectations concerning others' likely responses, and a desire not to take risks in this type of situation - which is only a temporary, transactional relationship anyway - may engender a much more cautious and instrumental approach in exercising leadership. Of course, continuity in the relationships at an interpersonal, as well as group or organisational, level may well be variable (cf the situations on the RAW and AFU cases). Moreover, the longevity of the particular relationship with respect to one project may vary. What this implies though, for those interested in investigating such phenomena in complex and temporary project organisational systems is the need to more fully take into account variation in the time scale of interaction as a potential important conditioning influence upon the development of 'team' relationships (eg Bryman et al 1986). Further, what this means in contrasting internal and external matrix management settings, is the potential importance of the comparative timescale of interaction as a differentiating experiential factor.

The second point to be raised is that it becomes more important, in a transient project-based setting to explore various paths that the development of 'team' relationships can take, set in this context of initial (. varying) lack of experience of working together at an interpersonal, as well as group or organisational, level. The above inferences concerning leader orientations and 'styles' have been made largely with respect to the position of de jure 'leaders' (both internally and within the wider project organisation), and have presented an essentially static overall view of circumstances across the cases in this respect.

Indeed the data obtained do not allow fully for an exploration of the dynamics involved with respect specifically to leadership processes within the group at an interpersonal level. However, given the above, it becomes potentially of greater significance to explore more fully developmental aspects of the group's functioning: most notably patterns of interaction at an interpersonal level within the team that may suggest informal and emergent patterns and processes of leadership in a project setting. It is suggested generally here that a greater awareness must needs be taken of developmental aspects of the group's functioning - including the exercise of 'leadership' - in a situation defined by its novelty and transience, and where the parties are essentially unfamiliar with one another, to varying degrees, to begin with. A number of leads have been suggested by this study: including the importance of divergent starting assumptions and expectations. There is a need for more research in this area if one is to fully understand the functioning of complex organisational systems.

13.3 Areas for Future Research

A final series of points need to be made in this chapter, before drawing to a close, concerning a potential area of future research that has not already been mentioned in the previous section. This concerns the impact of group and organisational size upon extant forms and processes of interaction and relates back to the earlier discussion in Chapter 2. While attempts were made to account for the direct influence of size variables in this study, a discussion of the effects of size has not been

attempted until now due to the difficulty in assessing the impact of size per se in the analysis of the data. This was due to two factors which confounded a direct analysis of the effects of size, given the small number of cases investigated. Firstly, problems of drawing comparisons and contrasts between the cases with respect to the effects of size when differences in the complexity or 'non-routineness' of the work involved also varied. Here, for example, comparing the RAW/AFU and MTS/NSS cases was made impossible due to major differences also in the nature of the work being undertaken. Secondly, similar problems of comparison when characteristics of the business relationship involved were profound. Here, exploring similarities and differences between the PDL and MTS/NSS cases was confounded by the very different type of contractual system employed, and also possibly by the fact that the latter cases were particularly noted for the problems that occurred in contractual dealings between the main parties. It is possible only really to speculate that size may have had an impact as a co-variable or moderating factor. However, the results do not allow for any firm inferences or conclusions to be drawn with respect to the effect of size per se.

Nevertheless, it is argued here that regard to the potential impact of size variables is important, for the reasons described in Chapter 2, in conducting future studies of the forms and processes of interaction in complex organisational settings. What characterises the research base into the workings of complex organisational forms (and of project organisations in construction) is the heavy emphasis placed upon investigating these phenomena

in large, and thereby high complex, settings (eg Sayles and Chandler 1971, Halsey and Margerison 1979, NEDO 1970). It is tempting to suggest that the scale of operations, and the resulting complexity in systems of management and administration make a focus upon such situations the preferred approach since those situations become those in which the operation of such complex organisational forms becomes more problematic. However, this should not detract from equally problematic tendencies that are apparent in the much smaller scale of operations typified by the types of project investigated in this study. More importantly, however, there is a need to more systematically investigate similarities and differences between different size ranges of operation, in order to allow a clearer understanding of the comparative impact of task characteristics and the scale of the task, and the potential inter-relationships between those two sets of factors. Some tentative leads may be suggested by particular findings from the research: notably perhaps the differential patterning of main contractors' site-head office involvement between the two smaller and three larger cases, and the extent to which this was associated with differences in the locus of discretionary authority available to members of the site team (although, as noted above, this was perhaps rather more as a response to the problems faced in external dealings). The main general point to make here, however, is rather that the findings do not invalidate the earlier call for taking into account the potential impact of (project) organisational size.

Before concluding, it is worthwhile to briefly summarise the main line of discussion pursued in this chapter, following from the analysis of the data and the presentation of the findings of this study. It is essentially that the norms of interaction deemed appropriate to the development of an integrated, interorganisational relationship in a setting such as that studied here, are in fact the more difficult to achieve and maintain, the more that task circumstances heighten their importance. The problems of 'rigidities' in interaction that may emerge are essentially rational organisational responses to a problematic interorganisational setting. The problem is that, as the task undertaken becomes more complex, uncertain, fragmented and so on, these very sets of conditions are precisely those that may engender a response that serves to reinforce these tendencies. The discussion has then suggested two major implications. Firstly, that studies of complex organisations operating in a project environment need more fully to allow for the impact that such external conditions may have upon the internal functioning of the organisation. Secondly, that such studies need more clearly and systematically to address differences between situations in which external contractual, rather than internal organisational, relationships occur, since they imply a qualitative difference in the basis of the relationship underpinning lateral interaction.

CHAPTER FOURTEEN

CONCLUSION

This study has focused upon the forms and processes of interaction that occur in the organisation and management of projects, taking as its focus of interest the case of the construction project and, as its database, five illustrative case studies of projects undertaken in the UK construction industry. The background to the research has been the widespread interest that has developed, in recent years, in studying forms of organisation and processes of management in complex project settings. The rationale for the particular line of enquiry pursued here has been the comparative absence of investigations of construction project activity, management and organisation in research undertaken into the operation of complex project organisational forms; and a belief that focusing upon the case of construction allows for an important contribution to this growing body of knowledge. The rationale underpinning the research strategy pursued has been the exploratory nature of the research; and also a concern with examining in detail patterns and processes of interaction in a project management setting as they relate to the complexity of the situation characteristic of this type of setting, and the dynamic of change in these circumstances over time.

In the early chapters one to four, the theory and research base into organisational patterns and managerial processes in complex project organisational settings was discussed and reviewed, and related to the types of situation found in the case of

construction. In the first half of Chapter 5, this discussion was gathered into a model of expected patterns and processes of managerial interaction, from which a series of propositions for empirical investigation were derived.

The main thrust of the argument presented in this earlier part of the thesis, was that contradictory tendencies emerge in the organisation and management of project work if one takes fully into account the potential or actual salience of inter-organisational relationships in the joint management of project task work. On the one hand, the nature of the task may make appropriate a more 'flexible' responsive and adaptive approach to managing complex and uncertain project taskwork. On the other hand, the importance of the contractual basis of interorganisational relationships may engender a more 'rigid', cautious and possibly inappropriate response to the situation encountered. This argument was related to the earlier-discussed models of complex organisation by addressing two sets of implications. Firstly, that for the single organisation operating in a complex project organisational 'system', the salience of inter-organisational contractual relationships may make for an internal 'climate' of interaction that in fact violates many of the principles and norms set out by those attempting to address the most appropriate means of organising and conducting activity in complex and uncertain task environments. Secondly, that the differential basis of motivation that is associated with transactional, rather than organisational, relationships between participants in a complex project setting, must needs define a point of departure in the investigation of project organisational phenomena (eg matrix management) as between intraorganisational and interorganisational

project settings. The tendency for those interested in the operation of complex project organisational forms not to give much systematic attention towards the potential impact of external relationships (and variation in this dimension), nor fully and systematically to differentiate between internal and external relationships in interaction, formed the backdrop to this discussion.

In the second half of Chapter 5, details were given of the research strategy adopted and the methodology employed in this study. Particular attention was addressed towards the exploratory nature of the research, and its manifestation in a longitudinal, case study approach to the investigation of the phenomena of interest; involving an extensive reliance upon the use of qualitative techniques for the collection, presentation and analysis of the data. Chapters 6 to 10 described each of the case studies in turn in some detail. Following this, in Chapter 11, comparisons and contrasts were drawn with respect to the circumstances observed across the five case studies. In Chapter 12, a more detailed inter-case analysis was undertaken, and a 'diagnostic' interpretation of events on each case was undertaken in the context of the circumstances described and discussed in Chapter 11. This broadened out, in Chapter 13, to a discussion of the main findings; their implications in the light of the discussion in the earlier part of the thesis; and areas of potential future research interest.

The main findings of this study concern the paradox that emerges when one considers the contradiction between: the forms and practices of organisation and management that are deemed

appropriate to the performance of a complex and uncertain task; and the likelihood of them actually being achieved and maintained, given the salience of the contractual dimension in the relationships between those participants involved. The interpretation that has been drawn is that such complex and dynamic conditions in fact engender a greater likelihood that practices that are deemed appropriate will not occur. Several important features concerning the organisational participants and their relationships - notably patterns of goal convergence and divergence; internal patterns of authority, influence and control; and wider patterns of power-dependency - were identified as important moderating factors in defining the extent to which this was the case. Further, attention was addressed to the internal implications for the individual organisation engaged in joint interaction in the management of construction project work.

The research has been exploratory in nature, and a good deal more attention needs to be directed towards the factors explored in this study and their interrelationships in a project setting before firm conclusions can be drawn. However, the findings do suggest a number of implications for the body of theory and research discussed in this thesis, and a number of lines of enquiry that might prove fruitful avenues for further research.

The general implications for those interested in studying matrix and project 'systems' of management, is the need to take account of interorganisational relationships in the investigation of project organisational phenomena. As noted earlier in Chapter 2, much of the research undertaken in this area seeks to analyse a

situation which is essentially defined by the articulation of operational constraints and contingencies by bodies (and their agents) external to the focal organisation. The construction setting may be essentially characterised by the greater importance of interorganisational relationships in the management of project work than in other types of project setting. However, even given this quantitative difference, the qualitative similarity associated with the multi-organisational performance of project work in various types of project environment needs to be taken into account, and the (potential) impact of external working relations at least accounted for.

Related to this, external relationships between 'functional' groupings in wider project organisational 'systems' need to be fully differentiated from relationships in internal situations due to the (potential) impact of the qualitatively distinct motivational basis that underlies interaction in the two cases. This research has lent some strength to models of project organisation and management that focus upon goal and power differentials and disparities in interaction as fundamental underlying dynamics that may characterise interrelationships among organisational subgroupings. However, in linking these disparities to organisational differentiation within the project organisation as a whole, the clear importance of contractual relationships in defining patterns and processes of interaction within a total project organisational 'system' has emerged as implying a qualitatively distinct and important factor.

A further general implication, is in the applicability of constructs and models derived from the investigation of complex project 'systems' to a situation such as construction project management. As noted in Chapter 2 earlier, the focus of research attention has often been upon idiosyncratic types of setting and, in particular, high technology, large scale undertakings. The findings in this study suggest that the small scale, lower technology setting of a construction project may provide suitable opportunities for the fuller exploration of project management phenomena. The foregoing discussion of the (potential) impact of external relations illustrates how findings from the study of such situations may provide useful insights into the phenomena of matrix and project management in general.

For those concerned specifically with investigating construction project organisation and management, the findings suggest the importance of taking a broad view of the situation involved when studying the patterns and practices of management observed on particular sites. The problems associated with integrating design and construction processes, and the difficulties of overcoming the organisational/contractual divide have, of course, long been recognised (eg Higgin and Jessop 1965, Crichton 1966, Morris 1973). However, the moderating effects of goal dependencies and power relationships between participant groups, and their variation from case to case need also to be taken more fully into account. Rather than focusing solely upon perceived highly problematic situations (and also upon complex situations made so partly by the fact that the scale of operations is large to very large), a greater awareness of variation between cases contingent upon a variety of

sets of circumstances needs to be developed.

Broader issues concern the investigation of relationships between professional and other groupings at the level of the industry as a whole - focusing upon historical developments in their positions within the overall 'technological matrix' (Selznick 1949) that defines the total design and construction process. Further attention might appropriately be directed towards the implication of sub-contracting - a phenomenon that has tended to increase significantly in recent years (Bresnen et al 1985) - and implications for the complexity of patterns of authority, influence and control in the management of construction project work.

Two final sets of implications need briefly to be addressed. Firstly, the research has illustrated the usefulness of adopting, in part, an interorganisational perspective in investigating the phenomenon of project management in a setting such as construction. It is hoped that this, and similar types of setting may prove useful avenues for the examination of interorganisational relations between business organisations, to add to and complement the growing body of theory and research in this area (eg Negandhi 1980).

Secondly, the case of construction needs to be brought more fully into the mainstream of organisational theory and research. This study has focused upon a situation in which the single organisation (eg designer, contractor, subcontractor) acts more closely in concert with other organisations involved in the performance of a common task. The planning and ordering of work and its meaning

to those involved - which are the essence of the strategic choice decisions made by the organisation (Child 1972) - are closely constrained and influenced in this case by the strategic choices exercised by external parties. These include decisions made with respect to the nature of the task being performed and the system of administration and management established for its performance. The difference this implies when compared with the relative autonomy of firms acting in other types of setting (eg manufacturing) can only lend weight to calls for the fuller inclusion of 'special cases' such as construction into mainstream organisational theory and research. This would allow for fruitful comparisons and contrasts to be drawn when addressing the nature and organisation of work activity in industrial society in general. Whether the case of construction is an 'exception to the rules', or whether it contributes towards a fuller understanding of the rules, remains to be seen.

APPENDIX A

QUESTIONNAIRE

(Note: These questions were used as a checklist to obtain information about the project, its organisation and management, and were left open-ended. Field notes were taken in interviews, from documentation, and in direct observation, and the information obtained related back to the questions. The format here reflects the fact that the questionnaire was therefore not 'filled in' by respondents as such.)

The Project

1. Describe the project being undertaken and the types of work it involves.
2. Is the project a 'one-off' undertaking, or part of a wider development?
 - (a) If 'one-off': describe the particular client requirements.
 - (b) If part of a development: describe the nature of the development, and the part in it played by the project.
3. Where is the site for the works?
 - (a) Describe any main features of the locality that have a bearing on project design/construction.
 - (b) Describe any main features of the site ground conditions that have a bearing upon project design/construction.

4. (a) How long is the planned duration of the project?
(b) Describe the planned programme of operations during construction.
5. What is the estimated total cost of the works?
6. (a) What types of production techniques are involved in its construction?
(b) Are all the works to be built in situ, or are some elements built off-site? Describe these elements.
7. What types of plant and materials are used in its construction?

The Participants

1. Which organisation is the client for the project?
 - (a) Who are the users of the facility?
 - (b) From what source is the project funded?
2. Which groups are involved in the design and planning of the project?
 - (a) Are these groups in house or contracted agencies?
 - (b) If contracted, under what terms and conditions; and how were they selected/appointed?
3. Which company is the main contractor?
 - (a) Under what conditions of contract are they employed by the client?
 - (b) How was this company selected/appointed?

4. Are subcontractors contracted to undertake any of the work? YES/NO
- If YES: (a) Which sections of the work?
- (b) Are they 'nominated' or 'domestic' subcontractors?
- (c) Under what conditions of contract are they employed?
5. Are any other organisations (eg suppliers) involved directly in the project? YES/NO
- If YES: (a) Which organisations and what part do they play?
- (b) By whom are they employed, and under what conditions?
6. For each of the main organisations involved:
- (a) What is their nature of business?
- What types and sizes of work do they commonly undertake?
- (b) What is the size of the organisation (in output/employment/assets)?
- What is the divisional/branch structure of the organisation (if appropriate)?
- (c) Describe any prior experience of working with other main parties involved on this project.
- (d) How significant is this project (in relation to turnover)?
- Does it have a significant impact upon organisational features?
- (e) What are the objectives of the firm on this project?
- What have been the considerations that have influenced the decision to take on the project?
- Are there any likely 'spin-offs' to successfully undertaking the work?

- (f) What other types of concurrent work is the organisation performing?
Is any of it with the same main parties?
- (g) How 'typical' is the type and scale of work undertaken by the organisation on this project?
Does it involve the use of any 'new' techniques or processes? If so, describe them.
- (h) What are the organisation's role and responsibilities on the project during design/construction?

Design Activities

1. How long was the duration of the design stage?
2. Describe the activities that were involved in establishing a design for the project, and the stages at which they occurred.
3. Were these activities 'routine' or specific to this project?
 - (a) If routine: describe the reasons for any divergence from 'normal practice'.
 - (b) If specific: describe 'normal practice' and the reasons for the divergence from it in this case.
4. What were the major considerations taken into account in establishing the design?
5. Were major design alternatives proposed at any stage?

YES/NO

If YES: what choices were made, and why?

Design Organisation

1. Who determined the design team structure, the selection of personnel, and the assignment of tasks to participants?

2. Was one individual put in charge of the total design effort? YES/NO
 - (a) If YES: who was this individual (eg PM) and to whom did they report?
 - (b) If NO: how was the design team constituted, and to whom did the team report?

3. Where was the organisational and physical location of the project office and groups/organisations providing administrative support during design? (Enclose organisation chart if available).

4. Which personnel were appointed for, and involved in, establishing a design plan for the project?
 - (a) From which departments did these personnel originate?
 - (b) Were they seconded to the project team full-time?
 - (c) Upon what basis were personnel selected and appointed?
 - (d) What part did they play in the design process?
 - (e) To whom did they report and in what ways during design?
 - (f) Did their involvement continue beyond the design stages? If so, what was their role?

5. For each individual/group involved in design, did their respective functional manager(s) play any direct part in supervising their work on the project? YES/NO

- (a) If YES: describe their involvement.
- (b) If NO: describe any part they played in providing ongoing support services, training, etc for staff members involved in the project team.
6. Describe the patterns of communications and coordination between team members during design.
7. What formal procedures, if any, were established for liaison between project team members during the design stage (eg briefings, meetings, etc)?
8. Did working relationships adhere mainly to these formal procedures, or were more informal patterns of communication predominantly used (eg direct contact, ad hoc informal meetings, etc)?
- (a) If mainly formal: describe any instances or circumstances in which these channels were not used.
- (b) If mainly informal: describe on what basis they occurred (eg ad hoc/as needed meetings, or more routine/regular direct informal contact); and describe the sorts of instances and circumstances in which more formal channels may have been used.
9. If any problems occurred during the design process, how were these dealt with and by whom?
10. Were the design plans established submitted for approval at a higher level in the organisation? YES/NO
- If YES: (a) Who had the job of preparing and submitting plans?
- (b) To whom were the plans submitted for approval?
- (c) What factors were taken into consideration in giving approval for the plans?

(d) Describe any rework of the plans that was involved.

If NO: (a) Describe how any reports were submitted, how frequently, by whom, and in what manner during design.

(b) Describe any limitations on the authority of team members to take decisions concerning the design.

11. Describe the patterns of any communications and coordination between the design team and external groups (eg main contractor, consultants) during design.
12. What formal procedures, if any, were established for liaison with external groups during the design stage (eg briefings, meetings, correspondence, etc)?
13. Did working relationships adhere mainly to those formal procedures, or were more informal patterns of communication predominantly used (eg direct contact, ad hoc informal meetings, etc)?
- (a) If mainly formal: describe any instances or circumstances in which these channels were not used.
- (b) If mainly informal: describe on what basis they occurred (eg ad hoc/as needed meetings, or more routine/regular direct informal contact); and describe the sorts of instances and circumstances in which more formal channels may have been used.
14. If any problems occurred in external dealings during the design stage, how were they dealt with and by whom?
15. Which individual(s)/group(s) performed the role(s) of liaising with external bodies, and with which individual(s)/group(s) did they liaise during design?

Construction Planning Activities

1. How long was the duration of the construction planning stage?
2. Describe the activities that were involved in establishing plans for the project, and the stages at which they occurred.
3. Were these activities 'routine' or specific to this project?
 - (a) If routine: describe the reasons for any divergence from 'normal practice'.
 - (b) If specific: describe 'normal practice' and the reasons for the divergence from it in this case.
4. What were the major considerations taken into account in planning out the work?
5. Were major planning alternatives proposed at any stage? YES/NO
If YES: What choices were made, and why?

The Organisation of Planning Work:

1. Who determined the planning team structure, the selection of personnel, and the assignment of tasks to participants?
2. Was one individual put in charge of the total planning effort? YES/NO
 - (a) If YES: Who was this individual (eg PM) and to whom did they report?
 - (b) If NO: How was the planning team constituted, and to whom did the team report?

3. Where was the organisational and physical location of the project office and groups/organisations providing administrative support during planning? (Enclose organisational chart if available).

4. Which personnel were appointed for, and involved in, establishing a construction plan for the project?
 - (a) From which departments did these personnel originate?
 - (b) Were they seconded to the project team full-time?
 - (c) Upon what basis were personnel selected and appointed?
 - (d) What part did they play in the planning process?
 - (e) To whom did they report and in what ways during planning?
 - (f) Did their involvement continue beyond the planning stage? If so, what was their role?

5. For each individual/group involved in planning, did their respective functional manager(s) play any direct part in supervising their work on the project? YES/NO
 - (a) If YES: describe their involvement.
 - (b) If NO: describe any part they played in providing ongoing support services, training, etc for staff involved in the project team.

6. Describe the patterns of communications and coordination between team members during planning.

7. What formal procedures, if any, were established for liaison between project team members during the planning stage (eg briefings, meetings, etc)?

8. Did working relationships adhere mainly to these formal procedures, or were more informal patterns of communication predominantly used (eg direct contact, ad hoc informal meetings, etc)?
- (a) If mainly formal: describe any instances or circumstances in which these channels were not used.
- (b) If mainly informal: describe on what basis they occurred (eg ad hoc/as needed meetings, or more routine/regular direct informal contact); and describe the sorts of instances and circumstances in which more formal channels may have been used.
9. If any problems occurred during the planning process, how were these dealt with and by whom?
10. Were the construction plans established submitted for approval at a higher level in the organisation? YES/NO
- If YES: (a) Who had the job of preparing and submitting plans?
- (b) To whom were the plans submitted for approval?
- (c) What factors were taken into consideration in giving approval for the plans?
- (d) Describe any rework of the plans that was involved.
- If NO: (a) Describe how any reports were submitted, how frequently, by whom, and in what manner during planning.
- (b) Describe any limitations on the authority of team members to take decisions concerning the plans for the work.
11. Describe the patterns of any communications and coordination between the planning team and external groups (eg design team, subcontractors) during the planning stage.

12. What formal procedures, if any, were established for liaison with external groups during the planning stage (eg briefings, meetings, correspondence, etc)?
13. Did working relationships adhere mainly to those formal procedures, or were more informal patterns of communication predominantly used (eg direct contact, ad hoc informal meetings, etc)?
- (a) If mainly formal: describe any instances or circumstances in which those channels were not used.
- (b) If mainly informal: describe on what basis they occurred (eg ad hoc/as needed meetings, or more routine/regular direct informal contact); and describe the sorts of instances and circumstances in which more formal channels may have been used.
14. If any problems occurred in external dealings during the planning stage, how were they dealt with and by whom?
15. Which individual(s)/group(s) performed the role(s) of liaising with external bodies, and with which individual(s)/group(s) did they liaise during planning?

Construction Activities

1. When did construction on site begin?
2. Do design and construction phases 'overlap' in any way? YES/NO
- If YES: (a) Which design activities were carried over into the construction phase?
- (b) What was the aim of these activities, and how were they likely to influence established plans?

(c) How was undesigned work specified (eg provisional sums)?

- If NO:
- (a) How detailed were the design plans for the work that has to be carried out?
 - (b) Are detailed design plans and specifications subject to review? If so, how?
 - (c) Are they taken as fixed, or left subject to change and alteration as needed?
 - (d) What are the procedures for the change and modification of design specifications; and under what circumstances are changes made?

3. Do construction planning and construction phases 'overlap' in any way? YES/NO

- If YES:
- (a) Which planning/resourcing activities were carried over into the construction phase?
 - (b) What was the aim of these activities, and how were they likely to influence established plans?
 - (c) How was unplanned work specified?

- If NO:
- (a) How detailed were the construction plans for the work that has to be carried out?
 - (b) Are detailed construction plans and schedules subject to review? If so, How?
 - (c) Are they taken as fixed, or left subject to change and alteration as needed?
 - (d) What are the procedures for the change and modification of construction plans/schedules; and under what circumstances are changes made?

4. (a) What procedures are established for obtaining labour for the project (eg recruitment/transfer)?

- (b) What forms the basis for these activities (eg monthly or weekly programme of works), and what other considerations are taken into account?
- 5.
- (a) What procedures are established for resourcing the work on site (eg plant/materials requisition, hire purchase)?
 - (b) What forms the basis for these activities (eg the programme, bill of quantities), and what other considerations are taken into account?
 - (c) Does the contract in any way constrain the choice of types of plant or materials? If so, how?
- 6.
- (a) What procedures are established for contracting third parties (ie subcontractors, suppliers)?
 - (b) What forms the basis for these activities (eg programmes of work), and what other considerations are taken into account?
 - (c) On what basis is the choice of third parties made (eg price, etc)?
 - (d) Does the contract in any way constrain the choice of subcontractor/supplier? If so, how?
7. What is (are) the procedure(s) for monitoring progress against the programme?
- (a) Is the review periodic or ad hoc?
If periodic, specify the time period(s).
If ad hoc, specify the circumstances.
 - (b) What constitute(s) the subject(s), scope and methods of monitoring progress?
 - (c) How is this data collected, processed, distributed and used?
 - (d) How are exceptions dealt with?

8. What is (are) the procedure(s) for monitoring the quality of works against the design?
- (a) Is the review periodic or ad hoc?
If periodic, specify the time period(s).
If ad hoc, specify the circumstances.
 - (b) What constitutes the subject(s), scope and method of inspection/quality control?
 - (c) How is this data collected, processed, distributed and used?
 - (d) How are exceptions dealt with?
9. What is (are) the procedure(s) for the financial monitoring of the work?
- (a) Is the review periodic or ad hoc?
If periodic, specify the time period(s).
If ad hoc, specify the circumstances.
 - (b) What constitutes the subject(s), scope and method of financial monitoring/control?
 - (c) How is this data collected, processed, distributed and used?
 - (d) How are exceptions dealt with?
10. What procedure(s) is (are) established for monitoring resource requirements and resource availability during construction?
- (a) Is the review period or ad hoc?
If periodic, specify the time period(s).
If ad hoc, specify the circumstances.
 - (b) What constitute the subject(s) (eg materials, plant), scope and method(s) of reviewing resource needs?
 - (c) How is this data collected, processed, distributed and used?
 - (d) How are exceptions dealt with?

Construction Organisation

1. Who determined the site team structure, the selection of personnel, and the assignment of tasks to participants?

2. (a) Which personnel continue their involvement from the planning stage, and what are their roles during construction?

(b) Which centralised support services continue to provide administrative support during construction?

3. Was one individual put in charge of the total construction process on site? YES/NO

(a) If YES: who is this individual, and to whom do they report?

(b) If NO: how is the site team constituted, and to whom do members report?

4. Where is the organisational and physical location of the project (site) office and groups/organisations providing administrative support during construction? (Enclose organisation chart if available).

5. Which personnel were appointed to the construction site team?

(a) From where did they originate (eg transferred, seconded, recruited)?

(b) Are they seconded to the site team full-time?

(c) Upon what basis were personnel selected and appointed?

(d) What part do they play in managing the construction process on site?

(e) To whom do they report, and in what ways during construction?

- (f) Were they involved in the project in any way prior to work starting on site? If so, describe how.
- (g) Are they involved for the full duration of construction? Does their involvement continue beyond final completion? If so, what does this involve?
- (h) What part, if any, do other departmental staff (ie functional managers) play in supervising their work/providing support/training, etc, during construction?

6. Are all site personnel directed and supervised by the individual in charge of the team? YES/NO

- If YES:
- (a) Is this individual given full authority to exercise control over the contribution of project team members?
 - (b) If not, describe where control is lacking.
 - (c) Are there any limitations on the authority of that individual to make decisions with regard to the project?
 - (d) Describe these limitations.

- If NO:
- (a) Who is responsible within each department for determining project effort priorities?
 - (b) In what areas do they have authority to take decisions with respect to the project?
 - (c) Describe the limitations on the authority of these individuals to make technical and business decisions with regard to the project.

Construction Planning and Control

- 1. (a) Who is responsible in the construction phase for the detailed planning of the work on site?

- (b) To whom do they report?
 - (c) Which other individuals/groups, if any, are involved in the detailed planning of the work?
 - (d) How are these involved?
- 2.
- (a) Who is responsible in the construction phase for the detailed design/specification of the work on site?
 - (b) To whom do they report?
 - (c) Which other individuals/groups, if any, are involved in the detailed design/specification of the work?
 - (d) How are these involved?
- 3.
- (a) Who is responsible in the construction phase for the allocation and administration of resources (labour, plant, materials, third parties)?
 - (b) To whom do they report?
 - (c) Which other individuals/groups, if any, are involved in the allocation and administration of resources (labour, plant, materials, third parties)?
- 4.
- (a) Who is responsible for identifying and collecting progress performance data?
 - (b) To whom are reports or other progress information submitted, and for what purpose(s)?
 - (c) If exceptions occur, who is responsible for deciding upon an appropriate course of action?
 - (d) Which other individuals/groups are involved in this process of deciding what action is to be taken?
 - (e) What part do they play in this process (eg give instructions, consultation, advice, information, other)?

- (f) Who, if anyone, is responsible for approving any schedule changes?
 - (g) Who is required to act on the basis of decisions reached?
- 5.
- (a) Who is responsible for identifying and collecting quality/technical performance data?
 - (b) To whom are reports or other information submitted, and for what purpose(s)?
 - (c) If exceptions occur, who is responsible for deciding upon an appropriate course of action?
 - (d) Which other individuals/groups are involved in this process of deciding what action is to be taken?
 - (e) What part do they play in this process (eg give instructions, consultation, advice, information, other)?
 - (f) Who, if anyone, is responsible for approving any design specification changes?
 - (g) Who is required to act on the basis of decisions reached?
- 6.
- (a) Who is responsible for identifying and collecting financial performance data?
 - (b) To whom are reports or other information submitted, and for what purpose(s)?
 - (c) If exceptions occur, who is responsible for deciding upon an appropriate course of action?
 - (d) Which other individuals/groups are involved in this process of deciding what action is to be taken?
 - (e) What part do they play in this process (eg give instructions, consultation, advice, information, other)?
 - (f) Who, if anyone, is responsible for approving any financial changes?

7.
 - (a) Who is responsible for identifying and collecting data on resource usage?
 - (b) To whom are reports or other information submitted, and for what purpose(s)?
 - (c) If problems in obtaining resources occur, who is responsible for deciding upon an appropriate course of action?
 - (d) Which other individuals/groups are involved in this process of deciding what action is to be taken?
 - (e) What part do they play in this process (eg give advice, instructions, consultation, advice, information, other)?
 - (f) Who, if anyone, is responsible for approving any changes to resource schedules?
 - (g) Who is required to act on the basis of decisions reached?

8. Describe the patterns of communication and coordination between team members during construction.

9. What formal procedures, if any, are established for liaison between site staff during construction (eg briefings, meetings, etc)?

10. Do working relationships adhere mainly to these formal procedures, or are more informal patterns of communication predominantly used (eg direct contact, ad hoc informal meetings, etc)?
 - (a) If mainly formal: describe any instances or circumstances in which these channels are not used.
 - (b) If mainly informal: describe on what basis they occur (eg ad hoc/as needed meetings, or more routine/regular direct informal contact); and describe the sorts of instances and circumstances in which more formal channels may be used.

11. If any problems occur within the team, how are these dealt with and by whom?
12. Describe the patterns of communications and coordination mechanisms between main contractor and external parties (designers, subcontractors) during construction.
13. What formal procedures, if any, are established for liaison with external groups during the construction stage (eg briefings, meetings, correspondence, etc)?
14. Do working relationships adhere mainly to these formal procedures, or are more informal patterns of communication predominantly used (eg direct contact, ad hoc informal meetings and discussions, etc)?
 - (a) If mainly formal: describe any instances or circumstances in which these channels are not used.
 - (b) If mainly informal: describe on what basis they occur (eg ad hoc/as needed meetings, or more routine/regular direct informal contact); and describe the sorts of instances and circumstances in which more formal channels may be used.
15. If any problems occur in external dealings during the construction stage, how are they dealt with, and by whom?
16. For each organisation, which individual(s)/group(s) perform the role(s) or liaising with external groups, and with which individual(s)/group(s) do they liaise during construction?

APPENDIX B

INTERVIEW SCHEDULE

(Note: This schedule formed the basis for loosely-structured interviews held with those involved on site. The questions were left broad and open-ended, and prompts were used to obtain more detailed responses. These prompts varied a good deal due to variation in the lines of response. And the order of asking these broad questions also varied as a function of the particular direction the conversation took. These questions should, therefore, be taken only as broadly indicative of the issues addressed. While these questions were asked, the manner and sequence of asking and the form of the response, made the process of interviewing highly idiosyncratic. The interviews were recorded manually, in the form of field notes.)

1. Can you describe your own job and your role on this project?
2. Have you had previous experience of doing this type of work before?
3. How long have you been with the company, and what sort of experience have you had working for the firm?
4. Can you describe the type of work involved on this project that you are responsible for?
5. Can you describe the parts played by yourself and other members of your team in managing the work on this site?
6. Can you describe the direct dealings you have on a day to day basis with other members of your own team?
7. Can you describe any direct dealings that you or other members of the team have with your head office staff?
8. How would you describe the way in which this project is run and managed: for example, is the site a 'self-contained one', are dealings formal or fairly informal, is everything written down, and so on?
9. Can you describe any direct dealings that you or other members of the team have with the subcontractors employed on site?
10. How would you describe the way in which these dealings are conducted (eg formal/informal)?

11. Can you describe any direct dealings that you or other members of the team have with members of the design team/main contractor's team on site?
12. Do you (or these others) deal directly with staff at site level? Do you have any dealings at all with staff at a 'head office' level (in other organisations)?
13. How would you describe the way in which these dealings are conducted (eg formally/informally)?
14. How detailed and appropriate do you think have been the design plans established for the work (ie drawings, specifications)? Have the plans changed at all during construction?
15. How detailed and appropriate do you think have been the construction plans (ie programme, estimate) drawn up for the work? Have the plans changed at all during construction?
16. What part do you personally play in planning out in detail the work to be done on site?
17. Who do you mainly deal with in drawing up these plans?
18. What part do you personally play in monitoring the work that goes on on site?
19. Who do you mainly deal with in monitoring the work on site?

20. Are you satisfied with the performance levels achieved on this project?
21. What sorts of problems, if any, have cropped up in performing the work on site, and how have they been dealt with?
22. How do you think the management of this project has been handled?
23. How do you think the design team/main contractor have handled their approach to the project?
24. What sorts of implications, if any, has performance on this project had for your firm/organisation?

APPENDIX C:

BIBLIOGRAPHY

- ADRIAN J J (1981), 'CM: The Construction Management Process',
Virginia; Reston
- AIKEN M and ALFORD R (1970), 'Community Structure and Innovation:
The Case of Public Housing', American Political Science Review,
vol 64, 843-864
- AIKEN M and HAGE J (1968), 'Organisational Interdependence and
Intra-organisational Structure', American Sociological Review,
vol 33, 912-929
- ALDRICH H E (1971), 'Organisational Boundaries and Interorganisational
Conflict', Human Relations, vol 24, 279-293
- ALDRICH H E (1972), 'Technology and Organisational Structure: A
Re-examination of the Findings of the Aston Group', Administrative
Science Quarterly, vol 17(1), 26-43
- ALDRICH H E (1979), 'Organisations and Environments', Englewood Cliff
N J; Prentice-Hall
- ALLEN T J and COHEN S (1969), 'Information Flow in Research and
Development Laboratories', Administrative Science Quarterly,
vol 14(1), 12-20
- AQUA GROUP (1975), 'Which Builder?: Tendering and Contractual
Arrangements', London; Aqua
- AQUA GROUP (1979), 'Contract Administration for Architects and Quantity
Surveyors', London; Granada, 1979
- ARDITI D and KUTAY A (1981), 'Organisational and Contextual
Characteristics of Construction Firms', ppD.2.94-109 in CIOB
Proceedings, W65(3) Dublin
- ARGYRIS C (1967), 'Today's Problems with Tomorrow's Organisations',
Journal of Management Studies, vol 4(1), 32-55
- ARGYRIS C (1971), 'Management and Organisational Development', New York;
McGraw-Hill
- ARGYRIS C (1972), 'The Applicability of Organisational Sociology',
London; Cambridge UP
- BALES R F (1950), 'A Set of Categories for the Analysis of Small
Group Interaction', American Sociological Review, vol 15, 257-263
- BALES R F and SLATER P E (1955), 'Role Differentiation in Small
Decision-Making Groups', in T PARSONS and R F BALES (eds),
'Family Socialisation and Interaction Processes', New York; Free Press

- BARTLETT (1980), Proceedings, Bartlett Summer School, Bartlett School of Architecture and Planning, University College, London; July 1980
- BANWELL (1964), 'The Placing and Management of Contracts for Building and Civil Engineering Work', London; HMSO
- BARRIE D S and PAULSON B C (1978), 'Professional Construction Management', New York; McGraw Hill
- BENNIS W G (1966), 'Changing Organisations', Journal of Applied Behavioural Science, vol 2(3), 247-263
- BERGEN S A (1975), 'The New Product Matrix', R & D Management, vol 5(2), 149-152
- BIRRELL G (1981), 'The Informal Organisation which Manages the Construction Process', pp B.1.201-211, in CIOB, Proceedings W65(3), Dublin
- BISHOP D (1972), 'Productivity in the Building Industry', The Philosophical Transactions of the Royal Society, London, A27(1229), 533-563
- BLAKE R R and MOUTON J S (1964), 'The Managerial Grid', Houston; Gulf
- BLAU J R and McKINLEY W (1979), 'Ideas, Complexity and Innovation', Administrative Science Quarterly, vol 24(2), 200-219
- BLAU P M (1964), 'Exchange and Power in Social Life', New York; Wiley
- BLAU P M (1970), 'Decentralisation in Bureaucracies', in MN ZALD (ed) 'Power in Organisations', Nashville Tenn; Vanderbilt UP
- BLAU P M, HEYDEBRAND W and STAUFFER R E (1966), 'The Structure of Small Bureaucracies', American Sociological Review, vol 31(2), 179-191
- BLAU P M and SCHOENHERR R A (1970), 'A Formal Theory of Differentiation in Organisations', American Sociological Review, vol 35(2), 201-218
- BLAU P M and SCHOENHERR R A (1971), 'The Structure of Organisations', New York; Basic Books
- BLAU P M and SCOTT W R (1962), 'Formal Organisations', London; Routledge and Kegan Paul
- BONG-GON P S and SHULL F A (1978), 'Matrix Organisation and Associated Planning Behaviours: Conceptual Considerations', Management International Review, vol 18(4), 25-32
- BORCHERDING J D (1977), 'Participative Decision Making in Construction', ASCE Journal of the Construction Division, vol 103(4), 567-576
- BORCHERDING J D and GARNER D F (1981), 'Work Force Motivation and Productivity on Large Jobs', ASCE Journal of the Construction Division, vol 107(3), 443-453

- BORCHERDING J D, SEBASTIAN S J and SAMUELSON N M (1980), 'Improving Motivation and Productivity on Large Projects', ASCE Journal of the Construction Division, vol 106(1), 73-89
- BOWERS D G and SEASHORE S E (1966), 'Predicting Organisational Effectiveness with a Four-Factor Theory of Leadership', Administrative Science Quarterly, vol 11, 238-263
- BRAVERMAN H (1974), 'Labour and Monopoly Capital', New York
- BRAYFIELD A H and CROCKETT W H (1955), 'Employee Attitudes and Employee Performance', Psychological Bulletin, vol 52(5), 415-422
- BRESNEN M J, BRYMAN A E, BEARDSWORTH A D, FORD J R and KEIL E T (1986), 'The Leader Orientation of Construction Site Managers', ASCE Journal of Construction Engineering and Management, IN PRESS
- BRESNEN M J, BRYMAN A E, FORD J R, KEIL E T, BEARDSWORTH A D, JEPSON M A, WRAY K (1984), 'Effective Construction Site Management: A Review', ASCE Journal of Construction Engineering and Management, vol 110(4), 420-436
- BRESNEN M J, WRAY K, BRYMAN A E, BEARDSWORTH A D, FORD J R and KEIL E T (1985), 'The Flexibility of Recruitment in the Construction Industry: Formalisation or Re-casualisation?', Sociology, vol 19(1), 108-124
- BRIDGES E M, DOYLE W J and MAHAN D J (1968), 'Effects of Hierarchical Differentiation on Group Productivity, Efficiency and Risk-Taking', Administrative Science Quarterly, vol 13(3), 305-319
- BROUGHTON H F (1965), 'Economic Site Organisation and Building Supervision', London; E & F N Spon Ltd
- BROWN W (1966), 'Explorations in Management' (2nd ed), London; Pelican
- BROWN W (1971), 'Organisation', London; Heineman
- BRYANT D T, MACKENZIE M R and AMOS W (1969), 'The Role of the Client in Building', Doc no IOR/335/2, Tavistock Institute of Human Relations; London
- BRYMAN A E (1976), 'The Debate about Quantitative and Qualitative Research: A Question of Method or Epistemology?', British Journal of Sociology, vol 35(1), 75-92
- BRYMAN A E (1986), 'Leadership and Organisations', London; Routledge and Kegan Paul
- BRYMAN A E, BRESNEN M J, BEARDSWORTH A D, FORD J R, and KEIL E T (1986), 'The Concept of the Temporary System: The Case of the Construction Project', Research in the Sociology of Organisations, vol 5, IN PRESS

- BULMER M (1979), 'Concepts in the Analysis of Qualitative Data', Sociological Review, vol 27(4), 651-677
- BURGESS R A (1979), 'Management in the Construction Industry', London; MacMillan
- BURMAN P J (1972), 'Precedence Networks for Project Planning and Control', London; McGraw-Hill
- BURNS T (1963), 'Mechanistic and Organismic Structures', pp40-51 in D S PUGH et al (eds), 'Organisation Theory: Selected Readings', Middx; Penguin, 1971
- BURNS T and STALKER G M (1966), 'The Management of Innovation', London; Tavistock
- CALVERT R E (1981), 'Introduction to Building Management' (4th edn) London; Butterworth
- CAMPINOS-DUBERNET M (1985), 'The Rationalisation of Labour in the Construction Industry: An Example of the Limits of Orthodox Taylorism', paper presented at seminar on 'Training in Construction and the Construction Labour Process', Bartlett School of Architecture and Planning, University College, London, 19 April 1985
- CAPLOW T (1964), 'Principles of Organisation', New York; Harcourt Brace Jovanovich
- CARTER J (1972), 'Management Contracting', Architects Journal 13 Feb 1972
- CARTWRIGHT D (1965), 'Influence, Leadership and Control', in J G MARCH (ed) 'Handbook of Organisations', Chicago; Rand McNally, 1965
- CARTWRIGHT D and ZANDER A, ed (1960), 'Group Dynamics: Research and Theory', (2nd ed), Evanston, Ill; Row Peterson
- CHANDLER A D (1962), 'Strategy and Structure', Cambridge, Mass; MIT Press
- CHARTERED INSTITUTE OF BUILDING (1978), Proceedings W65(2): 'Organisation and Management of Construction', Haifa, Israel, Oct 31-Nov 2
- CHARTERED INSTITUTE OF BUILDING (1981), Proceedings: W65(3): 'Organisation and Management of Construction', Dublin, Ireland, 6-8 July
- CHERNS A B and BRYANT D T (1984), 'Studying the Client's Role in Construction Management', Construction Management and Economics, vol 2, 177-184
- CHILD J (1972), 'Organisational Structure, Environment and Performance: The Role of Strategic Choice', Sociology, vol 6(1), 1-22

- CHILD J (1973), 'Predicting and Understanding Organisational Structure', Administrative Science Quarterly, vol 18, 168-185
- CHILD J and MANSFIELD R (1972), 'Technology, Size and Organisational Structure', Sociology, vol 6(3), 369-393
- CLARK B (1965), 'Interorganisational Patterns in Education', Administrative Science Quarterly, vol 10(3), 224-237
- CLARK P A (1972), 'Organisational Design: Theory and Practice', London; Tavistock
- CLELAND D I and KING W R (1975), 'Systems Analysis and Project Management', London; McGraw-Hill
- CLOUGH R H and SEARS G A (1979), 'Construction Project Management', New York; Wiley
- COLCLOUGH J R (1975), 'The Standard Form of Building Contract', in P A HARLOW (ed) 'The Practice of Site Management' (vol 1, 2nd ed), Ascot; Institute of Building
- COOK K S (1977), 'Exchange and Power in Networks of Interorganisational Relations', Sociological Quarterly, vol 18(1), 62-82
- CRICHTON C (1966), 'Interdependence and Uncertainty; A Study of the Building Industry', London; Tavistock
- CROZIER M (1964), 'The Bureaucratic Phenomenon', London; Tavistock
- CYERT R M and MARCH J G (1963), 'A Behavioural Theory of the Firm', Englewood-Cliffs, NJ; Prentice-Hall
- DAFT R L and BRADSHAW P J (1980), 'The Process of Horizontal Differentiation: Two Models', Administrative Science Quarterly vol 25(3), 441-456
- DALTON M (1959), 'Men Who Manage', New York; Wiley
- DANSERAU F, GRAEN G and HAGA W J (1975), 'A Vertical Dyad Linkage Approach to Leadership within Formal Organisations', Organisational Behaviour and Human Performance, vol 13, 46-78
- DAVIS S M (1974), 'Two Models of Organisation: Unity of Command vs Balance of Power', Sloan Management Review, vol 16(1), 29-40
- DAVIS S M and LAWRENCE P R (1978), 'Problems of Matrix Organisation', Harvard Business Review, vol 56(3), 131-143
- DEHM A (1973), 'Turnkey Power Stations - Business Methods and Project Organisation', Brown Boveri Review, vol 60(6), 269-271

- DEWAR R D and HAGE J (1978), 'Size, Technology, Complexity and Structural Differentiation: Toward a Theoretical Synthesis', Administrative Science Quarterly, vol 23(1), 111-136
- DRUCKER P (1973), 'The Practice of Management', New York; Harper Row
- DRUCKER P F (1974), 'New Templates for Today's Organisations', Harvard Business Review, vol 52(Jan/Feb), 45-54
- DUBIN R (1979), 'Metaphors of Leadership: An Overview', Ch 13 in J G HUNT and L L LARSON (eds), 'Crosscurrents in Leadership', Carbondale, Ill; S Illinois UP, 1979
- DUNCAN R B (1972), 'Characteristics of Organisational Environments and Perceived Environmental Uncertainty', Administrative Science Quarterly, vol 17(3), 313-327
- DUNCAN R B (1973), 'Multiple Decision-Making Structures in Adapting to Environmental Uncertainty: The Impact on Organisational Effectiveness', Human Relations, vol 26(3), 273-291
- DUNNE E J (1978), 'Influence Sources of Project and Functional Managers in Matrix Organisation', Academy of Management Journal, vol 21(1), 135-140
- ECCLES A J (1975), 'Serving Two Masters in the Modern Organisation', Management Decision, vol 12(5), 288-299
- ECONOMIST INTELLIGENCE UNIT REPORT (1978), 'Public Ownership in the Construction Industries', London; EIU, June 1978
- EDMEADES D H (1972), 'The Construction Site: A Study of Site Organisation and New Concepts in Operational Control', London; Pitman
- EGUCHI T (1981), 'Four Levels of Organisation Phenomena in the Construction Industry - A Conceptual Framework and a Few Aspects of Recent Movements in Japan', pp D.2.49-61 in CIOB, Proceedings, W65(3), Dublin
- EMERSON R M (1962), 'Power-Dependence Relations', American Sociological Review, vol 27, 31-41
- EMERY F E (1969), 'Systems Thinking', London; Penguin
- EMERY F E and TRIST E L (1965), 'The Causal Texture of Organisational Environments', Human Relations, vol 18(1), 21-32
- EMMERSON H (1962), 'A Survey of Problems before the Construction Industries', Ministry of Works Report; London; HMSO

- ESLAND G and SALAMAN G, eds (1980), 'The Politics of Work and Occupations', Open University Press
- ESLAND G, SALAMAN G and SPEAKMAN M A, eds (1975), 'People and Work', Open University Press
- ETZIONI A (1965),, 'Dual Leadership in Complex Organisations', American Sociological Review, vol 30(5), 688-698
- ETZIONI A ed (1969), 'A Sociological Reader on Complex Organisations', (2nd ed), New York; Holt, Reinhart & Winston
- EVAN W (1966), 'The Organisation Set: Toward a Theory of Interorganisational Relations', in J THOMPSON (ed), 'Approaches to Organisational Design', Pittsburgh; Pittsburgh UP, 1966
- EVAN W M, ed (1976), 'Interorganisational Relations', London; Penguin
- EYRING H B (1966), 'Some Sources of Uncertainty and their Consequences in Engineering Design Projects', IEEE Transactions on Engineering Management, vol 13, 167-180
- FAILES G E (1977), 'Better Project Organisation Through Coordination Management', Management Conference, Institute of Engineers, Newcastle, Australia, 19-20 May 1977, pp90-93
- FELLOWS R F (1981), 'The 1980 JCT Form of Building Contract', London; MacMillan
- FESTINGER L and LAWRENCE (1954),
- FIEDLER F E (1967), 'A Theory of Leadership Effectiveness', New York; McGraw-Hill
- FIEDLER F E (1972), 'Personality, Motivational Systems and Behaviour of High and Low LPC Persons', Human Relations, vol 35, 391-412
- FIEDLER F E (1978), 'The Contingency Model and the Dynamics of the Leadership Process', Advances in Experimental Social Psychology, vol 11, 59-112
- FIEDLER F E and CHEMERS M M (1984), 'Improving Leadership Effectiveness: The Leader Match Concept', (2nd ed), New York; Wiley
- FILLEY A C and HOUSE R J (1969), 'Managerial Processes and Organisational Behaviour', Glenview, Ill.; Scott Foresman & Co
- FLEISHMAN E A (1973), 'Twenty Years of Consideration and Initiating Structure', in E A FLEISHMAN and J G HUNT (eds) 'Current Developments in the Study of Leadership', Carbondale; Southern Ill UP, 1973

- FLEMING M C (1980), 'Construction', in P S JOHNSON (ed) 'The Structure of British Industry', London; Granada, 1980
- FOA U G, MITCHELL T R and FIEDLER F E (1971), 'Differentiation Matching', Behavioural Science, vol 16, 130-142
- FORSTER G (1981), 'Construction Site Management', London; Longmans
- FREEMAN I L and BENTLEY M J C (1980), 'Quality Control in Construction on Site - Some Observations of Current UK Practice', Building Research Establishment, PD8/80, Department of the Environment, January 1980
- FRENCH J R P and RAVEN B (1959), 'The Bases of Social Power', in D CARTWRIGHT (ed), 'Studies in Social Power', Ann Arbour; Michigan Institute for Social Research, 1959
- FRIEND J K, POWER J M and YEWLETT C J L (1974), 'Public Planning: The Inter-Corporate Dimension', London; Tavistock
- GALBRAITH J R (1971), 'Matrix Organisational Designs - How to Combine Functional and Project Forms', Business Horizons, vol 14(1), 29-40
- GALBRAITH J R (1973), 'Designing Complex Organisations', Reading, Mass; Addison-Wesley
- GALBRAITH J R (1977), 'Organisation Design', Reading, Mass; Addison-Wesley
- GIBB C A ed (1969), 'Leadership', London; Penguin
- GOGGIN W C (1974), 'How the Multi Dimensional Structure Works at Dow Corning', Harvard Business Review, vol 52(1), 54-65
- GOULDNER A (1959), 'Reciprocity and Autonomy in Functional Theory', in L GROSS (ed), 'Symposium on Sociological Theory', New York; Harper and Row
- GRAEN G and CASHMAN J E (1975), 'A Role Making Model of Leadership in Formal Organisations: A Developmental Approach', in J G HUNT and L L LARSON (eds), 'Leadership Frontiers', Carbondale, Ill; S Illinois UP, 1975
- GULICK L and URWICK L F eds (1937), 'Papers on the Sciences of Administration', New York, IPA, Columbia Univ
- GUNZ H P and PEARSON A W (1977), 'Introduction of a Matrix Structure into an R & D Establishment', R & D Management, vol 7(3), 173-183

- HAGE J (1980), 'Theories of Organisations', New York; Wiley
- HAGE J and AIKEN M (1967a), 'Relationship of Centralisation to Other Structural Properties', Administrative Science Quarterly, vol 12(1), 72-91
- HAGE J and AIKEN M (1967b), 'Programme Change and Organisational Properties', American Journal of Sociology, vol 75(2), 503-519
- HAGE J and AIKEN M (1969), 'Routine Technology, Social Structure and Organisational Goals', Administrative Science Quarterly, vol 14(3), 366-377
- HALPIN A W and WINER B J (1957), 'A Factorial Study of the Leader Behaviour Descriptions', Ch 3, in R M STOGDILL and A E COONS (eds) 'Leader Behaviour: Its Description and Measurement', Columbus, Ohio; Ohio State UP
- HALSEY R and MERGERISON C J (1978), 'Managing a Large Construction Site', Management Decision, vol 16(4), 246
- HALL R H (1962), 'Intraorganisational Structural Variation: Application of the Bureaucratic Model', Administrative Science Quarterly, vol 7(3), 295-308
- HALL R H (1968), 'Professionalisation and Bureaucratisation', American Sociological Review, vol 33(1), 92-104
- HALL R H (1982), 'Organisations: Structure and Process', Englewood Cliffs, NJ; Prentice-Hall
- HALL R H, CLARK J P, GIORDANO P C, JOHNSON P V and VAN ROEKEL M (1977), 'Patterns of Interorganisational Relationships', Administrative Science Quarterly, vol 22(3), 457-474
- HALL R H, CLARK J P, GIORDANO P C, JOHNSON P V and VAN ROEKEL M (1978), 'Interorganisational Coordination in the Delivery of Human Services', in L KARPIK (ed) 'Organisation and Environment: Theory, Issues and Reality', California; Sage, 1978
- HALL R H, HAAS J E and JOHNSON N (1967a), 'An Examination of the Blau-Scott and Etzioni Typologies', Administrative Science Quarterly, vol 12(2), 118-139
- HALL R H, HAAS J E and JOHNSON N (1967b), 'Organisational Size, Complexity and Formalisation', American Sociological Review, vol 32(6), 903-912
- HALL R H and TITTLE C R (1966), 'Bureaucracy and its Correlates', American Journal of Sociology, vol 72(3), 267-272

- HANDY C B (1976), 'Understanding Organisations', London; Penguin
- HARRIS F and McCAFFER R (1983), 'Modern Construction Management', (2nd ed), London; Granada
- HATCHETT M (1971), 'Site Management - A Time for Rethinking', Site Management Information Paper No 41, London; Institute of Building
- HEMPHILL J K and COONS A E (1957), 'Development of the Leader Behaviour Description Questionnaire', in R M STOGDILL and A E COONS (eds) 'Leader Behaviour: Its Description and Measurement', Columbus, Ohio; Bureau of Business Research, 1957
- HENDRY W D (1975), 'A General Guide to Matrix Management', Personnel Review, vol 4(2), 33-39
- HERBST P G (1974), 'Socio-Technical Design', London; Tavistock
- HERZBERG F, MAUSNER B and SYNDERMAN B (1959), 'The Motivation to Work', New York; Wiley
- HICKSON D J, HININGS C R, LEE C A, SCHNECK R E and PENNINGS J M (1971), 'A Strategic Contingencies Theory of Intra-Organisational Power', Administrative Science Quarterly, vol 16, 216-229
- HICKSON D J, PUGH D J and PHEYSEY D C (1969), 'Operational Technology and Organisational Structure: An Empirical Reappraisal', Administrative Science Quarterly, vol 14(3), 378-397
- HIGGIN G and JESSOP N (1965), 'Communications in the Building Industry', London; Tavistock
- HJERN B and PORTER D O (1980), 'Implementation Structures: A New Unit of Administrative Analysis', Organisation Studies, vol 2(3), 211-227
- HOLLANDER E P and JULIAN J W (1969), 'Contemporary Trends in the Analysis of Leadership Processes', Psychological Bulletin, vol 71(5), 387-397
- HOMANS G C (1958), 'Social Behaviour as Exchange', American Journal of Sociology, vol 63(3), 597-608
- HOUSE R J and DESSLER G (1974), 'The Path-Goal Theory of Leadership: Some Post Hoc and A Priori Tests', in J G HUNT and L L LARSON (eds), 'Contingency Approaches to Leadership', Carbondale; S Illinois UP, 1974
- HOUSE R J and MITCHELL T R (1974), 'Path-goal Theory of Leadership', Journal of Contemporary Business, vol 3(4), 81-97

- HOUSE'S GUIDE TO THE CONSTRUCTION INDUSTRY', (7th ed, 1979-80),
London, Whitefriars Press, 1981
- HULL F and HAGE J (1982), 'Organising for Innovation: Beyond Burns
and Stalkers' Organic Type', Sociology, vol 16(4), 564-577
- HUTTON G (1972), 'Thinking About Organisation', London; Tavistock
- INSTITUTE OF BUILDING (1979), 'Project Management in Building',
IOB occ paper No 20, 1979
- INSTITUTE OF CIVIL ENGINEERS (1979), 'Civil Engineering Procedure',
London; ICE
- INTERNET CONGRESS (6), (1979), Vol 4: 'Organisational Concepts of
Project Management', Proceedings (ed R W GUTSCH, H RESCHKE
and H SCHELLE), Garmisch-Partenkirchen, Dusseldorf, WG, 1979
- ISAAC P C G, ed (1971), 'Management in Civil Engineering', Newcastle-
upon-Tyne; Oriel
- IRELAND V and STRETTON A (1981), 'Education for Project Management',
pp B.2.65-78 in CIOB Proceedings W65(3), Dublin
- IRWIG H G (1977), 'Project and Functional Managers in Construction:
A Comparison Using a Critical Functions Approach', in PROJECT
MANAGEMENT INSTITUTE, Proceedings, Chicago, Ill, 1977, vol D,
55-68
- JACOBS D (1974), 'Dependence and Vulnerability: An Exchange Approach
to the Control of Organisations', Administrative Science Quarterly,
vol 19, 45-59
- JACQUES E (1976), 'A General Theory of Bureaucracy', London; Heinemann
- JOHNSON T J (1981), 'Professions and Power', London; MacMillan
- KAHN R L, WOLFE D M, QUINN R P, SNOEK J D, and ROSENTHAL R A (1964),
'Organisational Stress: Studies in Role Conflict and Ambiguity',
New York; Wiley
- KANNO M (1968), 'The Effects on Communication between Laboratories
and Plants of the Transfer of R & D Personnel', Unpublished
dissertation; MIT Press
- KATZ D and KAHN R L (1951), 'Human Organisation and Worker Motivation',
in L R TRIPP (ed) 'Industrial Productivity' Madison, Wisc;
IRRA, 1951
- KAVANAGH T C, MULLER F and O'BRIEN J J (1978), 'Construction
Management', London; McGraw-Hill

- KEATING D (1969), 'Law and Practice of Building Contracts' (3rd ed), London; Sweet and Maxwell
- KEATING D (1978), 'Building Contracts' (4th ed), London; Sweet and Maxwell
- KERR S and JERMIER J M (1978), 'Substitutes for Leadership: their Meaning and Measurement', Organisational Behaviour and Human Performance, vol 22, 375-403
- KERR S, SCHRIESHEIM C A, MURPHY C J and STOGDILL R M (1974), 'Toward a contingency theory of leadership based upon the consideration and initiating structure literature', Organisational Behaviour and Human Performance, vol 12, 62-82
- KHANDWALLA P N (1972), 'Environment and its Impact on the Organisation', International Studies of Management and Organisation, vol 2(3), 297-313
- KINGDON D R (1973), 'Matrix Organisation', London; Tavistock
- KNIGHT K (1976-7), 'Matrix Organisation - A Review', Journal of Management Studies, vol 13-14, 111-130
- KNIGHT K ed (1977), 'Matrix Management', London; Gower Press
- KNIGHT K (1977b), 'Responsibility and Authority in Matrix Organisation - or is Ambiguity a Good Thing?', R & D Management, vol 7(3), 180-186
- KOCHAN T A (1975), 'The Determinants of Power of Boundary Units in an Interorganisational Bargaining Relation', Administrative Science Quarterly, vol 20(3), 434 -
- KOCHAN T A, HUBER G P and CUMMINGS L C (1975), 'Determinants of Interorganisational Conflicts in Collective Bargaining in the Public Sector', Administrative Science Quarterly, vol 20(1), 10-23
- KOONTZ H and O'DONNELL C (1980), 'Management' New York; McGraw-Hill
- LANSLEY P (1981), 'The Flexibility of Construction Management', pp D.2.110-122 in CIOB Proceedings, W65(3) Dublin
- LARSON L L, HUNT J G and OSBORN R N (1976), 'The great hi-hi leader behaviour myth: a lesson from Occan's razor', Academy of Management Journal, vol 19, 628-641
- LAWLER E E and PORTER L W (1967), 'The Effect of Performance on Job Satisfaction', Industrial Relations, vol 7(3), 20-28

- LAWRENCE P R and LORSCH J W (1967), 'Organisation and Environment', Cambridge, Mass; Harvard UP
- LAWRENCE P R and LORSCH J W (1967b), 'A New Management Job: The Integrator', Harvard Business Review, vol 45 (Nov/Dec), 142-152
- LEIFER R and HUBER G P (1977), 'Relations Among Perceived Environmental Uncertainty, Organisational Structure and Boundary Spanning Behaviour', Administrative Science Quarterly, vol 22(2), 235-247
- LEVINE S and WHITE P E (1961), 'Exchange as a Conceptual Framework for the Study of Interorganisational Relationships', Administrative Science Quarterly, vol 5(1), 583-610
- LIKERT R (1961), 'New Patterns of Management', New York; McGraw-Hill
- LIKERT R (1967), 'Human Organisation', New York; McGraw-Hill
- LIMERICK D (1976a), 'Authority: An Axis of Leader Role Differentiation', Psychologia Africana, vol 16(3), 153-172
- LIMERICK D (1976), 'Authority Relations in Different Organisational Systems', Academy of Management Review, Oct 1976, 56-68
- LITWAK E and HYLTON L (1962), 'Interorganisational Analysis: An Hypothesis on coordinating Agencies', Administrative Science Quarterly, vol 6(1), 395-420
- LORSCH J W and LAWRENCE P R (1972), 'Managing Group and Intergroup Relations', Chicago, Ill; Irwin
- LOWIN A and CRAIG N J (1968), 'The Influence of Level of Performance on Managerial Style: An Experimental Object-Lesson in the Ambiguity of Correlational Data', Organisational Behaviour and Human Performance, vol 3, 440-458
- LUMLEY R (1980), 'A Modified Rules approach to Workplace Industrial Relations', Industrial Relations Journal, vol 10, 49-
- MAIER N R F (1967), 'Assets and Liabilities in Group Problem-Solving: the Need for an Integrative Function', Psychological Review, vol 74(4), 239-249
- MANSFIELD R (1973), 'Bureaucracy and Centralisation: An Examination of Organisational Structure', Administrative Science Quarterly, vol 18(4), 77-88
- MARCH J G ed (1965), 'Handbook of Organisations', Chicago; Rand McNally
- MARCH J G and SIMON H A (1958), 'Organisations', New York; Wiley

- MARQUIS D (1969), 'Ways of Organising Projects', Innovation, vol 5, 26-33
- MARRETT C B (1971), 'On the Specification of Interorganisational Dimensions', Sociology and Social Research, vol 56(1), 83-99
- MASLOW A H (1943), 'A Theory of Human Motivation', Psychological Review, vol 50, 370-396
- McLAUGHLIN W A and HANDA V K (1981), 'The Construction Process - A Subjective Analysis', pp A.1.321-334 in CIOB Proceedings, W65(3), Dublin
- MEE J F (1964), 'Matrix Organisation', Business Horizons, Summer 1964, 70-72
- MELCHER A J (1977), 'Leadership Models and Research Approaches', Ch 6, in J G HUNT and L L LARSON (eds), 'Leadership: The Cutting Edge', Carbondale Ill; S Illinois UP, 1977
- MELCHER R D (1967), 'Roles and Relationships: Clarifying the Manager's Job', Personnel, vol 44(3)
- MELCHERS R E (1977), 'The Influence of Organisation on Project Implementation', ASCE Journal of the Construction Division, vol 103(4), 611-625
- MILLER E J (1959), 'Technology, Territory and Time: The Internal Differentiation of Complex Production Systems', Human Relations, vol 12 (Aug), 243-272
- MILLER E J and RICE A K (1967), 'Systems of Organisation', London; Tavistock
- MIN DLIN S E and ALDRICH H E (1975), 'Interorganisational Dependence: A Review of the Concept and A Re-examination of the Aston Group Findings', Administrative Science Quarterly, vol 20 (2), 382-392
- MINTZBERG H (1973), 'The Nature of Managerial Work', New York; Harper and Row
- MINTZBERG H (1979), 'The Structuring of Organisations', Englewood Cliffs, NJ; Prentice-Hall
- MOLNAR J J and ROGERS D L (1979), 'A Comparative Model of Interorganisational Conflict', Administrative Science Quarterly, vol 24(3), 405-424
- MORRIS P W G (1972), 'A Study of Selected Building Projects in the Context of Theories of Organisation', UMIST: Unpublished PhD Thesis

- MORRIS P W G (1973), 'An Organisational Analysis of Project Management in the Building Industry', Building International, vol 6, 595-615
- NEDO (1970), 'Large Industrial Sites', London; HMSO
- NEDO (1976), 'The Professions in Construction', London; HMSO
- NEDO (1978), 'How Flexible is Construction', London; HMSO
- NEGANDI A R, ed (1980), 'Interorganisation Theory', Illinois; Kent State UP
- NEWMAN D (1973), 'Organisation Design', London; Arnold
- NEWPORT W M (1969), 'The Interdepartmental Transfer: an Integrative Strategy', Unpublished dissertation, MIT Press
- NYSTROM P C (1978), 'Managers and the hi-hi Leader Myth', Academy of Management Journal, 21, 325-331
- OUCHI W G (1980), 'Markets, Bureaucracies and Clans', Administrative Science Quarterly, vol 25, 129-141
- PARSONS T (1960), 'Structure and Process in Modern Societies', New York; Free Press
- PATERSON D D (1975), 'Project Management and the Engineer', Proceedings of the Institute of Civil Engineers, vol 58(1), 205-211
- PATTERSON T T (1966), 'Management Theory', London; Business Publications
- PELZ D C (1952), 'Influence : a Key to Effective Leadership in the First-Line Supervisor', Personnel, vol 29, 209-217
- PENNINGS J M (1973), 'Measures of Organisational Structures: A Methodological Note', American Journal of Sociology, vol 79(3), 686-704
- PENNINGS J (1976), 'Cooperation and Conflict Between Interdependent Organisations',. in W J BUCK (ed) 'A Handbook of Organisational Design', Amsterdam
- PERHAM J (1970), 'Matrix Management: a Tough Game to Play', Dun's Review, Aug 1970, 31-34
- PERROW C (1961), 'The Analysis of Goals in Complex Organisations', American Sociological Review, vol 26(6), 688-699

- PERROW C (1965), 'Hospitals: Technology, Goals and Structure', pp910-971 in J G MARCH (ed) 'Handbook of Organisations', Chicago; Rand McNally 1965
- PERROW C (1967), 'A Framework for the Comparative Analysis of Organisations', American Sociological Review, vol 32(2), 194-208
- PERROW C (1970), 'Departmental Power and Perspective in Industrial Firms', in M N ZALD (ed), 'Power in Organisations', Nashville, Tenn; Vanderbilt UP
- PERROW C (1979), 'Complex Organisations: A Critical Essay', (2nd ed) Glenview, Ill; Scott, Foresman & Co
- PETTIGREW A (1972), 'Information Control as a Power Resource', Sociology, vol 6(2), 187-204
- PETTIGREW A M (1979), 'On Studying Organisational Cultures', Administrative Science Quarterly, vol 24(4), 570-581
- PFEFFER J (1972), 'Merger as a Response to Organisational Interdependence', Administrative Science Quarterly, vol 17(3), 328-394
- PFEFFER J (1981), 'Power in Organisations', Marshfield, Mass; Pitman
- PFEFFER J and LEBLEBICI H (1973), 'The Effect of Competition on Some Dimensions of Organisational Structure', Social Forces, 52(2), 268-279
- PFEFFER J and NOWAK P (1976), 'Joint Ventures and Interorganisational Dependence', Administrative Science Quarterly, vol 21(3), 398-418
- PFEFFER J and SALANCIK G R (1974), 'Organisational Decision-Making as a Political Process: The Case of a University Budget', Administrative Science Quarterly, vol 19(2), 135-151
- PHELPS-BROWN E H (1968), 'Report of the Committee of Inquiry into Certain Matters Concerning Labour in Building and Civil Engineering', London; HMSO
- PONDY L R (1967), 'Organisational Conflict: Concepts and Models', Administrative Science Quarterly, vol 12(1), 296-320
- PORTER R (1980), 'Building Contract Conditions', London; Godwin
- PROJECT MANAGEMENT INSTITUTE (1977), 'Realities in Project Management', Proceedings, PMI International Seminar/Symposium, Oct 22-26 1977, Chicago, Ill

- PUGH D S (1973), 'The Measurement of Organisation Structures: Does Context Determine Form?' pp67-86 in D S PUGH (ed), 'Organisation Theory: Selected Readings', Middx; Penguin 1984
- PUGH D S, HICKSON D J and HININGS C R (1969), 'An Empirical Taxonomy of Work Organisations', 'Administrative Science Quarterly', vol 14(1), 115-126
- PUGH D, HICKSON D J, HININGS C R and TURNER C (1968), 'Dimensions of Organisation Structure', 'Administrative Science Quarterly', vol 13(1), 65-105
- RAELIN J A (1980), 'A Madated Basis of Interorganisational Relations: the Legal-Political Network', 'Human Relations', vol 33(1), 57-68
- REVE T and STERN L W (1979), 'Interorganisational Relations in Marketing Channels', 'Academy of Management Review', vol 4(3), 405-416
- ROWBOTTOM R (1977), 'Social Analysis', London; Heinemann
- ROYAL INSTITUTE OF CHARTERED SURVEYORS (1974), 'A Study of Quantity Surveying Practice', London; RICS
- RUBIN J Z and BROWN B R (1975), 'The Social Psychology of Bargaining and Negotiation', New York; Academic Press
- SAMUELSON N M and BORCHERDING J D (1980), 'Motivating Foremen on Large Construction Projects', 'ASCE Journal of the Construction Divison', vol 106(1), 29-36
- SAYLES L R (1976), 'Matrix Management: Structure with a Future', 'Organisational Dynamics', vol 5(2), 2-17
- SAYLES L R (1979), 'Leadership: What Effective Managers Do and How They Do It', New York; McGraw-Hill
- SAYLES L R and CHANDLER M R (1971), 'Managing Large Systems', New York; Harper and Row
- SCHEIN E (1970), 'The Reluctant Professor: Implications for University Management', 'Sloan Management Review', vol 12(3), 35-50
- SCHLACHER H R (1979), 'The Role and Impact of Communication in the Construction Process', in INTERNET CONGRESS (6) Proceedings, vol 4, 117-130
- SCHMIDT S M and KOCHAN T A (1972), 'Conflict: Toward Conceptual Clarity', 'Administrative Science Quarterly', 17(3), 371-381

- SCHMIDT S M and KOCHAN T A (1977), 'Interorganisational Relationships: Patterns and Motivations', Administrative Science Quarterly, vol 22(2), 220-234
- SCHREISHEIM C A and KERR S (1977), 'Theories and Measures of Leadership: A Critical Appraisal of Current and Future Directions' in J G HUNT and L L LARSON (eds) 'Leadership: The Cutting Edge', Carbondale, Ill; S Illinois UP
- SCOTT W E and CUMMINGS L L eds (1973), 'Readings in Organisational Behaviour and Human Performance', Homewood, Illinois; Irwin
- SELZNICK P (1949), 'TVA and the Grass Roots', Berkeley; California UP
- SIMON H A (1960), 'The New Science of Management Decision', New York; Harper and Row
- SIMON H A (1964), 'On the Concept of Organisational Goal', Administrative Science Quarterly, vol 9(1), 1-22
- SIMON H A (1965). 'Administrative Behaviour', London; Heinemann
- SIMON H A and SHAW M E (1964), 'Structured and Unstructured Problems' in BERKOVITZ (ed) 'Advances in Experimental Psychology (vol 1)', New York; Academic Press, 1964
- SLOUGH ESTATES (1979), 'Industrial Investment', Berkshire; Slough Estates Ltd
- SNOWDON M (1979), 'Project Management', Journal of the Institute of Civil Engineers, vol 66(1), 625-633
- SOZEN Z (1981), 'Operationalisation and Measurement of three Strategic Variables in the Study of Building Organisations: Structure, Technology and Size', pp D.2.17-26, in CIOB Proceedings, W65(3), Dublin
- SPENCER L and DALE A (1979), 'Integration and Regulation in Organisations: A Contextual Approach', Sociological Review, vol 27(4), 679-702
- STEINER G and RYAN W (1968), 'Industrial Project Management', New York; MacMillan
- STEWART R (1967), 'Managers and Their Jobs', London; MacMillan
- STEWART R (1976), 'Contrasts in Management', Maidenhead, UK; McGraw-Hill
- STINCHCOMBE A L (1959), 'Bureaucratic and Craft Administration of Production', Administrative Science Quarterly, vol 4(2), 168-187

- STOGDILL R M (1948), 'Personal Factors Associated with Leadership: A Survey of the Literature', Journal of Psychology, vol 25, 35-71
- STOGDILL R M (1974), 'Handbook of Leadership', New York; Free Press
- STRUBE M J and GARCIA J E (1981), 'A Meta-analytic Investigation of Fiedler's Contingency Model of Leadership Effectiveness', Psychological Bulletin, vol 90(2), 307-21
- THAMHAIN H J (1977), 'Leadership, Conflict and Project Management Effectiveness', Sloan Management Review, vol 19(1), 69-89
- THAMHAIN H J and WILEMON D L (1975), 'Conflict Management in Project Life-Cycles', Sloan Management Review, vol 16(3), 31-50
- THIBAUT J W and KELLEY H (1959), 'Social Psychology of Groups', New York; Wiley
- THOMAS A E (1975), 'Management Contracting', in P A HARLOW (ed) 'The Practice of Site Management', (vol 1, 2nd ed), Ascot; Institute of Building
- THOMPSON J D (1967), 'Organisations in Action', Chicago; McGraw-Hill
- THOMPSON P (1981), 'Organisation and Economics of Construction', London; McGraw-Hill
- TRIST E L and BAMFORTH K W (1951), 'Some Social and Psychological Consequences of the Longwall Method of Goal-Getting', Human Relations, vol 4(1), 3-38
- TUITE M, CHISHOLM R and RADNOR M eds (1972), 'Interorganisational Decision-Making', Chicago; Aldine
- TURK H (1970), 'Interorganisational Networks in Urban Society: Initial Perspectives in Comparative Research', American Sociological Review, vol 35(1), 1-18
- TURK H (1973), 'Comparative Urban Structure from an Interorganisational Perspective', Administrative Science Quarterly, vol 18(1), 37-55
- UDY S H (1965), 'The Comparative Analysis of Organisations', in J G MARCH (ed) 'Handbook of Organisations', Chicago; Rand McNally, 1965
- VAN DE VEN A H and DELBECQ A (1974), 'A Task Contingent Model of Work Unit Structure', Administrative Science Quarterly, vol 19(2), 183-197

- VAN DE VEN A H, DELBECQ A and KOENIG R (1976), 'Determinants of Coordination Modes within Organisations', American Sociological Review, vol 41(2), 322-338
- VAN DE VEN A H and FERRY D L (1980), 'Measuring and Assessing Organisation', New York; Wiley
- VAN MAANEN J ed (1979), 'Qualitative Methodology', Beverly Hill, Ca; Sage
- VIDELO D A (1976), 'An Engineering Department Matrix Organisation', R & D Management, vol 6(2), 73-76
- VON NEUMANN J and MORGENSTERN O (1944), 'Theory of Games and Economic Behaviour', Princeton, NJ; Princeton UP
- VROOM V (1964), 'Work and Motivation', New York; Wiley
- VROOM V H and YETTON P W (1973), 'Leadership and Decision-Making', Pittsburgh, Pa; Pittsburgh UP
- WALKER A H and LORSCH J W (1968), 'Organisational Choice: Product vs Function', Harvard Business Review, vol 46(6), 129-139
- WALKER, SMITH and CLOSE (1971), 'Standard Forms of Building Contract', London; Charles Knight
- WALTON R E, DUTTON J M and CAFFERTY T P (1969), 'Organisational Context and Interdepartmental Conflict', Administrative Science Quarterly, vol 14, 522-542
- WARD P A (1979), 'Organisation and Procedures in the Construction Industry', London; MacDonald and Evans
- WARREN R (1967), 'The Interorganisational Field as a Focus for Investigation', Administrative Science Quarterly, vol 12(3), 396-419
- WARREN R L (1972), 'The Concerting of Decisions as a Variable in Organisational Interaction', pp20-32 in TUIITE et al (eds) 'Interorganisational Decision-Making', Chicago; Aldine, 1972
- WEARNE S (1970), 'Project and Product Responsibilities in Industry', Management Decision, vol 4(4), 32-36
- WEARNE S H (1973), 'Principles of Engineering Organisation', London; Arnold
- WEBER M (1947), 'The Theory of Social and Economic Organisation', New York; Free Press

- WEICK K (1976), 'Educational Organisations as Loosely-Coupled Systems', Administrative Science Quarterly, vol 21(1), 1-19
- WEINER H (1970), 'Role Perception and Organisation Ineffectiveness in the Foreign Service', Cambridge, Mass; MIT Press
- WILEMON D L (1972), 'Project Management and its Conflicts: A View from Apollo', Chem Tech, 1972, 527-534
- WILEMON D A and CICERO J P (1970), 'Project Management: Anomalies and Ambiguities', Academy of Management Journal, vol 13(3), 269-282
- WILEMON D L and GEMMILL G R (1971), 'Interpersonal Power in Temporary Management Systems', Journal of Management Studies, vol 8(4), 315-328
- WILLIAMS E C (1978), 'Matrix Management offers Advantages for Professional Services Firms', Professional Engineer, vol 48(2), 14-18
- WILLIAMSON O E (1975), 'Markets and Hierarchies: Analysis and Antitrust Implications', New York; Free Press
- WILSON (1974), 'Before You Build - What a Client Needs to Know About the Construction Industry', (NEDO) London; HMSO
- WOOD (1975), 'The Public Client and the Construction Industries', (NEDO) London; HMSO
- WOODWARD J (1958), 'Management and Technology', London; HMSO
- WOODWARD J (1965), 'Industrial Organisation: Theory and Practice', Oxford; Oxford UP
- YANOZAS J N (1964), 'A Comparative Study of Work Organisation and Supervisory Behaviour', Human Organisation, vol 23, 245-253
- YIN R K (1984), 'Case Study Research', Beverly Hill, Ca; Sage
- YUCHTMAN E and SEASHORE S (1967), 'A System Resource Approach to Organisational Effectiveness', American Sociological Review, vol 32(6), 891-903
- YUKL G (1971), 'Toward a Behavioural Theory of Leadership', Organisational Behaviour and Human Performance, vol 6, 414-440
- ZILLER R C, STARK B J and PRUDEN H O (1969), 'Marginality and Integrative Management Positions', Academy of Management Journal, Dec 1969, 487-495

