

THE USE OF MICRODIALYSIS AND METABOLOMICS TO STUDY
THE BIOMARKER DIFFERENCES BETWEEN DONATION AFTER
CIRCULATORY DEATH (DCD) AND DONATION AFTER BRAIN
DEATH (DBD) LIVER GRAFTS IN ORTHOTOPIC LIVER
TRANSPLANTATION

By

THAMARA PRABHATH RANASINGHE PERERA

A thesis submitted to the University of Birmingham for the degree of
DOCTOR OF MEDICINE



Centre for Liver Studies
School of Immunity and Infection
College of Medical and Dental Sciences
University of Birmingham
June 2015

UNIVERSITY OF
BIRMINGHAM

University of Birmingham Research Archive

e-theses repository

This unpublished thesis/dissertation is copyright of the author and/or third parties. The intellectual property rights of the author or third parties in respect of this work are as defined by The Copyright Designs and Patents Act 1988 or as modified by any successor legislation.

Any use made of information contained in this thesis/dissertation must be in accordance with that legislation and must be properly acknowledged. Further distribution or reproduction in any format is prohibited without the permission of the copyright holder.

ABSTRACT

Donor organ shortage is a major barrier to the progress of liver transplantation; options to widen the donor pool include use of marginal donor grafts and those from donors after circulatory death (DCD), despite risks of early graft failure. This thesis studies the key metabolic feature differences between DCD and from donors after brain death (DBD), using combination of microdialysis for tissue fluid sampling, and colourimetry, Coularray and Fourier transform ion cyclotron resistance - mass spectrometry (FTICR-MS) as analytical platforms. The initial study proved feasibility of above methods to identify metabolic changes through cold storage to reperfusion, and the involvement of energy and amino acid metabolism pathways. Comparison of DCD and DBD grafts by microdialysis combined with colourimetry proved energy depletion, and increased lactate/pyruvate ratio in DCD grafts. Metabolomic studies consolidated the findings of primary impact on energy metabolism pathways during cold storage. Both CEAD and FTICR-MS identified key biomarker differences and the effect on tryptophan and kynurenine pathway, and this finding was reproduced in all three metabolomic studies conducted. Over expression of these metabolites in DCD grafts and failed allografts may be related to energy metabolism, and tryptophan and kynurenine could potentially be developed as biomarkers predicting liver graft function.

In loving memory of my Mom and Dad

ACKNOWLEDGEMENTS

Work leading to this thesis created several hurdles; a lot of my time was devoted to the clinical activities in a busy liver transplant unit and this drove my research ideas. Many people have supported me in my academic and clinical career and I am grateful for all of them for showing me the path; few stand out! Professor Kemal Deen, Chair of Surgery at the Medical School of University Kelaniya, Sri Lanka where I had my undergraduate education was my first role model. Also alumni of University of Birmingham, he is partly responsible for ethos I follow to date. I am forever grateful for his teachings and guidance and encouragement to undertake research work. Professor Darius Mirza at the Liver unit in Birmingham was my teacher, mentor and my second role model who then became a personal friend with whom I often share my thoughts. Without his tremendous support I would be without this academic work or the liver transplant skills. Together, above two greats influenced my professional career. The third person I am going to acknowledge is also a fellow countryman who was at the Liver unit in Birmingham during the days I was hunting for a transplant fellowship. Mr. Michael Silva not only provided me with the opportunity to join the team in Birmingham, but also set up the preliminary work and background related to the research presented in this thesis, continuing from his initial work in microdialysis in liver transplantation. I did not foresee at the beginning of my career in surgery twelve years ago, any of the opportunities that have come my way since; “You can’t connect the dots looking forward; you can only connect them looking backwards.....” – *Steve Jobs, Stanford commencement address, 2005*

I am grateful to all my patients willingly consented to interventions and to take part in the studies outlined in this thesis. Next, I am thankful to all members and collaborators of our research group; Doug Richards has been exceptionally supportive of my projects through the years, and Nick Murphy, Mark Viant, Olga Hrydziusko, Jennifer Kirvan, Desley Neil all helped me immensely in completing

this work. I am also thankful to the external collaborators; Roger Higdon and Eugene Kolker from the Bioinformatics and High-throughput Analysis Lab, Centre for Developmental Therapeutics at Seattle Children's Research Institute, who collaborated with me during the data analysis phase. Jean Shaw, Bridget Gunson and Sue Paris were tolerated my numerous requests of consumables, reagents or data and I am grateful to them. Former consultants at the liver unit Professor John Buckels and Mr. David Mayer, along with Mr. Simon Bramhall, Mr. John Isaac and Mr. Paolo Muiesan, some of them later became my colleagues, were very patient during my days as a research fellow, and allowed me to insert tiny little catheters in to the liver grafts used by them. The liver theatres, intensive care unit members and the ward staff never complained I appreciate their invaluable support throughout. Also I am thankful to those helped me carry forward the research work based on what we have uncovered through the studies outlined here, namely Hermien Hartog, Gary Reynolds, Stefan Hubscher and Jeremy Tomlinson.

All this work was possible because I also had the wonderful support from my family. The sacrifices made by Nierosha, my soul partner in life, were enormous as she shouldered all the responsibilities of raising our two little angels while I was engrossed in work. I must also confess that she constantly reminded me of completing this thesis, but not always in the appropriate times! I am grateful that those reminders set targets for me - now that I have completed the thesis I will be expecting reminders on other things I have conveniently forgotten in life.

Table of Contents

CHAPTER 1	INTRODUCTION	1
1.1	Liver Transplantation	1
1.2	Current issues	5
1.3	Donor organ shortage	6
1.4	The marginal donor	7
1.5	Graft steatosis.....	10
1.6	Donation after circulatory death	12
1.6.1	Donor warm ischaemia	14
1.7	Graft preservation	16
1.7.1	Cold ischaemia	16
1.7.2	Preservation-reperfusion injury.....	18
1.8	Primary non-function.....	19
1.9	Biomarkers predicting graft function	20
CHAPTER 2	RESEARCH HYPOTHESIS AND STUDY PLAN	22
2.1	Research aim	22
2.2	Research proposal	24
2.3	Study design.....	26
2.3.1	The donor operation	26
2.3.2	Liver transplantation technique	28

2.4	Microdialysis.....	30
2.4.1	Microdialysis in liver transplantation	31
2.4.2	Microdialysis catheter	32
2.4.3	Microdialysis Fluid.....	34
2.4.4	Microdialysis pump	35
2.5	Technique of Microdialysis	35
2.5.1	Microdialysis kit.....	35
2.5.2	Procedure	35
2.6	Sampling protocols	37
2.7	Metabolomics	40
CHAPTER 3 PROOF OF PRINCIPLE: METABOLOMICS IN HUMAN LIVER TRANSPLANTATION		43
3.1	Liver biopsy and FT-ICR MS metabolomics.....	44
3.2	Extracellular fluid and CEAD metabolomics	45
3.3	Histology	47
3.4	Results.....	48
3.4.1	Liver metabolism of cold phase vs. post reperfusion	48
3.4.2	Redox metabolism in microdialysates post reperfusion.....	55
3.5	Discussion.....	56
CHAPTER 4 CHANGES IN BASIC ENERGY METABOLISM AND KEY DIFFERENCES IN LIVER GRFATS FROM DCD AND DBD DONORS		60
4.1	Introduction	60
4.2	Methods	64

4.2.1	Microdialysis analyser and colourimetry.....	64
4.2.2	Statistical analysis	69
4.3	Patient and graft characteristics.....	69
4.4	Results.....	71
4.4.1	Interstitial lactate and pyruvate level.....	71
4.4.2	Glycerol levels	75
4.4.3	Graft outcomes.....	75
4.5	Discussion.....	76
CHAPTER 5 KEY METABOLITE FEATURE DIFFERENCES BETWEEN DCD AND DBD LIVER GRFATS IDENTIFIED THROUGH CEAD BASED METABOLOMICS		80
5.1	Introduction	80
5.2	Coulometric electrochemical array detection (CEAD)	81
5.2.1	CEAD sample and data analysis:	83
5.3	Patients and methods.....	84
5.4	Results.....	86
5.4.1	Overall metabolic activity detected by CEAD	86
5.4.2	Bench Samples – Donor Type and Cold Ischemia	86
5.4.3	First Reperfusion Sample – Donor Type, Cold and implantation time ..	90
5.4.4	Mean of Post Reperfusion Samples – Donor Type, Cold and implantation time.....	92
5.4.5	Differences in Patients with Poor Graft Function patients for Bench, First Reperfusion and Mean Reperfusion Samples	96
5.5	Summary of main metabolite differences	97

5.6	Discussion.....	99
CHAPTER 6 FTICR BASED MASS SPECTROMETRY ANALYSIS OF DCD AND DBD LIVER GRAFTS USED IN CLINICAL LIVER TRANSPLANTATION		
105		
6.1	Introduction	105
6.2	Fourier Transform Ion Cyclotron Resistance – Direct Infusion (FTICR-DI) mass spectrometry	107
6.2.1	Basis of FTICR	107
6.2.2	Mass spectrometer	110
6.2.3	FTICR data analysis.....	112
6.2.4	FTICR data: Statistical analysis	114
6.2.5	Putative assignment of metabolites	115
6.3	Patients and graft characteristics.....	116
6.4	Changes in hepatic metabolism during transplantation	118
6.5	Hepatic metabolism in DBD compared to DCD grafts	122
6.6	Discussion.....	127
CHAPTER 7 CONCLUDING REMARKS AND FUTURE WORK.....		
129		
7.1	Graft function and energy metabolism.....	129
7.1.1	Re-charging the energy status of liver grafts as an option for successful liver transplantation	131
7.1.2	Insulin, insulin like growth factor-I (IGF-I) and liver	132
7.1.3	Insulin resistance and liver transplantation.....	136
7.1.4	Energy metabolism and Insulin resistance could be the cause of graft failure in steatotic grafts.....	137

7.2	Biomarkers of poor graft function	138
7.3	Summary of future directions.....	140
CHAPTER 8 END PAGES		141
8.1	APPENDICES.....	141
8.1.1	Appendix 1	142
8.1.2	Appendix 2	143
8.1.3	Appendix 3	144
8.1.4	Appendix 4	145
8.2	BIBLIOGRAPHY.....	146

List of Illustrations

- Figure 1-1: Global liver transplant activity (source - Global observatory on Donation and Transplantation); in most of the countries where there is busy transplant activity the organ donor sources are cadaveric than live donation4
- Figure 1-2: Trends of organ donation in the United Kingdom; the average donor age is increased over past ten years and majority of the organ donor pool is over 50years of age.....9
- Figure 1-3: Changing demographics of organ donation in the United Kingdom; there is progressive increase of organ donors with BMI over 30 denoting significant proportion of donors are likely to be marginal..... 10
- Figure 2-1: The processes involved in the liver transplantation from the donor to the recipient; graft ischaemia is inevitable outcome leading poor or good graft function providing space for the investigation of metabolic differences between these two outcomes 25
- Figure 2-2: The microdialysis catheter with its components..... 33
- Figure 2-3: the components of a microdialysis catheter (reproduced from CMA microdialysis)..... 33
- Figure 2-4: Schematic representation of the sampling end of the microdialysis catheter; the perfusate enter the sampling end through the inner core which equilibrates with the solutes within the interstitial space as it runs through the outer tube (Perera BJS 2014) 34
- Figure 2-5: Insertion of microdialysis catheter in to the liver graft during bench phase sampling; the catheter is held in place with a pair of forceps while the splittable introducer (light blue handles) is gently withdrawn 36
- Figure 2-6: Microdialysis catheter in-situ in a transplant recipient; the catheter has been introduced at the level of falciform ligament directed towards the segment IV of the liver graft; a superficial suture used to secure the microdialysis catheter to the falciform ligament 37
- Figure 2-7: The Menghini biopsy needle used for allograft biopsy sampling during the cold storage and post reperfusion; needle supplied with blocking pin that prevent suction of biopsy material to the syringe, trocar and obturator (from Dixon surgical Instruments, UK)..... 38
- Figure 2-8: study of metabolomics and different approaches; the diagram illustrates that that the entire metabolome cannot be studied by one analytical platform alone and combination of techniques may be used to detect metabolites according to the particle size present [adapted from Van der Greef et al. "The role of metabolomics in systems Biology", In: Metabolic Profiling, Kluwer (2003)] 41

Figure 3-1: Principle analysis scores plot for liver biopsy spectra in the positive and negative ion mode; cold phase (green) and post reperfusion (red) showing an expected separation between spectra from liver biopsies in each phase is shown but within each phase close clustering could be seen.....	48
Figure 3-2: Principle score analysis plot for CEAD time course data. First time point for each patient is on the right as also indicated by the patient labels and time trajectory for the samples from each patient follows a similar trend.....	55
Figure 3-3: Principle scores plot for CEAD time course data (first time point for each patient is on the right, as also indicated by the patient label) showing that the metabolism following reperfusion changed rapidly to stabilize nearly 21hrs post reperfusion.....	56
Figure 4-1: Mean (standard error of mean) of lactate, pyruvate and calculated lactate: pyruvate ratio; showing initial high levels. Lactate/pyruvate ratio was initially high in the immediate post reperfusion period and then dropped to baseline levels.....	63
Figure 4-2: The ISCUS microdialysis analyser (reproduced from product note ISCUSfelx.pdf http://www.mdialysis.com/analyzers/iscusflex-for-point-of-care)....	64
Figure 4-3: chemical reactions leading to the colorimetric detection of lactate present within sample by the microdialysate analyser.....	66
Figure 4-4: Chemical reactions leading to the detection of pyruvate concentration of a sample by the microdialysate analyser	67
Figure 4-5: Chemical reactions leading to the detection of glycerol concentration of sample by the microdialysate analyser	68
Figure 4-6: Median lactate levels in microdialysate samples obtained from cold phase sampling through to 48hours post reperfusion; comparison between graft types ($p < 0.05$).....	72
Figure 4-7: Median pyruvate levels in microdialysate samples from cold storage sampling through to 48hours post reperfusion; comparison between graft types showing that both DCD and DBD grafts had lower levels pyruvate ($p = n.s$) at the end of the cold storage and these were progressively replenished upon reperfusion.	73
Figure 4-8: Comparison between calculated lactate/pyruvate ratio between DCD and DBD grafts during the cold phase sampling; DCD grafts had greater energy depletion represented by higher lactate/pyruvate ratio in the cold phase ($p < 0.05$)	74
Figure 4-9: comparison of lactate/pyruvate (median) trends between the DCD and DBD grafts from cold storage through to 48hours post reperfusion; the higher lactate pyruvate ration present in the DCD grafts in the cold phase rapidly reversed and comparable ratios are seen upon reperfusion	74
Figure 4-10: Comparison of median glycerol levels between DCD and DBD grafts from cold storage through to 48hours post reperfusion; DCD grafts had non-significantly elevated interstitial glycerol levels.....	75

Figure 4-11: Comparison of median lactate/pyruvate levels of failed allografts due to poor function against those with successful outcomes; the bottom straight line represents the median values for lactate/pyruvate in all successful grafts, and the failed allografts showed greater lactate/pyruvate ratios compared with successful grafts	76
Figure 5-1: The curve displays the percentage of mobile phase B in the eluent over the 45 minute time period for each sample injection, the remainder being mobile phase A (Perera et al. 2014a)	82
Figure 5-2: Heat map of normalised metabolite expression values; columns represent patient samples (Red - DBD, Blue - DCD) and rows represent the metabolite peaks labeled by their retention time. Samples and peaks are clustered by expression patterns (Perera et al. 2014a)	88
Figure 5-3: Overall trend of selected metabolites with cold ischaemia time elapsed against metabolite intensity for the cold storage samples	89
Figure 5-4: Trend of cold ischaemia time with metabolic intensity (selected metabolites) for the first reperfusion samples (Blue corresponds DBD donors, Orange DCD donors) through CEAD analysis of microdialysate samples.	91
Figure 5-5: Trends of implantation time with metabolic intensity observed in the first reperfusion samples (Blue corresponds to DBD donors, Orange DCD donors)	92
Figure 5-6: Trend of cold ischemia time with metabolite intensity for the mean of reperfusion samples. Blue corresponds to DBD donors and orange DCD donors.	94
Figure 5-7: Trend of warm ischemia time with metabolite intensity for the mean of post reperfusion samples. Blue corresponds to DBD donors and orange DCD donors.	95
6-1: The schematic representation of basis of FTICT mass spectrometry (source: Department of Biosciences, University of Birmingham)	109
6-2: Typical example of a FTICR mass spectrometry pattern showing different metabolite peaks according to the respective m/z ratio	110
6-3: The Thermo LTQ FT Ultra mass spectrometer with key elements labeled (Image courtesy – Jennifer Kirwan, Department of Biosciences, University of Birmingham)	111
Figure 6-4: Example chromatogram from FTICR-MS assay of a sample used in the study; the relative abundance is of a metabolite identified by m/z ratio is represented in the Y-axis	114
Figure 6-5: Principle component analysis scores plot showing the similarities and differences between the metabolic profiles of the grafts in donor (T_0), cold (CP, T_1) and post-reperfusion phases (PR, T_2). Donor and post-reperused biopsies cluster together and have distinctive metabolic profiles compared to the cold-phase biopsies, indicative of the	

rapid resumption of the biochemical functions in the post-reperfused grafts in the direction of the ‘healthy’ donor grafts. 120

Figure 6-6: Principle component analysis scores plots highlighting the metabolic separation of the DBD and DCD grafts in the cold phase (CP) and separately the post-reperfusion phase (PR), based on analyses of just the 50 and 64 peaks identified as being significantly different (between DBD and DCD) for the CP and PR groups, respectively. 123

Figure 6-7: The differences between tryptophan and kynurenine in failed allografts due to primary non-function (n=2) vs. other allografts (n=36) in the cold phase (grey) and post reperfusion (blue). The data show the relative abundances of the metabolites with 95% confidence intervals (statistics not applied due to limited sample size) 126

7-1: the mechanisms of actions of hormones insulin, insulin like growth factor-I (IGF-I) and IGF binding protein (IGFBP)..... 134

List of Tables

Table 3-1: Demographics, timings of liver allograft biopsy, total cold ischaemia times and period of reperfusion established prior to the T2 biopsy, combined with intra-operative parameters and outcomes of the graft recipients in the study.....	46
Table 3-2: Histological grading of graft steatosis (microvesicular and macrovesicular) of the grafts used in the proof-of-principle study. Macro and micro-vesicular steatosis is expressed as a percentage during cold phase and post reperfusion biopsy samples and an increase in microvesicular steatosis is noted in post reperfusion samples whereas macro-vesicular steatosis remains somewhat unchanged	47
Table 3-3: Putatively identified metabolites for peaks within 1% top PC1 loadings in FTICR analysis, smallest p values largest (up and down) fold changes	50
Table 3-4: Peaks identified in the KNN algorithm (successful vs. unsuccessful grafts) with putative metabolite assignments and corresponding KEGG pathways; fold change calculated as mean of successful peak divided by mean of unsuccessful field level	52
Table 4-1: Demographics of liver transplant recipients, donors and liver allografts between DCD and DBD groups in the study group; both groups are comparable for donor, graft and operative characteristics apart from the dWIT.....	70
Table 5-1: The recipient demographics, donor demographics and graft characteristics including steatosis, ischaemia times and degree of ischaemia reperfusion of assessed by histological grading following reperfusion.....	87
Table 5-2: Significant metabolite differences (metabolite denoted by corresponding retention time) between DCD and DBD grafts during cold storage sampling	89
Table 5-3: Main differences observed in 1st reperfusion microdialysis sample; metabolites identified by retention time peak.....	90
Table 5-4: Key metabolite differences for Mean of post reperfusion samples (6-48hours) through CEAD analysys; metablites identified by retention time	93
Table 5-5: Overall metabolite peak differences of failed allografts and expression ratio of such peaks. The peak at 10.23minutes has the highest expression ratio and identified as kynurenine	96
Table 5-6: Summary of key metabolites and differences observed in during each phase post reperfusion with relevance to the different graft types.....	98
Table 6-1: The characteristics and basic demographics of the recipients undergoing liver transplantation.....	117
Table 6-2: Top putatively annotated metabolic fold-changes (FC) in the liver grafts between donor phase (D, T ₀), cold phase (CP, T ₁) and post-reperfusion phase (PR, T ₂), considering the DBD and DCD biopsies as one group.	121

Table 6-3: Top putatively annotated metabolic fold-changes between the DCD and DBD grafts: combined results for the comparison, (i) in the cold phase (CP, T₁), (ii) following reperfusion (PR, T₂), and (iii) in response from going from CP (T₁) to PR (T₂) 122

Table 6-4: Metabolic pathways discovered to differ significantly between DCD and DBD grafts, including the associated putatively annotated metabolites in those pathways. 125

ABBREVIATIONS

3-NT	3-Nitrotyrosine
ALD	alcoholic liver disease
AMP	adenosine monophosphate
ANOVA	analysis of variance
AST	aspartate transaminase
ATP	adenosine triphosphate
BMI	body mass index
CEAD	coulometric electrode array detection
CIT	cold ischaemia time
CP	cold phase
DBD	donation after brain death
DCD	donation after circulatory death
DCHBS	5-dichloro-2-hydroxy-benzene sulphonic acid
DIMS	direct injection mass spectrometry
dWIT	donor warm ischaemia time
ESLD	end stage liver disease
FTICR	Fourier transform ion cyclotron resonance
GC	gas chromatography
GH	growth hormone
GMP	Guanosine monophosphate
HBV	hepatitis B virus
HCV	hepatitis C virus
HMMA	4-Hydroxy-3-methoxymandelic acid
HoS	Hyper-osmolar solution
HPLC	High Performance Liquid Chromatography
IDO	indoleamine 2-3 dioxygenase
IGF-1	insulin like growth factor-I
IGF-1R	insulin like growth factor-I receptor

IGFBP	insulin like growth factor binding protein
IGL-1	Institut Georges Lopez-1
IPF	initial poor function
IR	insulin receptor
ITBL	ischaemic type biliary lesions
L/P ratio	lactate:pyruvate ratio
LC	liquid chromatography
LDLT	live donor liver transplant
MELD	model for end stage liver disease
MS	mass spectrometry
NASH	non-alcoholic steatohepatitis
NHSBT	National health service blood and transplant
NMR	nuclear magnetic resonance
NODAT	new onset diabetes after transplantation
NTI	non-thrombotic infarction
OLT	orthotopic liver transplantation
PBC	primary biliary cirrhosis
PCA	principle component analysis
PCLD	polycystic liver disease
PNF	primary non-function
POD	Peroxidase
PR	Post-reperfusion
PRI	post reperfusion injury
PSC	primary sclerosing cholangitis
ROS	reactive oxygen species
SAM	S-adenosyl methionine
SIM	selected ion stitching
TDO	tryptophan 2-3 dioxygenase
TM	transformation mapping
UW	University of Wisconsin

CHAPTER 1 INTRODUCTION

1.1 Liver Transplantation

The history of liver transplantation in humans goes back over half a Century and no other surgical procedure has undergone transformation from its original description to what it is today (Starzl et al. 1963). Other than the technical successes of this operation, the complexity of patients, the overall post operative care including immunosuppressant management (Iwatsuki et al. 1988; Todo et al. 1990) and prevention of both immune and infective complications that were primary barriers have dramatically changed in the past 50 years (Calne et al. 1979). When the first attempt of liver transplantation was made 1963 albeit unsuccessfully, the graft taken from a cadaveric donor confirmed after circulatory death and the transplant operation did not see the anticipated success (Starzl, Von Kaulla, Hermann, Brittain, & Waddell 1963). Two years on from the undesired outcome the first successful transplant operation was carried out however the initial success was limited to only 28% patient survival in the first one year (Starzl et al. 1979). The progress made in the field of liver transplantation in the last five decades is probably incomparable to other branches in medicine. In the early era, liver transplantation was considered a huge undertaking with significant risks of mortality. Bleeding was the primary concern in those candidates undergoing transplantation, primarily related to the poor coagulation status resulting from the chronic liver damage and portal hypertension (Bontempo et al. 1985). In addition alternative techniques developed for explanation of the damaged liver, for example by-passing both portal and systemic circulation (Shaw Jr et al. 1984), in addition to the technological innovations that also have contributed to the success (Starzl et al. 1985).

Liver transplantation was initially introduced as the treatment of choice for end stage liver disease (ESLD). With the successful results and acknowledgement of these by the medical community not only caused a surge in patients with ESLD referred for transplantation, but also widened the indications for liver transplantation

(Neuberger 2004). Chronic hepatitis virus infection (Hepatitis B and C) is a global health problem and majority of these patients ended up with ESLD or primary liver cancer (hepatocellular carcinoma) on the background of cirrhosis (Bismuth et al. 1987). Currently, a significant proportion of patients undergoing liver transplantation are comprised of primary liver tumours (Iwatsuki et al. 1985; Mazzaferro et al. 2008). Diagnostic accuracy in detection of early primary liver cancer, newer contrast agents have contributed to huge expansion of cancer patient group (Colli et al. 2006). Alcohol is a universal problem and up to one fifth of liver transplant recipients had alcohol related aetiology for treatment (Neuberger 1989). In addition to those with chronic ESLD, acute hepatic insufficiency or failure was also considered an excellent indication for transplantation. In a majority of patients with acute liver failure, the physiological and biochemical sequelae could be only reversed by liver replacement as the chances of hepatic regeneration is remote in most of these cases (O'Grady et al. 1991). More indications for liver transplantation included metabolic disorders, where the actions of some of the enzyme defects or metabolic pathways have actions on other end organs resulting in disability or disease status. In this group of patients, the structural and normal hepatic synthetic capacity is essentially normal apart from the presence of defective metabolic pathways due to genetic mutations. Urea cycle defects (Saudubray et al. 1999), familial amyloidosis (Holmgren et al. 1993) and primary hyper-oxaluria are classic examples for these metabolic disorders (Watts et al. 1991). All of these new additions to the liver transplant indications have caused the transplant wait listed patients to grow.

Apart from the survival advantages resulting from liver transplantation, improvement in quality of life following a successful operation is remarkably different to other forms solid organs transplant. Physical status, sexual health and social functioning are remarkably better after liver transplantation (Bravata et al. 1999). Some of these results are attributed to the metabolic and biological changes brought about by the graft, nevertheless the reduced allogenicity and immune-protective capabilities of the liver is primarily responsible for reduced incidence of acute cell mediated or antibody mediated immune responses. As a result the majority of patients could be managed with lower levels of maintenance immunosuppression

without the need for more frequent or intense monitoring. Of course the advent of newer immunosuppressive medication, in particular calcineurin inhibitors and tacrolimus further improved the long term outcomes of liver transplantation and the short term survival figures improved from 60-70% at 85-90% following these developments (Wiesner 1998).

Currently liver transplantation accounts for the second most frequent organ transplanted in solid organ transplantation programs worldwide, and second only to renal transplantation. In the year 2012 alone, nearly 24 000 liver transplants were performed in 68 countries across the world according the data from the Global Observatory of Organ Transplantation (www.transplant-observatory.org). In the United Kingdom there has been a steady increase the transplant activity in the recent past and nearly 800 liver transplants were performed in the year 2012/2013. And according to the National Health Service Blood and Transplant (NHSBT), the regulatory body in the United Kingdom for organ transplantation, the increase in the liver transplant activity is on the rise over the recent years and the projected number of transplants by 2020 is expected to be around 1000.

Most of the transplant programs are reliant on cadaveric donors for the supply of organs. In these countries the concept of brain death or brain stem death is widely accepted and legalised to ensure the organ donation process is ethically and medically acceptable (Truog and Robinson 2003). Most of the countries in Europe and America have accepted cadaveric organ donation. However, in some other countries there are barriers to cadaveric organ donation and these are primarily due religious, ethical and psychological issues concerning the confirmation of death (Horton and Horton 1990). In those countries therefore the only form of organ donation is live donation. Liver transplantation using a hemiliver or segmental graft from a live donor itself is a technical advancement that was mastered by surgeons in the past two decades, enabled by our current understanding of segmental anatomy, blood supply and drainage of liver (Azoulay et al. 2001;Tanaka et al. 1993). In 13 countries in the world, the live donor liver transplant activity exceeds the cadaveric transplant activity (figure 1-1) and the results of live donor liver transplantation are

comparable, if not superior to transplants carried out with organs from cadaveric donors.

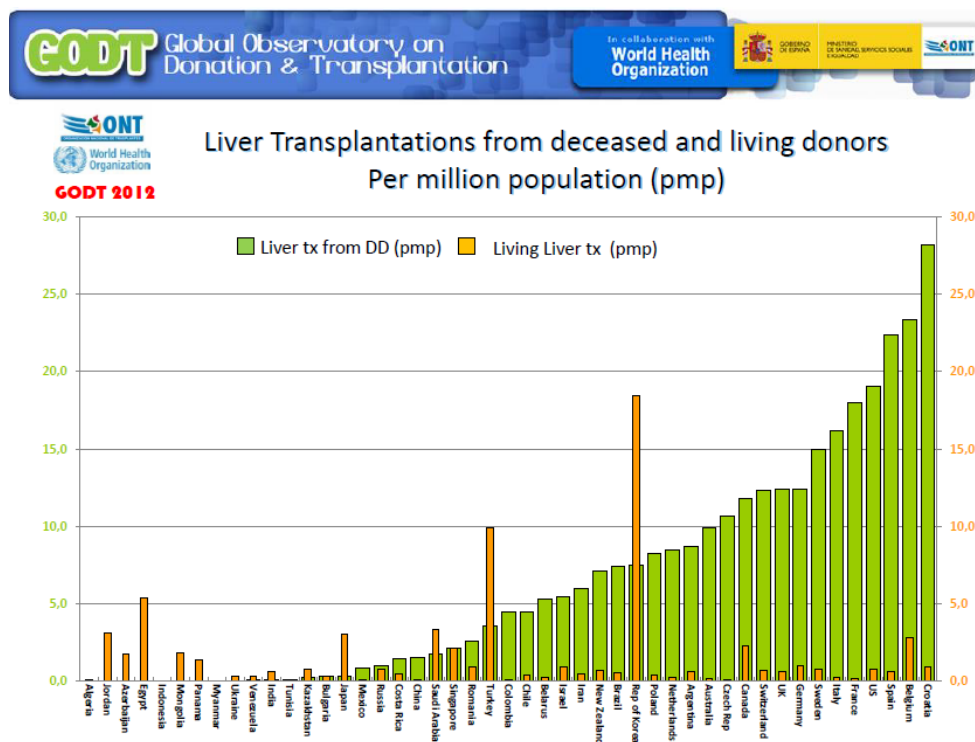

Figure 1-1: Global liver transplant activity (source - Global observatory on Donation and Transplantation); in most of the countries where there is busy transplant activity the organ donor sources are cadaveric than live donation

1.2 Current issues

Increased number of patients added to the liver transplant wait list is a global trend (Kim et al. 2006). This growing demand for organs is a problem not limited to the prospective liver transplant candidates alone, but affects all other solid organ transplant recipients on the wait lists. The increase in demand for the organs is due to many reasons, and foremost is the reliability of solid organ transplantation as the best modality of treatment over other conservative and less invasive procedures. Transplantation makes a patient less dependent on organ support measures which require repeated hospital admission, incurring significant loss in the quality of life and also associated with huge financial burden to the patients as well as healthcare institutions, whereas organ transplantation makes less dependency on the health care resources during the follow up and more independence with return to normal social life.

The current organ supply however does not meet the demand, leaving a widening gap between the organ supply and the demand. It is estimated that current transplant activity caters only about 10% of those in need of a solid organ transplant according to world wide data. With regards to liver transplantation, this gap cannot be filled by cadaveric donor sources alone, therefore the transplant centers pioneered cadaveric transplant activity also have taken up liver donation as a supplemental organ source to meet the demand. In the Europe and America there has been an increase in liver donor transplant activity in the past decade that accounts up to 5.2% and 13.4% of total liver transplants respectively. This is in contrast to the 83.5% of peak liver transplant activity reported in the Middle East and Asia.

In addition to live liver donation as a solution to organ shortage, many other strategies have been introduced primarily through surgical innovation and understanding disease aetiologies. These include split liver transplantation, the cadaveric counterpart of liver donation. The advantage of split liver transplantation is such that it yields two unequal grafts which could especially benefit those recipients disadvantaged in organ allocation systems due to the smaller body size

(Azoulay, Castaing, Adam, Savier, Delvart, Karam, Ming, Dannaoui, Krissat, & Bismuth 2001). Primarily paediatric liver transplant recipients benefit from split liver transplantation, and probably the only source of organs in those programs solely reliant on cadaveric organ donation. Moreover, split liver transplantation has moved one further, and full left-right split may even benefit two adult recipients (Gundlach et al. 2000). Domino liver transplantation is for of organ exchange between patients where a diseased liver explanted from a recipient is (ex. Familial amyloid polyneuropathy) transplanted to another recipient who is in dire need of a graft (Wilczek et al. 2008). There a risk of disease transmission from the domino donor to the domino recipient in this case, however overall benefits of liver transplantation in the domino recipient outweigh the risks of disease transmission.

Although these pioneering surgical techniques have added extra organs to the cadaveric donor pool the gap between the net organ supply and demand has not been reduced. The impact caused by these innovative techniques is probably insignificant when applied to the global situation of organ donation. Therefore the major current issue faced by the global transplant community, donor organ shortage still remains a significant issue without a definitive solution.

1.3 Donor organ shortage

As discussed above the pioneering cases of experimental liver transplantation were performed with donors following cardiac death, but towards the end of the first decade after liver transplantation was introduced, the concept of “brain stem death” determination was universally accepted by many centers in the world (Veith et al. 1977;Youngner et al. 1989). Catastrophic brain injury due to spontaneous or traumatic events caused irreversible brain injury and despite this the organs of the rest of the body functioned for a period of time as long as the vital organs are kept alive by advanced intensive care based medical management through organ support (Frowein et al. 1989). Once the medical support is discontinued these patients progress to natural death, hence the neurological death confirmed by brain stem death criteria was considered a synonym of natural death (Kaste et al. 1979). It was

then accepted that these patients could potentially donate their organs and the organs from these prospective donors remain alive until the time of organ procurement. This was a major shift in organ donation practice that changed the transplantation practice and by the late 20th Century the majority of the organs donors were those following brain stem deaths (DBD).

Perception of LDLT as a suitable organ source for liver graft shortage was accepted at different paces by many, and there were clear geographical variations. Primarily the Far East and Eastern countries where there is legislative, infrastructural or religious barriers to cadaveric donation, LDLT was the only viable organ donor source. In the Western world LDLT was considered a supplementary donor organ source to existing cadaveric transplant programs and the contribution to the overall donor pool is low (Schemmer et al. 2005). Ethical considerations of donor morbidity and mortality were considered major obstacles in the western world for rapid dissemination and wide embrace of LDLT practice. Instead, the majority of these centers relying on cadaveric programs explored the use of more marginal donor organs that were earlier deemed unsuitable for transplantation.

1.4 The marginal donor

The majority of the donors conforming to the criteria of brain stem death determination were initially comprised from victims of catastrophic neurological events (Kompanje et al. 2011). The success in the surgical field of liver transplantation, research in to new drug developments and anti-rejection strategies, better understanding of immunological mechanisms in the transplantation field was perhaps parallel to the other developments of socio-economic aspects of the society, and these include improved road networks, industrialization and expansion of automobile industry that saw the increased road travel (Park 2004). Road accidents were common and young victims of such road accidents were confirmed brain dead and constituted the majority of donors in the late 20th Century (Bendorf et al. 2012).

Being young individuals devoid of other co morbidities, the quality of the liver graft and other solid organs donated by these patients were considered the best in quality and the numbers were sufficient to provide the organs required for transplant programs starting to practice liver transplant procedure. As the transplant wait lists grew and in parallel safety measures were introduced in the automobiles which reduced the number of accident victims. The resulting outcome was a widening disparity between the supply and the demand for organs.

The epidemiology of organ donation has gone through a paradigm change over the last couple of decades (DeCarlis et al. 1996;Summers et al. 2010). The young, healthy and fit donor population has been replaced by more elderly, obese donor population with other co-morbidity (Attia et al. 2008). Increased life expectancy from the advanced medical management is one reason. Changing lifestyle, socio-economic status, cultural and behavioral patterns including substance use is different in the current era. This means the catastrophic neurological events that fulfill the criteria to be tested for brain stem death are either spontaneous brain bleeding or infarctions in group of patients who are also likely to have other co morbidity like hypertension, diabetes, obesity or other metabolic disorders. The organ donation situation has therefore changed from a donor pool consisting a younger donor pool in the late 20th Century to a more elderly donor population in the recent past (Borchert et al. 2005;Cohen et al. 1997). The data from the United Kingdom is a fine example to this phenomenon where the younger donor population was gradually replaced by more elderly donors. Over the past decade the donors under 50 years have reduced from 59% to 42%, an almost 50% drop in the young donors in the United Kingdom in 10 years (figure 1-2).

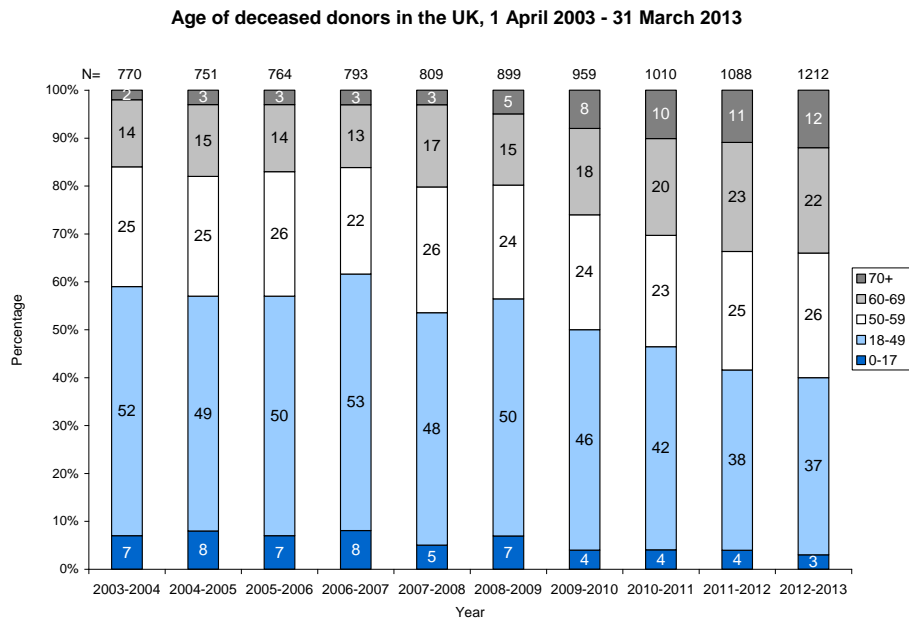

Source: Transplant activity in the UK, 2012-2013, NHS Blood and Transplant

Figure 1-2: Trends of organ donation in the United Kingdom; the average donor age is increased over past ten years and majority of the organ donor pool is over 50years of age

In addition to the age, the body mass index of an average donor is rising (Koneru and Dikdan 2002). Compared with those figures a decade ago the donors with body mass index over 30 kg/m² has nearly doubled in the United Kingdom (figure 1-3) and this has significant impact on the quality of liver grafts procured for transplantation. Both the age and body mass index collectively considered characteristics of a marginal donor, and included in most of the risk assessment models of liver transplantation (Feng et al. 2006). Although the organ donation activity is rising in the United Kingdom, probably a substantial number of donors accounted for this increase is comprised of these marginal donors and this evident by the discard of 15% of liver grafts procured from the DBD donors alone.

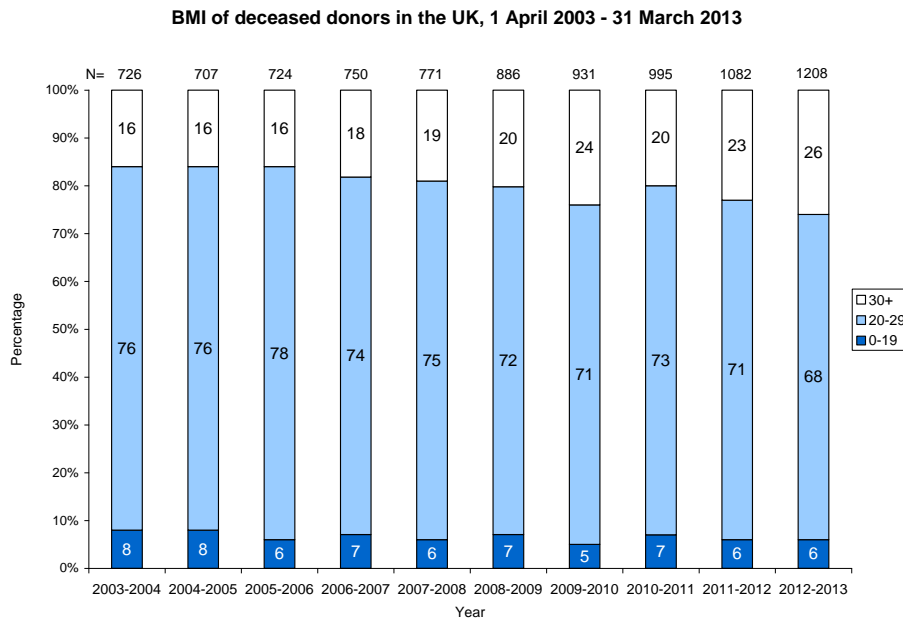

Source: Transplant activity in the UK, 2012-2013, NHS Blood and Transplant

Figure 1-3: Changing demographics of organ donation in the United Kingdom; there is progressive increase of organ donors with BMI over 30 denoting significant proportion of donors are likely to be marginal

1.5 Graft steatosis

Graft steatosis predicted the survival of the allograft following transplant and closely linked to the amount of steatosis present in the graft (Angele et al. 2008; Marsman et al. 1996). Steatosis is widely prevalent in the population and could be present in two major forms. Macrovesicular steatosis, the presence of larger fat globules within a hepatocyte usually replaces the cytoplasm is considered a more chronic and longstanding process. The other form microvesicular steatosis signifies the presence of small fat droplets scattered within the cytoplasm and could be considered more acute changes reflected by acute changes in the health, infection or sepsis, malnutrition and considered transient changes (Cieslak et al. 2009). Both macro and microvesicular steatosis are graded according to the degree of severity of its presence within the hepatocytes. When fatty change is present in 10% cells in a high power field the graft is termed minimal change or non-steatotic grafts. Mild, moderate and severe steatosis denotes 10-30%, 30-60% and over 60% presence of

steatosis of the graft and this classification is generally used for both types of steatosis.

Macrovesicular steatosis is a known risk factor for liver allograft failure, and the impact from microvesicular steatosis alone is considered not significant as an independent predictor (Salizzoni et al. 2003). Generally the moderate or severe steatosis is associated with over 30% risk of graft failure following liver transplantation (Marsman, Wiesner, Rodriguez, Batts, Porayko, Hay, Gores, & Krom 1996). Macrovesicular steatosis also does impact independently on graft function immediately after transplantation; the degree of steatosis is directly proportionate to graft dysfunction (Perez-Daga et al. 2006). Moreover, macrovesicular steatosis may interact with other variables of the donor. For example, a mildly steatotic graft from an elderly donor may act in synergistic manner and the outcome following transplantation may be worse than that of a moderately steatotic liver from a younger donor (Busquets et al. 2001). The decreased plasma membrane fluidity in the sinusoidal lining cells after cold storage has been postulated as the mechanism of injury causing liver dysfunction attributable to graft failure (Fukumori et al. 1999). The organ discard rate after procuring with intention to transplantation is increasingly high due to the presence of steatosis. As discussed previously most of these donors consist of elderly or obese donor population which is a significant problem faced by transplant surgeons. Despite the results of steatotic liver grafts are known to be poorer than the healthy liver grafts, the transplant surgeons are compelled to the use these grafts in a more selective manner to relieve burden on transplant wait list (McCormack et al. 2007).

The use of steatotic grafts in liver transplantation with success was partly related to the progressive attitude of transplant surgeons willing to push the boundaries (Imber et al. 2002; Mirza et al. 1994) and accept graft offers deemed unsuitable for transplantation by others. The data generated through this approach has other centers explore the maximum utility of donor organ pool (Verran et al. 2003). Furthermore, characterization of degree of graft dysfunction based on traditional biochemical criteria helped differentiate early poor outcomes and more intensive

management of patients receiving these grafts (Tekin et al. 2004). Various scoring systems have been developed to describe the marginality of a donor allografts and almost all of these incorporate graft steatosis (Axelrod et al. 2007; Dutkowski et al. 2012); however apart from retrospective comparison of experience between difference transplant programs etc, the real time utility of these scoring systems in the actual day to day decision making is limited.

1.6 Donation after circulatory death

Organ donation after circulatory death (DCD), also previously known as non-heart beating donation is not a new concept in the field of organ transplantation (Kootstra 1997) and at the beginning of this chapter introduced that historical attempts of experimental organ transplantation were carried out with organ procured from cadavers. Even prior to the era where concepts of organ preservation was introduced, experiments involved transplantation of organs from cadaveric donors, and not surprisingly the transplant operations carried out with these “post-mortem” organs did not succeed. The initial outcomes may have been hindered by the inferior quality of these grafts, because the cessation of circulatory function is associated with abrupt cessation of metabolic functions within of the cells within a tissue, with eventual energy exhaustion and widespread cell death or necrosis.

The practice of organ donation from DCD donors faded during the 1960's and 1970's and the organ donor pool during this era primarily consisted of DBD donors. By this time transplant professionals had refined and gained a significant experience in liver transplant techniques. The improved quality of life gained by liver transplantation attracted the interest and the better outcomes were convincing enough to attract more and more patient referrals, and relaxation of indications for liver transplantation as discussed earlier in this chapter. The ultimate result was the expansion of transplant wait lists with patients listed, whilst the donor organ pool did not expand at the same rate despite wider practice of brain stem death or determination of neurological death. Consequently, DCD liver transplantation was revived in the late 1990's in this backdrop of donor organ shortage (Abt et al.

2004; Muiesan et al. 2005). With improved organ preservation techniques in place, DCD grafts were procured from donors who were pre-identified and under tight conditions (D'Alessandro et al. 2000). Generally potential DCD donors also included those who suffered major neurological injury not severe enough to make a diagnosis of brain stem death or that these neurological events were so recent that the usual pathophysiology and brain oedema had not fully evolved. These patients do not meet the criteria for determination of neurological death, and on the other hand continued life support or neurosurgical interventions are unlikely to improve the condition either. Further treatment in these patients is therefore deemed futile, and a clinical decision is taken by the attending physicians to withdraw life supporting treatment. Once life support is withdrawn these patients progress to eventual circulatory arrest and cardiac function ceases (Ridley et al. 2005). Cessation of cerebral circulation is vital for the eventual neurological death, due to the lack of blood and oxygen supply to the brain. Cerebral circulation is absolutely vital for the life as the research suggests absence of cerebral circulation for more than 2-3 minutes is associated with irreversible neuronal injury and death. In these donors therefore a standard five minutes period, termed as "obligatory stand-off time" is allowed for the neurological death to ensue (Reich et al. 2009). Confirmation of death is by traditional criteria and thereafter it allows a legal and ethical framework of organ procurement for transplantation.

There has been a steep rise in organ transplant activity with organs from DCD donors worldwide (Moers et al. 2007; Reich et al. 2000). In the United Kingdom alone, the DCD organ donation activity increased by many-folds in the recent years, this undoubtedly contributed to the increased transplant activity seen over the years. Despite this, there are certain issues that surround the DCD organ donation that limits the best utility of the DCD grafts. The origin of most these problems is the basic difference between the two key types of organ donation processes. In DBD donation, the donor is confirmed brain dead by neurological criteria, therefore intervention to facilitate donation is allowed; therefore donor operation could begin with and warm phase dissection and mobilisation of organs could be carried out before finally the organ support is withdrawn. Even the administration of medication

with the view of preservations of organs in the best possible state is legally and ethically allowed in this case scenario. In DCD donors however, treatment is withdrawn prior to the death, and indeed this is the process that allows natural passage in to the death of a prospective DCD donor. In most circumstances the donors linger in a phase called “agonal phase” before the cardiac death ensues and no intervention is ethically or legally allowed during this period.

1.6.1 Donor warm ischaemia

The donor warm ischaemia refers to an ischaemic insult to the organs of a potential donor, once life sustaining treatment is withdrawn (Hoshino et al. 1988). As discussed above, in many of prospective DCD donors, perfusion of the vital organs is maintained by intense management aimed at maintaining the adequate perfusion by means of vasopressors and oxygenation through mechanical ventilation. Without these, hypoxaemia and hypotension ensue and the tissues undergo ischaemic damage of varying degrees, and these become the usual preceding events following treatment withdrawal in a patient. The cells continue metabolism at body temperature, but the lack of oxygenated perfusion makes these cells prone to ischaemic damage. The degree of damage depends on the time exposed these cells or the tissues to warm ischaemia (Takada et al. 1997).

In DCD donors after treatment withdrawal, the time taken to circulatory death is variable, and unpredictable. Dependency on higher level of organ support probably makes the progression to circulatory death quicker once the life supportive treatment is withdrawn. In some other patients despite being on significant amount support prior to withdrawal, eventual progression to circulatory death may be prolonged. Transplant professionals do not have any access for donor management or intervention during this variable period and this is protected by the ethical and legal guidelines surrounding organ donation. Therefore it is important to select DCD donors that only progress to circulatory death within a pre-defined time frame, proven by the animal, clinical and laboratory data where procurement and

transplantation of organs from such donors are proven to be a success. Transplant surgeons therefore have set time limits to accept organs dependent on the ischaemic susceptibility of the various organs in the body. In liver transplantation the general rule is to accept 30 minutes of donor warm ischaemia and the outcomes of grafts with donor warm ischaemia beyond 30 minutes are significantly inferior with increased risk of graft failure rates (Takada, Taniguchi, Fukunaga, Yuzawa, Otsuka, Todoroki, Iijima, & Fukao 1997).

The implications of donor warm ischaemia could be disastrous in some cases, and also in a group of patients after liver transplantation the long term morbidity could be the result of damage caused by donor warm ischaemia to the grafts. Primary non-function or immediate graft failure is significantly higher in the DCD liver transplantation and the clinical data from all the large centers report donor warm ischaemia is directly attributable to primary graft failure (Strasberg et al. 1994). The biliary tree receives its blood supply solely from the hepatic artery through a rich vascular complex called peri-biliary vascular arcade. Lack of oxygen delivery to the bile ducts during the donor warm ischaemia period makes these bile ducts susceptible to ischaemic injury and the damage is manifested as ischaemic type biliary lesions in the post operative period (Heidenhain et al. 2010).

Ischaemic type biliary lesions (ITBL) represents a wider spectrum of pathology ranging from isolated short segment biliary strictures to more widespread and global damage to the bile ducts (Abt et al. 2003). Although the donor warm ischaemia is primarily responsible for the ITBL, other causes are hypothesized, such as bile salt toxicity (Buis et al. 2006; Buis et al. 2009), immunological damage etc (Rull et al. 2001). In its milder form of the spectrum, these could be managed conservatively with minimal intervention or surgery, however more serious forms of involvement of the bile ducts necessitate a re-transplantation without which the quality of the life of recipients is poor. This is one major obstacle faced by transplant surgeons at present selecting the best liver grafts that would not lead to the development of ITBL, because this complication may put extra burden on the system where the demand for organs for first time transplant itself is very high, and the addition of more patients

requiring re-grafts or re-transplantation adds further burden to the system (Foley et al. 2011).

1.7 Graft preservation

The history of organ preservation dates back to mid 20th Century and progress that has been made constitutes the backbone of the success of solid organ transplantation (Belzer and Southard 1988). Explanted organs are no longer connected to the circulation and this result in impaired oxygen delivery, along with impaired nutrient delivery and removal of metabolic waste products. Research related to organ preservation has undergone phases over the decades and static cold storage has been currently the universally accepted technique of organ preservation. Cooling down the tissues are known to reduce the metabolic demand of the cells within, therefore the intracellular enzymes that function at optimal body temperatures would become less active, thus the energy dependent systems become less demanding (Southard 1999). This principle was introduced in 1960's and it was proved that internal cooling is far more effective than topical cooling alone, and both internal and external cooling could achieve rapid cooling of the tissue rendering them less metabolically active during the time these organ come out of donors' body cavity and until the circulation is restored.

1.7.1 Cold ischaemia

Static cold storage upon organ procurement and transfer until these are transplanted has been in practice as the gold standard of organ preservation over the latter part of the 20th Century. Although recent studies suggest normothermic preservation may be more superior to cold preservation and this emerging data may re-shape the practice of the organ transplantation practice in the future (Brockmann et al. 2009; McLaren and Friend 2003). Tissue cooling is effective and a cheaper way of preservation and maintaining the viability of organs. Each 10⁰ C drop in the tissue temperature is known to reduce the metabolic activity by 50% and therefore cooling achieved at 0-4⁰ C may reduce the intracellular metabolic activity down to 10% of the baseline (Belzer & Southard 1988). This degree of metabolic activity is sufficient

to maintain the cells alive, however the duration of cold ischaemia tolerated by different organs and cell types vary. For example cardiac muscle tolerates the least duration of cold ischaemia that does not exceed 6 hours, and unless the grafts are transplanted within this time frame primary graft failure ensues. In liver transplantation the cold ischaemia time is a modest period, but this again varies with the quality of the graft. A non-steatotic liver graft from a healthy young donor may tolerate a cold ischaemia time up to 16-18 hours and in case of a marginal or steatotic graft this would be much shorter (Yoglu et al. 1988).

Several organ preservation solutions have been introduced, and historically all of these solutions contain electrolytes composition similar to that of the intracellular environment. The basic composition of the organ preservation solutions consisted electrolytes, energy source usually of elemental that feeds directly in to the ATP generating mechanisms within the cell, buffer solution to counteract the acidaemia that builds up in an organ during ischaemia, basic and essential amino acids and antibiotics. The composition of these solutions has been designed with the understanding of the metabolic pathways and molecular mechanisms. Among the preservation solutions available in the market at present University of Wisconsin solution (UW solution) is considered the gold standard (Koning et al. 1997). Liver grafts preserved with UW solution are known to be associated with less ischaemia reperfusion injury and better organ preservation compared with other solutions (D'Alessandro et al. 1991; Mangus et al. 2006). Sometimes these solutions may be used in combination; especially in case of liver graft perfusion that allows dual perfusion through the hepatic artery and the portal vein. Five commonly used organ preservation solutions include UW, Euro-Collins, Celsior, Custodial and IGL-1 solution. Hyperosmolar Citrate or HoS is a low viscosity solution, also known as Marshal's citrate solution primarily used in renal graft preservation, however may be used in liver preservation when used in combination with a superior preservation solution as mentioned above.

1.7.2 Preservation-reperfusion injury

Preservation-reperfusion injury (PRI) is a term applied to describe the pathological changes in an organ injury following the restoration blood supply in the new host (recipient) (Serracino-Inglott et al. 2001). These complex changes are the result of oxygen radical induced organ injury, characterized by the increased microvascular permeability and hemorrhage in to the tissue parenchyma, tissue oedema and variable degree of cellular injury (Jaeschke et al. 1990). Despite diminution of intracellular metabolism during the cold preservation, the cells continue to consume intracellular ATP for the maintenance of essential intracellular functions that including maintenance of integrity of the cell membrane and mitochondria. Depletion of intracellular ATP cause breakdown of adenosine and mitochondria causes accumulation of chemical substances which could act as free radicals when the tissues are re-oxygenated (Jaeschke 2003).

Free radical induced tissue injury further aggravates the damage by the release of cytokines. The increased microvascular permeability and hemorrhage in the tissues brings in neutrophils and macrophages in to the tissue which act synergistically control the tissue damage (Fondevila et al. 2003). The pathophysiology involves the release of the cytokines in to the systemic circulation and distant tissue damage is also occurring during the reperfusion of a graft, and this phenomenon is termed "reperfusion syndrome" (Goode et al. 1994). Preservation-reperfusion injury and reperfusion injury is correlated with the degree of organ damage during cold preservation (Reddy et al. 2005). Severely ischaemic grafts would be associated with severe PRI and reperfusion injury and in well preserved grafts these effects are less severe. In severe forms the PRI could cause lethal injury to the graft causing immediate or primary graft failure, and the release of massive load of cytokines and free radicals in to the circulation via returning venous drainage could lead to immediate cardio-vascular and systemic instability to the patient. Furthermore, end organ damage, primarily the renal injury is ensued in case of liver transplant recipients. The data from liver transplantation suggests that acute kidney injury and

renal failure is common after the use of liver grafts from marginal donors including those from DCD donors.

1.8 Primary non-function

Primary non-function (PNF) is a clinical entity encountered in liver transplantation, as well with other solid organ transplants. This is also termed as initial poor function (IPF), and describes the failure of the transplanted liver graft to restore the function once the blood supply is re-connected surgically. In liver transplantation PNF is seen in up to 2-10% of cases and the incidence varies with the graft types and the quality of the organs transplanted (Strasberg, Howard, Molmenti, & Hertl 1994). Liver grafts from DBD donors has a lower incidence of PNF up 2-5% meanwhile that from DCD liver grafts may be doubled and reported in up 8-15% cases. In liver transplantation PNF is a more serious complication, because the recipient life is in danger in this situation and the only survivable option for these patients is an immediate re-transplantation of the liver graft.

The exact aetiology of PNF is unknown; however the pathological studies of the explanted failed allografts showed the widespread hepatocytes necrosis and sinusoidal haemorrhage (Gonzalez et al. 1994). Severe PRI is attributed to these changes and known risk factors for such severe injury are known to be prolonged cold preservation or cold ischaemia time, graft steatosis, usually moderate to severe macrovesicular steatosis, elderly donor grafts etc (Ploeg et al. 1993). Grafts from DCD donors, as discussed above have been exposed to added donor warm ischaemia prior to the start of cold storage thus tolerate only less period of cold ischaemia. Therefore attempts are made to transplant the liver grafts from DCD donors within a shorter time frame. Clinicians are aware of these risk factors causing PNF however despite the best efforts to choose the grafts from donors that are likely to function normally in the recipient, PNF occur as a surprising event and in most cases unpredictable. It is also important to discuss that the PNF is not entirely graft related and the recipient environment also play a significant part in the occurrence of this complication

(Markmann et al. 2001;Schaubel et al. 2008). Extremely sick patients with physiological disturbance may not tolerate a marginal liver graft that would function normally in a recipient with stable physiology, and this complicates the life of a liver transplant surgeon. Careful donor-recipient matching is a clinical skill that transplant surgeons master through the years of experience.

Transplant surgeons usually make clinical decisions based on the predictability of graft function, influenced by variety of information passed on to them at the time of donor organ offering. Age, previous medical history, immediate pre-donation medical condition and laboratory findings, especially the liver function status and general physiology of the donor at the time of organ offering heavily influence the decision making and every effort is made to choose functioning grafts (Hoofnagle et al. 1996). The unpredictable nature of PNF is exemplified by the graft failures despite attention to the details (Marino et al. 1995). Younger and previously healthy donor liver grafts are no exceptions (Todo et al. 1989;Wall et al. 1990).

Whilst PNF has serious consequences to the recipient, because without a life saving emergency transplant within a very short period of time the hope for survival is almost zero, there are other aspects which affect many other prospective transplant recipients in the wait list. In the PNF situation allocation of another liver graft on priority basis, as allowed by almost all transplant allocation systems means that the donor organ pool is minus one further liver graft that could have potentially saved the life of another patient given there was no PNF situation. Although incidence of PNF low, these situations consume number of good quality liver grafts from a national donor organ pool. Combined with the current situation of organ scarcity PNF is an added pressure on the system.

1.9 Biomarkers predicting graft function

It appears from the above discussion that currently there is a significant organ shortage of liver grafts despite attempts to bridge this gap with marginal grafts. Currently no investigation could accurately predict the organ function following

transplantation; therefore many of these marginal organs are rejected outright. As reported by the pioneers of liver transplantation through their early experience, a significant proportion of grafts that were considered “good” in quality had resulted in poor graft function after transplantation (Makowka et al. 1987). Also no investigation that could predict primary non-function of the liver grafts has been developed and the quality assessment of a liver graft is determined by the routine liver biochemistry, donor past and current medical history and combination of macroscopic and microscopic examination of liver graft in some cases. The liver biochemistry may be normal whilst the graft is still in the donor environment, but these do not reflect the interim physiological changes whilst the organs are procured and preserved in the static cold storage. The macroscopic and microscopic examination may be acceptable however, the exact extent of PRI will not be known until the graft is perfused in the recipient, and by this time the surgical steps have gone too far to the extent of point of no return. Those traditional methods of organ assessment or the clinical expertise combined with these alone do not prevent PNF of liver grafts. This creates a room and a need for novel biomarkers that would predict PNF of liver grafts at various stages of the journey of an organ in the process of liver transplantation. Perhaps these biomarkers may be present in the donor, and if tested positive a more cautious approach may be employed in selecting those liver grafts for transplantation. Or else the grafts could be tested at the end of the cold storage before implantation or even after implantation and the presence of these biomarkers predicting PNF may open up avenues for further research in mechanisms to modify the pathophysiological sequelae through intervention.

CHAPTER 2 RESEARCH HYPOTHESIS AND STUDY PLAN

2.1 Research aim

Conventionally, the immediate success of a transplanted liver allograft is assessed by a combination of clinical and biochemical criteria. In the presence of immediate poor graft function or PNF the recipient haemodynamics and physiology deteriorate significantly (Koffron and Stein 2008). Usually this is seen as prolongation of the reperfusion syndrome that is manifested only in a proportion of such patients. Lactate clearance and correction of acid base imbalance are other parameters that could be used with real time blood sampling. Other biochemical and haematological investigations also performed routinely in transplanted patients and these include serum alanine and aspartate transaminases, prothrombin time and serum bilirubin (Tekin, Imber, Atli, Gunson, Bramhall, Mayer, Buckels, McMaster, & Mirza 2004). High serum transaminases levels are generally considered to be reflective of the severity of graft injury during the ischaemia and reperfusion. Inability of the liver graft to resume immediate function results in lack of coagulation factor production leading to prolongation of prothrombin time (Pokorny et al. 2000). Bilirubin is also a surrogate marker of allograft injury. Whilst PNF could be diagnosed when all these clinical features and biochemical findings considered together, an isolated rise of a single enzyme or presence of recipient instability do not help clinical decision making, as these could be the result of many other physio-chemical processes.

The studies outlined in this thesis were aimed at identifying metabolic differences and changes between cadaveric liver grafts used in the clinical liver transplantation setting, from cold ischaemia to reperfusion, using several novel techniques. The specific objective was to identify the key differences between the DCD and DBD liver grafts, with the possibility of identifying biomarkers predictive of graft function. This was in the background of real shortfall of organs available for liver transplantation in the UK with approximately 20% of patients on the waiting list dying due to delay in

receiving a suitable graft as discussed in the previous chapter. In the United Kingdom and other Western countries, many transplant centres currently use liver grafts that are considered sub-optimal for transplantation in an attempt to increase the donor pool. These sub-optimal or marginal grafts however have a higher tendency to function poorly in the recipient post transplantation leading to initial poor function or primary non function that could lead to re-transplantation or death of the recipient. Therefore this project was designed with aims of understanding the metabolic changes that occur in a liver graft during the process of transplantation. Identifying these biomarkers would help further research on therapeutic intervention on the grafts with unfavourable biomarkers predicting poor function; furthermore this approach would also help in better graft recipient matching, and understanding interventional processes designed to optimize grafts has the potential to increase the donor pool while making the utilization of a scarce resource better.

Birmingham Liver Unit has developed the technology needed to use the technique of microdialysis (Silva et al. 2005; Silva et al. 2006a) in the setting of liver transplantation through real time analysis of the metabolic changes that occur within the graft during the donor operation, while in cold storage and immediately post transplantation. Using targeted analytical platforms previous studies have shown that microdialysis can study the changes within the graft safely, is able to differentiate between grafts that function well post transplantation, and has the ability to study specific metabolic pathways. The current studies were focussed on the use of this tried and tested method with different and novel analytical platforms so as to study the whole metabolome in order to identify specific metabolic signatures that will then be identified in more easily accessible biologic material like liver biopsies and blood samples. At the outset we envisaged that this project therefore has real potential in producing results which will translate to data that will have clear clinical benefits.

The specific aim of this research was to investigate metabolic differences of the liver grafts obtained from DCD and DBD donors. We hypothesized that the changes in the intracellular metabolome in the process of preservation-reperfusion injury would be reflected in the extracellular fluid, through the transfer of these metabolites across

the cell membrane of the hepatocytes, hence the extracellular tissue fluid sampling would enable identify these biomarkers through various metabolomic analytical platforms.

The Liver Unit at the University Hospital Birmingham is one of the largest liver transplant centres in Europe with approximately 190 – 200 adult liver transplants carried out each year. This high turnover made the setting ideal to carry out this study. The experience the liver unit has with the use of microdialysis in the liver transplant setting is also a plus factor since theatre, intensive care and ward staff are familiar with its use. The Liver Laboratories, Institute of Biomedical Research, University of Birmingham is also housed in close association with the Liver Unit making running of the project easy.

2.2 Research proposal

Figure 2.1 below depicts the routine sequence of events from the donor operation until the organs are transplanted in the recipient. Typically the time sequence of the events could take up to 24-48hours from the time of form the identification of a suitable organ donor through to organ procurement and cold storage until the organ transplantation is completed in the suitably matched recipient. The study was designed as such that the metabolite changes during the entire process could be studied. We proposed a combination of sample collection protocol to include the donor, cold storage and recipient phases so that the serial changes that occur in a particular metabolite could be studied longitudinally.

Primarily the sample protocol involved the microdialysis sampling of the liver parenchyma to obtain pure tissue fluid samples, liver allograft biopsy and serum samples from both the donor and the recipient at corresponding time intervals simultaneous to the microdialysis samples. However, as the study was run through, concerns were raised by interested parties on the suitability and ethical aspects of collecting the samples from a donor therefore after limited number of sample

collection from the DBD donors, the donor phase sampling was abandoned. This was felt appropriate, as in case of DCD donors' practical difficulties arose with microdialysis sample collection owing to the rapid nature of surgical steps leading to organ procurement, as outlined in the chapter 1 and below.

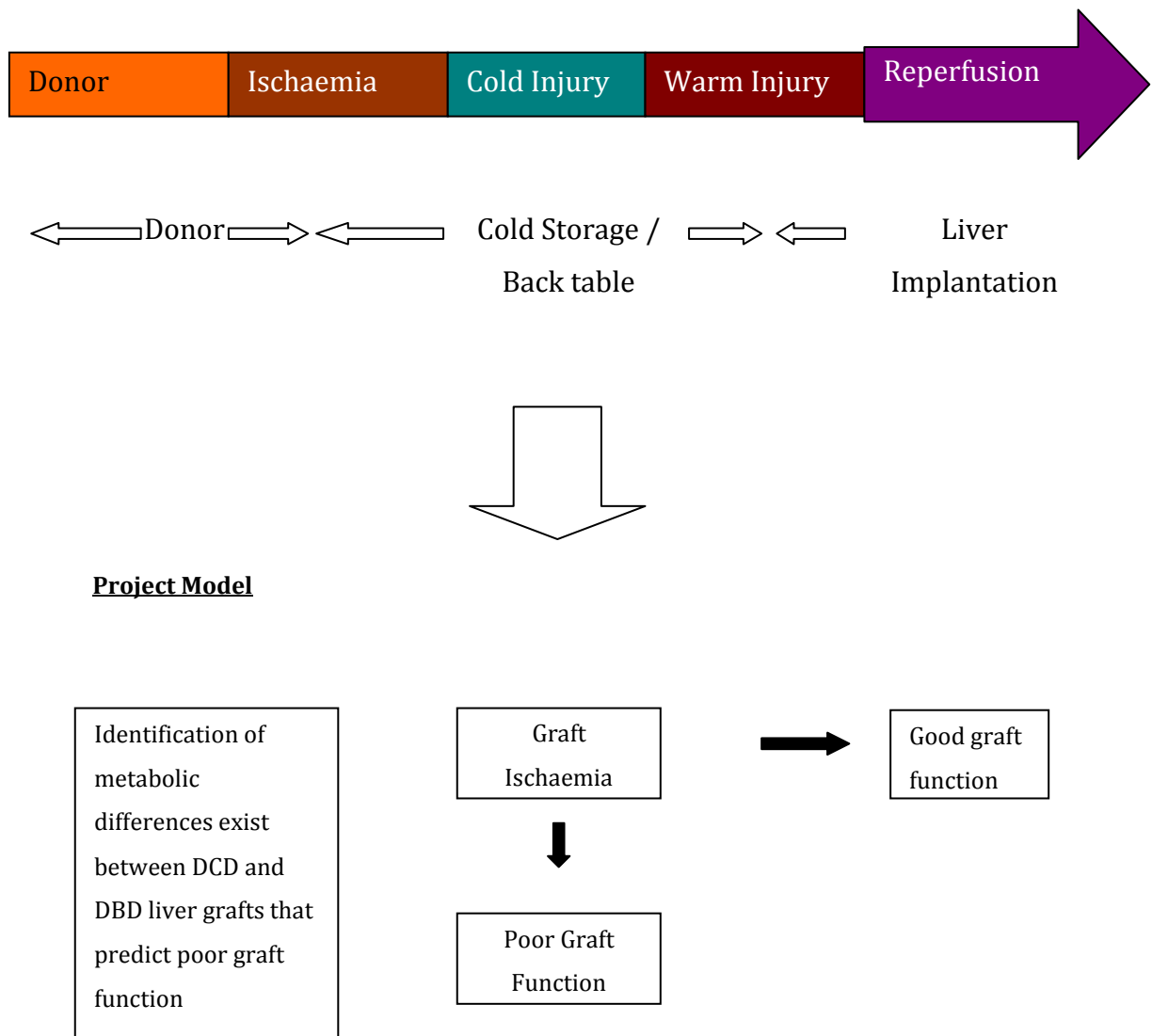

Figure 2-1: The processes involved in the liver transplantation from the donor to the recipient; graft ischaemia is inevitable outcome leading poor or good graft function providing space for the investigation of metabolic differences between these two outcomes

2.3 Study design

2.3.1 The donor operation

The principles of donor operation for organ procurement involves identification and preparation of the abdominal descending aorta for cannulation and institution of the cold preservation solution, and isolation of the abdominal aorta to confine the perfusate to circulate only through the visceral blood supply. This is achieved by cross clamping the abdominal aorta at the diaphragmatic hiatus at the beginning of the cold perfusion. Outflow venting is the third essential key component in abdominal organ harvest which done by opening the abdominal and thoracic inferior vena cava within the pericardial sac. Although these three principle steps are the essential steps in organ procurement from deceased donors, various other surgical steps are undertaken and this is determined by the nature of the organ donation.

In donors after brain death (DBD), the organs are perfused with intact circulation hence ample time is available for the donor surgeon to mobilize the intra-abdominal viscera intended for transplantation (Brockmann et al. 2006). This is termed as warm phase dissection that is aimed at isolation of the individual blood supply to the respective organs. The advantage of this technique is the positive identification of vascular anatomy, allowing abnormal anatomy to be recognized, thereby minimizing unwanted injury to these vessels (Baranski 2009). Early practice of organ donation differed from this approach in that organs were procured en-bloc and separated in an ice bath; as organs are without blood supply at this stage, positive identification of structures is difficult the chances of causing injury to blood vessels was higher. Loss of orientation anatomy further increased the chances of inadvertent injury. In current DBD organ donation practice thus organs are mobilized prior to aortic cannulation and eventual cross clamp, spending a variable time period of warm dissection depending on the experience of the organ retrieval surgeon. The common bile duct is divided just above the duodenum and the bile is flushed through the opening made in the gall bladder prior to the institution of the cold preservation solution heralds the cold ischaemic preservation.

The situation is technically more demanding in donors after circulatory death (DCD) wherein “circulatory” death is confirmed prior to the beginning of the donor operation. Therefore no time is spent on mobilizing organs in a warm phase, as each minute passed further aggravates the warm ischaemic injury to the organs. The aim is therefore rapid laparotomy and cannulation of the aorta followed by the adherence to the key steps in basic organ donation surgery. This technique is often termed “super-rapid” technique of organ procurement and the objective is to minimize the warm ischaemic damage and initiation of cold preservation at the earliest possible time point (Fong and Blumgart 2000).

As the liver receives a double blood supply through the hepatic artery and the portal vein, a dual perfusion system is used in the majority of the cases of liver graft retrieval with rare exceptions. Whilst the hepatic artery is perfused through the aortic cannula, the superior mesenteric vein is identified and cannulated to perfuse the graft with further organ preservation solution. This dual perfusion ensures maximum volume of organ preservation solution reaching the hepatocytes, and adequate microvascular flush thereby achieving better cellular preservation. In our practice we used Marshall’s hyper-osmolar citrate solution to perfuse the aorta and University of Wisconsin solution to perfuse the portal vein with 4 and one liters respectively. Marshall’s solution has been introduced as a kidney preservation solution and was choice of solution owing to low viscosity and the cost. Viscosity of a preservation solution is a key indicator for the effectiveness of organ preservation solution (Guarrera and Karim 2008); higher viscosity solutions cause diminished microvascular flush. This in turn leads to longer cold flush times and inadequate organ preservation. Microvascular hypo-perfusion leads to increased incidence of biliary complications in liver transplantation (Maheshwari et al. 2007). Marshalls’ solution therefore is an ideal solution in the donation after circulatory death setting where micro-thrombus formation post mortem has been already initiated. Our practice of using Marshalls’ solution was different to many other liver transplant centers which used University of Wisconsin solution for aortic perfusion which deemed to yield better organ preservation and increased cold preservation times based on randomized controlled studies.

Once perfused with the cold preservation solution, liver grafts were retrieved with intact hepatic arterial supply, portal vein and the bile duct in the hepatic hilum, along with the retrohepatic inferior vena cava. These grafts were then perfused in the back bench – with University of Wisconsin solution 500 and 250cc through the portal vein and the hepatic artery respectively before being packed in double sterile bags. Residual bile is more likely to be inspissated in the cold temperature, and if not removed may solidify to form biliary casts in the recipient. Therefore bile duct is also usually flushed to remove any residual bile. The liver graft is then safely placed in an ice box for transport.

2.3.2 Liver transplantation technique

Macroscopic appearance of the liver graft is a crude assessment of the degree of steatosis; however this is practiced through generations. Generally this information is gathered from the organ retrieval surgeon but examination of the liver graft prior to commencement of the recipient transplant operation is a more reliable form of organ assessment as often experience of the surgeon assessing the organ is counted. Size of the liver graft, colour, margins and the consistency are key elements of assessment. Larger liver grafts with yellow appearance, often with rounded edges as opposed to sharp edges denote a fatty liver, whereas a firm graft texture may suggest steatosis or fibrosis as well as inadequate / suboptimal preservation. A careful and reasonably accurate assessment by the experienced recipient surgeon is possible through macroscopic appearance alone that could be performed once the liver graft is taken out of ice at the implanting centre. In doubtful cases, rapid processing of a liver biopsy specimen is requested to quantify the degree of steatosis before making a final decision on transplantability of the organ.

The liver transplantation technique that is commonly described as the modified piggyback technique was followed in all cases that we studied. In brief, this included laparotomy and entry in to the abdominal cavity. Hilar dissection with division of the bile duct, hepatic artery and the portal vein followed and a temporary port-caval shunt was performed in the majority of cases. Complete posterior mobilisation of the

liver whilst preserving the native vena cava is required for the modified piggyback technique, hence ligation and division of individual hepatic veins was mandatory. Mobilisation and explantation of the native liver is completed by taking the right hepatic vein and the left/middle hepatic veins as a common trunk. The liver graft prepared in the ice bath is taken out for implantation and this time point signifies the end of the cold ischaemia. As the liver graft is exposed to the room temperature during the implantation procedure until blood supply is restored, this period of re-warming is termed as warm ischaemia, and the time lag between the graft taken out of ice and reperfusion with the recipients own blood is termed the implantation time. The first anastomosis to be performed is a creation of venous outflow by way of a side to side cavo-cavoplasty. Here a large opening made between the graft and the recipient cava is sutured together to allow free venous return of the hepatic venous blood. In the next step the portal vein of the recipient is directly anastomosed to the graft portal vein, at the end procedure the graft is flushed with a physiological solution to get rid of excess potassium from the graft. This excess potassium is the result of organ preservation solution, as well cell lysis; if not flushed, a massive load of potassium is released to the circulation during reperfusion, causing immediate cardiac rhythm abnormalities and even cardiac arrest on table. Both vena caval and portal venous anastomoses are completed once the flush out with physiological saline is complete.

Liver grafts are reperfused with portal venous blood first, before the commencement of hepatic arterial anastomosis. The objective behind this rationale is to minimize the warm ischaemic injury during the reperfusion phase. Caval and portal clamps are released to reperfuse liver graft with blood and significant haemodynamic changes are anticipated in this stage. Sudden release of cold blood passage through the liver graft entering circulation, combined with the release of cytokines and other chemo mediators of cell damage, excess potassium all contribute to these haemodynamic changes which are collectively termed as “reperfusion syndrome”. As the new liver allograft should start to function in the recipient’s body but this immediate function may be determined by the degree of organ damage during brain or circulatory death in the donor and subsequent cold storage. In addition, further injury to the graft

occurs during the reperfusion through activation of oxygen free radicals and Kupffer cell mediated reperfusion injury.

The hepatic artery anastomosis between the recipient and graft is carried out next, and restitution of oxygenated blood to the graft could cause further reperfusion injury. This step permits the graft to be fully oxygenated and also achieves perfusion of the arterially supplied biliary tree. The final anastomosis is carried out to ensure biliary drainage, through the native bile duct or by creation of a Roux en-Y hepaticojejunostomy. A surgical drain inserted at the end of the operation helps monitor ongoing bleeding, and provides drainage for excessive ascites once the abdomen is closed

2.4 Microdialysis

Microdialysis is a technique of interstitial tissue fluid sampling using the principle of solute transfer across a semi-permeable membrane across a concentration gradient. This technique mimics the transfer of solutes across a thin capillary blood vessel and originally described in experimental animal and human models involving neurosurgery and subsequently used as a research tool involving various organs (Nilsson et al. 1999). The technique involves an insertion of a specially designed microdialysis catheter and embedded in the tissue, and a battery driven syringe pump which pumps a physiological solution. The pump is designed in a way that the microdialysis fluid pumped in to the tissue could be controlled via a variable flow rate, and the returning fluid after equilibrium in the tissue space is returned and collected at the outside body by a microvial. The benefits of using microdialysis in combination with metabolomics are two-fold; the major advantage of microdialysis is known to be due to the purity of the sample as blood is not in contact with the fluid hence sample preparation is not necessary. It therefore does not require laborious methods of solid phase extraction for analysis. Additionally, the microdialysate is relatively organ specific and does not have metabolites from other organ systems which can confound data analysis. CMA Microdialysis Stockholm, Sweden is the only supplier of microdialysis consumables which are licensed to be used in humans.

2.4.1 Microdialysis in liver transplantation

Microdialysis has been applied as a research tool in both experimental and liver transplantation setting of both animal and human studies. Whilst the majority of the studies were focused on graft monitoring, including those from our own research group, the technique has been used to monitor the distant organs during the process of liver transplantation. The earliest studies investigated the basic energy substrates and metabolic end products of pig liver transplantation model involving donor operation to cold ischaemia and reperfusion and documented the changes in lactate, pyruvate, glucose and glycerol levels in the perfusate (Nowak et al. 2002a). Going further the same group studied the metabolic changes in the human model and reported reducing lactate levels post reperfusion and stabilization of pyruvate levels during the first 24 hours of transplantation. Glycerol is an abundant glycolipid in the cellular membranes and increased glycerol levels in the extracellular tissue space is correlated with the degree of cellular injury (Nowak et al. 2003a). The same study reported that the liver grafts used in liver transplantation had higher levels of glycerol and these gradually reduced over the period up to 24 hours after the reperfusion. This finding denotes that graft injury is immediate after the reperfusion and with time the tissue injury becomes less severe after transplantation (Nowak et al. 2002b). In a case report, microdialysis as an investigation tool to monitor the extra-hepatic organs was demonstrated when the investigators implanted a microdialysis catheter in the brain in a patient undergoing liver transplantation for acute hepatic failure. The authors in this case demonstrated changes to neurochemistry, more specifically a rise in intracerebral lactate levels without any evidence of changes in cerebral perfusion pressures, denoting lactate flux from systemic circulation to the cerebral circulation that correspond to the changes that occurred in the systemic circulation during the process of transplantation. These along with other neurotransmitter changes suggest that microdialysis is a valuable tool not only in the investigation of grafts of interest, but also distant organs where the direct effects of graft dysfunction may have implications for.

Previous studies involving the clinical transplant model from our own group demonstrated basic energy metabolite changes similar to those reported by other studies (Silva, M.A., Murphy, N., Richards, D.A., Wigmore, S.J., Bramhall, S.R., Buckels, J.A., Adams, D.H., & Mirza, D.F. 2006b). In addition these studies examined the changes to the selected amino acids during the process of reperfusion and documented that reduced levels of arginine during the early post reperfusion period. This was suggested to be due to arginine influx in to the hepatocytes causing the decline in the extracellular space, and the influx was thought to be to contribute to the increased activity of the urea cycle to detoxify ammonia and also to produce vasoactive compound nitric oxide (Silva, M.A., Richards, D.A., Bramhall, S.R., Adams, D.H., Mirza, D.F., & Murphy, N. 2005). The changes in the arginine and urea cycle changes were further documented using the same study protocol of microdialysis, and increased level of arginase-I corresponded with the low extracellular arginine supports the theory of immediate urea production upon reperfusion of the liver allografts (Silva, M.A., Murphy, N., Richards, D.A., Wigmore, S.J., Bramhall, S.R., Buckels, J.A., Adams, D.H., & Mirza, D.F. 2006b).

2.4.2 Microdialysis catheter

The microdialysis catheter (figure 2-2) is designed with two lumina, at the end of which there is a semi-permeable membrane (figure 2-3). The semi-permeable membrane has a cut off value of 20K Dalton for the size of the solutes that allows permeate across. The microdialysis fluid is pumped in to the tissue through the inner channel of the catheter which then enters the semi-permeable membrane (figure 2-4). Here the microdialysis fluid is in contact with the tissue fluid of an organ separated only by the membrane, thus allowing the solutes to pass through the pores. The semi-permeable membrane is a delicate portion of the catheter therefore insertion and embedment of this in the tissue space requires special introducer.



Figure 2-2: The microdialysis catheter with its components

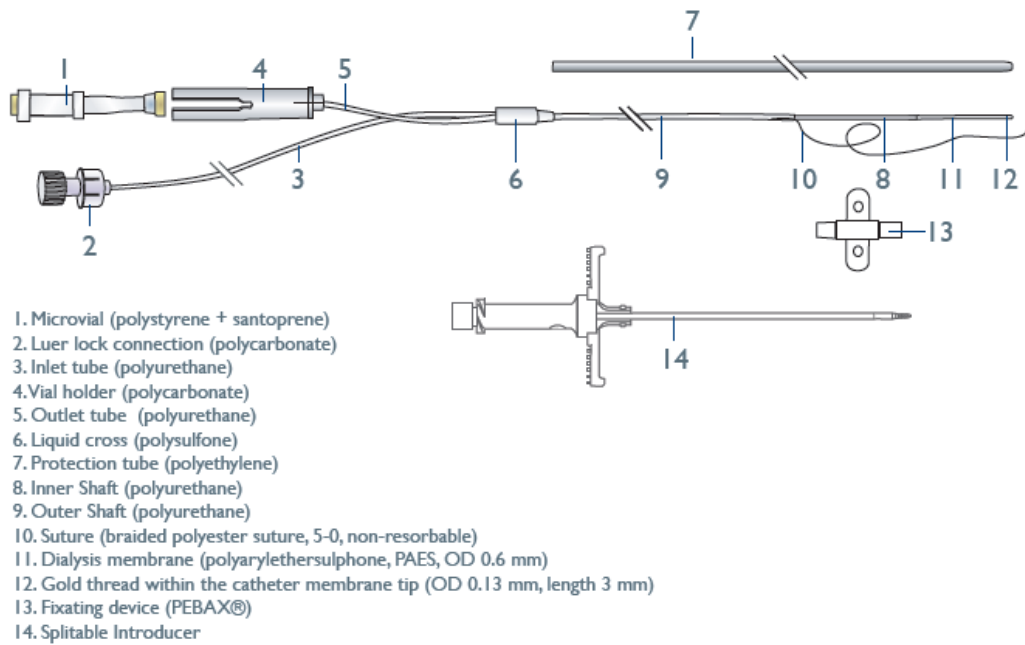

Figure 2-3: the components of a microdialysis catheter (reproduced from CMA microdialysis)

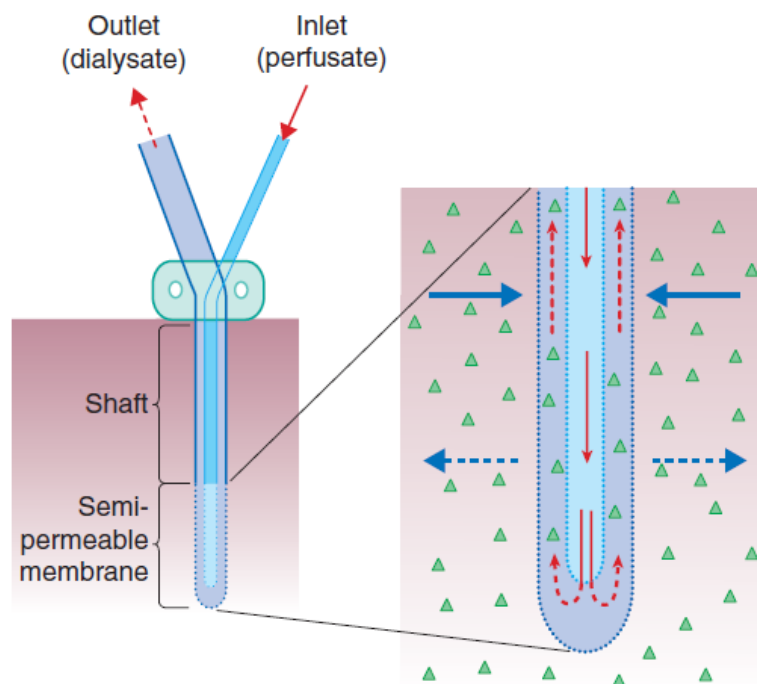

Figure 2-4: Schematic representation of the sampling end of the microdialysis catheter; the perfusate enter the sampling end through the inner core which equilibrates with the solutes within the interstitial space as it runs through the outer tube (Perera BJS 2014)

2.4.3 Microdialysis Fluid

Microdialysis fluid is (CMA Microdialysis, Stockholm, Sweden) specially prepared for the purpose, however this has an essential electrolyte composition similar to extra cellular fluid or 0.9% physiological saline (normal saline). The electrolyte composition consists of Sodium 147 mmol/l, Potassium 4.0 mmol/l, Calcium 2.3 mmol/l and Chloride 156 mmol/l in sterile fluid and supplied with 10ml ampoules. The electrolyte composition is thus similar to the extra cellular milieu hence there is no major shift of these when the microdialysis fluid is at the end of the catheter whilst in contact with tissue fluid, hence other solutes that are more abundant in the tissue space are like to enter microdialysis catheter.

2.4.4 Microdialysis pump

Microdialysis pump is a small device with approximate dimensions of 7x4x1cm and powered by two 1.2Mv lithium batteries. Both the pump and specially designed syringe are supplied by the manufacturer (CMA Microdialysis, Stockholm, Sweden) and there are various designs that are made for purpose. For research purposes of the liver there are two types of pumps; CMA 60 and CMA 61 hepatic microdialysis pumps. The differences between these two pumps are subtle and primarily related to the flow rate. The flow rate of each these pump could be adjusted by from 0.1 μ l to 0.6 μ l per minute. At slower rates, the microdialysis fluid transit across the semi-permeable membrane is slower, and the solute transit is supposed to be maximum. The syringe compartment of the pump accommodates a specially designed syringe with a capacity of up to 3.5cc of fluid. The luer lock of the syringe end is designed to connect to one end of the microdialysis pump.

2.5 Technique of Microdialysis

Microdialysis technique is a delicate procedure however simple to carry out once familiarised with the equipment and the insertion technique. The instrumentation is usually designed for the different tissues that could be studied and generally supplied as pre-assembled kits in most occasions.

2.5.1 Microdialysis kit

The microdialysis kit is an assortment of essential components provided as pre-packed sterile kit for single use only. It consists of a single microdialysis catheter, a splittable introducer and microvials and syringe from the pump. Microdialysis fluid is supplied as a separate item, and apart from the catheter all other accessories are also available as separate items.

2.5.2 Procedure

Insertion of microdialysis catheter in to the tissue space is an invasive procedure and carries a risk of inoculation or introduction of organisms, hence carries an infection risk. Therefore the procedure is carried out under sterile conditions with the

researcher fully scrubbed as for any other operative procedure. Placement of the catheter in a particular organ is determined by the anatomy of the organ concerned aiming to avoid unwanted injury to the organ. In case of the liver previous studies have suggested insertion of the catheter in to the segment IV of the liver is safer technique. The catheter introducer is inserted through the anterior surface of the liver, at a chosen site along the falciform ligament of the liver and the needle is directed towards the segment IV of the liver. The introducer is passed in to the liver parenchyma until the hilt, and the inner needle is then withdrawn leaving the plastic splittable sheath in situ. The semi-permeable end of the microdialysis catheter is then passed through the plastic sheath of the introducer in to the liver parenchyma. The two arms of the splittable sheath are then gently pulled apart to split the sheath and withdrawn whilst applying upward and outward force (figure 2-5). The chances of microdialysis catheter dislodgement are common unless care is taken, and generally an assistant holds the catheter in place prevents such misplacement. There are buttresses supplied to secure the catheter in place and the adjacent falciform ligament is used to achieve this (figure 2-6).

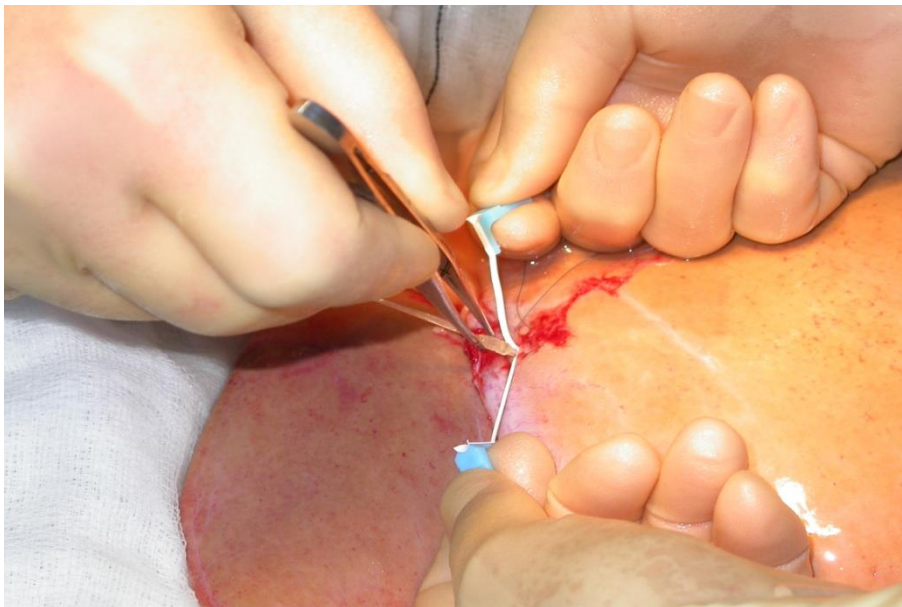

Figure 2-5: Insertion of microdialysis catheter in to the liver graft during bench phase sampling; the catheter is held in place with a pair of forceps while the splittable introducer (light blue handles) is gently withdrawn

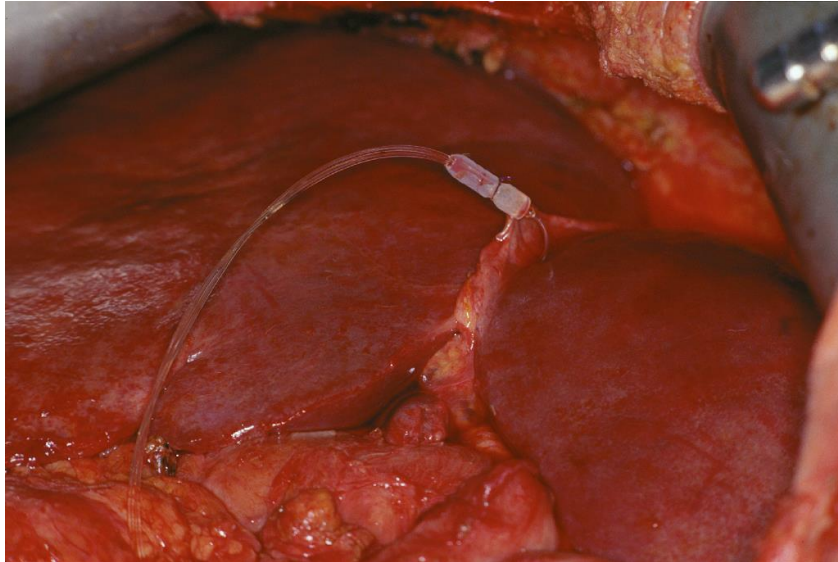

Figure 2-6: Microdialysis catheter in-situ in a transplant recipient; the catheter has been introduced at the level of falciform ligament directed towards the segment IV of the liver graft; a superficial suture used to secure the microdialysis catheter to the falciform ligament

2.6 Sampling protocols

2.6.1.1 Liver biopsies

Liver biopsies were obtained from the allografts used in liver transplantation at two stages during the process of liver transplantation. A specially designed biopsy needle used for liver biopsy [Menghini liver biopsy needle; Dixons Surgical Instruments, Wickford, United Kingdom] was a single use sterile needle with core diameter of 1.0mm with the maximum core length of 70mm (figure 2-7). Fixed to a 5cc disposable syringe partially filled with 0.9% NaCl solution, the needle is inserted to the liver graft whilst applying the suction force on the plunger of the syringe as the needle is advanced to the liver parenchyma.



Figure 2-7: The Menghini biopsy needle used for allograft biopsy sampling during the cold storage and post reperfusion; needle supplied with blocking pin that prevent suction of biopsy material to the syringe, trocar and obturator (from Dixon surgical Instruments, UK)

2.6.1.2 Microdialysate

A microdialysis catheter was inserted to the liver grafts at in the cold phase, when the liver grafts arrived at the transplanting centers and taken out of the transport box for preparation to implantation. This preparation phase is often termed “bench procedure” or operation, and the aim of this which is performed under sterile condition is to clean the liver from surrounding soft tissue including the part of the diaphragm which is taken along with the graft at the time of organ procurement. Also the hepatic artery and the portal vein are dissected free of any soft tissue so that the graft would be ready for implantation by connecting the blood supply. Generally the bench operation takes up about one hour in most cases but the duration of this part of the operation is operator dependent. The entire operation is performed whist the graft is immersed in an ice bath to maintain the cold ischaemia and to prevent the

rewarming of the graft. In transplant practice, the beginning of the bench operation often simultaneous with the admission of the transplant recipient to the anaesthetic induction, and this allows the operating surgeon to visually inspect the liver and make a decision on the usability of the graft.

A microdialysis catheter was inserted at the beginning of the bench operation and connected to the microdialysis pump for sample collection. Depending on the time of organ procurement and the planned theatre time for implantation of the graft, a variable period of cold ischaemia had been elapsed before the insertion of microdialysis catheter and this was recorded. The sample collection was continued as long as the graft remained in the ice bath at the end of the bench operation and up until the graft was taken out of ice for implantation. Therefore the sample collected represented the latter part of the cold phase of the liver graft preserved in ice, and depending on the circumstances this ranged from nearly an hour to few hours the most. Once the graft was ready to be taken out of ice bath for implantation, the microdialysis catheter was removed along with the sample vial. The sample was labeled using a labeling system to represent the patient identifier and cold phase.

The implantation phase of the liver graft is usually characterized by two distinctive phases and the surgical technique is described earlier in this chapter. The “reperfusion phase” is when the portal vein clamp is released to reperfuse the graft; the time of reperfusion is usually the portal clamp release time. This was noted in each case. The arterialisation of the graft begins after this phase followed by the biliary anastomosis or reconstruction. The surgeon ensures haemostasis is achieved surgically and coagulation correction is supported by the anaesthetist. Once the patients achieved stable haemodynamic parameters and when the abdomen is ready to be closed, a fresh microdialysis catheter was inserted into the implanted liver graft. This catheter was passed out of the abdomen at the upper end of the abdominal wound and carefully secured during the abdominal wall closure. The microdialysis pump and the vials were connected to this circuit and samples were collected at every six hours from the time of reperfusion. Because the microdialysis catheter was not introduced at the time of reperfusion of the graft which was impractical in a highly demanding clinical situation, and this was done only before the abdominal

closure, a variable time was lost in each case in the first six hour block after the reperfusion but this never went beyond six hours. Samples were then collected at each six hour block until 48 hours after the reperfusion and labeled using the same method. All microdialysate samples were then stored at -80°C.

2.7 Metabolomics

Metabolomics refers to the “study of the metabolome” and is a relatively new area of research in the biological systems. Small (<1,000 Da) catabolic and anabolic products (metabolites) can regulate, amongst other processes, cell signalling, cell-to-cell communication and energy transfer, and can be the first bio chemicals to respond to internal or external stimuli. This responsiveness makes the metabolome an informative measure of the cell’s dynamic state, a property that has led to a considerable and growing interest in the application of metabolomics in the health sciences. Recently metabolomics has begun to be used in clinical solid organ transplantation (Bohra et al. 2013;Wishart 2005a) where it holds considerable promise for the discovery of biomarkers to predict poor graft function or patient survival, as well as to elucidate the molecular mechanisms underlying pathophysiological processes such as during graft dysfunction, injury or rejection. Metabolomic studies have become a reality due to the advancement in the technological methods in detecting and analysis of smaller molecules way of high throughput studies. Overall, studies of the systems biology could be of various types depending on the target molecules of study and form a hierarchy from the nucleic acids to the metabolic products; for example genomics refer to the study of the genes, and the study transcription factors of the genes is referred as transcriptomics. Proteomics and metabolomics refer to the study of protein proteins and metabolic end products of such proteins respectively. Metabolomics is the study of the smallest molecules present in the biological systems (figure 2-8). Meanwhile, genomic studies represent the capabilities within a biological system to perform various functions which may or not all occur at any given time. For example certain biological mechanisms may remain dormant until a particular stimulus causes the gene

transcription and production of enzymes etc. Whereas further downstream the metabolomics studies may represent what is exactly happening within the biological system, and these metabolites may be active metabolic products or by products or even metabolic waste products generated in activated pathways. Therefore metabolomics could be representation of phenotype of a biological system and provides biological knowledge. Whilst genetics represent the origin of the metabolites, various other effectors may play role in changing the composition of metabolome and these include the disease status (for example, infections), environment and even the lifestyle.

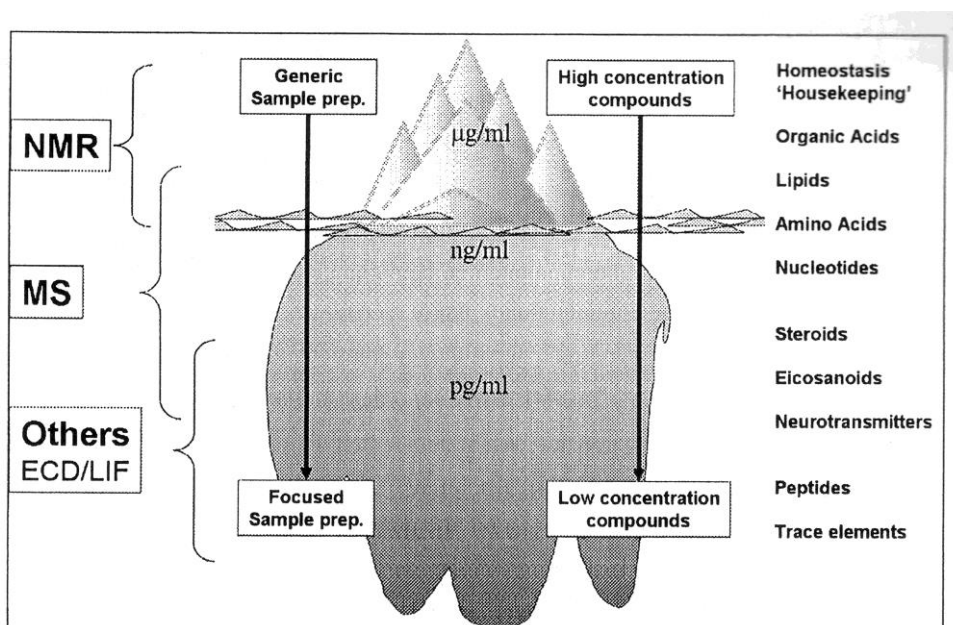

Figure 2-8: study of metabolomics and different approaches; the diagram illustrates that that the entire metabolome cannot be studied by one analytical platform alone and combination of techniques may be used to detect metabolites according to the particle size present [adapted from Van der Greef et al. "The role of metabolomics in systems Biology", In: Metabolic Profiling, Kluwer (2003)]

Metabolomic studies thus investigate very small molecules, present either in bio-tissues or fluids. There are many aspects to metabolomic studies, and these include "profiling" studies where the objective is to understand specific metabolic patterns

rather than investigation of specific pathways, which is usually done by “shotgun” approaches. Shotgun approach allows the thorough investigation of specific pathways identified through the profiling studies. A further subset study could be performed in metabolomics, for example the investigation of the lipids (lipidomics). Metabolomic studies use the long history of biochemistry in to the use, and looks at “higher order” information to look at genes and proteins, therefore the closest link to the genes and metabolic pathways. However, these studies are time consuming, and need specific instrumentation. Usually metabolomic studies generate millions of data and analysis of these data requires sophisticated statistical methods and often interpretation of these data requires the support of bioinformatics.

Several types of metabolomics studies are possible and these are facilitated by various bio-analytical tools. These include mass spectrometry (MS), Nuclear magnetic resonance (NMR), Infrared spectroscopy, and electrochemical array detection. In addition the techniques are usually combined as complementary techniques, for example liquid chromatography (LC) or gas chromatography (GC) combined with mass spectrometry (LC-MS and GC-MS respectively). Whilst the employment of a single technique is helpful in profiling techniques, combination of different techniques to investigate a particular biological system could be more advantageous in identifying specific pathways.

CHAPTER 3 PROOF OF PRINCIPLE: METABOLOMICS IN HUMAN LIVER TRANSPLANTATION

*The work outlined in this chapter was originated from the collaborative work with the School of Biosciences, University of Birmingham. Post graduate researcher Olga Hrydziuszek under the tutelage of Professor Mark Viant provided the technical support for FTICR analysis and bio-statistical input, and Dr. Doug Richards from the School of Clinical and Experimental Medicine at the University of Birmingham performed microdialysis sample analysis through CEAD. The contribution from the researcher presenting in this thesis was the microdialysis technique, sample collection, clinical data collection and correlation and interpretation of biostatistics results with clinical outcomes, and final intellectual contribution to the manuscript provided in appendix 1; **OMICS. 2010;14(2):143-50. doi: 10.1089/omi.2009.0139***

At the early phase of the proposed research plan, a smaller group of liver grafts used in liver transplantation was used to investigate the applicability of the metabolomic analytical platform described in the previous chapter. This was termed a proof of principle study, and was specifically aimed at detecting the capability of FTICR mass spectrometry and Coulometric electrochemical array detection (CEAD) as analytical platforms using the samples described previously (Hrydziuszek et al. 2010a). In this study, eight (n=8) consented adult patients undergoing orthotopic liver transplantation were recruited. The median age of recipients was 56 (46 - 62) years. The median MELD score was 20 (range 15-22).

At the end of each recipient operation, a microdialysis catheter was inserted to the liver as described earlier in chapter 2 (Silva, Richards, Bramhall, Adams, Mirza, & Murphy 2005). Bench phase microdialysis sampling was not carried out in this smaller study as longitudinal investigation of biomarker changes through cold

ischaemia to reperfusion was not aimed. Serial hourly samples were collected during the next 48 hours post reperfusion and 10 μ l of each sample were injected into the HPLC/CEAD system and chromatographic data analysis was carried out as discussed previously. Spontaneous intra-cranial bleed was the cause of brain death in all donors and the median donor age was 66 (range 40-72). In this proof of principle study, 7 out of 8 liver grafts were obtained from donors after brain death determination (DBD) whilst the remaining liver graft was from a DCD donor. The clinical outcomes following the transplantation included one case initial poor function (IPF) in the graft with AST levels of >1000 IU/L and INR >1.4 in the second day following liver transplant. Two patients died within 2 months following operation (one due to disseminated intravascular coagulation secondary to sepsis and multi organ failure, and the other due to unexplained cardiac arrest on day 5).

3.1 Liver biopsy and FT-ICR MS metabolomics

Liver tissue samples were obtained by Menghini biopsy were available for seven liver allografts at two stages during transplant process: T₁ was obtained during the cold phase bench preparation of the liver graft whilst the organ is maintained at 4°C, and T₂ at the end of transplantation surgery before abdominal closure (warm ischemia and reperfusion injury), resulting in a total of 14 samples. Liver biopsies were extracted using a methanol:chloroform:water method (Taylor et al. 2009) and the polar metabolites analysed by direct infusion nanoelectrospray FT-ICR mass spectrometry (selected ion monitoring (SIM) spectral stitching); m/z 70 to 500; positive and negative ion modes, with each sample analyzed in duplicate) (Southam et al. 2007). Spectra were processed as described previously including a 3-step filtering algorithm (Payne et al. 2009) that excluded from the peak list all of the known drugs administered to the donors and/or recipients.

3.2 Extracellular fluid and CEAD metabolomics

At the end of the recipient operation, a microdialysis catheter was inserted into the liver as described earlier in chapter 2 (Silva, Richards, Bramhall, Adams, Mirza, & Murphy 2005). The Bench phase microdialysis sampling was carried out in this smaller study as longitudinal investigation of metabolic changes through cold ischaemia to reperfusion was not aimed. Serial hourly dialysate samples were collected during the next 48 hours and 10 μ l of each sample were injected into the HPLC/CEAD system and chromatographic data analysis was carried out as discussed previously. Table 3-1 demonstrates some selected demographics along with the time sequence including the cold and warm ischaemia times and graft outcomes.

Table 3-1: Demographics, timings of liver allograft biopsy, total cold ischaemia times and period of reperfusion established prior to the T2 biopsy, combined with intra-operative parameters and outcomes of the graft recipients in the study

Patient	Age	Sex	Indications for OLT	1 st biopsy [min] after placing graft on ice (T ₁)	2 nd biopsy [min] after placing graft on ice (T ₂)	Cold ischemia time [min]	Implantation time [min]	Time of blood circulation prior to T ₂ [min]	Patient status after 2 months following OLT
H1	58	M	A1AT	110	580	450	40	168	alive
H2	59	M	PSC	100	724	600	34	76	alive
H3	54	M	Hep C+HCC	110	387	250	47	86	deceased
H4	62	M	NASH+HCC	120	685	560	35	83	alive
H5	61	F	PBC	115	541	410	41	83	alive
H6	51	F	Hep C+HCC	100	542	410	42	85	alive
H7	46	M	NASH	80	522	400	32	81	deceased
H8	53	M	ALD+HCC	125	607	490	27	83	alive

Abbreviations: A1AT, cryptogenic cirrhosis; PSC, primary sclerosing cholangitis; Hep C, hepatitis C cirrhosis; HCC, hepatocellular cancer; NASH, non-alcoholic steatohepatitis; PBC primary biliary cirrhosis; ALD, alcoholic liver disease

3.3 Histology

Half of each liver biopsy taken at each phase was preserved in 10% formaldehyde and was subjected to histological examination. Samples had a wide range of micro and macro steatosis (from mild to severe) both in T₁ and T₂ (Table 3-2). Apart from two liver grafts all other grafts had minimal macrovesicular and microvesicular steatosis.

Table 3-2: Histological grading of graft steatosis (microvesicular and macrovesicular) of the grafts used in the proof-of-principle study. Macro and micro-vesicular steatosis is expressed as a percentage during cold phase and post reperfusion biopsy samples and an increase in microvesicular steatosis is noted in post reperfusion samples whereas macro-vesicular steatosis remains somewhat unchanged

Patient	Cold phase		Post reperfusion	
	micro [%]	macro [%]	micro [%]	macro [%]
H1	<5	<5	25	<5
H2	10-15	<5	50-60	<5
H3	20	25-30	50	25
H4	50	5	70	10
H5	10-15	5	20-25	5
H6	30	0	60	<5
H7	35	<5	40	<5
H8	35	70	50-60	25

3.4 Results

3.4.1 Liver metabolism of cold phase vs. post reperfusion

The FTICR mass spectra of liver biopsies contained 1772 and 2437 reproducibly detected peaks for positive and negative ion modes, respectively. Of this total of 4209 peaks detected, 1349 were putatively identified based upon accurate mass measurements and the Kyoto Encyclopaedia of Genes and Genomes (KEGG) database (Kanehisa and Goto 2000; Taylor, Weber, Southam, Payne, Hrydziuszko, Arvanitis, & Viant 2009). Principle component analysis revealed clear separation of the biopsies from the cold phase (T_1) and post reperfusion (T_2), along PC1 for all but one patient (H7) (figure 3-1); this pattern was equally evident in both the positive and negative ion mode datasets, hence verifying the observation. This finding suggests reduced metabolic activity in the liver grafts in the non-perfused, or cold storage, whilst the higher number of peaks in the post reperfusion phase suggests return to metabolic activity in the perfused state where the organs were restored with blood supply.

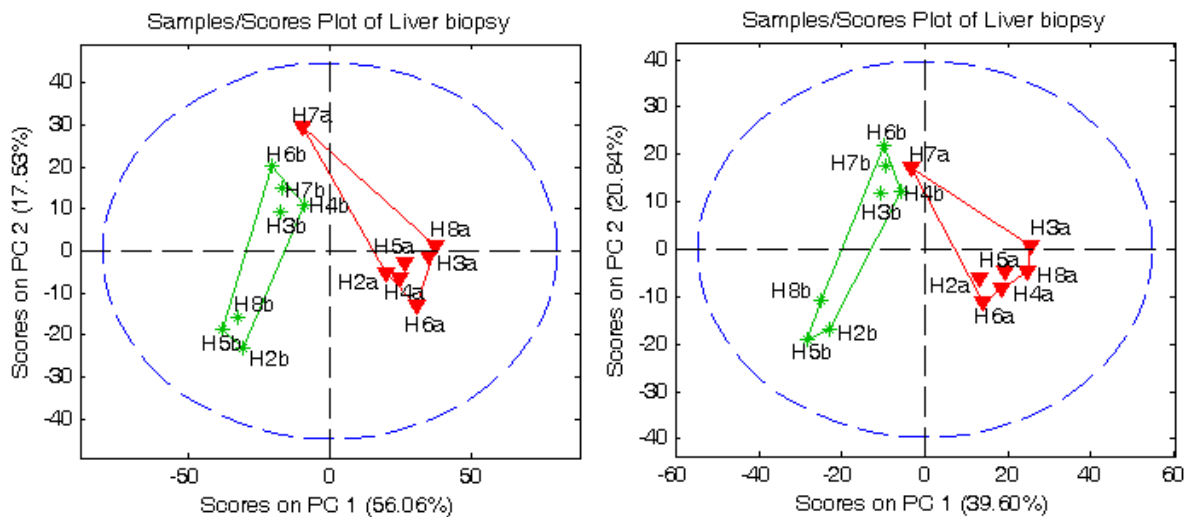

Figure 3-1: Principle analysis scores plot for liver biopsy spectra in the positive and negative ion mode; cold phase (green) and post reperfusion (red) showing an expected separation between spectra from liver biopsies in each phase is shown but within each phase close clustering could be

seen

The only outlier in the above principle component analysis is the liver graft labeled H7 in the figure 3-1. Both in the negative and positive ion mode, this allograft biopsy from the post reperfusion phase (T₂) appear to align with the cold phase biopsies. This finding may suggest that this particular liver graft did not behave like the other reperfused grafts even after restoration of blood supply within the recipient; hence the functional capacity of the graft is questionable. This recipient suffered an unexplained cardiac event 5 days post transplant and the contribution of this metabolic state of the liver graft to the eventual clinical outcome could be explained in this smaller study cohort, meanwhile it is equally difficult to refute any association between these two findings.

The univariate analysis identified 4.6% and 19.8% of all the positive and negative ion mode peaks significantly changing between T₁ and T₂. Based on the putative metabolite assignments, the biggest metabolic changes upon reperfusion (in top 1% of PC1 loadings, with smallest p values and/or largest fold changes) comprised of an increase of urea production and urea cycle intermediates levels (e.g. N4-acetylaminobutanal, 5'-Methylthioadenosine), increased bile acid levels (e.g. chenodeoxyglycocholate, glycodeoxycholate, glycochenodeoxycholate and glycholate) (table 3-3).

Furthermore, the PCA scores plot revealed that liver biopsies collected during the cold phase (T₁) were metabolically more similar to each other (tightly clustered) than post reperfusion (except H7, which was identified as an outlier in the cold phase, T₁). In the post reperfusion phase T₂, liver biopsies showed greater metabolic variability, and tended to separate into two groups (along PC2; Figure 3-1). The major contributors to this partial separation within the post reperfusion biopsies were, amongst others, putatively identified as L-valine, L-glutamate, L-glutamine, adenosine monophosphate (AMP), guanosine monophosphate (GMP), urea, and L-

histidine, all detected with multiple adducts or with a unique putative metabolite assignment.

Table 3-3: Putatively identified metabolites for peaks within 1% top PC1 loadings in FTICR analysis, smallest p values largest (up and down) fold changes

Reason for inclusion	Rank	m/z	Fold change	Empirical Formula	Metabolite	Adduct
Large increase	2	472.30359	24.10	C26H43NO5	Chenodeoxyglycocholate, Glycodeoxycholate, Glycochenodeoxycholate	Na
Large increase	4	461.04088	17.49	C14H20N6O5S	S-Adenosyl-L-homocysteine	2*K(39)-
Large increase	6	488.29844	14.47	C26H43NO6	Glycocholate	Na
Large increase	7	472.00083	14.02	C10H15N5O10P2	ADP (3)	2*Na-H
Large increase	13	338.05072	10.81	C11H15N5O3S	5'-Methylthioadenosine (2)	K(41)
Large increase	14	197.02222	12.07	C7H12O4	6-Carboxyhexanoate (3)	K(39)-
Large increase	15	488.27758	9.81	C26H43NO5	Chenodeoxyglycocholate,	K(39)
Large increase	16	80.94784	9.80	HCl	HCl	2*Na-H
Large increase	18	424.22	9.15	C18H38NO5P	Sphingosine 1-phosphate	2*Na-H
Large increase	20	192.02433	8.26	C5H9NO4	L-Glutamate (5)	2*Na-H
Large increase	14	197.02222	12.07	C7H12O4	6-Carboxyhexanoate (3)	K(39)-
Large decrease	25	223.04031	0.06	C6H14O6	Mannitol (3)	K(41)
Large decrease	30	221.04218	0.06	C9H10O5	Mannitol (5)	Na
t test	4	130.08627	2.76	C6H11NO2	N4-Acetylaminobutanal (3)	H
t test	9	83.02158	2.87	CH4N2O	Urea	Na
t test	10	164.00832	3.12	C2H8NO4P	Ethanolamine phosphate;	Na
t test	12	175.04782	2.77	C7H8N2O2	N1-Methyl-2-pyridone-5-	Na
t test	18	178.05874	3.72	C6H9N3O2	L-Histidine	Na
t test	8	182.02257	4.43	C5H9NO4	L-Glutamate (8)	Cl(35)
t test	9	184.01963	2.55	C5H9NO4	L-Glutamate (5)	Cl(37)
PC 1	8	221.04218	0.06	C6H14O6	Mannitol (5)	K(39)
PC 1	10	223.04031	0.06	C6H14O6	Mannitol (3)	K(41)
PC 1	17	472.30359	24.10	C26H43NO5	Chenodeoxyglycocholate, Glycodeoxycholate,	Na
PC 1	5	315.0932	0.04	C14H18N2O4	alpha-Ribazole	Cl(37)
PC 1	17	191.01974	0.05	C4H4O5	Oxaloacetate (5)	HAc-H

Note: numbers in parentheses show the number of all possible putative metabolite identities, large increase and decrease is when observed in post reperfusion samples relative to the cold phase samples.

3.4.1.1 Relating molecular phenotype to clinical outcome – preliminary findings

Peaks detected in the early post reperfusion phase (T_2) that could predict successful vs. unsuccessful patient outcome were identified using KNN algorithm. The two unsuccessful grafts were characterized by elevated levels of L-glutamate, homoarginine, glycerophosphocholine (GPC), 1-ribosylimidazole-4-acetate (histidine metabolism) and O-succinyl-L-homoserine (methionine and sulfur metabolism), 7,8-Dihydro-7,8-dihydroxykynurenate, 4-(2-Amino-3-hydroxyphenyl)-2,4-dioxobutanoate and 4-(2-Amino-5-hydroxyphenyl)-2,4-dioxobutanoate (tryptophan metabolism) all detected with multiple adducts or with only one putative metabolite assignment (Table 3-4). Tryptophan metabolism appeared to be altered – peak was assigned multiple putative metabolites and latter three identified metabolites were participating in tryptophan metabolism. Successful grafts were characterized by altered (increased metabolite levels) pentose phosphate pathway and pentose-glucuronate interconversion (e.g. D-ribose) and pyrimidine metabolism (e.g. uridine), and the conversely the lack of above conversions was a remarkable finding in those grafts with an unsuccessful outcome.

Table 3-4: Peaks identified in the KNN algorithm (successful vs. unsuccessful grafts) with putative metabolite assignments and corresponding KEGG pathways;
fold change calculated as mean of successful peak divided by mean of unsuccessful field level

No	Peak	m/z	Fold change	Empirical Formula	Metabolite	Adduct	KEGG pathways
3	81	148.0605	0.48	C5H9NO4	L-Glutamate;	H	ko00220 Urea cycle and metabolism of amino groups, ko00251 Glutamate metabolism, ko00330 Arginine and proline metabolism, ko00340 Histidine metabolism, ko00471 D-Glutamine and D-glutamate metabolism, ko00480 Glutathione metabolism, ko00650 Butanoate metabolism, ko00860 Porphyrin and chlorophyll metabolism, ko00910 Nitrogen metabolism, ko00970 Aminoacyl-tRNA biosynthesis, ko02010 ABC transporters, ko04080 Neuroactive ligand-receptor interaction, ko04540 Gap junction, ko04720 Long-term potentiation, ko04730 Long-term depression, ko04742 Taste transduction, ko05014 Amyotrophic lateral sclerosis (ALS)
3	81	148.0605	0.48	C5H9NO4	D-Glutamate;	H	ko00251 Glutamate metabolism, ko00471 D-Glutamine and D-glutamate metabolism, ko00750 Vitamin B6 metabolism
3	81	148.0605	0.48	C5H9NO4	Glutamate;	H	ko00460 Cyanoamino acid metabolism
3	81	148.0605	0.48	C5H6O4	2,5-Dioxopentanoate;	NH4+	ko00053 Ascorbate and aldarate metabolism, ko00330 Arginine and proline metabolism
3	81	148.0605	0.48	C5H9NO4	O-Acetyl-L-serine;	H	ko00272 Cysteine metabolism, ko00450 Selenoamino acid metabolism, ko00920 Sulfur metabolism
3	81	148.0605	0.48	C5H6O4	(E)-Glutaconate;	NH4+	
3	81	148.0605	0.48	C5H6O4	2-Methylmaleate;	NH4+	ko00290 Valine, leucine and isoleucine biosynthesis
3	81	148.0605	0.48	C5H6O4	4,5-Dioxopentanoate;	NH4+	ko00860 Porphyrin and chlorophyll metabolism
3	81	148.0605	0.48	C5H9NO4	L-4-Hydroxyglutamate semialdehyde	H	ko00330 Arginine and proline metabolism
3	81	148.0605	0.48	C5H9NO4	2-Oxo-4-hydroxy-5-aminovalerate	H	ko00330 Arginine and proline metabolism
3	81	148.0605	0.48	C5H9NO4	N-Methyl-D-aspartic acid;	H	

5	182	173.042	2.36	C5H10O5	D-Ribose	Na	ko00030 Pentose phosphate pathway, ko02010 ABC transporters, NA
5	182	173.042	2.36	C5H10O5	D-Xylose;	Na	ko00040 Pentose and glucuronate interconversions, ko00500 Starch and sucrose metabolism, ko00520 Nucleotide sugars metabolism, ko02010 ABC transporters
5	182	173.042	2.36	C5H10O5	L-Arabinose;	Na	ko00040 Pentose and glucuronate interconversions,
5	182	173.042	2.36	C5H10O5	D-Ribulose;	Na	ko00040 Pentose and glucuronate interconversions
5	182	173.042	2.36	C5H10O5	D-Xylulose;	Na	ko00040 Pentose and glucuronate interconversions
5	182	173.042	2.36	C5H10O5	L-Xylulose;	Na	ko00040 Pentose and glucuronate interconversions
5	182	173.042	2.36	C5H10O5	D-Lyxose	Na	ko00040 Pentose and glucuronate interconversions
5	182	173.042	2.36	C5H10O5	L-Ribulose;	Na	ko00040 Pentose and glucuronate interconversions
5	182	173.042	2.36	C5H10O5	L-Lyxose	Na	ko00040 Pentose and glucuronate interconversions
5	182	173.042	2.36	C5H10O5	beta-D-Ribopyranose;	Na	
8	278	189.1346	0.31	C7H16N4O2	Homoarginine	H	
9	295	191.1026	0.81	C7H14N2O4	LL-2,6-Diaminoheptanedioate;	H	ko00300 Lysine biosynthesis
9	295	191.1026	0.81	C7H14N2O4	meso-2,6-Diaminoheptanedioate;	H	ko00300 Lysine biosynthesis
9	295	191.1026	0.81	C7H11NO4	N-Acetyl-L-glutamate 5-semialdehyde;	NH4+	ko00220 Urea cycle and metabolism of amino groups
11	376	216.0632	0.32	C10H11NO3	Phenylacetyl glycine	Na	ko00360 Phenylalanine metabolism
11	376	216.0632	0.32	C10H11NO3	3-Carbamoyl-2-phenylpropionaldehyde	Na	ko00982 Drug metabolism - cytochrome P450
11	376	216.0632	0.32	C10H11NO3	4-Hydroxy-5-phenyltetrahydro-1,3-oxazin-2-one	Na	ko00982 Drug metabolism - cytochrome P450
11	376	216.0632	0.32	C5H14NO6P	sn-glycero-3-Phosphoethanolamine;	H	ko00564 Glycerophospholipid metabolism, ko00565 Ether lipid metabolism
13	575	258.1101	0.3	C8H21NO6P	sn-glycero-3-Phosphocholine;	'e'	ko00564 Glycerophospholipid metabolism, ko00565 Ether lipid metabolism
16	622	267.0587	1.95	C9H12N2O6	Uridine	Na	ko00240 Pyrimidine metabolism
16	622	267.0587	1.95	C9H12N2O6	Pseudouridine	Na	ko00240 Pyrimidine metabolism
17	625	268.0192	0.52	C10H9NO5	7,8-Dihydro-7,8-dihydroxykynurenate	2*Na-H	ko00380 Tryptophan metabolism
17	625	268.0192	0.52	C10H9NO5	4-(2-Amino-3-hydroxyphenyl)-2,4-	2*Na-H	ko00380 Tryptophan metabolism
17	625	268.0192	0.52	C10H9NO5	4-(2-Amino-5-hydroxyphenyl)-2,4-	2*Na-H	ko00380 Tryptophan metabolism
18	651	276.1191	0.36	C10H14N2O6	(1-Ribosylimidazole)-4-acetate	NH4+	ko00340 Histidine metabolism
30	1048	363.1163	0.22	C12H24N2O8	Procollagen 5-(D-galactosyloxy)-L-lysine	K(39)	
2	38	140.01183	0.72	C2H8NO4P	Ethanolamine phosphate;	'-H'	ko00260 Glycine, serine and threonine metabolism, ko00564 Glycerophospholipid metabolism, ko00600 Sphingolipid metabolism
2	38	140.01183	0.72	C2H8NO4P	1-Hydroxy-2-aminoethylphosphonate	'-H'	ko00440 Aminophosphonate metabolism

4	97	168.02787	0.63	C5H9NO4	L-Glutamate;	Na-2*H	ko00220 Urea cycle and metabolism of amino groups, ko00251 Glutamate metabolism, ko00330 Arginine and proline metabolism, ko00340 Histidine metabolism, ko00471 D-Glutamine and D-glutamate metabolism, ko00480 Glutathione metabolism, ko00650 Butanoate metabolism, ko00860 Porphyrin and chlorophyll metabolism, ko00910 Nitrogen metabolism, ko00970 Aminoacyl-tRNA biosynthesis, ko02010 ABC transporters, ko04080 Neuroactive ligand-receptor interaction, ko04540 Gap junction, ko04720 Long-term potentiation, ko04730 Long-term depression, ko04742 Taste transduction, ko05014 Amyotrophic lateral sclerosis (ALS)
4	97	168.02787	0.63	C5H9NO4	D-Glutamate;	Na-2*H	ko00251 Glutamate metabolism, ko00471 D-Glutamine and D-glutamate metabolism, ko00750 Vitamin B6 metabolism
4	97	168.02787	0.63	C5H9NO4	Glutamate;	Na-2*H	ko00460 Cyanoamino acid metabolism
4	97	168.02787	0.63	C5H9NO4	O-Acetyl-L-serine;	Na-2*H	ko00272 Cysteine metabolism, ko00450 Selenoamino acid metabolism, ko00920 Sulfur metabolism
4	97	168.02787	0.63	C5H9NO4	L-4-Hydroxyglutamate semialdehyde	Na-2*H	ko00330 Arginine and proline metabolism
4	97	168.02787	0.63	C5H9NO4	2-Oxo-4-hydroxy-5-aminovalerate	Na-2*H	ko00330 Arginine and proline metabolism
4	97	168.02787	0.63	C5H9NO4	N-Methyl-D-aspartic acid;	Na-2*H	
5	107	173.0092	1.49	C6H6O6	cis-Aconitate;	'-H'	ko00020 Citrate cycle (TCA cycle), ko00630 Glyoxylate and dicarboxylate metabolism, ko00720 Reductive carboxylate cycle (CO2 fixation)
5	107	173.0092	1.49	C6H6O6	trans-Aconitate;	'-H'	
5	107	173.0092	1.49	C4H2O4	Acetylenedicarboxylate;	HAc-H	ko00620 Pyruvate metabolism
5	107	173.0092	1.49	C6H6O6	Dehydroascorbate;	'-H'	ko00053 Ascorbate and aldarate metabolism, ko00480 Glutathione metabolism
6	344	218.06704	0.51	C8H13NO6	O-Succinyl-L-homoserine	'-H'	ko00271 Methionine metabolism, ko00920 Sulfur metabolism
7	372	222.04418	0.37	C5H9NO3S	Acetylcysteine	HAc-H	
29	1245	325.0653	1.52	C11H16N2O8	N-Acetyl-aspartyl-glutamate;	Na-2*H	ko04080 Neuroactive ligand-receptor interaction

3.4.2 Redox metabolism in microdialysates post reperfusion

A total of 19 reproducible peaks were detected by CEAD in the microdialysates and subjected to PCA. Time trajectories on the scores plot were quite consistent for all patients (Figure 3-2). The first samples from the patients (5-6h post reperfusion) group together with large positive PC1 scores. Samples from subsequent time points were similarly grouped, but towards increasingly more negative PC1 scores, as highlighted by the average metabolic trajectory for all patients (Figure 3-3). This shift along the PC1 axis was greatest for samples obtained up to 21h post reperfusion, after which a period of metabolic stability ensued.

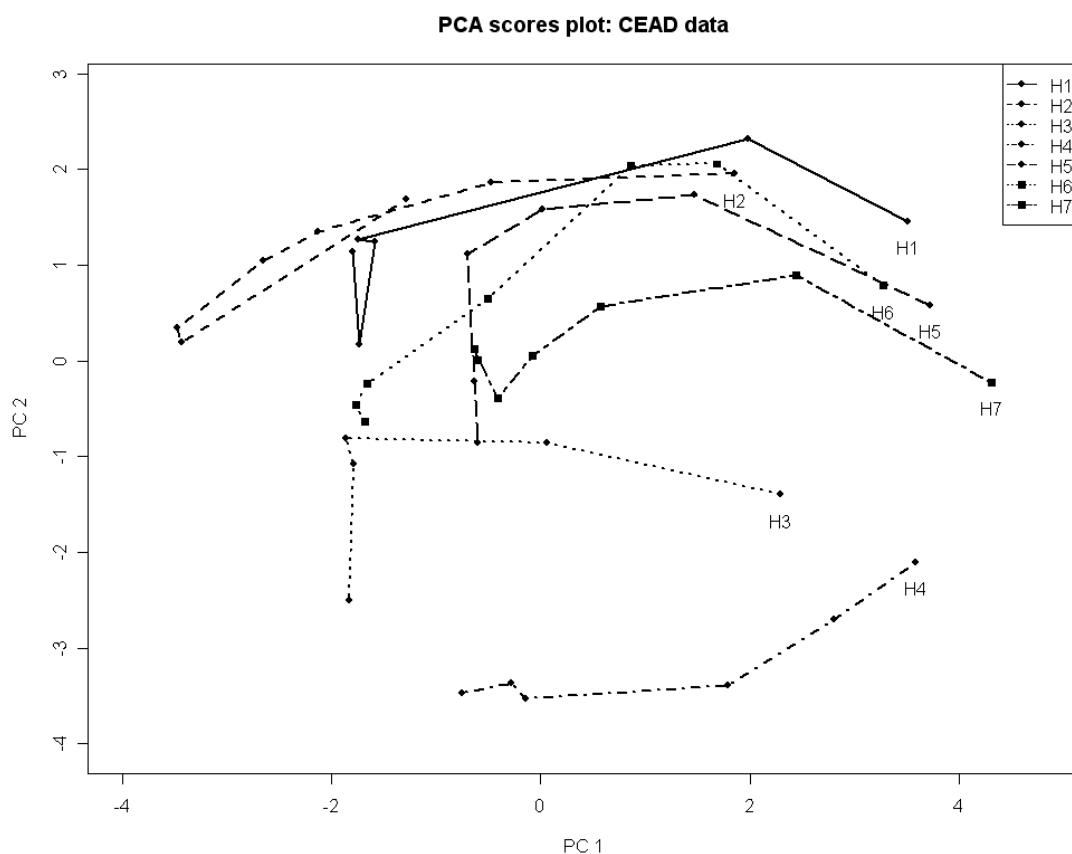

Figure 3-2: Principle score analysis plot for CEAD time course data. First time point for each patient is on the right as also indicated by the patient labels and time trajectory for the samples from each patient follows a similar trend

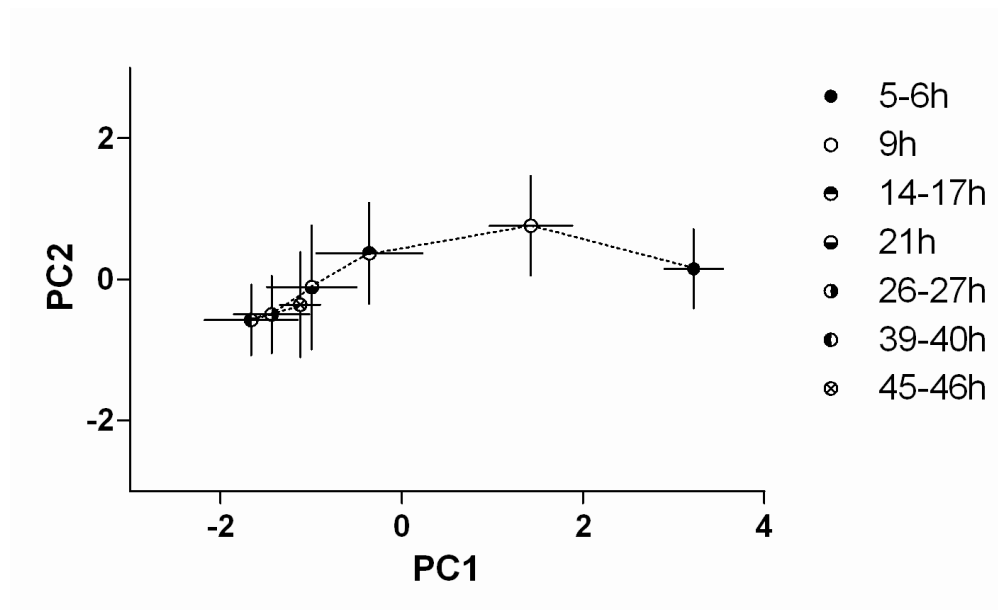

Figure 3-3: Principle scores plot for CEAD time course data (first time point for each patient is on the right, as also indicated by the patient label) showing that the metabolism following reperfusion changed rapidly to stabilize nearly 21hrs post reperfusion

3.5 Discussion

FT-ICR mass spectrometry of liver biopsy extracts allowed the rapid and reproducible detection of 4209 unique peaks, representing a wealth of metabolic information on the functional biochemical changes associated with liver transplantation. This pilot study revealed that from a holistic viewpoint, liver grafts share a remarkably alike metabolic profile in the cold phase, suggesting that metabolism is down-regulated in a similar manner. This is in itself quite remarkable given the relative heterogeneity (human-to-human natural variations and inevitable variations in liver transplant procedure) and small number of donors involved in this pilot project. Furthermore, several anticipated metabolic differences between cold phase and post reperfusion biopsies were identified, which serve to verify the FTICR mass spectrometry approach and its applicability for measuring multiple metabolic pathways simultaneously. Specifically, we documented evidence that reperfused

grafts restart their metabolic activity and physiological functions, including synthesis (e.g. bile acid production, urea synthesis) and excretion (clearance of UW solution), with the latter one also being in agreement with the previous NMR studies (Duarte et al. 2005). Again from a holistic viewpoint, liver biopsies exhibited considerably greater metabolic variability following reperfusion. This is again what would be expected considering the variation in the OLT procedure itself as well as the impact of the recipient's metabolism on the graft. Another expected biochemical response to OLT was a disturbance of energy metabolism (increase of metabolites levels involved in energy metabolism). The top 1% changes comprised only a couple of putative metabolites involved in this process (formate, L-aspartate ADP, AMP). However, additional analysis showed that there was a remarkably consistent increase of abundance of 'energy' involved metabolites (similar analysis on carbohydrate and amino acids metabolism did not show similar consistency, which emphasizes the results), especially the ones involved in oxidative phosphorylation (fumarate, orthophosphate, pyrophosphate, ADP), showing that it is possible to extract a meaningful information not only from an analysis of peaks contributing to the major changes.

Considering the second analytical approach, the combination of microdialysis sampling and CEAD time trajectory data allowed the longitudinal analysis of liver metabolism post-reperfusion. It detected a series of changes in the redox metabolism of extracellular fluid, revealing a rapidly changing liver metabolism immediately post reperfusion followed by stabilization after ca. 21 h.

The FTICR mass spectra revealed two intriguing findings, which, due to the small number of patients, must be interpreted with caution. First, the only liver graft obtained by donation after cardiac death corresponded to the only outlier on the PCA scores plot, having a metabolite profile in the cold phase more similar to the other livers' metabolic profiles in the post reperfusion (T_2) stage. This may have resulted from a less effective perfusion of the graft with preservation solution, since it was performed after a period of circulatory arrest (e.g. possibility of micro clot formation), which would have several consequences for graft metabolism. For

example, less effective preservation could result in potentially ongoing and injurious metabolic activity within the cold phase graft (T_1) that more closely resembles post reperfusion (T_2) metabolism. The second intriguing finding, revealed in both the positive and negative ion PCA scores plots, is the apparent separation of the post reperfused biopsies into two groups. The two patients with unsuccessful outcome, i.e. who died within 2 months of OLT, were clustered in one of these groups. Further investigation of these findings with a KNN analysis suggests that during the period that the second biopsy was collected in the post reperfusion phase (Table 3-1) the liver metabolism varies quite considerably between patients, perhaps due to differing rates of metabolic recovery of liver function. This is consistent with the CEAD data which highlights the considerable change in metabolism in the first 21h of reperfusion. At post reperfusion time T_2 , some metabolites (e.g. histidine) varying not having the effect on the OLT outcome, while others (e.g. urea, GPC) are potentially predictive of OLT outcome. Encouragingly, the unvarying levels of GPC throughout OLT were suggested as a potential marker of IPF in the NMR liver biopsy studies (Duarte, Stanley, Holmes, Lindon, Gil, Tang, Ferdinand, McKee, Nicholson, & Vilca-Melendez 2005). In our results, GPC was not significantly changed between T_1 and T_2 (p value 0.38). The patient who developed IPF (H8) was clustered in the other group, suggesting that perhaps there are yet different metabolic processes, involving creatinine and IMP, altered. Finally, it may be worth noticing that histological data were not consistent with the clinical data or the metabolomics studies.

Collectively, this pilot study shows that FT-ICR mass spectrometry and CEAD are useful tools for characterizing multiple metabolic pathways in the liver throughout and following liver transplantation. We have focused our interpretation and discussion on the measurements of known and expected biochemical changes during transplantation, since this serves to validate the application of these metabolomics methods. However, it is crucial to emphasize that more than 4000 signals were detected in the mass spectra and CEAD chromatograms, which could contain a wealth of novel metabolic information associated with liver transplantation including predictive markers of clinical outcome or poor graft function. However,

extracting such knowledge would require the application of more powerful supervised multivariate statistical methods, which in turn is dependent upon a considerably larger patient cohort, which were basis for the larger studies comparing DCD and DBD grafts that followed. In addition, the definitive identification of the metabolites within these metabolomics datasets would further strengthen our interpretation. This awaits the on-going development of automated metabolite identification strategies. The initial success of this pilot study, in terms of the ability of two metabolomics approaches to identify key metabolic changes within a relatively heterogeneous group of only eight donor liver grafts encouraged us proceed with the much larger study cohort comparing different graft types.

CHAPTER 4 CHANGES IN BASIC ENERGY METABOLISM AND KEY DIFFERENCES IN LIVER GRFATS FROM DCD AND DBD DONORS

*The data presented in this chapter represents researcher's own work published as an original manuscript and presented in Appendix 2; **Br J Surg. Jun;101(7):775-83. doi: 10.1002/bjs.9478.***

4.1 Introduction

Cold ischaemia results in the switching on of anaerobic metabolism in the absence of oxidative metabolism. Anaerobic metabolism is one of the primary fallback energy generating mechanism in all cell systems, and there is continuous utilization of intracellular energy resources during the process of anaerobic metabolism. In the aerobic respiratory state, primary energy substrate glucose is metabolized through the process of glycolysis yielding two molecules of pyruvate, which in turn enters the Krebs' cycle. Complete oxidization refers to the combination of glycolysis and Krebs' cycle that yield maximum number of adenosine tri-phosphate (ATP) molecules for energy depending biological processes within cells. However, in the absence of oxidative metabolism pyruvate is metabolized through the anaerobic pathway; though this pathway is energy driven, there is a net gain of two ATP molecules and this is used for basic intra-cellular mechanisms in the reduced metabolic state. Primarily this energy is used to maintain ATP driven Na⁺/K⁺ pumps which are paramount in maintaining cellular integrity.

Complete intracellular energy exhaustion is associated will cell death; however maintenance of cellular integrity is an energy dependent process. Plasma membrane bound Na⁺/K⁺ pumps are primarily responsible in maintaining the efflux of Na⁺ from

the intracellular compartment to the extracellular compartment, in exchange for K⁺ ions, and these Na⁺/K⁺ pumps are driven by ATP. In the absence of these intracellular accumulation of the Na⁺ is associated with water retention, oedema and finally rupture of the plasma membrane culminating in cell death. In tissues or organs, the degree of ischaemic tolerability is determined by many factors. Once the oxygen supply is halted, anaerobic metabolism takes over for a period of time, and generation of ATP is continued using the intracellular energy reserves, primarily glycogen stores. Glycogen stores provide the energy substrate for metabolism when there is no external supply of primary energy substrate glucose delivered in to the tissues. Therefore, ischaemic tolerability is relied on the amount of intracellular energy reserves and the anaerobic threshold of the tissue. Some organs or the tissues with body do not have intracellular energy reserves at all, for example neuronal cells in the brain, hence entirely depend on the constant supply of glucose and oxygen received from the circulation. Therefore the brain becomes extremely sensitive and even shortest periods of hypoxia leads to irreversible and permanent brain injury.

The liver on the other hand is the primary metabolic organ of the body. Hepatocytes store large amounts of energy in the form of glycogen, and even in the fasted state releases glucose in to the circulation through conversion of glycogen stores to glucose and also through gluconeogenesis (Silva, Murphy, Richards, Wigmore, Bramhall, Buckels, Adams, & Mirza 2006b). The primary difference existing between the DCD and DBD donors was discussed in Chapter 1; donor warm ischaemia originating from lower oxygen saturation of peripheral blood and hypotension are common after treatment withdrawal in a DCD donor. The cellular systems within such a donor would continue to use intracellular energy stores, through anaerobic metabolic pathways. Therefore it could be hypothesized that the DCD grafts have depleted energy reserves at the beginning of the cold ischaemia, when compared with DBD liver grafts. Meanwhile energy utilization and intracellular metabolism is continued, albeit at a slower rate through cold storage which further compound the depletion of energy stores. Therefore it could be regarded that the added warm

ischaemia prior to the beginning of cold ischaemia in the DCD donor aggravate the ischaemic insult.

Previously, our research group in Birmingham studied the changes in basic energy metabolism within DBD grafts using microdialysis. These studies focused on lactate, pyruvate, glucose and glycerol levels in selected DBD graft cohort, and shown that initial high lactate recorded within liver allografts rapidly cleared following reperfusion of the grafts. Also lower levels of pyruvate at the end of the cold storage were rapidly replenished after the reperfusion. When these two findings were combined together, a calculated Lactate/pyruvate ratio was higher in the cold storage with the reversal of this ratio following the reperfused state (Figure 4-1). Previous studies have shown that increased lactate/pyruvate ratio is a hallmark of ischaemia and the evidence is origination from virtually every human tissue. Although proven in the DBD liver transplantation setting, comparative energy reserves assessment has not been carried out with DCD liver grafts. At the outset we hypothesized that DCD liver grafts should have more combined ischaemic damage due to donor warm ischaemia and cumulative cold ischaemia. We therefore anticipated that significant difference between the basic energy metabolic markers between the DCD and DBD grafts.

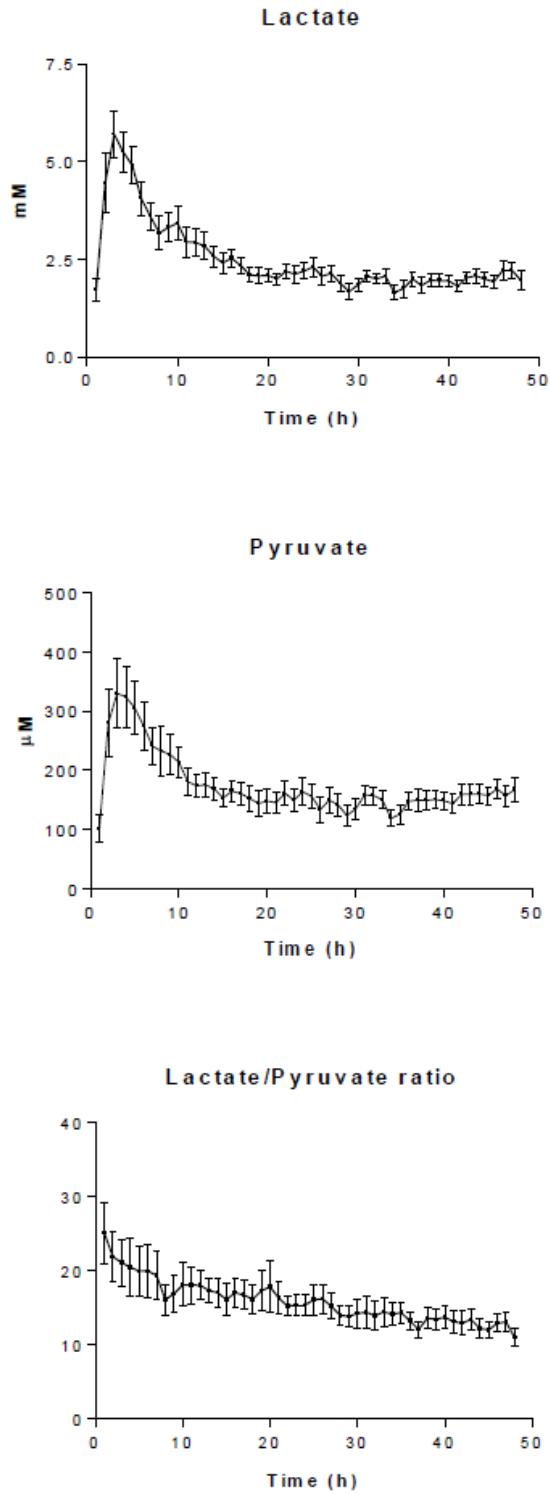

Figure 4-1: Mean (standard error of mean) of lactate, pyruvate and calculated lactate: pyruvate ratio; showing initial high levels. Lactate/pyruvate ratio was initially high in the immediate post reperfusion period and then dropped to baseline levels

4.2 Methods

4.2.1 Microdialysis analyser and colourimetry

The ISCUS Microdialysis Analyzer (CMA Microdialysis®, Stockholm, Sweden) is a third generation, clinical chemistry analyzer specifically designed to handle the extremely small microdialysis sample volumes (figure 4-2; reproduced from product note ISCUSfelx.pdf <http://www.mdialysis.com/analyzers/iscusflex-for-point-of-care>). The analyzer uses enzymatic reagents and colorimetric measurements to make chemical analyses of lactate, pyruvate and glycerol. The reagent enzymatically oxidizes the substrate, and hydrogen peroxide is formed, which is detected through its peroxidase-catalysed reaction with a chromogen. The final product of this series of reaction is the formation of red-violet end product quinoneimine or quinonediimine according to the analyte under experiment and measured photometrically at 546nm wavelength (Nowak, Ungerstedt, Wernerman, Ungerstedt, & Ericzon 2002a). The kinetics of the reaction is based on the rate of the enzymatic reaction as an increase in the absorption over 30seconds. The reaction rate depends on the concentration of the analyte. In simple terms, higher the concentration of measured analyte present in the microdialysate yields a higher absorbance curve which is returned in comparison of absorbance versus time curve obtained from a standard solution with calibrator.



Figure 4-2: The ISCUS microdialysis analyser (reproduced from product note ISCUSfelx.pdf <http://www.mdialysis.com/analyzers/iscusflex-for-point-of-care>)

Microdialysis analyser was originally designed for easy bedside monitoring of metabolic compounds and easy to operate. This kinetic enzyme analyser could be used to analyse various basic metabolites when used in conjunction with the appropriate reagent. Each sample measurement takes up to 30minutes when used in the analysis of multiple samples and assessment of different analytes within the same sample; the throughput time is 90 seconds per sample. The detector used in the analyser is a single beam filter meter and the light source is a Class 1 LED light. The detector cell holds 2 μ l of sample and maintained at 37^oC. The analyser could test up to 16 samples could be loaded in to the analyser at any given time. All reagents are supplied by the manufacture in 6ml ampoules that should be used within 5 days after opening.

4.2.1.1 Lactate

The lactate in the microdialysis fluid is first oxidised by lactate oxidase with the formation of pyruvate and hydrogen peroxide, which in turn reacts with 4-chlorophenol and 4-amino-antipyrine. This reaction is catalyzed by peroxidase (POD) and yields the red-violet coloured quinoneimine (figure 4-3). The minimal sample volume required is 0.2 μ L per measurement and the linear range that could be detected by the analyser ranges between 0.1-12 mmol/L.

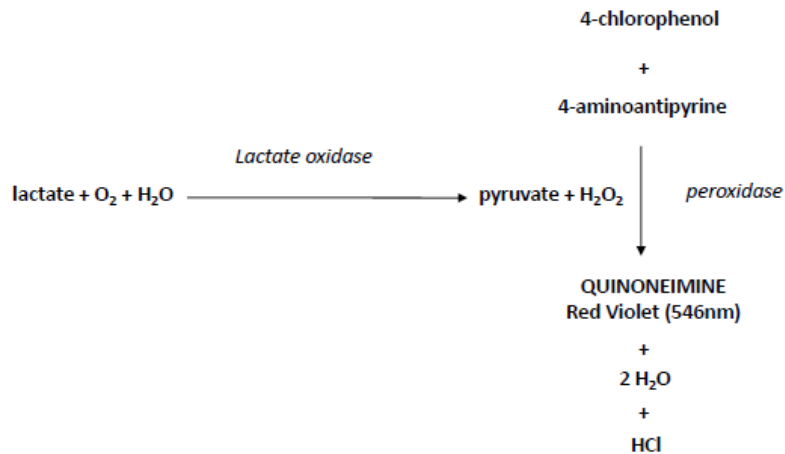

Figure 4-3: chemical reactions leading to the colorimetric detection of lactate present within sample by the microdialysate analyser

4.2.1.2 Pyruvate

The enzymatic reactions leading to the colorimetric detection of pyruvate is different to that of lactate, and pyruvate in the tested sample is enzymatically oxidized and the end product is quinonediimine instead of quinoneimine (figure 4-4). The initial reaction is oxidation of pyruvate catalysed by pyruvate oxidase with the formation of hydrogen peroxide, which then reacts with N-ethyl-N-(2-hydroxy-3-sulfopropyl)-m-toluidine and 4-amino-antipyrine. This reaction yields the red-violet coloured quinonediimine. Much higher sample volumes are required for pyruvate measurements (0.5µL).

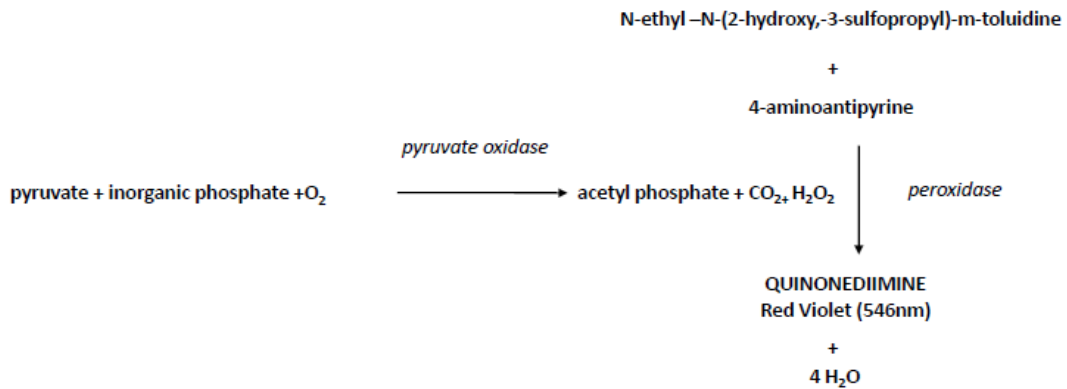

Figure 4-4: Chemical reactions leading to the detection of pyruvate concentration of a sample by the microdialysate analyser

4.2.1.3 Lactate/pyruvate ratio

Lactic acid is H⁺ ion donor and dissociated into lactate and hydrogen ion, and this causes intracellular acidosis which is a protective mechanism. As some degree of cellular damage is inevitable during the preservation these molecules are readily pass through the damaged cell membranes thus these molecules could present in the extracellular compartment. The degree of lactic acidosis corresponds with the degree of tissue ischaemia and probably directly proportionate. There is increasing evidence to suggest that lactate/pyruvate ratio is better marker of energy depletion of a tissue (Jansson et al. 2009). With more and more pyruvate being metabolized through anaerobic metabolism, catalysed by lactate dehydrogenase enzyme the intracellular pyruvate stores are depleted with prolongation of cold ischaemia time. In the absence of external glucose source, generally delivered to the cells by the blood flow in the living state, the only other source of pyruvate generation is the breakdown of intracellular energy stores, in the form of glycogen breakdown.

4.2.1.4 Glycerol

Glycerol present in the microdialysate is initially phosphorylated by adenosine triphosphate and glycerol kinase to form glycerol-3-phosphate, which is subsequently oxidized in the presence of glycerol-3-phosphate oxidase forming hydrogen peroxide. This in turn reacts with 3,5-dichloro-2-hydroxy-benzene sulphonic acid (DCHBS) and 4-amino-antipyrine which is catalyzed by peroxidase (POD). The end product of this series of chemical reactions is the formation of violet coloured quinoneimine (figure 4-5). Similar to the pyruvate measurements above, 0.5µL of sample fluid is required for each run of the analysis.

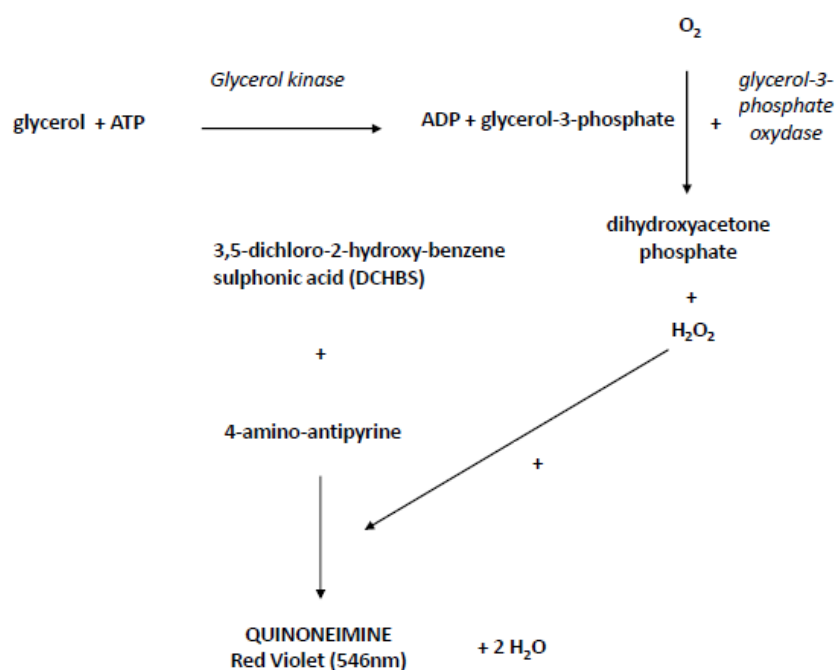

Figure 4-5: Chemical reactions leading to the detection of glycerol concentration of sample by the microdialysate analyser

Overall, the measurement of lactate, pyruvate and glycerol concentrations in each microdialysis sample consumes up to 12µL of microdialysis fluid. Whilst these are direct measurements, the lactate/pyruvate ratio was calculated using the above

readings, as it was the lactate/pyruvate ratio which is regarded as the better marker of metabolic strain of a given tissue rather than any one or both of these metabolites in isolation.

4.2.2 Statistical analysis

Statistical program for Social Statistics (SPSS) version 21.0 (IBM) was used for statistical analysis. Comparison of median distribution of Lactate, Pyruvate and L/P ratio between groups at each sampling time point was carried out with 2-independent samples Mann-Whitney U test. The Friedman test for k-dependent samples was applied to compare the trend of Lactate, Pyruvate and L/P ratio within each group. Significance was assigned at $p < 0.05$ at 95% confidence interval.

4.3 Patient and graft characteristics

In this study, a total of 30 liver grafts were studied (DCD; n=10 and DBD; n=20). The DCD grafts were procured according to the United Kingdom guidelines, and following the treatment withdrawal donor warm ischaemia time (dWIT) was calculated from the onset of systolic blood pressure < 50 mmHg or oxygen desaturation measured by pulse oximetry $< 80\%$ (whichever came first) to the time of institution of the cold perfusion in the donor. Grafts were procured and cold stored as described in the Chapter 2. The median dWIT time was 22 (13 – 28) minutes in the DCD grafts. Among the recipients receiving these grafts, the disease aetiology and the indication for LT were varied however there was a roughly equal distribution of cases present between the DCD and DBD groups. The recipient demographics and the indications for the LT are summarized in table 4-1.

Table 4-1: Demographics of liver transplant recipients, donors and liver allografts between DCD and DBD groups in the study group; both groups are comparable for donor, graft and operative characteristics apart from the dWIT

	DCD group (n=10)	DBD group (n=20)	Significance
Recipient age (y)	55 (41 – 66)	55 (26 – 66)	
Indication for transplant ¹			-
- ALD	03	06	
- HCV	03	05	
- HBV	02	01	
- PBC	01	03	
- PSC	-	03	
- OTHER ²	01	02	
MELD at transplant	12 (7 – 22)	16 (6 – 26)	
Donor warm ischaemia time (dWIT)	22 (13 – 28)min	N/A	-
CIT elapsed prior to sampling (median/range)	250 (44-357)min	238 (53-534)min	0.62*
Total CIT (median/range)	407 (257-651)min	464 (284-817)min	0.32*
Total microdialysis sampling duration (median/range)	208 (150-380)min	227 (101-307)min	0.26*
Implantation time	36 (30-65)min	41 (31-59)min	0.70*
Macrosteatosis of the grafts (t-1)			N/A
- none	02	03	
- mild	08	16	
- moderate	-	01	
- severe	-	-	
Microsteatosis of the allograft biopsy (t-1)			N/A
- none	01	02	
- mild	08	15	
- moderate	-	02	
- severe	01	01	
Degree of glycogen depletion (t-1)			N/A
- no depletion	-	04	
- mild	02	05	
- moderate	05	07	
- severe	03	04	

¹ Hepatocellular carcinoma was the primary indication in n=5 and n=4 in DCD and DBD groups respectively; ² other indications included Wilsons Disease, Polycystic disease and Non-alcoholic steatohepatitis, *Mann-Whitney U test; significance p=0.05 at 95% confidence interval

Liver grafts in both groups had been stored in the cold phase for an equal amount of time prior to the insertion of the microdialysis catheter (250min and 238minutes respectively for DCD and DBD grafts; $p=0.619$). The median sampling duration between the two groups, and the final overall CIT was not different between the two groups ($p=0.260$ and $p=0.328$ respectively). The implantation technique of liver grafts was standard in both groups and there was no significant difference in implantation time between the groups (table 4-1)

Histological examination of the graft biopsies obtained during the cold phase revealed presence of low degree of steatosis. This may reflect the selective and cautious use of liver grafts in the transplant setting owing to the adverse effects that are associated higher of steatosis. None of the grafts had severe macrosteatosis, whilst only one graft from each group had severe microsteatosis. Whereas more strikingly in the histological assessment, the degree of glycogen depletion appeared to be more abundant in the DCD grafts; 8/10 (80%) grafts in this group had moderate or severe glycogen depletion compared with 11/20 (55%) in the DBD group at cold storage.

4.4 Results

4.4.1 Interstitial lactate and pyruvate level

The DCD liver grafts had significantly higher lactate levels compared with DBD grafts during cold storage sampling [11.6 (0.4 – 27.0) mmol/l vs. 1.2 (0.2 – 6.0) mmol/l; $p=0.015$; Mann Whitney U test]. This difference was seen only in the cold storage microdialysis sampling and the first sample immediately post reperfusion did not see any significant difference between the interstitial lactate levels due to rapid clearance. This rapid clearance continued in these grafts at each 6 hour interval up to 48 hours in both groups (figure 4-6). Lactate levels were significantly reduced

following the reperfusion compared with the cold phase sampling in both DCD and DBD grafts ($p=0.020$ and $p=0.001$ respectively; Friedman test).

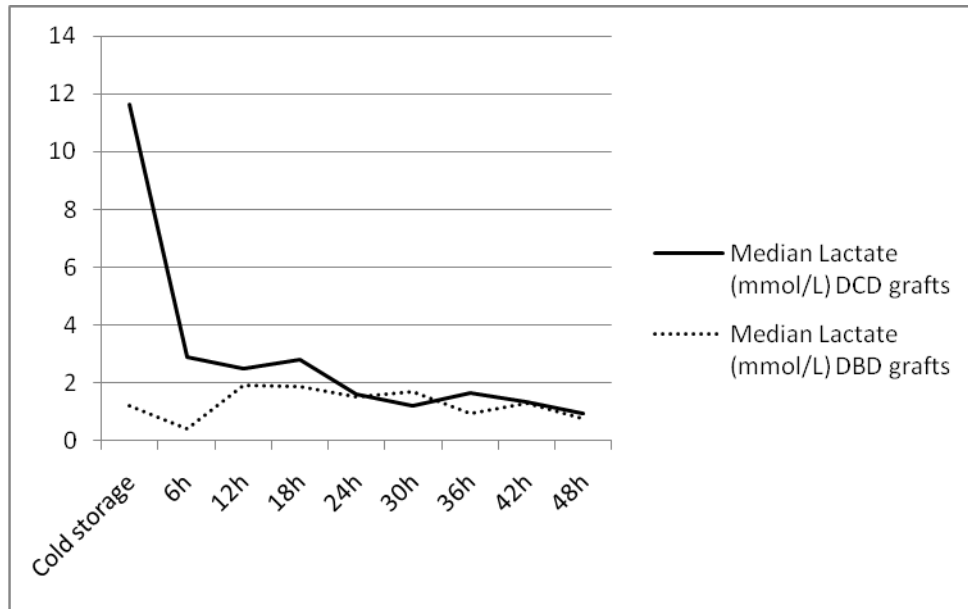

Figure 4-6: Median lactate levels in microdialysate samples obtained from cold phase sampling through to 48hours post reperfusion; comparison between graft types ($p<0.05$)

The median pyruvate level or distribution was not different between the DCD and DBD grafts in the cold phase sampling, although there was a tendency for low pyruvate levels in DCD grafts [10.5 ($2.0 - 47.0$) $\mu\text{mol/l}$ vs. 20.1 ($1.0 - 30.0$) $\mu\text{mol/l}$ respectively, $p=0.198$; Mann-Whitney U test] (Figure 4-7). Pyruvate levels of the grafts in both groups progressively increased at 6 hour interval samples from the time of reperfusion ($p=0.001$; Friedman test)

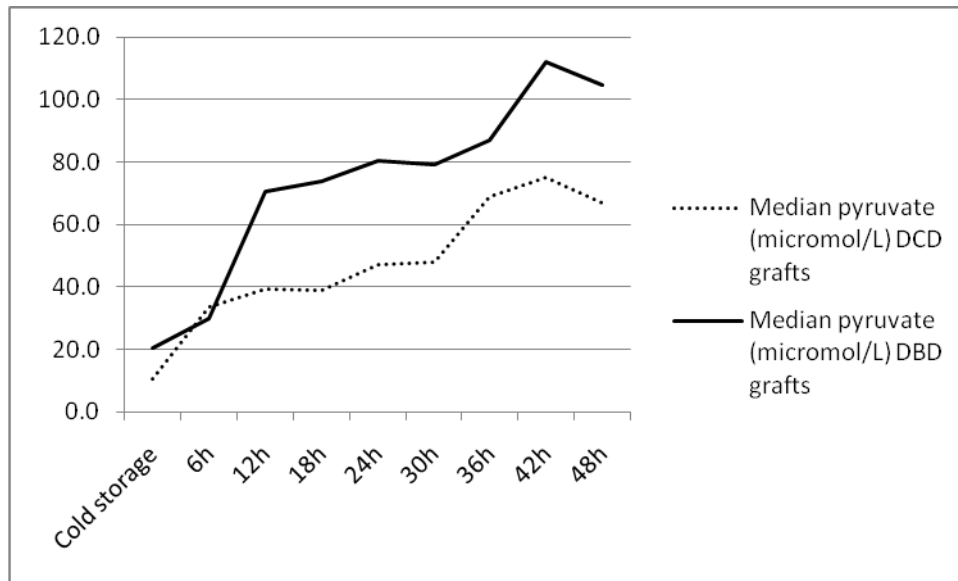

Figure 4-7: Median pyruvate levels in microdialysate samples from cold storage sampling through to 48hours post reperfusion; comparison between graft types showing that both DCD and DBD grafts had lower levels pyruvate (p=n.s) at the end of the cold storage and these were progressively replenished upon reperfusion.

Calculated lactate/pyruvate (L/P) ratio (median) in the DCD grafts was 792 (120-2100) and was significantly higher than that of DBD grafts [38 (6-863); p=0.001, Mann Whitney U test] in the cold phase (Figure 4-8). The lactate/pyruvate ratio in the DCD group of grafts rapidly declined upon reperfusion and normalized after 12 hours of reperfusion (Figure 4-9).

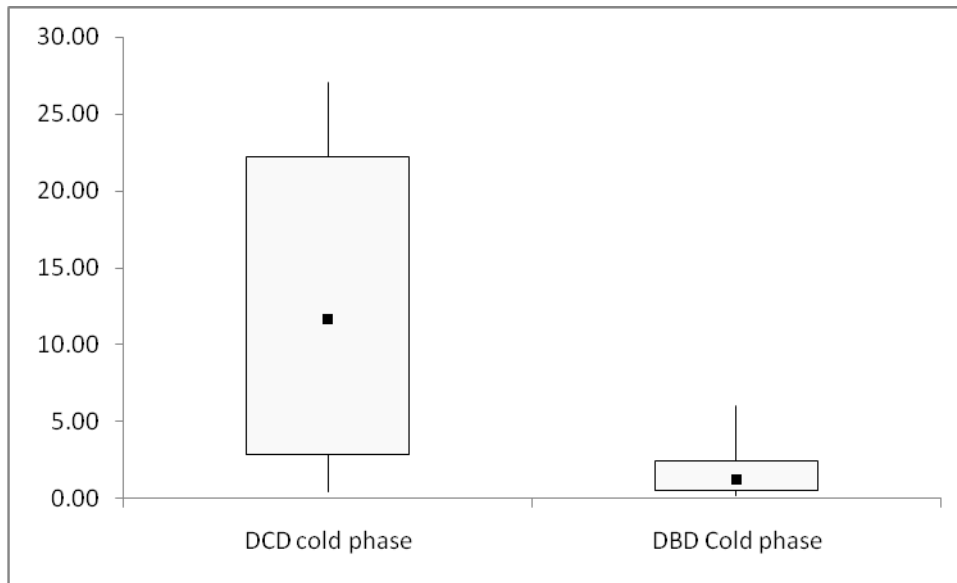

Figure 4-8: Comparison between calculated lactate/pyruvate ratio between DCD and DBD grafts during the cold phase sampling; DCD grafts had greater energy depletion represented by higher lactate/pyruvate ratio in the cold phase ($p < 0.05$)

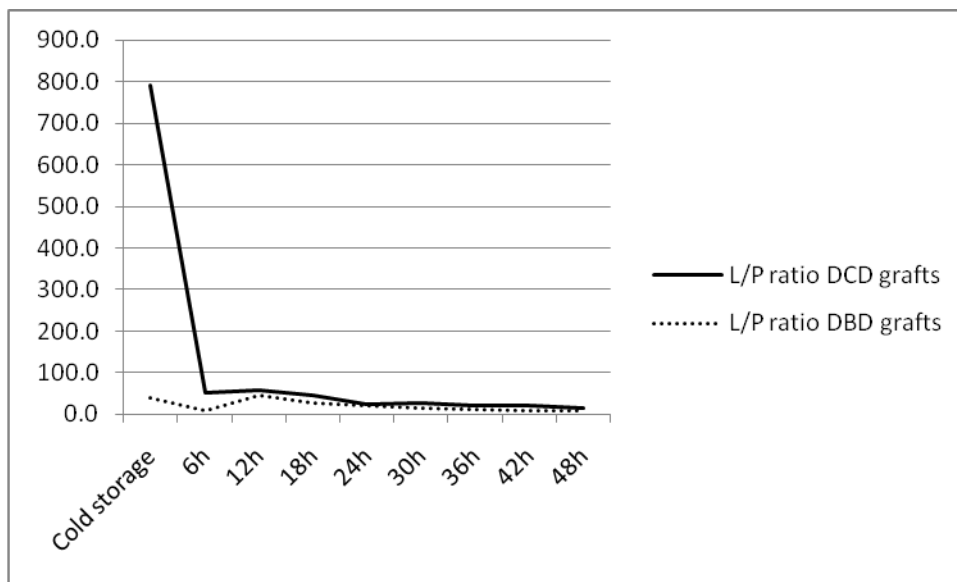

Figure 4-9: comparison of lactate/pyruvate (median) trends between the DCD and DBD grafts from cold storage through to 48hours post reperfusion; the higher lactate pyruvate ration present in the DCD grafts in the cold phase rapidly reversed and comparable ratios are seen upon reperfusion

4.4.2 Glycerol levels

The DCD grafts yielded slightly higher levels of glycerol during cold phase sampling compared with DBD grafts [225.1 (12 – 585) $\mu\text{mol/l}$ vs. 127.5 (11 – 1303) $\mu\text{mol/l}$ respectively], but this did not reach statistical significance ($p=0.700$; Mann Whitney U test). Rapid clearance of interstitial glycerol was noted in both types of grafts and beyond 12 hours of reperfusion and this is the likely result of washout of free glycerol from the reperfused graft and clearance from the circulation. Glycerol levels were normalised in both types of grafts beyond 12 hours (figure 4-10).

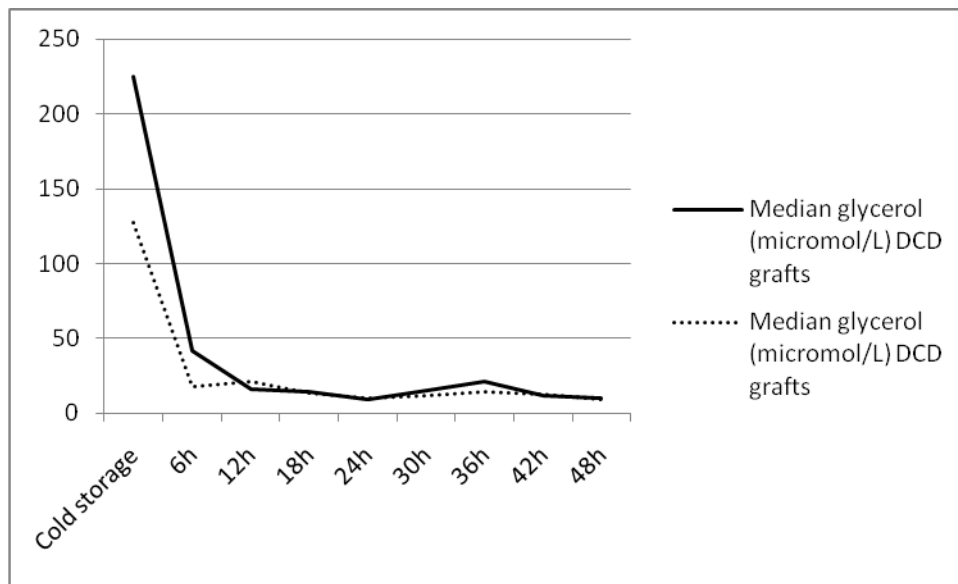

Figure 4-10: Comparison of median glycerol levels between DCD and DBD grafts from cold storage through to 48hours post reperfusion; DCD grafts had non-significantly elevated interstitial glycerol levels

4.4.3 Graft outcomes

In this selected cohort of patients, 4 cases of graft failure were observed. Three cases (DCD, $n=2$ and DBD, $n=1$) of graft failure were attributed to PNF, whereas in the remaining case the graft function and patient recovery were uneventful until the 8th post operative day when the patient suddenly developed massive non-thrombotic

infarction (NTI). The L/P ratios of these patients were plotted against the median L/P ratio of the entire cohort (figure 4-11). The median L/P ratio in the cold storage sampling in those with good early graft function (54.2) was lower than actual values in all 4 cases of graft failure (ranged between 143.5 – 1543). This was not statistically tested due to small sample size. The t-1 allograft biopsies of PNF cases showed moderate (grade II) in n=2 and in the remaining case severe (grade III) glycogen depletion. All three post reperfusion biopsies (t0) showed severe glycogen depletion.

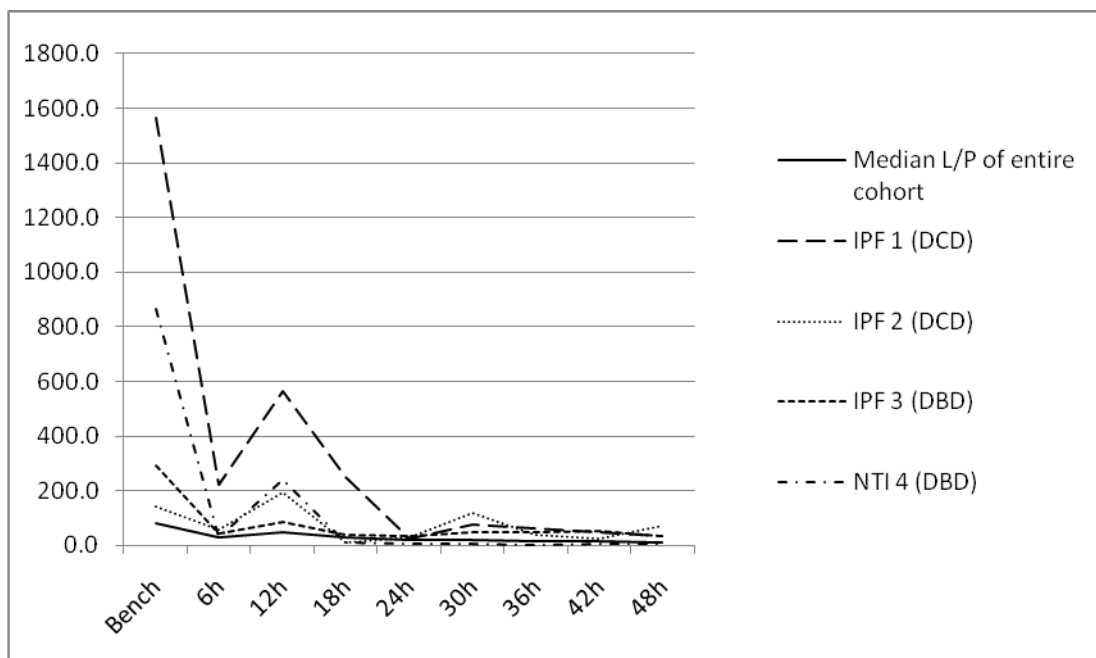

Figure 4-11: Comparison of median lactate/pyruvate levels of failed allografts due to poor function against those with successful outcomes; the bottom straight line represents the median values for lactate/pyruvate in all successful grafts, and the failed allografts showed greater lactate/pyruvate ratios compared with successful grafts

4.5 Discussion

Previous studies from our research group documented changes in the glucose metabolism pathway from the donor operation to cold storage of liver grafts obtained from DBD donors and increased L/P ratio during the cold storage has been

attributed to severity of IR injury (Nowak et al. 2002c;Silva, Murphy, Richards, Wigmore, Bramhall, Buckels, Adams, & Mirza 2006b;Silva et al. 2008). Whilst complimenting some of the findings of those studies, the presented data in this study reports the key differences that exist in basic metabolism with reference to DCD and DBD grafts. Apart from the inherent differences surrounding organ donation in DCD grafts with relevance to dWIT, all grafts in this study were comparable in terms of macroscopic quality of the graft, microscopic appearance (macro-steatosis) and both CIT and implanatation times. In this regard, the metabolic changes discovered in the cold storage in this study may be attributed to the added dWIT in DCD grafts, which is the key difference between the two types of grafts.

The higher lactate/pyruvate ratio in this study was primarily due to intial higher lactate levels in the interstitial space of the DCD grafts. Though the pyruvate levels were relatively lower in the DCD grafts, these grafts were not totally depleted of primary energy substrate which was reassuring finding that may have led to the successful outcomes in the majority of DCD grafts. Higher lacate levels could be explained by the lack of tissue perfusion following treatment withdrawal of DCD donors. Hypotension and reduced oxygen saturation both contribute to lack of oxygen delivery at tissue level. This in turn leads to slowing down of oxidative metabolism and switching on the anaerobic metabolic pathways to generate ATP that maintains cellular integrity(Brinkkoetter et al. 2008;Vajdova et al. 2002). Whilst the donor core temperature mainatined at room temperature near the “agonal phase”, cellular metabolism proceeds at the usual rate until the organs are cooled, hence the increased demand for intracellular energy. Higher lactate is thus generated in DCD grafts by more and more pyruvate being metabolised through anaerobic metabolism.

Tissue acidosis is detrimental to cellular viability and persistent acidosis augments cellular injury by widespread apoptosis. The mechanisms involve so called of mitochondrial permeability transition (MPT) pathway and pH paradox (Lemasters et al. 1998). Interstitial acidosis is inevitable in cold preservation of organs. The basic

metabolism within cellular systems is significantly reduced, but not completely halted by hypothermia. Each 10°C degree drop in the environment is likely to reduce the metabolism by 1.5-2.0 fold, thus liver grafts stored in 0-4°C prior to the implantation are likely to retain up to 10% of basic metabolism, energy for which is primarily driven by anaerobic metabolism (Belzer & Southard 1988). Upon reperfusion of liver grafts in the new recipient, reversal of energy balance occurs with rapid restoration of pyruvate through glycolysis that enter the Krebs cycle for oxidative metabolism (Takada, Taniguchi, Fukunaga, Yuzawa, Otsuka, Todoroki, Iijima, & Fukao 1997). Until this phase occurs, anaerobic metabolism continues with continuous production of metabolic waste lactate, which is primarily responsible for tissue acidosis (Dutkowski et al. 1998). Data in this study is insufficient to attribute the graft failures to increased lactate and L/P ratio; however it should be noted that all three PNF grafts had initial high L/P ratio during the cold storage and includes one DBD graft. The association between higher L/P ratio and PNF should therefore be further studied.

Relative increase in interstitial glycerol probably reflects higher degree of cellular injury in DCD grafts in the presence of acidosis (Boutillier 2001; Monbaliu et al. 2008; Vollmar et al. 1994). This increased glycerol levels may indicate increased cell lysis by apoptosis however this does not appear to be overwhelming in DCD grafts, again a reassuring finding in the liver grafts used in the transplantation setting (Hillered et al. 1998; Hogberg et al. 2012a; Hogberg et al. 2012b; Nowak, Ungerstedt, Wernerman, Ungerstedt, & Ericzon 2002c). The finding of higher interstitial lactate, L/P, pyruvate and the trend towards increased glycerol in DCD grafts probably provided more insights into the metabolic changes in the DCD grafts during cold preservation. These observations are consistent with previous animal models examining ischaemia reperfusion injury through microdialysis (Nowak et al. 2003b). Traditional organ preservation fluids have been designed to minimise the tissue acidosis being built up during cold storage (Straatsburg et al. 2002). Increased acidosis in DCD grafts prior to the commencement of organ preservation is probably the hallmark difference between the two types of grafts, and the buffering capacity of

the traditional perfusion is probably insufficient to cope with the existing extent of interstitial acidosis. This data probably calls for further studies in minimising graft acidosis in DCD grafts by intervention prior to the organ procurement or during cold preservation. These methods may include machine perfusion or in-situ regional normothermic perfusion where the behaviour of the potential graft may be further assessed and if required modulated (Brockmann, Reddy, Coussios, Pigott, Guirriero, Hughes, Morovat, Roy, Winter, & Friend 2009; McLaren & Friend 2003).

In summary, the data herein examines the key differences in the basic cellular metabolism in liver allografts, where DCD grafts have a higher interstitial lactic acidosis and L/P ratio during cold storage. Rapid clearance of lactate is noted following reperfusion of the grafts, and after 48 hours of reperfusion, no significant difference existed between the functioning DBD and DCD grafts. There is a tendency towards increased glycerol levels in DCD grafts denoting higher degree of cellular injury, and the non-functioning liver grafts had above average interstitial acidosis. These findings suggests further studies on modulation of basic energy levels in the grafts along with improved preservation techniques to avoid unwarranted severe acidosis.

CHAPTER 5 KEY METABOLITE FEATURE DIFFERENCES BETWEEN DCD AND DBD LIVER GRAFTS IDENTIFIED THROUGH CEAD BASED METABOLOMICS

*The work outlined in this chapter was largely researcher's own work performed in collaboration with Dr. Doug Richards from the School of Clinical and Experimental Medicine at the University of Birmingham performing microdialysis sample analysis through CEAD. The contribution from the researcher included performing microdialysis sampling, clinical data collection. The researcher also initiated and developed links with the Bioinformatics and High-throughput Analysis Lab, Center for Developmental Therapeutics, Seattle Children's Research Institute, Seattle, Washington for bio statistical input, with data analysis and interpretation performed through clinical transplantation perspective. The researcher wrote the manuscript, with contribution by co-authors and the manuscript is provided in appendix 3; **OMICS. 2014;18(12):767-77. doi: 10.1089/omi.2014.0094***

5.1 Introduction

Moving on to the study of basic metabolomics aspects of the transplanted liver grafts we used the microdialysate samples from grafts to using coulometric electrochemical array detection. The laboratory analytical input for this part of the study was given by the School of Clinical & Experimental Medicine, College of Medical & Dental Sciences at the University of Birmingham. Chapter 2 described in detail the coulometric electrochemical array detection (CEAD) and statistical analysis techniques which were supported by external collaborators. The feasibility of CEAD

as an analytical platform was described in previous proof of principle study as outlined in chapter 3. To date this was the only clinical study involving CEAD in the liver transplant setting. Although CEAD analysis in the previous study failed to underpin any biomarkers, which was beyond the scope of pilot study, the present study involved a much larger group of liver grafts used in the clinical transplantation setting and we aimed to identify key metabolite feature differences through this approach.

5.2 Coulometric electrochemical array detection (CEAD)

All microdialysis samples were analyzed on the Coularray 5600A 16-channel metabolomics system, under the control of Chromeleon software (Thermo Fisher Scientific, UK). The column used was a Luna 5 μ C18(2) (100 x 4.6mm) (Phenomenex, UK), maintained at a temperature of 35°C. Mobile phase A consisted of 20mM sodium dihydrogen phosphate, and 1.5x10⁻⁴M sodium heptane sulphonic acid, adjusted to pH 3.2. Mobile phase B consisted of 95% (v/v) methanol, 5% deionised water, and 1.5x10⁻⁴M sodium heptane sulphonic acid. Mobile phase flow-rate was maintained at 800 μ l/min throughout and the gradient profile over the 45 min run time is shown in figure 5-1.

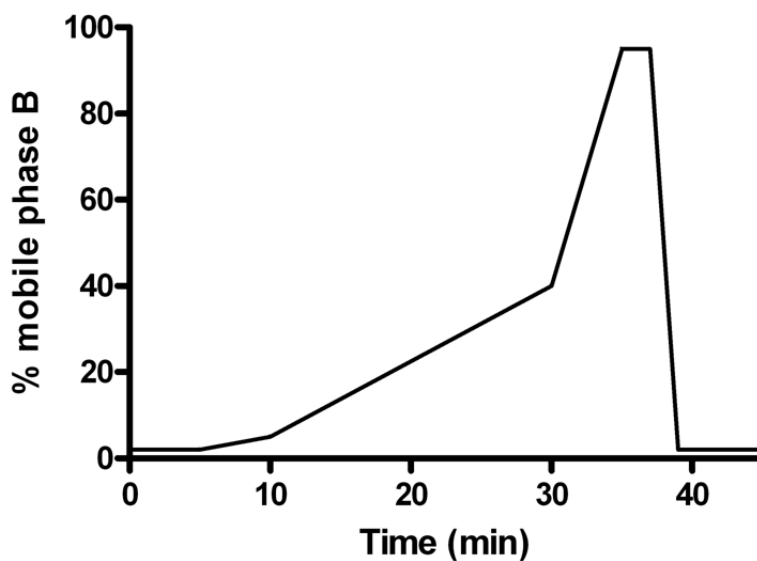

Figure 5-1: The curve displays the percentage of mobile phase B in the eluent over the 45 minute time period for each sample injection, the remainder being mobile phase A (Perera et al. 2014a)

In the coulometric array, cell 1 was set at a potential of -150 mV, cell 2 at 0 mV, with cells 3-16 ranging from 60 to 840 mV, in 60 mV intervals. Aliquots of the untreated microdialysis samples (5 μ l) were injected, and data acquisition stopped at 38 minutes. In addition, after every 10 sample injections, a reference standard containing 27 known electroactive compounds (each at a concentration of 5 μ M) was also injected to monitor for retention time drift and changes in electrode sensitivity. Each of these reference compounds was also characterised individually to determine its retention time under the above conditions, and the cell in which maximum oxidation occurred. Raw chromatographic data from individual microdialysis samples were stored as electrode-time maps, showing the signal from all 16 cells at the time that any peak was detected. In order to compensate for the inevitable small differences in retention times, both between and within batches, proprietary Coularray software was used to align the peaks from each microdialysis sample to a reference chromatogram, prior to pattern recognition analysis. This was achieved by the alignment of 3 amino acid peaks (methionine, tyrosine and tryptophan) that were present in every sample. Following peak alignment, the data were compressed to produce 866 time windows across the chromatogram (from 1.5 to 37.5 min). The

average signal output across all 16 cells of the array was displayed for each of these time windows.

5.2.1 CEAD sample and data analysis:

The CEAD data were formed into 3 analysis datasets consisting of the bench sample, the first post-reperfusion sample (mainly at 6 hours, but at 12 hours for 7 patients), and a time trend analysis set consisting of all post-reperfusion samples from 6 to 48 hours. Some patients did not have data in all datasets, 4 patients out of the 40 did not have a bench sample, 2 patients did not have a post reperfusion sample at 6 or 12 hours, and finally not all patients had samples analyzed at all post reperfusion time points; overall there were 280 post-reperfusion samples analyzed from 39 out of 40 patients. The 3 datasets were processed separately prior to data analysis.

First, each sample was normalized by dividing by the median signal intensity of each sample. This was done separately for a window above and a window below 7 minutes since signal intensity was much higher prior to 7 minutes. After normalization only windows where the maximum signal across samples was above a noise threshold were retained. Then windows were grouped into peaks using a heuristic peak finding algorithm (Rolinski et al. 2007). The algorithm identifies peaks by thresholding for the minimum height of peak and the drop between peaks required separating peaks. Fairly liberal parameters of 0.5% of the maximum peak to retain a peak and 5% drop between peaks to separate peaks were used to avoid merging separate metabolite peaks. Peak areas were calculated by summing all windows within a peak for each sample. A retention time was assigned using the window at the maximum of the peak. For putative identification of metabolite peaks, retention times were matched to the mean values above ($\pm 5\%$), and in addition the potential at which maximum oxidation occurred was matched (± 60 mV) (table 1). Metabolites containing more than one oxidisable group may have more than one maximum potential, and this is again characteristic for identification purposes.

The statistical analysis for the metabolite data was conducted using methods similar to those used previously for proteomics and microarrays (Higdon et al. 2013; Kolker et al. 2012; Smyth 2004). First, peak areas were log transformed. Bench and 1st reperfusion datasets showed similar spreads across patients after transformation but were re-centered using a mean correction. However, the time-trend dataset showed an increase in variation as post-reperfusion time increased therefore these data was also scaled by the standard deviation prior to analysis. T-tests and linear regression models were fit to individual peaks from the bench and first reperfusion datasets to find associations between metabolite peak intensity and donor type, cold-ischemia time, and the interaction between donor type and ischemia time. Expression ratios and P-values were reported for each comparison and metabolite peak. Repeated measures ANOVA was applied to each peak in the time trend dataset to determine if there were any overall trends versus post-reperfusion time and whether those trends varied with donor type and cold ischemia times. In addition, datasets were created for the mean of all post-reperfusion samples and the slope over time (calculated by a linear regression versus post-reperfusion time) for each metabolite peak in order to describe broad shifts in metabolite peak intensity and general upward or downward trends in intensity.

5.3 Patients and methods

A total of 40 adult patients undergoing elective liver transplants excluding those undergoing emergency liver transplantation, re-grafts or split liver transplants were included. A hepatic microdialysis catheter was introduced to the liver graft in the cold phase as described previously and cold storage samples were collected. This was done towards the end of the cold storage when the liver grafts arrived in the transplant centre for implantation, and during the bench procedure of liver graft preparation. As a result a variable time period of cold ischaemia time has been elapsed prior to the insertion of microdialysis catheter and this was recorded. A fresh catheter for post reperfusion sample collection was inserted to each studied graft

towards the end of the transplant operation and serial sample collection was carried out until 48 hours of reperfusion.

The study group consisted of 13 DCD liver grafts and 27 DBD whole liver grafts. The donor characteristics, the cold ischaemia time elapsed before insertion first microdialysis catheter, total cold ischaemia time, implantation time of each graft and overall ischaemia reperfusion injury assessed at the end of reperfusion obtained through a liver biopsy histological examination according to a previously described methods have been summarized in table 5-1. As with our previous study the disease distribution between the DCD and DBD group was heterogeneous, meanwhile the recipients' age distribution was similar. The DCD group had less advanced liver disease and this was due to the fact DCD grafts being marginal, physiologically more stable patients were selected for transplantation according to the unit's practice policy. Important finding was that the liver grafts were obtained from donors with otherwise similar characteristics in terms of age, BMI and graft steatosis. The only difference between these two groups was therefore the donor warm ischaemia incurred by the DCD donors which is related to the nature of organ donation. The median donor warm ischaemia time was 13 minutes whilst the maximum warm ischaemia time of the grafts in this cohort did not exceed the current accepted time limit of 30 minutes.

Similar time duration in the cold storage had been elapsed before insertion of the cold phase microdialysis catheter in each group and the cold phase sampling time was not different. Furthermore overall cold ischaemia time elapsed prior to the implantation was similar between the group and these findings reduced the bias of attributing any metabolite differences detected in CEAD analysis to increased cold ischaemic injury.

Four (n=4) liver grafts did not yield adequate samples material for CEAD analysis. This was due to the fact that bench phase was so quick that the liver graft was taken out of ice for implantation sooner. Total of 36 bench samples and 280 post-reperfusion microdialysate samples were analyzed.

5.4 Results

5.4.1 Overall metabolic activity detected by CEAD

Overall, the donor types do group together based upon the bench sample and first reperfusion metabolite expression patterns as can be seen in the clustering on top of figure 5-2. However, the metabolite patterns are not sufficient to completely separate the donor types (DCD vs. DBD).

5.4.2 Bench Samples – Donor Type and Cold Ischemia

In the analysis of the bench samples (table 5-2) below indicates there are metabolites that are over-expressed in DCD donors occurring at peaks around 3.8 minutes, 5 and 10 minutes having expression ratios near 3 fold. In addition, metabolites are over-expressed in the DBD donors at peaks occurring at 6.5, 12 and 14.5 minutes with expression ratios near 2 fold. When examining the trend with cold ischaemia there were peak at 12 and 27 minutes where metabolite levels increase with increasing cold ischemia time for the bench samples (roughly a 25 % increase with each 100 minute increase in time). These relationships are shown in figure 5-3 where the trend is evident but with large amount of variation about the trend.

Table 5-1: The recipient demographics, donor demographics and graft characteristics including steatosis, ischaemia times and degree of ischaemia reperfusion of assessed by histological grading following reperfusion

	Characteristic	DCD group (n=13)	DBD group (n=27)	Significance*
Recipient	Background liver disease			-
	- ALD	03	11	
	- PBC	02	03	
	- PSC	01	03	
	- Viral hepatitis (HBV/ HCV)	05	05	
	- NASH	01	-	
	- Polycystic disease	01	02	
	- Cryptogenic/Autoimmune	-	02	
	- Wilson's disease	-	01	
	Recipient age (median/range)	53 (41 - 66)	55 (26 - 67)	0.691
	Male; female ratio	07;06	17;10	-
	MELD at transplant (median/range)	12 (7 - 22)	16 (06-26)	0.045
Donor	Age (median/range)	51 (18 - 67)	52 (21 - 72)	0.512
	BMI	24 (20 - 31)	25 (17 - 36)	0.588
	Donor male: female ratio	04:09	11:16	-
	Donor warm ischaemia time	21 (13-28)	N/A	-
Graft	Macro-steatosis			-
	- No steatosis	02	04	
	- Mild	11	22	
	- Moderate	-	01	
	- Severe	-	-	
	CIT elapsed before bench microdialysis (min)	237 (44 - 357)	238 (53 - 534)	0.441
	Duration of bench microdialysis (min)	219 (150 - 380)	224 (101 - 333)	0.754
Overall CIT before reperfusion (min)	428 (256 - 651)	471 (284 - 817)	0.345	
Graft implantation time	40 (31 - 59)	37 (30 - 65)	0.197	
Degree of PRI by histology	- Mild	03	11	-
	- Mild-moderate	06	09	
	- Moderate	01	05	
	- Moderate-severe	02	01	
	- Severe	01	01	

Abbreviations: DCD – donation after circulatory death, DBD – donation after brain death, ALD – alcoholic liver disease, PBC – Primary biliary cirrhosis, PSC – primary sclerosing cholangitis, HBV – hepatitis B virus, HCV – hepatitis C virus, MELD – model for end stage liver disease, BMI – body mass index, CIT – cold ischaemia time, PRI – preservation reperfusion injury; N/A not applicable for DBD donors; * Significance p<0.05 at 95% confidence interval, Mann- Whitney U test for 2 independent samples

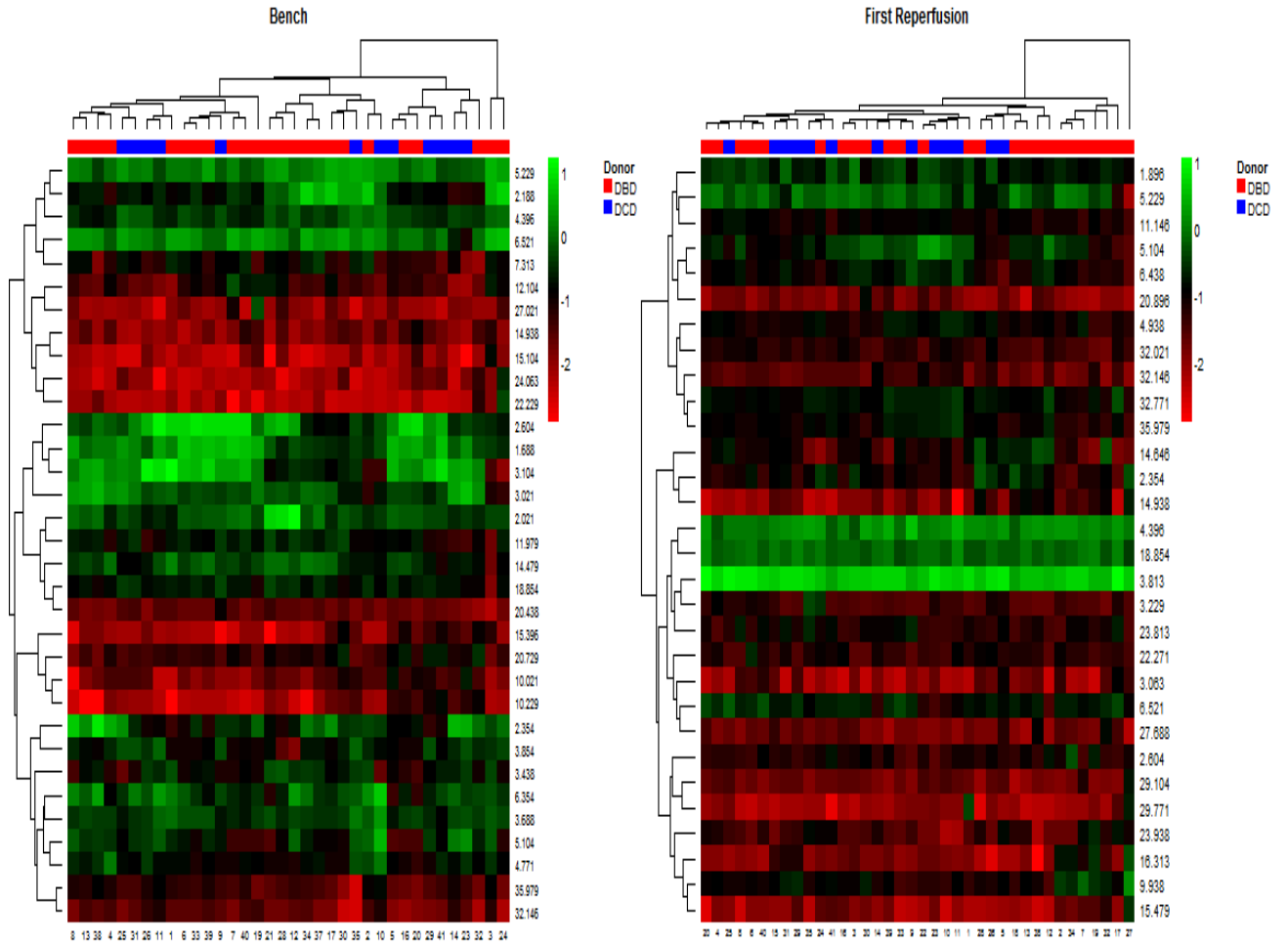

Figure 5-2: Heat map of normalised metabolite expression values; columns represent patient samples (Red - DBD, Blue - DCD) and rows represent the metabolite peaks labeled by their retention time. Samples and peaks are clustered by expression patterns (Perera et al. 2014a)

Table 5-2: Significant metabolite differences (metabolite denoted by corresponding retention time) between DCD and DBD grafts during cold storage sampling

Peak voltage range	ER Range	PV Range
3.85	3.04	.0003
5.10	2.81	.018
6.52	0.45	.003
10.02-10.23	2.21-3.10	.03-.01
11.98-12.10	0.57-0.39	.04-.009
14.48	0.48	.02
Overall Change with Cold Time (ER based on 100 min time difference)		
Peak Range	ER Range	PV Range
12.10	1.28	.03
27.02	1.34	.02

ER- expression ratio, given as DCD grafts against the DBD grafts – figure >1.0 represents over-expression whilst the converse denotes over-expression in DBD grafts, PV – partial variance

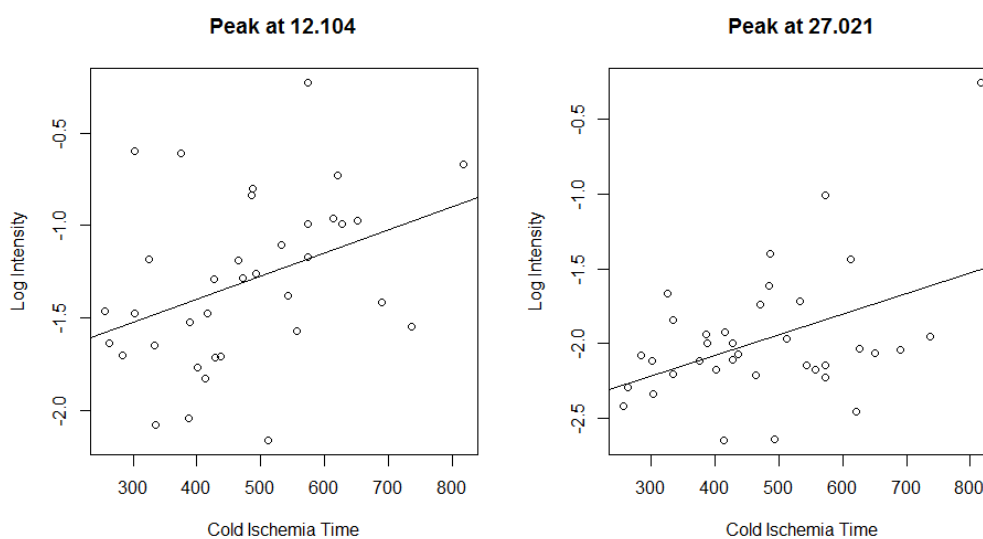

Figure 5-3: Overall trend of selected metabolites with cold ischaemia time elapsed against metabolite intensity for the cold storage samples

5.4.3 First Reperfusion Sample – Donor Type, Cold and implantation time

For the first reperfusion samples there were few overall differences between donor types. However, there were some trends with cold ischemia time and some of those trends differed by donor type. These are summarized in table 5-3. There were peaks at 2.3 and 22 minutes where metabolite levels decreased with increasing cold ischemia time (roughly a 20 % decrease with each 100 minute increase in time). In addition, there were peaks at 2.6 and 32.2 minutes where metabolite levels decreased for the DCD donors and increased for DBD donors (~20% for 100 minute increase) and there was another peak at 12.2 minutes where there was an increase only for DCD donors. The trends with cold ischemia time are illustrated in figure 5-4. There were also a few trends in the first reperfusion sample related to implantation time of the grafts. These include metabolite peaks at 16 and 29 minutes where metabolite levels increased with increasing warm ischemia time for DBD donors (roughly a 2 fold increase with each 10 minute increase in time). The relationships with warm ischemia time are shown in figure 5-5.

Table 5-3: Main differences observed in 1st reperfusion microdialysis sample; metabolites identified by retention time peak

Overall Change with Cold Time (ER based on 100 min time difference)			
Peak Range	ER Range	PV Range	
2.35	0.80	.03	
22.27	0.85	.03	
Change with Cold Time Differing by Donor Type(ER based on 100 min time difference)			
Peak Range	ER Range	PV Range	Donor Type
2.6	0.73	.001	DCD
2.6	1.20	.001	DBD
32.15	.82	.03	DCD
32.15	1.16	.03	DBD
Change with Warm Time Differing by Donor (ER based on 10 min time difference)			
Peak Range	ER Range	PV Range	
16.313	2.4	.04	DBD
29.104	1.64	.01	DBD

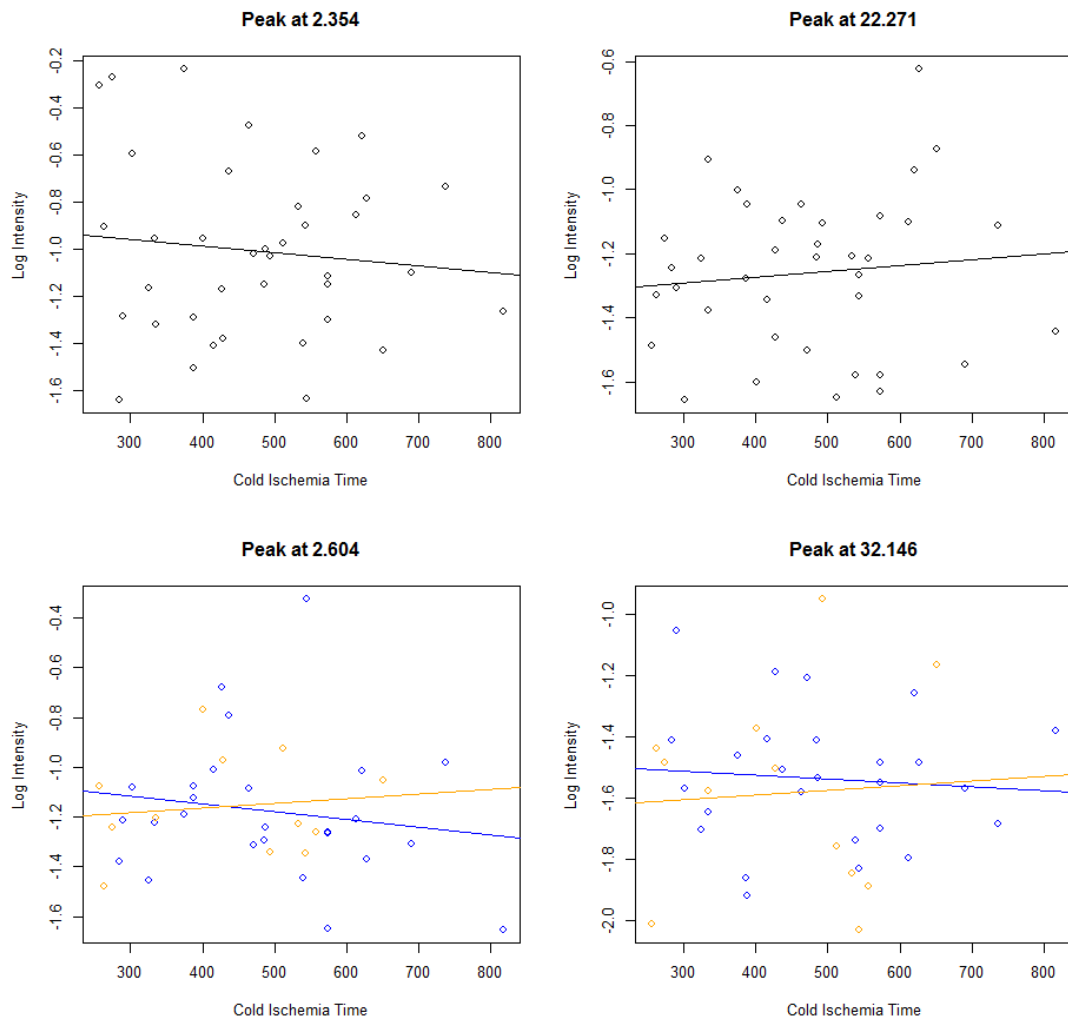

Figure 5-4: Trend of cold ischaemia time with metabolic intensity (selected metabolites) for the first reperfusion samples (Blue corresponds DBD donors, Orange DCD donors) through CEAD analysis of microdialysate samples.

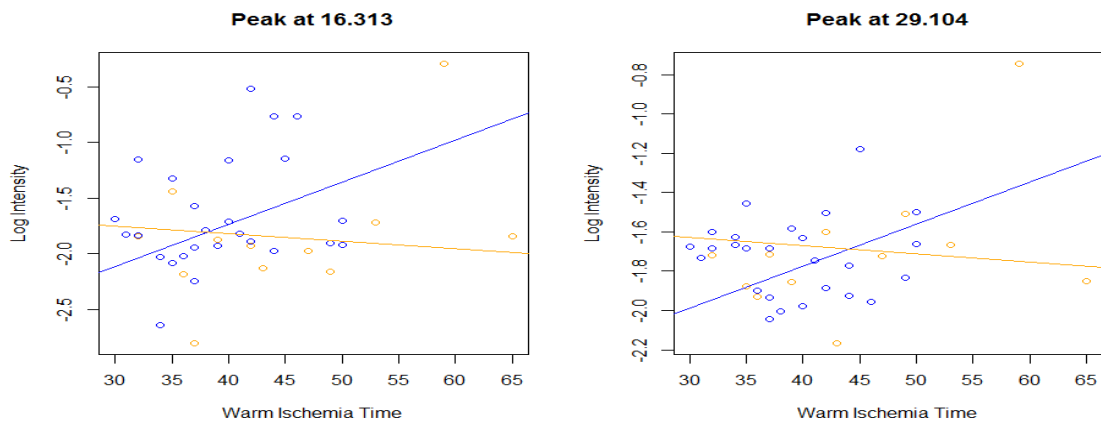

Figure 5-5: Trends of implantation time with metabolic intensity observed in the first reperfusion samples (Blue corresponds to DBD donors, Orange DCD donors)

5.4.4 Mean of Post Reperfusion Samples – Donor Type, Cold and implantation time

For the mean reperfusion as was the case for the first reperfusion samples there were few overall differences between donor types. However, there were several trends with cold ischemia time and some of those trends differed by donor type. These are summarized in table 5-4. There were peaks at 1.9 and 22 minutes where metabolite levels decreased with increasing cold ischemia time (roughly a 15 % decrease with each 100 minute increase in time). There were peaks at 10, 15.5 and 16.3 minutes where metabolite levels increased with cold ischemia time (20 to 50% for 100 minute increase). In addition, there was a peak at 2.6 minutes where metabolite levels decreased for the DCD donors. The trends with cold ischemia time are shown in figure 5-6. There were also trends in the mean post-reperfusion sample related to warm ischemia time. This includes peaks at 14.6 minutes where metabolite levels decreased with increasing warm ischemia time (roughly a 40% decrease with each 10 minute increase in time). There were peaks at 10, 15.4, 16.3,

36 and 27 minutes where metabolite levels decreased for DCD donors and increased for DBD donors. The trends with warm ischemia time are shown in figure 5-7.

Table 5-4: Key metabolite differences for Mean of post reperfusion samples (6-48hours) through CEAD analysis; metabolites identified by retention time

Overall Change with Cold Time (ER based on 100 min time difference)			
Peak Range	ER Range	PV Range	
1.9	0.85	.03	
10.02	1.21	.01	
15.44	1.22	.02	
16.23	1.46	.02	
22.27	0.85	.04	
Change with Cold Time Differing by Donor Type(ER based on 100 min time difference)			
Peak Range	ER Range	PV Range	Donor Type
2.6	0.83	.001	DCD
2.6	1.16	.001	DBD
6.44	1.25	.03-.04	DCD
Overall Change with Warm Time (ER based on 10 min time difference)			
Peak Range	ER Range	PV Range	
14.65	0.62	.03	
Change with Warm Time Differing by Donor (ER based on 10 min time difference)			
Peak Range	ER Range	PV Range	Donor Type
10.02	0.78	.005	DCD
10.02	1.61	.005	DBD
15.44	0.76	.001	DCD
15.44	1.84	.001	DBD
16.23	0.47	.001	DCD
16.23	2.67	.001	DBD
25.44	0.77	.02	DCD
25.44	1.2	.02	DBD
27.69	0.83	.02	DCD
27.69	1.34	.02	DBD
32.1-32.35	1.7-1.46	.001-.004	DCD

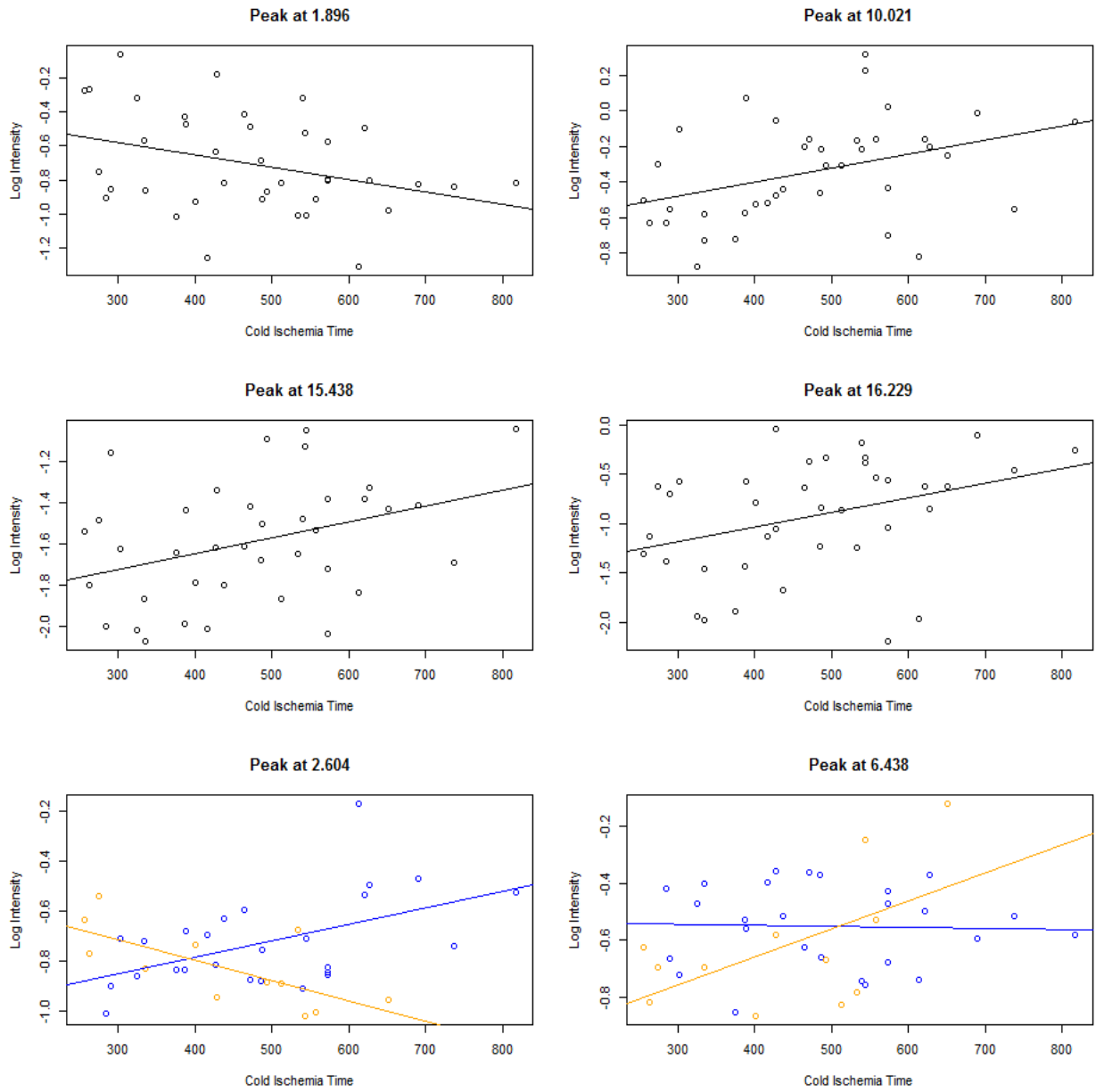

Figure 5-6: Trend of cold ischemia time with metabolite intensity for the mean of reperfusion samples. Blue corresponds to DBD donors and orange DCD donors.

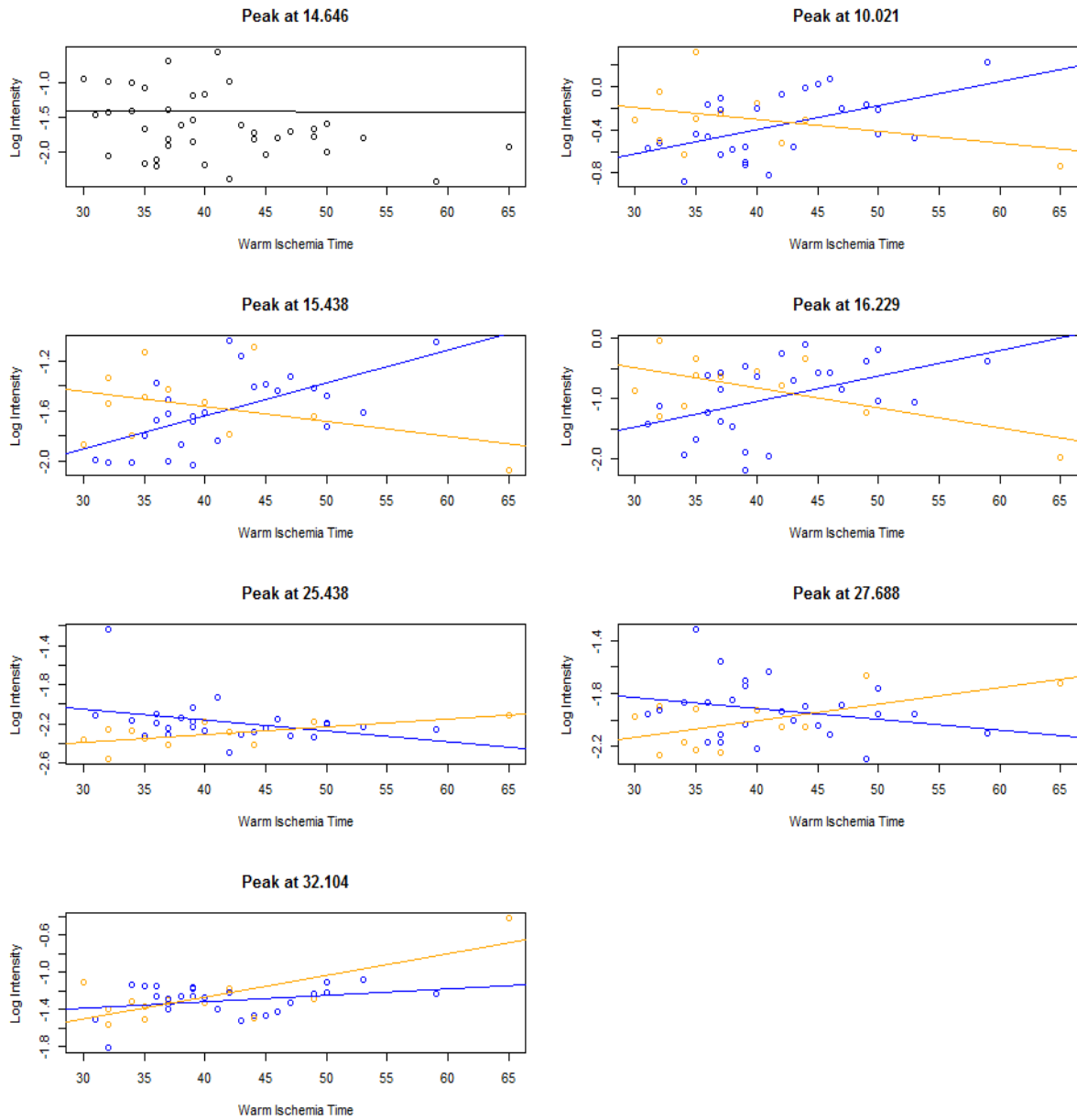

Figure 5-7: Trend of warm ischemia time with metabolite intensity for the mean of post reperfusion samples. Blue corresponds to DBD donors and orange DCD donors.

5.4.5 Differences in Patients with Poor Graft Function patients for Bench, First Reperfusion and Mean Reperfusion Samples

Overall metabolite difference of failed allografts versus successful allografts was compared across the different samples. However, there were only 4 patients with poor graft function in the dataset so the results should be viewed with caution. Also, the effect of patient type on ischemia time differences was not analyzed due to this small number. Overall, there were a few differences. These are detailed in table 5-5. In the bench samples at peaks occurring at 2.2, 6.5, 7.3 and 12 minutes metabolites were under expressed in PNF patients while they were over expressed at peaks occurring 3 and 10 minutes. There were not strong differences in the first reperfusion sample whilst there were some additional differences in the mean post-reperfusion samples as outlined in the table 5-4.

Table 5-5: Overall metabolite peak differences of failed allografts and expression ratio of such peaks.

The peak at 10.23minutes has the highest expression ratio and identified as kynurenine

Bench Samples		
Peak Range	ER Range	PV Range
2.19	0.15	.02
3.02	3.5	.03
6.52	0.2	.00005
7.31	0.26	.009
10.23	4.1	.04
11.98-12.1	0.41-0.29	.03-.02
Mean of Post-Reperfusion		
Peak Range	ER Range	PV Range
5.1-5.23	1.99-1.97	.002-.06
32.104	2.18	.0002

5.5 Summary of main metabolite differences

The reference metabolite table used in the CEAD analysis described in Chapter 2 and the above mentioned metabolic peaks were identified and against the reference table. Table 5-6 summarises the key metabolic differences between DCD and DBD grafts. In summary, 3 patterns of metabolite expression could be seen – over expression, concordant or discordant increase or decrease in metabolites in relevance to the cold ischaemia time. Of the metabolites over expressed, Xanthine, Uric acid and Kynurenine are over expressed nearly 3-fold in DCD grafts towards the end of cold ischaemia; however the only putatively identifiable metabolites over expressed in DBD grafts were 3-Nitrotyrosine (3-NT) and 4-Hydroxy-3-methoxymandelic acid (HMMA). Differential expression of Methionine was noted in the first reperfusion sample between the graft types, and two other unknown metabolites (occurring at retention times 2.35 and 22.7minutes) gradually declined with increasing cold ischaemia time. Both Xanthine and 3-NT gradually declined in both graft types meanwhile Kynurenine showed a slow rise following reperfusion.

Table 5-6: Summary of key metabolites and differences observed in during each phase post reperfusion with relevance to the different graft types.

Metabolic peak retention time (mV)	Putative metabolite	Main difference observed phase	DCD grafts	DBD grafts
2.35	Unknown	1 st Reperfusion sample	20% decline with each 100min increase in CIT	20% decline with each 100min increase in CIT
2.6	Methionine	1 st Reperfusion sample	reduced by 20% with each 100min increase in CIT	Increased by 20% with each 100min increase in CIT
3.8 – 3.85	Uric acid	Bench phase	over expressed by nearly 3 times	-
		Post reperfusion time trend	Significantly differ in the post reperfusion phase (p=0.001)	-
5.0 – 5.2	Xanthine	Bench phase	over expressed by nearly 3 times	-
		Post reperfusion time trend	gradually reduced over the time	Gradually reduced over the time
6.5	HMMA (weak)	Bench phase	-	Over expressed nearly 2 times
10.1	Kynurenine	Bench phase	over expressed by nearly 3 times	-
		Post reperfusion time trend	Slow rise post reperfusion	slow rise post reperfusion
12.0	Unknown	Bench phase	30% increase with each 100min increase in CIT	Over expressed nearly 2 times 30% increase with each 100min increase in CIT
14.4-14.6	3-NT (weak)	Bench phase	-	Over expressed nearly 2 times
		Post reperfusion time trend	Slow decline post reperfusion	slow decline post reperfusion
22.7	Unknown	1 st Reperfusion sample	20% decline with each 100min increase in CIT	20% decline with each 100min increase in CIT
27.0	Homovanillic acid	Bench phases	30% increase with each 100min increase in CIT	30% increase with each 100min increase in CIT

5.6 Discussion

The technological advances made in the past decade on separation and identification of small molecules, coupled with development of data analysis software paved the way for the metabolomic studies (Wishart 2005b). These are increasingly applied in both experimental and clinical medicine including identification of molecular targets in cancer treatment, biomarker discovery in the diagnosis of disease, and therapeutic drug monitoring (Bogdanov et al. 2008; Kaddurah-Daouk and Krishnan 2008; Rozen et al. 2005). Similarly metabolomics has been applied to solid organ transplantation although this is still in infancy (Clarke et al. 2003; Coca et al. 2007; Gok et al. 2003). The Coularray is a High Performance Liquid Chromatography (HPLC)/electrochemical detection system used for the analysis of redox-active metabolites and thus is highly relevant in situations where oxidative stress may occur including organ transplantation (Silva, Mirza, Buckels, Bramhall, Mayer, Wigmore, Murphy, & Richards 2006a). CEAD offers two major advantages as an analytical approach for metabolomics studies. The first is its very high sensitivity, which is far greater than that of nuclear magnetic resonance (NMR) studies, and superior to mass spectrometric (MS) studies. This allows it to detect metabolites present at a very low concentration, but which may still be clinically significant. The other advantage is its selectivity for redox-active metabolites, which may be of great value in the study of situations where oxidative stress may be a contributory factor. By avoiding the detection, and subsequent interference, of non-relevant metabolites that may be present at far higher concentrations, a more selective group of clinically-relevant metabolites may emerge. However, this may also be considered to be a disadvantage as, by definition, the metabolome encompasses the full range of metabolites present. However, there is no single analytical technique capable of achieving this, at all levels of sensitivity, and metabolomics studies often encompass more than one analytical approach (Koal and Deigner 2010).

Previously, through a proof of principle study we documented the applicability of metabolomic studies in liver transplantation (Hrydziuszko et al. 2010b). Moving further, this study examines the metabolomic changes in the process of human orthotopic liver transplantation – covering the journey through the cold storage to post reperfusion in a large study cohort. From a clinical and pathophysiological perspective, the primary difference between the DCD and DBD grafts is the known donor warm ischaemia time (dWIT) incurred by DCD donors prior to organ harvest (Ikeda et al. 1992). The deleterious effects dWIT has on the performance of a graft are such that DCD grafts are categorised as marginal grafts (Strasberg, Howard, Molmenti, & Hertl 1994). It is well known that this difference exists due to energy exhaustion prior to the organ preservation initiation, however in depth knowledge of metabolic changes that occur in DCD grafts are required to explore the avenues of maximizing the utility of this graft source (Minor et al. 1998). The data in this manuscript attempts to bridge this information gap and to our knowledge this is the first human study of metabolomics in liver transplantation comparing the key differences between DBD and DCD grafts.

The donor characteristics between the two groups in this study are similar. Graft steatosis has been previously reported to be a key parameter impacting the degree of PRI and subsequent clinical outcomes; in this study there was a very low degree of significant macro-steatosis, with one graft showing moderate macrosteatosis. In addition, the CIT elapsed prior to the insertion of microdialysis catheter, duration of bench sampling; the overall CIT and implantation times are comparable between the groups. Hence it is reasonable to assume the metabolic changes discovered in DCD and not DBD grafts are the result of or attributable to the dWIT superimposed on the DCD grafts.

This study identified several key metabolites that differ between grafts. Xanthine, Uric acid, and Kynurenine are the three significant metabolites that were over-expressed by DCD grafts in the cold phase. Although the former two metabolites have

been extensively studied in the past in ischaemia-reperfusion model, the finding of kynurenine is unique to our study. As the liver grafts have been perfused with identical preservation techniques and cold stored for a comparable time period, it is important to determine if these changes are indeed the result of warm ischaemic damage to the liver grafts. The DBD grafts over-expressed HMMA and 3-NT although it is not certain that the identification of these metabolites is correct. Other significant metabolites in relevance to the field of ischaemia reperfusion injury are those that increased with progressive increase in CIT. It could be speculated by increasing the CIT by nearly 5 hours the expression of Homovanillic acid along with another unidentified metabolite concentration may double, given the 30% rise for each 100minute increment of cold storage time. HMMA and homovanillic acid intermediary are end metabolic products of catecholamine metabolism, hence the significance of these findings may not be relevant.

Kynurenine, an intermediate metabolite of essential amino acid tryptophan is generated by two enzyme systems; this rate limiting step of tryptophan metabolism is catalysed by indoleamine 2-3 dioxygenase (IDO) and tryptophan 2-3 dioxygenase (TDO) (Knox 1951;Mehler and Knox 1950). IDO is virtually in almost all cellular systems, however TDO is liver specific (Knox and Mehler 1950). The increased expression of kynurenine in DCD grafts is therefore more likely to be due to increased TDO activity, as all other enzymes downstream in the metabolic pathway are present in abundance and TDO is the only inducible and rate limiting enzyme in this pathway (Taylor and Feng 1991). TDO is inducible by an increased amount of substrate itself, and also by hydrocortisone and glucocorticoids (Altman and Greengard 1966). The grafts studied were procured from identical situations with preservation solution devoid of tryptophan supplementation; in addition DCD donors did not receive high doses of steroids such as are usually given to the DBD donors. The slow rise in kynurenine in both types is probably explained by routine prescription of hydrocortisone in the immunosuppression medication (Young 1981;Young and Sourkes 1975), but none of these explain the over-expression of this metabolite in the cold stored DCD grafts. It is uncertain therefore if the TDO was

induced by hypoxia--to date no studies have confirmed this finding. A catecholamine surge in the donor and induction of TDO during the agonal phase of organ donation following the treatment withdrawal is a possibility. The immune- and cyto-protective effects of both IDO and TDO by degradation of tryptophan have been documented and further studies focusing this metabolite may be helpful (Mellor and Munn 2004; Terness et al. 2002).

Xanthine and Uric acid are formed by the enzyme xanthine oxidase through its action on the substrate hypoxanthine and a major pathway of purine nucleoside catabolism. Both these metabolites have been previously identified as biomarkers of ischaemic injury (Vajdova et al. 2000). During oxidative stress the enzymatic action of xanthine oxidase is increased with formation of reactive oxygen species (ROS) and uric acid. Although uric acid may be regarded as a scavenger against tissue injury, it is not known if uric acid is indeed the cause or effect. It is likely that the actual tissue damage is caused by ROS itself rather than uric acid and the latter is the metabolic by-product of an over-activated pathway. Several studies suggest uric acid as a marker of ischaemic damage of the liver grafts (Clavien et al. 1992), including occasional case studies reporting its increase in the presence of poor organ function following LT (Serkova et al. 2007). It is likely that tissue hypo-perfusion and hypoxaemia during the treatment withdrawal phase in DCD donors triggered the conversion of more inert enzyme xanthine dehydrogenase to xanthine oxidase (Brass et al. 1991). In this regard further investigation of enzyme xanthine oxidase during organ preservation, with emphasis on modulation of its enzyme activity in DCD donors could open avenues for further studies (Amador et al. 2007; Ishii et al. 1990; Wishart 2008).

A limitation of the present study is the failure to recognize three metabolite peaks occurring at the retention times of 2.35, 12.0 and 22.7 minutes. However, these metabolite peaks followed the similar trends in both types of liver grafts; therefore the clinical significance of these may be less relevant. The lack of information it

provides regarding unknown peak identification is a disadvantage of CEAD for metabolomics studies. Unlike NMR which may indicate functional groups present and MS which may provide a mass number, the identification of CEAD peaks is reliant on comparison of its chromatographic and electrochemical properties to known electroactive compounds from reference databases. Peaks of interest not identified by this process may be investigated further by fraction collection or replicating chromatographic conditions with MS detection, for example. The future of metabolomic studies in LT should probably focus on different approaches with recognition of biomarkers in different biofluids and hepatic tissue. A shot-gun approach to identify metabolites recognized in this study may be useful in further investigations; certain limitations apply to different analytical techniques. A combination of CEAD, NMR or FTICR mass spectrometry could be complementary to each other (Wishart 2008).

To summarize our findings, this study investigates the use of CEAD as an analytical platform to investigate metabolomic changes that occur through cold storage to post reperfusion injury in cadaveric liver transplantation. These results provide, to date, data for the largest human study group examined. The majority of the metabolomic studies reported in the literature involved experimental models however the data presented herein are accumulated through real transplantation settings. Moreover, the metabolite differences that exist between the DCD and DBD liver grafts are the key findings of this study, and in this regard the finding of kynurenine as a potential marker of aggravated ischaemic injury over-expressed by DCD grafts is novel. These findings have the potential to stimulate the scientific community to further explore these differences, with the eventual objective of graft modulation for improved outcomes. The authors aim to further analyze the significance of metabolites identified in this study through correlation with clinical factors and their ability to predict graft outcomes using statistical models. We have not presented the clinical outcome data in the presented manuscript for a number of reasons; as this is the only largest study on metabolomics in human liver transplantation, the primary objective was set as identifying metabolic differences in each stage from cold storage to

reperfusion of liver allografts and those exist between DCD and DBD grafts. With this view point, the focus was on presenting all the relevant data and results related to the basic experiment and analysis.

CHAPTER 6 FTICR BASED MASS SPECTROMETRY ANALYSIS OF DCD AND DBD LIVER GRAFTS USED IN CLINICAL LIVER TRANSPLANTATION

The work outlined in this chapter amounts to collaborative work. The researcher presenting the thesis was responsible for liver graft biopsy sampling during the operative procedures, clinical data collection and participated in sample extraction and analysis through FTICR, which was primarily carried out with collaboration with the School of Biosciences by Olga Hrydziusko under the tutelage of Jennifer Kirwan and Professor Mark Viant. Biostatistics support was provided by the same research group at the School of Biosciences in the clinical directions provided by the researcher presenting this thesis under the supervision by Professor Darius Mirza and other collaborators. This work is currently being prepared for publication.

6.1 Introduction

Identifying the metabolic differences between DCD and DBD liver grafts could significantly improve current clinical practise by identifying biomarkers of poor graft function prior to transplantation. Selection of grafts from donors that exhibit such metabolic biomarkers could assist in clinical decision making and the exclusion of those organs from transplantation, thereby preventing the adverse clinical sequelae after transplantation. This would also help those transplant programs that are reliant on cadaveric donor organs for transplantation by reducing the need to perform re-transplant operations on those who had failed liver grafts, minimizing the burden and demand for organs. Furthermore, identifying the metabolic differences between DCD and DBD liver grafts could help to identify the metabolic modifications of livers before and after the organ procurement from the donor that would improve the organ quality, an approach called metabolic therapy. This approach is justified by the

nature of current organ donation practice. In the United Kingdom alone there has been a steep rise in DCD donations in recent years. However, only 27% of liver grafts from these donors are used in clinical transplantation, with approximately 8% of these being excluded due to the high risk of primary non-function. In addition, the majority of grafts are not even procured due to the increased time elapsed between the treatment withdrawal phase and circulatory death, which is beyond the currently accepted criteria of donor warm ischaemia time (30 minutes). Relating the metabolic profiles of DCD and DBD liver grafts to the outcome of the transplantation could supplement and expand the traditional methods to predict organ function, in particular early on during the transplantation procedure.

Previous pilot study demonstrated the potential of Fourier transform ion cyclotron resonance (FTICR) mass spectrometry to detect a few thousand metabolic features (or peaks) in biopsies obtained from liver grafts in the cold and post-reperfusion phases of orthotopic liver transplantation (Hrydziuszko, Silva, PR Perera, Richards, Murphy, Mirza, & Viant 2010b). We observed and characterized changes in multiple metabolic pathways showing a rapid resumption of biochemical function within the grafts following reperfusion (Reich, Mulligan, Abt, Pruett, Abecassis, D' alessandro, Pomfret, Freeman, Markmann, & Hanto 2009). The extended study described herein represents a larger study group in comparison to the proof of principle study described in the chapter 3. Here, we expand considerably upon this initial investigation, specifically with the aim to investigate and characterize the metabolic differences between DCD and DBD liver grafts during two key phases of the liver transplantation, the cold storage phase (T₁, CP) and post-reperfusion phase (T₂, PR). We seek to reveal the underlying metabolic pathways associated with the clinical observation of reduced success of the DCD grafts.

6.2 Fourier Transform Ion Cyclotron Resonance – Direct Infusion (FTICR-DI) mass spectrometry

6.2.1 Basis of FTICR

Mass spectrometry is a novel analytical platform applied in the investigation of the metabolome and several techniques exist, and these include Fourier transform ion cyclotron resonance mass spectrometry (FTICR-MS), Gas chromatography mass spectrometry (GC-MS), liquid chromatography mass spectrometry (LC-MS) and direct injection mass spectrometry (DIMS) (Dunn 2008;Dunn and Ellis 2005). FTICR has the highest high resolution power compared with other analytical methods. Resolution power could be simply described as the ability to separate two signal peaks and for FTICR this is generally over 200 000(Guan et al. 1996;Ohta et al. 2010). This enables the mass analyser to detect greater number of metabolites present within a sample. The other advantage of the FTICR technique is the highest mass accuracy ($m_{calc} - m_{exp} / m_{calc} \times 10^6$), defined as the ability of a particular mass spectrometry analyser to accurately assign its mass closest to the theoretical mass value, and in the case of FTICR this could be in the range of less than 1 parts per million (ppm)(Schmid et al. 2000). Owing to these two properties of the FTICR technique, this increasingly being used to investigate complex biological systems and is an ideal tool for biomarker and metabolomics/proteomic studies (Zhang et al. 2014). Rather than molecular mass itself, FTICR-MS measures compounds based on their mass-to-charge ratio (m/z). The m/z ratio is calculated by measuring the frequency at which the ion processes in a fixed magnetic field, that can simply be described as the ion motion or the cyclotron frequency once excited in a magnetic field (Dunn 2008). These frequencies, which typically are in the 100 KHz to MHz range, can be very accurately measured as the ions pass near the detection plates (electrodes). This is a fundamental difference between FTICR and other analytical techniques is that, in most systems ions are detected as they hit the detection plates whereas in FTICR the frequency of ion motion is detected as they pass near the detection plates or electrodes. It is the modern electronics that makes it possible to accurately determine the mass within 1ppm difference increasing its resolution

power, therefore FTICR technology is increasingly used analytical studies where the investigation of smaller molecules. A further advantage of the higher resolving power over time-of-flight instruments is that it enables the study of ions of up to several hundred kilodaltons, allowing the study of large macromolecules such as proteins. A particular disadvantage however that associated with high resolution power of FTICR technique is the increased time taken for the analysis of samples.

A typical mass analyser has three key stages in its analytical pathway and the samples can be introduced in various forms either as gas, liquid or solid forms. The ionization technique then converts the metabolites present in the sample in to ion forms. This process occurs in either in the atmospheric or sub-atmospheric (vacuum) pressure, using any of the modes like chemical ionization, electron impact or electrospray ionization. Once the ions enter the mass analyser either physical detection (ions hitting the detection plates) or motion detection (detection of image current as ions pass near electrodes) occur and the resultant electronic signal is transformed in to a spectral pattern. In FTICR, ions are generated from the sample by injection, utilising an electrospray ion source (figure 6-1). The ions are then passed into the FTICR cell which located in the middle of a superconducting magnetic field combined with electronic field which are placed perpendicular to each other. This electro-magnetic arrangement is termed a penning trap and is where the mass analysis takes place (Heeren et al. 2004). Once the electromagnetic field is activated the ions are excited and exhibit a cyclotron motion that is dependent on the m/z of the ions and the strength of the magnetic field.

Within the ICR cell, ions with a particular m/z ratio form an ion cloud that travel in an orbital trajectory in magnetic fields. The path of this orbital trajectory or the circular motion occurs due to the Lorentz Force (Marshall et al. 1998). The ion cyclotron frequency is determined by several factors and these include the strength of the magnetic field, the charge of the ion and the actual mass. This cyclotron frequency is mathematically represented as $\omega_c = zB_0/\pi m$. B_0 , z and m are respectively denoted by the strength of the magnetic field, charge and mass of the ion. The efficiency of ion detection and mass resolution is further increased through excitation by a radiofrequency pulse making the ions move in a larger ion cyclotron

radius (Marshall, Hendrickson, & Jackson 1998). The final phase of ion detection is related to the cyclotron frequency of ions which is in turn measured by detecting an induced charge or an image current, as the ions pass near the detection plates. The induced charge can be caused by attraction or repulsion of the ions towards the detection plates and this alternative or oscillating current fades away with time (time domain)(Comisarow and Marshall 1974;Junot et al. 2010). Fourier transformation of the resulting signal converts to the time domain which is then converted to frequency domain generating a mass spectrum (figure 6-2). A typical FTICR mass spectrometry spectrum returns the m/z ratio on the x-axis and the relative intensity of the ion on the y-axis.

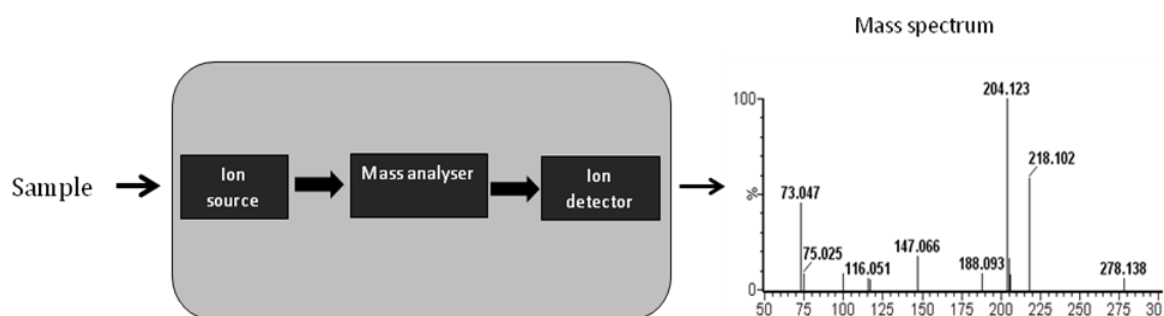

6-1: The schematic representation of basis of FTICT mass spectrometry (source: Department of Biosciences, University of Birmingham)

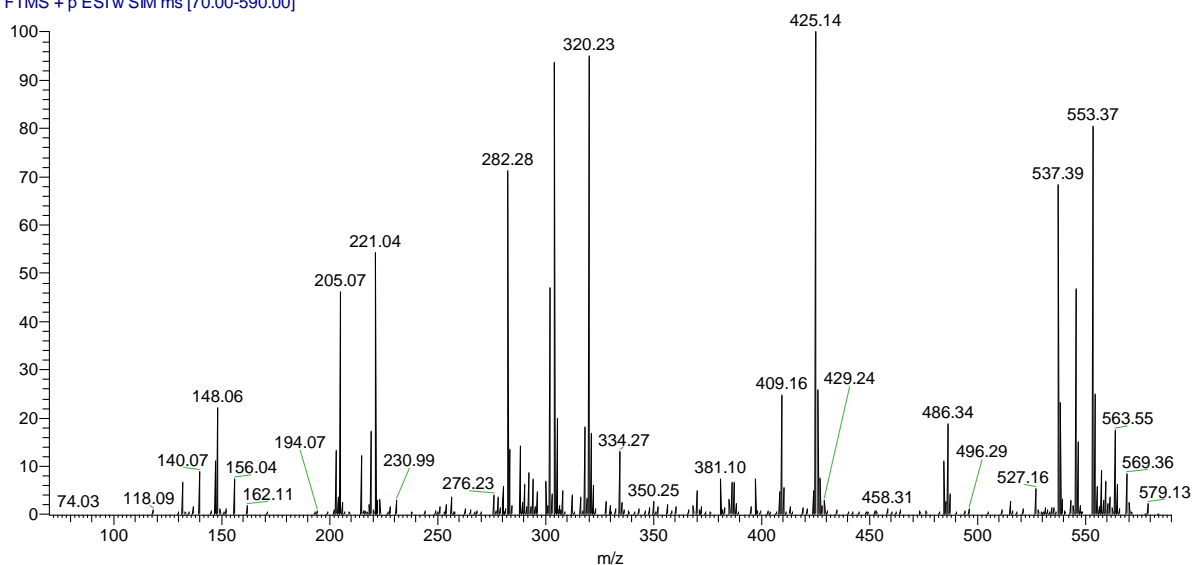

6-2: Typical example of a FTICR mass spectrometry pattern showing different metabolite peaks according to the respective m/z ratio

6.2.2 Mass spectrometer

The School of Biosciences at the University of Birmingham offers FTICR-MS facility through a latest LTQ Ultra design (Thermo Scientific) which has direct infusion capabilities and allows high throughput for large numbers of samples. This facility was provided for the FTICR-MS analysis by the collaborators disclosed earlier in this chapter (figure 6-3; courtesy Jennifer Kirwan, Department of Biosciences University of Birmingham). This equipment provides highly sensitive detection of ions with attomole range for peptides and selected ion modes (positive and negative) could be operated. Its mass detection ranges from 50 to 4000kDa with resolution Up to 1,000,000 molecules and 100,000 routinely used molecules. Its' ion detection system is comprised of a dual conversion dynode detector allowing digital electronic noise discrimination.

Fourier Transform Ion Cyclotron Resonance (FT-ICR) mass spectrometry facility in Birmingham

Thermo LTQ FT ultra

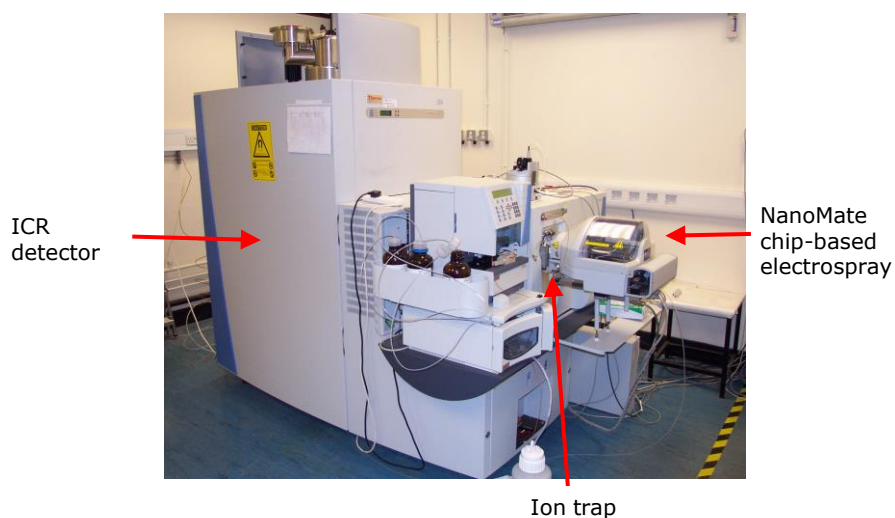

6-3: The Thermo LTQ FT Ultra mass spectrometer with key elements labeled (Image courtesy – Jennifer Kirwan, Department of Biosciences, University of Birmingham)

6.2.2.1 Tissue extraction for FTICR Mass Spectrometry Analysis

Tissue extraction from the liver allograft biopsies was done according to the sample extraction protocol designed for small samples (<10mg). This technique involves Methanol:Chloroform:water to separate polar metabolites of the extracted tissue following homogenisation of the tissue sample.

Equipment: Precellys 24 homogeniser

1.8ml glass vials with aluminium lined caps (Fisher TUL 520 006 J)

2ml Eppendorfs

Glass Pasteur Pipettes

Hamilton Syringes (Fisher 500 μ l)

Solvents: 100% MeOH (HPLC Grade)

100% CHCl₃ (Pesticide Grade)

100% HPLC grade H₂O

6.2.2.2 Tissue Extraction Protocol:

The frozen tissue is stored in Precellys tubes with beads in -80 freezer and the solvents used in the tissue extraction protocol were maintained at 4°C and kept on ice during the extraction phase. First MeOH is added at 32µl/mg of tissue and 12.8µl/mg of H₂O keeping precellys tubes on ice, and then the tubes were placed in the Precellys 24 homogeniser for 2 x 10s bursts at 6400 rpm. The homogenised mixture is then removed into a clean 1.8ml glass vial using a Pasteur pipette whilst maintaining the temperature of the glass vials on ice, 32µl/mg CHCl₃ and 16µl/mg H₂O added to each vial. Subsequently Vortex vials on full power for 30s before leaving on for further 10minutes. Finally the samples are centrifuged at 4000 rpm at 4°C for 10 minutes. At the end of the centrifugal phase samples are set on bench at room temperature for further 5 minutes that allow clear separation of the samples in to a biphasic sample with protein debris separating the upper (polar) and lower (non-polar) layers. Using a Hamilton Syringe, the polar phase is removed into 2 clean eppendorfs (1 positive, 1 negative) and if required for analysis the non-polar phase is also removed. Particular care is should be given here not remove any of the interface region, (1-2mm either side of the protein layer). The extracted samples are then dried using a Speed Vac Concentrator (~1h with no heat) and that can be stored at -80°C until needed.

6.2.3 FTICR data analysis

FTICR data was generated by the liver allograft biopsies that were prepared for metabolomics analysis as described previously (Reich, Mulligan, Abt, Pruett, Abecassis, D'alessandro, Pomfret, Freeman, Markmann, & Hanto 2009). In brief, biopsies were extracted using a methanol:chloroform:water method, separating the extracts into polar and non-polar fractions (Wu et al. 2008). In total, 80 samples liver biopsy samples were extracted and from these one quality control (QC) sample was prepared by pooling a fraction of each of the 80 extracts (which was then aliquoted into 11 identical fractions). The polar metabolite fraction of each sample was

analysed by ultrahigh resolution direct infusion nanoelectrospray FT-ICR mass spectrometry (Thermo Fisher Scientific, Pittsburgh, PA, USA; LTQ FT) from m/z 70 to 500, in positive ion mode, using the SIM-stitching approach (Southam, Payne, Cooper, Arvanitis, & Viant 2007) (figure 6-4). Each sample was analysed in triplicate. To minimise false positive metabolites in the data matrix (due to noise), only peaks present in at least 2 of the 3 replicate measurements of each sample were retained, and then only peaks present in at least 75% of all the samples were retained for further analysis (Payne, Southam, Arvanitis, & Viant 2009). This data processing also served to exclude any peaks in the mass spectra that arose from the drugs that were known to be administered to the donors and recipients. The final data matrix consisted of 1260 reproducibly detected peaks (rows) and 91 variables (80 biopsies and 11 quality control samples; columns). The matrix contained 9.29% of missing data which was imputed using a weighted k-nearest neighbours algorithm ($k = 5$) (Hrydziuszko and Viant 2012). Data were then normalized using the probabilistic quotient method (Dieterle et al. 2006) and subject to a generalised log transformation (prior multivariate analysis) to stabilise the technical variance across the peaks and hence to avoid the highest abundance peaks from dominating the multivariate analysis (Parsons et al. 2007). Putative metabolite names were assigned to the peaks based on their mass-to-charge ratio and taking into account commonly detected ions forms, including $[M-e]^+$, $[M+H]^+$, $[M+Na]^+$, $[M+^{39}K]^+$, $[M+^{41}K]^+$, $[M+2Na-H]^+$, $[M+2^{39}K-H]^+$ and $[M+NH_4]^+$.

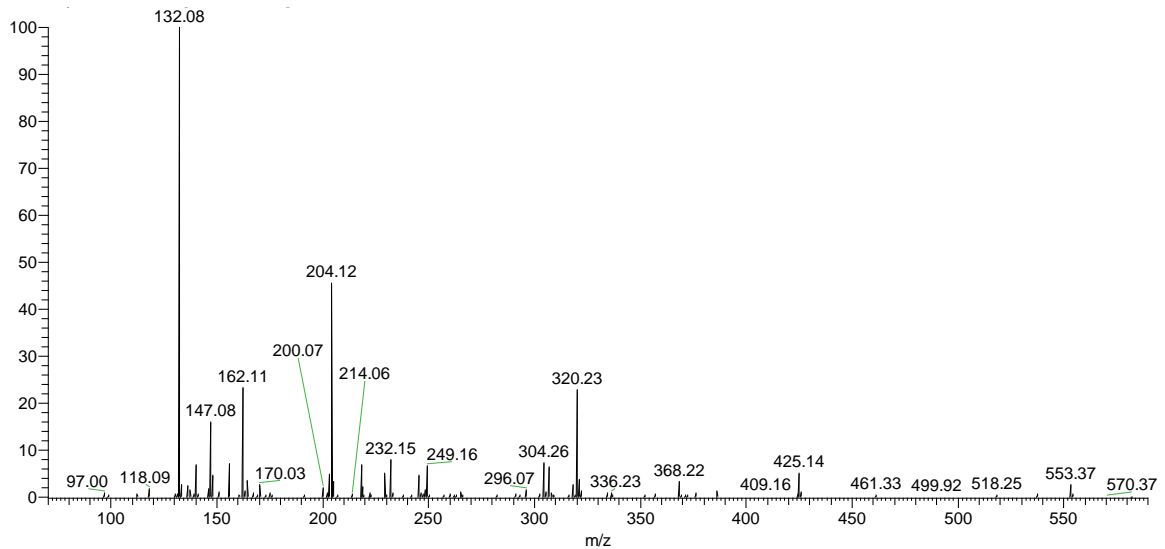

Figure 6-4: Example chromatogram from FTICR-MS assay of a sample used in the study; the relative abundance of a metabolite identified by m/z ratio is represented in the Y-axis

6.2.4 FTICR data: Statistical analysis

Potential clinical differences between DBD and DCD grafts were evaluated by testing each OLT variable, including cold ischaemia time, warm ischaemia time, hours in ITU, number of days-in hospital following OLT, peak aspartate transaminase (AST), and incidence of primary non-function. Non-parametric 2-sample Wilcoxon rank-sum tests were applied for continuous numerical variables (e.g., CIT) and Fisher's exact tests were applied for binary variables (e.g., the occurrence of primary non-function). The obtained *p* values were adjusted for multiple hypothesis testing using the Benjamini and Hochberg method to control the false discovery rate (Benjamini and Hochberg 1995).

Principal component analysis (PCA) was used to represent the multivariate FT-ICR mass spectral metabolomics data in 2-dimensional space in terms of principal components PC1 and PC2. Univariate statistical analysis, on a per peak basis, was used to discover if any metabolites differed significantly a) between donor cold phase (T_1) and recipient post-reperfusion (T_2) across all patients, and b) between DCD and DBD grafts in the cold phase and, separately, post-reperfusion. Here, the

Anderson-Darling test was used to evaluate normality assumptions, and since ca. 40% of the peaks did not follow a normal distribution, non-parametric statistical methods were used, specifically a two-sample Wilcoxon rank-sum test and for its extension to more groups, Kruskal-Wallis one-way analysis of variance, both with a Benjamini and Hochberg false discovery correction. In addition, gain scores analysis (Kruskal-Wallis on gain scores) was used to discover those metabolites that changed in a significantly different manner from cold-phase to post-reperfusion between the DCD and DBD grafts. All statistical analyses were carried out using R version 3.0.2, a free programming language and software for statistical computing and graphics.

6.2.5 Putative assignment of metabolites

KEGG database contain very large number of genes and protein sequences, and is an online resource which allows pathway mapping and identification of individual metabolites that not only associated with humans, but also those from various other biological cellular systems, as well as environmental pathways and pharmaceutical compounds (<http://www.genome.jp/kegg/pathway.html>). The aim of this database is to make functional and evolutionary hypothesis about genes or molecules that researchers are interested. This database has been pioneered as a key resource for scientists investigating complex large-scale bioinformatics molecular datasets such as those generated by genomics, transcriptomics, proteomics, and metabolomics (Kanehisa 2002). The database assists with pathway mapping of a large number of biological systems, allows biological interpretation of higher-level systemic functions. Initiated in 1995 under the human genome program of Ministry of education in Japan, foreseeing the need for a computerised database this allowed the interpretation of metabolic pathways (Kanehisa & Goto 2000). KEGG database is comprised of large collection of manually drawn pathway maps representing experimental knowledge on metabolism and various other functions of the cell and the organism. The database originally consisted of pathways drawn in three broad categories; genomes, pathways and ligand; however these were later expanded in many other pathways(Kanehisa et al. 2006;Kanehisa & Goto 2000). Most of the metabolomics studies are referenced to the pathways and ligand maps through a

“top-down” approach(Kanehisa 2002). With the advent of new experiments involving the cellular systems these pathways are continuously amended and extended. Each pathway map contains a large network of molecular interactions and reactions and these pathways are designed to link genes in the genome to gene products (mostly proteins) in the pathway (Kanehisa et al. 2008).

In our studies of FTICR based metabolomic study outlined in this chapter, the putative assignment of metabolites was carried out with reference to the KEGG database against the mass/charge ratio of each identified molecule, similar to the methods described in our initial proof-of principle study (Hrydziuszko, Silva, PR Perera, Richards, Murphy, Mirza, & Viant 2010b). One of the limitations of identification of molecules detected by FTICR technique however, is difficulty of computer based automated identification of molecules. This limitation is originating from the high resolution power of the mass spectrometer, as a particular molecule with a particular mass may be assigned to different empirical formulae resulting in high false positive rates. School of Biosciences at the University of Birmingham uses an approach called transformation mapping (TM) which increases the accuracy of identification of metabolites (Weber and Viant 2010).

6.3 Patients and graft characteristics

The liver transplantation procedures were carried out in a similar manner for DBD and DCD grafts and we did not notice any significant differences either at the procedure level or the short-term outcomes. The mean CIT was 484.52 ± 143.59 (DBD) and 461.00 ± 116.97 (DCD), whereas the mean implantation time, when grafts were exposed to further warm ischaemia until the circulation was restored, was 41.85 ± 6.94 (DBD) and 41.80 ± 9.77 (DCD). The recipients spent on average 95.04 ± 120.80 (DBD) and 123.22 ± 174.48 (DCD) hours in the intensive care unit. Table 6-1 depicts the basic demographics of the study population. The majority of transplants were successful; three patients in the entire study group had peri-operative mortality (n=2 in the DBD group). The causes of death were related to initial poor

function/primary non-function in two patients (one patient each in DCD and DBD groups) and related to hepatic artery thrombosis in the third patient.

Table 6-1: The characteristics and basic demographics of the recipients undergoing liver transplantation.

	DCD (n=10)	DBD (n=27)
Age	53 (41-64) years	56 (26-66) years
MELD at the transplant	12 (8-22)	16 (6-22)
Indication for transplant*	ALD (3), HCV (2), HBV (1), NASH (1), PCLD (1), PBC (2)	ALD (11), HCV (5*), PCLD (2), PBC (3), PSC (3), Wilson's disease (1), Autoimmune hepatitis (1), Cryptogenic cirrhosis (1)
Donor warm ischaemia time (dWIT)	14 (12-28)minutes	N/A
CIT before the T ₁ biopsy	263 (93-403) min	236 (53-534) minutes
Total CIT	493 (256-651) min	467 (287-817) minutes
Implantation time of the graft	40 (32-65) min	40 (31-59) minutes
Graft macrosteatosis on T ₁	None (1), Mild (6), Severe (3)	None (2), Mild (19), Moderate (3), Severe (3)
Graft microsteatosis on T ₁	None (2), Mild (8)	None (4), Mild (22), Moderate (1)

Abbreviations : ALD – alcoholic liver disease, HCV – hepatitis C disease, HBV – hepatitis B disease, NASH – non-alcoholic steatohepatitis, PCLD – polycystic liver disease, PBC – primary biliary cirrhosis, PSC- primary sclerosing cholangitis; * patients diagnosed with hepatocellular carcinoma (n=3 and 4 in DCD and DBD groups respectively); N/A – donor warm ischaemia time not applicable to DBD donor

The few cases of initial poor function and ischaemic injury in this study precluded us from searching for metabolic changes that are predictive of the problematic (graft injury) or unsuccessful (primary non-function) outcomes. However, previous studies on larger cohorts ($n > 300$) of DBD and DCD liver transplantations provide evidence for the inferiority of the DCD donations, including increased incidence of primary non-function, biliary complications as well as lower graft- and patient survival (Foley et al. 2005; Monbaliu et al. 2012). Therefore, here, we focused on investigating the metabolic alterations in the DCD grafts as compared to the more traditional method of transplantation using DBD donors. Due to the lack of significant differences between the DCD and DBD procedures and outcomes in our study, all grafts within the DCD group were treated equally, as were the DBD-graft group. Any metabolic dissimilarity between these groups should therefore be reflective of the inherent molecular differences between DCD and DBD grafts.

6.4 Changes in hepatic metabolism during transplantation

FTICR mass spectra of the extracted biopsies contained 1260 reproducibly detected peaks of which 448 (35.56%) were putatively annotated based upon accurate mass measurements and the Kyoto Encyclopaedia of Genes and Genomes database. Principal component analysis verified the high technical reproducibility of the mass spectra, evidenced by the clustering of the measurements of the QC sample on the PCA scores plot (Mateo et al. 2006). Furthermore, the PCA scores showed a clear separation between the biopsies from the cold phase (CP, T_1) and post reperfusion (PR, T_2) (figure 6-5). The clustering of the donor biopsies (D, T_0 ; obtained from six DBD grafts while the organs were still perfused with warm circulation) close to the post-reperfusion biopsies (PR, T_2), with both groups having very distinctive metabolic profiles compared to the biopsies originating from the cold phase sampling is a striking result. This signifies the distinctively different metabolism of hepatocytes in the perfused state compared to those in cold storage. This metabolic separation was confirmed by univariate testing that detected 688 (54.60%) significantly different peaks between CP (T_1) and PR (T_2), 293 peaks (23.25%)

between donor (T₀) and CP (T₁) and only 124 peaks (9.84%) between CP (T₁) and PR (T₂) (Kruskal-Wallis test, $p < 0.05$). In our previous proof-of-principle study, we identified a plethora of metabolic responses in the post-reperfused grafts compared to their cold-phase state and concluded that these changes reflected the rapid resumption of the biochemical functions of hepatocytes following reperfusion, including increased urea production, bile acid synthesis and clearance of the preservation solution. Here, in addition to verifying these expected metabolic responses, we observed additional key metabolic changes including, amongst others, putatively annotated essential (threonine and valine) and non-essential (tyrosine, serine and proline) amino acids, taurine (a major constituent of bile), and kynurenine (a central compound in the tryptophan metabolism pathway) (table 6-2).

The close grouping of the donor and post-reperfusion biopsies along with their clear separation from the cold-phase biopsies (along PC1) is further supportive of the rapid resumption of the biochemical functions in the reperfused grafts and shows the direction of metabolic changes through the patient journey and the OLT procedure - from 'healthy' donor grafts through cold-phase to almost fully functional grafts shortly following reperfusion.

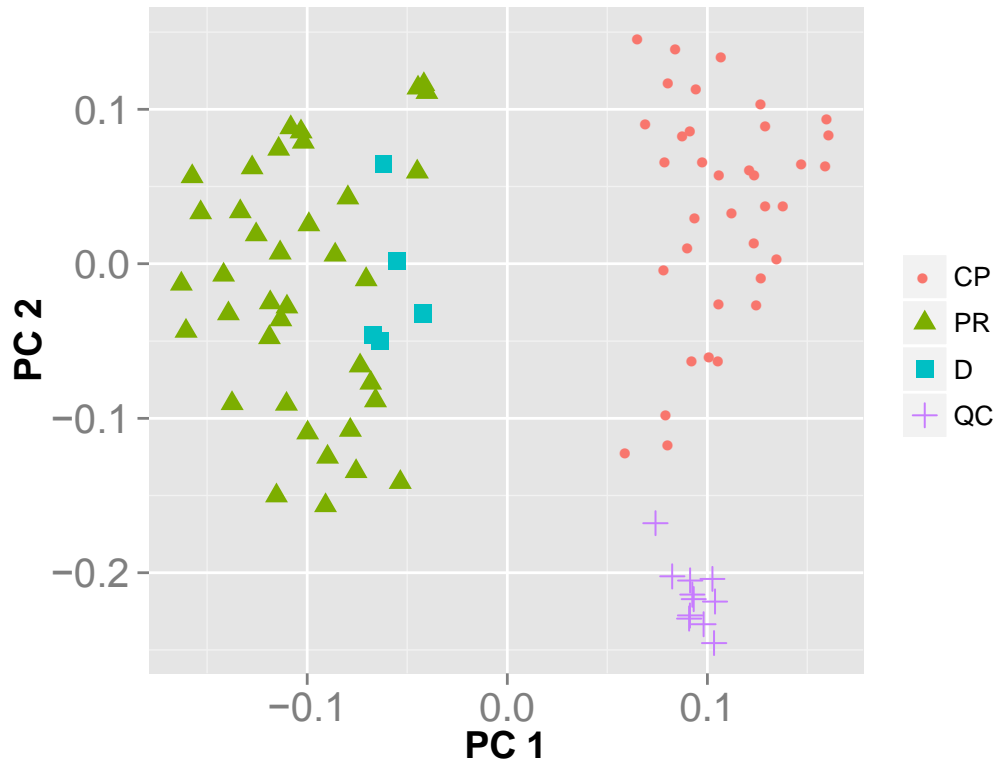

Figure 6-5: Principle component analysis scores plot showing the similarities and differences between the metabolic profiles of the grafts in donor (T_0), cold (CP, T_1) and post-reperfusion phases (PR, T_2). Donor and post-reperfusion biopsies cluster together and have distinctive metabolic profiles compared to the cold-phase biopsies, indicative of the rapid resumption of the biochemical functions in the post-reperfusion grafts in the direction of the 'healthy' donor grafts.

Table 6-2: Top putatively annotated metabolic fold-changes (FC) in the liver grafts between donor phase (D, T₀), cold phase (CP, T₁) and post-reperfusion phase (PR, T₂), considering the DBD and DCD biopsies as one group.

<i>Putative metabolite</i>	<i>m/z</i>	<i>Empirical formula</i>	<i>Ion</i>	<i>FC: PR/CP</i>	<i>FC: PR/D</i>	<i>FC: CP/D</i>	<i>Significance**</i>	<i>Univariate rank</i>	<i>PC1 rank</i>
Histidine*	178.0587	C ₆ H ₉ N ₃ O ₂	Na, H, ³⁹ K	3.88	1.43	0.37	CP vs. D; CP vs. PR	1, 117, 181	1, 130, 198
Malate	157.0107	C ₄ H ₆ O ₅	Na, 2K-H	4.61	1.64	0.36	CP vs. D; CP vs. PR	3, 259	58, 116
Glutamate*	170.0424	C ₅ H ₉ NO ₄	Na, 2Na-H	5.14	1.69	0.33	CP vs. D; CP vs. PR	13, 37	15, 20
Serine	128.0318	C ₃ H ₇ NO ₃	Na, 2Na-H, K(39),	2.95	1.77	0.60	CP vs. D; CP vs. PR	15, 19, 143,	101, 105, 111, 205
Glutamine	169.0584	C ₅ H ₁₀ N ₂ O ₃	Na, ³⁹ K, 2K-H	4.51	1.41	0.31	CP vs. D; CP vs. PR	16, 161, 233	12, 128, 172
N-Acetyl-L-glutamate	212.0530	C ₇ H ₁₁ NO ₅	Na	3.60	2.81	0.78	CP vs. PR; D vs. PR	18	30
O-Phospho-L-serine	207.9983	C ₃ H ₈ NO ₆ P	Na, H, ³⁹ K	6.14	1.37	0.22	CP vs. D; CP vs. PR	20, 84, 146	23, 56, 152
Tyrosine	204.0632	C ₉ H ₁₁ NO ₃	Na, H	3.46	1.32	0.38	CP vs. D; CP vs. PR	23, 175	25, 90
ADP*	472.0008	C ₁₀ H ₁₅ N ₅ O ₁₀ P ₂	2Na-H, Na	5.46	1.11	0.20	CP vs. D; CP vs. PR	26, 51	45, 84
CDP-choline	489.1149	C ₁₄ H ₂₆ N ₄ O ₁₁ P ₂	H	0.42	1.16	2.73	CP vs. D; CP vs. PR	49	41
Mannitol*	223.0404	C ₆ H ₁₄ O ₆	⁴¹ K	0.03	1.34	46.97	CP vs. D; CP vs. PR	61	4
Taurine	148.0039	C ₂ H ₇ NO ₃ S	Na	2.11	1.15	0.55	CP vs. D; CP vs. PR	88	109
Citrate	193.0343	C ₆ H ₈ O ₇	H	0.20	2.44	12.14	CP vs. D; CP vs. PR	97	92
Threonine	142.0474	C ₄ H ₉ NO ₃	Na	2.76	1.37	0.50	CP vs. PR	110	66
Proline	138.0525	C ₅ H ₉ NO ₂	Na, H	2.40	2.75	1.14	CP vs. PR; D vs. PR	115, 221	235, 331
GMP	386.0473	C ₁₀ H ₁₄ N ₅ O ₈ P	Na	3.03	0.98	0.32	CP vs. D; CP vs. PR	140	147
Glucose	221.0247	C ₆ H ₁₂ O ₆	⁴¹ K	0.38	0.85	2.25	CP vs. D; CP vs. PR	153	114
Glycocholate*	488.2984	C ₂₆ H ₄₃ NO ₆	Na	4.49	3.27	0.73	CP vs. PR	154	170
Succinate	141.0158	C ₄ H ₆ O ₄	Na	0.49	1.06	2.17	CP vs. D; CP vs. PR	185	106
Valine	140.0682	C ₅ H ₁₁ NO ₂	Na, ³⁹ K, H	2.63	1.44	0.55	CP vs. PR	186, 218, 253	260, 272, 281
Choline	145.0688	C ₅ H ₁₄ NO	⁴¹ K	2.01	2.73	1.36	CP vs. PR; D vs. PR	199	377
Formate	90.97661	CH ₂ O ₂	2Na-H	5.37	3.47	0.65	CP vs. PR	205	582
O-Phospho-L-	200.0320	C ₄ H ₁₀ NO ₆ P	H	2.87	1.35	0.47	CP vs. PR	209	83
Kynurenine	209.0922	C ₁₀ H ₁₂ N ₂ O ₃	H	1.78	2.76	1.55	CP vs. PR; D vs. PR	232	338
Aspartate	134.0447	C ₄ H ₇ NO ₄	H	2.56	1.17	0.46	CP vs. D; CP vs. PR	243	139
Urea*	98.99550	CH ₄ N ₂ O	³⁹ K	2.48	1.31	0.53	CP vs. PR	268	308

*metabolic changes observed, verifying those reported in our proof-of-principle study (Reich, Mulligan, Abt, Pruett, Abecassis, D'alessandro, Pomfret, Freeman, Markmann, & Hanto 2009) **corrected p-values < 0.05

6.5 Hepatic metabolism in DBD compared to DCD grafts

Despite not seeing any significant differences in the procedures or short-term outcomes for the DCD and DBD transplantations, we were able to identify a small subset of peaks that distinguished the DCD and DBD grafts at the metabolic level. In particular, we detected 50 peaks including 11 putatively annotated compounds that differed between DCD and DBD in the cold phase (CP), 64 peaks (10 putatively annotated) that differed between DCD and DBD following reperfusion (PR), and 72 peaks (10 putatively annotated) that changed from CP to PR in a significantly different manner between DCD and DBD grafts (table 6-3). The PCA scores plots, based only on these sub-selections of peaks provide a visualisation of the clear separation along PC1 for the cold-phase biopsies and almost as clear separation for the post-reperfusion biopsies (figure 6-6).

Table 6-3: Top putatively annotated metabolic fold-changes between the DCD and DBD grafts: combined results for the comparison, (i) in the cold phase (CP, T₁), (ii) following reperfusion (PR, T₂), and (iii) in response from going from CP (T₁) to PR (T₂)

<i>Putative metabolite</i>	<i>M/Z</i>	<i>Empirical formula</i>	<i>Ion</i>	<i>Fold-change DCD/DBD¹</i>	<i>Univariate Rank²</i>
Tryptophan	205.0972	C ₁₁ H ₁₂ N ₂ O ₂	H	1.88 ^{CP} , 1.10 ^{PR}	3 ^{CP} , 28 ^G
Adenylosuccinate	464.0815	C ₁₄ H ₁₈ N ₅ O ₁₁ P	H	0.40 ^{CP}	6 ^{CP}
GMP	402.0212	C ₁₀ H ₁₄ N ₅ O ₈ P	³⁹ K	0.47 ^{CP}	15 ^{CP}
Malate	210.9406	C ₄ H ₆ O ₅	2K-H	0.44 ^{CP}	18 ^{CP}
ADP	465.9928	C ₁₀ H ₁₅ N ₅ O ₁₀ P ₂	³⁹ K	0.41 ^{CP}	20 ^{CP}
D-Glucose	203.0526	C ₆ H ₁₂ O ₆	Na	1.72 ^{CP} , 1.22 ^{PR}	22 ^{CP} , 9 ^G
ADP	450.0189	C ₁₀ H ₁₅ N ₅ O ₁₀ P ₂	Na	0.53 ^{CP}	25 ^{CP}
O-Acetyl-L-carnitine	204.1230	C ₉ H ₁₈ NO ₄	-e	0.45 ^{CP}	28 ^{CP}
Kynurenine	209.0922	C ₁₀ H ₁₂ N ₂ O ₃	H	1.80 ^{CP}	43 ^{CP}
Leucine	132.1019	C ₆ H ₁₃ NO ₂	H	1.49 ^{CP}	47 ^{CP}
Pantothenate	220.1180	C ₉ H ₁₇ NO ₅	H	0.60 ^{CP}	49 ^{CP}
Glutathione	352.0549	C ₁₀ H ₁₇ N ₃ O ₆ S	2Na-	1.13 ^{CP} , 1.88 ^{PR}	3 ^{PR} , 38 ^G
Threonine	142.0474	C ₄ H ₉ NO ₃	Na	1.37 ^{CP} , 2.07 ^{PR}	4 ^{PR} , 70 ^G
Leucine	154.0838	C ₆ H ₁₃ NO ₂	Na	1.37 ^{PR}	16 ^{PR}
Glutamate	170.0424	C ₅ H ₉ NO ₄	Na	0.99 ^{CP} , 1.61 ^{PR}	25 ^{PR} , 72 ^G
Creatine	154.0587	C ₄ H ₉ N ₃ O ₂	Na	1.45 ^{PR}	32 ^{PR}
Glutamate	192.0244	C ₅ H ₉ NO ₄	2Na-	1.01 ^{CP} , 2.78 ^{PR}	38 ^{PR} , 45 ^G
Threonine	120.0655	C ₄ H ₉ NO ₃	H	1.37 ^{PR}	41 ^{PR}
Proline	138.0525	C ₅ H ₉ NO ₂	Na	1.59 ^{PR}	53 ^{PR}
Pantothenate	220.1180	C ₉ H ₁₇ NO ₅	H	0.79 ^{PR}	62 ^{PR}
Leucine	132.1019	C ₆ H ₁₃ NO ₂	H	1.32 ^{PR}	64 ^{PR}
Ornithine	133.0971	C ₅ H ₁₂ N ₂ O ₂	H	1.98 ^{CP} , 1.05 ^{PR}	42 ^G
Serine	150.0137	C ₃ H ₇ NO ₃	2Na-	0.78 ^{CP} , 3.01 ^{PR}	54 ^G
SAM	399.1446	C ₁₅ H ₂₂ N ₆ O ₅ S	H	1.23 ^{CP} , 0.68 ^{PR}	51 ^G
Glucose	221.0247	C ₆ H ₁₂ O ₆	⁴¹ K	1.40 ^{CP} , 1.05 ^{PR}	59 ^G

¹ Fold-change calculated for the corresponding phase, cold phase (CP) or post reperfusion (PR)

² Ranking carried out separately for the three comparisons: in the cold phase (CP), post-reperfusion (PR) or based on the Gain Scores Analysis (G): capturing the metabolic responses between DCD and DBD grafts from the CP to PR

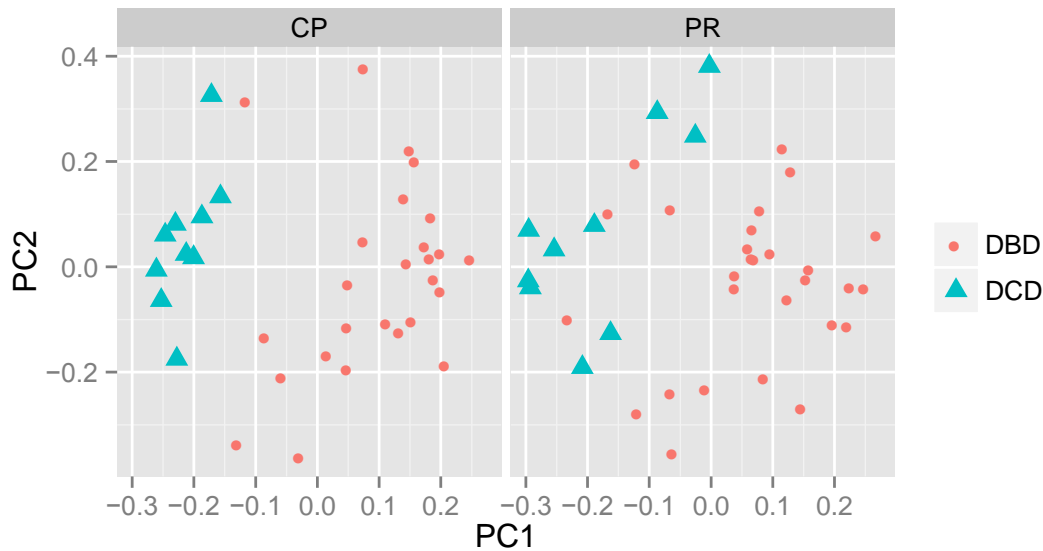

Figure 6-6: Principle component analysis scores plots highlighting the metabolic separation of the DBD and DCD grafts in the cold phase (CP) and separately the post-reperfusion phase (PR), based on analyses of just the 50 and 64 peaks identified as being significantly different (between DBD and DCD) for the CP and PR groups, respectively.

The metabolic differences between DBD and DCD grafts in the cold phase (CP, T₁) included increased levels (in DCD) of the putatively annotated metabolites tryptophan, kynurenine, glucose and leucine and decreased levels of adenylosuccinate, GMP, ADP, malate, O-acetyl carnitine and pantothenate (table 6-4). The observed putative metabolites are involved mainly in tryptophan metabolism, purine metabolism, oxidative phosphorylation and a set of carbohydrate metabolic pathways, including the TCA cycle, pyruvate metabolism, glycolysis/gluconeogenesis and the pentose phosphate pathway (Perera et al. 2014b). Among these findings, tryptophan and its metabolism have received earlier attention in the liver transplantation field. Tryptophan is an essential amino acid that, amongst other roles, serves as a precursor of neurotransmitter serotonin and B₃ vitamin. Histidine-tryptophan-ketoglutarate (HTK) solution, which contains tryptophan to prevent

membrane injury, was proposed as an alternative liver preservation solution to the gold standard, University of Wisconsin solution. The systematic review to compare the efficacy and safety of these two solutions did not show overall significant differences, yet in some cases HTK was believed to perform better, especially in terms of biliary tract flush and prevention of biliary complications (Feng et al. 2007). Furthermore, tryptophan can be catabolised either via the kynurenine or serotonin pathways, and hence kynurenine was studied previously to investigate tryptophan metabolism in potential cirrhotic liver transplant recipients. The pre-transplant serum levels of kynurenine as well as the kynurenine/tryptophan ratios were positively correlated with the disease severity, while serum levels of tryptophan and serotonin showed no correlation (Rossouw et al. 1977). The significantly higher levels of tryptophan and kynurenine in DCD grafts during the cold phase in our study appears to support the previous studies that identified tryptophan metabolism via kynurenine pathways as a key metabolic changes in liver transplantation(Knox 1951).

Table 6-4: Metabolic pathways discovered to differ significantly between DCD and DBD grafts, including the associated putatively annotated metabolites in those pathways.

<i>Metabolic pathway</i>	<i>Putative metabolite</i>	<i>Description¹</i>
Tryptophan metabolism	Tryptophan, Kynurenine	Amino acid metabolism; CP ^H
Purine metabolism	Adenylosuccinate, GMP, ADP	Nucleotide metabolism; CP ^L
Oxidative phosphorylation	ADP	Energy metabolism; CP ^L
TCA cycle	Malate	Carbohydrate metabolism; CP ^L
Pyruvate metabolism	Malate	Carbohydrate metabolism; CP ^L
Glycolysis / Gluconeogenesis	Glucose	Carbohydrate metabolism; CP ^H
Pentose phosphate pathway	Glucose	Carbohydrate metabolism; CP ^H
Alanine, aspartate and glutamate metabolism	Adenylosuccinate, Glutamate	Amino acid metabolism; CP ^L , PR ^H
Glycine, serine and threonine metabolism	Tryptophan, Threonine, Creatine, Serine	Amino acid metabolism; CP ^H , PR ^H
Cysteine and methionine metabolism	Glutathione, Serine, SAM	Amino acid metabolism; PR ^H with exception of lower levels of SAM
Arginine and proline metabolism	Glutamate, Creatine, Proline, Ornithine, SAM	Amino acid metabolism; PR ^H with exception of lower levels of SAM
Valine, leucine and isoleucine degradation & biosynthesis	Leucine, Threonine	Amino acid metabolism; CP ^H , PR ^H
Glutathione metabolism	Glutathione, Glutamate, Ornithine	Metabolism of other amino acids; PR ^H
Taurine and hypotaurine metabolism	Glutamate	Metabolism of other amino acids; PR ^H
D-Glutamine and D-glutamate metabolism	Glutamate	Metabolism of other amino acids; PR ^H
Aminoacyl-tRNA biosynthesis	Tryptophan, Leucine, Threonine, Glutamate, Proline, Serine	Translation; CP ^H , PR ^H
ABC transporters	Glucose, Leucine, Glutathione, Glutamate, Proline, Ornithine, Serine	Membrane transport; CP ^H , PR ^H
Pantothenate and CoA biosynthesis	Pantothenate	Metabolism of cofactors and vitamins; CP ^L , PR ^L
Vitamin digestion and absorption	Pantothenate	Digestive system; CP ^L , PR ^L
Bile secretion	Glucose, Glutathione	Digestive system; CP ^H , PR ^H

¹, H, higher levels and L, lower levels of putative metabolites in DCD in the corresponding OLT stage (CP, T1 or PR, T2)

Although it was not our key objective to analyse biomarkers related to primary non-function in the present study given smaller sample size, the two failed allografts due to primary non-function had abundantly higher levels of tryptophan and kynurenine (figure 6-7).

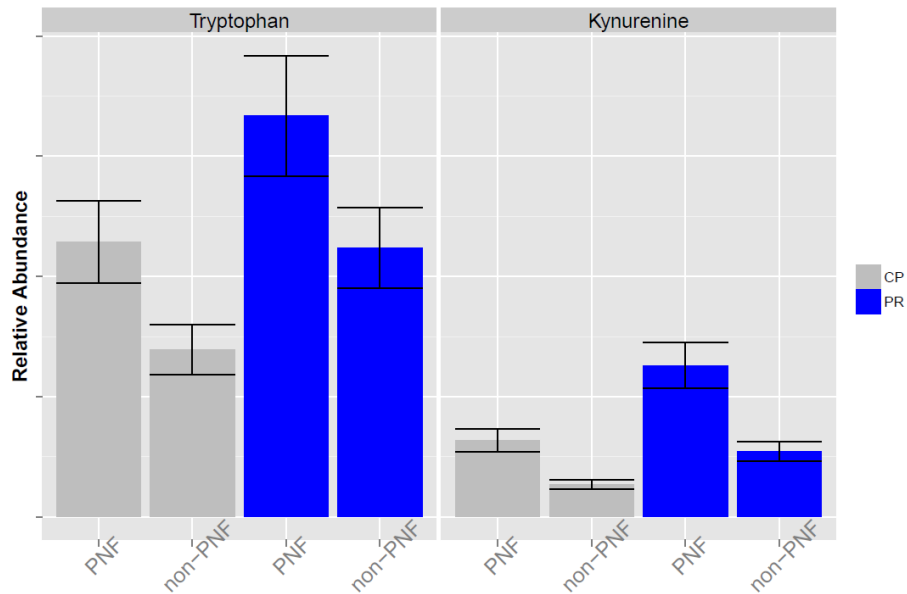

Figure 6-7: The differences between tryptophan and kynurenine in failed allografts due to primary non-function (n=2) vs. other allografts (n=36) in the cold phase (grey) and post reperfusion (blue). The data show the relative abundances of the metabolites with 95% confidence intervals (statistics not applied due to limited sample size)

The putatively annotated metabolites that significantly differed between DCD and DBD grafts following reperfusion (PR) included increased levels (in DCD) of glutathione, threonine, leucine, glutamate, creatine, glutamate, proline and decreased levels of pantothenate. In addition, four of these metabolites including glutathione, threonine, glutamate and glutamate were changed in a significantly different manner in DCD and DBD grafts while they were removed from cold storage (CP, T₁) and following reperfusion (PR, T₂). The remaining six metabolites identified as different in the Gain Scores Analyses included tryptophan and glucose (previously observed as significantly different in the cold-phase) as well as ornithine, serine, S-adenosyl methionine (SAM) and glucose. All of these putatively annotated metabolites are primarily involved in amino acid metabolism and translation (aminoacyl-tRNA biosynthesis) and to a lesser extent in metabolism of cofactors and vitamins and bile secretion. The significant increase in SAM during post-reperfusion, in DCD grafts

relative to DBD grafts, could have implications for DNA methylation given the importance of this metabolite as a methyl donor (Mato and Lu 2007).

The increased level of glutathione in DCD grafts, following reperfusion, is also an intriguing finding. Glutathione, owing its thiol group, is known as one of the most effective antioxidants preventing cellular damage caused by reactive oxygen species, as occur in ischaemia/reperfusion injury. Its precursors, acetylcysteine, has been studied as a protective molecule in the peri-operative treatment of patients undergoing liver transplantation (Clavien et al. 2007). Our findings show that not only were glutathione levels increased but so were other intermediates of glutathione metabolism such as glutamate and ornithine, indicative of disruption to the glutathione pathway. While glutathione and glutamate shared similar responses at the post-reperfusion time point, i.e. a rapid increase of levels in DCD compared to DBD, ornithine levels were higher in the cold-phase and similar following reperfusion. This could be due to ornithine being used up for the biosynthesis of glutathione via the intermediate by-product of glutamate.

6.6 Discussion

Our dataset has for the first time identified key metabolic differences between DCD and DBD liver grafts, which we attribute to the hallmark differences of organ donation in these two donor types. Some of the identified biomarkers correlate with our current understanding of the physiological changes surrounding DCD organ donation, including an impact on glucose metabolism by donor warm ischaemia in DCD grafts. However, our observed changes to the tryptophan/kynurenine axis in the DCD grafts are novel findings (Smyth 2004). Both of these metabolites were observed at ca. 2-fold higher concentration in the DCD grafts in the cold phase, suggesting the possibility that these metabolites are responsible for, or at least could be indicators of, the reported higher incidences of increased graft failures in DCD

grafts in the literature. Given the role of metabolomics as a hypothesis generating tool, and not to determine whether this metabolic pathway is indeed the cause of graft failure, we conclude that subsequent clinical investigations of DCD versus DBD transplantations should employ a targeted analytical approach to robustly quantify the metabolites in the tryptophan/kynurenine pathway in the pursuit of more reliable biomarkers of graft function.

CHAPTER 7 CONCLUDING REMARKS AND FUTURE WORK

*Interpretation of the work outlined in previous chapters led the researcher presenting this thesis to conceptualise novel theories on energy metabolism and graft function, which was studied in the clinical research setting leading to the publication annexed as Appendix 4; **Liver Int. 2014. doi: 10.1111/liv.12706.***

This thesis outlines four studies performed in the setting of adult cadaveric liver transplantation, aimed at identifying biomarkers and the evaluated different biomaterial sampling protocols combined with more sophisticated analytical platforms. Whilst the proof of principle concept outlined in chapter 3 provided us with the necessary confidence to carry out more exhaustive and time consuming wider study comparing the DCD and DBD liver grafts. Through the three main studies outlined in chapters 4-6 we have demonstrated the primary differences between these two types of donor liver allografts, and possible identification of biomarkers that fulfil the objectives set out at the beginning of this thesis. Findings of these studies give an in depth idea of how the metabolome of hepatocytes work during the process of transplantation, and I have identified few key pathways that require further study and proposed outline of future work.

7.1 Graft function and energy metabolism

All cellular systems are reliant on energy sources that drive metabolic processes for survival. In humans, and in almost all other animals, the primary source of energy is glucose or other forms of carbohydrate. Oxidative phosphorylation and ATP generation are the keys to sustain vital functions of the human body. Constant oxygen delivery to the tissues and supply of glucose is maintained in the living state, but this process is temporarily halted on the transplantable solid organ once it is retrieved from the donor. Although organ preservation is aimed at minimising

intracellular metabolism this occurs at a slow pace compared with the perfused state, and the energy for the continued metabolism is originating from conversion of intracellular energy stores. Stored intracellular energy is present in most cellular types in the form of glycogen, although some of the tissue cells, for example neurons in brain do not store intracellular glycogen making these more susceptible for permanent and irreversible damage in the absence of constant energy supply (Brown and Ransom 2007). Glycogen in the liver plays a key role in maintaining not only the intra-hepatocytic energy demand but also the glucose homeostasis of the entire body. In the fed state abundant glucose is converted to glycogen in the liver for the use in future, fasted states that result in hypoglycaemia (Newsholme and Leech 1983). The role of intracellular glycogen in the setting of liver transplantation has been studied in the somewhat early era of liver transplantation, but not in the context of marginal donor or DCD graft setting (Cywes et al. 1992; Kukan and Haddad 2001). Meanwhile some other studies compared glycogen depletion in the liver allografts preserved using different organ preservation solutions to claim superior preservation in the presence of less glycogen depletion of the allografts (Fratte et al. 1991). It is well known that reperfusion causes a hypermetabolic state in the liver due to activated Kupffer cells, thus increasing the demand for energy (Schemmer et al. 2001). Therefore the role of glycogen as a primary energy source is pivotal in maintaining intracellular energy and cell integrity, and should not be underestimated.

Our study on energy metabolism suggested that those grafts from the DCD donors, and the failed allografts were more likely to have moderate to severe glycogen depletion, and evidence of continued anaerobic metabolism leading to high intracellular lactate. As discussed under the relevant chapter these changes are the likely result of continued anaerobic metabolism in the agonal state of organ donation. This finding opens up more avenues for research involving marginal donors, not only those from DCD donors, but also grafts with fatty change as outlined below.

7.1.1 Re-charging the energy status of liver grafts as an option for successful liver transplantation

The last decade has seen dramatic changes in the field of solid organ transplantation, and the concept of machine perfusion has been extensively researched using different solid organs as the investigative front. Significant advances have been made in the normothermic organ preservation techniques involving liver grafts. Normothermic liver preservation has been studied both in the animal and human liver in the laboratory setting, and currently some of these techniques are incorporated in the clinical trials. From a theoretical point of view, normothermia alleviates or mitigates cold ischaemia related damage, and continued oxygenated perfusion provides an opportunity to feed the liver grafts with nutritional necessary to replenish depleted intracellular energy stores. The Birmingham liver unit has contributed significantly to some of the national trials involving continuous normothermic preservation currently underway, and also piloted some of the innovative techniques involving normothermic organ preservation. In the sequence of organ donation to transplantation, normothermia could be applied in different phases aiming at better organ preservation.

In DCD donors, in-situ organ resuscitation after cessation of circulatory function has been described. The original application of this technique was in category II DCD donors, who had sustained much longer periods of circulatory death and the early results, though not hugely promising, showed acceptable degree of organ recovery and successful transplantation carefully selected cases. Now termed “normothermic regional perfusion”, this technique was pioneered in the Birmingham Liver unit alongside two other centres. The rationale to use this technique in the United Kingdom where category III DCD donation is the existing practice, is that the organs could be revived and immediately after the circulatory death whilst organs are still within the body cavity of the donor, allowing maximum energy re-charge of the liver grafts for a pre-defined period prior to the commencement of cold preservation. Continuous normothermic preservation has by far has made the biggest advance. In

this technique the organs are retrieved from the donor and transported in the mechanically perfused state until the organ is transplanted in the recipient. Apart from two brief periods of cold flush on either side of machine perfusion, this technique maintains normothermic state throughout the organ is out of a human body, this could be considered the best form of organ preservation from a biological stand point. Final application of normothermia comes from a form of resuscitation at the end of cold storage, compared to the two earlier described methods of pre-cold storage and continues normothermic preservation techniques. Although research has proved this is a viable option no clinical studies has been carried out so far. The Birmingham liver unit however successfully transplanted the first liver graft adopting such technique.

Our current understanding provides a platform to study the liver grafts for changes of energy metabolism during normothermic and cold storage. The cornerstone of ischaemia reperfusion injury has been attributed to the cold storage and ATP depletion (St Peter et al. 2002), reversal of energy imbalance by normothermic preservation by application of any of the above three techniques, either in isolation or in combination would provided added insights into the superiority of normothermia over hypothermia.

7.1.2 Insulin, insulin like growth factor-I (IGF-I) and liver

The influx of glucose in to the hepatocytes is dependent of the actions of insulin. The role of insulin in liver transplantation is well established from the pioneering days of this life saving operative procedure. It has been identified that the portal blood flow, which carries insulin secreted by the pancreas is pivotal for the survival of the transplanted liver graft. This is well documented by the experimental transplantation in the bygone era where heterotrophic transplanted liver grafts failed to survive, whilst establishment of portal inflow to the graft enabled survival. This was termed the “hepatotropic” effects of the hormone insulin (Starzl et al. 1976). An important

notion which may be less established in our general thinking about both liver disease, diabetes and insulin resistance as well as in the field of liver transplantation is the central role of liver in the control over the actions of insulin and in regulation of glucose metabolism. While pancreatic islet dysfunction and peripheral insulin resistance are commonly recognized causes for diabetes and impaired glucose tolerance, 'hepatogenous' diabetes has drawn less attention (Picardi et al. 2006). Evidence suggests 7-15% of cirrhotic patients have overt diabetes, and another 60-80% have impaired glucose tolerance.

The liver ensures glycogen storage in anabolic states and glycogenolysis and gluconeogenesis in catabolic states. But several other ways in which the liver controls body-wide glucose homeostasis are described, such as insulin clearance from the portal circulation by the liver, hepatic insulin resistance and sensitivity, and feedback mechanisms in growth hormone (GH) and insulin-like growth factor-1 (IGF-1) signaling. These mechanisms have likewise been related to the occurrence of diabetes and impaired glucose tolerance in liver disease. In portal hypertension or portosystemic shunts the first-pass effect of the liver to clear insulin from the circulation is reduced. The subsequent hyperinsulinaemia evokes an adaptive response of compensatory insulin resistance, presumably by down regulation of insulin receptor expression (Picardi, D'Avola, Gentilucci, Galati, Fiori, Spataro, & Afeltra 2006). An acquired GH-resistance has been described in chronic liver diseases, with reduced levels of IGF-1 (Sumida et al. 2014). Liver-specific deletion of the GH receptor in mouse models leads to insulin resistance, glucose intolerance, increased free fatty acids and steatosis. In chronic liver disease, these modulations of the GH, IGF-1 and insulin occur next to direct effects of liver disease on pancreatic islet cell dysfunction and increased peripheral insulin resistance (figure 7-1).

Insulin-like growth factor-1 (IGF-1) and its receptor IGF-1R are signal transducing elements in one of the most crucial cellular pathways in life. In conjunction with insulin and growth hormone (GH), they regulate protein synthesis, glucose metabolism, cellular proliferation and differentiation which are fundamental to both

metabolism and cell survival. GH, insulin and IGF-1, jointly referred to as the 'somatotrophic axis', may play a pivotal role in mechanisms of cell survival in liver transplantation, as well as in metabolic changes that occur following liver transplantation.

IGF-1 and IGF-1R are different from most other growth factors with tyrosine kinase receptors regarding some structural features, receptor-ligand interaction and downstream signaling. While most growth factors with tyrosine kinase receptors, such as epidermal growth factor, are mainly involved in autocrine and paracrine cell-to-cell signaling, IGF-1/IGF-1R signaling is also under significant endocrine control.

Chronic liver disease; combinations of:

- Decreased insulin clearance in portal hypertension or portosystemic shunt → hyperinsulinaemia → compensatory peripheral insulin resistance → preserved glucose homeostasis
- Acquired GH resistance → low levels of IGF-1, high levels of IGFBP-1 and GH. "Anti-insulin" effects of GH: insulin resistance, glucose intolerance, increased lipolysis and FFA, increased steatosis.
- Direct effects: decreased pancreatic islet function, increased peripheral insulin resistance

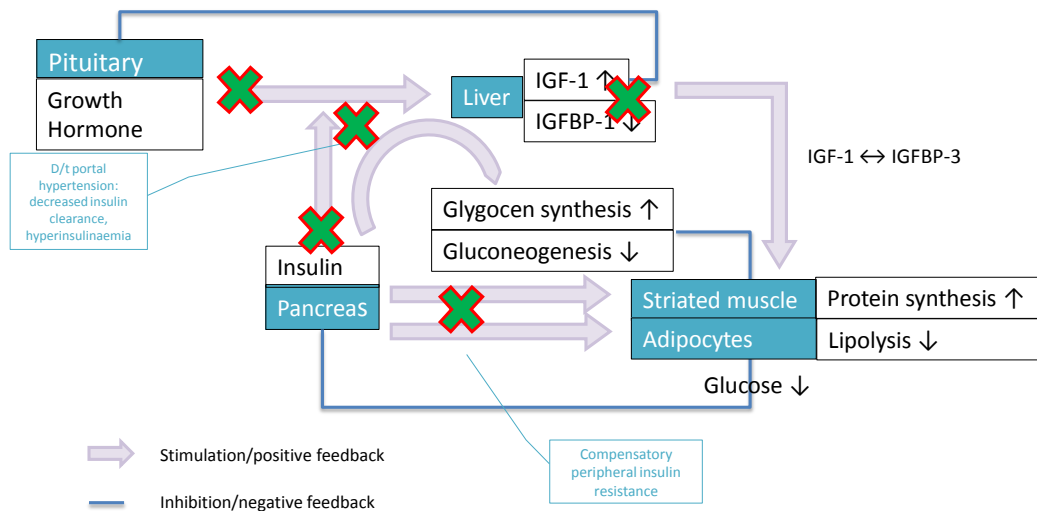

7-1: the mechanisms of actions of hormones insulin, insulin like growth factor-I (IGF-I) and IGF binding protein (IGFBP)

IGF-1R activation by IGF-1 effectuates the growth stimulating effects of growth hormone (GH) in the target organs. Ninety percent of circulating IGF-1 is produced by the liver under endocrine GH control. Moreover, IGF-1R signaling is intimately

connected to the metabolic functions of insulin. Originating from a putative same ancestor gene, the IGF-1R has specialized more in cell growth, survival and anabolic functions, whereas the insulin receptor (IR) merely regulates metabolism, but these receptors share a very similar molecular architecture and physiologically they still have functional overlap.

Specialized functions of IGF-1R and IR are regulated by structural homogeneity, diverging affinities and regulatory IGF binding proteins (IGFBP-1,2,3,4,5,6) within in a ligand-activated receptor-signaling system. IGF-1 may exert its effects via insulin receptors or hybrid insulin/IGF-1 receptors as well, although by with lower affinity. IGF-1 is recognized as an insulin sensitizer at the liver, while IGFBP-3 is suggested to oppose or inhibit IGF actions. Contrary to the high production of IGF-1, hepatocytes express low levels of the IGF-1R. Over-expression of IGF-1R however has been described in chronic hepatitis and liver cirrhosis. The autocrine and paracrine functions of IGF-1 have extensively been studied in cancer models and show that IGF-1 signaling through IGF-1R gives strong proliferation and survival signals. In models of biliary damage (through biliary obstruction or ischaemia), up regulation with anti-apoptotic and attenuating effects of IGF-1R and IGF-1 have been described (Munshi et al. 2011;Onori et al. 2007). In GH-deficient models, liver regeneration is impaired and both GH and IGF-1 are believed to protect against liver steatosis and fatty liver disease. Improved preservation has been shown by adding IGF-1 to UW perfusion solution during liver harvesting and preservation for transplantation (Zaouali et al. 2010). One study however, describes the complete opposite: a contrary involvement of the IGF-1R in conferring oxidative stress leading to hepatic cell death and promoting fibrosis in an in vivo liver-specific IGF-1R knock-out model with cholestatic liver injury (Villeneuve et al. 2010). Several cohort studies have shown early normalization of IGF-1, IGFBPs and GH levels after liver transplantation for chronic liver disease (Bassanello et al. 2004;Weber et al. 2002). No associations of these parameters with glucose intolerance or diabetes in liver transplantation have been reported up till now.

7.1.3 Insulin resistance and liver transplantation

In clinical practice of our busy transplant unit we have detected the higher incidence of new onset diabetes after transplantation (NODAT) in DCD liver graft recipients (Hartog et al. 2014). NODAT occurs in 25-40% of liver transplant recipients and the key risk factors for NODAT in liver transplant recipients are similar to standard risk factors for type 2 diabetes and insulin resistance, such as older age, African-American race, obesity and HCV infection (Kuo et al. 2010)(Zhao et al, Kuo et al). Use of steroids and calcineurin inhibitors further increase the risk (Heisel et al. 2004;Yates et al. 2012). Furthermore donor factors such as donor age (elderly donors), donor diabetes status and use of deceased vs. living donors have likewise been linked to higher incidence of NODAT (Kuo, Sampaio, Ye, Reddy, Martin, & Bunnapradist 2010;Yang et al. 2011). Whilst recent developments in liver transplantation include a steep increase in the use of organs donated after circulatory death as practiced by our centre, well-documented adverse outcomes of DCD grafts include primary non-function or delayed graft function, ischaemic type biliary lesions and increased incidence of renal injury as outlined in the introductory chapters (Callaghan et al. 2013;de Vera et al. 2009;Leithead et al. 2012).

The incidence of NODAT in liver transplant recipients of DCD grafts however, has not been studied before. The findings in our clinical research, combined with the basic science study outlined in the chapter 4 of this thesis led us hypothesize that the insulin resistance is related to the liver graft function following liver transplantation. We propose the NODAT is a subtle form of graft dysfunction increasingly seen in DCD liver graft recipients, leading to transient changes in the glucose metabolism that result in hyperglycaemia in the post transplant period. This may be driven by aggravated insulin resistance during the warm ischaemic damage during the organ donation process. One or several signaling mechanisms may be involved. Meanwhile in the case of primary non-function leading to graft failures, the insulin resistance is more likely to be more serious and irreversible. If the hepatocytes have consumed intracellular glycogen during the cold storage the cells would be in a state where complete energy discharge occurred and the hepatocytes unable to uptake glucose in

to the intracellular environment from the recipient circulation due to the presence of severe insulin resistance. Based on this hypothesis we have already commence on preliminary studies of identifying the receptor status of various types of liver grafts, and this theory is open for investigation in the machine perfusion models.

7.1.4 Energy metabolism and Insulin resistance could be the cause of graft failure in steatotic grafts

A further concept conceived from the findings from our results related to the energy metabolism is the cause for unsuccessful outcomes in fatty liver grafts. In the studies outlined here, the presence of macrovesicular steatosis was minimal, and may have perhaps occurred by chance, as the recipients consented for the study did not receive a steatotic graft. Therefore definitive links to energy metabolism cannot be made, however based on the current scientific evidence it could be extrapolated that increased graft failures from fatty liver grafts may be related to the changes in energy metabolism and insulin resistance.

We have discussed in the introduction chapter that macrovesicular steatosis is more abundant in the obese donor population, and has more relevance in the liver transplantation setting compared with microvesicular steatosis that is more acute phenomenon with less significance. Obesity is associated with both hepatic and peripheral insulin resistance (Greenfield and Campbell 2004; Marchesini et al. 1999) and extensive studies have been carried out in this front. This leads to myriad of clinical problems collectively termed as metabolic syndrome (Kanda et al. 2006). Therefore it is more likely that the steatotic liver grafts are originating from donors with metabolic syndrome, thus there is presence of insulin resistance in these liver grafts (Clark 2006; Urena et al. 1998; Williams et al. 2011). Some of these donors may have progressed to the full spectrum of fatty liver disease, commonly referred to as non-alcoholic steatohepatitis (NASH), and the pathophysiological changes are described as a “two hit theory” (Burke and Lucey 2004), originating with insulin resistance. Macroscopically therefore these grafts do not appear irreversibly

damaged apart from the presence of steatosis thus may be used in the transplantation setting (Cheng et al. 2001).

It is widely known that the steatotic livers do not tolerate longer cold ischaemia (Strasberg, Howard, Molmenti, & Hertl 1994) and successful outcomes may be achieved through transplantation by minimizing the cold storage time (Yoo et al. 2003). It is therefore likely that the increased ischaemia causes the intracellular glycogen stores depletion in steatosis liver grafts, and the insulin resistance present in the donor steatotic liver graft further prevent the influx of glucose in to the hepatocytes. These two aspects could be further studied in both experimental and clinical model. Our hypothesis is supported by the evidence that steatotic liver grafts are better preserved by normothermic machine preservation (Imber, St Peter, Handa, & Friend 2002; Jamieson et al. 2011; Vogel et al. 2010). Based on the concepts outlined in sections 7.1.3 and 7.1.4 in this chapter we have already initiated preliminary studies to investigate insulin receptor axis in the liver transplantation model.

7.2 Biomarkers of poor graft function

The metabolomics studies described in this thesis under chapters 5 and 6 outlined the use of CEAD and FTICR based analysis of two different biomaterials from liver allografts. Amongst the thousands of metabolites identified through these two studies two metabolites, namely tryptophan and kynurenine have the potential to be developed as biomarkers associated with severe graft injury. This conclusion is arrived on the basis that tryptophan metabolism pathway was identified as an affected pathway in our proof of principle study and also the both CEAD and FTICR data confirming the increased presence of these metabolites in the DCD grafts which were exposed to more ischaemic injury, along with even higher expression in the failed liver allografts. The problem we are faced now is – if tryptophan and/or

kynurenine could be studied as novel and alternative biomarkers to conventionally practiced liver enzymes to predict graft function.

Tryptophan is an essential amino acid that has unique biological and metabolic properties in the central nervous system and the liver. Apart from an essential building block in proteins, tryptophan has other important effects that regulate vital biological mechanisms (Sidransky 1985). Although present in many proteins, tryptophan is the least abundant amino acid in the hepatic proteins, and usually degraded by two enzyme systems; indoleamine 2-3 dioxygenase (IDO) and tryptophan 2-3 dioxygenase (TDO). The latter enzyme is present only in the liver, therefore the kynurenine production which is in the downstream of the tryptophan metabolism pathway should only be due to increased TDO activity. The increased catalytic activity of TDO is determined by the substrate as a forward rate limiting step meanwhile other factors may also influence its activity. Amongst the actions on liver, tryptophan is known to cause induction hepatic alanine aminotransferase and aspartate aminotransferase by unknown mechanisms (Sidransky 1985). Tryptophan also has effect on the glucose metabolism in the liver and in isolated perfused liver in the experimental models, hepatic glucose synthesis is reduced by tryptophan, kynurenine and its metabolic products. Increased quinolinate and serotonin production has been implicated although the exact mechanisms of this action are unclear.

The above observations suggest that the increased hepatic transaminases seen following liver transplantation in the setting of severe graft dysfunction or primary non function may be related to increased activity of tryptophan-kynurenine pathway. Coupled with observations related to the glucose metabolism it opens up avenues for us to investigate this as a potential biomarker. The future work related to this aspect of research includes analysis of serum samples from organ recipients for tryptophan and kynurenine, and correlate these with the graft outcomes and conventionally measured alanine and aspartate aminotransferases. Through this pilot study we aim to

propose the significance of this novel biomarker in the prediction of liver allograft function in the post transplant period. Further option to study include monitoring of these biomarkers in the prospective liver graft recipients from pre-transplant time point to the post reperfusion period, which would eventually enable us decide on the reliability of this as a novel biomarker that could be used in the clinical transplantation setting.

7.3 Summary of future directions

To summarize the findings originating from our current studies, the DCD liver grafts which are considered “marginal” by nature showed significant differences in metabolic changes related to the primary energy metabolism, along with the grafts that failed following transplantation. It is likely that this is the end result of energy exhaustion, and further research on this aspect should be focused on replenishing intrahepatocytic energy stores during organ preservation, and that the mechanisms of study will involve insulin resistance and pathway analysis. Alongside, we propose to develop tryptophan and kynurenine as a novel biomarker to predict graft function, which may be directly or indirectly related to energy metabolism.

8.1 APPENDICES

Appendix 1: Hrydziuszko O, Silva MA, **Perera MTPR**, Richards DA, Murphy N, Mirza D, Viant MR. Application of metabolomics to investigate the process of human orthotopic liver transplantation: a proof-of-principle study. **OMICS**. 2010 Apr;14(2):143-50. doi: 10.1089/omi.2009.0139

Appendix 2: **Perera MTPR**, Richards DA, Silva MA, Ahmed N, Neil DA, Murphy N, Mirza DF. Comparison of energy metabolism in liver grafts from donors after circulatory death and donors after brain death during cold storage and reperfusion. **British Journal of Surgery**. 2014 Jun;101(7):775-83. doi: 10.1002/bjs.9478. Epub 2014 Apr 28

Appendix 3: Biomarker differences between cadaveric grafts used in human orthotopic liver transplantation as identified by Coulometric Electrochemical Array Detection (CEAD) metabolomics. **Perera MTPR**, Higdon R, Richards DA, Silva MA, Murphy N, Kolker E, Mirza DF. **OMICS**. 2014 Dec;18(12):767-77. doi: 10.1089/omi.2014.0094.

Appendix 4: Early occurrence of new-onset diabetes in liver transplant recipients is potentially related to the type of liver graft and warm ischaemic injury. Hartog H*, May C*, Corbett C, Murphy A, Peters L, Mirza DF, Tomlinson JW, **Perera MTPR**. **Liver Int**. 2014 Oct 27. doi: 10.1111/liv.12706. [Epub ahead of print]

8.1.1 Appendix 1

Application of Metabolomics to Investigate the Process of Human Orthotopic Liver Transplantation: A Proof-of-Principle Study

Olga Hrydziusko,^{1,*} Michael A. Silva,^{2,*} M. Thamara P. R. Perera,² Douglas A. Richards,³ Nick Murphy,² Darius Mirza,² and Mark R. Viant⁴

Abstract

To improve the outcome of orthotopic liver transplantation (OLT), knowledge of early molecular events occurring upon ischemia/reperfusion is essential. Powerful approaches for profiling metabolic changes in tissues and biofluids are now available. Our objective was to investigate the applicability of two technologies to a small but well-defined cohort of patients undergoing OLT: consecutive liver biopsies by Fourier transform ion cyclotron resonance mass spectrometry (FT-ICR MS) and microdialysates of extracellular fluid by coulometric electrochemical array detection (CEAD). FT-ICR MS detected reproducibly more than 4,000 peaks, revealing hundreds of significant metabolic differences between pre- and postreperfusion grafts. These included increased urea production, bile acid synthesis and clearance of preservation solution upon reperfusion, indicating a rapid resumption of biochemical function within the graft. FT-ICR MS also identified successfully the only graft obtained by donation-after-cardiac-death as a “metabolic outlier.” CEAD time-profile analysis showed that there was considerable change in redox-active metabolites (up to 18 h postreperfusion), followed by their stabilization. Collectively these results verify the applicability of FT-ICR MS and CEAD for characterizing multiple metabolic pathways during OLT. The success of this proof-of-principle application of these technologies to a clinical setting, considering the potential metabolic heterogeneity across only eight donor livers, is encouraging.

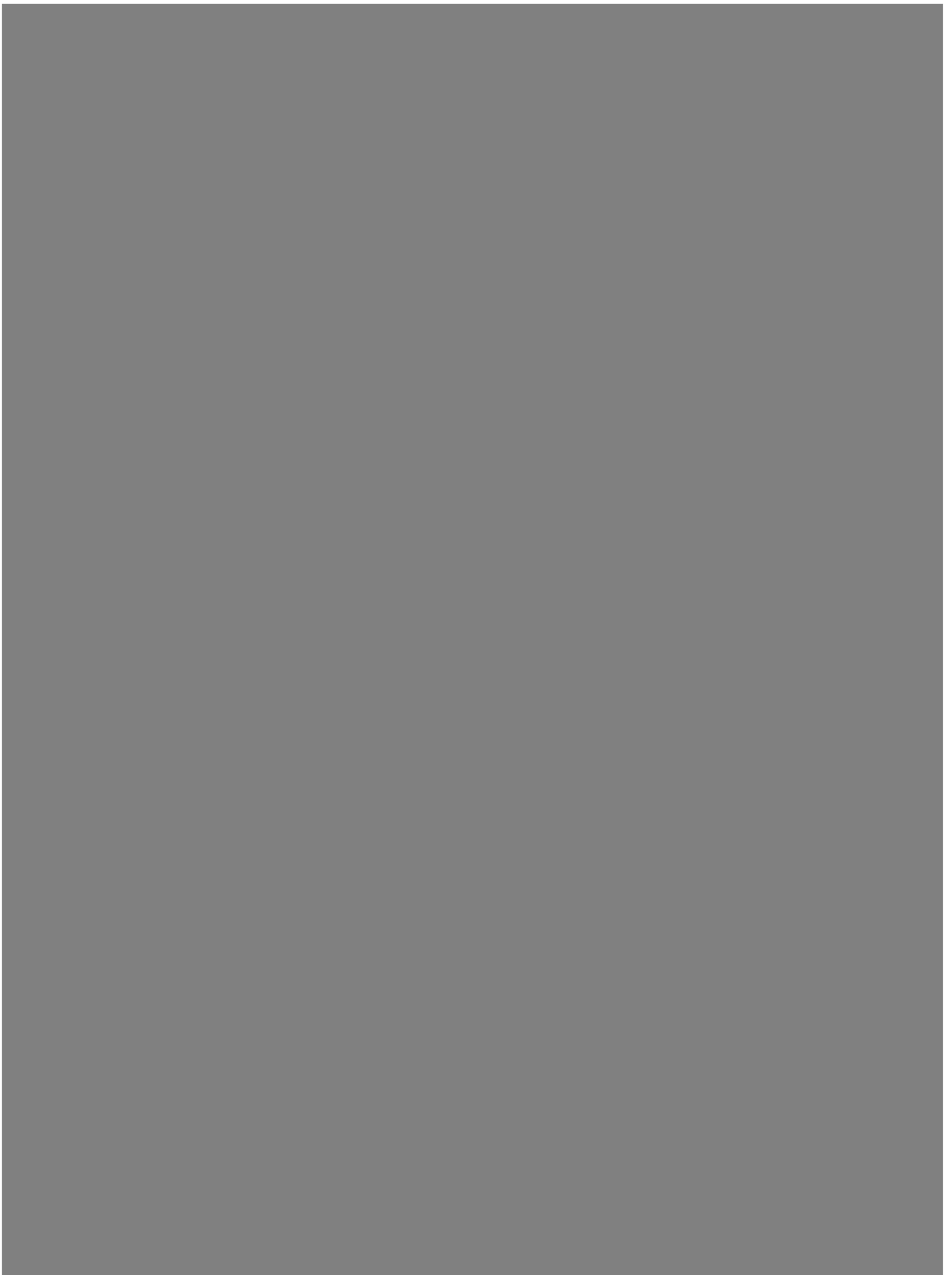

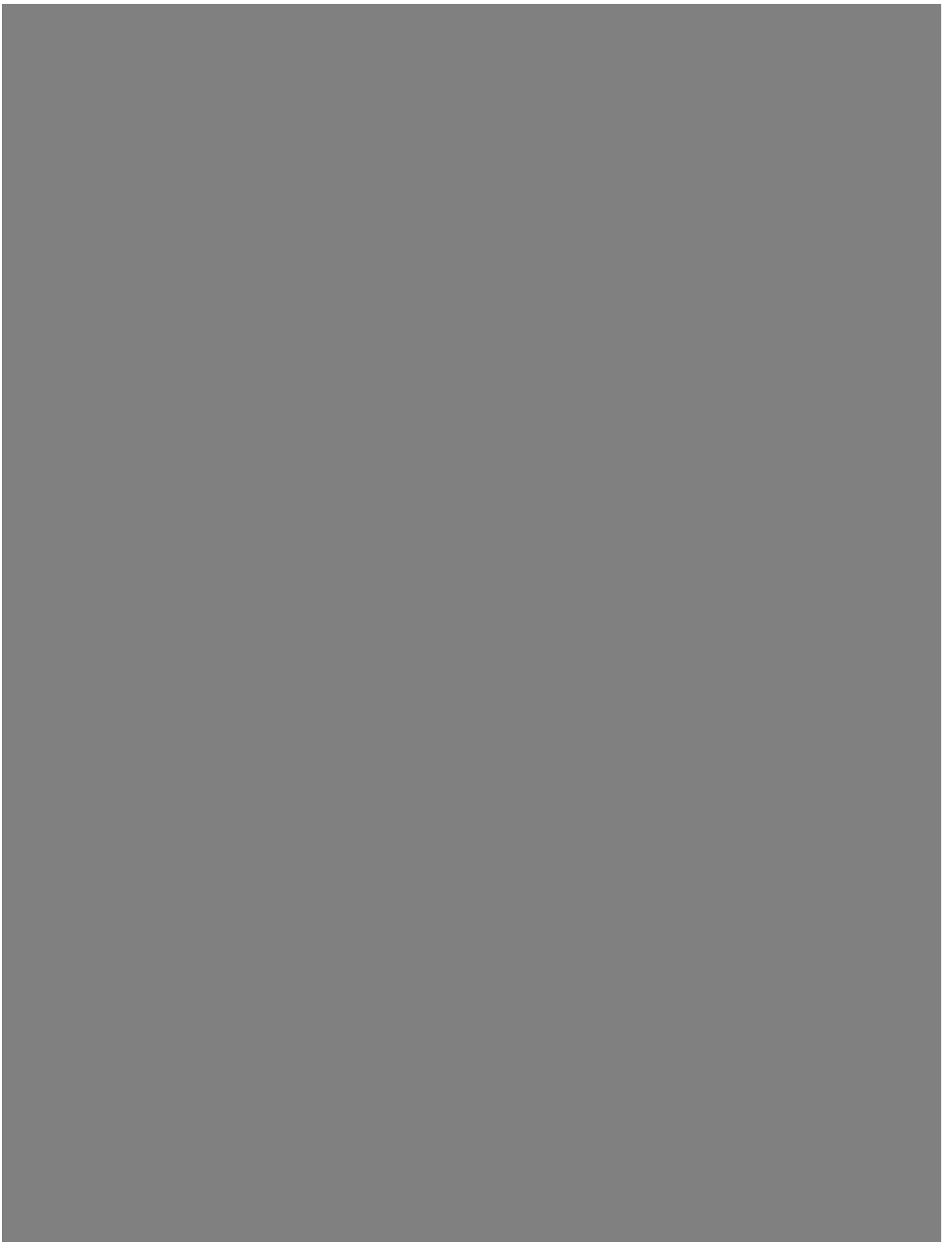

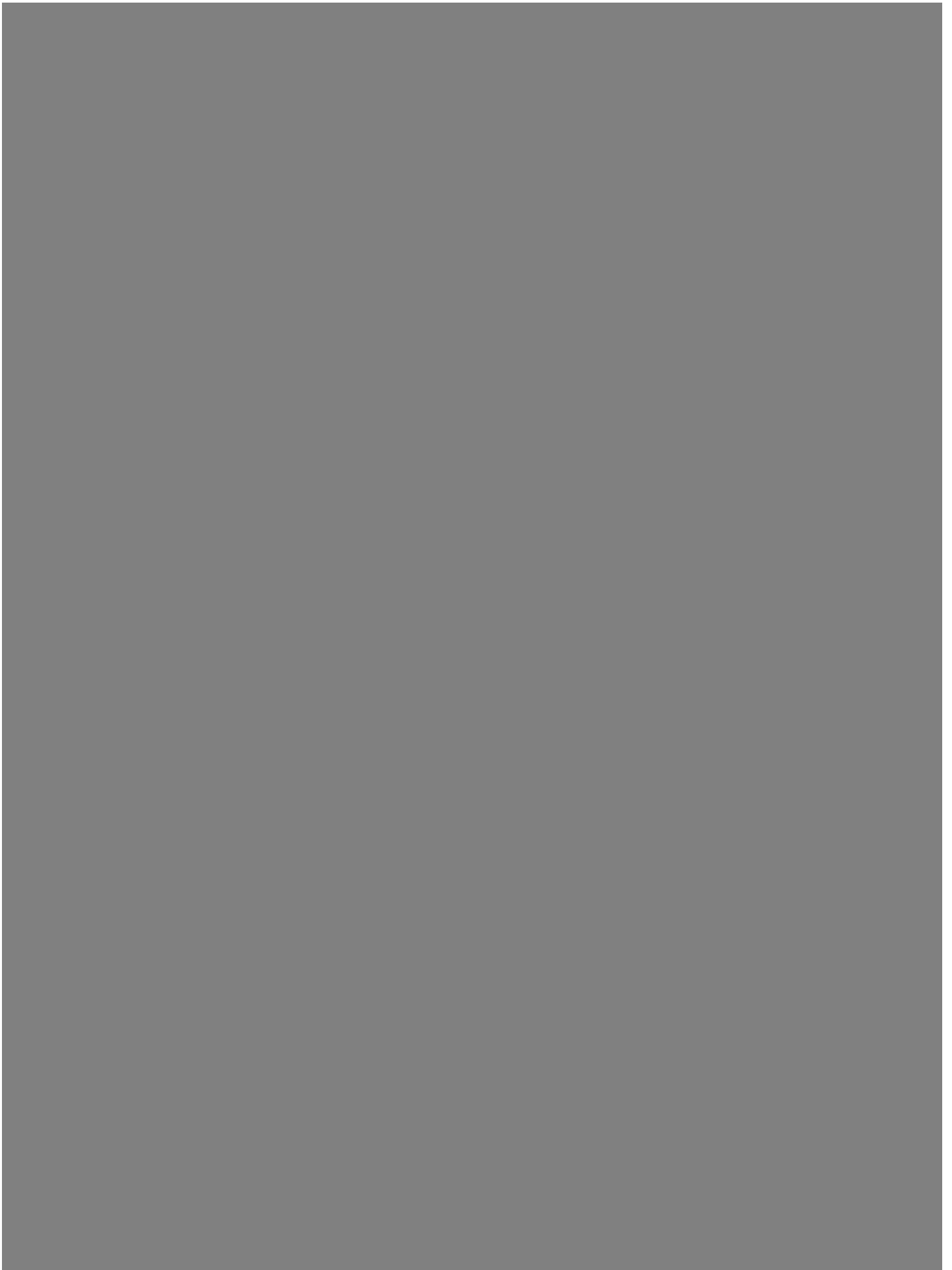

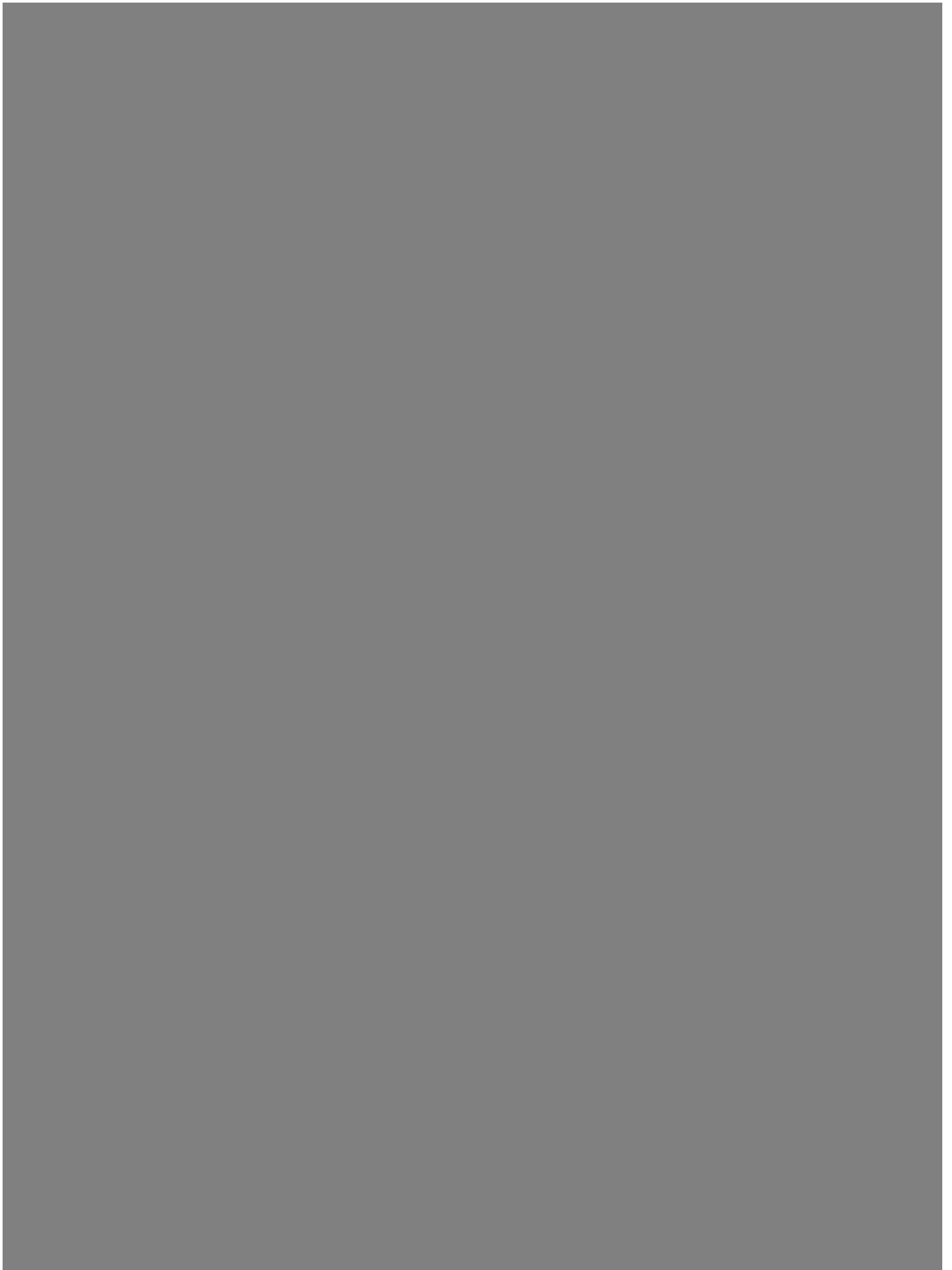

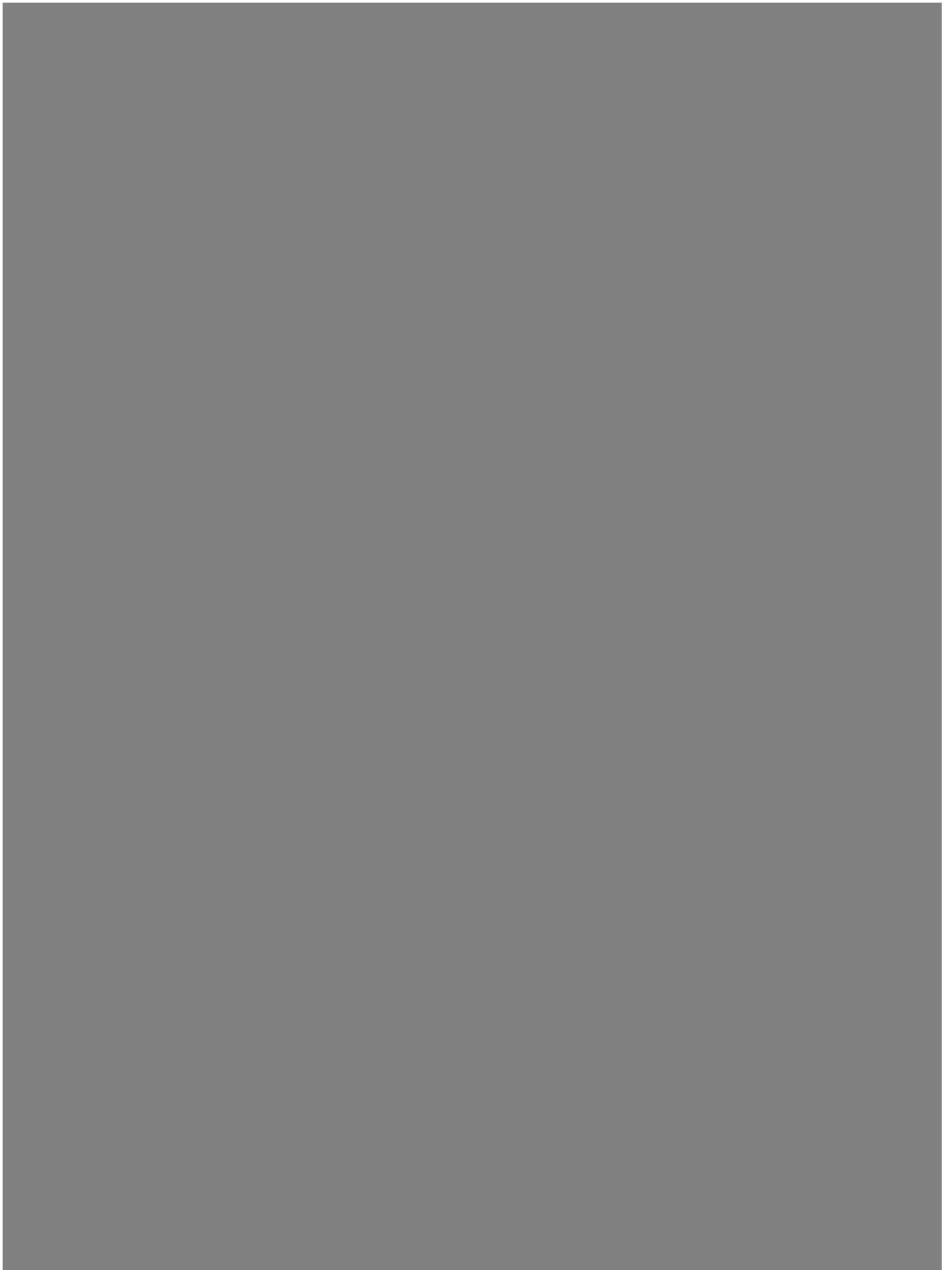





8.1.2 Appendix 2

Comparison of energy metabolism in liver grafts from donors after circulatory death and donors after brain death during cold storage and reperfusion

M. T. P. R. Perera¹, D. A. Richards⁴, M. A. Silva¹, N. Ahmed¹, D. A. Neil², N. Murphy³ and D. F. Mirza¹

¹Liver Unit, and Departments of ²Pathology and ³Critical Care, Queen Elizabeth Hospital Birmingham, ⁴Pharmacy, Pharmacology and Therapeutics, School of Clinical and Experimental Medicine, Medical School, University of Birmingham, Edgbaston, Birmingham, UK

Correspondence to: Mr M. T. P. R. Perera, Liver Unit, Queen Elizabeth Hospital Birmingham, Edgbaston, Birmingham B15 2TH, UK (e-mail: thamara.perera@uhb.nhs.uk)

Background: Donation after circulatory death (DCD) liver grafts have supplemented the donor organ pool, but certain adverse outcomes have prevented exploration of the full potential of such organs. The aim of this study was to determine key differences in basic energy metabolism between DCD and donation after brainstem death (DBD) grafts.

Methods: Microdialysis samples from DCD and DBD allograft parenchyma from cold storage to 48 h after reperfusion were analysed by colorimetric methods. Interstitial lactate, pyruvate and glycerol levels were measured and the lactate/pyruvate ratio was calculated to estimate energy depletion of the grafts. Histological features of ischaemia and reperfusion injury were assessed.

Results: Donor age, extent of steatosis and cold ischaemia time were comparable between ten DCD and 20 DBD organs. DCD grafts had higher levels of interstitial lactate (median 11.6 *versus* 1.2 mmol/l; $P = 0.015$) and increased lactate/pyruvate ratio (792 *versus* 38; $P = 0.001$) during cold storage. There was no significant difference in glycerol levels between DCD and DBD grafts (225.1 *versus* 127.5 $\mu\text{mol/l}$ respectively; $P = 0.700$). Rapid restoration of energy levels with lactate clearance, increased pyruvate levels and reduced lactate/pyruvate ratio was seen following reperfusion of functioning DCD grafts, parallel with levels in DBD grafts. Histology revealed more pronounced glycogen depletion in DCD grafts. Three allografts that failed owing to primary non-function showed energy exhaustion with severe glycogen depletion.

Conclusion: Liver grafts from DCD donors exhibited depletion of intracellular energy reserves during cold storage. Failed allografts showed severe energy depletion. Modified organ preservation techniques to minimize organ injury related to altered energy metabolism may enable better utilization of donor organs after circulatory death.

Paper accepted 28 January 2014

Published online in Wiley Online Library (www.bjs.co.uk). DOI: 10.1002/bjs.9478

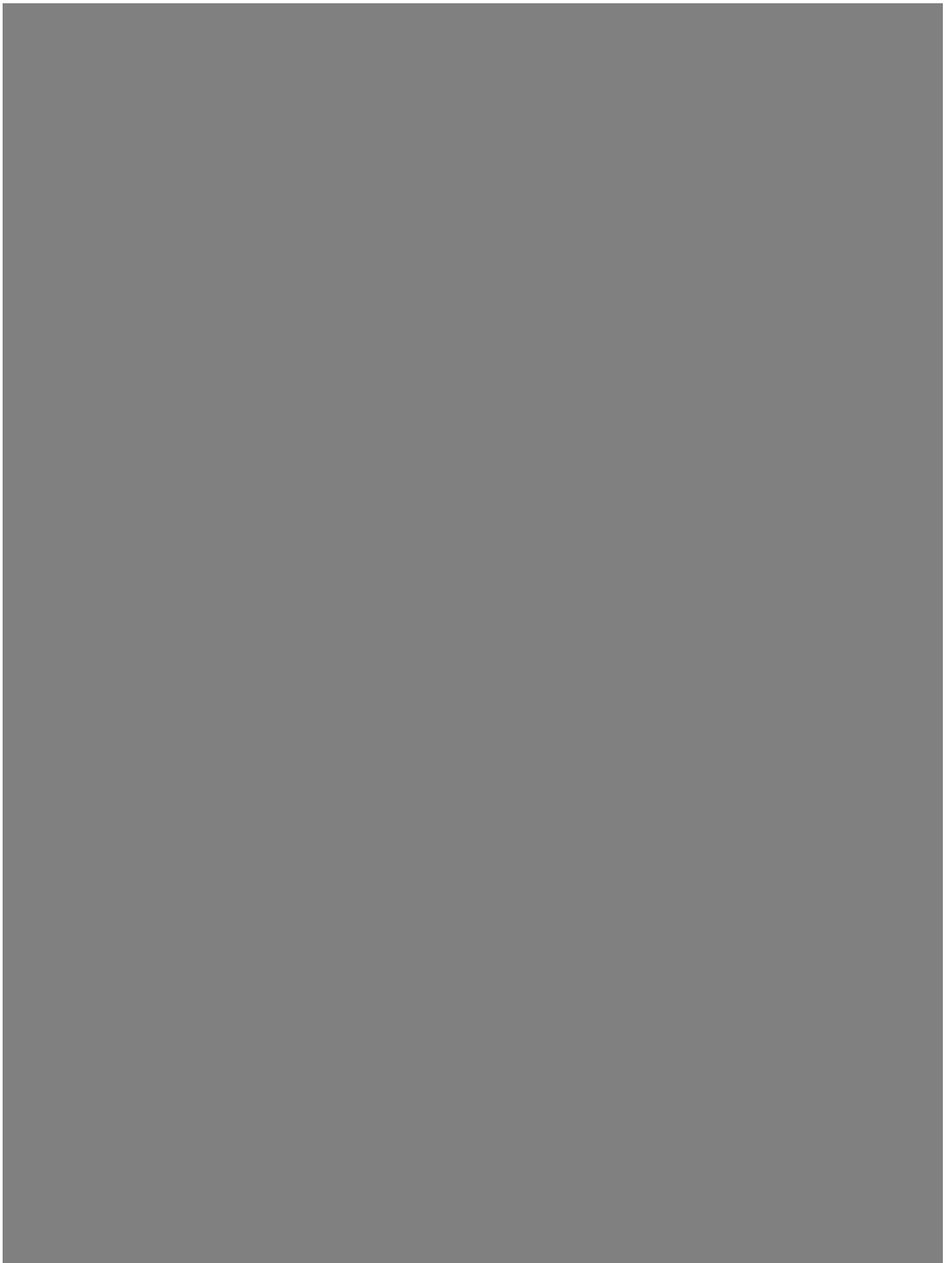

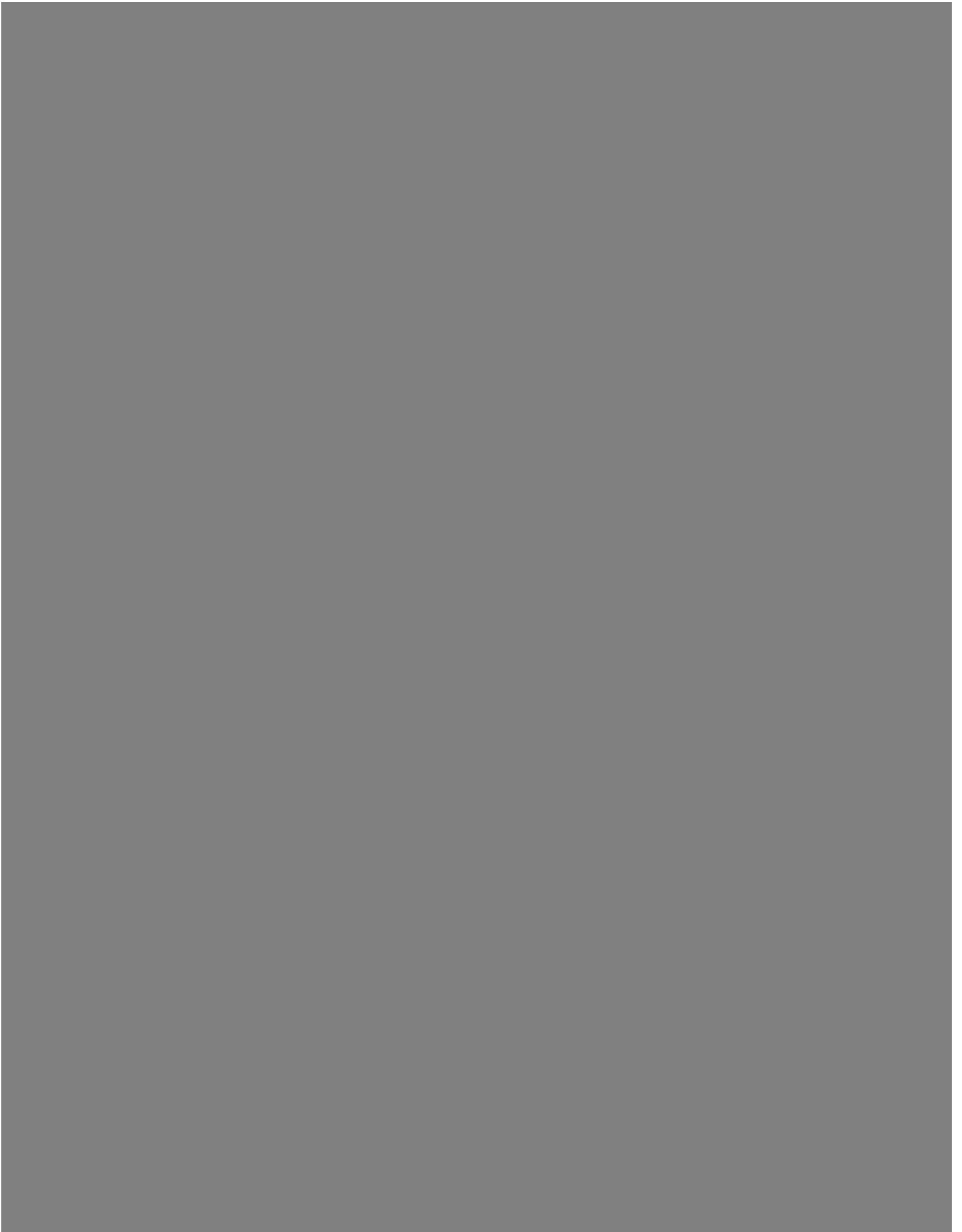

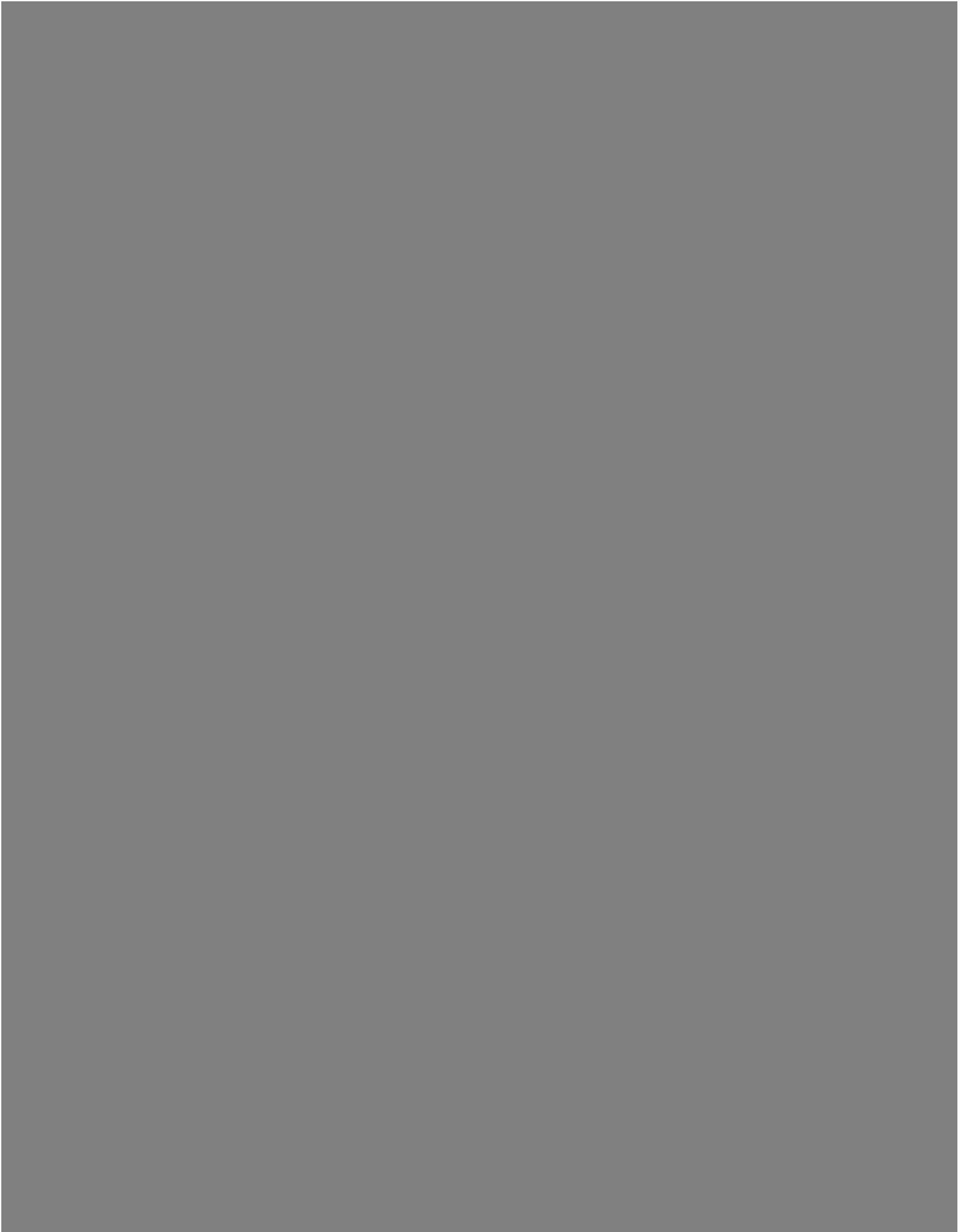

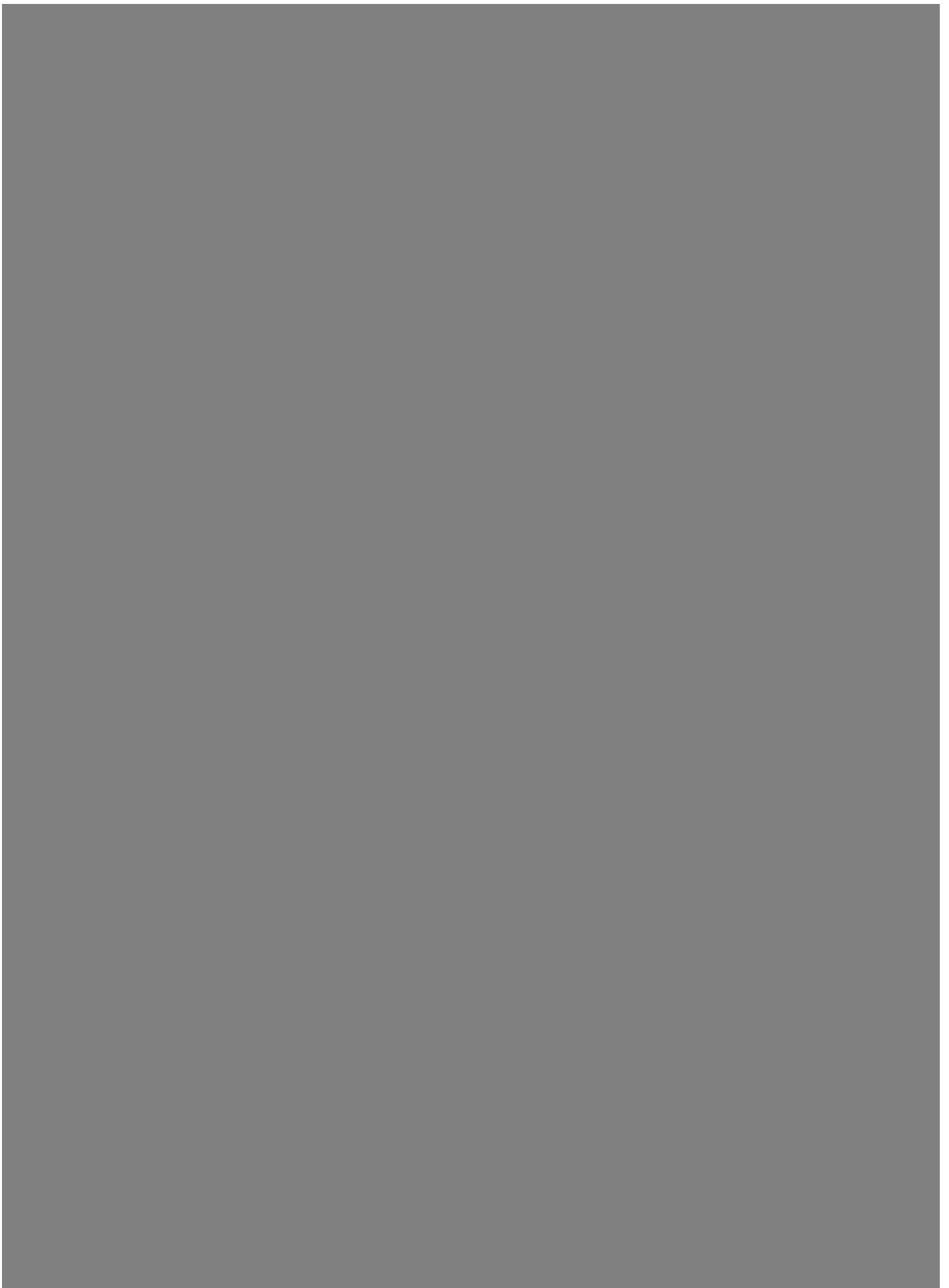

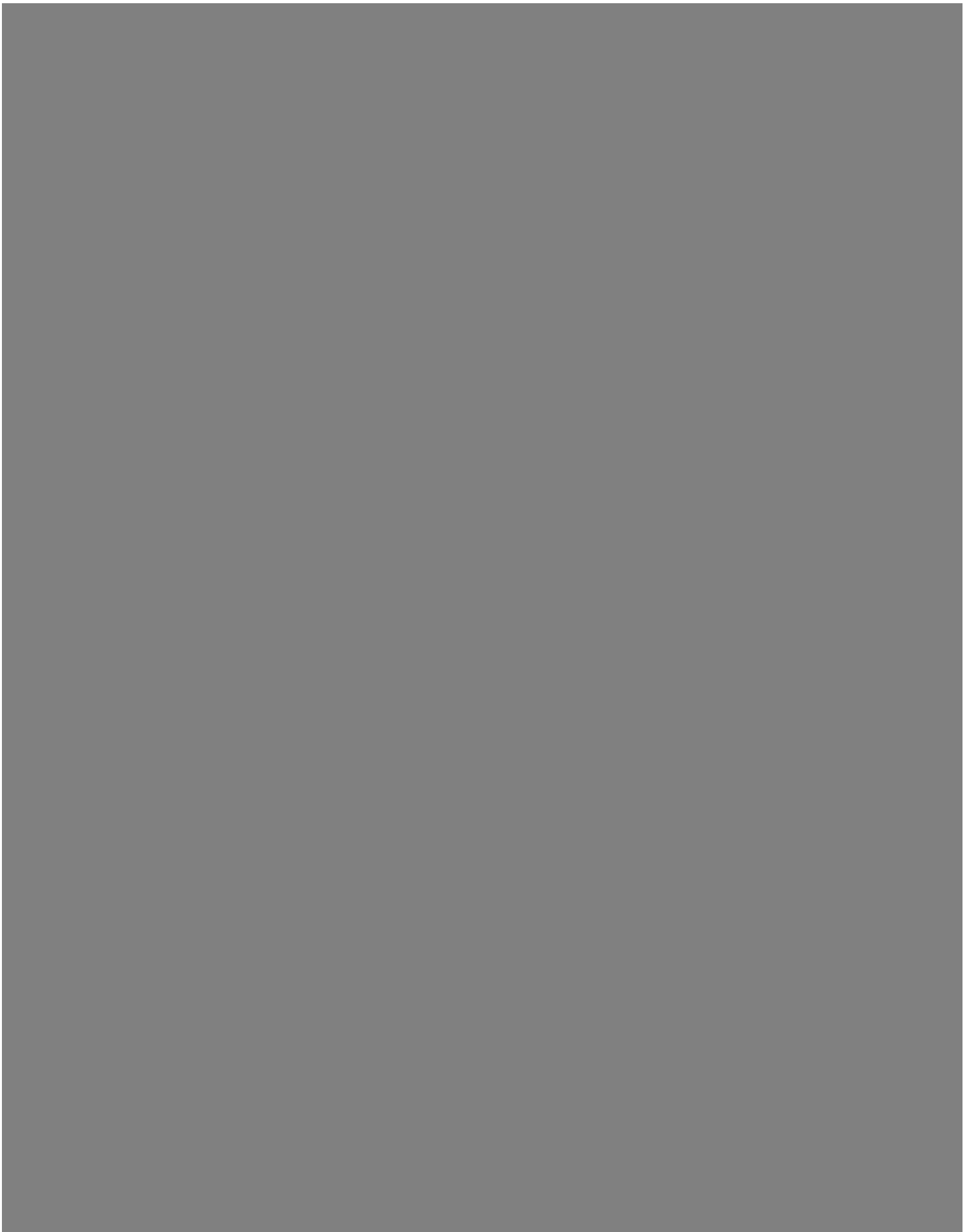

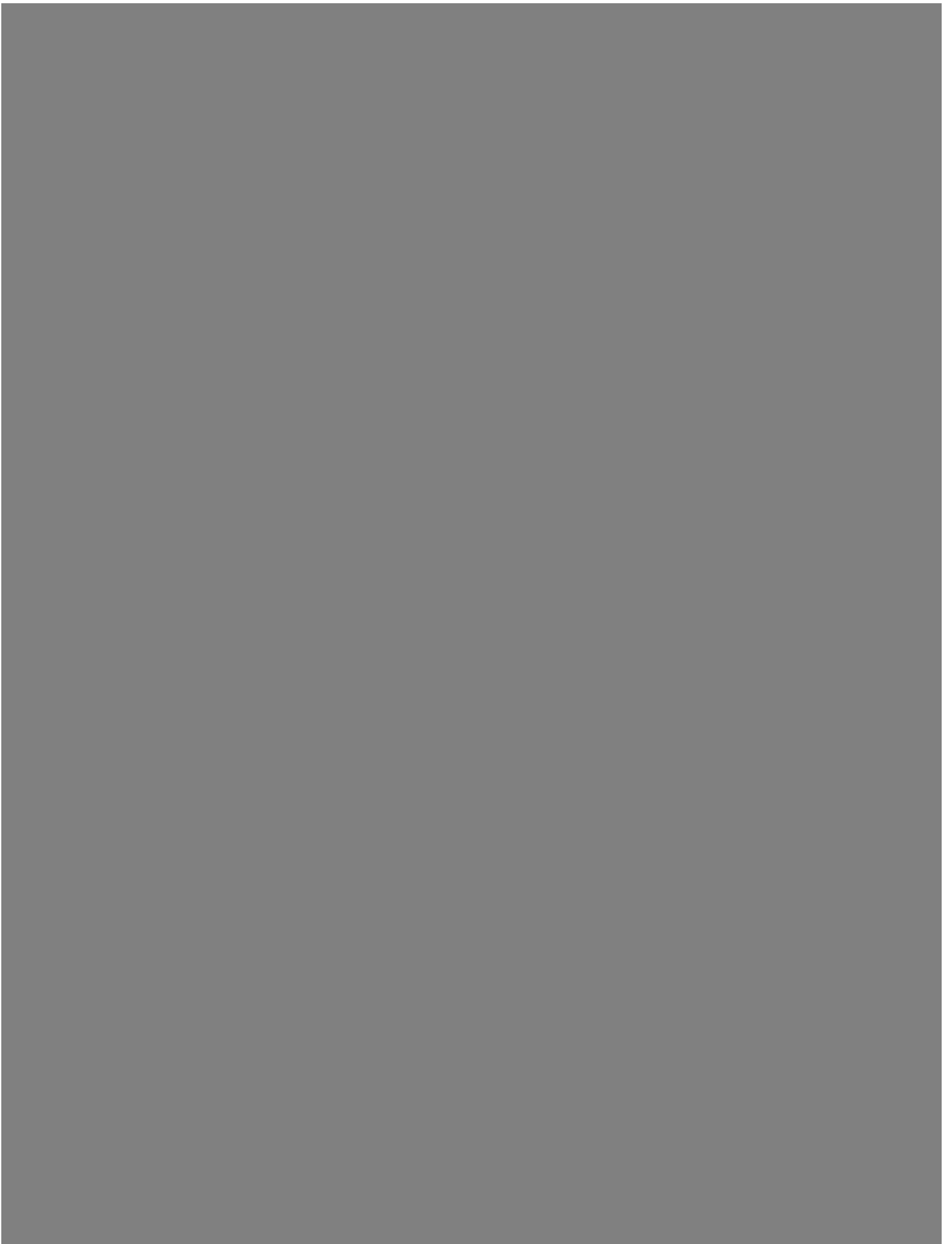

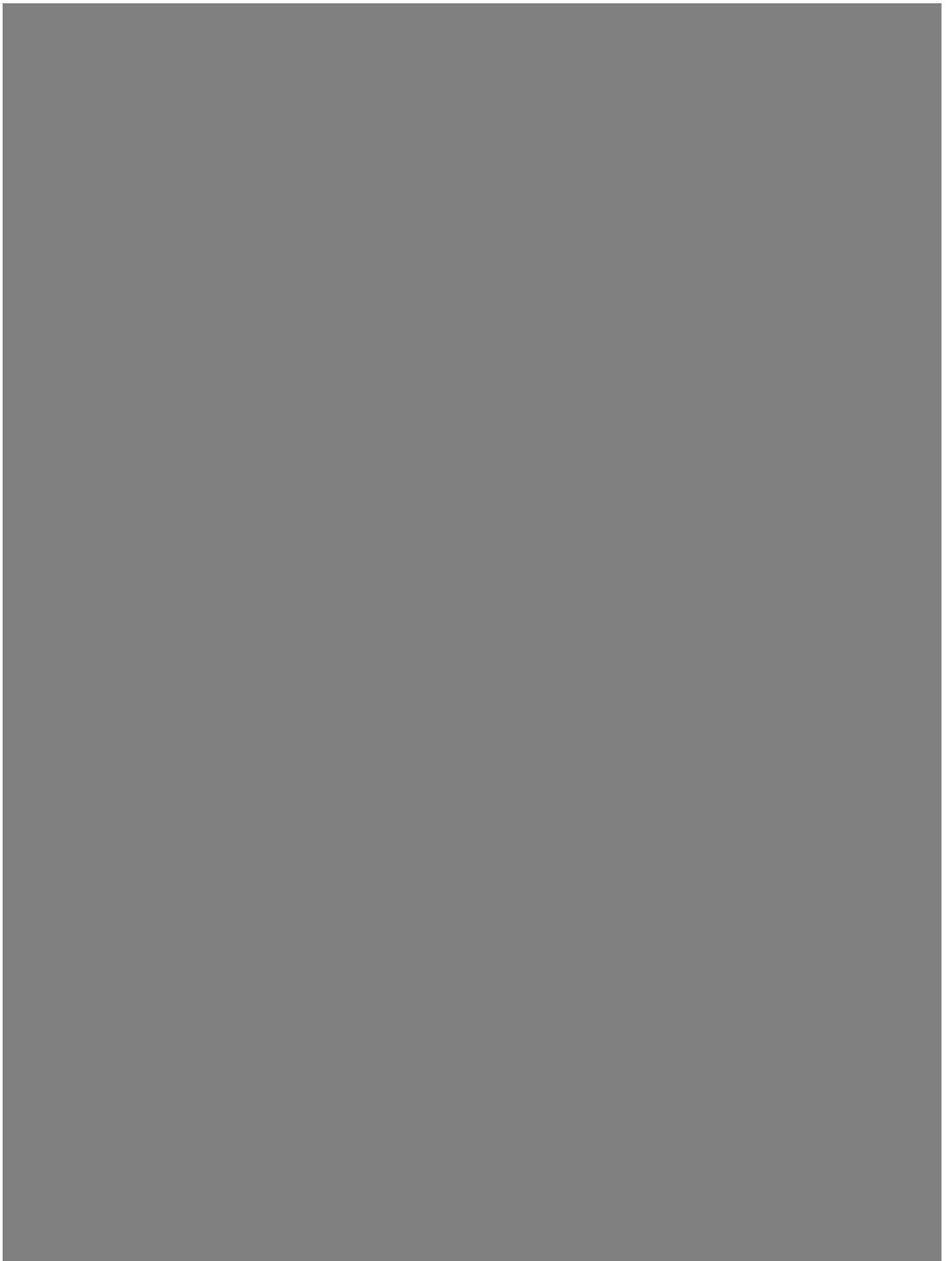



8.1.3 Appendix 3

Biomarker Differences between Cadaveric Grafts Used in Human Orthotopic Liver Transplantation as Identified by Coulometric Electrochemical Array Detection (CEAD) Metabolomics

M. Thamara P.R. Perera,^{1*} Roger Higdon,^{2,3*} Douglas A. Richards,⁴ Michael A. Silva,¹ Nick Murphy,⁵ Eugene Kolker,^{2,3,6,7} and Darius F. Mirza¹

Abstract

Metabolomics in systems biology research unravels intracellular metabolic changes by high throughput methods, but such studies focusing on liver transplantation (LT) are limited. Microdialysate samples of liver grafts from donors after circulatory death (DCD; $n=13$) and brain death (DBD; $n=27$) during cold storage and post-reperfusion phase were analyzed through coulometric electrochemical array detection (CEAD) for identification of key metabolomics changes. Metabolite peak differences between the graft types at cold phase, post-reperfusion trends, and in failed allografts, were identified against reference chromatograms. In the cold phase, xanthine, uric acid, and kynurenine were overexpressed in DCD by 3-fold, and 3-nitrotyrosine (3-NT) and 4-hydroxy-3-methoxymandelic acid (HMMA) in DBD by 2-fold ($p < 0.05$). In both grafts, homovanillic acid and methionine increased by 20%–30% with each 100 min increase in cold ischemia time ($p < 0.05$). Uric acid expression was significantly different in DCD post-reperfusion. Failed allografts had overexpression of reduced glutathione and kynurenine (cold phase) and xanthine (post-reperfusion) ($p < 0.05$). This differential expression of metabolites between graft types is a novel finding, meanwhile identification of overexpression of kynurenine in DCD grafts and in failed allografts is unique. Further studies should examine kynurenine as a potential biomarker predicting graft function, its causation, and actions on subsequent clinical outcomes.

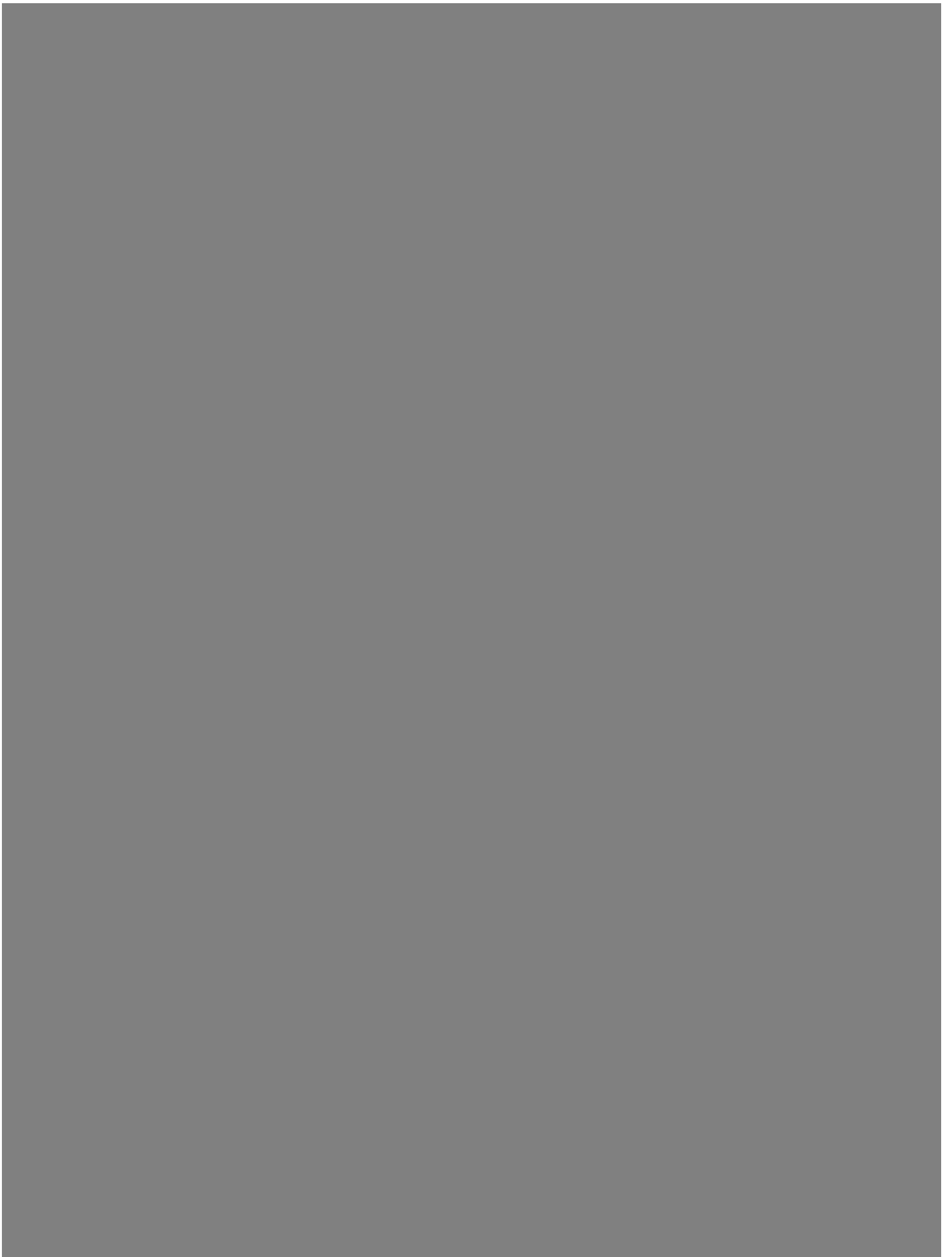

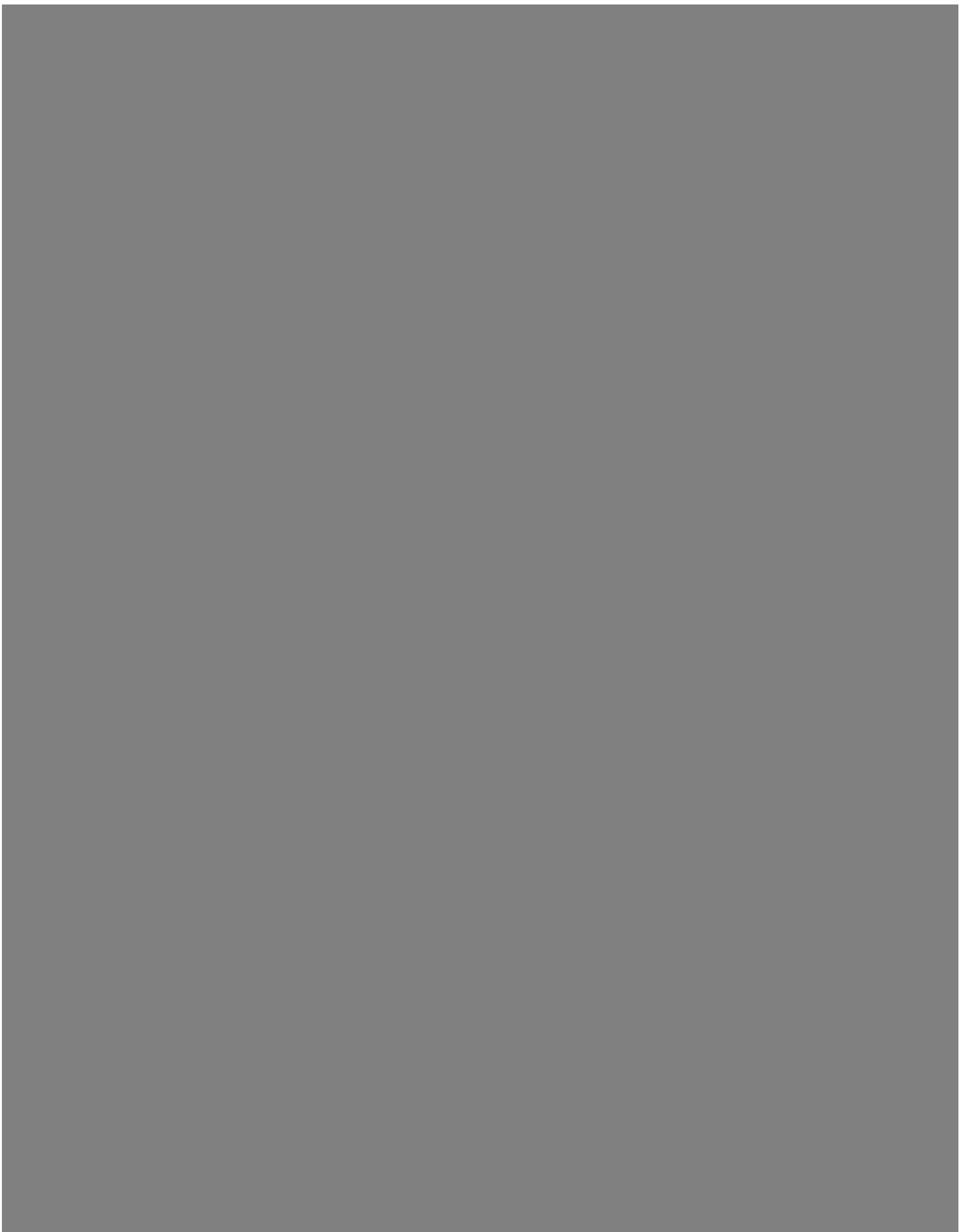

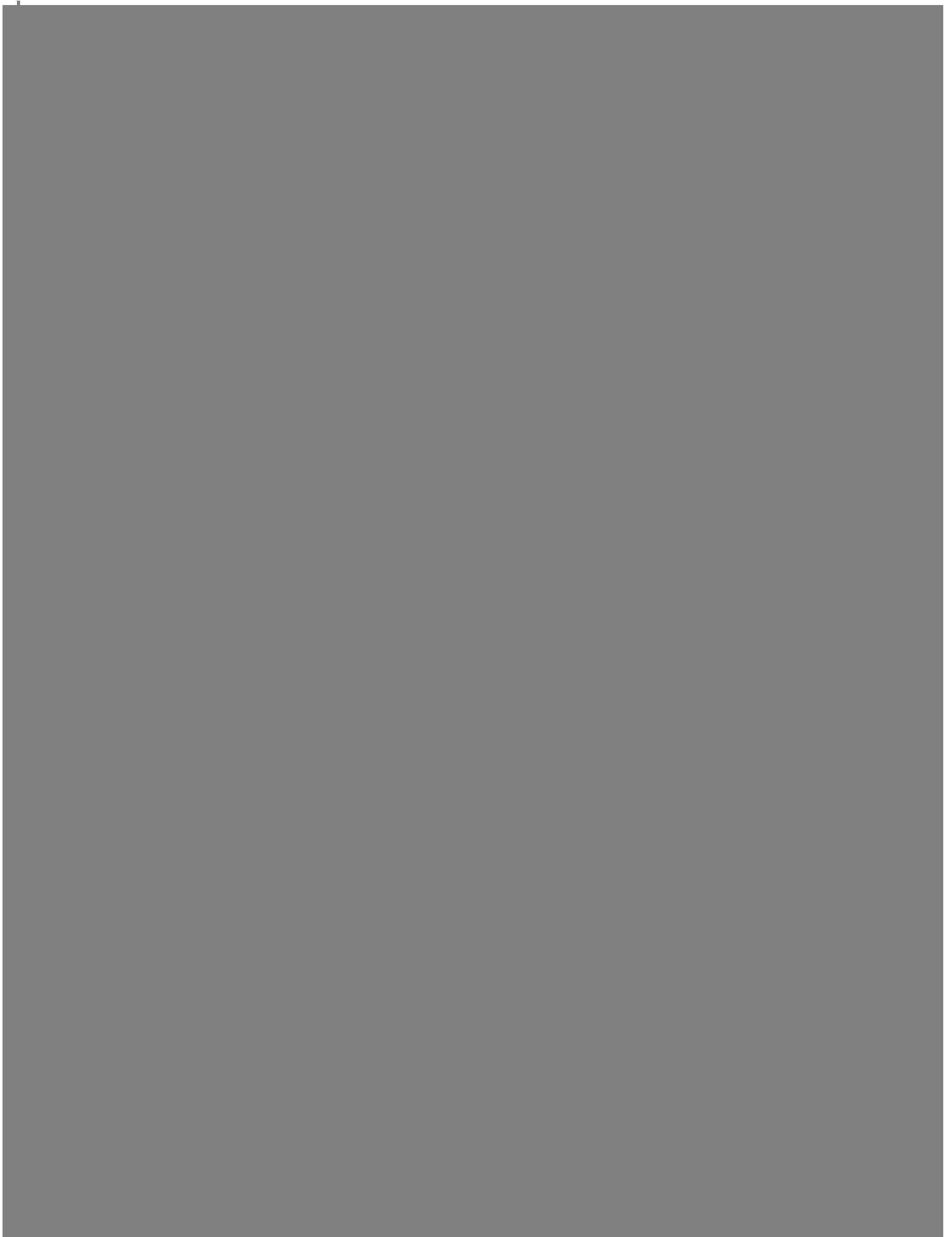

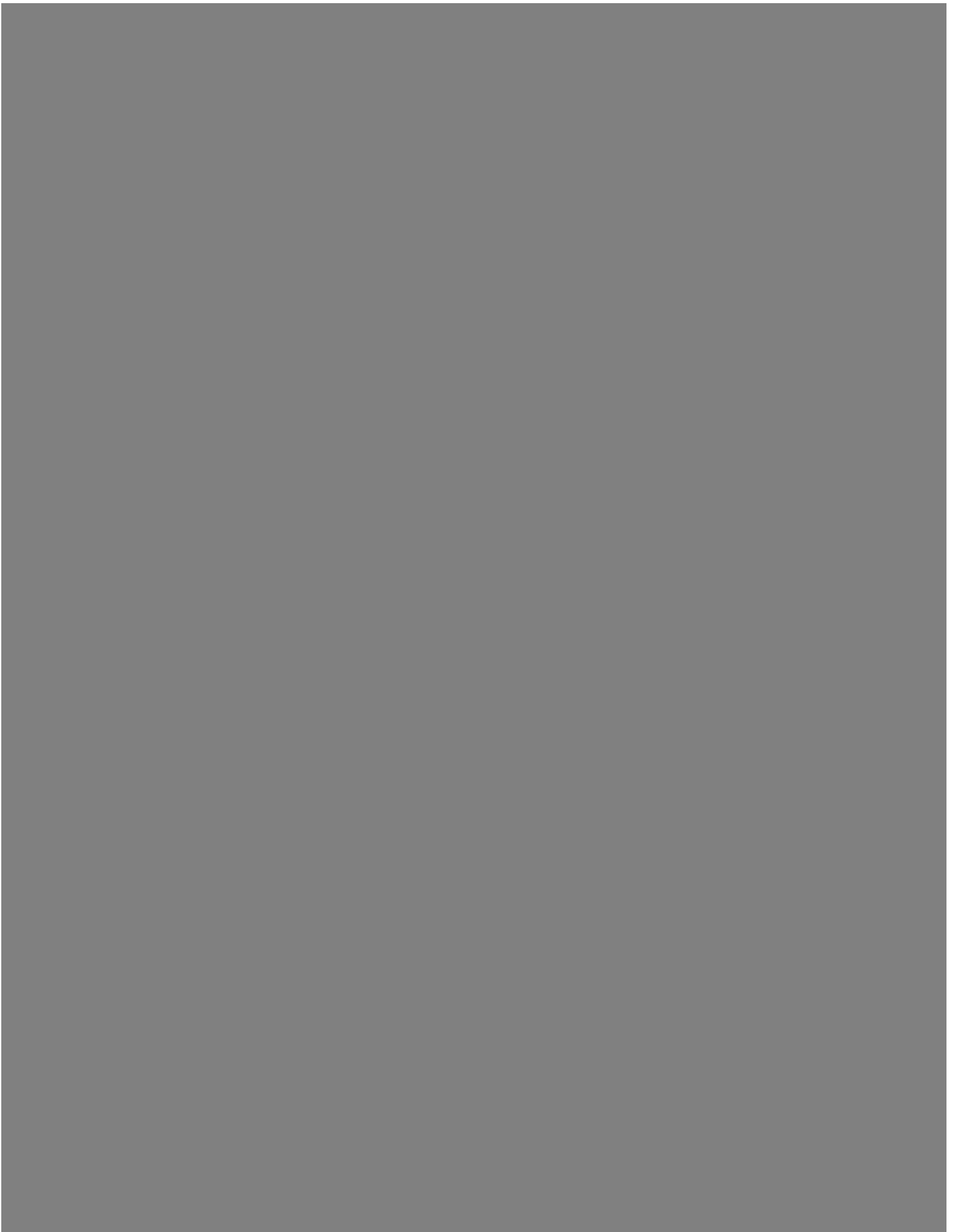

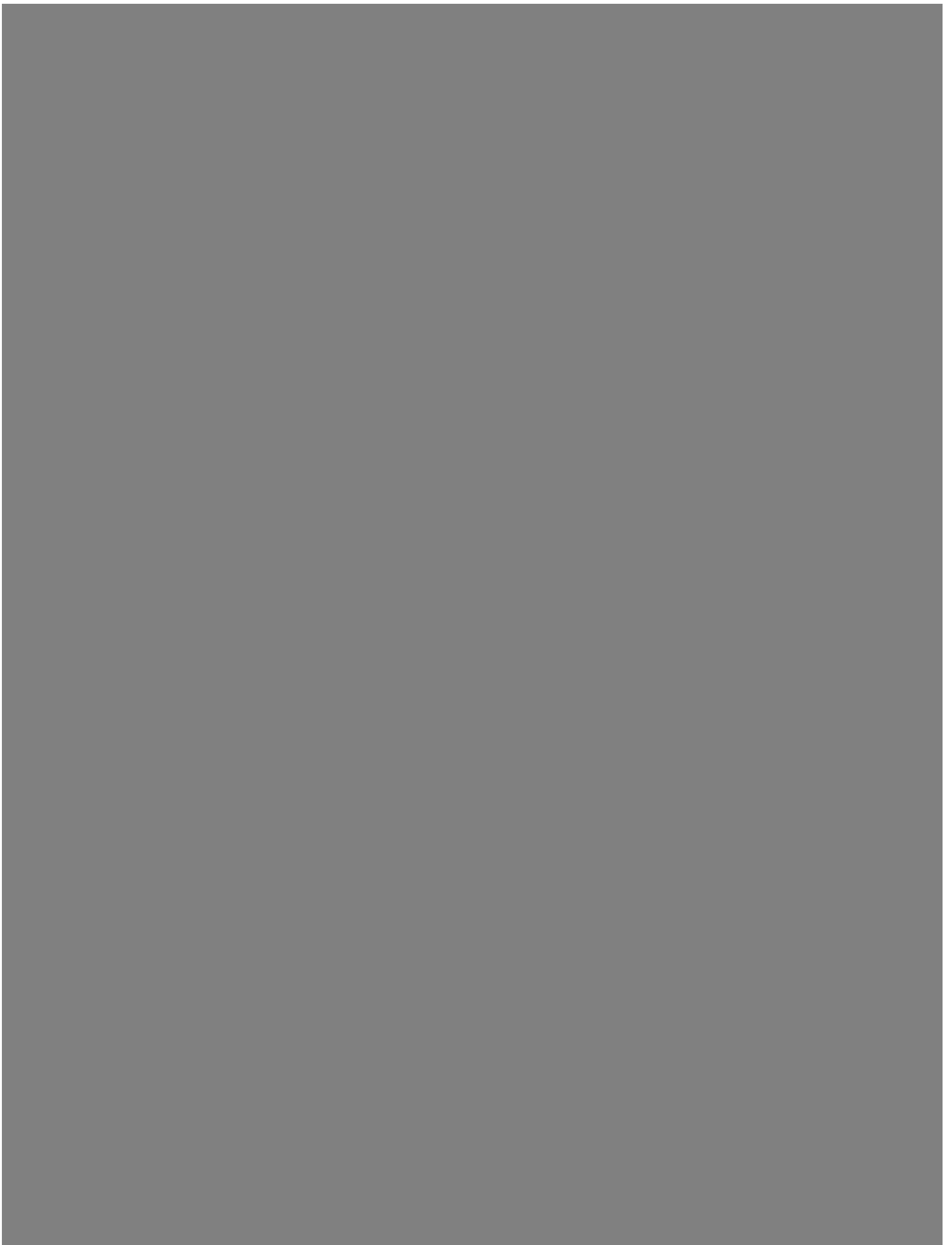

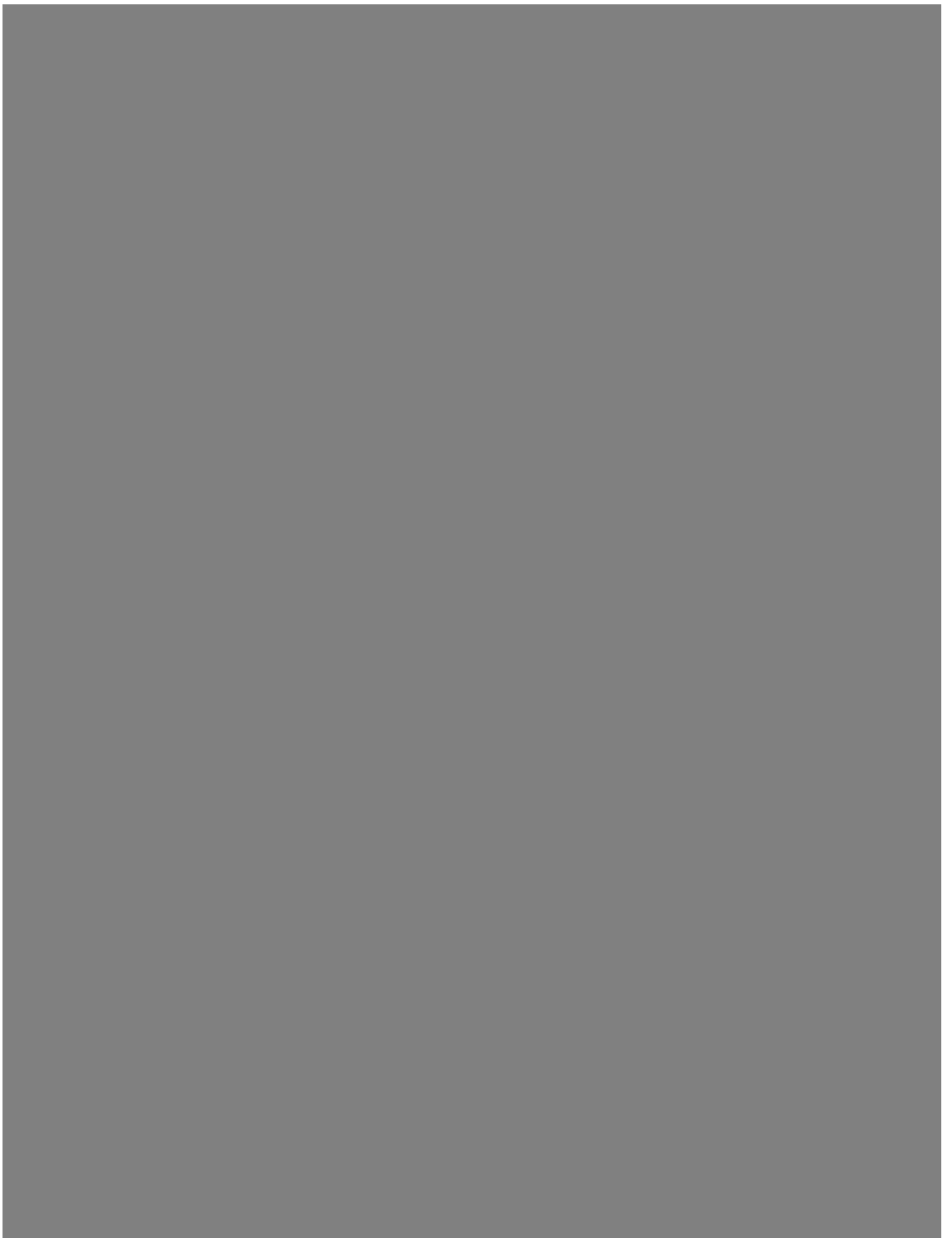

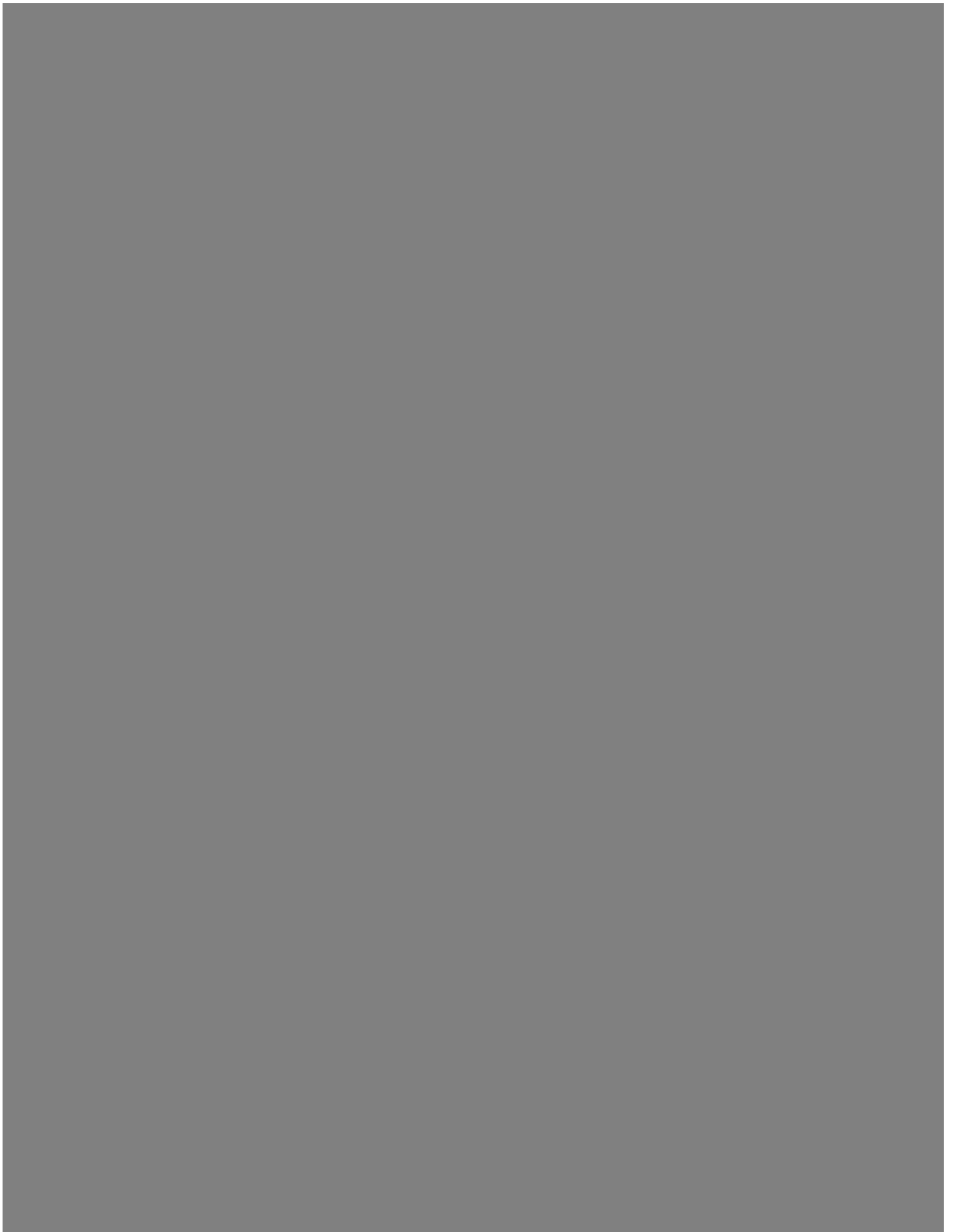



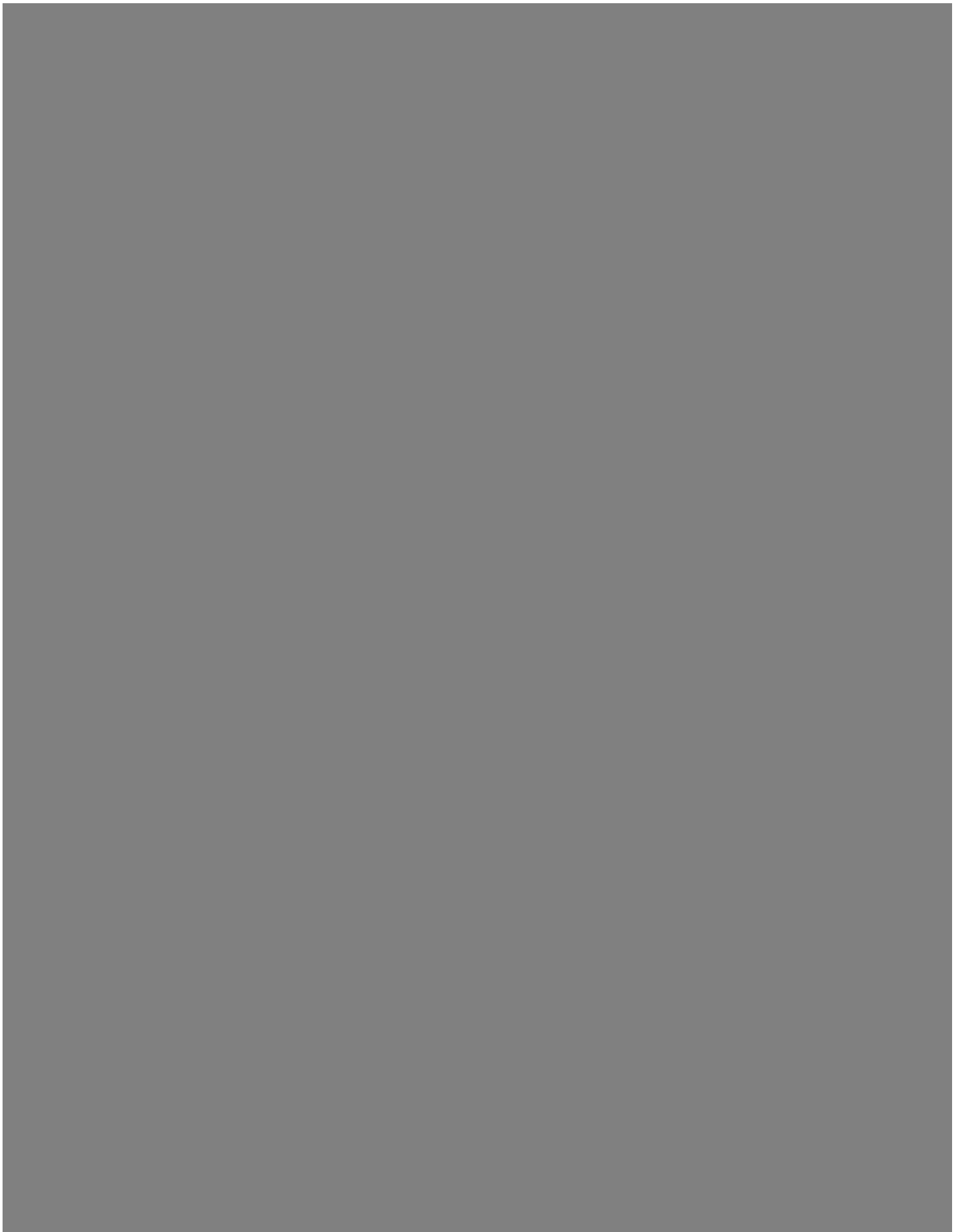



8.1.4 Appendix 4

ORIGINAL ARTICLE

Early occurrence of new-onset diabetes after transplantation is related to type of liver graft and warm ischaemic injury

Hermien Hartog^{1*}, Christine J.H. May^{2*}, Chris Corbett¹, Angela Phillips², Jeremy W. Tomlinson³, Hynek Mergental¹, John Isaac¹, Simon Bramhall¹, Darius F. Mirza¹, Paolo Muiesan¹ and M. Thamara P.R. Perera¹

1 Liver Unit, Queen Elizabeth Hospital Birmingham, Edgbaston, Birmingham, UK

2 Diabetes Center, Queen Elizabeth Hospital Birmingham, Edgbaston, Birmingham, UK

3 Institute of Biomedical research, University of Birmingham, Birmingham, UK

Keywords

diabetes mellitus – donation after circulatory death – hyperglycaemia – liver transplantation – NODAT

Abbreviations

BMI, body-mass index; DBD, donation after brain death; DCD, donation after circulatory death; DDLT, deceased donor liver transplantation; HbA1c, glycated haemoglobin; HCV, hepatitis C virus; IR, insulin receptor; IRS, insulin receptor substrate; LRLT, living-related liver transplantation; LT, liver transplantation; NODAT, new-onset diabetes after transplantation; OPTN/UNOS, the organ procurement and transplant network/united network for organ sharing; PI3K, phosphoinositide-3 kinase.

Correspondence

Thamara P.R. Perera, FRCS
Consultant Transplant Surgeon
Queen Elizabeth Hospital Birmingham
B15 2TH, Birmingham, UK
Tel: +44121 371 4637
Fax: +44 121 414 1833
e-mail: thamara.perera@uhb.nhs.uk

Received 14 August 2014

Accepted 20 October 2014

DOI:10.1111/liv.12706

Abstract

Background & Aims: We studied new-onset diabetes after transplantation (NODAT) in liver transplantation with grafts donated after brain death (DBD) or circulatory death (DCD), focusing on the early post-transplant period. **Methods:** A total of 430 non-diabetic primary liver transplant recipients [DCD, $n = 90$ (21%)] were followed up for 30 months (range 5–69). NODAT was defined as the composite endpoint of one of following: (i) Two non-fasting plasma glucose levels > 11.1 mmol/L ≥ 30 days apart, (ii) oral hypoglycaemic drugs ≥ 30 days consecutively (iii) insulin therapy ≥ 30 days and (iv) HbA1c ≥ 48 mmol/L. Resolution of NODAT was defined as cessation of treatment or hyperglycaemia. **Results:** Total of 81/430 (19%) patients developed NODAT. Incidence and resolution of NODAT over time showed significantly different patterns between DCD and DBD liver graft recipients; early occurrence, high peak incidence and early resolution were seen in DCD. In multivariate logistic regression including age, ethnicity, HCV, tacrolimus level and pulsed steroids, only DCD was independently associated with NODAT at day 15 post-transplant (OR 6.5, 95% CI 2.3–18.4, $P < 0.001$), whereas age and pulsed steroids were significant factors between 30–90 days. Combined in multivariate Cox regression model for NODAT-free survival, graft type, age and pulsed steroids were each independent predictor for decreased NODAT-free survival in the first 90-postoperative days. **Conclusion:** Early peak of NODAT in DCD graft recipients is a novel finding, occurring independently from known risk factors. Donor warm ischaemia and impact on insulin sensitivity should be further studied and could perhaps be associated with graft function.

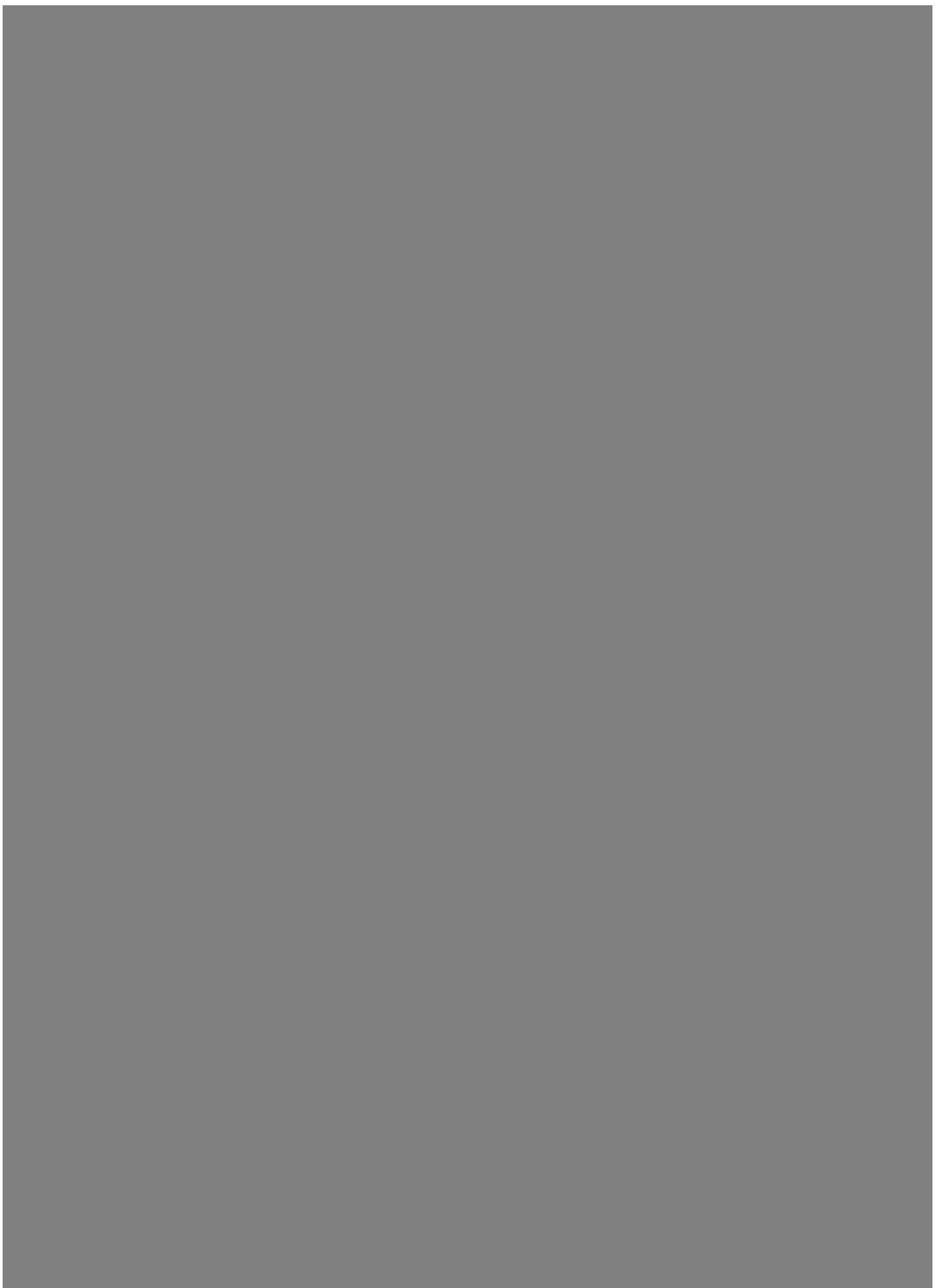

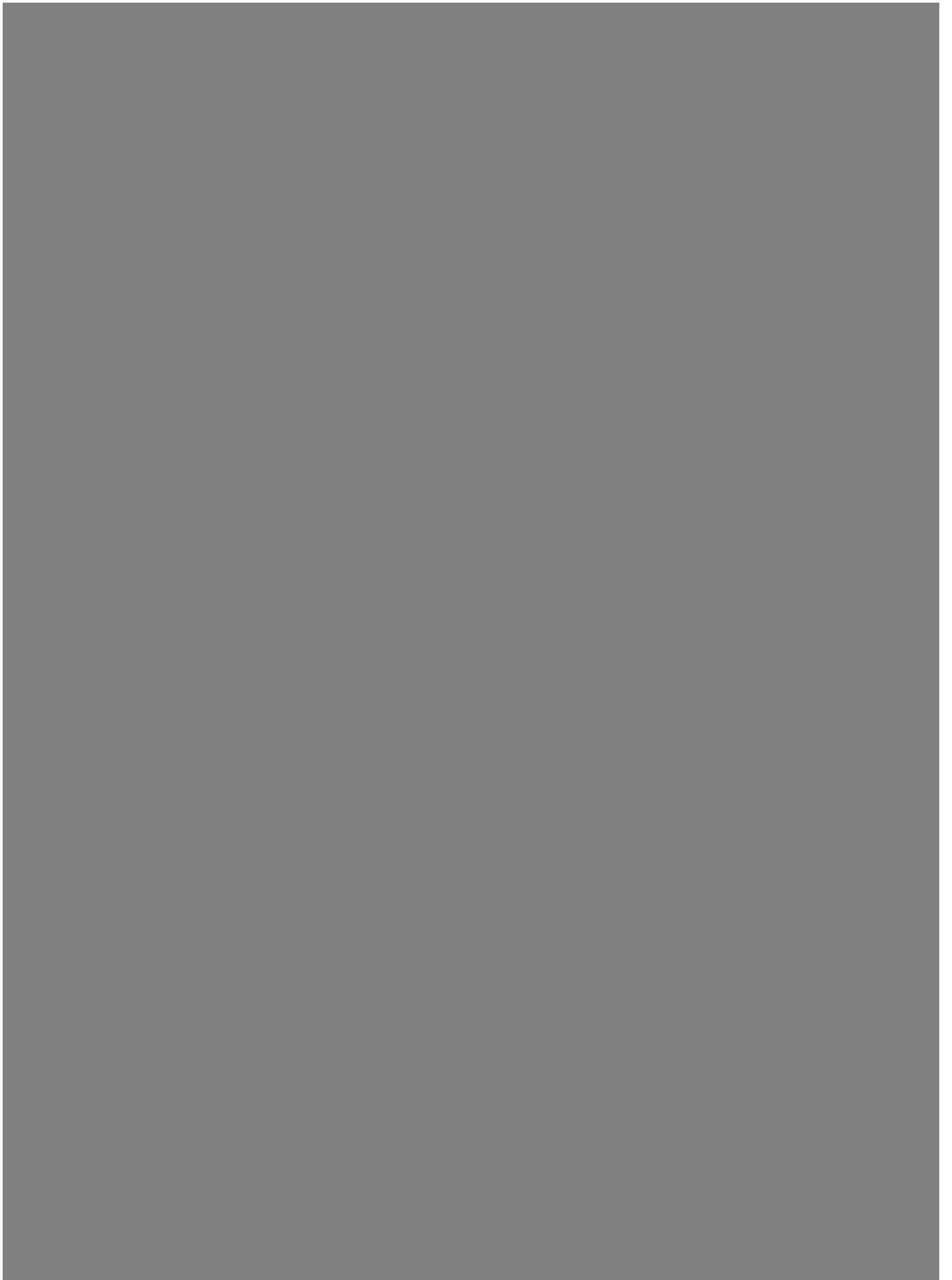

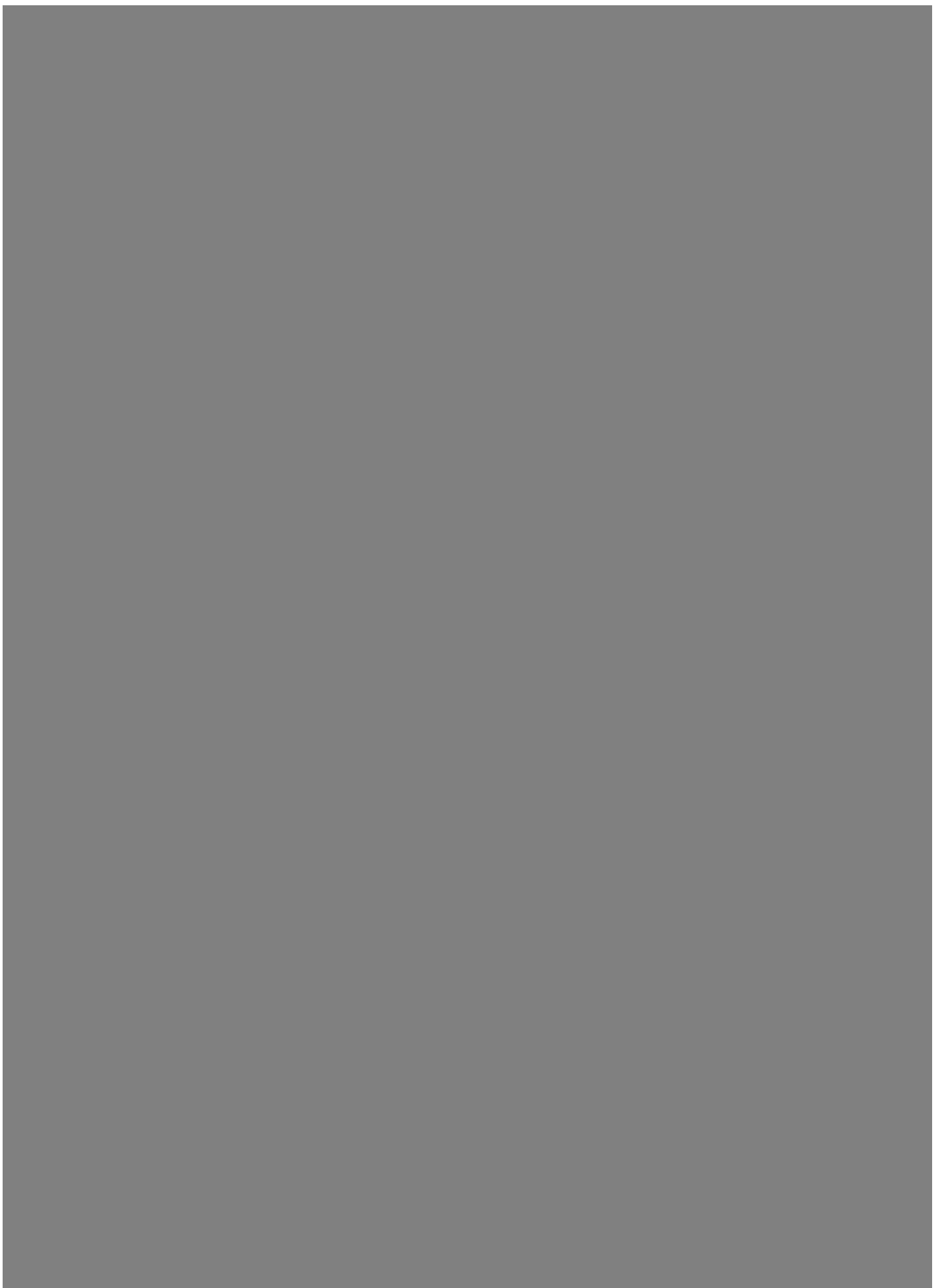

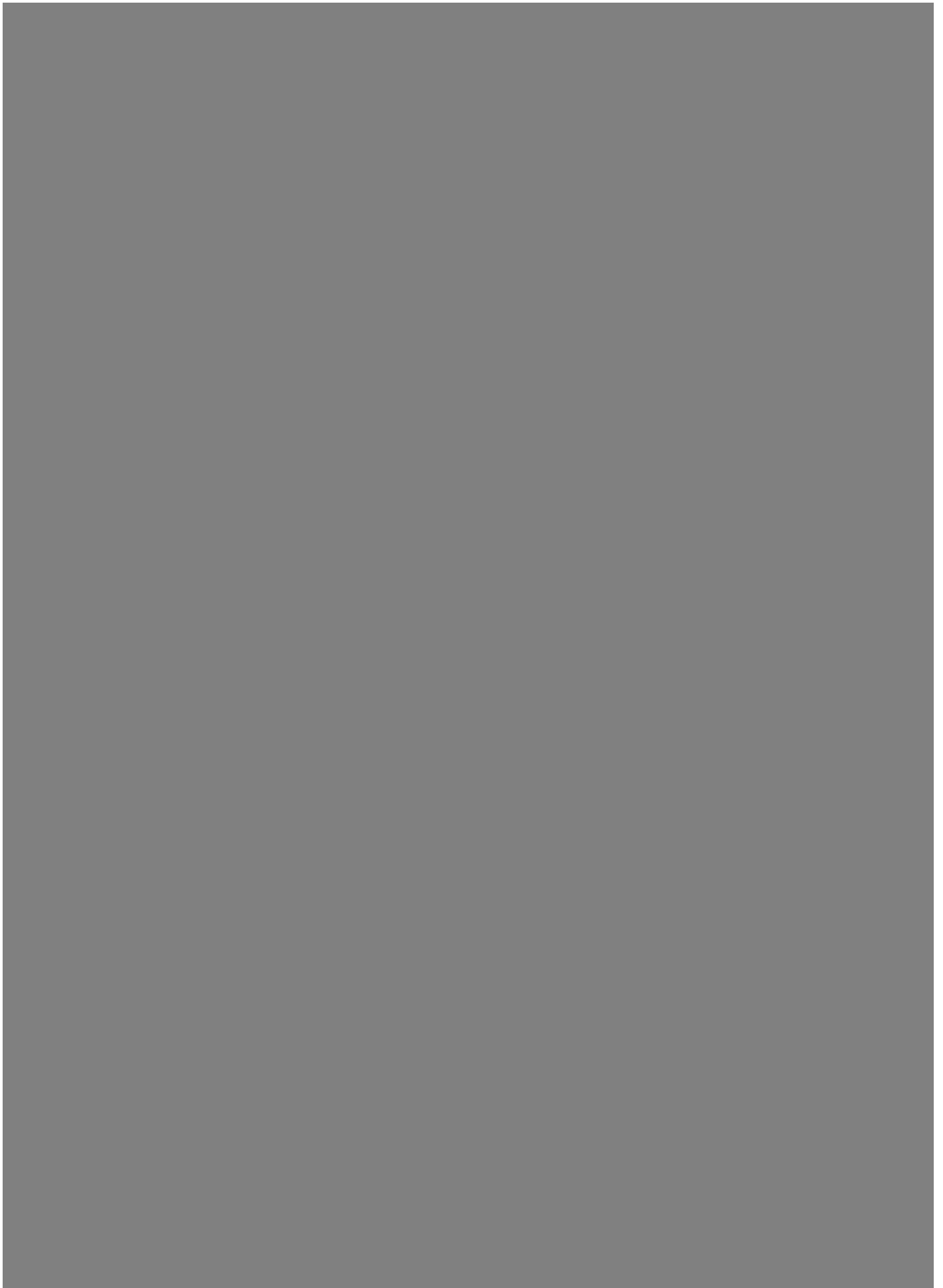

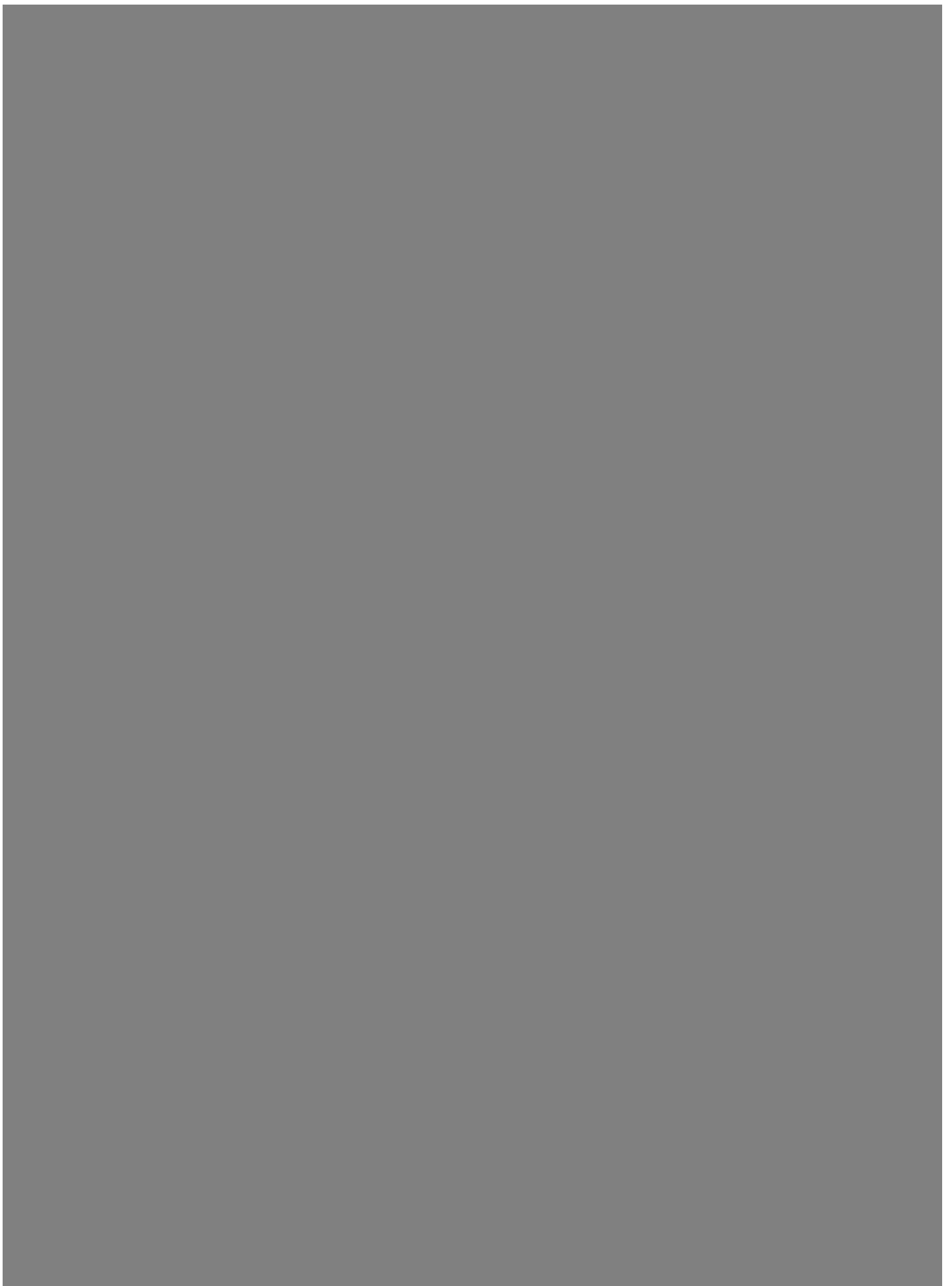





8.2 BIBLIOGRAPHY

- Abt, P., Crawford, M., Desai, N., Markmann, J., Olthoff, K., & Shaked, A. 2003. Liver transplantation from controlled non-heart-beating donors: an increased incidence of biliary complications. *Transplantation*, 75, (10) 1659-1663
- Abt, P.L., Desai, N.M., Crawford, M.D., Forman, L.M., Markmann, J.W., Olthoff, K.M., & Markmann, J.F. 2004. Survival following liver transplantation from non-heart-beating donors. *Annals of surgery*, 239, (1) 87
- Altman, K. & Greengard, O. 1966. Correlation of kynurenine excretion with liver tryptophan pyrrolase levels in disease and after hydrocortisone induction. *Journal of Clinical Investigation*, 45, (10) 1527
- Amador, A., Grande, L., Marti, J., Deulofeu, R., Miquel, R., Sol+í, A., RodriguezGÇÉLaiz, G., Ferrer, J., Fondevila, C., & Charco, R. 2007. Ischemic PreGÇÉconditioning in Deceased Donor Liver Transplantation: A Prospective Randomized Clinical Trial. *American journal of transplantation*, 7, (9) 2180-2189
- Angele, M.K., Rentsch, M., Hartl, W.H., Wittmann, B., Graeb, C., Jauch, K.W., & Loehe, F. 2008. Effect of graft steatosis on liver function and organ survival after liver transplantation. *The American Journal of Surgery*, 195, (2) 214-220
- Attia, M., Silva, M.A., & Mirza, D.F. 2008. The marginal liver donorGÇôan update. *Transplant international*, 21, (8) 713-724
- Axelrod, D.A., Schnitzler, M., Salvalaggio, P.R., Swindle, J., & Abecassis, M.M. 2007. The economic impact of the utilization of liver allografts with high donor risk index. *American Journal of Transplantation*, 7, (4) 990-997
- Azoulay, D., Castaing, D., Adam, R., Savier, E., Delvart, V.r., Karam, V., Ming, B.Y., Dannaoui, M., Krissat, J., & Bismuth, H. 2001. Split-liver transplantation for two adult recipients: feasibility and long-term outcomes. *Annals of surgery*, 233, (4) 565
- Baranski, A. 2009. *Surgical technique of the abdominal organ procurement* Springer.
- Bassanello, M., De Palo, E.F., Lancerin, F., Vitale, A., Gatti, R., Montin, U., Ciarleglio, F.A., Senzolo, M., Burra, P., & Brolese, A. 2004. Growth hormone/insulinGÇÉlike growth factor 1 axis recovery after liver transplantation: A preliminary prospective study. *Liver transplantation*, 10, (5) 692-698
- Belzer, F.O. & Southard, J.H. 1988. Principles of solid-organ preservation by cold storage. *Transplantation*, 45, (4) 673-676
- Bendorf, A., Kerridge, I.H., Kelly, P.J., Pussell, B., & Guasch, X. 2012. Explaining failure through success: a critical analysis of reduction in road and stroke deaths as an explanation for Australia's low deceased organ donation rates. *Internal medicine journal*, 42, (8) 866-873

- Benjamini, Y. & Hochberg, Y. 1995. Controlling the false discovery rate: a practical and powerful approach to multiple testing. *Journal of the Royal Statistical Society. Series B (Methodological)* 289-300
- Bismuth, H., Ericzon, B.G., Rolles, K., Castaing, D., Otte, J.B., Ringe, B., & Sloof, M. 1987. Hepatic transplantation in Europe: first report of the European Liver Transplant Registry. *The Lancet*, 330, (8560) 674-676
- Bogdanov, M., Matson, W.R., Wang, L., Matson, T., Saunders-Pullman, R., Bressman, S.S., & Beal, M.F. 2008. Metabolomic profiling to develop blood biomarkers for Parkinson's disease. *Brain*, 131, (2) 389-396
- Bohra, R., Klepacki, J., Klawitter, J., Klawitter, J., Thurman, J.M., & Christians, U. 2013. Proteomics and metabolomics in renal transplantation: Quo vadis? *Transplant International*, 26, (3) 225-241
- Bontempo, F.A., Lewis, J.H., Van Thiel, D.H., Spero, J.A., Ragni, M.V., Butler, P., Israel, L., & Starzl, T.E. 1985. The relation of preoperative coagulation findings to diagnosis, blood usage, and survival in adult liver transplantation. *Transplantation*, 39, (5) 532
- Borchert, D. H., Glanemann, M., Mogl, M., Langrehr, J., & Neuhaus, P. Adult liver transplantation using liver grafts from donors over 70 years of age, 2 edn, Elsevier, pp. 1186-1187.
- Boutillier, R.G. 2001. Mechanisms of cell survival in hypoxia and hypothermia. *Journal of Experimental Biology*, 204, (18) 3171-3181
- Brass, C.A., Narciso, J., & Gollan, J.L. 1991. Enhanced activity of the free radical producing enzyme xanthine oxidase in hypoxic rat liver. Regulation and pathophysiological significance. *Journal of Clinical Investigation*, 87, (2) 424
- Bravata, D.M., Olkin, I., Barnato, A.E., Keeffe, E.B., & Owens, D.K. 1999. Health-related quality of life after liver transplantation: A meta-analysis. *Liver Transplantation and Surgery*, 5, (4) 318-331
- Brinkkoetter, P.T., Song, H., Losel, R., Schnetzke, U., Gottmann, U., Feng, Y., Hanusch, C., Beck, G.C., Schnuelle, P., Wehling, M., van der Woude, F.J., & Yard, B.A. 2008. Hypothermic injury: the mitochondrial calcium, ATP and ROS love-hate triangle out of balance. *Cell Physiol Biochem*, 22, (1-4) 195-204 available from: PM:18769046
- Brockmann, J.G., Vaidya, A., Reddy, S., & Friend, P.J. 2006. Retrieval of abdominal organs for transplantation. *British journal of surgery*, 93, (2) 133-146
- Brockmann, J., Reddy, S., Coussios, C., Pigott, D., Guirriero, D., Hughes, D., Morovat, A., Roy, D., Winter, L., & Friend, P.J. 2009. Normothermic perfusion: a new paradigm for organ preservation. *Annals of surgery*, 250, (1) 1-6
- Brown, A.M. & Ransom, B.R. 2007. Astrocyte glycogen and brain energy metabolism. *Glia*, 55, (12) 1263-1271

- Buis, C.I., Geuken, E., Visser, D.S., Kuipers, F., Haagsma, E.B., Verkade, H.J., & Porte, R.J. 2009. Altered bile composition after liver transplantation is associated with the development of nonanastomotic biliary strictures. *Journal of hepatology*, 50, (1) 69-79
- Buis, C.I., Hoekstra, H., Verdonk, R.C., & Porte, R.J. 2006. Causes and consequences of ischemic-type biliary lesions after liver transplantation. *Journal of hepato-biliary-pancreatic surgery*, 13, (6) 517-524
- Burke, A. & Lucey, M.R. 2004. Non-Alcoholic Fatty Liver Disease, Non-Alcoholic Steatohepatitis and Orthotopic Liver Transplantation. *American Journal of Transplantation*, 4, (5) 686-693
- Busquets, J., Xiol, X., Figueras, J., Jaurrieta, E., Torras, J., Ramos, E., Rafecas, A., Fabregat, J., Lama, C., & Ibanez, L. 2001. The impact of donor age on liver transplantation: influence of donor age on early liver function and on subsequent patient and graft survival. *Transplantation*, 71, (12) 1765-1771
- Callaghan, C.J., Charman, S.C., Muiesan, P., Powell, J.J., Gimson, A.E., & van der Meulen, J.H. 2013. Outcomes of transplantation of livers from donation after circulatory death donors in the UK: a cohort study. *BMJ open*, 3, (9) e003287
- Calne, R.Y., Rolles, K., Thiru, S., McMaster, P., Craddock, G.N., Aziz, S., White, D.J.G., Evans, D.B., Dunn, D.C., & Henderson, R.G. 1979. Cyclosporin A initially as the only immunosuppressant in 34 recipients of cadaveric organs: 32 kidneys, 2 pancreases, and 2 livers. *The Lancet*, 314, (8151) 1033-1036
- Cheng, Y.F., Chen, C.L., Lai, C.Y., Chen, T.Y., Huang, T.L., Lee, T.Y., Lin, C.L., Lord, R., Chen, Y., & Eng, H.L. 2001. Assessment of Donor Fatty Livers for Liver Transplantation. *Transplantation*, 71, (9) 1221-1225
- Cieslak, B., Lewandowski, Z., Urban, M., Ziarkiewicz-Wroblewska, B., & Krawczyk, M. Microvesicular liver graft steatosis as a risk factor of initial poor function in relation to suboptimal donor parameters, 8 edn, Elsevier, pp. 2985-2988.
- Clark, J.M. 2006. The epidemiology of nonalcoholic fatty liver disease in adults. *Journal of clinical gastroenterology*, 40, S5-S10
- Clarke, W., Silverman, B.C., Zhang, Z., Chan, D.W., Klein, A.S., & Molmenti, E.P. 2003. Characterization of renal allograft rejection by urinary proteomic analysis. *Annals of surgery*, 237, (5) 660
- Clavien, P.A., Harvey, P.R., & Strasberg, S.M. 1992. Preservation and reperfusion injuries in liver allografts. *Transplantation*, 53, (5) 957-978
- Clavien, P.A., Petrowsky, H., DeOliveira, M.L., & Graf, R. 2007. Strategies for safer liver surgery and partial liver transplantation. *New England Journal of Medicine*, 356, (15) 1545-1559
- Coca, S.G., Yalavarthy, R., Concato, J., & Parikh, C.R. 2007. Biomarkers for the diagnosis and risk stratification of acute kidney injury: a systematic review. *Kidney international*, 73, (9) 1008-1016

- Cohen, B., D'Amaro, J., Meester, J.D., & Persijn, G.G. 1997. Changing patterns in organ donation in Eurotransplant, 1990-1994. *Transplant international*, 10, (1) 1-6
- Colli, A., Fraquelli, M., Casazza, G., Massironi, S., Colucci, A., Conte, D., & Duca, P. 2006. Accuracy of ultrasonography, spiral CT, magnetic resonance, and alpha-fetoprotein in diagnosing hepatocellular carcinoma: a systematic review. *The American journal of gastroenterology*, 101, (3) 513-523
- Comisarow, M.B. & Marshall, A.G. 1974. Fourier transform ion cyclotron resonance spectroscopy. *Chemical physics letters*, 25, (2) 282-283
- Cywes, R.O.B.E., Greig, P.D., Sanabria, J.R., Clavien, P.A., Levy, G.A., Harvey, P.R., & Strasberg, S.M. 1992. Effect of intraportal glucose infusion on hepatic glycogen content and degradation, and outcome of liver transplantation. *Annals of surgery*, 216, (3) 235
- D'Alessandro, A.M., Kalayoglu, M., Sollinger, H.W., Pirsch, J.D., Southard, J.H., & Belzer, F.O. 1991. Current status of organ preservation with University of Wisconsin solution. *Archives of pathology & laboratory medicine*, 115, (3) 306-310
- D'Alessandro, A.M., Hoffmann, R.M., Knechtle, S.J., Odorico, J.S., Becker, Y.T., Musat, A., Pirsch, J.D., Sollinger, H.W., & Kalayoglu, M. 2000. Liver transplantation from controlled non-heart beating donors. *Surgery*, 128, (4) 579-588
- de Vera, M.E., Lopez-Solis, R., Dvorchik, I., Campos, S., Morris, W., Demetris, A.J., Fontes, P., & Marsh, J.W. 2009. Liver transplantation using donation after cardiac death donors: long-term follow-up from a single center. *Am.J.Transplant*, 9, (4) 773-781 available from: PM:19344466
- DeCarlis, L., Sansalone, C.V., Rondinara, G.F., Colella, G., Slim, A.O., Rossetti, O., Aseni, P., Volpe, A.D., Belli, L.S., & Alberti, A. 1996. Is the use of marginal donors justified in liver transplantation? Analysis of results and proposal of modern criteria. *Transplant international*, 9, (s1) S414-S417
- Dieterle, F., Ross, A., Schlotterbeck, G., & Senn, H. 2006. Probabilistic quotient normalization as robust method to account for dilution of complex biological mixtures. Application in 1H NMR metabolomics. *Analytical Chemistry*, 78, (13) 4281-4290
- Duarte, I.F., Stanley, E.G., Holmes, E., Lindon, J.C., Gil, A.M., Tang, H., Ferdinand, R., McKee, C.G., Nicholson, J.K., & Vilca-Melendez, H. 2005. Metabolic assessment of human liver transplants from biopsy samples at the donor and recipient stages using high-resolution magic angle spinning 1H NMR spectroscopy. *Analytical chemistry*, 77, (17) 5570-5578
- Dunn, W.B. 2008. Current trends and future requirements for the mass spectrometric investigation of microbial, mammalian and plant metabolomes. *Physical biology*, 5, (1) 011001
- Dunn, W.B. & Ellis, D.I. 2005. Metabolomics: current analytical platforms and methodologies. *TrAC Trends in Analytical Chemistry*, 24, (4) 285-294
- Dutkowski, P., Odermatt, B., Heinrich, T., Schonfeld, S., Watzka, M., Winkelbach, V., Krysiak, M., & Junginger, T. 1998. Hypothermic oscillating liver perfusion stimulates ATP synthesis prior to transplantation. *J.Surg.Res.*, 80, (2) 365-372 available from: PM:9878339

- Dutkowski, P., Schlegel, A., Slankamenac, K., Oberkofler, C.E., Adam, R., Burroughs, A.K., Schadde, E., M++llhaupt, B., & Clavien, P.A. 2012. The use of fatty liver grafts in modern allocation systems: risk assessment by the balance of risk (BAR) score. *Annals of surgery*, 256, (5) 861-869
- Feng, L., Zhao, N., Yao, X., Sun, X., Du, L., Diao, X., Li, S., & Li, Y. 2007. Histidine-tryptophan-ketoglutarate solution vs. University of Wisconsin solution for liver transplantation: A systematic review. *Liver Transplantation*, 13, (8) 1125-1136
- Feng, S., Goodrich, N.P., Bragg-Gresham, J.L., Dykstra, D.M., Punch, J.D., DebRoy, M.A., Greenstein, S.M., & Merion, R.M. 2006. Characteristics associated with liver graft failure: the concept of a donor risk index. *American Journal of Transplantation*, 6, (4) 783-790
- Foley, D.P., Fernandez, L.A., Levenson, G., Anderson, M., Mezrich, J., Sollinger, H.W., & D'Alessandro, A. 2011. Biliary complications after liver transplantation from donation after cardiac death donors: an analysis of risk factors and long term outcomes from a single center. *Annals of surgery*, 253, (4) 817
- Foley, D.P., Fernandez, L.A., Levenson, G., Chin, L.T., Krieger, N., Cooper, J.T., Shames, B.D., Becker, Y.T., Odorico, J.S., & Knechtle, S.J. 2005. Donation after cardiac death: the University of Wisconsin experience with liver transplantation. *Annals of surgery*, 242, (5) 724
- Fondevila, C., Busuttill, R.W., & Kupiec-Weglinski, J.W. 2003. Hepatic ischemia/reperfusion injury: a fresh look. *Experimental and molecular pathology*, 74, (2) 86-93
- Fong, Y. & Blumgart, L.H. 2000. *Surgery of the liver and biliary tract* WB Saunders.
- Fratte, S., Gendrault, J., Steffan, A., & Kirn, A. 1991. Comparative ultrastructural study of rat livers preserved in euroGÇÉcollins or university of wisconsin solution. *Hepatology*, 13, (6) 1173-1180
- Frowein, R. A., Firsching, R., & Nanassis, K. 1989, "Diagnosis of brain death," *In Head Injuries*, Springer, pp. 237-239.
- Fukumori, T., Ohkohchi, N., Tsukamoto, S., & Satomi, S. 1999. The Mechanism of Injury in A Steatotic Liver Graft During Cold Preservation1, 2. *Transplantation*, 67, (2) 195-200
- Gok, M.A., Pelsers, M., Glatz, J.F., Shenton, B.K., Peaston, R., Cornell, C., & Talbot, D. 2003. Use of two biomarkers of renal ischemia to assess machine-perfused non-heart-beating donor kidneys. *Clinical chemistry*, 49, (1) 172-175
- Gonzalez, F.X., Rimola, A., Grande, L., Antolin, M., Garcia-Valdecasas, J.C., Fuster, J., Lacy, A.M., Cugat, E., Visa, J., & Rodes, J. 1994. Predictive factors of early postoperative graft function in human liver transplantation. *Hepatology*, 20, (3) 565-573
- Goode, H.F., Webster, N.R., Howdle, P.D., Leek, J.P., Lodge, J.P.A., Sadek, S.A., & Walker, B.E. 1994. Reperfusion injury, antioxidants and hemodynamics during orthotopic liver transplantation. *Hepatology*, 19, (2) 354-359
- Greenfield, J.R. & Campbell, L.V. 2004. Insulin resistance and obesity. *Clinics in dermatology*, 22, (4) 289-295

Guan, S., Marshall, A.G., & Scheppele, S.E. 1996. Resolution and chemical formula identification of aromatic hydrocarbons and aromatic compounds containing sulfur, nitrogen, or oxygen in petroleum distillates and refinery streams. *Analytical chemistry*, 68, (1) 46-71

Guarrera, J.V. & Karim, N.A. 2008. Liver preservation: is there anything new yet? *Current opinion in organ transplantation*, 13, (2) 148-154

Gundlach, M., Broering, D., Topp, S., Sterneck, M., & Rogiers, X. 2000. Split liver technique: Liver splitting for two adult recipients. *Liver transplantation*, 6, (6) 703-706

Hartog, H., May, C., Corbett, C., Tomlinson, J., Bramhall, S., Mergental, H., Isaac, J., Muiesan, P., Mirza, D., & Perera, T. Early Occurrence of New-Onset Diabetes After Transplant Is Related to the Type of Liver Graft and Warm Ischaemic Injury, LIPPINCOTT WILLIAMS & WILKINS 530 WALNUT ST, PHILADELPHIA, PA 19106-3621 USA, p. 173.

Heeren, R.M.A., Kleinnijenhuis, A.J., McDonnell, L.A., & Mize, T.H. 2004. A mini-review of mass spectrometry using high-performance FTICR-MS methods. *Analytical and bioanalytical chemistry*, 378, (4) 1048-1058

Heidenhain, C., Pratschke, J., Puhl, G., Neumann, U., Pascher, A., Veltzke-Schlieker, W., & Neuhaus, P. 2010. Incidence of and risk factors for ischemic-type biliary lesions following orthotopic liver transplantation. *Transplant international*, 23, (1) 14-22

Heisel, O., Heisel, R., Balshaw, R., & Keown, P. 2004. New onset diabetes mellitus in patients receiving calcineurin inhibitors: a systematic review and meta-analysis. *American Journal of Transplantation*, 4, (4) 583-595

Higdon, R., Haynes, W., Stanberry, L., Stewart, E., Yandl, G., Howard, C., Broomall, W., Kolker, N., & Kolker, E. 2013. Unraveling the complexities of life sciences data. *Big Data*, 1, (1) 42-50

Hillered, L., Valtysson, J., Enblad, P., & Persson, L. 1998. Interstitial glycerol as a marker for membrane phospholipid degradation in the acutely injured human brain. *Journal of Neurology, Neurosurgery & Psychiatry*, 64, (4) 486-491

Hogberg, N., Carlsson, P.O., Hillered, L., Meurling, S., & Stenback, A. 2012a. Intestinal ischemia measured by intraluminal microdialysis. *Scand.J.Clin.Lab Invest*, 72, (1) 59-66 available from: PM:22103734

Hogberg, N., Carlsson, P.O., Hillered, L., Stenback, A., & Lilja, H.E. 2012b. Intraluminal intestinal microdialysis detects markers of hypoxia and cell damage in experimental necrotizing enterocolitis. *J.Pediatr.Surg.*, 47, (9) 1646-1651 available from: PM:22974600

Holmgren, G., Steen, L., Suhr, O., Ericzon, B.G., Groth, C.G., Andersen, O., Wallin, B.G., Seymour, A., Richardson, S., & Hawkins, P.N. 1993. Clinical improvement and amyloid regression after liver transplantation in hereditary transthyretin amyloidosis. *The Lancet*, 341, (8853) 1113-1116

Hoofnagle, J.H., Lombardero, M., Zetterman, R.K., Lake, J., Porayko, M., Everhart, J., Belle, S.H., & Detre, K.M. 1996. Donor age and outcome of liver transplantation. *Hepatology*, 24, (1) 89-96

- Horton, R.L. & Horton, P.J. 1990. Knowledge regarding organ donation: Identifying and overcoming barriers to organ donation. *Social science & medicine*, 31, (7) 791-800
- Hoshino, T., Maley, W.R., Bulkley, G.B., & Williams, G.M. 1988. Ablation of free radical-mediated reperfusion injury for the salvage of kidneys taken from non-heartbeating donors. A quantitative evaluation of the proportion of injury caused by reperfusion following periods of warm, cold, and combined warm and cold ischemia. *Transplantation*, 45, (2) 284-289
- Hrydziuszko, O., Silva, M.A., PR Perera, M.T., Richards, D.A., Murphy, N., Mirza, D., & Viant, M.R. 2010a. Application of metabolomics to investigate the process of human orthotopic liver transplantation: a proof-of-principle study. *OMICS A Journal of Integrative Biology*, 14, (2) 143-150
- Hrydziuszko, O., Silva, M.A., PR Perera, M.T., Richards, D.A., Murphy, N., Mirza, D., & Viant, M.R. 2010b. Application of metabolomics to investigate the process of human orthotopic liver transplantation: a proof-of-principle study. *OMICS A Journal of Integrative Biology*, 14, (2) 143-150
- Hrydziuszko, O. & Viant, M.R. 2012. Missing values in mass spectrometry based metabolomics: an undervalued step in the data processing pipeline. *Metabolomics*, 8, (1) 161-174
- Ikeda, T., Yanaga, K., Kishikawa, K., Kakizoe, S., Shimada, M., & Sugimachi, K. 1992. Ischemic injury in liver transplantation: difference in injury sites between warm and cold ischemia in rats. *Hepatology*, 16, (2) 454-461
- Imber, C.J., St Peter, S.D., Handa, A., & Friend, P.J. 2002. Hepatic steatosis and its relationship to transplantation. *Liver transplantation*, 8, (5) 415-423
- Ishii, K., Suita, S., & Sumimoto, H. 1990. Effect of verapamil on conversion of xanthine dehydrogenase to oxidase in ischemic rat liver. *Research in experimental medicine*, 190, (1) 389-399
- Iwatsuki, S., Starzl, T. E., Todo, S., Gordon, R. D., Esquivel, C. O., Tzakis, A. G., Makowka, L., Marsh, J. W., Koneru, B., & Stieber, A. Experience in 1,000 liver transplants under cyclosporine-steroid therapy: a survival report, 1 Suppl 1 edn, NIH Public Access, p. 498.
- Iwatsuki, S.H.U.N., Gordon, R.D., Shaw Jr, B.W., & Starzl, T.E. 1985. Role of liver transplantation in cancer therapy. *Annals of surgery*, 202, (4) 401
- Jaeschke, H. 2003. Molecular mechanisms of hepatic ischemia-reperfusion injury and preconditioning. *American Journal of Physiology-Gastrointestinal and Liver Physiology*, 284, (1) G15-G26
- Jaeschke, H., Farhood, A., & Smith, C.W. 1990. Neutrophils contribute to ischemia/reperfusion injury in rat liver in vivo. *The FASEB Journal*, 4, (15) 3355-3359
- Jamieson, R.W., Zilvetti, M., Roy, D., Hughes, D., Morovat, A., Coussios, C.C., & Friend, P.J. 2011. Hepatic steatosis and normothermic perfusion: preliminary experiments in a porcine model. *Transplantation*, 92, (3) 289-295

Jansson, K., Ungerstedt, J., Jonsson, T., Redler, B., Andersson, M., Ungerstedt, U., & Norgren, L. 2009. Human intraperitoneal microdialysis: increased lactate/pyruvate ratio suggests early visceral ischaemia.

Junot, C., Madalinski, G., Tabet, J.C., & Ezan, E. 2010. Fourier transform mass spectrometry for metabolome analysis. *Analyst*, 135, (9) 2203-2219

Kaddurah-Daouk, R. & Krishnan, K.R.R. 2008. Metabolomics: a global biochemical approach to the study of central nervous system diseases. *Neuropsychopharmacology*, 34, (1) 173-186

Kanda, H., Tateya, S., Tamori, Y., Kotani, K., Hiasa, K.i., Kitazawa, R., Kitazawa, S., Miyachi, H., Maeda, S., & Egashira, K. 2006. MCP-1 contributes to macrophage infiltration into adipose tissue, insulin resistance, and hepatic steatosis in obesity. *The Journal of clinical investigation*, 116, (6) 1494-1505

Kanehisa, M. 2002. The KEGG database. *silico simulation of biological processes*, 247, 91-103

Kanehisa, M. & Goto, S. 2000. KEGG: kyoto encyclopedia of genes and genomes. *Nucleic acids research*, 28, (1) 27-30

Kanehisa, M., Goto, S., Hattori, M., Aoki-Kinoshita, K.F., Itoh, M., Kawashima, S., Katayama, T., Araki, M., & Hirakawa, M. 2006. From genomics to chemical genomics: new developments in KEGG. *Nucleic acids research*, 34, (suppl 1) D354-D357

Kaste, M., Hillbom, M., & Palo, J. 1979. Diagnosis and management of brain death. *British medical journal*, 1, (6162) 525

Kim, W., Therneau, T.M., Benson, J.T., Kremers, W.K., Rosen, C.B., Gores, G.J., & Dickson, E.R. 2006. Deaths on the liver transplant waiting list: an analysis of competing risks. *Hepatology*, 43, (2) 345-351

Knox, W.E. 1951. Two mechanisms which increase in vivo the liver tryptophan peroxidase activity: specific enzyme adaptation and stimulation of the pituitary-adrenal system. *British journal of experimental pathology*, 32, (5) 462

Knox, W.E. & Mehler, A.H. 1950. The conversion of tryptophan to kynurenine in liver I. The coupled tryptophan peroxidase-oxidase system forming formylkynurenine. *Journal of Biological Chemistry*, 187, (1) 419-430

Koal, T. & Deigner, H.P. 2010. Challenges in mass spectrometry based targeted metabolomics. *Current molecular medicine*, 10, (2) 216-226

Koffron, A. & Stein, J.A. 2008. Liver transplantation: indications, pretransplant evaluation, surgery, and posttransplant complications. *Medical Clinics of North America*, 92, (4) 861-888

Kolker, E., Higdon, R., Haynes, W., Welch, D., Broomall, W., Lancet, D., Stanberry, L., & Kolker, N. 2012. MOPED: model organism protein expression database. *Nucleic acids research*, 40, (D1) D1093-D1099

Kompanje, E.J., de Groot, Y.J., & Bakker, J. 2011. Is organ donation from brain dead donors reaching an inescapable and desirable nadir? *Transplantation*, 91, (11) 1177-1180

- Koneru, B. & Dikdan, G. 2002. Hepatic steatosis and liver transplantation current clinical and experimental perspectives. *Transplantation*, 73, (3) 325-330
- Koning, O.H., Ploeg, R.J., Van Bockel, J.H., Groenewegen, M., van der Woude, F.J., Persijn, G.G., & Hermans, J. 1997. Risk factors for delayed graft function in cadaveric kidney transplantation: a prospective study of renal function and graft survival after preservation with University of Wisconsin solution in multi-organ donors. European Multicenter Study Group. *Transplantation*, 63, (11) 1620-1628
- Kootstra, G. 1997. The asystolic, or non-heartbeating, donor. *Transplantation*, 63, (7) 917-921
- Kukan, M. & Haddad, P.S. 2001. Role of hepatocytes and bile duct cells in preservation reperfusion injury of liver grafts. *Liver transplantation*, 7, (5) 381-400
- Kuo, H.T., Sampaio, M.S., Ye, X., Reddy, P., Martin, P., & Bunnapradist, S. 2010. Risk factors for new-onset diabetes mellitus in adult liver transplant recipients, an analysis of the Organ Procurement and Transplant Network/United Network for Organ Sharing database. *Transplantation*, 89, (9) 1134-1140
- Leithead, J.A., Tariciotti, L., Gunson, B., Holt, A., Isaac, J., Mirza, D.F., Bramhall, S., Ferguson, J.W., & Muiesan, P. 2012. Donation after cardiac death liver transplant recipients have an increased frequency of acute kidney injury. *American Journal of Transplantation*, 12, (4) 965-975
- Lemasters, J.J., Nieminen, A.L., Qian, T., Trost, L.C., Elmore, S.P., Nishimura, Y., Crowe, R.A., Cascio, W.E., Bradham, C.A., & Brenner, D.A. 1998. The mitochondrial permeability transition in cell death: a common mechanism in necrosis, apoptosis and autophagy. *Biochimica et Biophysica Acta (BBA)-Bioenergetics*, 1366, (1) 177-196
- Maheshwari, A., Maley, W., Li, Z., & Thuluvath, P.J. 2007. Biliary complications and outcomes of liver transplantation from donors after cardiac death. *Liver transplantation*, 13, (12) 1645-1653
- Makowka, L., Gordon, R. D., Todo, S., Ohkohchi, N., Marsh, J. W., Tzakis, A. G., Yokoi, H., Ligush, J., Esquivel, C. O., & Satake, M. Analysis of donor criteria for the prediction of outcome in clinical liver transplantation, 1 Pt 3 edn, NIH Public Access, p. 2378.
- Mangus, R.S., Tector, A.J., Agarwal, A., Vianna, R., Murdock, P., & Fridell, J.A. 2006. Comparison of histidine-tryptophan-ketoglutarate solution (HTK) and University of Wisconsin solution (UW) in adult liver transplantation. *Liver transplantation*, 12, (2) 226-230
- Marchesini, G., Brizi, M., Morselli-Labate, A.M., Bianchi, G., Bugianesi, E., McCullough, A.J., Forlani, G., & Melchionda, N. 1999. Association of nonalcoholic fatty liver disease with insulin resistance. *The American journal of medicine*, 107, (5) 450-455
- Marino, I.R., Doyle, H.R., Aldrighetti, L., Doria, C., McMichael, J., Gayowski, T., Fung, J.J., Tzakis, A.G., & Starzl, T.E. 1995. Effect of donor age and sex on the outcome of liver transplantation. *Hepatology*, 22, (6) 1754-1762
- Markmann, J.F., Markmann, J.W., Markmann, D.A., Bacquerizo, A., Singer, J., Holt, C.D., Gornbein, J., Yersiz, H., Morrissey, M., & Lerner, S.M. 2001. Preoperative factors associated

with outcome and their impact on resource use in 1148 consecutive primary liver transplants. *Transplantation*, 72, (6) 1113-1122

Marshall, A.G., Hendrickson, C.L., & Jackson, G.S. 1998. Fourier transform ion cyclotron resonance mass spectrometry: a primer. *Mass spectrometry reviews*, 17, (1) 1-35

Marsman, W.A., Wiesner, R.H., Rodriguez, L., Batts, K.P., Porayko, M.K., Hay, J.E., Gores, G.J., & Krom, R.A. 1996. Use of fatty donor liver is associated with diminished early patient and graft survival. *Transplantation*, 62, (9) 1246-1251

Mateo, R., Cho, Y., Singh, G., Stapfer, M., Donovan, J., Kahn, J., Fong, T., Sher, L., Jabbour, N., & Aswad, S. 2006. Risk factors for graft survival after liver transplantation from donation after cardiac death donors: an analysis of OPTN/UNOS data. *American Journal of Transplantation*, 6, (4) 791-796

Mato, J.M. & Lu, S.C. 2007. Role of S-adenosyl-methionine in liver health and injury. *Hepatology*, 45, (5) 1306-1312

Mazzaferro, V., Chun, Y.S., Poon, R.T., Schwartz, M.E., Yao, F.Y., Marsh, J.W., Bhoori, S., & Lee, S.G. 2008. Liver transplantation for hepatocellular carcinoma. *Annals of surgical oncology*, 15, (4) 1001-1007

McCormack, L., Petrowsky, H., Jochum, W., Mullhaupt, B., Weber, M., & Clavien, P.A. 2007. Use of severely steatotic grafts in liver transplantation: a matched case-control study. *Annals of surgery*, 246, (6) 940-948

McLaren, A.J. & Friend, P.J. 2003. Trends in organ preservation. *Transplant international*, 16, (10) 701-708

Mehler, A.H. & Knox, W.E. 1950. The conversion of tryptophan to kynurenine in liver II. The enzymatic hydrolysis of formylkynurenine. *Journal of Biological Chemistry*, 187, (1) 431-438

Mellor, A.L. & Munn, D.H. 2004. IDO expression by dendritic cells: tolerance and tryptophan catabolism. *Nature Reviews Immunology*, 4, (10) 762-774

Minor, T., Saad, S., Nagelschmidt, M., Kötting, M., Fu, Z., Paul, A., & Isselhard, W. 1998. Successful Transplantation of Porcine Livers After Warm Ischemic Insult in Situ and Cold Preservation Including Postconditioning With Gaseous Oxygen. *Transplantation*, 65, (9) 1262-1264

Mirza, D.F., Gunson, B.K., Da Silva, R., Mayer, A.D., Buckels, J.A.C., & McMaster, P. 1994. Policies in Europe on "marginal quality" donor livers. *The Lancet*, 344, (8935) 1480-1483

Moers, C., Leuvenink, H.G., & Ploeg, R.J. 2007. Non-heart beating organ donation: overview and future perspectives. *Transplant international*, 20, (7) 567-575

Monbaliu, D., Libbrecht, L., De, V.R., Vekemans, K., Walter, H., Liu, Q., Heedfeld, V., Goossens, V., Pirenne, J., & Roskams, T. 2008. The extent of vacuolation in non-heart-beating porcine donor liver grafts prior to transplantation predicts their viability. *Liver Transpl.*, 14, (9) 1256-1265 available from: PM:18756467

- Monbaliu, D., Pirenne, J., & Talbot, D. 2012. Liver transplantation using donation after cardiac death donors. *Journal of hepatology*, 56, (2) 474-485
- Muiesan, P., Girlanda, R., Jassem, W., Melendez, H.V., O'Grady, J., Bowles, M., Rela, M., & Heaton, N. 2005. Single-center experience with liver transplantation from controlled non-heartbeating donors: a viable source of grafts. *Annals of surgery*, 242, (5) 732
- Munshi, M.K., Priester, S., Gaudio, E., Yang, F., Alpini, G., Mancinelli, R., Wise, C., Meng, F., Franchitto, A., & Onori, P. 2011. Regulation of biliary proliferation by neuroendocrine factors: implications for the pathogenesis of cholestatic liver diseases. *The American journal of pathology*, 178, (2) 472-484
- Neuberger, J. 2004. Developments in liver transplantation. *Gut*, 53, (5) 759-768
- Neuberger, J.M. 1989. Transplantation for alcoholic liver disease. *BMJ: British Medical Journal*, 299, (6701) 693
- Newsholme, E.A. & Leech, A.R. 1983. *Biochemistry for the medical sciences*, 952 ed. Wiley Chichester.
- Nilsson, O.G., Brandt, L., Ungerstedt, U., & Saveland, H. 1999. Bedside detection of brain ischemia using intracerebral microdialysis: subarachnoid hemorrhage and delayed ischemic deterioration. *Neurosurgery*, 45, (5) 1176
- Nowak, G., Ungerstedt, J., Wernerman, J., Ungerstedt, U., & Ericzon, B.G. 2002a. Metabolic changes in the liver graft monitored continuously with microdialysis during liver transplantation in a pig model. *Liver Transpl.*, 8, (5) 424-432 available from: PM:12004341
- Nowak, G., Ungerstedt, J., Wernerman, J., Ungerstedt, U., & Ericzon, B. 2002b. Clinical experience in continuous graft monitoring with microdialysis early after liver transplantation. *British journal of surgery*, 89, (9) 1169-1175
- Nowak, G., Ungerstedt, J., Wernerman, J., Ungerstedt, U., & Ericzon, B. 2002c. Metabolic changes in the liver graft monitored continuously with microdialysis during liver transplantation in a pig model. *Liver transplantation*, 8, (5) 424-432
- Nowak, G., Ungerstedt, J., Wernerson, A., Ungerstedt, U., & Ericzon, B. 2003a. Hepatic cell membrane damage during cold preservation sensitizes liver grafts to rewarming injury. *Journal of hepato-biliary-pancreatic surgery*, 10, (3) 200-205
- Nowak, G., Ungerstedt, J., Wernerson, A., Ungerstedt, U., & Ericzon, B. 2003b. Hepatic cell membrane damage during cold preservation sensitizes liver grafts to rewarming injury. *Journal of hepato-biliary-pancreatic surgery*, 10, (3) 200-205
- O'Grady, J.G., Wendon, J., Tan, K.C., Potter, D., Cottam, S., Cohen, A.T., Gimson, A.E., & Williams, R. 1991. Liver transplantation after paracetamol overdose. *BMJ: British Medical Journal*, 303, (6796) 221
- Ohta, D., Kanaya, S., & Suzuki, H. 2010. Application of Fourier-transform ion cyclotron resonance mass spectrometry to metabolic profiling and metabolite identification. *Current opinion in biotechnology*, 21, (1) 35-44

- Onori, P., Alvaro, D., Floreani, A., Mancino, M., Franchitto, A., Guido, M., Carpino, G., De Santis, A., Angelico, M., & Attili, A.F. 2007. Activation of the IGF1 system characterizes cholangiocyte survival during progression of primary biliary cirrhosis. *Journal of Histochemistry & Cytochemistry*, 55, (4) 327-334
- Park, G. 2004. Supply and demand of organs for donation. *Intensive care medicine*, 30, (1) 7-9
- Parsons, H.M., Ludwig, C., Gunther, U.L., & Viant, M.R. 2007. Improved classification accuracy in 1-and 2-dimensional NMR metabolomics data using the variance stabilising generalised logarithm transformation. *BMC bioinformatics*, 8, (1) 234
- Payne, T.G., Southam, A.D., Arvanitis, T.N., & Viant, M.R. 2009. A signal filtering method for improved quantification and noise discrimination in fourier transform ion cyclotron resonance mass spectrometry-based metabolomics data. *J.Am.Soc.Mass Spectrom.*, 20, (6) 1087-1095 available from: PM:19269189
- Perera, M.T., Higdon, R., Richards, D.A., Silva, M.A., Murphy, N., Kolker, E., & Mirza, D.F. 2014a. Biomarker differences between cadaveric grafts used in human orthotopic liver transplantation as identified by coulometric electrochemical array detection (CEAD) metabolomics. *OMICS*, 18, (12) 767-777 available from: PM:25353146
- Perera, M.T.P.R., Richards, D.A., Silva, M.A., Ahmed, N., Neil, D.A., Murphy, N., & Mirza, D.F. 2014b. Comparison of energy metabolism in liver grafts from donors after circulatory death and donors after brain death during cold storage and reperfusion. *British Journal of Surgery*
- Perez-Daga, J. A., Santoyo, J., Suarez, M. A., Fernandez-Aguilar, J. A., Ramirez, C., Rodriguez-Canete, A., Aranda, J. M., Sánchez-Pérez, B., Montiel, C., & Palomo, D. Influence of degree of hepatic steatosis on graft function and postoperative complications of liver transplantation, 8 edn, Elsevier, pp. 2468-2470.
- Picardi, A., D'Avola, D., Gentilucci, U.V., Galati, G., Fiori, E., Spataro, S., & Afeltra, A. 2006. Diabetes in chronic liver disease: from old concepts to new evidence. *Diabetes/metabolism research and reviews*, 22, (4) 274-283
- Ploeg, R.J., D'Alessandro, A.M., Knechtle, S.J., Stegall, M.D., Pirsch, J.D., Hoffmann, R.M., Sasaki, T., Sollinger, H.W., Belzer, F.O., & Kalayoglu, M.U.N.C. 1993. Risk factors for primary dysfunction after liver transplantation--a multivariate analysis. *Transplantation*, 55, (4) 807-813
- Pokorny, H., Gruenberger, T., Soliman, T., Rockenschaub, S., Langle, F., & Steininger, R. 2000. Organ survival after primary dysfunction of liver grafts in clinical orthotopic liver transplantation. *Transplant international*, 13, (1) S154-S157
- Reddy, S., Greenwood, J., Maniakin, N., Bhattacharjya, S., Zilvetti, M., Brockmann, J., James, T., Pigott, D., & Friend, P. 2005. Non-heart beating donor porcine livers: The adverse effect of cooling. *Liver transplantation*, 11, (1) 35-38
- Reich, D.J., Mulligan, D.C., Abt, P.L., Pruett, T.L., Abecassis, M.M.I., D'alessandro, A., Pomfret, E.A., Freeman, R.B., Markmann, J.F., & Hanto, D.W. 2009. ASTS recommended practice guidelines for controlled donation after cardiac death organ procurement and transplantation. *American Journal of Transplantation*, 9, (9) 2004-2011

- Reich, D.J., Munoz, S.J., Rothstein, K.D., Nathan, H.M., Edwards, J.M., Hasz, R.D., & Manzarbeitia, C.Y. 2000. Controlled non-heart-beating donor liver transplantation: a successful single center experience, with topic update. *Transplantation*, 70, (8) 1159-1166
- Ridley, S., Bonner, S., Bray, K., Falvey, S., Mackay, J., & Manara, A. 2005. UK guidance for non-heart-beating donation. *British journal of anaesthesia*, 95, (5) 592-595
- Rolinski, S., Horn, H., Petzoldt, T., & Paul, L. 2007. Identifying cardinal dates in phytoplankton time series to enable the analysis of long-term trends. *Oecologia*, 153, (4) 997-1008
- Rossouw, J.E., Labadarios, D., Davis, M., & Williams, R. 1977. The degradation of tryptophan in severe liver disease. *International journal for vitamin and nutrition research. Internationale Zeitschrift für Vitamin-und Ernährungsforschung. Journal international de vitaminologie et de nutrition*, 48, (3) 281-289
- Rozen, S., Cudkowicz, M.E., Bogdanov, M., Matson, W.R., Kristal, B.S., Beecher, C., Harrison, S., Vouros, P., Flarakos, J., & Vigneau-Callahan, K. 2005. Metabolomic analysis and signatures in motor neuron disease. *Metabolomics*, 1, (2) 101-108
- Rull, R., Garcia Valdecasas, J.C., Grande, L.U.I.S., Fuster, J., Lacy, A.M., Gonz+ílez, F.X., Rimola, A., Navasa, M., Iglesias, C., & Visa, J. 2001. Intrahepatic biliary lesions after orthotopic liver transplantation. *Transplant international*, 14, (3) 129-134
- Salizzoni, M., Franchello, A., Zamboni, F., Ricchiuti, A., Cocchis, D., Fop, F., Brunati, A., & Cerutti, E. 2003. Marginal grafts: finding the correct treatment for fatty livers. *Transplant international*, 16, (7) 486-493
- Saudubray, J.M., Touati, G., Delonlay, P., Jouvét, P., Narcy, C., Laurent, J., Rabier, D., Kamoun, P., Jan, D., & Revillon, Y. 1999. Liver transplantation in urea cycle disorders. *European journal of pediatrics*, 158, (2) S055-S059
- Schaubel, D.E., Sima, C.S., Goodrich, N.P., Feng, S., & Merion, R.M. 2008. The survival benefit of deceased donor liver transplantation as a function of candidate disease severity and donor quality. *American Journal of Transplantation*, 8, (2) 419-425
- Schemmer, P., Enomoto, N., Bradford, B.U., Bunzendahl, H., Raleigh, J.A., Lemasters, J.J., & Thurman, R.G. 2001. Activated Kupffer cells cause a hypermetabolic state after gentle in situ manipulation of liver in rats. *American Journal of Physiology-Gastrointestinal and Liver Physiology*, 280, (6) G1076-G1082
- Schemmer, P., Mehrabi, A., Friess, H., Sauer, P., Schmidt, J., B++chler, M.W., & Kraus, T.W. 2005. Living related liver transplantation: the ultimate technique to expand the donor pool? *Transplantation*, 80, (1S) S138-S141
- Schmid, D.G., Grosche, P., Bandel, H., & nther Jung, G. 2000. FTICR-mass spectrometry for high-resolution analysis in combinatorial chemistry. *BIOTECHNOLOGY AND BIOENGINEERING (COMBINATORIAL CHEMISTRY)*, 71, (2) 2001
- Serkova, N.J., Zhang, Y., Coatney, J.L., Hunter, L., Wachs, M.E., Niemann, C.U., & Mandell, M.S. 2007. Early detection of graft failure using the blood metabolic profile of a liver recipient. *Transplantation*, 83, (4) 517-521 available from: PM:17318087

- Serracino-Inglott, F., Habib, N.A., & Mathie, R.T. 2001. Hepatic ischemia-reperfusion injury. *The American Journal of Surgery*, 181, (2) 160-166
- Shaw Jr, B.W., Martin, D.J., Marquez, J.M., Kang, Y.G., Bugbee Jr, A.C., Iwatsuki, S.H.U.N., Griffith, B.P., Hardesty, R.L., Bahnson, H.T., & Starzl, T.E. 1984. Venous bypass in clinical liver transplantation. *Annals of surgery*, 200, (4) 524
- Sidransky, H.T. 1985. Unique actions by an essential amino acid. Marcel Dekker, New York 1-62
- Silva, M.A., Mirza, D.F., Buckels, J.A., Bramhall, S.R., Mayer, D., Wigmore, S.J., Murphy, N., & Richards, D.A. 2006a. Arginine and urea metabolism in the liver graft: A study using microdialysis in human orthotopic liver transplantation. *Transplantation*, 82, (10) 1304-1311
- Silva, M.A., Mirza, D.F., Murphy, N., Richards, D.A., Reynolds, G.M., Wigmore, S.J., & Neil, D.A. 2008. Intrahepatic complement activation, sinusoidal endothelial injury, and lactic acidosis are associated with initial poor function of the liver after transplantation. *Transplantation*, 85, (5) 718-725
- Silva, M.A., Murphy, N., Richards, D.A., Wigmore, S.J., Bramhall, S.R., Buckels, J.A., Adams, D.H., & Mirza, D.F. 2006b. Interstitial lactic acidosis in the graft during organ harvest, cold storage, and reperfusion of human liver allografts predicts subsequent ischemia reperfusion injury. *Transplantation*, 82, (2) 227-233
- Silva, M.A., Richards, D.A., Bramhall, S.R., Adams, D.H., Mirza, D.F., & Murphy, N. 2005. A study of the metabolites of ischemia-reperfusion injury and selected amino acids in the liver using microdialysis during transplantation. *Transplantation*, 79, (7) 828-835
- Smyth, G.K. 2004. Linear models and empirical bayes methods for assessing differential expression in microarray experiments. *Statistical applications in genetics and molecular biology*, 3, (1)
- Southam, A.D., Payne, T.G., Cooper, H.J., Arvanitis, T.N., & Viant, M.R. 2007. Dynamic range and mass accuracy of wide-scan direct infusion nanoelectrospray fourier transform ion cyclotron resonance mass spectrometry-based metabolomics increased by the spectral stitching method. *Anal.Chem.*, 79, (12) 4595-4602 available from: PM:17511421
- Southard, J.H. 1999. Organ preservation. *Organ procurement and preservation.Landes Bioscience, Austin* 63-79
- St Peter, S.D., Imber, C.J., & Friend, P.J. 2002. Liver and kidney preservation by perfusion. *The Lancet*, 359, (9306) 604-613
- Starzl, T. E., Iwatsuki, S., Esquivel, C. O., Todo, S., Kam, I., Lynch, S., Gordon, R. D., & Shaw Jr, B. W. Refinements in the surgical technique of liver transplantation, 4 edn, NIH Public Access, p. 349.
- Starzl, T.E., Koep, L.J., Halgrimson, C.G., Hood, J., Schroter, G.P., Porter, K.A., & Weil III, R.I.C.H. 1979. Fifteen years of clinical liver transplantation. *Gastroenterology*, 77, (2) 375

- Starzl, T.E., Porter, K.A., & Putnam, C.W. 1976. Insulin, glucagon, and the control of hepatic structure, function, and capacity for regeneration. *Metabolism*, 25, (11) 1429-1434
- Straatsburg, I.H., Abrahamse, S.L., Song, S.W., Hartman, R.J., & van Gulik, T.M. 2002. Evaluation of rat liver apoptotic and necrotic cell death after cold storage using UW, HTK, and Celsior. *Transplantation*, 74, (4) 458-464
- Strasberg, S.M., Howard, T.K., Molmenti, E.P., & Hertl, M. 1994. Selecting the donor liver: risk factors for poor function after orthotopic liver transplantation. *Hepatology*, 20, (4) 829-838
- Sumida, Y., Yonei, Y., Tanaka, S., Mori, K., Kanemasa, K., Imai, S., Taketani, H., Hara, T., Seko, Y., & Ishiba, H. 2014. Lower levels of insulin-like growth factor1 standard deviation score are associated with histological severity of nonalcoholic fatty liver disease. *Hepatology Research*
- Summers, D.M., Counter, C., Johnson, R.J., Murphy, P.G., Neuberger, J.M., & Bradley, J.A. 2010. Is the increase in DCD organ donors in the United Kingdom contributing to a decline in DBD donors? *Transplantation*, 90, (12) 1506-1510
- Takada, Y., Taniguchi, H., Fukunaga, K., Yuzawa, K., Otsuka, M., Todoroki, T., Iijima, T., & Fukao, K. 1997. Hepatic allograft procurement from non-heart-beating donors: limits of warm ischemia in porcine liver transplantatio. *Transplantation*, 63, (3) 369-373
- Tanaka, K., Uemoto, S., Tokunaga, Y., Fujita, S., Sano, K., Nishizawa, T., Sawada, H., Shirahase, I., Kim, H.J., & Yamaoka, Y. 1993. Surgical techniques and innovations in living related liver transplantation. *Annals of surgery*, 217, (1) 82
- Taylor, M.W. & Feng, G.S. 1991. Relationship between interferon-gamma, indoleamine 2, 3-dioxygenase, and tryptophan catabolism. *The FASEB Journal*, 5, (11) 2516-2522
- Taylor, N.S., Weber, R.J., Southam, A.D., Payne, T.G., Hrydziuszko, O., Arvanitis, T.N., & Viant, M.R. 2009. A new approach to toxicity testing in *Daphnia magna*: application of high throughput FT-ICR mass spectrometry metabolomics. *Metabolomics*, 5, (1) 44-58
- TE STARZL, T.L., Von Kaulla, K.N., Hermann, G., Brittain, R.S., & Waddell, W.R. 1963. Homotransplantation of the liver in humans. *Surgery, gynecology & obstetrics*, 117, 659
- Tekin, K., Imber, C.J., Atli, M., Gunson, B.K., Bramhall, S.R., Mayer, D., Buckels, J.A., McMaster, P., & Mirza, D.F. 2004. A simple scoring system to evaluate the effects of cold ischemia on marginal liver donors¹. *Transplantation*, 77, (3) 411-416
- Terness, P., Bauer, T.M., Rose, L., Dufter, C., Watzlik, A., Simon, H., & Opelz, G. 2002. Inhibition of allogeneic T cell proliferation by indoleamine 2,3-dioxygenase-expressing dendritic cells: mediation of suppression by tryptophan metabolites. *J.Exp.Med.*, 196, (4) 447-457 available from: PM:12186837
- Todo, S., Demetris, A.J., Makowka, L., Teperman, L., Podesta, L., Shaver, T., Tzakis, A., & Starzl, T.E. 1989. Primary nonfunction of hepatic allografts with preexisting fatty infiltration. *Transplantation*, 47, (5) 903
- Todo, S., Fung, J.J., Starzl, T.E., Tzakis, A.N.D.R., Demetris, A.J., Kormos, R.O.B.E., Jain, A.S.H.O., Alessiani, M.A.R.I., Takaya, S.H.U.N., & Shapiro, R. 1990. Liver, kidney, and thoracic organ transplantation under FK 506. *Annals of surgery*, 212, (3) 295

- Truog, R.D. & Robinson, W.M. 2003. Role of brain death and the dead-donor rule in the ethics of organ transplantation. *Critical care medicine*, 31, (9) 2391-2396
- Urena, M.A.G.a., Ruiz-Delgado, F.C., Gonzalez, E.M., Romero, C.J.n., Garcia, I.G.a., Segurola, C.L., Gonzalez-Pinto, I., & Sanz, R.n.G.m. 1998. Hepatic steatosis in liver transplant donors: common feature of donor population? *World journal of surgery*, 22, (8) 837-844
- Vajdova, K., Graf, R., & Clavien, P.A. 2002. ATP-supplies in the cold-preserved liver: A long-neglected factor of organ viability. *Hepatology*, 36, (6) 1543-1552 available from: PM:12447882
- Vajdova, K., Smrekova, R., Mislanova, C., Kukan, M., & Lutterova, M. 2000. Cold-preservation-induced sensitivity of rat hepatocyte function to rewarming injury and its prevention by short-term reperfusion. *Hepatology*, 32, (2) 289-296 available from: PM:10915735
- Veith, F.J., Fein, J.M., Tendler, M.D., Veatch, R.M., Kleiman, M.A., & Kalkines, G. 1977. Brain death: I. A status report of medical and ethical considerations. *Jama*, 238, (15) 1651-1655
- Verran, D., Kusyk, T., Painter, D., Fisher, J., Koorey, D., Strasser, S., Stewart, G., & McCaughan, G. 2003. Clinical experience gained from the use of 120 steatotic donor livers for orthotopic liver transplantation. *Liver transplantation*, 9, (5) 500-505
- Villeneuve, J., Lepreux, S., Mulot, A., Berard, A.M., Higa-Nishiyama, A., Costet, P., De Ledinghen, V., Bioulac-Sage, P., Balabaud, C., & Nurden, A.T. 2010. A protective role for CD154 in hepatic steatosis in mice. *Hepatology*, 52, (6) 1968-1979
- Vogel, T., Brockmann, J.G., & Friend, P.J. 2010. Ex-vivo normothermic liver perfusion: an update. *Current opinion in organ transplantation*, 15, (2) 167-172
- Vollmar, B., Glasz, J., Leiderer, R., Post, S., & Menger, M.D. 1994. Hepatic microcirculatory perfusion failure is a determinant of liver dysfunction in warm ischemia-reperfusion. *The American journal of pathology*, 145, (6) 1421
- Wall, W.J., Mimeault, R., Grant, D.R., & Bloch, M. 1990. The use of older donor livers for hepatic transplantation. *Transplantation*, 49, (2) 377-381
- Watts, R.W., Morgan, S.H., Danpure, C.J., Purkiss, P., Calne, R.Y., Rolles, K., Baker, L.R., Mansell, M.A., Smith, L.H., & Merion, R.M. 1991. Combined hepatic and renal transplantation in primary hyperoxaluria type I: clinical report of nine cases. *The American journal of medicine*, 90, (2) 179-188
- Weber, M.M., Auernhammer, C.J., Lee, P.D., Engelhardt, D., & Zachoval, R. 2002. Insulin-like growth factors and insulin-like growth factor binding proteins in adult patients with severe liver disease before and after orthotopic liver transplantation. *Hormone Research in Paediatrics*, 57, (3-4) 105-112
- Weber, R.J. & Viant, M.R. 2010. MI-Pack: Increased confidence of metabolite identification in mass spectra by integrating accurate masses and metabolic pathways. *Chemometrics and Intelligent Laboratory Systems*, 104, (1) 75-82

- Wiesner, R.H. 1998. A long-term comparison of tacrolimus (FK506) versus cyclosporine in liver transplantation: a report of the United States FK506 Study Group. *Transplantation*, 66, (4) 493-499
- Wilczek, H.E., Larsson, M., Yamamoto, S., & Ericzon, B. 2008. Domino liver transplantation. *Journal of hepato-biliary-pancreatic surgery*, 15, (2) 139-148
- Williams, C.D., Stengel, J., Asike, M.I., Torres, D.M., Shaw, J., Contreras, M., Landt, C.L., & Harrison, S.A. 2011. Prevalence of nonalcoholic fatty liver disease and nonalcoholic steatohepatitis among a largely middle-aged population utilizing ultrasound and liver biopsy: a prospective study. *Gastroenterology*, 140, (1) 124-131
- Wishart, D.S. 2005a. Metabolomics: the principles and potential applications to transplantation. *American journal of transplantation*, 5, (12) 2814-2820
- Wishart, D.S. 2005b. Metabolomics: the principles and potential applications to transplantation. *American journal of transplantation*, 5, (12) 2814-2820
- Wishart, D.S. 2008. Quantitative metabolomics using NMR. *TrAC Trends in Analytical Chemistry*, 27, (3) 228-237
- Wu, H., Southam, A.D., Hines, A., & Viant, M.R. 2008. High-throughput tissue extraction protocol for NMR-and MS-based metabolomics. *Analytical biochemistry*, 372, (2) 204-212
- Yang, J., Hutchinson, I.I., Shah, T., & Min, D.I. 2011. Genetic and clinical risk factors of new-onset diabetes after transplantation in Hispanic kidney transplant recipients. *Transplantation*, 91, (10) 1114-1119
- Yates, C.J., Furlanos, S., Hjelmessaeth, J., Colman, P.G., & Cohney, S.J. 2012. New-Onset Diabetes After Kidney Transplantation: Changes and Challenges. *American Journal of Transplantation*, 12, (4) 820-828
- Yoglu, M., Stratta, R., Hoffmann, R., Sollinger, H., D'Alessandro, A., Pirsch, J., & Belzer, F. 1988. Extended preservation of the liver for clinical transplantation. *The Lancet*, 331, (8586) 617-619
- Yoo, H.Y., Molmenti, E., & Thuluvath, P.J. 2003. The effect of donor body mass index on primary graft nonfunction, retransplantation rate, and early graft and patient survival after liver transplantation. *Liver transplantation*, 9, (1) 72-78
- Young, S.N. 1981. Mechanism of decline in rat brain 5-hydroxytryptamine after induction of liver tryptophan pyrrolase by hydrocortisone: roles of tryptophan catabolism and kynurenine synthesis. *Br.J.Pharmacol.*, 74, (3) 695-700 available from: PM:7296169
- Young, S.N. & Sourkes, T.L. 1975. Tryptophan catabolism by tryptophan pyrrolase in rat liver. The effect of tryptophan loads and changes in tryptophan pyrrolase activity. *J.Biol Chem.*, 250, (13) 5009-5014 available from: PM:1150652
- Youngner, S.J., Landefeld, C.S., Coulton, C.J., Juknialis, B.W., & Leary, M. 1989. Brain death and organ retrieval: a cross-sectional survey of knowledge and concepts among health professionals. *Jama*, 261, (15) 2205-2210

Zaouali, M.A., Padrissa-Altes, S., Mosbah, I.B., Abdennebi, H.B., Boillot, O., Rimola, A., Saidane-Mosbahi, D., & Rosello-Catafau, J. 2010. Insulin like growth factor-1 increases fatty liver preservation in IGL-1 solution. *World journal of gastroenterology: WJG*, 16, (45) 5693