

Artículo de investigación

Analytical and experimental study of the deformation of roller cone bit parts

Аналитическое и экспериментальное исследование деформации деталей шарошечного долота
Estudio analítico y experimental de la deformación de piezas de brocas de cono de rodillo

Recibido: 20 de mayo del 2019. Aceptado: 23 de junio del 2019

Written by:
Pyalchenkov V.A.⁶
Kulyabin G.A.⁷
Dolgushin V.V.⁸
Pyalchenkov D.V.⁹

Abstract

Distribution of load between the cutting elements of the roller cutter drill bit depends on several factors, among them on the stiffness of the drilling-bit assembly. To deduce the dependencies of the stiffness of the drilling-bit assembly on the drill bit design and the point of application of the external load, the scheme of static interaction of the rolling cutter drill bit with the non-deformable bottom hole is considered. The calculation results allow to conclude, that the vertical stiffness of the drilling bit assembly has a maximum value at the contact with the bottom hole of the middle teeth rows of the roller cutters. For verification of the results of the analytical calculations the experimental measurements of the vertical movements of the rolling cutters of the roller cutter drill bit at the contact of those with bottom hole with the teeth of the different teeth rows have been made. The proposed methodology can be used to optimize the design of the roller cutter drill bits at the blueprint stage.

Keywords: drilling, bit, roller cone, support, roller cone cutting structure, load, deformation, rigidity.

Аннотация

Распределение нагрузки по элементам вооружения шарошечного долота зависит от ряда факторов, в том числе от жесткости шарошечного узла. Для получения зависимостей жесткости шарошечного узла от конструкции долота и точки приложения внешней нагрузки рассматривается схема статического взаимодействия шарошечного долота с недеформируемым забоем. Результаты расчетов позволяют сделать вывод о том, что вертикальная жесткость шарошечного узла имеет максимальное значение при контакте с забоем средних венцов шарошки. С целью проверки результатов аналитических расчетов проведены экспериментальные измерения вертикального перемещения шарошек долота при контакте их с забоем зубками различных венцов. Предлагаемая методика может использоваться для оптимизации конструкции шарошечных долот на стадии их проектирования.

Ключевые слова: бурение, долото, шарошка, опора, вооружение шарошки, нагрузка, деформация, жесткость.

⁶ Industrial University of Tyumen, 38 Volodarskogo St., Tyumen, 625000, Russia, pjalchenkovdv@tyuiu.ru

⁷ Industrial University of Tyumen, 38 Volodarskogo St., Tyumen, 625000, Russia

⁸ Industrial University of Tyumen, 38 Volodarskogo St., Tyumen, 625000, Russia

⁹ Industrial University of Tyumen, 38 Volodarskogo St., Tyumen, 625000, Russia

Resumen

La distribución de la carga entre los elementos de un armamento de broca de rodillo depende de varios factores, incluida la rigidez del nudo de rodillo. Para obtener las dependencias de la rigidez de una junta de rodillo en el diseño de la broca y el punto de aplicación de una carga externa, se considera un esquema de interacción estática de una broca de rodillo con una cara no deformable. Los resultados del cálculo nos permiten concluir que la rigidez vertical del nudo del rodillo tiene un valor máximo en contacto con la parte inferior de los bordes centrales del cono del rodillo. Para verificar los resultados de los cálculos analíticos, se realizaron mediciones experimentales del movimiento vertical de los conos de bits cuando estaban en contacto con los dientes de varias coronas. La técnica propuesta se puede utilizar para optimizar el diseño de las brocas de rodillo en la etapa de diseño.

Palabras clave: taladrado, cincel, cortador de rodillos, soporte, armamento cortador de rodillos, carga, deformación, rigidez.

Introduction

Reliability and durability of drill bits depend on the magnitude of the forces acting on the cone teeth directly destroying the rock. A significant number of both analytical and experimental works are devoted to the study of the patterns of interaction between the armament of roller bits and the bottom hole. The model of interaction between the armament of the bit and the rock was proposed in (Spivak A.I., 1994). A bit tooth affects the rock, making a complex movement, depending on the parameters of rotation of the cone and bit, the cone slip at the bottom. Experimental studies of the interaction of individual elements of the armament of the bit with the rock are made according to the drilling scheme with one tooth. In (Geoffroy H. 1997, Rao K.U.M., 2002) the results of an experimental study of the interaction of the bit with the rock are given. In (Elsayed M.A., 2001), the axial force acting on the bit from the side of the rock being destroyed is determined. In (Spivak A.I., 1994, Eygeles R.M., 1993), analytical dependencies are proposed for determining the speeds of impact and movement of elements of the roller-cone crown gear in contact with the bottom, as well as non-linear dependencies between the angles of rotation of the crown around its axis and around the axis of the bit when working on the deformed bottom. Using wear resistance in this model as an optimization criterion, the author (Bilanenko N.A., 1994), by varying the geometric parameters, determines their optimal ratio. In (Eygeles R.M., 1993), a model is considered, which is a set of interrelated modules for calculating kinematics and bit dynamics, drilling string oscillations, as well as the formation and deepening of the bottom during drilling. For a given combination of parameters of the bit design and drill string and drilling conditions, the model allows determining for any drilling time point the distribution of

forces and movements of any point of the drilling tool, starting from the upper end of the drill string and ending at the tips of the bit cone teeth. Various mathematical models of roller bits for the analytical determination of the forces acting on the bearings of the roller cones are proposed in (Eygeles R.M., 1993, Postash S.A., 1959). In (Komm A.L., 1976), a technique and a set of devices and measuring instruments for experimental determination of the loads exerted on each cone during work at the bottom was proposed. A number of experimental studies performed on various devices, for example (Vladimir A. Pyalchenkov, 2017, Pyalchenkov V.A. 2017), are devoted to solving this problem.

The process of interaction of a roller bit with the bottom is very complex, depending on a large number of factors. Each roller cone, rolling over the bottom, makes a complex movement, consisting of rotation of the roller cone around the axle of the bearing pin, rotation around the vertical axis of the bit, and vertical translational motion as the rock breaks down. Since the cones are not kinematically interconnected, the number of teeth that are simultaneously in contact with the bottom is a random value, and accordingly, the number of links of the bit with the bottom will also be a variable value. The maximum axial force acts on the tooth at the moment of its transition through the vertical position. And since the teeth of the crowns of the roller cone are displaced relative to each other along the generators, it can be assumed that most often each roller cone will come into contact with the bottom with only one tooth in an upright position. This assumption is especially true when drilling hard and extremely hard rocks. Based on this assumption, we consider the bit in a static state, each roller cone of which rests on a smooth, non-deformable bottom with one tooth.

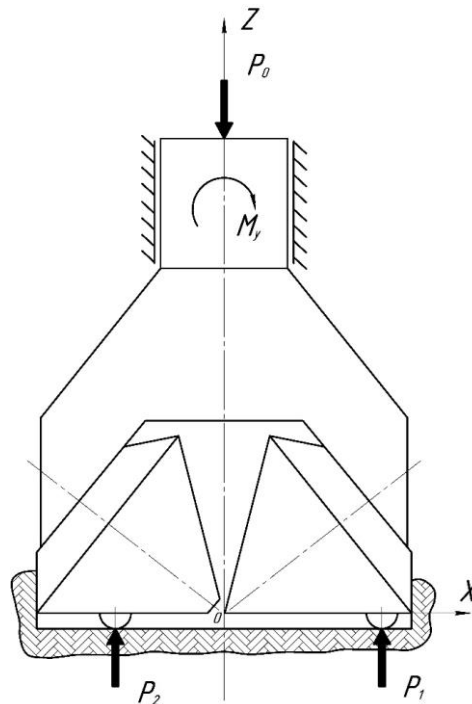

Fig.1. Forces acting on the bit.

METHODS

The body of the bit and the bottom will be considered non-deformable and, moreover, we assume that the bit can only move parallel to the Z-axis without distortions under the load. Under these assumptions, the movement Δ_1 and Δ_2 of the points of application of the forces P_1 and P_2 relative to the bit body will be the same. This system is once statically indeterminable, and to find the unknown values of P_1 and P_2 , we can use one static equation (1) and the deformation condition of the system (2):

$$P_2 = P_0 \quad (2)$$

$$\sum Z_i = 0; P_1 + P_2 = P_0 \quad (1)$$

$$\Delta_1 = \Delta_2$$

To solve this system, it is necessary to establish a relationship between the magnitude of the load acting on the roller cone and the vertical movement of this tooth. For tricone bits, the sequence of arguments remains the same. These dependencies can be obtained analytically or experimentally.

The design of the support assemblies of all the cones of the bit is the same and therefore the vertical rigidity of each cone will vary depending on which radius of the bit is the tooth in contact with the bottom at the moment. Let us consider one section of the bit. A force P parallel to the axis of the bit at a distance R from the axis of the bit (Fig.2) acts on the roller cone of the section. It is necessary to determine the vertical movement of the point of application of force.

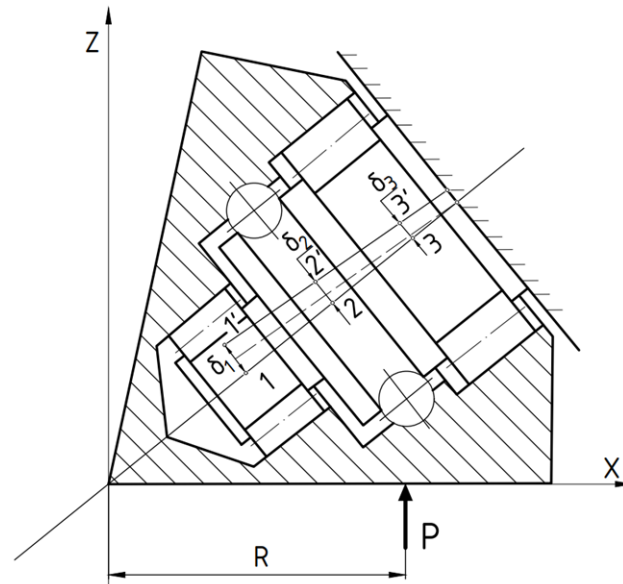

Fig.2. The design scheme of a roller-cone assembly.

The axial moment of resistance of the cross section of the cone body is many times the axial moment of resistance of the cross-section of the bearing pin. Therefore, it can be assumed that the deformation of the roller cone body will be insignificant compared to the deformation of the bearing pin and contact deformations in bearings and it can be neglected. Thus, the movement of the roller cone will occur due to the deformation of the bearing pin and the elastic contact deformations in the bearings. In order to determine these deformations, it is necessary to know the values of the reactions in the bearings.

The solution to this problem is given in (Pyalchenkov V.A., 2017). Using these results, we determine the value of the vertical movement of point A of the roller cone (Fig. 3), in which the force R is applied. Let the coordinate system ZOX be stationary, and the system $Z_2O_2X_2$ be movable rigidly connected with the roller cone whose origin is in the centre of the lower ball. When the force P is applied, the roller cone will move and the coordinate system $Z_2O_2X_2$ will take a new position $Z_3O_3X_3$.

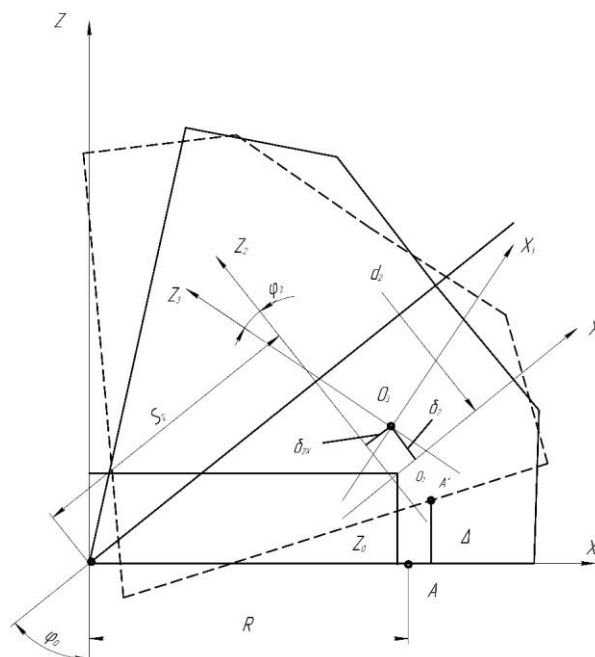

Fig.3. Scheme for the calculation of the vertical movements of the point of application of external force.

We consider that the radial movement of the point $O_2 - \delta_2$ is known to us (Pyalchenkov V.A., 2017). The axial movement of the point $O_2 - \delta_{2x}$ occurs under the action of the axial force in the ball bearing F_{2S} . To determine the axial movement, we use the method given in (Kovalev M.N., 1971). Since we have assumed that the radial clearances in the bearings are zero, the initial angle of contact of the balls with the raceways will also be zero. For this case, the axial movement of the bearing δ_{2x} , the actual angle of contact of the balls with the raceways α and the effective axial force F_{2S} are related by dependencies:

$$\delta_{2x} = (\gamma * d_2) \tan \alpha; \quad (3)$$

$$F_{2S} = C * \left(\frac{1}{\cos \alpha} - 1 \right)^{\frac{3}{2}} * \sin \alpha; \quad (4)$$

Where:

C^* – bearing strength characteristic

γ – coefficient depending on the size of the bearing.

Since equation (4) cannot be solved explicitly, we will solve it approximately by introducing the change of variable $\alpha = x$ and using the expansion in the series of trigonometric functions $\frac{1}{\cos x}$ and $\sin x$, taking into account three members in the first one, and in the second one - two members. Then equation (4) is converted to:

$$\frac{X^4}{2^{\frac{3}{2}}} \cdot \left(1 + \frac{5}{12} \cdot X^2 \right) \left(1 - \frac{1}{6} \cdot X^2 \right) = \frac{F_S}{C^*}; \quad (5)$$

/4.2.49/

The solution of this equation by the method of successive approximations has the form:

$$X_k = \frac{X_0}{\sqrt[4]{\left(1 + \frac{5}{12} \cdot X_{k-1}^2 \right) \cdot \left(1 - \frac{1}{6} \cdot X_{k-1}^2 \right)}}; \quad (6)$$

Where: $k = 1, 2, \dots$

The verification showed that even at $k = 1$, the value α_1 practically does not differ from α . From the found value of the contact angle α we determine from expression (3) the desired movement of the ball δ_{2x} . The angle of rotation φ_2 of the coordinate system $Z_3O_3X_3$ can be determined from the consideration of the radial

deformations in the lock ball and one of the radial bearings (Fig. 2).

$$\varphi_2 = \arctg \left(\frac{\delta_3 - \delta_2}{a_6} \right); \quad (7)$$

Here, a_6 is the distance between these bearings. When moving the cone, point A will take a new position - A^1 . To determine the value of the vertical movement of point A, it is necessary to find the Z coordinate of point A^1 in the ZOX coordinate system. The coordinates of point A^1 in the coordinate system $Z_3O_3X_3$ can be determined by:

$$X_3 = R \cdot \sin \varphi_0 - S_2; \quad (8)$$

$$Z_3 = d^2 / 2 - R \cdot \cos \varphi_0;$$

To determine the coordinates of point A^1 in the system ZOX, we write the formulas for the transition from the coordinate system $Z_3O_3X_3$ to the system ZOX. The coordinates of point A^1 in the $Z_3O_3X_3$ system are determined by:

$$X_2 = X_3 \cdot \cos \varphi_2 - Z_3 \sin \varphi_2 + \delta_{23}; \quad (9)$$

$$Z_2 = X_3 \cdot \sin \varphi_2 + Z_3 \cdot \cos \varphi_2 + \delta_2;$$

Then the desired value of Z, equal to the vertical movement of point A is determined by:

$$\Delta = Z = Z_0 + Z_2 \cdot \sin \varphi_0 + X_2 \cdot \cos \varphi_0; \quad (10)$$

/4.2.53/
 Where,

$$Z_0 = S_2 \cdot \cos \varphi_0 - \frac{d_2}{2} \cdot \sin \varphi_0; \quad (11)$$

To obtain the dependencies of the vertical movement of point A on the force P and the radius of its application R, which we are interested in, is not possible in an explicit form. Therefore, these dependencies were obtained for

the bit support Sh215,9K-PV as a table of values for various values of P and R.

RESULTS

According to the results of the calculations, graphical dependencies of the vertical movement of the roller cone on the value of the force acting

on the roller cone and the radius of its application, shown in Fig.4, were constructed.

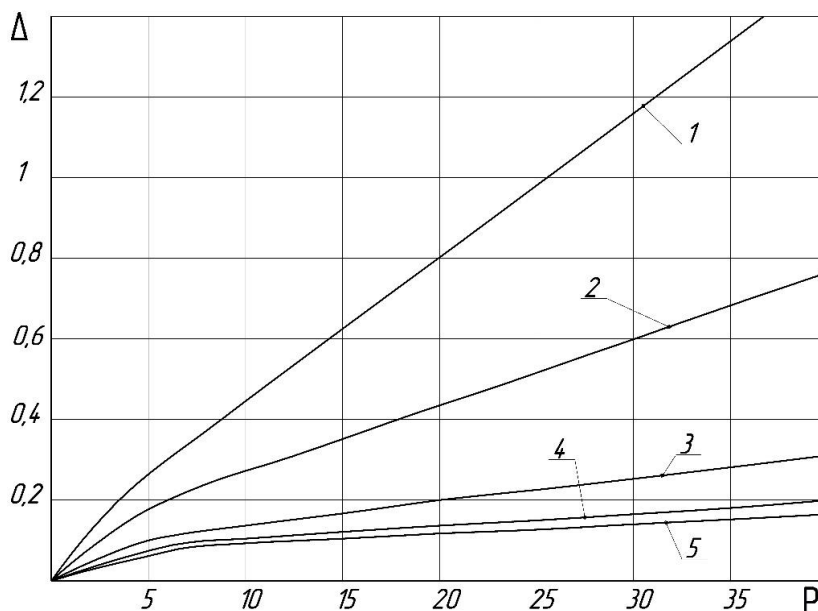

Fig.4. The calculated dependencies of the vertical movement of the roller cone Δ (mm) on the value of P (kN) and the radius R (mm) of the external force.
1- $R=30$ mm, 2- $R=50$ mm, 3- $R=70$ mm, 4- $R=90$ mm, 5- $R=100$ mm.

The graphs show that the change in the vertical movement of the roller cone from the acting force has a linear relationship for loads P of 10 kN. The dependency of the vertical movement of the cone on the radius of application of force is more complex. As the radius increases to $R = 90$ mm, the deformation value decreases, i.e. the axial stiffness of the system increases.

With a further increase in the radius of application of the load, the calculated axial rigidity of the system again slightly decreases. The change in the axial stiffness of the roller cone assembly when the radius of application of the external load on the roller cone changes, is obviously determined by the change in the stress state of the parts of the roller cone support. When

the radius of application of the external load changes, the load is redistributed among the bearings (Pyalchenkov V.A., 2017).

In order to verify the analytical calculations of the deformation of the parts of the bit, experimental measurements were made of the vertical movement of the cones of the Sh215,9K-PV bit when the teeth of various crowns were in contact with the bottom. The measurements were made on a test bench, where with the help of a special device and a set of hour-type indicators, the "axial load - vertical crown movement" diagram was taken. Fig. 5 shows a scheme for measuring the vertical movements of the roller cones.

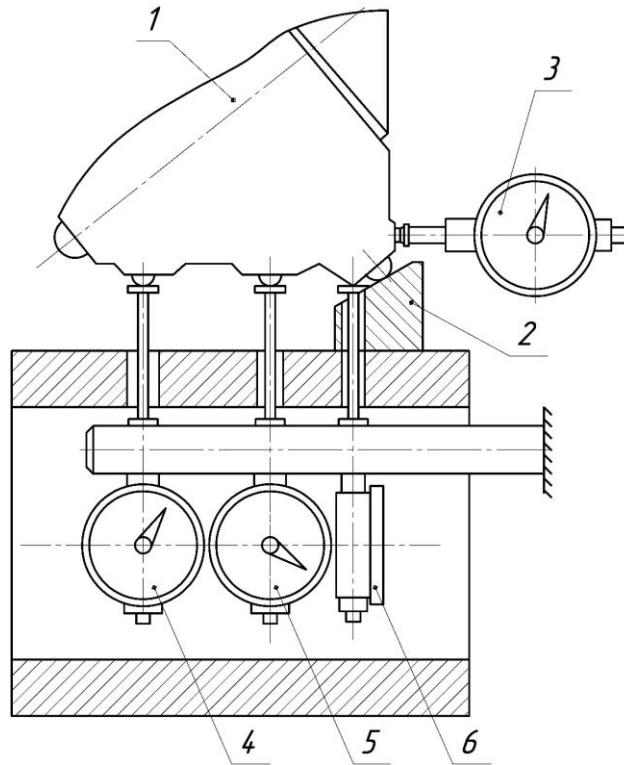

Fig. 5. Scheme for measuring the vertical movements of the cone.
(1 – bit; 2 – bottom; 3,4,5,6 - indicators)

Bit1, installed in the spindle of the stand and additionally attached to the gearbox housing, rests on the bottom 2 with teeth of only one crown of one roller cone. The axial load, varying in steps from 0 to 40 kN, was created on the bit using the stand hydraulic system. At each value of the force on the bit, indicators 3,4,5,6 were fixedly mounted on racks, movements of various points of the roller cone were measured, and as a result of the recalculation, the vertical movement of the point of interest of the roller cone was determined. The measurement of the deformation of each crown was repeated many times, with each measurement being made after turning the roller cone at some arbitrary angle. The value of the vertical movement of the crown from the load acting on it was determined as an average value from the results of all measurements. When an axial force is applied to

the bit, vertical movement of the roller cone occurs not only as a result of the deformation of the bit elements but also as a result of the deformation of the gearbox housing in which the bit was fixed. In order to eliminate the effect of these deformations on the measurement results, the diagram "axial load - vertical movement of the gearbox housing" was simultaneously taken. The value of the actual vertical movement of the roller cone at each load value was determined as the difference between the measured vertical movement of the crown and the vertical movement of the gearbox housing. Figure 6 shows the experimental dependencies "axial load on the crown - vertical movement of the crown" for the crowns of each roller cone of the Sh215,9K-PV bit located on different bit radii.

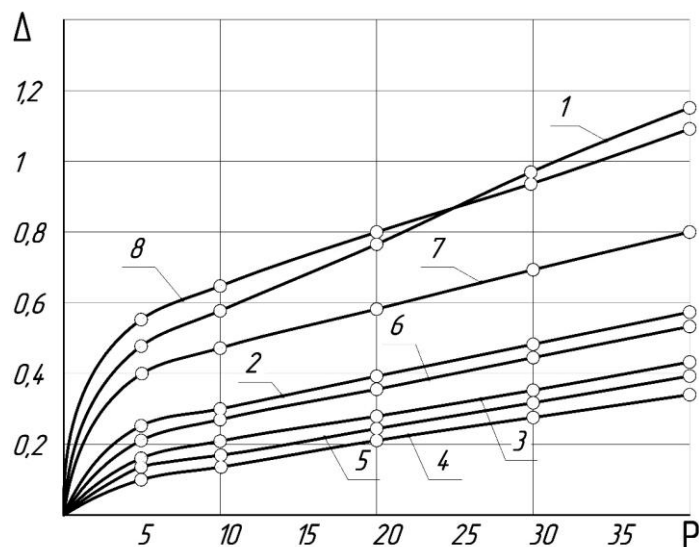

Fig. 6. Experimental dependences of the vertical movement Δ (mm) of the crowns of the Sh215,9K-PV bit cones on the load P (kN).

1- $R=106$ mm, 2- $R=94$ mm, 3- $R=84$ mm, 4- $R=71$ mm, 5- $R=59$ mm, 6- $R=45$ mm, 7- $R=33$ mm, 8- $R=22$ mm.

DISCUSSION

The dependence of the vertical crown movement on the force acting on it does not obey the linear law. In the area of small values of effort, displacements grow much more intensively than in the area of large loads. From this we can conclude that the movement of the crown under any loads occurs mainly due to the selection of gaps and elastic contact movements in the joints of the bit parts (in the support), obeying such laws (Levina Z.M., 1971). The nonlinearity of the movement change is associated with an increase in the actual contact area with increasing load. Especially noticeable is the nonlinearity of the movement of the peripheral and apical crowns of all the cones. For the middle crowns of the cones, the length of the nonlinear part of the graph is shorter than for the other crowns. The continuous increase in the movement of the crowns with increasing load can be explained by the presence of not only contact deformations in the joints and movements due to the selection of gaps but also the elastic deformation of the parts of the bit and first of all the bearing pins. The smallest vertical movements with identical active loads are observed for middle crowns. If we

compare the experimental dependences with the results of calculations, then in the presence of significant quantitative differences in the results obtained, the qualitative regularity still remains. Figure 7 shows the dependency of the vertical movement of the roller cone on the radius of application of the force, obtained as a result of calculations and experimentally with an axial load of 20 kN on the roller cone. Both dependencies have a minimum, but the position of this minimum is different.

CONCLUSIONS

As a result of experimental measurements, it was found that the smallest vertical movement (highest vertical stiffness) of the roller cone is observed when the load radius is 70 mm. When the radius of application of the load is less than 60 mm, the difference between the calculated values of the vertical movements of the cones and the actual movements does not exceed 0.15 mm. The calculated values of movements with a radius of less than 70 mm are greater than the actual ones and with a radius of greater than 70 mm - less than the actual ones.

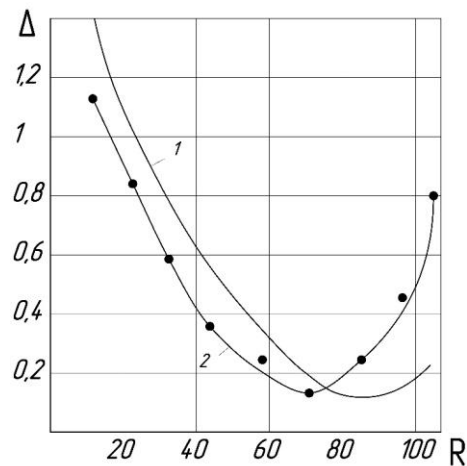

Fig. 7. Calculated and experimental dependencies of the movement of the cone Δ (mm) on the radius of application R (mm) ($P = 20$ kN).

However, with a radius of application of a load of 100 mm, the difference between the calculated and actual movements reaches 0.4 mm. Therefore, actual movements are almost three times the calculated ones. Such significant differences in the results are probably due to the assumptions that were introduced when calculating the deformation and effort in the parts of the roller cone support. So, in the calculations, it was assumed that the gaps in the bearings are zero and the load is exerted on all three bearings. In addition, when determining the contact deformations and movements in roller bearings, it was assumed that the load is distributed evenly along the generator of the roller and the resultant is applied in the middle of the contact line. In fact, due to the selection of gaps, and different values of the total deformations in the end and in the peripheral roller bearings, there is a distortion of the roller cone on the pin. This leads to the redistribution of specific loads along the lines of contact of the rollers with the bearing pin and roller cone, which, in our opinion, significantly reduces the contact stiffness in roller bearings. With a further increase in the radius of application of the load, the calculated axial rigidity of the system slightly decreases again. The change in the axial stiffness of the roller-cone assembly when the radius of application of the external load on the roller cone changes, is obviously determined by the change in the stress state of the parts of the roller cone support. When changing the radius of application of the external load, the load is redistributed among the bearings. The proposed method of analytical and experimental study of the deformation of parts of the bit can be used for

analytical evaluation of crown loads and optimization of the design of armament and supports of the roller cone bit.

REFERENCES

- Bilanenko N.A. (1994). The establishment of optimal kinetic characteristics of roller bits in order to improve the efficiency of well drilling: dissertation for the degree Candidate of Engineering. Tashkent. Uzbekistan.
- Elsayed M. A., Washington L. E. (2001). Drillstring Stability Based on Variable Material Specific Force and Using a Sharp Three-Insert Polycrystalline Diamond Compact (PDC) Coring Bit. *J. Of Energy Resources Technology*. Vol. 123. pp. 138-143.
- Eygeles R. M., Levina A. B., Lubyany D. A. (1993). Modeling of kinematics and the dynamics of roller-cone bits. *Construction of oil and gas wells on land and at sea*. Vol. 1-2. pp. 41-43.
- Geoffroy H., Nguyen Miah D., Putot C. (1997). Study on Interaction between Rocks and Worn PDC's Cones. *Int. J. of Rock Mechanics and Mining Sciences*. Vol. 34. Num. 314. pp. 611-620.
- Komm A.L., Perlov G.F., Mokshin A.S. (1976). Studying the loading of roller bit sections. *Proceedings of VNIIBT*. Issue 36. pp. 27-36.
- Kovalev M.N., Narodetsky M.Z. (1980). Calculation of high-precision rolling bearings. *Mashinostroyeniye*. Moscow.

Levina Z.M., Reshetov D.N. (1971). Contact stiffness of machines. Mashinostroyeniye. Moscow.

Pyalchenkov V.A., Dolgushin V.V., Kulyabin G.A. (2017). The model for studies of load for the roller bit support bearings. ARPN Journal of Engineering and Applied Sciences. Vol. 12. Num. 19. pp. 5548-5553.

Pyalchenkov V.A., Dolgushin V.V., Kulyabin G.A., Nikitina L.I. (2018). Analysis of the Stressed State of Bearing Elements of the Support of the Rolling Cone Bit. Research Journal of Pharmaceutical, Biological and Chemical Sciences. Vol. 9(4). pp.826-836.

ostash S.A. (1959). On the calculation of supports of tricone bits. News of higher educational institutions. Oil and gas. Vol. 8. pp. 91 – 98.

Rao K. U. M., Bhatnagar A., Misra B. (2002). Laboratory investigations on rotary diamond drilling. Geotechnical and Geological Engineering. Vol. 20. pp. 1-16.

Spivak A.I., Popov A.N. (1994). The destruction of rocks in the drilling of wells: a textbook for high schools. Nedra. Moscow.

Vladimir A. Pyalchenkov (2017). Methodology of experimental measurement of loads, acting on rock cutting elements of drilling bit. International Journal of Applied Engineering Research. Vol. 12, Num. 22. pp. 11901-11906.