



POLITECNICO DI TORINO  
Repository ISTITUZIONALE

AIM (Artery in microgravity): Design and development of an ice cubes mission

*Original*

AIM (Artery in microgravity): Design and development of an ice cubes mission / Drayson, O.; Bernardini, N.; Abderrahaman, A. B.; Cerquetani, L.; Cipolletta, A.; Ferrer, B. D.; Falcone, F.; Gabetti, S.; Genoni, M.; Torta, E.; Vagnone, F.; Audas, C.; Compin, M.; Favier, J. -J.; Lizy-Destrez, S.; Morbiducci, U.. - (2019). ((Intervento presentato al convegno 70th International Astronautical Congress, IAC 2019 tenutosi a Washington DC (USA) nel 2019.

*Availability:*

This version is available at: 11583/2842038 since: 2020-07-30T16:38:31Z

*Publisher:*

International Astronautical Federation, IAF

*Published*

DOI:

*Terms of use:*

openAccess

This article is made available under terms and conditions as specified in the corresponding bibliographic description in the repository

*Publisher copyright*

(Article begins on next page)

## AIM (Artery in Microgravity): Design and Development of an ICE Cubes Mission

**Olivia Drayson<sup>a</sup>, Nicolò Bernardini<sup>a</sup>, Amina Bakkali Abderrahaman<sup>a</sup>, Luca Cerquetani<sup>a</sup>, Alessandro Cipolletta<sup>a</sup>, Blanca Dalfó Ferrer<sup>a</sup>, Federico Falcone<sup>a</sup>, Stefano Gabetti<sup>b</sup>, Michele Genoni<sup>a</sup>, Elena Torta<sup>b</sup>, Federica Vagnone<sup>a</sup>, Chloé Audas<sup>c</sup>, Matthieu Compin<sup>a</sup>, Jean-Jacques Favier<sup>a</sup>, Stéphanie Lizy-Destrez<sup>a</sup>, Umberto Morbiducci<sup>b</sup>**

<sup>a</sup> ISAE-Supaero University of Toulouse, France

<sup>b</sup> Politecnico di Torino, Italy

<sup>c</sup> Space Applications Services, NV/SA

### Abstract

The Artery In Microgravity (AIM) project is the first experiment to be selected for the “Orbit Your Thesis!” programme of ESA Academy. It is a 2U experiment cube designed for the ICE Cubes facility on board of the International Space Station. The experiment is expected to be launched on SpaceX-20 in early 2020. The project is being developed by an international group of students from ISAE-SUPAERO and Politecnico di Torino, under the supervision of the ISAE-SUPAERO and Politecnico di Torino staff.

The experiment is a test-bench for investigating haemodynamics in microgravity focusing on coronary heart disease, the most common form of cardiovascular disease and the cause of approximately 9 million deaths every year. Coronary heart disease is caused by stenosis of the coronary artery due to the build-up of plaque. While the development of atherosclerosis is not fully understood, the primary event seems to be subtle and repeated injury to the artery walls through various mechanisms including physical stresses from flow disturbances as well as from systemic and biological risk factors. In the presence of severe stenosis, patients are treated with the implantation of one or more coronary stents, which are tubular scaffolds devoted to restore and maintain myocardial perfusion. The coronary stenting procedure is largely applied (e.g., 1.8 million stents per year implanted in USA)

In view of the impact that coronary artery disease has on humans, as well as of the increasing number of people that will be involved in space flights in the future, the way astronauts in space coronary hemodynamics is affected by the absence of gravity in the presence of stenosis or of stenting needs to be investigated in depth. In addition, as most stents are metallic objects, the radiation exposure in space might interact with their surface, altering blood flow, inducing particles release and ultimately leading to stent failure.

Therefore, the aim of AIM is to start studying the vascular haemodynamics in a stented and a stenosed coronary artery on Earth and in microgravity and the stent-radiation coupling. This will allow to learn about the effect gravity plays on coronary artery haemodynamics, the effects of microgravity and radiation on the performance of implantable devices and ultimately the risks of myocardial infarction to astronauts on long-distance spaceflight.

The experimental setup consists of a closed hydraulic loop containing two models of a coronary artery in series. An electric pump and reservoir will control the flow of a blood-mimicking fluid through the system. One model of the coronary artery will contain a coronary stent. The pressure of the fluid will be studied along its path using a series of pressure sensors and a camera will visualise the flow. The same experiments will be repeated on the ground with the same conditions as the in-flight model for comparison.

The paper will outline in detail the design and development of the AIM experiment cube and the results of testing. The full data and results will be available after the completion of the mission which is expected to be between March and June 2020.

**Keywords:** ISS, coronary artery, stent, microgravity, haemodynamics

### 1. Introduction

As interest in Mars exploration and advancing human space exploration increases, so does the need for a better understanding of the health risks associated with deep-space exploration. Long-term exposure to both microgravity and cosmic radiation pose serious health problems and remain challenges to be overcome.

The cardiovascular system is negatively impacted by both of these factors. Given that the human

cardiovascular system evolved in an upright posture in a 1-g environment, leaving Earth's environment, and consequently being exposed to microgravity, causes unique stresses. Long-term spaceflight might lead to the triggering of disease or speed up the development of pre-existing pathological conditions.

For this reason, the AIM (Artery in Microgravity) project was devised, aiming to investigate how long-term exposure to the space environment impacts the cardiovascular system, the development of

cardiovascular disease (CVD) and the performance of a common treatment for CVD - the coronary stent.

The AIM experiment is a 2U experiment cube designed for the ICE Cubes facility onboard the ISS. The project is a multidisciplinary and international project which is the product of a collaboration between students from ISAE-SUPAERO in Toulouse, France and Politecnico di Torino in Turin, Italy. The project was selected for the first ever Orbit Your Thesis! programme and thanks to the ICE Cubes service of Space Applications Services and to ESA Academy, the experiment cube will fly on board the ISS in 2020.

### 1.1 ICE Cubes

The International Commercial Experiment Cubes or ICE Cubes service is a commercial service created by Space Applications Services in partnership with ESA that allows experiments to be launched and performed on the ISS. The aim of this service is to simplify the process of launching an experiment on board the ISS by reducing the cost to the researchers and by reducing the size and complexity of the housing system. The service includes: the accommodation of the experiment on the ICE Cubes Facility (ICF) in the Columbus module racks for 4 months, an out-of-the-box software suite, the capability to either downlink data in real time or to obtain it from a physical storage medium, and disposal/return after operation. The service also includes guidance with experiment cube design, interface testing, experiment certification and operational support.

### 1.2 Orbit Your Thesis!

The ‘Orbit Your Thesis!’ programme is the latest student opportunity of ESA Academy. This programme sponsors and supports a group of Master and PhD students to develop an experiment that will be launched to the International Space Station in the ICE Cubes facility. The other programmes of ESA Education include ‘Fly Your Thesis!’, ‘Spin Your Thesis!’, ‘Spin Your Thesis! Human Edition’, ‘Drop Your Thesis!’, and ‘Fly Your Satellite’ in which students develop an experiment for a Novespace parabolic flight, the Large Diameter Centrifuge in ESTEC, the Short Arm Human Centrifuge in Cologne, the ZARM Drop Tower in Bremen and launch into space respectively.

### 1.3 AIM Project

The AIM experiment will investigate coronary heart disease, the most common form of cardiovascular disease and the cause of approximately 9 million deaths every year. In view of the very long duration missions to come, such diseases may also affect healthy astronauts in space. The AIM cube is a test-bench for

investigating haemodynamics in microgravity and will study the effects of microgravity on blood flow in the coronary artery with and without an implanted coronary stent and the impact of augmented radiation levels on metallic ion release from coronary stents.

## 2. Organisation of the AIM Project

The AIM is an international and multi-disciplinary student project. The project is a collaboration between ISAE-SUPAERO in Toulouse, France and Politecnico di Torino, Italy. The team is composed of 11 Master Students from ISAE-SUPAERO, specialising in aerospace engineering and one Master and one PhD student from Politecnico di Torino, both specialising in biomedical engineering.

After conception of a preliminary experiment design, the priority of the project leaders was to build a team for the project. Originally the project team consisted of only master’s students from ISAE-SUPAERO specialising in different majors of Aerospace Engineering. The Mechanical team was chosen to consist of students specialising in Aerospace Structures. The Electronics team was chosen to consist of students specialising in Control and Space Systems. The Scientific team was chosen to consist of students specialising in Space Systems. In order to provide medical expertise to the team, two Biomedical Engineering students were recruited to the scientific team from Politecnico di Torino.

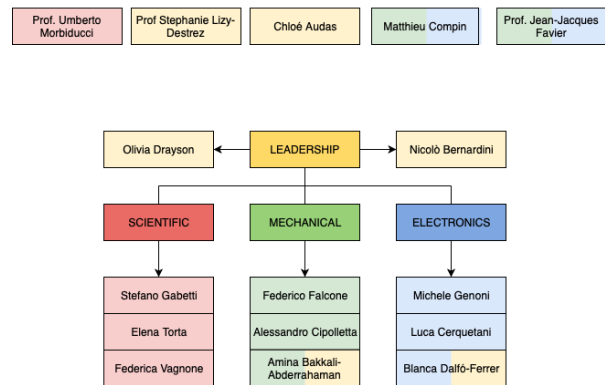

Fig. 1. Team AIM (Project Management - Yellow, Scientific Team -Red, Mechanical Team - Green, Electronics Team - Blue)

Since the project lasted longer than the Master’s degrees of the technical branch of the team, two incoming students were recruited to take over leadership. They were chosen to be students specialising in Space Systems and were trained in order to lead one of the two branches of the technical branch.

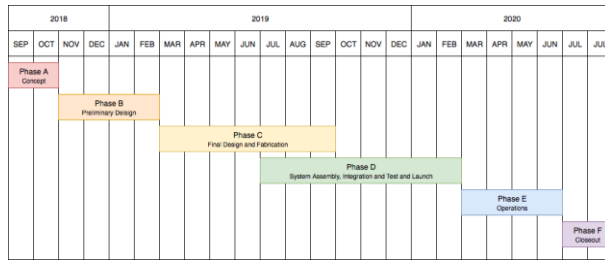

Fig. 2. Gantt diagram of the main phases for the AIM project

### 3. Scientific Context

Cardiovascular disease (CVD) is the leading cause of death in the world: in 2012 it was estimated that the annual number of deaths from CVD would rise from 17.5 million to 22.2 million by 2030 [1]. The risk is significantly increased after exposure to high doses of radiation (radiation-induced CVD or RICVD) [2]. Space exploration also increases the risk of CVD through other factors independent from radiation, such as confinement and reduced gravitational loading. Therefore, both microgravity and radiation in the space environment are potential triggers for deterioration of the cardiovascular system during manned space exploration [2].

RICVD comprises various types of pathologies including valvular heart disease, cardiomyopathy, conduction abnormalities, pericarditis and coronary artery disease [2]. In particular, neutrons cause the degeneration of smooth muscle cells and plaque formation in the aorta and coronary arteries, while HZE particles determine expression of genes related to cardiovascular function and pathology, resulting in degenerative tissue changes and accelerating the onset of atherosclerosis, which is considered a common feature for the onset of many complications, such as ischaemic disease or coronary artery disease [2].

Atherosclerotic lesions (atheromata) are asymmetric focal thickening of the innermost layer of the artery (the intima) [3]. Different types of risk factors (systemic, biological and haemodynamic factors) encourage the formation of the atheromatic plaque: for example, hypertension has a remarkable impact on local haemodynamics, since it increases systemic impedance. The resulting friction forces exerted by blood stream on the vascular wall leads to a change for what concerns genic expression, triggering inflammatory processes. If this process is not monitored, it could result in myocardial infarction, which occurs when blood cannot flow through the coronary artery.

The localisation of atherosclerosis in the coronary arteries may be governed by local haemodynamic features. Haemodynamic shear stress has been shown to be an important factor in the development of atherosclerosis at several important sites

of the arterial system. The wall shear stress distribution can be used to statistically evaluate the role of haemodynamics in the development of atherosclerotic plaque in coronary arteries: in fact, it has been estimated that atherosclerotic sites strongly implicate low and oscillating shear stress as the localising factor for plaque development in humans [4]. Moreover, other aggravating flow events are the presence of vortical flows, stagnation point flows, high shear stress regions (which leads to friction forces on the endothelial lining, with the consequent risk of lacerating the vessel) and hypertension flows, which are flows affected by a higher resistance with respect to the physiological one.

The occlusion of a coronary artery can be treated in different ways, among which the most relevant is the implantation of a coronary stent. A coronary stent is a small tubular mesh usually made of stainless steel, cobalt-chromium alloys or Nitinol. This device is inserted into stenotic arteries at the site of a narrowing to keep the arteries open. It acts as an internal scaffolding or as a support, allowing the blood to flow, thus restoring the original haemodynamics. Nevertheless, it is important to evaluate haemodynamics also in a stented coronary artery, since the biological processes leading to stent failure (e.g. in-stent restenosis) have been found to be partially flow-dependent. The mechanisms and the causes of in-stent restenosis in coronary arteries are not fully understood. One of the most relevant phenomena which seems to be associated with the formation of neointimal hyperplasia is altered haemodynamics in the stented wall region which leads to persistent low WSS [5]. There is the need to take into account both macroscopic and local quantities associated with blood flow, together with wall deformations and movements induced by fluid flow, in order to completely analyse these types of pathologies.

Moreover, in-stent restenosis might also be triggered by the degradation of stent struts in time. Stents manufacturing includes several surface treatments which guarantee device haemocompatibility. Radiation exposure might damage the surface coating and leave the internal structure exposed to blood flow, perturbing the haemodynamics and leading to possible thrombosis and metallosis. To comprehensively evaluate the effectiveness and durability of these treatments also the stent-radiation coupling mechanism has to be investigated.

#### 3.1 Space Benefits

The experiment will provide robust data for the evaluation of haemodynamics in space. As of yet, such an experiment has never been performed. The benefit will be mainly for future space travels, where not only highly-trained astronauts, but also civilians might be

involved. This study will give data which could help in better identifying possible hazardous situations.

There will also be the possibility for people with an endovascular device implanted to be on board and for this reason the interaction between radiation and the structure of these devices will have to be known in advance.

### 3.1 Earth Benefits

The experiment will give insights on the effects of gravity orientation on mechanical behaviour of vessels and on haemodynamics. This will be of help in understanding the development of pathologies and will provide consistent data to guide the design of better performing implantable devices.

In addition, since inflammatory response can be a cause of post-implantation re-stenosis, the evaluation of the release of metallic ions induced by radiation is of primary importance to assess the performance of stents in high radiation environments.

Space constitutes a natural environment where enhanced radiation exposure occurs. Radiation exposure has a cumulative effect, which is only visible after years. People doing some particular jobs, like mine workers, radiology technicians, flight attendants, aircraft pilots, are exposed on a daily basis to doses of radiation, which are however significantly higher with respect to the average. These people might have undergone endovascular surgery and might have a stent installed. Deterioration of the metallic alloy due to radiation has a double effect: possible chemical alteration of blood leading to metallosis, thrombosis and deterioration of the mechanical properties of the implanted device. While effects of radiation exposure on these implants could only be visible after several years, performing a test in an environment where radiation exposure is enhanced could be useful to gather significant data in a shorter time, in order to extrapolate data and evaluate a long-time behaviour of these stents.

## 4. Design of the AIM Experiment

The test bench, designed driven by modularity, will be made up of several parts. A pumping system will be used. The pump will be connected to the two coronary artery flow phantoms [6], one resembling a stenotic condition, the other a stented one.

The models, made of silicone so as to model the passive behaviour of vessels [6],[7], will be arranged in series, and the pump will provide the required flow rate. Tubing and flow straighteners will be included, together with a Windkessel [6] physical model mimicking the systemic impedance. The fluid will circulate through both models.

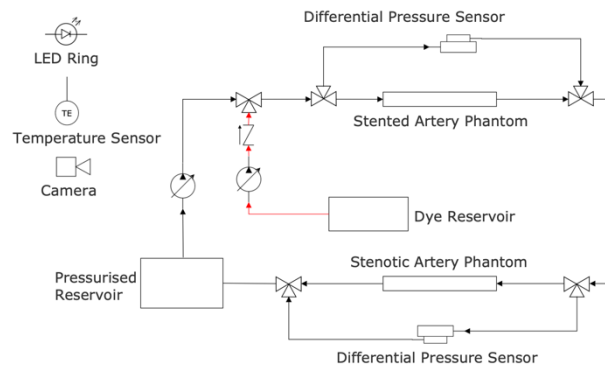

Fig. 3. Schematic of the hydraulic loop

Concerning the measurements, pressure will be measured at four different locations along the circuit, i.e. at the inlets and outlets of the two models. Wall motion and flow visualisation will be detected using a camera. Flow visualisation will be based upon the use of a passive tracer, which will be a suitable dye [6],[8].

Data will be recorded and stored by the motherboard to which the sensors will be connected. Pressure data from the sensors will be downloaded in real-time, as they will also serve as a telemetry. In addition, they don't have a consistent impact on the downlink budget.

Images recorded by the camera will be temporarily stored in a mass storage device connected to the board due to their size. After each experiment, data packets will be sent to Earth and will be post processed to analyse flow distribution and wall deformations in time.

Pressure time series will be analysed in time and frequency domains to give a complete description of macroscopic haemodynamics. In particular, as periodic signals can be represented by their Fourier series, these will be extracted for pressure and flow rate. The impedance of the two models will then be evaluated as [9]:

$$Z(\omega) = \frac{\Delta p(\omega)}{\dot{Q}(\omega)} \quad (1)$$

Image processing and segmentation algorithms will be applied to the acquired sequences. In order to track the flow pattern followed by the injected dye, Hue, Saturation, Value (HSV) values will be extracted from the Red, Green, Blue (RGB) ones to allow for image segmentation and subsequent flow visualisation of the dye [7]. Captured videos will be synchronised with the data acquired through pressure and flow sensors, in order to correlate flow distribution with the macroscopic quantities.

Space agencies are currently pursuing Mars exploration, including placing satellites in its orbit or undertaking landing missions using robots. Plans will require an extended presence of humans in space.

Health risks for the crew are a major hindrance to safe manned deep-space exploration. One of the most challenging risks still to be evaluated and overcome is long-term exposure to microgravity [2].

The human cardiovascular system evolved in an upright posture in a 1-g environment [2]. Leaving Earth's environment, and consequently being exposed to microgravity, causes unique stresses [2]. Normal daily physical activities that challenge the cardiovascular system to supply nutrients to working skeletal muscle are eliminated in microgravity. Living in space introduces a peculiar lifestyle that can lead to cardiovascular deconditioning and increased risk of diseases [2].

Long-term spaceflights might lead to triggering of diseases or speed up the development of pathological conditions already present.

For this reason, the experiment, aimed to assess cardiovascular mechanics in healthy and diseased structures, will benefit a lot from space conditions as consistent data useful for the planning of future long-term missions could be extracted.

Although at the moment there is no evidence that astronauts are at a higher risk of cardiovascular events with respect to civilians, the author of the studies acknowledge that there is a consistent bias deriving from the fact that astronauts are purposely trained and follow a specific lifestyle [11]. Another limitation of the cited study is that it doesn't take into account the effects of long-duration spaceflight, which other studies suggest as a risky condition [12].

It is obvious that currently astronauts are highly trained and are not selected among people who have already suffered from cardiovascular diseases. But in the near future, commercial spaceflights might include not only highly professionally trained astronauts, but also wealthy civilians who may not necessarily be healthy. In addition, since in the past only highly trained people have gone to space, the effects of microgravity on untrained individuals are unknown [13]. This experiment could help to get insights on whether having an implanted stent would constitute a condition for excluding those people or not.

As suggested, this experiment could possibly shed some light on the space use of stents if an acute medical situation would arise during a long-term spaceflight.

As shown by Chodzyński et al., gravity affects the flow in aneurysms [7]. Although microgravity is not expected to significantly affect velocity profiles in stenosis, it still has an effect on pressure drops [14]. In addition, post-stenotic areas of flow separation, since the Reynolds number is low, are the preponderant cause for pressure drop in low percent stenosis, rather than turbulence [15]. Post-stenotic recirculating areas have been highly linked to extremely severe conditions [16].

Due to the extremely low velocities, the effect of gravity might not be totally negligible.

Stents are covered by a layer of pyrolytic carbon (CarboFilm), which ensures haemocompatibility preventing platelet activation and thrombus formation [17]. Radiation exposure might damage this layer exposing the internal metal alloy, altering blood flow, inducing particles release and ultimately leading to stent failure. As radiations have cumulative effects which are visible after years, an environment with radiation levels higher than usual can constitute a test bench for predicting these long-term effects, as a significant amount of radiation exposure can be reached in a shorter period. Since space is a natural source of radiation, from this consideration, the idea of exploiting space conditions instead of performing these tests on Earth, which would require a purposely-built facility and highly complex safety measures and protocols for performing these tests.

The experiment includes ground reference models: one will be a replica of the 2U cube for direct comparison between Earth and space environment, while additional measurements will be performed exploiting the cardiovascular flow simulation test bench recently installed in PoliToBIOMedLab at Politecnico di Torino, on which one of the team members is working for her Master's Thesis.

## 5. Development of the AIM Cube

Construction of the cube was divided between the two universities due to the different facilities and expertise available. Development of the cube was divided between three sub-groups: hydraulic loop construction performed by the scientific team, mechanical development performed by the mechanical team and electronic development performed by the electronics team.

The construction of the hydraulic loop containing the pumps, arteries, tubing, fluid, sensing lines and all valves was performed in Politecnico di Torino as the lab had access to the knowledge and materials needed. The construction of the external structure of the cube, the reservoir and the testing adapter rig (for vibrational testing) was performed in ISAE-SUPAERO as the workshop in the Department of Mechanics, Structures and Materials (DMSM) could fabricate the aluminium components. The electronics board and software development were also performed in ISAE-SUPAERO due to the presence of experts in electrical engineering who could advise the team.



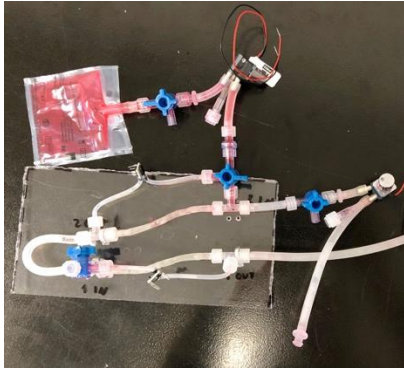

Fig. 4. Photo of the first version of the hydraulic loop

### 5.1 Hydraulic Loop Construction

As mentioned previously, the hydraulic loop was built in Turin by the scientific team: Stefano Gabetti and Elena Torta. The loop's functionality was tested throughout the process and details on the tests and the results are in section 7.

The loop contains two pumps (one for main circuit and one for dye injection), two reservoirs (one for blood-mimicking fluid and one for dye), 6 three-way valves, 2 check valves and connecting tubing. A diagram of the hydraulic loop can be seen in Figure 3.

Firstly, the pumps were selected and tested. A peristaltic pump was initially chosen for the main pump and a micropump for the dye injection. However it was found when testing the micropump that it was capable of both tasks as both the maximum pressure output (250 mmHg) and flow rate (650ml/min) were above the upper limit of the desired range. Since the micropump is much smaller and requires less power (1.62 W), it was chosen in place of the larger peristaltic pump.

Then the main circuit was built. The selected tubing has an internal diameter of 1/8" (3.2 mm). This standard value was selected as it was the closest to the physiological diameter of a human coronary artery. Initially a bubble trapper was selected for the circuit to ensure no air bubbles disrupted the experiment during flight. However, no commercial option suitable for the required flow rate could be found and no air bubbles were entering the circuit during testing so this option was discarded. The loop was built firstly without the printed coronary arteries and then once verified the artery models were added.

The dye reservoir consists of an IV bag with a volume of 50 ml, containing the dye solution. This one was obtained by mixing approximately 2.5 ml of dye and 47.5 ml of distilled water. At the time of publication a functioning circuit with dye injection functionality has been built.

### 5.2 Mechanical Construction

The mechanical design of the cube exterior and the reservoir underwent several iterations before a final design was settled upon. The cube is yet to undergo vibrational and vacuum testing therefore the current design has not been verified.

Due to the fragility of a plastic model that was initially chosen, an aluminium exterior was chosen for its rigidity and accessibility.

The current concept is an aluminium plate on which the experiment will be attached. The components will be screwed into place and glue will be applied where necessary. Once assembled the plate will be inserted inside a square aluminium tube and a lid will seal the cube.

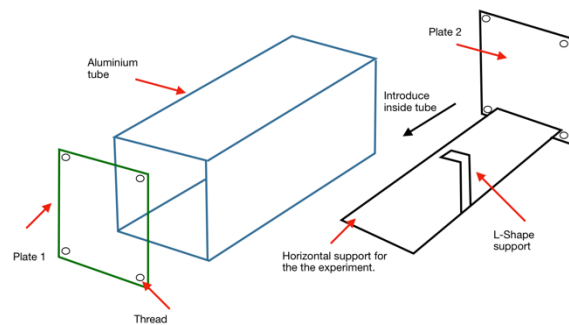

Fig. 5. Illustration of external structure assembly method

As of publication the external structure is under construction.

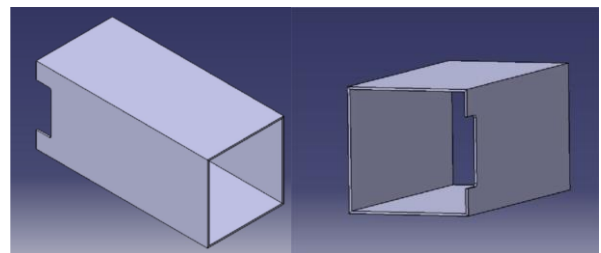

Fig. 6. 3D model of external case with slot for DB13W3 connector

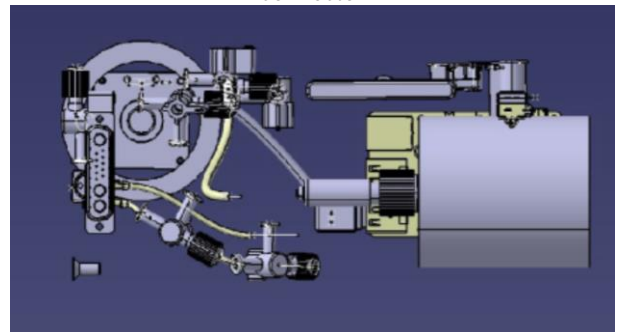

Fig. 7. 3D model of the orientation of internal components

### 5.3 Electronics Construction

The main focus during the electronics construction has been the design of the architecture system which will autonomously control the experiment once it is attached at the ICE Cubes facility on board the ISS.

The motherboard of the cube (Odroid C2) manages the cube. It controls the pump, giving the command to modify the output in order to better mimic the output flow behaviour desired. To perform different tests, different flow rates will be imposed using Pulse Width Modulation (PWM). Once a day the measurements will be taken from each sensor; thanks to the LEDs the camera will take a short video. In addition the pH sensor will measure the pH level of the fluid inside the reservoir.

A schedule was developed with the scientific team to be developed into a set of sequences that could then be commenced using telecommand. The mission will be divided into three main phases; initialisation, dye tests and non-dye tests. During the first phase all the functionalities will be tested to ensure there have been no damages endured during launch and to warm up the system. The second phase will contain all the experiments that use the dye and therefore the camera.

The tests will use different flow rates and will continue until there is no dye left in the dye reservoir. This is the most crucial phase as the main scientific data will be collected at this time. The third phase is using the time remaining to perform other experiments, using only the data collected from the pressure sensors. There is no dye injection at this phase. The phase durations are planned as follows:

- Phase 1: Week 1 of mission
- Phase 2: Week 2 to 4 of mission
- Phase 3: Weeks 4 to end of mission

Telecommands, telemetry commands and TM/TC sequences have been defined for the experiment and are in the process of being added to the experiment software.

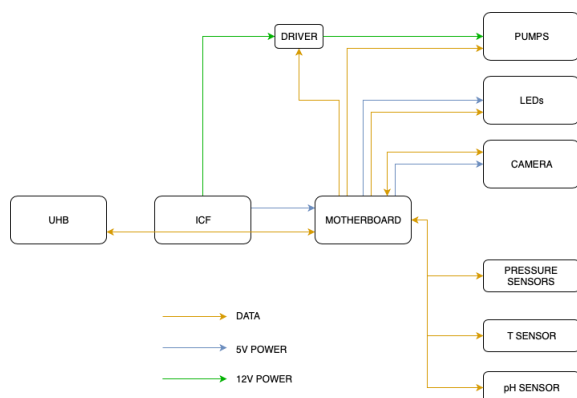

Fig.8. Electronics diagram

### 6. Testing Phase

All ICE Cubes are required to be qualified for launch. Qualification of the flight model or proto-flight model consists of the following tests:

- Full Functional Test (FFT)
- Vibration
- Vacuum
- Pre-Interface
- Interface
- Electromagnetic Compatibility (EMC)
- DC Magnetic Fields
- Audible Noise

Other tests have been performed and more are yet to be conducted. Results from the tests can be found in section 7. The FFT, pre-interface, audible noise and DC magnetic fields tests could be performed by the team on ISAE-SUPAERO premises. Evidence the cube has passed the tests must be provided to Space Applications after testing.

The Full Functional Test is performed by the team before and after all mechanical tests, transportation of the cube or any other activity that may affect the functionality of the cube. The test is designed by the team and involves testing of all electrical components and functionality of the major functions: liquid pumping, dye injection and video capture.

The estimated duration of the full functional test is 15 minutes. Since the major concern of the mechanical testing phase is the potential for leak of the fluid, the priority of the FFT is to ascertain if a leak has occurred as quickly as possible. The FFT will take place after a visual inspection, so it is assumed that no leak is visible.

The first of the mechanical tests is the vibration tests which will be conducted at ESEC-Galaxia in Redu, Belgium. Only random vibration loads will be imposed on the cube as shock and quasi-static acceleration loads are not required to qualify. The cube will be tested in the attenuated case so as to mimic the effect of the soft-stowage condition of the cube.

The following adapter rig has been designed (credit R. Carret of CSUT) and built in ISAE-SUPAERO. It will house the cube during the vibration test.



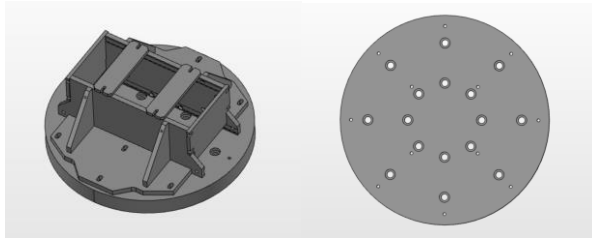

Fig. 9. Left: Aluminium adapter rig for vibrational tests without cube, Right: Aluminium base plate for installation of adapter onto shaker plate

The second mechanical test is the vacuum or depressurisation test. The level of vacuum required to qualify the cube is <100 Pa of pressure for a duration of >5 minutes. The rate of depressurisation or pressurisation is not a requirement. The vacuum test will take place in Toulouse.

The pre-interface test is to be conducted by the team on university premises and is to identify if the cube can interface with the User Home Base (UHB). It also will (pre-)verify the compliance of the Cube in terms of mechanical and electrical interface requirements (from the IRD). It must be conducted prior to the interface test.

The objective of the Interface test is to verify compatibility of the ICE Cube with the ICE Cubes Facility (ICF) on board the Columbus racks of the ISS and to verify the cube's compliance with the requirements for all experiments to be handled by astronauts on board the ISS.

The interface tests include: communication tests, end-to-end tests including cube start-up and automated procedures, physical interface checks including mating of the cube with the DB13W3 connectors and the white glove test to prevent injury to astronauts in handling.

The Electromagnetic Compatibility (EMC) tests will be conducted in Toulouse and will include testing of the cube E-field radiated emissions, B-field radiated emissions and DC Magnetic fields.

The audible noise test will take place in ISAE-SUPAERO using the university's own sonometer and anechoic chamber. The qualification level is <31dBA at a distance of <64cm or equivalently to <43dBA at <16cm.

## 7. Results

At the time of publication, the following tests have been performed:

- Dye mixing test
- Hydraulic loop functionality test
- DC magnetic fields test

The DC magnetic fields test is a requirement for all ICE Cubes experiments and the remaining tests were designed by the team in order to ensure functionality.

During the dye mixing test, a dye was made with the concentration used during flight and was injected into the blood-mimicking fluid (water/glycerol mixture). The test aimed to ensure the concentration of dye was sufficient to allow for the visualisation of the stream lines and to ascertain the maximum number of dye injection experiments can be performed. It was found that a concentration of 5% for the dye was sufficient and the total volume of dye needed is 50ml - allowing for approximately 50 experiments.

The functional test for the hydraulic loop was designed to ensure the pump was capable of reaching the desired performance and that no leaks occurred during nominal functions of the loop. The test was also intended to verify the calculated minimum volume of fluid in the reservoir. The loop was built and the pump was primed and turned to maximum flow rate. It was found that the fluid could be circulated throughout the loop with the micropump and that 100ml of reservoir fluid was sufficient whilst allowing a margin for error. Then the dye injection system was added to the main loop and initiated. It was found that the dye injection system was possible with the micropump as well and that no leaks occurred during testing.

A preliminary DC magnetic field test was conducted on the cube. The results of the test are below. Since the AIM cube contains two pumps, a DC magnetic test was performed measuring first the background and then the surface magnetic field strength at a distance of 5 cm max. from the six faces of one of the pumps, with the pump off and with the pump on. After this, the background was measured again.

Given that the requirement for an ICE Cubes experiment is for the DC magnetic field to not exceed 170dBpT (equivalent to 316µT) at a distance of 7cm, the cube has passed this test.

Table 1a. Results of DC Magnetic Fields Test (units µT)

	Background	Face +X	Face -X
Pump off	16.06	17.59	11.06
Pump on	16.06	18	10.26

Table 1b. Results of DC Magnetic Fields Test (units µT)

	Face +Y	Face -Y	Face +Z	Face -Z
Pump off	18.73	12.32	15.91	17.74
Pump on	19.46	12.86	18.16	17.24

## 8. Conclusion

Given that the cube is still under development and the testing phase is yet to be completed, there are limited results available. Ground tests will be conducted in parallel to the flight tests and the results of the experiment shall be published after conclusion of the flight. The design of the experiment and cube has been finalised and the testing phase is planned to be completed at the end of November 2019.

Once performed, the experiment aims to provide a better understanding of the haemodynamics within diseased arteries and treated arteries in altered gravity environments. The results from this experiment can thereby provide insight into how spaceflight impacts cardiovascular disease and the performance of implantable devices and may provide useful data for the planning of future long-term space missions.

## Acknowledgements

We would like to thank the sponsors of this project for their support; ESA Academy of ESA Education, Fondation ISAE-SUPAERO, AlviMedica and AIRBUS AGGUP. Special thanks to CSUT, Space Applications Services, ISAE-SUPAERO and Politecnico di Torino.

## References

- [1] *Technical package for cardiovascular disease management in primary health care*; Cataloguing-in-Publication & Hearts.; 2016
- [2] Richard L. Hughson, Alexander Helm and Marco Durante, *Heart in Space: effect of the extraterrestrial environment on the cardiovascular system*; Nature Reviews, Cardiology, Volume 15, March 2018
- [3] Herlestad, *On Linear Shift Registers with Permuted Feedback*; 1986
- [4] Xiaoyi He, David N. Ku, *Pulsatile Flow in the Human Left Coronary Artery Bifurcation: Average Conditions*; Journal of Biomechanical Engineering; 74-82; Vol.118; February, 1996
- [5] Claudio Chiastra, Stefano Morlacchi, Diego Gallo, Umberto Morbiducci, Rubén Cárdenes, Ignacio Larrabide, and Francesco Migliavacca, *Computational fluid dynamic simulations of image-based stented coronary bifurcation models*; Journal of the Royal Society Interface; 2013
- [6] R. Clayton, and D. Rodney Hose, *Excitation-contraction in the heart*; Cardiovascular Biomechanics; 107-126; 2017
- [7] K. J. Chodzyński, O. F. Eker, A. E. Vanrossomme, D. R. de Sousa, G. Coussement, L. Vanhamme, F. Dubois, A. Bonafé, B. Chopard, G.

Courbebaisse, K. Zouaoui Boudjeltia, *Does the gravity orientation of saccular aneurysms influence hemodynamics? An experimental study with and without flow diverter stent.*; Journal of Biomechanics; 49(16):3808-3814; December, 2016;

<https://doi.org/10.1016/j.jbiomech.2016.10.007>

[8] A. Molteni, Z. P. Masri, K. W. Low, H. N. Yousef, J. Sienz, and K. H. Fraser; *Experimental measurement and numerical modelling of dye washout for investigation of blood residence time in ventricular assist devices*; International Journal of Artificial Organs, 41(4), 201–212; 2018

<https://doi.org/10.1177/0391398817752877>

[9] M. Keith Sharp, *Models of the Cardiovascular System; Theory and Applications of Heat Transfer in Humans*, 2018

[11] C. J. Ade, R. M. Broxterman, J. M. Charvat, and T. J. Barstow, *Incidence Rate of Cardiovascular Disease End Points in the National Aeronautics and Space Administration Astronaut Corps*; Journal of the American Heart Association, 6(8), e005564; 2017. doi:10.1161/JAHA.117.005564

[12] Tagayasu Anzai, Mary Anne Frey, Akihiko Nogami, *Cardiac arrhythmias during long-duration spaceflights*; Journal of Arrhythmia, Volume 30, Issue 3, Pages 139-149, ISSN 1880-4276, 2014, <https://doi.org/10.1016/j.joa.2013.07.009>.

[13] C. Laing, and T. Russomano, *Short-term Exposure to Microgravity and the Associated Risk of Sudden Cardiac Arrest: Implications for Commercial Spaceflight*; European Space Agency, (Special Publication) ESA SP. 706; 2012

[14] Yan Bin Tan and Norzieha Mustapha, *Unsteady blood flow through severe stenosis in an artery under the effects of gravitational forces*, AIP Conference Proceedings 2015 1682:1

[15] D. N. Ku, *Blood Flow in Arteries*; Annual Review of Fluid Mechanics; 29(1), 399–434; 1997 <https://doi.org/10.1146/annurev.fluid.29.1.399>

[16] B. J. Kim, H. Ha, H. K. Huh, G. B. Kim, J. S. Kim, N. Kim, S.J. Lee, D.W. Kang, S.U. Kwon, *Post-stenotic Recirculating Flow May Cause Hemodynamic Perforator Infarction*; Journal of stroke; 18(1), 66–72; December 2015. doi:10.5853/jos.2015.01445

[17] Hansi, Christopher & Arab, Amina & Rzany, Alexander & Ahrens, Ingo & Bode, Christoph Hehrlein, Christoph, *Differences of Platelet Adhesion and Thrombus Activation on Amorphous Silicon Carbide, Magnesium Alloy, Stainless Steel, and Cobalt Chromium Stent Surfaces. Catheterization and cardiovascular interventions*; Official Journal of the Society for Cardiac Angiography & Interventions. 73. 488-96. 10.1002/ccd.21834; 2009.