

Solid State Lighting Panel Design and Non-Visual Effect of Light

Academic Supervisor: Professor Jussi Parkkinen

**Presented by
Bipul Mohanto**

Master of Science



**UNIVERSITY OF
EASTERN FINLAND**

School of Computing
27 October 2015

Abstract

Light has definitely a deep impact on human from the earlier time of evaluation as vision is considered the most complicated sense for human. It was a general belief for centuries that light has only visual effect as a proof of the existence classical photoreceptors rods and cones in retina. In the early 1990s, after the discovering the third novel photoreceptor called *intrinsically photosensitive retinal ganglion cells (ipRGC)* or *melanopsin containing retinal ganglion cells*, the whole concept of light effect on human has been changed and it has been proved that besides visual effect, light has also non-visual effects. The ipRGC influences human circadian rhythm by controlling the melatonin secretion directly. The process is slow but long effective on our everyday life. For a normal human the circadian rhythm is the biological clock of 24 hours sleep wake cycle.

Each of these three photoreceptors has its own most sensitive region in photometry. The rods and cones have their peak sensitive region around 505 nm and 550 nm respectively and the ipRGC has its sensitivity peak in 460nm–480 nm range. As an electric light, solid state lighting (SSL) is taking place over all other traditional electric lights for its high luminous efficiency. Nowadays most used white light emitting diode (LED lamps) generates its peak wavelength also in this range where the ipRGC is most sensitive. Problem often occurred for those people who spend most of their time under this artificial light environment. It causes irregular circadian rhythm, sleeping disorders and other psycho-physical problems. So design and installation lights in such an environment like commercial offices is very significant considering the non-visual effects of light.

On the other side, energy consumption is also very important for both commercial and domestic buildings. It has economical, environmental and social values as well. A good combination of daylight and electric light gives better outcomes in non-visual effects on human at a commercial building. Consideration of the non-visual effects, daylight measurement for green buildings and light emitting diodes-these are the three key words of this whole thesis work.

The main thesis work has been conducted with literature review following the similar research in this field with general understanding of the non-visual effects on human. The relevant lighting measurements and LED panel design methodology have been studied carefully to further development of the panel. The daylight data has been recorded over a four months period of time, from February to May according to the month change also focusing on the seasonal change from late winter to spring. The data measurements have been conducted in two different locations; first location is outdoor and second location is an open exterior area. The data has been analyzed and documented properly for future research purposes. Finally, five different LED panels have been designed where the irradiance values are first normalized and then optimized according to the highest Circadian Action Factor (CAF) and melanopic-lux values. Different LED matrix patterns have been applied with the available LED packages to gain the best illumination outcome and color rendering properties.

Acknowledgements

I am really honored to have this great opportunity to express my true and sincere gratitude to many people without whom it would not be possible to continue and finish this thesis work in proper time. I feel myself rich with great feelings of having such people who were always supportive to make my focused thesis work fulfilled, flourished and prosperous.

First of all, I would like to thank my respected thesis supervisor, Professor Jussi Parkkinen. It was his consistent guidance, support, advice and enthusiasm which made me accomplished in this work. Without his guidelines, criticism, and unwavering support, the smooth continuation of this work would be very difficult as well as finishing it in proper time limit. Many thanks to Professor Markku Hauta-Kasari and Ville Heikkinen for their priceless criticisms and comments during two mock thesis presentations helped me make proper correction, modification and update of my work in a new stream. They will always remain as inspiration for me. I want to thank Piotr Czesłowski Bartczak, for providing his cordial helps, advises and guidelines with the measurement devices, light booth setup, let me using his developed GUI and suggestion towards the LED panels development on my work whenever I asked for. I have to mention my fellow friends and classmates, Richa Sharma and Glenn Sweeney who were always keeping our room dynamic to work on.

Special thanks Dr. Vineetha Kalavally and You Jin Tam from Monash University, Malaysia for their kind assistance about research and data related to LED light optimization. I am really grateful for sharing their research with me. Various figures and tables are being adopted from various scientific journals, magazines and blogs with appropriate mention, I am grateful and showing my gratitude to all of them with honorable mention.

At the end, I want to thank my parents who are my best support, inspiration, and motivation of life. Last but not the least, I want thank the Almighty for this path of my life and the given ability to flourish it for upcoming future.

Contents

| | |
|--|------------|
| Abstract | ii |
| Acknowledgements | iv |
| Contents | vi |
| List of Figures | vii |
| List of Tables | x |
| 1 Introduction | 1 |
| 2 State of the Art in Light Research | 3 |
| 3 Methodology | 5 |
| 3.1 Solid State Lighting | 5 |
| 3.2 Non-Visual Effects of Light | 7 |
| 3.3 Radiometry and Photometry | 9 |
| 3.4 Standard Illumination Level in Office Environment | 9 |
| 3.5 Outdoor Light Measurement Method | 11 |
| 3.6 Open Exterior Area Light Measurement Methods | 11 |
| 3.7 Indoor Light Measurement Methods | 12 |
| 3.8 Regular Area with Symmetrically Located Single Luminaire | 13 |
| 4 Experiments, Results and Discussions | 14 |
| 4.1 Daylight Irradiance Data Acquisition | 14 |
| 4.2 Measurement Optical Devices | 15 |
| 4.3 Outdoor Daylight Irradiance Data Acquisition | 16 |
| 4.4 Outdoor Daylight Irradiance Data Analysis | 17 |
| 4.5 Open Exterior Daylight Irradiance Data Acquisition | 19 |
| 4.6 Open Exterior Daylight Irradiance Data Analysis | 19 |
| 4.7 Light Booth Setup for LED Panel Testing | 20 |
| 4.8 Basic Structure of LED Package | 23 |
| 4.9 Pre-LED Panels Designing Work | 24 |
| 4.10 Designing LED Panels | 26 |
| 4.11 RGBA Column Matrix Pattern LED Panel | 26 |
| 4.12 RGBA Circular Matrix Pattern LED Panel | 27 |
| 4.13 RGBA Randomized Circular Matrix Pattern Panel | 29 |
| 4.14 13 LED Circular Panel for Maximum and Minimum Melanopic Lux | 31 |
| 4.15 LED Panel Quality Testing | 33 |
| 4.16 Average Illumination (\bar{E}_h) in Horizon Level | 33 |
| 4.17 Color Rendering Index (Ra) | 34 |
| 5 Conclusion and Future Research | 35 |
| Bibliography | 36 |

List of Figures

| | | |
|----|--|----|
| 1 | LED diodes emit light through a p-n junction. At the case of forward biased, excited electrons from n-type silicon combine with the holes in the p-type silicone emit photons of light. Normally LED diodes only emit one dominant wavelength light. Reference: <i>Scientific Instruments Blog</i> , August 15, http://www.imagesco.com/articles/photovoltaic/photovoltaic-pg4.html | 6 |
| 2 | The pineal gland is in the middle of the brain. It produces hormones that control routine activity, such as melatonin, which regulates the body's wake-sleep cycle. Reference: <i>Human anatomy blog</i> , August 14, 2015 http://history.wisc.edu/sommerville/351/351-19.htm | 8 |
| 3 | The visual and non-visual pathway of light in brain, reference: "The Physiological Impact of Lighting, OSRAM, page 7". 12th annual DOE Solid-State Lighting R&D Workshop, January 27–29, 2015. San Francisco, USA | 8 |
| 4 | Human visual sensitivity is primarily in the green and yellow part of the spectrum and is depicted by the thin solid line. Circadian rhythms are controlled by light emitted within the dashed curve. The color of light emitted by a typical bluish-white 5500 Kelvin LED is depicted by the bold line. A large portion of light emitted by this light source falls outside of the human photopic vision range, and falls within the circadian rhythm curve. IDA recommends limiting blue light emitted below 500 nm, as indicated by the shaded section of the graph. Reference: "international dark sky association blue light at night threatens animals and people", Craig DiLouie, January 20, 2010, http://www.lightnowblog.com/ | 9 |
| 5 | Regular area with symmetrically located single luminaire measurement terminals. The square solid line represents the area where the luminaire position is at the middle of the circle. <i>p1, p2, p3, p4</i> are the measurement terminals | 13 |
| 6 | Measurement devices, (a) Gigahertz-Optik-BTS256-LED Tester (b) Konica Minolta Illuminance Spectrophotometer CL-500A, (c) Konical Minolta Chromameter CL-200 | 15 |
| 7 | (a) the vertical and horizontal measurement directions w.r.t. the eye position, (b) the vertical measurement direction w.r.t. the sensor position, (c) the horizontal measurement direction w.r.t. the sensor position | 15 |
| 8 | Outdoor daylight measurement location; (a) the vertical measurement according to the device sensor position (b) the horizontal measurement in south cardinal point (c) the horizontal measurement in west cardinal point (d) the horizontal measurement in north cardinal point (e) the horizontal measurement in east cardinal point; the height has been selected according to the eye position | 16 |
| 9 | Vertical irradiance change over four months period of time; blue, green, yellow and red solid lines are for February, March, April and May respectively at 12 pm. Blue, green, yellow and red broken lines are for February, March, April, and May respectively at 4 pm | 17 |
| 10 | North directional irradiance change | 18 |
| 11 | South directional irradiance change | 18 |
| 12 | East directional irradiance change | 18 |
| 13 | West directional irradiance change | 18 |

| | | |
|----|--|----|
| 14 | Horizontal irradiance change over four months period of time in four cardinal directions: north, south, east, and west in outdoor location. The blue, green, yellow and red solid lines are for February, March, April, and May respectively at 12 pm, blue, green, yellow and red broken lines are for February, March, April, and May respectively at 4 pm | 18 |
| 15 | Open exterior daylight measurement location; (a) the measurement location is at the fifth floor in Network Oasis tower that is shadow free from nearby buildings (b) according to the position of the south facade window, the south and north horizontal measurement directions (c) the west cardinal horizontal measurement direction (d) the east cardinal horizontal measurement direction | 19 |
| 16 | North directional irradiance change | 20 |
| 17 | South directional irradiance change | 20 |
| 18 | East directional irradiance change | 20 |
| 19 | West directional irradiance change | 20 |
| 20 | Horizontal irradiance change over four months period of time in four cardinal directions: north, south, east and west in open exterior area location. | 20 |
| 21 | The light booth setup according to the LED panel position | 21 |
| 22 | IES average illumination measurement method | 22 |
| 23 | True average illumination measurement method | 22 |
| 24 | True average illumination level measurement technique | 22 |
| 25 | The cross section of a LED package shows a typical high-brightness 1 Watt LED and its associated thermal system configuration [64] | 23 |
| 26 | Irradiance values of 32 LED Packages | 25 |
| 27 | RGBA column matrix pattern LED panel designing visualization. | 27 |
| 28 | RGBA column matrix pattern LED panel spectrum, blue and green line is target spectrum and gain spectrum respectively. | 27 |
| 29 | RGBA circular matrix pattern LED panel, red, green, blue and amber color represents relevant LED packages respectively. | 28 |
| 30 | RGBA circular matrix pattern LED panel spectrum, blue solid line is the target spectrum, green and red line are the gain spectrum without and with diffuser respectively. | 29 |
| 31 | RGBA randomized circular matrix pattern LED panel, each of the color represents relevant LED packages, blue circle in amber triangle means the randomized position of blue LED package in amber LED package in 1:3 ratio. | 30 |
| 32 | RGBA randomized circular matrix pattern LED panel spectrum, blue line is the target spectrum, green and red lines are gain spectrum without and with diffuser respectively. | 30 |
| 33 | 13 LED circular matrix pattern panel | 32 |
| 34 | 13 LED circular matrix panel spectrum, the dominant wavelength colors have been given in the left figure. The nearby dominant wavelengths have been kept together after using the opponent color theorem | 32 |

List of Tables

| | | |
|----|--|----|
| 1 | Commercially used doped semiconductors to generate different color of light . . | 7 |
| 2 | Radiometric and photometric units [J = Joule; w = watt, lm = lumen, sr = steradian, cd = candela, m = meter, lx = lux] | 9 |
| 3 | National standards illumination level in 5 different places, European continent, USA, Japan, Russia, China | 10 |
| 4 | The foreground and background illumination level given in lux units. As for example, if the main task area illumination is 500 lux, the surrounded area illumination should be 300 lux for visual comfort. | 11 |
| 5 | Peak wavelengths for all 32 tested LED packages | 25 |
| 6 | RGBA column matrix pattern, the LED packages that have been used with manufacture number, color of the package, dominant wavelength and total number those have been used. | 26 |
| 7 | RGBA circular matrix pattern LED panel design, used LED packages with manufacture number, color, dominant wavelength and total number that have been used. | 28 |
| 8 | RGBA randomized circular matrix pattern LED panel designing with the manufacturer number, color, dominant wavelength in nm and number that have been used for each of the packages | 29 |
| 9 | 13 LED circular matrix panel designing, the manufacture number has given with the dominant wavelength and dominant color with the LED packages used for each of the class. The irradiance values have been controlled with the GUI developed with MATLAB | 31 |
| 10 | 13 LED panels' CAF and Melanopic-Lux values for 8 different iteration steps are given here. Among these 8 different iterations, the first row and the last row melanopic lux values which are the highest and lowest values are taken into action for designed LED panel testing | 31 |
| 11 | Gained illuminance level (IES average illumination and true average illumination), the illuminance level are given in lux unit. | 33 |
| 12 | The uniformity of the table surface at different measurement terminals p1, p2, p3, p4 without and with diffuser; the uniformity as been measured in four different measurement points in lux unit | 34 |
| 13 | Color rendering indexes for different LED panels | 34 |

1 Introduction

The concept of light has been dramatically changed over last few years in both commercial and research world. Nowadays the foremost challenges to light designers are to make it more commercially profitable, pleasant to the end-users, improve the general situation of light-health factors, increase the productivity, as well as environment friendly in terms of green world. In a congested high-rise commercial urban area, where many multi-storied buildings or skyscrapers are standing in the shortest possible distance from each other, the direct daylight can hardly reach the working space of the occupants. In that scenario, the daylight reflected from the nearby building surfaces is mostly the only one natural way to lite a commercial building indoor space. In most of the cases the received illumination is not enough due to the nature of work. So the necessity of artificial lighting sources, like electric lamps are the only alternative option.

The reflected or direct daylight enters into a building's indoor space especially through the window facades. Daylight is obvious for both domestic and commercial buildings as it makes the entire environment more affecting, visually comfortable for the occupants to balance their circadian rhythm, improve their both physical and mental health. Research found that human body functions are more active under certain period of active daylight [1]. In other way, daylight has a good color rendering property than the artificial electric lights. The illumination level is also very high under different sky conditions around the year than the general electric lamps illumination level [2].

Another benefit of using daylight is that it saves a lot of electric energy, that must be profitable for any commercial building owners. Research found that around 20%–30% of total electricity has been used for lighting a fully air-conditioned commercial building. In terms of a domestic building, the electric saving possible by using daylight is upto only 10% annually [3].

To minimize the use of electricity and to develop the indoor lighting condition, the U.S. Green Building Council (USGBC) has standardized “Leadership in Energy and Environmental Design (LEED)” standards for building planners, architects and light designers. Under these standards new buildings are being designed, old buildings are being converted and moreover regulated intensively and researched for further development. The main purpose of these standards are to use the daylight in smarter and more effective way to reduce the electric consumption and improve the indoor building environment.

For designing and developing a green building, the first most important perquisite is knowing the outdoor daylight condition and its changing pattern (irradiance) around the seasonal change of the year. Second most important factor is finding the “Useful Daylight Illuminance (UDI)” [4]. Under the UDI, the hourly illumination values are being measured and categorized into three different classes, 0-100 lux, 100-2000 lux and over 2000 lux in horizontal illuminance level [5]. It has been found that any illuminance over the upper threshold value 2000 lux is not useful due to potential overheating condition [5].

Another disadvantage of using direct daylight is the sun glare, can make the environment unpleasant to the occupants [6] especially when the working station located beside the windows. The availability of daylight is also not regular, and it depends on the altitude of sun position, changes during different seasons of the year. The sky conditions and weather of a particular time also has deep impact on the regular daylight availability.

Keeping this daylight measurement factors in consideration and for further research purpose, the daylight data has been recorded over the months from February to May in two particular locations in Joensuu, Finland. This time period also gives us the changing pattern of daylight

over seasonal change from late winter to spring. The data has been modified and analyzed to visualize the changing pattern clearly during this time period.

For a good indoor lighting condition, most of the commercial buildings nowadays are being lighted by either compact fluorescent lamps (CFL) or light emitting diodes (LED) for their high luminous efficiency. Although both of the commercial lights have almost equal color rendering properties, considering the high luminous efficiency and longevity over CFL, LED lamps are taking the market rapidly [7]. LED is a solid state lighting source that uses electroluminescence properties of semiconductor diodes to generate electricity. About the properties of natural daylight, it contains around 5% ultraviolet, 45% visible range spectra, and rest 50% infrared ray [4]. Electric lamps like incandescent and compact fluorescent lamps generate a noticeable range of infrared rays, where the LED lamps cover only the short visible range of light from 380 nm-780 nm, made it more energy saving.

This short range of spectrum often generated by LED lamps also have some serious health concerns. The commercial LED lamps (especially white light) often generate peak wavelength in the bluish region and the ratio of ultraviolet, visible spectra and infrared rays also different than natural daylight [8]. A regular natural daylight pattern controls human circadian rhythm of 24 hours sleep wake cycle normally. Designed electric lights like LED lamps often proved hazardous to this normal circadian rhythm. In the same region of dominant blue peak of LED lights the intrinsically photosensitive retinal ganglion cells (ipRGC) are also sensitive and this overlap often creates health problems [9].

During this thesis work, besides the daylight measurement five different LED panels have been designed and developed considering the non-visual effects of light on circadian rhythm with the available LED packages in the laboratory. The panel design has been taken into account a long experimental setup and testing in the laboratory light booth. Optical devices like Konica Minolta Spectrophotometer CL-500A, Chromameter CL-200 and Gigahertz Optik BTS256-LED Tester have been used for different stage of light quality measurements.

About the structure of this thesis, in first part it has been focused on the problems of such lighting research, state of arts, and similar research works that have been carried out previously, their findings with the name of literature review. During daylight measurements and LED panel designing, these research works have been followed carefully. Second part is the methodology, where first the solid state lighting, then non-visual effects of light and its pathway from retina to human brain as well as its effects have been described with visual illustration. The radiometry, photometry and their units with standard illumination level for an office environment in different countries are mentioned with the reference next. Then the discussion continues about different location's light measurement methods such as outdoor, open exterior area and indoor depend on the surface area the light that covers that area, position of the luminaire and their advantages and disadvantages. At the third part the finding of this thesis work have been illustrated with experimental setup, results and appropriate discussions. Finally a short conclusion about the future work that can be carried out based on the collected data and built in setup as an elaborate version of this thesis for better development has been highlighted with few words.

2 State of the Art in Light Research

The solid state light output quality depends on the appropriate conversion of electricity to visible white light (380 nm-780 nm) using semiconductor materials where each of the semiconductor materials has unique properties. By taking advantage of direct electricity to light conversion rather than the processes in which light is the by product of another conversion As with traditional incandescent lamps and compact fluorescent lighting, it promises unprecedented, and under appropriate situation until 100% conversion efficiency.

Nowadays solid state lighting industries, however requires more improvement to achieve such conversational efficiency. The logic behind this is to become the standard light source of the 21st century, conversion efficiency must be improved while simultaneously achieving low cost but high quality output. It is also very important establishing the solid relation of human visual experience with the light perceived, as indirectly it creates deep impact on human hormonal functions controls whole bodily functions. The relation should be almost similar to that daylight to omit any hazardous effect.

High quality white light is possible with a combination of many (e.g., red, amber, yellow, green, and blue) colors, with different intensities and irradiance values [10]. Appropriate color mixing methods are intensively designed with the light emission properties in this lighting design. Successfully addressing these two challenges promises to enable energy efficient, cost effective, high quality white light that will save energy and benefit the human psycho-physical health and improve circadian factors.

The daylight condition is not constant all over the year, it is a variable depends on the sun altitude at different time of the year. The sun altitude also controls the seasons and weather in a particular geographic area. Similar daylight measurement carried out in Naples, Italy during two main seasons of the year, summer and winter. The measurement terminal location is indoor at three different office spaces with different exposures, characteristics and setup. The main goal of that research was to find the outcomes how during summer time in a working desk height the available illuminance creates impact on the employees' circadian factors. Then it has been compared with the recorded data and subjective experiment in the same location during winter. The findings are surprising, although outdoor daylight situation was different, the spectral power distribution and correlated color temperature (CCT) in eye level found almost constant for an office environment due to the presence of electric lamps and the good combination of electric light with daylight arriving throw the windows. Different parameters like outdoor different sky conditions, seasonal change, room dimensions, and surface spectral reflectance factors are taken into account. Another novel finding was although the CCT values are different, the irradiance received by the eyes and its related circadian impact on human are almost similar to CIE standard illuminant D50 and D55 as tested[6].

To improve the planning of domestic apartments considering the luminous comfort, that directly controls residence behavior, research has been carried out under the Department of Building Services Engineering, at The Hong Kong Polytechnic University [11]. The research has been carried out with statistical method interviewing 340 residents inhabit in both public and private housing. The goal was to find how luminous comfort and uniformity of daylight controls human behavior patterns. The degree of luminous comfort highly affected by the good-day light condition. The use of electric lights for longer period has a deep impact on inhabitants luminous comfort, especially during a poor daylight condition.

Similar light measurement techniques have been used by Hideaki Kido *et al.* [12] in an office

building in order to find the indoor lighting characteristics with respect to the outdoor daylight condition. In the experiment they used two light shelves, first one is only a light shelf and second one is a light shelf with a blind in terms of horizontal illuminance and window luminance. The same lighting measurement configuration is used during this thesis work at the open exterior area where in spite of light shelf in horizontal direction, we have compact fluorescent lamp exists in vertical direction in north side¹⁵ with a combination of daylight coming through a south facade window. Their finding about the research work that the presence of light shelf increases the ceiling level illuminance, especially during the winter season in Japan, the illuminance level was noticeable when during summer it was more consistent than any other season. Like these experiments, the illuminance level has a dramatically change found in my open exterior data analysis due to the compact fluorescent lamps presence in open exterior area described in section 4.6.

During this thesis work, different LED panels have been intensively designed straightly followed by the light design models from Monash University, Malaysia [13]. To ensure the light quality, especially the white light output generated by *additive color mixing* was compared with the light output from Monash University. The system that has been used at that University is different than the system that has been developed during my work. Already built-in system with automatic controlled system has been used there where in my setup everything was manual, each of the parameters, like intensities, irradiance have been controlled separately. The light testing work has been carried out according to the four characteristics of the generated white light; naturalness, attractiveness, brightness and preference compared with a standard white LED light source. The white light spectrum using the RGB LEDs has been optimized based on its tristimulus values compared with the CIE reference illuminant D65 [14].

3 Methodology

In this chapter, first it has been given a short overview of solid state lighting (SSL), its advantages and disadvantages. Then a short description has given on the biological path way of non-visual effects from retina to human brain and related hormonal function activities that control our daily bodily functions. It has been tried to figure out the differences between visual and non-visual effects of light. Discussion about the radiometry and photometry has taken place next, in all the measurements and experimental setups that have been carried out during this work is being used the photometric units only that has been given in this section. Then a general discussion about standard illumination levels for an office environment in different countries determined by different national and international organizations has been showed up with illumination values. In this discussion two different economical categories countries are mentioned, where Europe, USA and Japan are considered as developed and Russia, China are considered as developing countries. It has been tried to figure out how the economy controls standard lighting conditions. In next section different light measurement methods that have been used at three different locations, outdoor, open exterior and indoor has been discussed elaborately.

3.1 Solid State Lighting

The solid state lighting (SSL) is a source of light energy created by semiconductor electroluminescence materials where in traditional light sources filament, gas or plasma are being used to produce light energy[15]. After the first commercialization in early 1960s, the solid state lighting industry is blooming tremendously replacing all kind of traditional light sources because of its multi-purpose use, that can be applied easily from road side billboard to complicated electronic displays. The main advantages of using solid state lighting is its luminous efficiency, longevity, high color rendering indexes[16]. The solid state lighting can be classified into three major classes depending on the semiconductor materials that have been used in it[17],

1. Light Emitting Diode (LED)
2. Polymer Light Emitting Diode (PLED)
3. Organic Light Emitting Diode (OLED)

In a solid state lighting, semiconductor materials are being used. Semiconductor materials have an electrical conductivity value in the middle of the electrical conductivity range of conductors like different kind of metals and insulators like glasses [18]. Another property of semiconductor is when applying temperature reduces the electrical conductivity of conductors, in semiconductor electrical conductivity increases with the increase of temperature dramatically[18]. This behavior is totally unique compare with any other chemical elements.

Electricity conduction in a semiconductor material takes place through the movement of free electrons and holes, plays the role of charge carriers. Adding a very few amount of impurity atoms to a semiconducting material, known as doping, rapidly increases the number of charge carriers within it [21]. When a doped semiconductor contains mostly free holes it is called *p-type* or positive type, and when it contains mostly free electrons it is known as *n-type* or negative type doped semiconductor. The semiconductor materials used in electronic devices are doped under precise conditions to control the concentration and regions of p and n type dopants. A single semiconductor crystal can have many p and n type regions. The p–n junctions (1) between these regions are responsible for the useful electronic behavior [22].

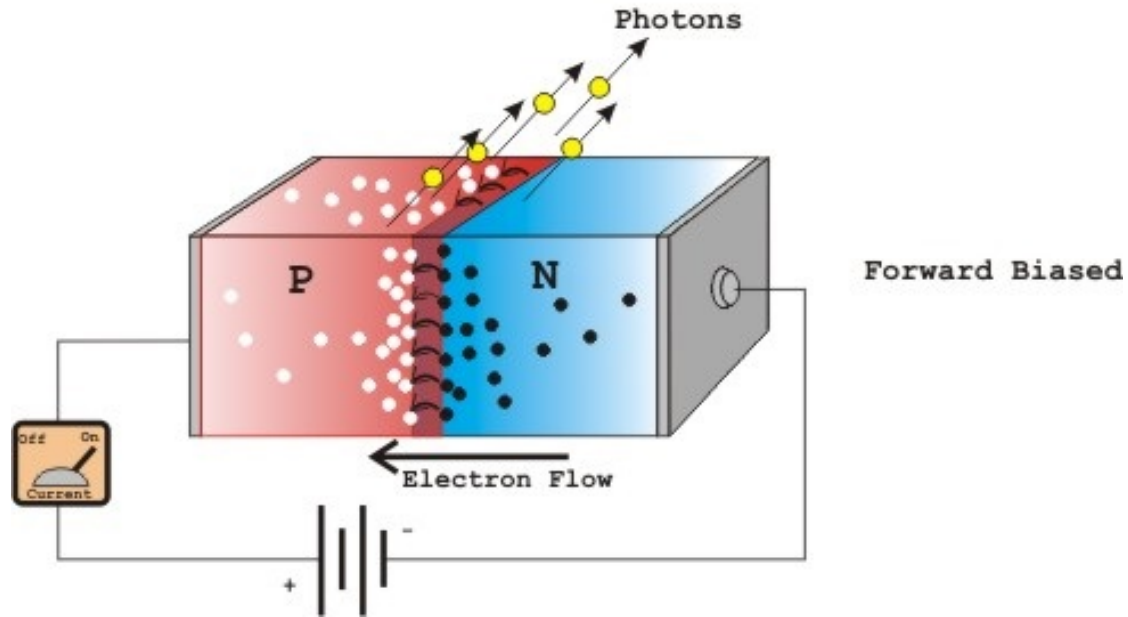

Figure 1: LED diodes emit light through a p-n junction. At the case of forward biased, excited electrons from n-type silicon combine with the holes in the p-type silicone emit photons of light. Normally LED diodes only emit one dominant wavelength light. Reference: *Scientific Instruments Blog, August 15, <http://www.imagesco.com/articles/photovoltaic/photovoltaic-pg4.html>*

In a semiconductor material how much energy will be generated as light with peak wavelength depends on band gap or energy gap (E_g). The band gap generally refers to the energy difference (electron volts, eV) between the valence band and the conduction band. Electrons either can stay in the valence band or conduction band but not in the band gap region. If the semiconductor come to outsource electric connection, some electrons get the energy to transfer from the valence to the conduction band. Excited electrons emits energy at the conduction band and return to the valence band, this energy is emitted as light energy. Depends on different size of band gaps in different semiconductor material, light energy with different peak wavelength is emitted [19]. The energy emitted by the electron can be determined by Planck's formula,

$$E_2 - E_1 = h\mu_{21}$$

Where,

E_2 = Energy associated with the conduction band

E_1 = Energy associated with the valence band

h = Planck's constant

μ = Frequency of the emitted radiation as the electron moves from conduction band to valence band

A relation can be established between dominant wavelength and energy emission in electron volt in a semiconductor material using the following formula[20],

$$\text{wavelength} = \frac{1239.76}{V_d} \text{nm}$$

Where,

V_d = potential difference in electron volts (eV) between two energy band (valence band and

conduction band) through which the displaced electrons has fallen in one transition.

The chemical elements in column III and V in periodic table are used for doping a pure semiconductor materials [23]. In table1 the commercially used doped elements have been showed along with the ultra pure semiconductors to produce different color LED packages with their approximate expected peak wavelength[24]. It is noticeable that same kind of elements can be used to generate different dominant wavelength with very few varies in the amount of impurities. For example, same *InGaN* can be used to generate 450 nm blue, 500-505 nm blue-green or 525 nm green dominant wavelength light. Here the amount of impurities is different according to its application. Same like that, *AlInGaP* can be used to generate 590 nm amber, 605 nm orange, 615 nm orange-red or 625 nm red dominant light[25].

| Element Conjugation | Peak Wavelength (nm) | Color Emits |
|---------------------|----------------------|-------------|
| <i>InGaN</i> | 450 | Blue |
| <i>InGaN</i> | 500, 505 | Blue-green |
| <i>InGaN</i> | 525 | Green |
| <i>AlInGaP</i> | 590 | Amber |
| <i>AlInGaP</i> | 605 | Orange |
| <i>AlInGaP</i> | 615 | Orange-Red |
| <i>AlInGaP</i> | 625 | Red |

Table 1: Commercially used dopped semiconductors to generate different color of light

3.2 Non-Visual Effects of Light

Human eyes mostly play dual role to optical radiation, the first role is image forming or visual effects and the second role is circadian, neuro-endocrine, neurobehavioral responses known as non-visual effects[26, 27]. The word circadian originated from the Latin word “circa-diem” means “approximately a day”. A complete rotation of the earth on its own axis takes exactly 24 hours (more precisely 23 hours 56 minutes 4.1 seconds), called a complete day. The light-dark cycle of a day is very important for performing our daily bodily process such as sleep-wake circle, the heart rate, bodily temperature, production of certain kind of hormones. This 24 hours body cycle is known as circadian rhythm. The non-visual effects can be profound for human health and well being as it controls human sleep-wake cycle.

It was the general belief that rods and cones are only light sensitive photoreceptors in human retina until the year 2000 when scientists have discovered that around 1% (the range has been found varies from person to person minimum 0.2% to maximum 0.8%) of the retinal ganglion cells are also sensitive to light. This ganglion cells are called intrinsic photosensitive retinal ganglion cell (ipRGC)[9, 28, 29, 30]. The ipRGC photoreceptors have a direct connection with biological clock located at human brain called Suprachiasmatic Nuclei (SCN)[31]. SCN has connection with pineal gland[32] that produces many active hormones for human body (fig.2).

The ipRGC expresses directly the photo-pigment melanopsin that is responsible for the non-visual functions in a circadian rhythm[33, 34]. In a regular circadian rhythm two important kinds of hormones are produced in human body called cortisol, also known as energy hormone and melatonin, also known as sleeping hormone. In the morning the level of cortisol is full gives human body energy to work and concentration. With the increase of time, the level of cortisol started dropping and before sleeping the level becomes minimum. Melatonin works in the total opposite way of cortisol. In the morning after getting up, the level of melatonin is in minimum level but as the day time starts increase, the level also starts increasing, before sleeping the level is maximum causes sleeping for human being. The circadian rhythm is not only present in human body, but also present in many other animals, plants even in bacteria and low level algae.

From the human retina to brain we have two path ways[35, 36]. In fig.3, the green solid

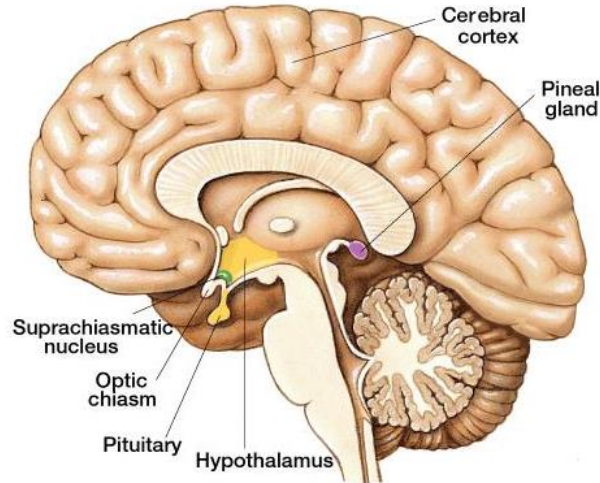

Figure 2: The pineal gland is in the middle of the brain. It produces hormones that control routine activity, such as melatonin, which regulates the body’s wake-sleep cycle. Reference: *Human anatomy blog, August 14, 2015* <http://history.wisc.edu/sommerville/351/351-19.htm>

line represents the visual path way and the blue solid line represents the biological functional (non-visual effects) path way that is directly connected with the suprachiasmatic nuclei (SCN) and pineal gland. As like the other photoreceptors, rods and cones, the ipRGC is sensitive in a particular region in the sensitivity curve. When the normal photopic vision is mostly sensitive in the yellow-green region (530 nm-550 nm), the non visual effect is sensitive to mostly in blue region, in the range of 460 nm to 480 nm in electromagnetic range.

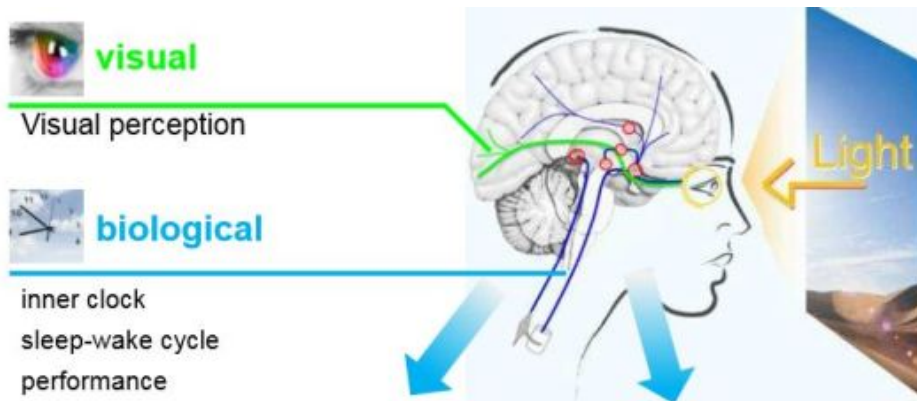

Figure 3: The visual and non-visual pathway of light in brain, reference: “*The Physiological Impact of Lighting, OSRAM, page 7*”. 12th annual DOE Solid-State Lighting R&D Workshop, January 27–29, 2015. San Francisco, USA

Figure 4 adapted from LEDs Magazine [37], showing the difference between circadian curve and photopic vision curve compare with present bluish-white LED luminaries. Commercially this bluish-white LED luminaries are being used most. From this figure it can be seen the circadian sensitivity curve has the peak in around 460-480 nm, blue rich LED has the peak in almost in the same zone [38].

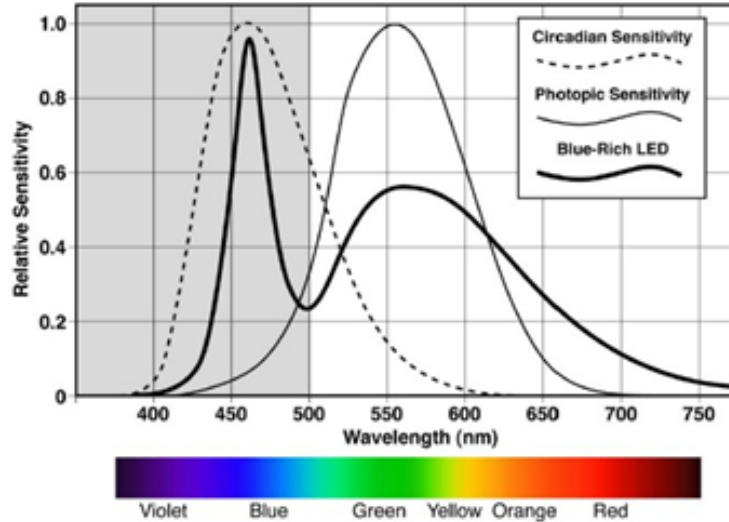

Figure 4: Human visual sensitivity is primarily in the green and yellow part of the spectrum and is depicted by the thin solid line. Circadian rhythms are controlled by light emitted within the dashed curve. The color of light emitted by a typical bluish-white 5500 Kelvin LED is depicted by the bold line. A large portion of light emitted by this light source falls outside of the human photopic vision range, and falls within the circadian rhythm curve. IDA recommends limiting blue light emitted below 500 nm, as indicated by the shaded section of the graph. Reference: “international dark sky association blue light at night threatens animals and people”, Craig DiLouie, January 20, 2010, <http://www.lightnowblog.com/>

3.3 Radiometry and Photometry

Radiometry is the measurement of optical radiation of electromagnetic wave starting from the cosmic ray (0.01 micrometer) to ultrasonic wave (1 millimeter)[39] where photometry is the measurement of light with only the limited band of electromagnetic wave (approximately 380 nm to 780 nm). This short range is only sensitive to human vision system.

During this thesis work, only photometric units are being used. Because all of the experimental measurements are being measured in human visible range[40]. Given below the table 2 showing the difference between radiometric units and photometric units.[41, 42]

| Quantity | Radiometry | | Photometry | |
|--------------------------|----------------------|-----------|---------------------------|---------------------|
| | Parameter | Unit | Parameter | Unit |
| Energy | Q | J | Q_v | J |
| Power | Radiant flux, P | w | Luminous Flux, Φ_v | lm |
| Power/solid angle | Radiant intensity, I | w/sr | Luminous intensity, I_v | cd = lm/sr |
| Power/unit area | Irradiance, E | w/m^2 | Illuminance, E_v | lx = lm/m^2 |
| Power/ area/ solid angle | Radiance, L | w/m^2sr | Luminance L_v | $lm/m^2sr = cd/m^2$ |

Table 2: Radiometric and photometric units [J = Joule; w = watt, lm = lumen, sr = steradian, cd = candela, m = meter, lx = lux]

3.4 Standard Illumination Level in Office Environment

Like any other branch of scientifically measurement, the illumination conditions at different situations and locations also have standard scales followed by the light designers, architects and engineers. The recommended standard of illumination depends on 3 different conditions

determined by the International Commission on Illumination in their 2010 annual report. The 3 conditions are,

1. need of individual
2. need of the society
3. need of the environment

The individual needs are designed for different parameters like visual performances, visual comfort, color appearance, well-being, and non-visual effects. The non-visual effects are considered carefully by the standards of spectral power distribution (SPD), daylight factor (DF), daily exposure to daylight, frequency of the light that is being used, ultraviolet (UV) and infrared (IR) amount in the light. Society needs are cost, budgets, public satisfaction, productivity, low maintenance cost, security, safety issues and considering less fatigue of citizens. Environment needs requires less light pollution, low power consumption, reduction of harmonics and power losses, reduction of hazardous elements used to produce electric lamps[43]. Depending on various needs, table 3 illustrates the standard office illumination level in 5 different countries, the illumination levels are determined in lux unit.

| Countries | Conference Room | Normal Working Desk | Drawing Table | Archive Room |
|--------------------------|---------------------------------|--------------------------|----------------------------------|--------------|
| Europe [CIE 12464-1] | 500 | 500 | 750 | 200 |
| USA [ANSI-IESNA-RP-1-04] | \bar{E}_h 300, \bar{E}_z 50 | 100-1000 | \bar{E}_h 1000 \bar{E}_z 500 | 150 |
| Japan [JIES-008(1999)] | 300 | $750 < \bar{E}_h < 1500$ | $\bar{E}_h > 750$ | 200 |
| Russia [SNiP-23-05-95] | 300 | 300; 200-400 | 500; 400-600 | 75; 50 |
| China [GB-50034-2004] | 300 | 500 | 500 | 200 |

Table 3: National standards illumination level in 5 different places, European continent, USA, Japan, Russia, China

In the table above, the first three countries are considered as developed countries and last two are developing in status of economic growth. Like in Europe and other developed countries average standard illumination level is 500-550 lux in horizon level. USA is the only one country that has standards both in the horizon and vertical direction separately. For Russia more light is reserved depending on the specific requirements. In that country general desk illuminance is 300 lux, and additional 200 lux to 400 lux can be added depending on purpose and need. Same for engineering drawing table, normal illuminance is 500 lux but additional 400 lux to 600 lux can be added depending of the demand. Same as for walking corridors, additional 50 lux can be added to general 75 lux if it is needed.

Evan Mills *et al.*[44] have published his deep research work on 19 different countries in Europe, Asia, and America with the finding that these standard illumination levels are not constant over time, specially parameters like economy or energy crisis directly hit on these standard illumination level. Many countries in Europe redesigned the standard illumination level during oil crisis in 70th decade. For European standards, European Committee for standardization (CEN) is the highest authority for standard illumination collaborating with the International Commission on Illumination (CIE) and Illuminating Engineering Society (IES) of North America. Besides these, some countries have their own national standards. UK Chartered Institution of Building Service Engineers (CIBSE) is the highest authority for illumination standardization. National Research Council Canada (NRCC) is the national standard council for Canada different than any

other country makes the standards more related to energy savings.[45].

During my work, the indoor measurements have been considered as a mock official working desk. To design the appropriate illumination in a working desk the most important is visual comforts. If the work can be done without any difficulties, the illumination level normally can be called as a good illumination level. Comparing with the main task area, its surrounding areas should be one level lower in illumination. The main task area illumination level and its surrounding illumination level has been defined by the CIE *EN12464-1* standards, values are given in lux bellow, where each of the second value represent the task area illumination, and first value is for surroundings. For example if the task area is 300 lux, the surroundings should be 200 lux for a comfortable working zone.

| |
|--|
| 20–30–50–75–100–150–200–300–500–750–1000–1500–2000–3000–5000 |
|--|

Table 4: The foreground and background illumination level given in lux units. As for example, if the main task area illumination is 500 lux, the surrounded area illumination should be 300 lux for visual comfort.

3.5 Outdoor Light Measurement Method

Unfortunately there is no suitable literature or research work found describing the daylight measurement method at outdoor environment exactly. A general overview has been found after long online research that the outdoor measurement terminal should be shadow or extra reflection free, that means the light coming from the sun and the open sky should be natural and homogeneously received by the measurement device sensor(s). The measurement base should be setup on an uniform surface. The measurement height should be determined depends on the purpose of measurement, for my work standard eye level height 165 cm has been taken as a constant height to continue the measurement regularly [46].

3.6 Open Exterior Area Light Measurement Methods

The indoor light measurement method depends on the four parameters; purpose of the measurement, position of the luminaries, the area that luminaries cover, the optical device(s) that has been used for measurements [47]. Usually the device designed and manufactured with cosine corrected and with proper, either automatic or manually calibration option. The presence of any large obstacles that can block the light path received by the device sensor or any glossy surface or object that can add extra illumination to the sensor should be avoided and the device should be placed on a solid plane ground. According to the sensor position, predetermination of the horizontal and vertical directions or any other required directional measurement is necessary.

As a general understanding of a surface in open exterior area's light measurement, grid measurement technique for horizontal direction gives better results. In grid measurement, the whole area should be divided into even number of grids [48] that can be helpful to determine the mid-points of the whole area, both in height and length. The luminaries position and height plays an important role determining the size of the grids. First for such a place measurement, considering the whole area surface, presence of luminaries and objects are crucial. Usually the grid size should be half of the luminaire's position or 4.58 meters whichever is smaller. For a standard 50 m² surface area can be divided in to 16 sub-areas where the luminaire is in normal height, 2.5 meter from the ground [49]. It is also recommended that each of the sub-areas should be measured minimum 4 times to get the arithmetic average illumination for that particular area. The measurement procedure has been showed for horizontal direction, as for this

kind of place vertical illumination is only being used. The vertical measurements take place from 71 cm to 76 cm above from the ground. For my work, the height for vertical measurement and multi-measurement techniques have been used to minimize measurement error.

3.7 Indoor Light Measurement Methods

For an indoor lighting environment where the electric lights are considered as the main source of illumination, for example an office environment, the light measurement height should be from 71 cm to 76 cm. This height is a standard task plane that is also the standard office desk height [49]. The indoor lighting condition should not be constant over the whole working period. A tunable feature that allow to vary the light at different period of the time with a pace with the daylight change can give a better result on occupants' health. Different spectral power distribution (SPD) of light cause different non-visual effects on occupants' circadian rhythm as most of the day period they stay in an indoor lighting environment. Researchers found that the eye level irradiance and thence their circadian impact are same for D50 and D55 CIE standard illumination on occupants, working in a standard desk illumination level. Normally office lighting environment also can be categorized in two classes:

1. Places sunlight included
2. Places sunlight excluded

Both of the places have some merits and demerits. In direct sunlight included places the illuminance level mainly varies with the sun illuminance that varies during the period of time; for example in morning around 11 am, the illuminance level in a normal altitude can be around 199 lx, at 12 pm, mid-day it can be around 262 lux, and in afternoon around 4 pm the illuminance level can be 107 lx or less [50] when the electric light covers the lack of illumination. Direct sunlight ensures a good color rendering, so the color rendering mainly depends on sunlight [51]. For a direct sunlight excluded place the minimum illuminance level can be from 300 lux to 550 lux , varies with purpose of use, with good color rendering, correlated color temperature, a dimming facility can add extra effort as occupant can control the illumination level as required comparing with the outdoor sunlight condition [52].

For an indoor office environment, detecting average illumination in horizontal direction is most common, except for any special purpose to detect the illumination in vertical direction [53]. The entire measurement area should be divided into equal sized sub-squares, taking the reading at the center of each of the squares and find the arithmetic mean. Using a relatively dense rectangular grid of measurement locations is usually necessary in spaces that are obstructed, lack orthogonal geometry or having highly non-uniform illumination. For spaces with usual room cavity ratios or highly non-uniform illumination, as in the corridors under emergency lighting conditions a denser grid of measurement points may be necessary. For more uniform and symmetric rooms and luminaire positions, a uniform survey method for measuring and reporting the necessary data for interior applications as been developed. The method has been found generally reliable to within an accuracy of 10% [54]. It has the advantage of using weighted average of measurements made at select locations to minimize the number of measurements required. Depending on the area, symmetric properties, number and location of the luminaire, 6 different measurement methods has been standardized by Illumination Engineering Society (IES) committee[54].

1. Regular Area With Symmetrically Spaced Luminaires in Two or More Rows
2. Regular Area With Symmetrically Located Single Luminaire
3. Regular Area With Single Row and Individual Luminaires
4. Regular Area With Two or More Continuous Rows of Luminaires

5. Regular Area With Single Row of Continuous Luminaires
6. Regular Area With Uniform Indirect Lighting

3.8 Regular Area with Symmetrically Located Single Luminaire

From the above six types of indoor light measurement, for my experiment purpose only the “area with symmetrically located single luminaire” has been applied as our measurement surface is almost square shape and the developed single LEDs panel is located at the center of the square shaped surface. This kind of lighting may also available in general working area, seminar or conference hall. The measurement terminals should place over the plane surface and standard horizontal level 71 cm to 76 cm. The measurement terminals are classified in three types, inner bay is at the middle of the measurement area, half bay is are two end sides of the measurement area, minimum 60 cm away from the wall, and the quarter bay is the two corner side measurement of the area.

The single luminaire is often bright enough, and the light scattered from the source is being homogeneous by using good diffuser, reflector or lens(es) to scatter the light in all direction properly. The indoor light measurement method also applied over a working desk to determine the average illumination and later in our light booth average illumination determination this method has been applied (fig.22). The more details about the measurement has been described in section 4.7. The average arithmetic illumination, \bar{E} in this square homogeneous area can be determined from,

$$\bar{E} = P$$

Where,

P = average of measurements at stations p-1, p-2, p-3, and p-4 in all four quarter bays (fig.5).

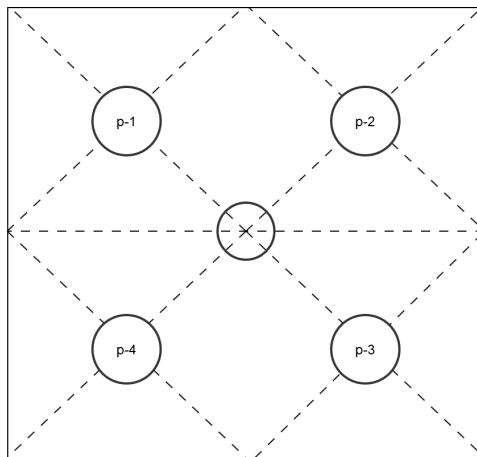

Figure 5: Regular area with symmetrically located single luminaire measurement terminals. The square solid line represents the area where the luminaire position is at the middle of the circle. $p1$, $p2$, $p3$, $p4$ are the measurement terminals

4 Experiments, Results and Discussions

The main discussions of this chapter are the light measurements in three specific locations—outdoor, open exterior area and indoor with constant setup with Konica Minolta Spectrophotometer CL-500A. Later further analysis of the recorded data from outdoor and open exterior area have been elaborated as a mathematical average for each of the month separately with two different particular time 12 pm and 4 pm to compare the irradiance changing pattern between four different months. Then a short description of the light booth set up, the measurement methods, positions of the optical devices and luminaire that has been used, illumination level and color rendering properties of the LED panels have been illustrated. As a pre-designing work of the LED panels, the LED packages have been tested compared with the manufacturer provided configuration and classified them correctly for further development of the LED panels. Five different LED panels have been designed applying different LED matrix pattern and irradiance mapping to compare best light outcomes. The irradiance values of the panels could be controlled by the mapping techniques for each of the single LED package separately using a graphical user interface (GUI) developed with MATLAB either automatically or manually. Finally light properties have been measured and compared with the standard property values for finding the compatibility of the designed LED panels.

4.1 Daylight Irradiance Data Acquisition

Finland is among those other Nordic countries located in the extreme north hemisphere in the Arctic Circle. The geographical coordinates of Finland are, latitude 64°N , and longitude 26°E [55]. Due to this extreme geographical location the sun beam reaches the surface varies a lot from season to season. Like other countries in Europe, Finland also has four seasons where the daylight conditions have extreme difference from one season to another. According to the data of *Finnish Meteorological Institute*, winter starts around November, spring around early April, summer in late May and autumn in the last week of August. This time period is not constant, and it may vary more or less every year.

Designing a green building in this region utilizing the daylight in most efficient way, knowing the daylight changing pattern in each of the season is very important. During summer the sun rises almost always above the horizon level and during winter it rises almost always below the horizon level, made it more difficult to design green buildings in these region and that is why knowing the daylight changing pattern is most significant.

In that purpose of knowing the daylight changing pattern, daylight data has been recorded over the months of February to May, that gives use overall a nice view of daylight change from season winter to spring in this region. For the regular irradiance data record, two particular locations have been carefully selected considering the daylight availability, shadow and glossy effects and other environmental conditions like ground homogeneity. The measurements have been continuously carried out for a four months period of time, February to May, 2015. Three days in a week have been selected- Monday, Tuesday and Friday and two times per day, during mid-noon at 12 pm and during afternoon at 4 pm. The measurements have been taken 10 minutes in each of the locations. The sky condition was extremely variable from month to month, even in the single month or day. According to the three categories of sky determined by Illuminating Engineering Society of North America (IES), during daylight data acquisition the sky condition was cloudy, overcast and clear sky. Weather condition was also extremely variable like heavy, medium and light snowfall, rain, strong wind, and a combination of rain and strong wind.

These extreme weathers might have mild impact on the data acquisition.

4.2 Measurement Optical Devices

Three optical measurement devices have been used for outdoor, open exterior and indoor light measurements, LED packages testing and classification, and designed LED panels quality testing. The first device is *Gigahertz-Optik-BTS256-LED Tester*6, used for luminous flux, spectral data for small sized assembled and non-assembled LED packages in visible spectrum. According to the Gigahertz Optik BTS256 user manual, the device is able to do optical measurement in the visible range of 380 nm - 755 nm. The built in 10 mm input diameter conical type adapter placed over the non-assembled LED packages to test their peak wavelength and luminous flux. The second device is *Konica Minolta Illuminance Spectrophotometer CL-500A*, used to record daylight spectral irradiance data in the range of 360 nm-780 nm with chromaticity coordinates, correlated color temperature (CCT), color difference, d_{uv} from black body locus, E_v , and dominant wavelength. Zero calibration is required every time after the device turned on. The spectral templates along with the device installation software have been used for data transform from the device. The third device is *Konica Minolta Chromameter CL-200*, used to measure the illuminance level directly at horizon level to find the average illuminance of the designed LED panels.



Figure 6: Measurement devices, (a) Gigahertz-Optik-BTS256-LED Tester (b) Konica Minolta Illuminance Spectrophotometer CL-500A, (c) Konical Minolta Chromameter CL-200

For outdoor daylight measurements, five different directional points, one in vertical direction and four others in south, west, north and east horizontal directions (clockwise) have been measured. For open exterior area four horizontal directions, south, west, north and east (clockwise) have been measured with Konica Minolta Spectrophotometer CL-500A. Compare with the standard eye position on a plane surface, the vertical (\vec{E}_z) and horizontal (\vec{E}_h) directions are showed in fig.7 bellow.

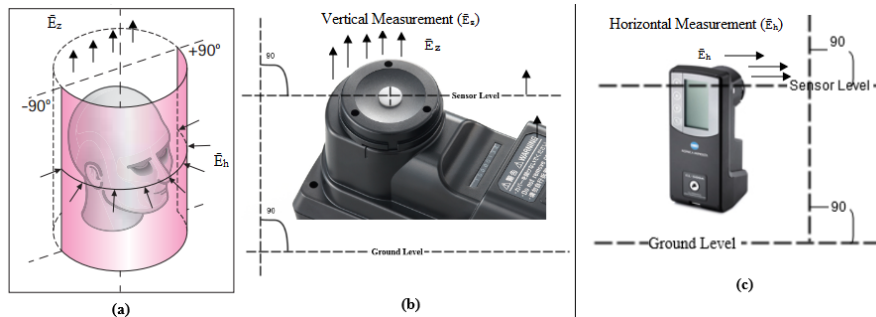

Figure 7: (a) the vertical and horizontal measurement directions w.r.t. the eye position, (b)the vertical measurement direction w.r.t. the sensor position, (c)the horizontal measurement direction w.r.t. the sensor position

4.3 Outdoor Daylight Irradiance Data Acquisition

The outdoor location is situated in Arena Parking Lot, Joensuu, Finland with geographical coordinates, latitude $62^{\circ}36'N$, longitude $29^{\circ}44'E$ far from nearby buildings or other large glossy obstacles that could add extra illumination effect to the exact natural daylight illumination. The location is also far from trees or any large objects that could create shadow effects (fig.8) in data acquisition. The direct sun and diffused sky are considered as the only sources of illumination in that outdoor location daylight measurement. If the daylight received by the vertical or horizontal planes, it can also be calculated together with the light reflected from the nearby noticeable large objects and the ground. Mathematically the polluted irradiance detected by the device sensor can be expressed as [3]:

$$E_z = E_d + E_{rb} + E_{rg}$$

Where,

E_d = The daylight directly coming from sun and sky and reaching the vertical surface

E_{rb} = The daylight reflected from buildings and other obstacles and reaching the vertical surface

E_{rg} = The reflected daylight from the ground and reaching the vertical surface.

In outdoor measurement terminal, the value of E_{rb} and E_{rg} have been kept in minimum (assumed the both values are 0) in my measurement that could make the data acquisition noisy. The measurement device has been set up on a flat surface with a fixed height using a monopod that is 165 cm from ground. Because of the snow covered the ground during winter with a thickness of 10 cm, during spring the height of the monopod has been adjusted according to that level to continue the consistency of height. The surrounding ground was also uniform for a large extension. One vertical directional and four horizontal directional measurements in south, west, north and east (clockwise) irradiance directly by the sun have been recorded intensively.

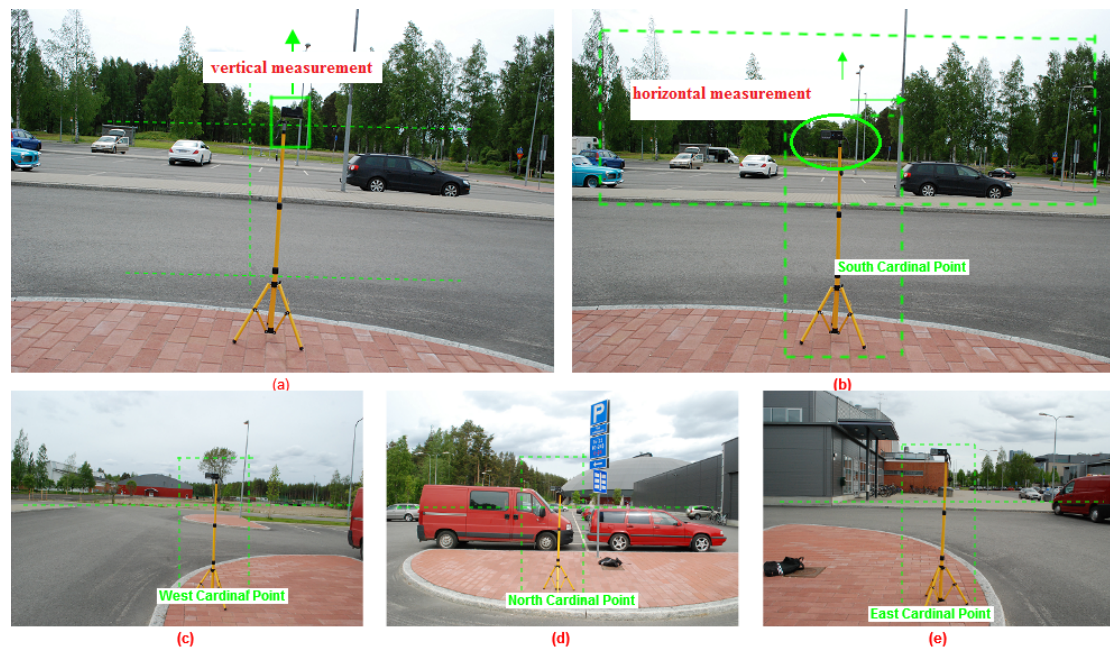

Figure 8: Outdoor daylight measurement location; (a) the vertical measurement according to the device sensor position (b) the horizontal measurement in south cardinal point (c) the horizontal measurement in west cardinal point (d) the horizontal measurement in north cardinal point (e) the horizontal measurement in east cardinal point; the height has been selected according to the eye position

4.4 Outdoor Daylight Irradiance Data Analysis

The mathematical average irradiance change for each of the four months has been illustrated for vertical direction in fig.9, and for four different horizontal directions in fig.10–13. The solid blue, green, yellow and red lines represent the average irradiance at 12 pm for February, March, April and May respectively. The broken blue, green, yellow and red lines represent the irradiance at 4 pm, February, March, April and May respectively. In open exterior area irradiance data analysis, described in the next section 4.5 with same color pattern that has been used to visualize the change.

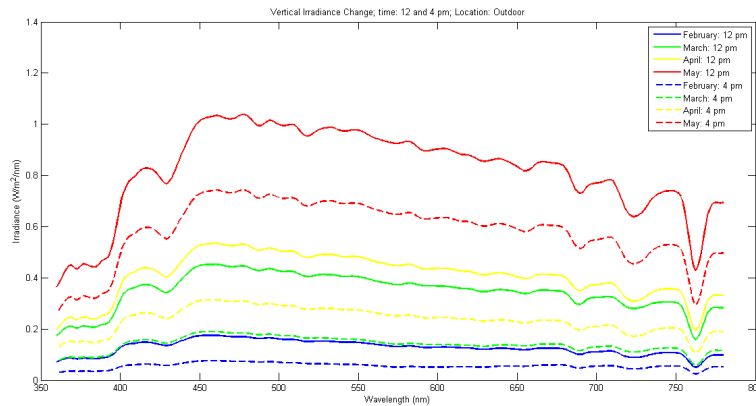

Figure 9: Vertical irradiance change over four months period of time; blue, green, yellow and red solid lines are for February, March, April and May respectively at 12 pm. Blue, green, yellow and red broken lines are for February, March, April, and May respectively at 4 pm

From the average vertical irradiance change, fig.9, it is easily noticeable that the vertical irradiance change is uniform and it has been gradually increased over time. The solid lines indicate the irradiance change in mid-day at 12 pm is higher than the irradiance values in the afternoon at 4 pm with the broken lines. This also represents the end of winter (February, March) to the beginning of spring (April, May). In May, the irradiance has been dramatically increased because of the availability of sunlight. As the vertical directional measurement is effect free from any other environmental factors, the irradiance change is only depends on the solar altitude during these months. During March and April the sky condition was cloudy or partially cloudy and high harshness of the atmosphere has a deep impact on the irradiance values.

The horizontal irradiance values are normally very different in different orientation. During a clear day, owing to the absence of clouds the sky luminance distribution is homogeneous [56] differently in each of the directions separately. During an overcast or cloudy day due to the absence of direct sun at the four horizontal directions, it is almost equally homogeneous although there is still a big variation [57]. This vertical direction is totally depending on the daylight directly receives by the sensor when the four other horizontal measurement, in February, March and April, different thickness of snow was available on the ground, affected by the reflected lights from the white snow.

The four horizontal measurements have been taken in north, south, east, and west directions. The north cardinal point receives quite low irradiance because of the sun altitude at that position. The irradiance change took place irregularly and there are some overlapping between April and May at 12 pm, although at 4 pm the irradiance has increased gradually. The south cardinal point receives the highest irradiance because of direct sun altitude. The irradiance change took place with irregular pattern, especially during the month of March and April. Figure 11 shows that the March irradiance was higher than the irradiance in April, it may happen because a thick snow was available in March with high reflectance rate and both months had lack of direct

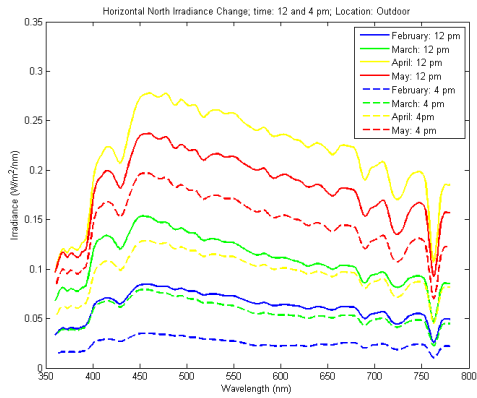

Figure 10: North directional irradiance change

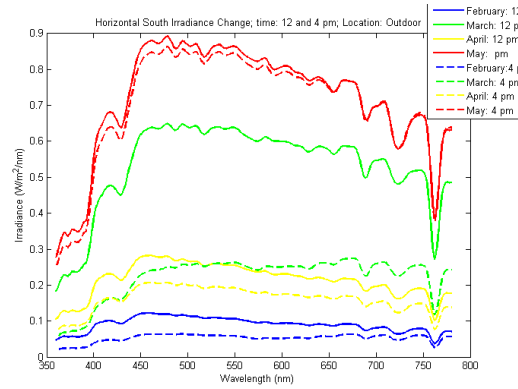

Figure 11: South directional irradiance change

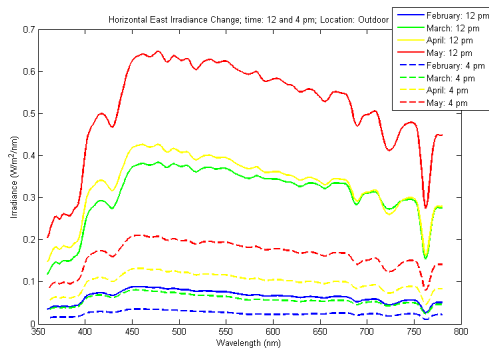

Figure 12: East directional irradiance change

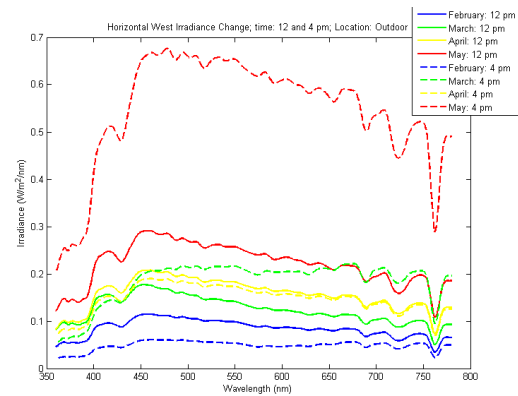

Figure 13: West directional irradiance change

Figure 14: Horizontal irradiance change over four months period of time in four cardinal directions: north, south, east, and west in outdoor location. The blue, green, yellow and red solid lines are for February, March, April, and May respectively at 12 pm, blue, green, yellow and red broken lines are for February, March, April, and May respectively at 4 pm

sunlight. In east and west cardinal points, the irradiance change and irradiance values both are irregular (12, 13). In the east, the irradiance values have increased regular pattern way from 12 pm to 4 pm, when in west, often the 4 pm irradiance is higher than the 12 pm irradiance because the sun in afternoon more in that direction.

4.5 Open Exterior Daylight Irradiance Data Acquisition

The geographical coordinates $62^{\circ}35'N$, $29^{\circ}44'E$ have been selected as an open exterior measurement location. It is the fifth floor from the ground in Network Oasis tower, University of Eastern Finland. The measurements have taken behind a $245\text{cm} \times 177\text{cm}$ with normal transmittance south facade glass window. This fifth floor has been chosen because this height was enough for horizontal level that was not affected by any other nearby buildings' shadows. The measurements have taken 60 cm away from the glass window in north direction. In the west cardinal point of the measurement terminal, there is a normally painted wall with rough reflected surface (4.6, the measurements have carried out enough far distance from the wall that can not affect in daylight data acquisition. The north cardinal point has the presence of compact fluorescent lamps (CFLs). These lamps have definitely large impact on the data acquisition. That north direction is a combination of daylight and electric light, and it has been reflected on the data analysis. Finally in east cardinal point there is an opaque glass window, although it should add some extra irradiance in original irradiance value, but actually it did not add any extra values in data acquisition fig.15 because of the sun altitude at that position at both 12 pm and pm.



Figure 15: Open exterior daylight measurement location; (a) the measurement location is at the fifth floor in Network Oasis tower that is shadow free from nearby buildings (b) according to the position of the south facade window, the south and north horizontal measurement directions (c) the west cardinal horizontal measurement direction (d) the east cardinal horizontal measurement direction

4.6 Open Exterior Daylight Irradiance Data Analysis

In fig.16 and fig.17 the north and south irradiance changes at horizontal level have been illustrated side by side. The blue, green, yellow and red solid lines represent the irradiance change at 12 pm from February to May respectively and broken blue, green, yellow and red lines represent the irradiance change at 4 pm from February to May respectively. The north cardinal point the irradiance change is very irregular especially the reason is the presence of the CFL lamps. The irradiance values are also very low. The spiky spectra prove the presence of fluorescence. In south cardinal point the irradiance change over time is almost regular at 12 pm and 4 pm, there is a big overlap between March and April irradiance values as well (fig.17). A dramatically change occurred in May irradiance value when the afternoon irradiance is higher than mid-noon. The east and west irradiance change is also irregular. At the east direction, the irradiance value

almost increased in a regular pattern except some common overlapping and it shows the March irradiance at 12 pm is higher than any other month¹⁸. For the west cardinal point, the irradiance is higher at 4 pm than 12 pm because of the sun position. At the late winter of February, both at the mid day and afternoon irradiance values are almost same. Same thing happened in the month April but the irradiance has improved a lot in May (19).

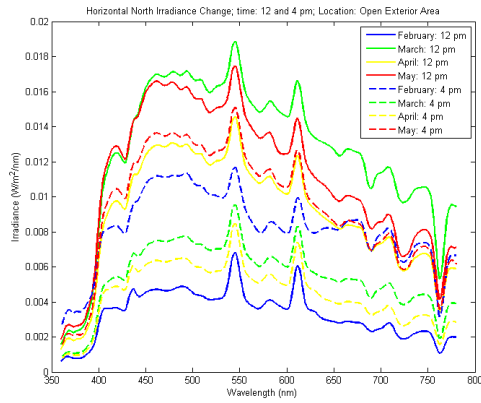

Figure 16: North directional irradiance change

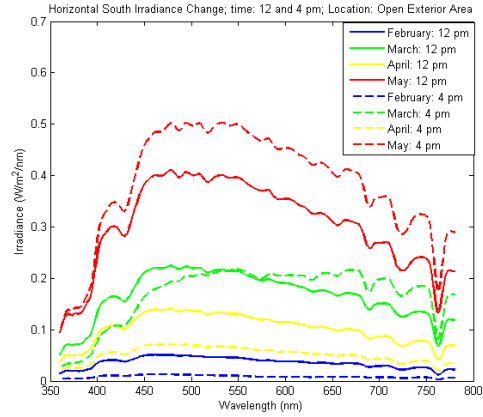

Figure 17: South directional irradiance change

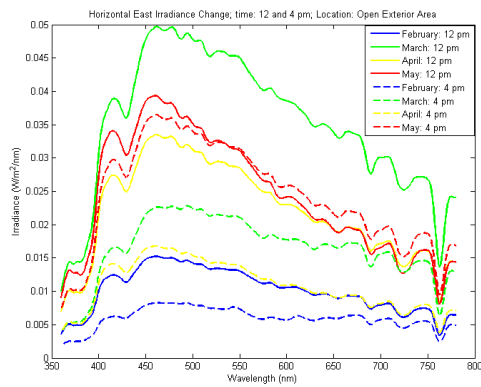

Figure 18: East directional irradiance change

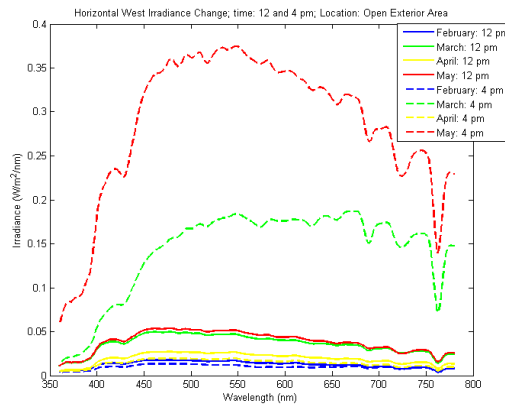

Figure 19: West directional irradiance change

Figure 20: Horizontal irradiance change over four months period of time in four cardinal directions: north, south, east and west in open exterior area location.

At the east cardinal point fig.18 the irradiance value change again very irregular and there are some over laps between the months. Most dramatically irregular pattern at the west facade. Due to the altitude of the sun, the irradiance value has a big change in the late spring, May at 4 pm (fig.19).

4.7 Light Booth Setup for LED Panel Testing

As mentioned in the section 3.8, in the case of a regular area with symmetrically located single luminaire, our light booth is almost square in shape and the LED panels have been hung at the middle of the square surface. So for measuring the average illuminance level in horizontal direction, $\bar{E}_h = P$, this special measurement method has been used. For installing any new luminaire, or to check the performance of an existing luminaire in lab, usually a mock set up or a light booth are being used to find the quality at different points before it applied in real world. Several different positions are being marked for taking the measurements depending on position and purpose of the luminaire. To design such a setup for measuring the illuminance level, grid

measurement techniques are normally used. The size of the grids are 60 cm each, more or less according to the total area the light covers.

In order to test of the quality of designed LED panels, our light booth has been set up. The light booth (fig.21) is 117 cm in length and 115 cm in width, table surface is painted with matte grey color and the whole booth is covered with thick black curtain to stop the ambient room light and minimize interior reflectance. From bottom to the top, the light booth is 188 cm in height and the table surface from ground is 71 cm, standard office desk height. The LED panel has been hung at the middle of the light booth through an adjustable holder that can move maximum 90° angle in each direction from the main axis. The LED panel is 33 cm in height, a diffuser has been installed 4 cm distance from the top of the LED panel. With the diffuser the height of the panel is 37 cm. From the bottom of the LED panel to the top of the table surface is 80 cm with diffuser and 84 without the diffuser.

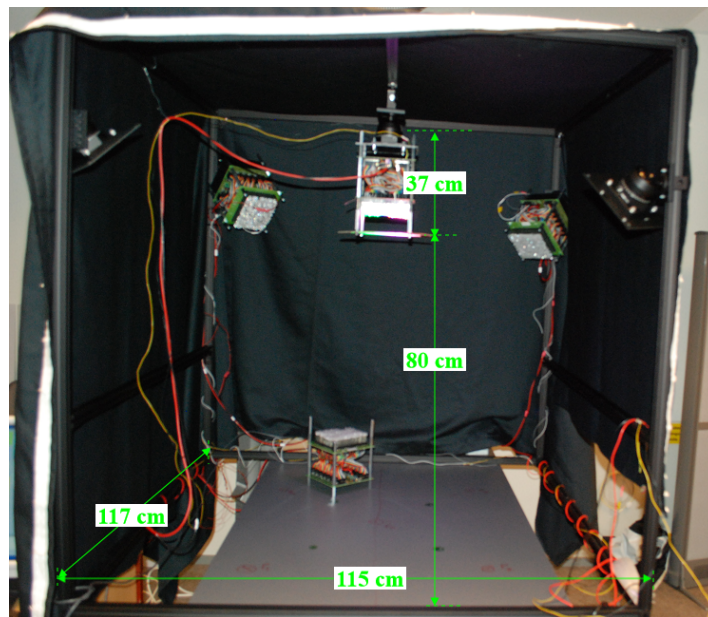

Figure 21: The light booth setup according to the LED panel position

The table surface has been marked for measuring the vertical illumination level at different points. Two totally different average illumination at horizon level \bar{E}_h have been measured for determining the average illumination for the LED panel by Illuminating Engineering Society (IES) of North America average illumination techniques [58] and true average illumination techniques [59].

In IES average illumination measurement 22 method, sufficient illumination points have been measured and then find out the average illumination. Here p_0 is the position directly under the LED panel and p_1, p_2, p_3, p_4 are the different measurement terminals located 24 cm far from the center p_0 . J.R Cravath *et al.* has proposed a new average illumination measurement method in his novel conference paper present at CIE [59]. According to his average illumination method, multiply the illumination with the area the luminaire covers and then find the average of it; this method is called weighted mean techniques 23.

In his method, for example there are some circled areas from the center of the luminaire, according to different illumination level in each of the circles. For more than one luminaire geometrical diagrams can be used to find out the area the luminaire covers. Now for A the

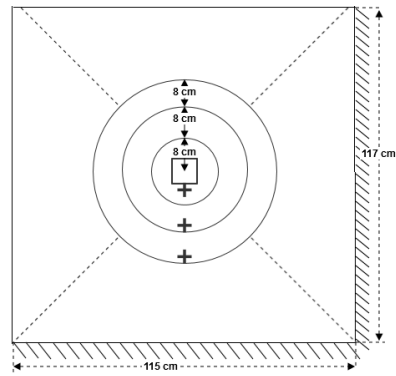
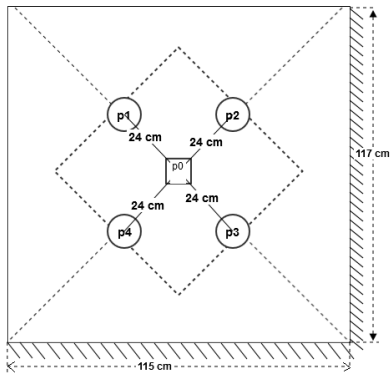

Figure 22: IES average illumination measurement method Figure 23: True average illumination measurement method

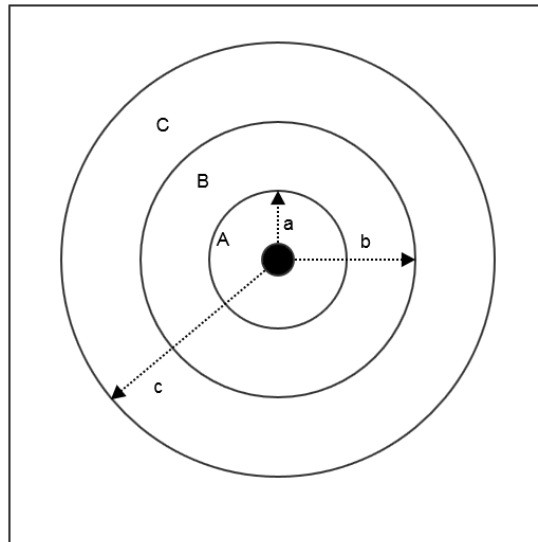

Figure 24: True average illumination level measurement technique

diameter is a , B is b and C is c (fig.24), then the true average illumination will be,

$$I_{\text{avg}} = \frac{\frac{\pi}{4}[a^2 \times \text{illumination of } A + (b^2 - a^2) \times \text{illumination of } B + (c^2 - b^2) \times \text{illumination of } C]}{\frac{\pi}{4}c^2}$$

4.8 Basic Structure of LED Package

For daily use purposes, different kind of luminaries with different styles and shapes are available in the market. Each and every luminaries have their own applications, for example wall wash, wall graze, spot light, flood light, stage light, cove light, general light fixture, direct view light. The luminous efficiency of LED lamps is higher than any other traditional lights. For example, for a standard 1600 lumen generation where incandescent lamp requires 100 Watts, halogen incandescent lamp requires 77 Watts, compact fluorescent lamp requires 23 Watts, the LED lamp requires only 20 Watts [60]. This makes the LED lamp better than any other light sources. Also the color rendering properties, the longevity and safety of LED lamp is higher than other lights. Although still nowadays compact fluorescent lamp is a hard competitor, but LED is taking place over it.

LED manufactured as packages where each of the packages contain one or more LED dies with wire bonded connections, optical elements, mechanical, electrical and thermal interfaces [61]. The LED chip is a crystal wafer that has been manufactured following the ANSI standards to ensure of high level on chemical purity [61]. Commercially in an LED package, the dice is mounted on a base and connected with wires. The whole system is encapsulated with an epoxy resin that gives the highest flux efficiency [62]. Heat sink is installed when the LED package is incorporated in LED luminaries. In the wafer of the semiconductor, the p type diode is taken over an n type diode for the designing of p-n junction in the package (25) [63].

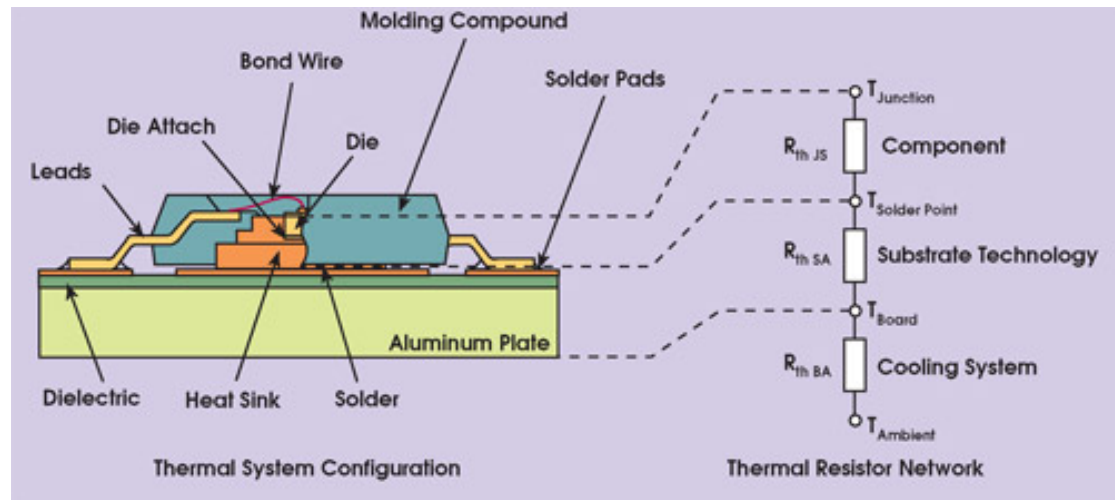

Figure 25: The cross section of a LED package shows a typical high-brightness 1 Watt LED and its associated thermal system configuration [64]

According to the position of the emission of light from the LED package, it can be categorized into three different classes [64].

1. Surface emitter LED
2. Edge emitting LED
3. Super luminescence LED

The most general use of LED package for commercial purpose is to generate white light. The correlated color temperature (CCT) of such white light is generally used 2700K (warm white),

3500k (neutral white) and 6500K (cool white) [65]. There are many ways to generate white light using different kind of LEDs. Each of the methods has their own advantages and disadvantages. Some widely used methods are [62]:

1. Convert a short wavelength (blue wavelength) optical radiation with a down conversation yellow phosphorous to create a broad emitting SPD.
2. Combine multiple narrow band LEDs using additive color mixing (RGB).
3. UV LED with RGB Phosphor where the UV light is used on phosphor to generate red, green and blue light and later mix together to generate white.

Although LED has more advantages over traditional light sources, but still it has some serious drawbacks. Some major disadvantages can be heat management, flicker and glare problems. Another big problem for electroluminescence like LED is the shift of the wavelength according to the heat emitted from the packages. As LED light has a long life time, this problem may create a noticeable difference in light output, correlated color temperature (CCT) and color rendering index [66]. For example, *AlGaN* is used to produce high intensity green light, but due to the temperature increase, more and more green wave move to the red wave known as red shift and if the temperature is being decreased, the opposite incident happens called blue shift. There is a close relation between energy gap, E_g , peak wavelength λ and the emitted temperature T . The relation can be described as follows [66],

$$E_g \propto \frac{1}{\lambda}$$

Where,

E_g = Energy gap

λ = Dominant wavelength

On the other hand, the relation between energy gap and increasing temperature is [66],

$$E_g \propto \frac{1}{T}$$

So together it can be said that $\lambda \propto T$; the more and more the temperature increases, the more and more the peak wavelength shifts to the larger wavelength called red shift.

4.9 Pre-LED Panels Designing Work

Before designing the LED panel, all the available LED packages in lab have been tested to find their peak wavelength and irradiance values using Gigahertz-Optik-BTS-256 LED Tester and Konica Minolta CL-500A Spectrophotometer. Two temporary setup have been designed with the devices to boost the measurement system.

It has been found that often the manufacturer given data are not equal to the tested data, for example the peak wave length often found $\pm 10\text{nm}$ different than the actual manufacturer given wavelength as well as the same result also found for the irradiance value. All the LED packages are tested and labeled according to their right peak wavelength for future research as well. Total 32 LED packages are available with label, only one package that has been found without label, it is very hard to categorized it with spectral data and physical appearance. In table 5 the 32 different LED packages data has been showed along with tested E_v values, chromaticity coordinates (x,y), and peak wavelengths. Only the brightest LED packages with higher irradiance values are being selected to perform further test with different LED panels, in that way 13 brightest LED packages have been selected.

The spectrum of all 32 LED packages have been illustrated in fig.26. From the figure it is noticeable that among 32 LED packages, most of the LED packages are with low irradiance values, only 13 LED packages have been found with high irradiance that have been used for designing 13 LED circular matrix panel described details described in section 4.14.

| Manufacture Number | E_v | x | y | Peak Wavelength (nm) |
|----------------------|-------|--------|--------|----------------------|
| HLMP-EG2BXY0DD | 14.4 | 0.6952 | 0.3045 | 631 |
| L-53MBC | 0.1 | 0.1541 | 0.0425 | 425 |
| HLMP-CB3A-UV0DD | 6.7 | 0.1302 | 0.0670 | 466 |
| L5-G81N-GUV | 32.5 | 0.1946 | 0.7243 | 525 |
| HLMP-3950 | 0.7 | 0.4491 | 0.5482 | 566 |
| L5-N52N-FTU | 11.9 | 0.4331 | 0.3896 | 592 |
| L-53MBTL | 0.1 | 0.1530 | 0.0371 | 427 |
| L-53VGC | 18.2 | 0.1511 | 0.7174 | 518 |
| HB5D-4333EBA-D | 6.6 | 0.0708 | 0.4676 | 497 |
| OSM54L5111P | 25.5 | 0.4255 | 0.4053 | 629 |
| HLMP-EL15-UX000 | 8.1 | 0.5677 | 0.4316 | 591 |
| OSV6YL5111A | 0.1 | 0.1706 | 0.0076 | 410 |
| L-53SRC-F | 3.2 | 0.7189 | 0.2811 | 654 |
| L-7113SYC | 7.3 | 0.5971 | 0.4023 | 596 |
| 333-2SDRC/H0/S400/A6 | 1.5 | 0.7174 | 0.2824 | 655 |
| L/7113ZGC | 26.6 | 0.1443 | 0.7221 | 517 |
| L-53SEC | 4.8 | 0.6610 | 0.3387 | 614 |
| WW05A3SB04-N | 11.3 | 0.1380 | 0.0493 | 461 |
| LL-504BGC2E-G3-1BC | 36.8 | 0.0692 | 0.5698 | 501 |
| 1224UYOC/S530-A6 | 0.4 | 0.6563 | 0.3434 | 612 |
| LL-503UGC-2E-2BC | 0.7 | 0.4545 | 0.5440 | 571 |
| L-7113HD | 0.0 | 0.6532 | 0.3280 | 710 |
| L-53SYDK | 1.1 | 0.5930 | 0.4064 | 595 |
| WW05A3AYP4-N | 9.1 | 0.5716 | 0.4277 | 592 |
| WW05A3SWT4-N | 32.4 | 0.2886 | 0.2902 | 448 |
| WW05A3SRP4-N | 18.9 | 0.6926 | 0.3072 | 631 |
| HLMP-EL3B-WXKDD | 9.4 | 0.5800 | 0.4194 | 594 |
| 383-2UBGC | 9.5 | 0.0909 | 0.6278 | 506 |
| 1224USOC/S530-A6 | 0.6 | 0.6796 | 0.3198 | 624 |
| L-7113SRC-E | 2.3 | 0.7146 | 0.2848 | 649 |
| 383UBC/H2 | 0.1 | 0.1537 | 0.0371 | 427 |
| NO LABEL | 3.2 | 0.7186 | 0.2814 | 653 |

Table 5: Peak wavelengths for all 32 tested LED packages

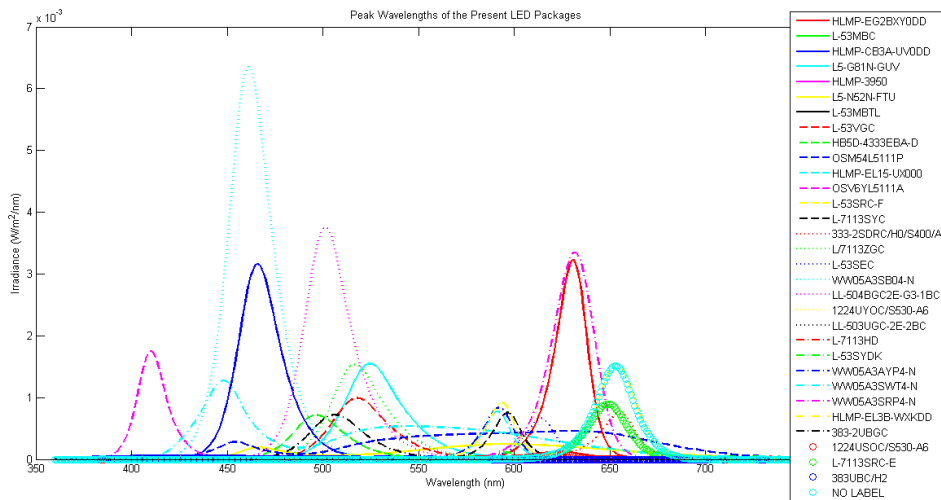

Figure 26: Irradiance values of 32 LED Packages

4.10 Designing LED Panels

Two separate breadboards have been designed with four different matrix pattern, and five different irradiance mapping with 5 voltage power source each of the panels. Each of the breadboard consisted with 252 LED package holders. Additive color mixing and opponent process color theorem [67] have been used for designing the panels and to generate usable white light. First LED panel has been used for three different matrix pattern [68] with red, green, blue and amber LED packages and the second LED panel has been used for using 13 brightest irradiance LED packages [69]. The irradiance values of each of the LED packages can be mapped with a graphical user interface (GUI) developed with MATLAB programming.

A commercial LED luminaire design follows 6 steps respectively [70]:

1. **Define lighting requirements** : the primary purposes should be based either on an existing fixture's performance or on the application's lighting requirements.
2. **Define design goals** : before starting the designing process, the goals should be determined, which will be based on the application's lighting requirements.
3. **Estimate efficiency of the optical, thermal & electrical systems** : for a real world application of the luminaires, optical, thermal and electrical systems are important. Good estimations of efficiency of each system can be made based on these constraints. The combination of lighting goals and system efficiency will drive the number of LEDs needed in the luminaire.
4. **calculate the number of LEDs required** : based on the design goals and probable estimated losses, it can be calculate the number of LED packages needed to meet the design.
5. **Consider all design possibilities and choose the best** : as with any design, there are many different ways to best achieve the design goals. LED lighting is still a new field, so assumptions that work for conventional lighting sources may not apply to LED lighting design.
6. **Complete final steps** : complete circuit board layout. Test design choices by building a prototype luminaire. Make sure the design achieves all the design goals. Use the prototype design to further refine the luminaire design. Record observations and ideas for improvement.

In our LED panel designing these six steps have been followed according to the right sequence to get the best outcome from different designed panels.

4.11 RGBA Column Matrix Pattern LED Panel

Total 224 LED packages have been used in a 14×16 LED matrix panel with each of the LED packages in four rows each, total LEDs of each of the type are 14×4 , 56. The equal number of LEDs have been used for obtaining the optimized curve provided by Monash University, Malaysia. The target spectral curve has been normalized and optimized according to the irradiance to gain the highest circadian action factor (CAF). For this panel and next two other RGBA panels with different LED packages matrix pattern (subsection 4.12 and 4.13), the circadian action factor (CAF) is in the range of 0.773-1.135 with the melanopic lux 231.796-340.589 range.

| Manufacture Number | Color of the Package | Peak Wavelength (nm) | Total Number Used |
|--------------------|----------------------|----------------------|-------------------|
| WW05A3SRP4-N | Red | 625 | 54 |
| HLMP-EL15VX000 | Amber | 601 | 54 |
| L-53VGC | Green | 520 | 54 |
| WW05A35BQ4-N | 458 | 458 | 54 |

Table 6: RGBA column matrix pattern, the LED packages that have been used with manufacture number, color of the package, dominant wavelength and total number those have been used.

The illustrations of the column matrix pattern LED panel have been showed in fig.27 bellow

where each color represents each LED package with the peak wavelength.

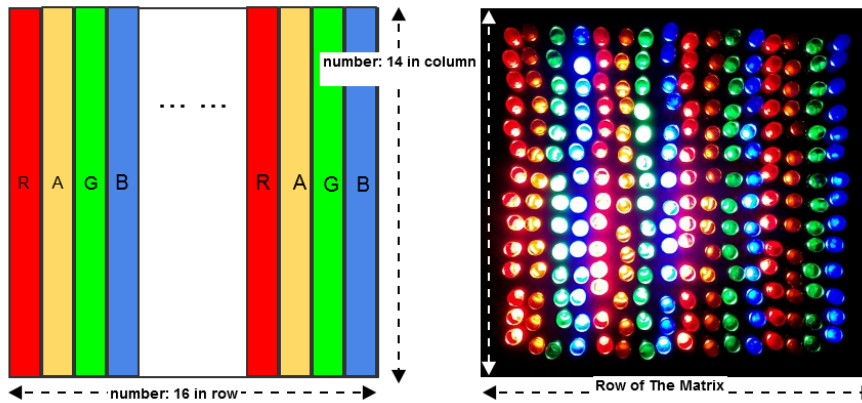

Figure: RGB Column Matrix Pattern

Figure 27: RGB column matrix pattern LED panel designing visualization.

The target spectrum (blue solid line) and obtained spectrum (green solid line) are given below. There is a big difference between the target spectrum and gained spectrum as different kind of LED packages and system have been used. For better illustration, the gained spectrum has been magnified 5x times by irradiance mapping to match with the target spectrum next LED matrix pattern has been tested described in section 4.12 and 4.13.

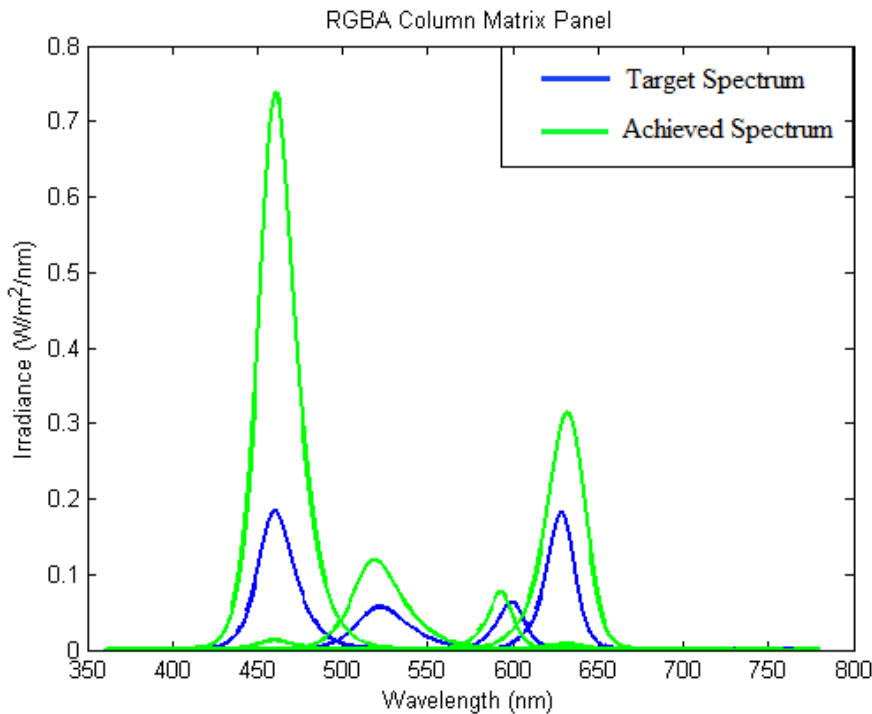

Figure 28: RGB column matrix pattern LED panel spectrum, blue and green line is target spectrum and gain spectrum respectively.

4.12 RGB Circular Matrix Pattern LED Panel

The second LED panel that has been developed with a circular arrangement with the previously used LED packages. In previous gained spectrum there was a big difference between target spec-

trum and gained spectrum. With the possible irradiance value mapping with GUI, it was not still possible to round up the irradiance of 4 different LED packages. It has been found that the difference between red and blue is really huge. Moreover as in previous LED panel, the Amber irradiance is very low, in this panel new amber (HLMP-EL3B-WXKDD) LED packages have been used which have the same peak wavelength as first type amber (WW05A3AYP4-N) but with brighter irradiance value. Total 252 LED packages have been used with the same number, 63 of each. The irradiance value also controlled with the GUI in each of the triangle of the same LED packages according to the target spectrum.

| Manufacture Number | Color of the Package | Peak Wavelength (nm) | Total Number Used |
|--------------------|----------------------|----------------------|-------------------|
| L-53SRC-F | Red | 625 | 63 |
| HLMP-EL3B-WXKDD | Amber1 | 601 | 51 |
| WW05A3AYP4-N | Amber2 | 601 | 12 |
| L5-G81N-GUV | Green | 520 | 63 |
| HLMP-CB3A-UVODD | Blue | 458 | 63 |

Table 7: RGBA circular matrix pattern LED panel design, used LED packages with manufacture number, color, dominant wavelength and total number that have been used.

In this panel design, opponent process color theory has been applied in each of the triangle (fig.30 as red-green, blue-amber stay at the opposite direction. In this panel as we do not have any yellow, in spite of that color, amber has been considered as the opponent of blue as it has close wavelength with yellow. As there are no convex or concave reflector that could point all the different color beam at a homogeneous point surface, the goal and expectation of this pattern is to receive white light at least at the center of the panel. All the LED packages are emitting straight beam, so especially in center the ratios of each of the LED packages have been inserted carefully according to the brightness and irradiance value.

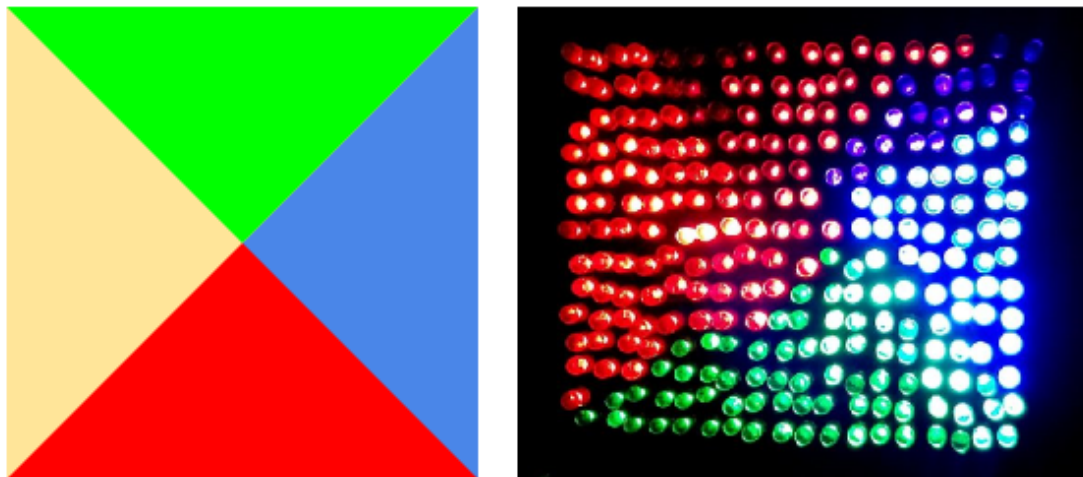

Figure 29: RGBA circular matrix pattern LED panel, red, green, blue and amber color represents relevant LED packages respectively.

In the irradiance distribution curve, the blue solid lines represent the target spectra; green solid line represents the obtained spectra. From this panel a plastic diffuser has been installed 4 cm far from the top of the LED package to get more homogeneous light in the surface, in fig.30 the red solid line is the spectrum with diffuser that decreases peak of each of the LED packages, especially more scattering happened in the red-amber region because of Rayleigh scattering effect,

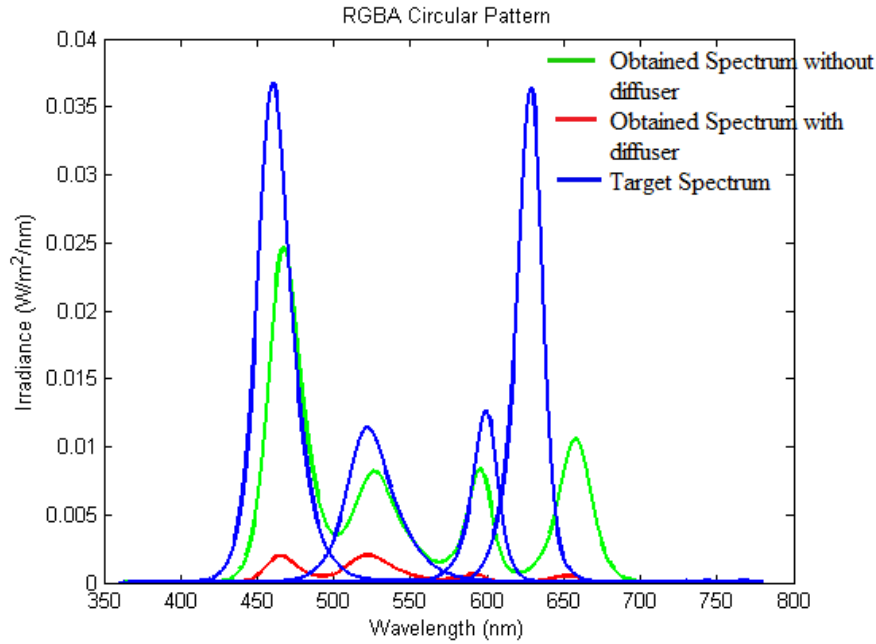

Figure 30: RGBa circular matrix pattern LED panel spectrum, blue solid line is the target spectrum, green and red line are the gain spectrum without and with diffuser respectively.

4.13 RGBa Randomized Circular Matrix Pattern Panel

Although the brightest irradiance of amber and red LED packages have been used in previous LED panel, but still the difference between blue peak and amber-red peak is not same with the target spectrum. In this third LED panel with RGBa LED packages, the number of blue LED packages have been decreased and number of amber LED packages have been increased. This has been done as the irradiance mapping with GUI. As this still could not simplify the peak wavelength between different dominant peaks. The ratio of blue and amber has been used 1 : 3 and the position of the blue and amber packages have been randomized also. Total 100 pieces of amber LED packages and 32 pieces blue packages have been installed in the LED breadboard. According to the ratio of each of the peaks, the red and green LED packages also re-designed.

| Manufacture Number | Color of the Package | Peak Wavelength (nm) | Total Number Used |
|--------------------|----------------------|----------------------|-------------------|
| L-53SRC-F | Red | 625 | 55 |
| HLMP-EL3B-WXKDD | Amber | 601 | 51 |
| WW05A3AYP4-N | Amber | 601 | 49 |
| L5-G81N-GUV | Green | 520 | 65 |
| HLMP-CB3A-UVODD | Blue | 458 | 32 |

Table 8: RGBa randomized circular matrix pattern LED panel designing with the manufacturer number, color, dominant wavelength in nm and number that have been used for each of the packages

Taking the opponent color theory in account, the red-green triangles have been installed in two opposite side to acquire a more white light in the center of the panel.

In fig.32, blue solid line is the target spectrum, and green solid line is the gained spectrum without using the diffuser, there is a big difference and also in the peaks. But after using the diffuser (red solid line) the irradiance almost become equal-irradiance and give the best white light compare with previous two other LED panels.

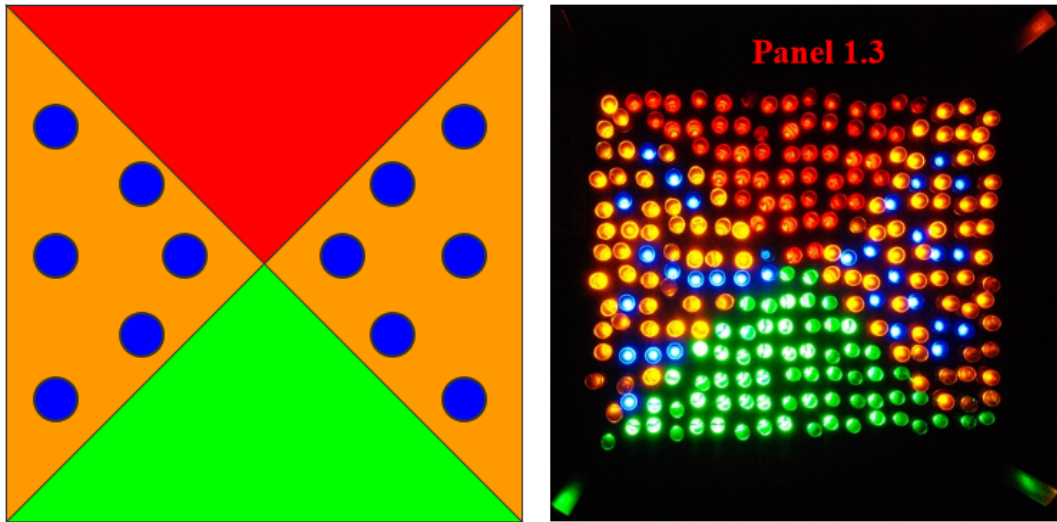

Figure 31: RGB random matrix pattern LED panel, each of the color represents relevant LED packages, blue circle in amber triangle means the randomized position of blue LED package in amber LED package in 1:3 ratio.

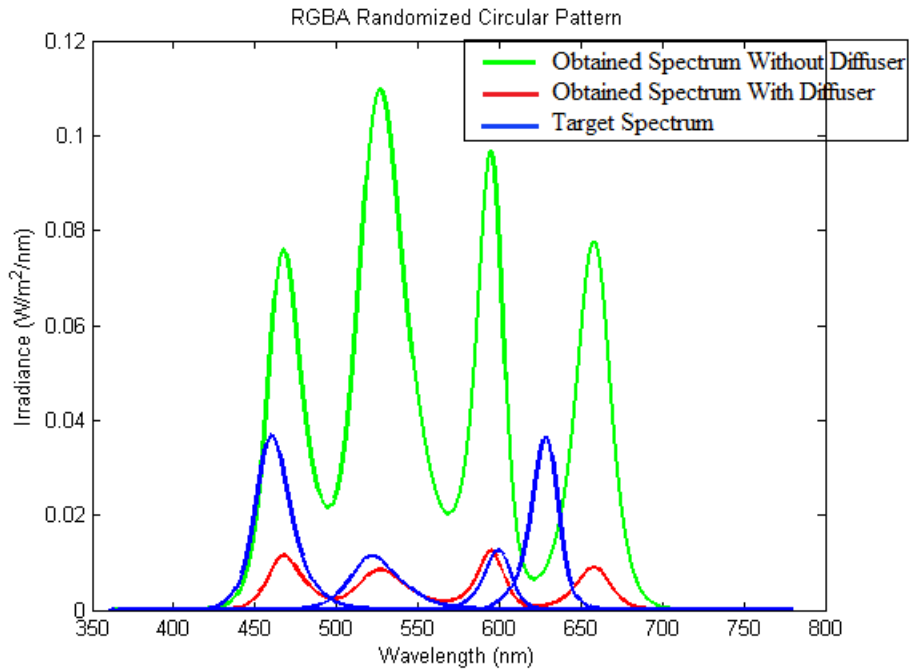

Figure 32: RGB random matrix pattern LED panel spectrum, blue line is the target spectrum, green and red lines are gain spectrum without and with diffuser respectively.

4.14 13 LED Circular Panel for Maximum and Minimum Melanopic Lux

From the previously 32 tested LED packages (fig.5), 13 LED packages with the brightest irradiance value have been separated. Total 252 LED packages have been used with around 13 LED packages of each of the dominant wavelength. In table 9 the total numbers have given for each of the 13 LED packages that have been used for designing this particular LED panel. Each of that irradiance values have been normalized with respect to the highest irradiance value found. The normalized irradiance data then being optimized by Monash University, Malaysia according to highest circadian action factors (CAF) using their developed system.

| Manufacture Number | Package Color | Peak Wave-length | Total Number Used | Max. Mapping Ratio | Min. Mapping Ratio |
|--------------------|---------------|------------------|-------------------|--------------------|--------------------|
| L53SRC-F | Red | 652 | 19 | 20 | 33 |
| L7113SRC-E | Red | 651 | 19 | 5 | 54 |
| HLMPEG2BXYODD | Orange | 631 | 19 | 10 | 79 |
| WW05A3SRP4-N | Orange | 632 | 19 | 84 | 107 |
| WW05A3AYP4N | Amber | 591 | 38 | 120 | 135 |
| HLMP-EL3B-WXKDD | Amber | 594 | 6 | 133 | 105 |
| L5-G81N-GUV | Green | 524 | 19 | 89 | 71 |
| L7113ZGC | Green | 516 | 19 | 18 | 71 |
| L-53VGC | Green | 518 | 6 | 5 | 41 |
| OSV6YL5111A | Purple | 409 | 19 | 41 | 69 |
| WW05A3SBQ4-N | Blue | 460 | 19 | 171 | 163 |
| HLMPCB3AUVODD | Blue | 465 | 19 | 64 | 41 |
| LL504BGCG32BC | Cyan | 501 | 19 | 158 | 71 |

Table 9: 13 LED circular matrix panel designing, the manufacture number has given with the dominant wavelength and dominant color with the LED packages used for each of the class. The irradiance values have been controlled with the GUI developed with MATLAB

The highest circadian action factors have been obtained in a range of 1.012–1.181. Along with the circadian action factors increase the melanopic lux values also increase gradually. Given bellow table.10 the 8 iterations with the 13 LED packages that gives highest circadian action factors in ascending order. Among 8 iterations values, the maximum melanopic–lux 354.447 and minimum melanopic–lux 303.725 have taken for designing the LED panels.

| Number of Iteration | Circadian Action Factor (CAF) | Melanopic–Lux |
|---------------------|-------------------------------|---------------|
| 1 | 1.012 | 303.725 |
| 2 | 1.028 | 308.398 |
| 3 | 1.03 | 309.072 |
| 4 | 1.134 | 340.175 |
| 5 | 1.147 | 344.235 |
| 6 | 1.65 | 349.619 |
| 7 | 1.68 | 350.495 |
| 8 | 1.181 | 354.447 |

Table 10: 13 LED panels' CAF and Melanopic–Lux values for 8 different iteration steps are given here. Among these 8 different iterations, the first row and the last row melanopic lux values which are the highest and lowest values are taken into action for designed LED panel testing

Additive color mixing and opponent process process color theorem again used for design this panel, red-green, blue-amber four zones have been divided with their nearby dominant color wavelength. As the same pattern has been used both for maximum and minimum melanopic–

lux, the irradiance values have been mapped directly by the GUI. Table.9, column 5th and 6th is showing the mapping irradiance values for maximum and minimum melanopic–lux respectively.

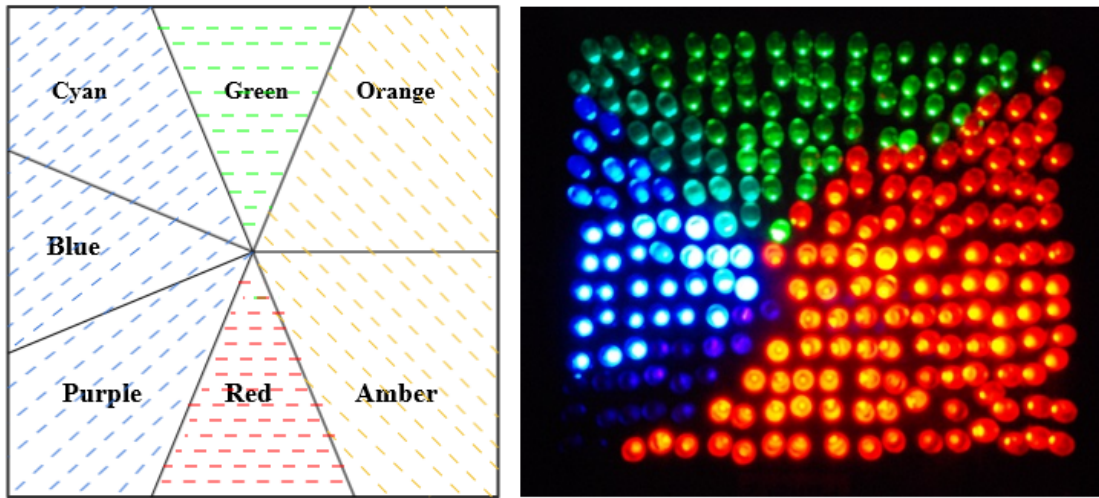

Figure 33: 13 LED circular matrix pattern panel

In fig.34 the spectrum have been illustrated for the maximum melanopic–lux and minimum melanopic–lux. The red solid line represents the spectra without using diffuser and the yellow solid line represents spectra with diffuser. For minimum melanopic–lux green line represents gained spectra without diffuser and blue line represents spectra with diffuser. As for the target spectra, only the CAF and melanopic values have been received, so target spectra could not be illustrated.

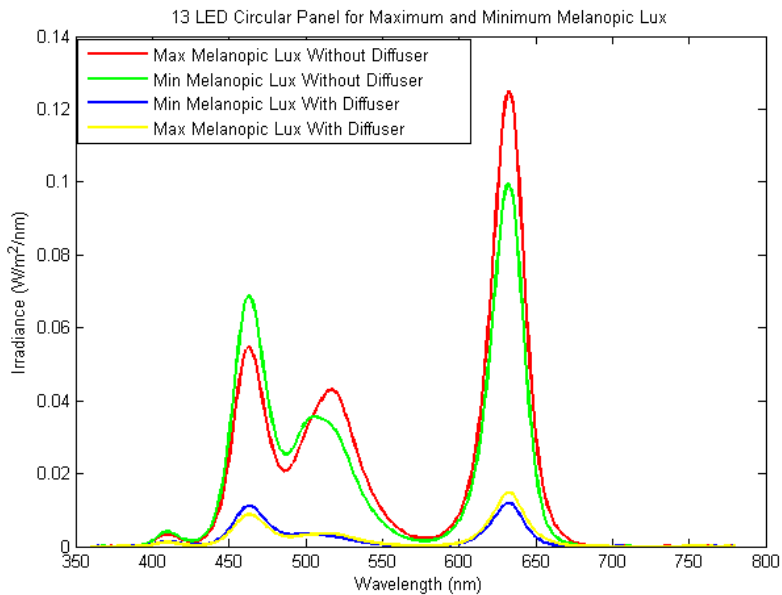

Figure 34: 13 LED circular matrix panel spectrum, the dominant wavelength colors have been given in the left figure. The nearby dominant wavelengths have been kept together after using the opponent color theorem

4.15 LED Panel Quality Testing

The designed LED panels have been tested in the light booth setup. A luminaire testing requires four quality testings according to the European standards (ETAP: EN-12464-1):

1. **Minimum Illumination** (\bar{E}_m): Minimum required average illuminance per task (\bar{E}_m) should be between 300 lx–1000 lx, depending on the purpose. European Standard in Horizontal level is $\bar{E}_h > 500$ and Vertical level is $\bar{E}_z = 500$ lx.
2. **Minimum required color rendering index** (R_a): The minimum requirement of color rendering index (CRI) is 80 or more for an office environment. Rendering index 90 or higher is considered as an excellent rendering quality.
3. **Maximum unified glare rating** (UGR_L): For a typical office environment, UGR_L should be 19 or less
4. **Minimum uniformity** (U_0): The standard value of a surface uniformity is 0.6

In the designed LED panel testing, the first two qualities, minimum illuminance level (\bar{E}_m) and minimum color rendering index (R_a) have been tested.

4.16 Average Illumination (\bar{E}_h) in Horizon Level

The average illuminance level for each of the 5 LED panels have been showed in table 11 below. Column two and three shows the average illumination without and with diffuser. The Illumination Engineering Society of North America (IES) average illumination measurement method has been described in previous section 4.7, column four and five shows the true average illumination without and with diffuser respectively. From the table it can be found that for the first LED panel (RGBA column matrix panel) the diffuser and the true average illumination method was not being used. As it was not possible to rearrange that panel again later, the measurements could not take for that panel. Same thing happened for the RGBA circular matrix panel, the true average illumination method literature was not found during that time, and it was not possible later to redesign the same panel in same way.

| Panel Type | IES \bar{E}_h without diffuser | IES \bar{E}_h with diffuser | True \bar{E}_h without diffuser | True \bar{E}_h with diffuser |
|---------------------------------|----------------------------------|-------------------------------|-----------------------------------|--------------------------------|
| RGBA Column Matrix | 534 | n/a | n/a | n/a |
| RGBA Circular Matrix | 562 | 181 | n/a | n/a |
| RGBA Randomized Circular Matrix | 617 | 198 | 734 | 199 |
| 13 LEDs Max Melanopic-Lux | 107 | 67 | 132 | 112 |
| 13 LEDs Min Melanopic-Lux | 133 | 51 | 123 | 51 |

Table 11: Gained illuminance level (IES average illumination and true average illumination), the illuminance level are given in lux unit.

For measuring the light distribution at different measurement terminals p1, p2, p3, p4 or uniformity of the light, the Konica Minolta Chromameter CL-200 has been set up in different measurement terminals. As the illuminance level was very high immediate under the LED panel, terminal p0, that value was not measured for calculation.

From the table it has been found that, before using the diffuser the illuminance values in different measurement terminals were very different but after using the diffuser, the light in the light booth surface at different measurement terminal become more uniform and mild.

| Panel Type | Without Diffuser | | | | With Diffuser | | | |
|---------------------------------|------------------|-----|-----|-----|---------------|-----|-----|-----|
| | p1 | p2 | p3 | p4 | p1 | p2 | p3 | p4 |
| RGBA Column Matrix | 540 | 477 | 508 | 610 | 197.25 | 186 | 193 | 206 |
| RGBA Randomized Circular Matrix | 560 | 582 | 479 | 628 | 180 | 190 | 154 | 200 |
| RGBA circular ran | 595 | 616 | 458 | 799 | 199 | 177 | 195 | 222 |
| 13LED Max. Melanopic-Lux | 150 | 149 | 150 | 279 | 74 | 67 | 64 | 64 |
| 13LED Min. Melanopic-Lux | 143 | 115 | 118 | 157 | 53 | 45 | 49 | 56 |

Table 12: The uniformity of the table surface at different measurement terminals p1, p2, p3, p4 without and with diffuser; the uniformity as been measured in four different measurement points in lux unit

4.17 Color Rendering Index (Ra)

Color rendering index is an important index for commercial light design that guarantee the objects will be perceived under a particular lighting situation for human sensitivity with a natural color [71]. The color rendering indexes for each of the designed LED panels have been measured and documented for further research work using Konica Minolta Spectrophotometer CL-500A optical device. For general office environment, the color rendering index 80 is considered as good light quality for general office work, 90 or more than that is considered for excellent quality [7]. Color rendering index insures a pleasant environment to the occupants. The color rendering indexes obtained for five different LED panels have been given in table 13. From the table it has been seen that, the color rendering index obtained for three different RGBA matrix panel came in negative vale, that means no color rendering properties are found in this lighting panels. On the other hand, using 13 LED packages give a good color rendering index, especially after using the diffuser; the color rendering indexes have been improved.

| LED Panel Type | Without Diffuser | With Diffuser |
|---------------------------------|------------------|---------------|
| RGBA Column Matrix | -79 | n/a |
| RGBA Circular Matrix | -79 | -5 |
| RGBA Randomized Circular Matrix | -44 | -25 |
| 13 LED Max. Melanopic-Lux | 81 | 86 |
| 13 LED Min. Melanopic-lux | 85 | 85 |

Table 13: Color rendering indexes for different LED panels

RGB LED panels generate white light has better color rendering over normal white blue LED with yellow phosphorus. Using RGBA should improve the RGB quality. From our designed LED panels, it can be found that, the 13 LED panel gives better result in color rendering context over only RGB panels. The illumination level for these panels are lower than the RGB panels but this can be improved with using some other techniques like reflectors.

5 Conclusion and Future Research

For present time and upcoming future, energy consumption is most significant because it is commercially profitable as well as it increases the chance of better environment. To reach this goal most of the commercial buildings nowadays are being designed for best utilization of daylight through windows facades and any other means. These kinds of buildings are not only minimizing the electricity consumption but also creating new research opportunities in modern lighting. In a general indoor lighting condition, pleasant environment, balanced physical and mental health condition of the occupants and appropriate circadian rhythm with a regular sleep wake cycle are most expected.

From the recorded daylight data, in an outdoor location it has been observed that in horizon light measurement direction, each of the four directions (south, west, north and east cardinal points) has different irradiance values due the different altitude position of the sun generates different angles of the receiving sun beam in each of the directions.

For the open exterior area it has been observed that the south facade window passes maximum irradiance value and as well as this particular direction is most lighted scenario. The north and east orientation have both the lowest irradiance and illuminance although there were presence of compact fluorescent lamps and diffused glass window respectively. Research found that window in the upper position allows higher illumination than the windows located in the bottom position [72] with respect to the ground position. During the measurements in the open exterior area, the window position covered a big area of the south facade and the illumination was good for natural work proves the research work.

Further analysis with the recorded data would help finding the average daylight factor (DF), sky component (SC) and internally reflected component (IRC) with simple mathematical calculation with respect to standard lighting condition. These parameters are very important for a green building designing [73].

After a careful evaluation of the designed five different LED panels with four different matrix pattern with different irradiance mapping it can be said that the 13 LED panels have provided better result over the RGBA LED panels. From the measured values it has been found that the 13 LED panels illuminance level is quite lower than RGBA panels but it gives better color rendering index and homogeneity over the surface covered by the panel. Among only the three RGBA LED panels, the RGBA panel with randomized circular pattern has provided the best result with respect to illuminance value, color rendering and homogeneity. After installing the diffuser the light coming from the panels became more homogeneous and equi-intensity with different dominant wavelengths.

The light efficiency of the designed five LED panels can be improved using glass or plastic reflectors up to 50% [74] with different arrangements, that has been kept for future research. As the light panels are designed based on the highest circadian factors, the non-effects of these LED light can be tested under a mock office environment with real observer. Heat management feature can be installed, that currently unavailable to give these panels a commercial look and later test and compare with present LED lamps in market. The non-visual effects of light is a new invention in optical science, there are a lot of opportunities to continue further research in this field to solve many unsolvable questions and unquestioned questions as well.

Bibliography

- [1] Danny H. W. Li, Gary H. W. Cheung, K. L. Cheung, Tony N. T. Lam. 2010. *Determination of Vertical Daylight Illuminance Under Non-Overcast Sky Conditions*. The International Journal of Building Science and Its Applications, volume 45, pages 498-508.
- [2] Aparna Das, Saikat Kumar Paul. 2015. *Artificial Illumination During Daytime in Residential Buildings: Factors, Energy Implications and Future Predictions*. Applied Energy, volume 158, pages 65-85.
- [3] Danny H. W. Li. 2010. *A Review of Daylight Illuminance Determinations and Energy Implications*. International Journal of Applied Energy, volume 87, pages 2109–2118.
- [4] Azza Babil, John Mardaljevic. 2006. *Useful Daylight Illuminances: A Replacement for Daylight Factor*. International Journal of Day Lighting Buildings, volume 38, pages 905-913.
- [5] Nabil A, Mardaljevic J. 2005. *Useful Daylight Illuminance: A New Paradigm to Access Daylight in Buildings*. Lighting Research and Technology, volume 37, pages 41-59.
- [6] Laura Bellia, Alessia Pedace, Giuseppe Barbato. 2014. *Winter and Summer Analysis of Daylight Characteristics in offices*. The International Journal of Building Science and its Applications, volume 81, pages 150-161.
- [7] Shang-Hui Yang, Jian-Shian Lin, Fuh-Shyang Juang, Ding-Chin Chou, Ming-Hua Chung, Chen-Ming Chen, Lung-Chang Liu. 2013. *White Light Emitting Diodes (LEDs) with Good Color Rendering Indices (CRI) and High Luminous Efficiencies by the Encapsulation of Mixed and Double-Deck Phosphors*. Current Applied Physics, volume 13, pages 931-934.
- [8] M.M. Aman, G.B. Jasmon, H. Mokhlis, A.H.A. Bakar. 2013. *Analysis of the performance of domestic lighting lamps*. Energy Policy, volume 52, pages 482-500.
- [9] S. Neumann, S. Haverkamp and O. N. Auferkort. 2011. *Intrinsically Photosensitive Retinal Ganglion Cells of the Primate Retina Express Distinct Combinations of Inhibitory Neurotransmitter Receptors*. US National Library of Medicine, National Institute of Health. 16 August, 2015, <http://www.ncbi.nlm.nih.gov/pubmed/22044923>
- [10] Basic Research Needs for Solid-State Lighting. 2006. *Report of the Basic Energy Sciences Workshop on Solid State Lighting*.
- [11] Peng Xue, C. M. Mak, H.D. Cheung. 2014. *The Effects of Day Lighting and Human Behavior on Luminous Comfort in Residential Buildings: A Questionnaire Survey*. The International Journal of Building Science and its Applications, volume 81, pages 51-59.
- [12] Hideaki Kido, Yasuyuki Shiraishi. 2013. *Characteristics of Indoor Lighting Environment Using Daylight with a Light Shelf*. International Journal of Environmental Science and Development, volume 4, pages 36-39.
- [13] Wafa Imad Ibrahim Abu Fares, Vineetha Kalavally, Nader Karnrani, and Jussi Parkkinen. 2013. *Spectrum-Controlled LED System for Light Quality Testing*. Photonics (ICP), 2013 IEEE 4th International Conference, pages 212-214.

- [14] P. Bodrogi, S. Bruckner, K. Tran Quoc, and H. Winkler. 2013. *Visual Assessment of Light Source Color Quality. Color Research and Application*. Wiley Periodicals Inc. volume 38, pages 4-13.
- [15] Charles Kittel. *Introduction to Solid State Physics, Eighth Edition*. John Wiley & Sons, Inc. Chapters 14-15, pages 395-396, 433-434.
- [16] Naoyuki Komuro, Masayoshi Mikami, Paul J. Saines, Anthony K. Cheetham. 2015. *Structure–Property Correlations in Eu-Doped Tetra Calcium Phosphate Phosphor: A key to Solid State Lighting Application*. *Journal of Luminescence*, volume 162, pages 25-30.
- [17] N. Thejokalyani, S. J. Dhoble. 2014. *Novel Approaches for Energy Efficient Solid State Lighting by RGB Organic Light Emitting Diodes – A review*. *Renewable & Sustainable Energy Reviews*, volume 32, pages 448-467.
- [18] Donald A. Neamen, University of New Mexico. *Semiconductor Physics and Devices, Basic Principles. Third Edition, McGraw Hill Publication*. Chapters 4-5, pages 123-134, 144-146.
- [19] Masayuki Fujita. 2013. *Silicon Photonics: Nanocavity Brightness Silicon*. *Nature Photonics*, volume 7, pages 264-265.
- [20] John Orton, University of Nottingham. *Semiconductors and the Information Revolution*. Chapter 1, pages 20-21.
- [21] Susan Walsh Sanderson, Kenneth L. Simons. 2014. *Light Emitting Diodes and The Lighting Revolution: The Emergence of a Solid State Lighting Industry*. Technical Report by Rensselaer Polytechnic Institute, USA. Volume 43, pages 1730–1746.
- [22] Soyeong Ahn, Jae Neung Kim, Young Chul Kim. 2015. *Solid State Solvation Effect of a Donor-acceptor Type Fluorescent Molecule and its Application to White Organic Light-Emitting Diodes*. Selected Paper for 2014 International Conference on Electronic Materials and Nanotechnology for Green Environment (ENGE 2014) *International Journal on Current Applied Physics*, volume 15, pages 42-47.
- [23] LED Center, Online Educational Blog. 17 August, 2015. <http://led.linear1.org/why-are-leds-different-colors/>
- [24] David L. Di Laura, Kevin W. Houser, Richard G. Mistrick, Gary R. Steffy. *Illuminating Engineering Society, The Lighting Handbook, Tenth Edition*. Chapter 7. Light Sources: Technical characteristics, page 7.61.
- [25] Karlheinz Seeger. *Semiconductor Physics, An Introduction, 9th Edition*. Springer Publication, chapters 5.1-5.3, pages 72-82.
- [26] David L. Di Laura, Kevin W. Houser, Richard G. Mistrick, Gary R. Steffy. *Illumination Engineering Society, The Lighting Handbook, Tenth Edition*. Framework: Photo-biology and Non-visual Effect of Optical Radiation, pages: 3.3-3.7.
- [27] Mariá L. Ámundadóttir, Steven W. Lockley, and Marilyne Andersen. 2013. *Simulation–Based Evaluation of Non–Visual Responses to Daylight: Proof of Concept Study of Health Care Re-Design*. *The International Journal of Building Science and its Applications*. volume 70, pages 138–149.
- [28] Andrea Sand, Tiffany M. Schmidt, Paulo Kofuji. 2012. *Diverse Types of Ganglion Cell Photoreceptors in The Mammalian Retina*. US National Library of Medicine, National Institute of Health. 16 August, 2015, <http://www.ncbi.nlm.nih.gov/pubmed/22480975>

- [29] Jennifer *et al.* 2010. *Melanopsin-Expressing Retinal Ganglion-Cell Photoreceptors: Cellular Diversity and Role in Pattern Vision*. US National Library of Medicine, National Institute of Health, volume 67, pages 49–60.
- [30] Tiffany M. Schmidt, Shih-Kuo Chen and Samer Hattar. 2011. *Intrinsically Photosensitive Retinal Ganglion Cells: Many Sub-types, Diverse Functions*. US National Library of Medicine, National Institute of Health, volume 34, pages 572–580.
- [31] Shelley A. Tischkau, Stacey L. Krager. 1995. *Orchestration of the Circadian Clock Network by the Suprachiasmatic Nucleus*. US National Library of Medicine, National Institute of Health, volume 14, pages 697–706.
- [32] Sand, A., Schmidt, T.M., and Kofuji, 2012. *Diverse Types of Ganglion Cell Photoreceptors in The Mammalian Retina*. US National Library of Medicine, National Institute of Health, volume 31, pages 287–302.
- [33] A Barroso, K Simons and P de Jager. 2014. *Metrics of Circadian Lighting for Clinical Investigations*. Sage Journals, volume, 46, pages, 637–649.
- [34] Li Lan, Zhiwei Lian, Li Pan, Qian Ye. 2009. *Neurobehavioral Approach for Evaluation of Office Workers' Productivity: The Effects of Room Temperature* The International Journal of Building Science and its Applications, volume 44, pages 1578–1588.
- [35] Claude Gronfier, Richard Zarytkiewicz, Jean-Jacques Ezrati. 2014. *Everyday Health, A New Issue in Lighting Design*. Online Journal, 16 August, 2015. http://www.academia.edu/10844972/Every_Day_Health_a_New_Issue_in_Lighting_Design
- [36] Tara A. LeGates, Diego C. Fernandez, and Samer Hattar. 2014. *Light as a Central Modulator of Circadian Rhythms, Sleep and Affect*. Nature Reviews Neuro-science, volume 15, pages 443-454.
- [37] Brian Owen. 2015. *Dark-Sky Says Boo to Blue Light* LEDs Magazine, 16 August 2015. <http://www.ledsmagazine.com/articles/2009/10/dark-sky-says-boo-to-blue-light.html>
- [38] Robert J Lucas, Stuart N Peirson†, David Berson, Timothy Brown, Howard Cooper, Charles A Czeisler, Mariana G Figueiro, Paul D Gamlin, Steven W Lockley, John B O'Hagan, Luke L A Price, Ignacio Provencio, Debra J Skene, George Brainard. Oxford 18th, 2013. Irradiance Toolbox: User Guide, page 7.
- [39] N. Lena. 2002. *Lighting Measurements*. Illuminating Engineering Society of North America, Light Measurements Handbook, page 17.
- [40] L. Beilila, F. Bisegna. 2013. *From Radiometry to Circadian Photometry: A Theoretical Approach*. International Journal of Building and Environment, volume 62, pages 63-68.
- [41] Joseph A. Shaw. *A Basics of Radiometry and Photometry*. Technical Report, Montana State University Electro Optical Systems (EELE 482 F12).
- [42] James M. Palmer, Barbara G. Grant. 2007. *The Art of Radiometry*, page 393. 16 August 2015. <http://fp.optics.arizona.edu/Palmer/rpfaq/rpfaq.htm>
- [43] Lighting and Energy Standards and Codes. 2010. *International Commission on Illumination annual report* Chapter 4.
- [44] Evan Mills, Nils Borg. 1999. *Trends In Recommended Illuminance Levels: An International Comparison*. Journal of the Illuminating Engineering Society, volume 26, pages 225-237.

- [45] C. F. Reinhart. 2002. *Effects of Interior Design on the Daylight Availability in Open Plan Offices*. Conference Proceedings of the ACEEE Summer Study on Energy Efficient Buildings, volume 43, pages 1–12.
- [46] Photo Voltic Educational Network, August 17, 2015. <http://www.pveducation.org/pvcdrom/properties-of-sunlight/measurement-of-solar-radiation>
- [47] Jaehyuk Yoon, Mintaek Kim, Seunghyeon Lee, Kwang Min Chun, Soonho Song. 2015. *Real Time Light Transmission Spectroscopy (RTLTS): A Real Time and in Situ Particle Size Distribution Measurement for Fractal-Like Diesel Exhaust Particles*. Journal of Aerosol Science, volume 90, pages 124-135
- [48] M.Deru, N. Blair, and P.Torcellini. 2005. *Procedure to Measure Indoor Lighting Energy Performance* National Renewable Energy Laboratory, US Department of Energy, Technical Report NREL/TP-550-38602.
- [49] EE Richman. 2012. *Standard Measurement and Verification Plan for Lighting Retrofit Projects for Building and Building sites*. Pacific Northwest National Laboratory, US Department of Energy. Technical Report, DE-AC05-76RL01830
- [50] Amy Camie 2014. *Day Lighting Offices, a First Step Forward an Analysis of Photobiological Effects for Design Practice Purpose*. International Journal of Building and Environment, volume 39, pages 54-64.
- [51] L. Bellia, A. Pedace, G. Barbato. 2013. *Lighting in Educational Environment: an Example of Compute Analysis of the Effect of Daylight and Electric Light on Occupants*. International Journal of Building and Environment, volume 68, pages: 50-65.
- [52] Peter Thorns. 2011. *Light and Lighting-Light of Workplaces. Part 1: Indoor Work Places; CIE-12464-1*. International Commission on Illumination.
- [53] 2008. *Lighting Assessment in the Work Place, Occupational Safety and Health Branch, Labor Department, Hong Kong*.
- [54] Koven AL 1963. *How to Make Lighting Survey*. Joint Lighting Survey Committee. Illumination Engineering Society, volume 57, pages 87-100.
- [55] Todd Mitton. 2015. *The Wealth of Sub-Nations: Geography, Institutions, and Within-Country Development*. Journal of Development Economics, volume 118, pages 88-111.
- [56] Richard Kittler, Miroslav Kocifaj, Stanislav Darula. 2012. *Daylight Science and Daylighting Technology*. Springer Publication, ISBN 978-1-4419-8815-7, pages 71-84.
- [57] Ana Pérez, Argimiro de Miguel, Julia Bilbao. 2010. *Daylight Illuminance on Horizontal and Vertical Surfaces for Clear Skies. Case Study of Shaded Surfaces*. The Official Journal of the International Solar Energy Society, volume 84, pages 137-143.
- [58] David L. DiLaura, Kevin W. Houser, Richard G. Mistrick, Gary R. Steffy. *Illuminating Engineering Society, The Lighting handbook 10th Edition*. Chapter 9, pages 9.29-9.31.
- [59] J.R. Cravath and V.R. Lansingh. 1908. *The Calculation of Illumination by the Flux of Light Method*. Illuminating Engineering Society (IES).
- [60] Nibedita Das, Nitai Pal, Sadhu K. Pradip 2015. *Economic Cost Analysis of LED Over HPS Flood Lights for an Efficient Exterior Lighting Design Using Solar PV*. Building and Environment, volume 89, pages 380-392.

- [61] L. Svilainis. 2008. *LED Diversity Measurement in Situ. Measurement*. Journal of The International Measurement Confederation, volume 41, pages 647–654.
- [62] David Kim. 2015. *Chapter 300–White LED Driver in Tiny SC70 Package Delivers High Efficiency and Uniform LED Brightness*. Analog Circuit Design, volume 3, pages 643-644.
- [63] Young-Pil Kim, Young-Shin Kim, Seok-Cheol Ko. 2015. *Thermal Characteristics and Fabrication of Silicon Sub-Mount Based LED Package*. Microelectronics Reliability, volume 27, pages 153-155.
- [64] Jonathan Wafer, Osram Opto Semiconductors Inc. 2004. *LEDs Meet Solid-State Electronics, White LEDs Face Design Challenges*. Photonics Spectra Magazine, volume 38, pages 27-29.
- [65] Online Course on LED, Philips, Netherlands, August 15, 2015. http://www.lighting.philips.com/pwc_li/main/connect/Lighting_University/internet-courses/LEDs/led-lamps5.html
- [66] Zhang Deng, Yang Jiang, Ziguang Ma, Wenxin Wang, Haiqiang Jia, Junming Zhou and Hong chen. 2015. *A Novel Wavelength Adjusting Method in InGaN Based Light Emitting Diodes*. Superlattices and Microstructures, volume 83, pages 176–183.
- [67] Alex Ryer. 1998. *Light Measurement Handbook*. International Light Technologies. August 16, 2015. <http://www.intl-lighttech.com/services/ilt-light-measurement-handbook>
- [68] Lidan Miao, Hairong Qi. 2006. *The Design and Evaluation of a Generic Method for Generating Mosaicked Multispectral Filter Arrays*. IEEE Transactions on Image Processing, volume 15, pages 2780-2791.
- [69] Raju Shrestha , Jon Y. Hardberg. 2013. *LED Matrix Design for Multispectral Imaging*. Color and Imaging Conference (CIC) on Color Scienec and Engineering Systems, Technologies and Applications, volume 7, pages 8-13.
- [70] LED Luminaire Design Guide. CREE, Inc. *Application Note: CLD-AP15 REV 0B*
- [71] Jing Yu, Yongming Yin, Wenbo Liu, Wei Zhang, Letian Zhang, Wenfa Xie, Hongyu Zhao. 2014. *Effect of the Greenish-Yellow Emission on the Color Rendering Index of White Organic Light-Emitting Devices*. Organic Electronics, volume 15, pages 2817-2821.
- [72] Madhu Sudan, G.N. Tiwari, I.M. Al-Helal. 2015. *A Daylight Factor Model Under Clear Sky Conditions for Building: An Experimental Validation*. The Official Journal of the International Solar Energy Society, volume 115, pages 379-389.
- [73] Madhu Sudana, G.N. Tiwaria, I.M. Al-Helal. 2015. *A Daylight Factor Model Under Clear Sky Conditions for Building: An Experimental Validation*. Solar Energy, volume 115, pages 379-389.
- [74] Heng Wu, Xian min Zhang, Peng Ge. 2015. *Design Method of a Light Emitting Diode Front Fog Lamp Based on a Free form Reflector*. International Journal on Optics & Laser Technology, volume 72, pages 125-133.