

## DESIGN AND ANALYSIS OF A PARALLEL MECHANISM FOR KINEMATICALLY REDUNDANT HYBRID PLANAR LASER CUTTING MACHINE

**M. İ. Can DEDE**, *candede@iyte.edu.tr* İzmir Institute of Technology, 35430, İzmir, Turkey

**Erkin GEZGİN**, *erkin.gezgin@ikcu.edu.tr* İzmir Katip Çelebi University, 35620, İzmir, Turkey

**Gökhan KİPER**, *gokhankiper@iyte.edu.tr* İzmir Institute of Technology, 35430, İzmir, Turkey

**Ercan MASTAR**, *emastar@coskunuz.com.tr* Coşkunöz Metal Form, 16159, Bursa, Turkey

**Tayfun SİĞİRTMAÇ**, *tsigirtmac@coskunuz.com.tr* Coşkunöz Metal Form, 16159, Bursa, Turkey

**Emre UZUNOĞLU**, *emreuzunoglu@iyte.edu.tr* İzmir Institute of Technology, 35430, İzmir, Turkey

### ABSTRACT

Conventional planar laser cutting machines cannot achieve high accelerations, because the required precision values cannot be achieved due to the high inertial loads. Machines configured as kinematically redundant mechanisms are able to reach 5-6 g acceleration levels since they include a parallel mechanism with a smaller workspace which is exposed to smaller inertial loads. The study presented in this paper focuses on the design of a parallel planar mechanism to be integrated to the main axes of conventional planar laser cutting machines to achieve higher accelerations of the laser head up to 6 g. Parallel mechanism's conceptual design and dynamic balancing studies are provided along with the joint clearance effect on precision due to having more joint structures.

**Keywords:** Kinematically redundant machine, Planar laser cutting machine, Dynamic balancing, Joint clearance

### 1. INTRODUCTION

Planar laser cutting machines traditionally are built with two linear axes, along x and y direction. They also include a linear motion along z axis (normal to the workpiece) to adjust

laser head's distance with respect to the irregularities of the workpiece. Amount of time spent for cutting a specific workpiece (usually a benchmark workpiece) with a certain precision and repeatability is used to determine the performance of laser cutting machines. The acceleration of the laser head is critical in increasing the performance of the machine.

In laser cutting machines, the maximum cutting speed is determined by laser power, workpiece material and width [Schulz et al., 2009]. For cutting processes with multiple contours, the total cutting process time is mainly determined by transitions between contours and the time to reach the maximum cutting speed for each contour is also critical. Dynamical performance of the conventional machines is limited by vibrations due to inertial forces that occur because of high linear accelerations required during these transitions. Redundantly actuated systems with high acceleration capabilities are developed to overcome this problem. Trumpf Co. [Leibinger et al., 2004] and Amada Co. [Masakata, 2006; Morikatsu, 2007; Taisuke, 2009] integrated an extra local axis parallel to X or Y axes (XY+x or XY+y motion). Prima Co. [Sartorio, 2004; Gattiglio et al., 2008, 2011] developed a more dynamic system with a PPPP (P: prismatic joint) mechanism that can provide accelerations above 6 g (XY+xy motion). Finally, Salvagnini Co. [Battheu, 2011, 2012] developed a system which can reach 5 g acceleration levels with a PRRRP (R: revolute joint) parallel mechanism that provides  $y\theta$  motion in addition to motion along X-axis (X+y $\theta$  motion). However, there are no applications of well-known RRRR (4R) or RRRRR (5R) planar mechanisms (XY+ $\theta$  or XY+ $\theta\theta$  motion) for 2-D laser cutting machines.

In general, redundant manipulators are used to avoid singularities, enlarge the workspace, enhance stiffness, controllability, transmission properties [Xie et al., 2011], and improve the dynamic behavior. In this study, we aim to increase the performance of a planar laser cutting machine by configuring the machine as a kinematically redundant hybrid mechanism. Therefore, it will embrace the advantages of both kinematic redundancy and parallel mechanisms. Conceptual design studies for the parallel mechanism are given in the next section. Dynamic balancing studies for the parallel mechanism in order to minimize the vibrations due to high accelerations and thus, increase the precision and repeatability are provided in Section 3. In Section 4, joint clearance effect on the precision of the mechanism is investigated by making use of the fact that for kinematically redundant mechanisms there are more joint structures than minimally required. Section 5 concludes the paper.

## 2. CONCEPTUAL DESIGN STUDIES

Structural layout of the kinematically redundant hybrid manipulator consists of a 2 degrees-of-freedom (DoF) serial Cartesian manipulator and a 2-DoF parallel mechanism. The serial Cartesian manipulator is utilized for relatively lower acceleration and coarse movements, while the latter one ensures rapid and fine planar positioning of the cutting head. The reason for choosing a parallel mechanism instead of a serial one is that parallel mechanisms have better positioning performance with respect to serial mechanisms due to the fact that joint clearance effects do not accumulate as it is in serial mechanisms. This fact is well explained in [Briot, Bonev, 2007].

For selecting the parallel mechanism for rapid and precise planar positioning, alternatives for single loop planar 2-DoF parallel manipulators with simple joints (revolute (R) and prismatic (P)) are evaluated. Mobility calculation immediately reveals that such a mechanism consists of 5 links and 5 joints. The number of P joints cannot exceed 2, because otherwise the mechanism has an extra uncontrollable DoF [Söylemez, 2009]. There are 32 such mechanisms, but we decrease this number by setting some basic rules as: The fixed joints should be actuated; If exists, prismatic joints should be actuated; Mirror images are counted as one (ex.  $\underline{RRRPR} = \underline{RPRRR}$ ); No actuated joint should bear the load from the other actuated joint (ex.  $\underline{RPRRR}$  is not suitable). Complying these rules, there are 6 possible 5-link mechanisms:  $\underline{RRRRR}$ ,  $\underline{RRRPR}$ ,  $\underline{RRRRP}$ ,  $\underline{RPRRP}$ ,  $\underline{RPRPR}$ ,  $\underline{PRRRP}$  [Cervantes-Sánchez, Rendón-Sánchez, 1999]. Due to workspace symmetry requirement, balancing requirement and ease of control, generally symmetrical structures are preferred [Sun, Cheung, Lou, 2007]. Also, the  $\underline{RPRPR}$  mechanism is problematic due to the inertia of the pistons. Therefore, we shall concentrate on the  $\underline{RRRRR}$  (5R) and  $\underline{PRRRP}$  alternatives (Figure 1).

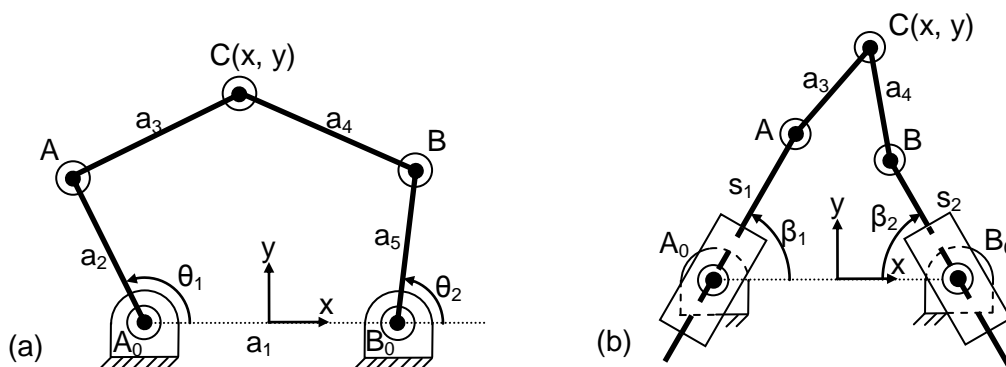

Figure 1. (a) Planar 5R Mechanism and (b) Planar  $\underline{PRRRP}$  mechanism

### 5R Mechanism

The kinematic diagram of the 5R mechanism is shown in Figure 1(a). The 5R mechanism is one of the most commonly used planar 2-DoF parallel mechanisms [Giberti et al., 2011] as

an alternative to the 2R serial manipulator since 1980s [Asada, Youcef-Toumi, 1984]. According to Alici and Shirinzadeh [2003], the 5R mechanism is the only multi-crank mechanism that has practical importance, especially for following any arbitrary planar curve precisely, which cannot be handled with single DoF mechanisms. Some application areas of the 5R manipulator are: assembly robot [Munakata, 1988], transportation robot [Shuichi, Shige, 1990], positioning device [Karidis et al., 1992], haptic device [Hayward et al., 1994], medical device [Yoshino et al., 2005]. The mini positioning device developed in IBM can reach acceleration values above 50g [Karidis et al., 1992]. Also, there are several studies on the control and balancing of the 5R mechanism [Shiller, Sundar, 1993; Ouyang et al., 2003; Alici, Shirinzadeh, 2004; He, Lu, 2006; Gonçalves et al., 2008].

In a 5R mechanism, fixed joints are actuated and the point C is positioned to the desired coordinates by varying the joint angles  $\theta_1$  and  $\theta_2$ . The kinematics of the 5R mechanism is relatively simple. The mechanism workspace, i.e. the possible locations for point C, is given by the intersection of the circle with radius  $a_2 + a_3$ , center  $A_0$  and the circle with radius  $a_4 + a_5$ , center  $B_0$  [Feng et al., 1996]. The intersection area is always symmetric with respect to the x-axis (Figure 1.a). Usually the arms  $A_0AC$  and  $B_0BC$  are chosen identical, i.e.  $a_2 = a_5$ ,  $a_3 = a_4$ , in which the workspace is also symmetrical with respect to the y-axis. In many applications, the actuated joint axes are chosen to be concurrent, i.e.  $a_1 = 0$  [Shuichi, Shige, 1990; Isaakson, 2011]. In this case, the workspace is a circular area. The advantage of this structure is that the whole mechanism can be rotated  $360^\circ$  without any singularities and the workspace is relatively large [Isaakson, 2011].

### **PRRRP Mechanism**

The kinematic diagram of the PRRRP mechanism is shown in Figure 1(b). In most of the applications,  $\beta_1 = \beta_2 = \beta$ . Hanak et al. [2002] used a PRRRP mechanism with  $\beta = 0^\circ$  as a high precision inspection device. Salvagnini Co. [Battheu, 2011, 2012] made use of a PRRRP mechanism with  $\beta = 0^\circ$  as a part of a kinematically redundant planar laser cutting machine and it is claimed that the end-effector of this machine can reach up to 5g acceleration. Li et al. [2007] have studied use of a PRRRP mechanism with  $\beta = 45^\circ$  in a micro-electric production line as a packaging and assembly device. Wu et al. [2007] have combined a serial PR chain with a PRRRP mechanism with  $\beta = 90^\circ$  for a machining device.

### **Comparison of the Mechanisms**

Sun, Cheung and Lou [2007] have compared a 5R and a PRRRP mechanism, link length dimensions of which are optimized for the same square workspace, in terms of compactness and singularity. According to the results, a relatively compact 5R mechanism can achieve the same task carried out with a relatively larger PRRRP mechanism. The 5R mechanism has

advantages of light-weight, accuracy, stiffness and better force transmission characteristics with respect to the  $\underline{P}RRRP$  mechanism. These merits provide a reduced motor power requirement and make the mechanism suitable for higher acceleration applications. On the other hand,  $\underline{P}RRRP$  mechanism has the advantages of high speed capability of the end-effector, hence it is a good alternative for pick-and-place applications. In the light of these considerations, we concluded that a 5R mechanism is more suitable for a rapid and precise planar positioning device.

## 5R Mechanism Design

It is known that a symmetric 5R mechanism has maximal workspace when the fixed revolute joints have concurrent axes [Liu et al. 2006]. Also, if the four moving links constitute a parallelogram, system dynamics becomes much neater due to parallel moving links and also dynamic balancing becomes easier [van der Wijk, Herder, 2009]. Therefore a 5R mechanism with concurrent fixed joint axes and equal moving link lengths is selected for the application.

A 5R mechanism can be used to position the axes of the distal joint, however this causes two problems: first, the laser head has dimensions comparable with the link lengths, so constructional problems may arise; second, the mechanism cannot keep the orientation of the laser head constant if no extra means are utilized. Some alternative configurations are constructed with respect to the above-mentioned problems. The first two alternatives have coaxial actuators, where the laser cutting head is placed either on the axis of the front joint, or fixed to one of the distal links (Figure 2(a), (b)). Other two alternatives are a modified form of a 5R mechanism, actually a 6R mechanism, where there is an equal offset between the actuators and moving platform joint axes (Figure 2(c), (d)).

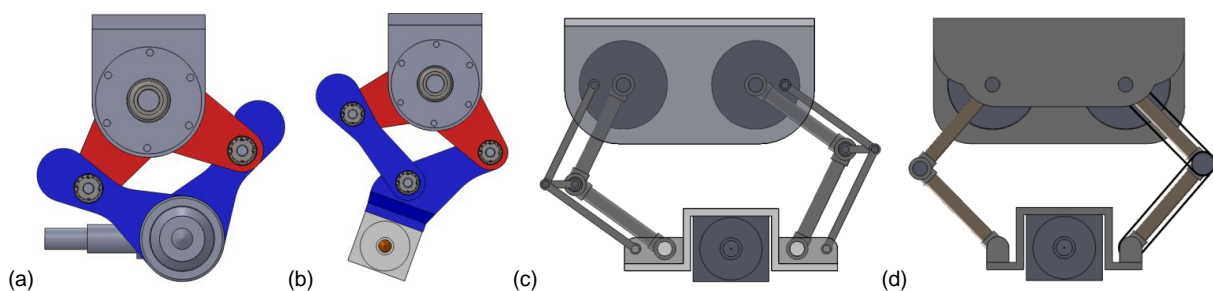

Figure 2. (a) 5R configuration where the laser head is placed on the third joint axis, (b) 5R configuration where the laser head is fixed on the front link, (c) Modified 6R configuration with parallelogram closed loops, (d) Modified 6R configuration with belts

The advantages and disadvantages of these four mechanism configurations are listed in Table 1. Modified 6R configuration with parallelogram loops is chosen as best design for the rapid and precise planar positioning device.

Table 1. Advantages and disadvantages of alternative mechanism configurations

	Modified 6R with parallelogram closed loops	Modified 6R with belts	5R, laser head is placed on to the front joint axis	5R, laser head is fixed on to the front joint link
<b>Orientation of the laser head</b>	fixed	fixed	variable	variable
<b>Actuator axes</b>	separate	separate	collinear	collinear
<b>Compactness (Plane)</b>	-	-	compact	compact
<b>Compactness (Vertical axis)</b>	compact	compact	-	-
<b>Footprint</b>	large	large	small	small
<b>Control</b>	simple	simple	complex	complex
<b>Laser Cutting Head</b>	standard	standard	special design	standard
<b>Dynamic Balancing</b>	easy	complex (belt elasticity)	easy	complex (asymmetrical)

### 3. DYNAMIC BALANCING

Forces and moments applied at the base of a mechanism result in vibrations and hence, loss of positioning accuracy. An efficient way to prevent vibrations is to balance the mechanism. Full dynamic force balancing of a mechanism is achieved if linear momentum of the mechanism is constant at all times [van der Wijk, Herder, 2009].

Due to special choice of link lengths of our mechanism, all links are either parallel to the base (y axis), or to one of the proximal arms (with angle  $\theta_1$  or  $\theta_2$ ). Therefore, the linear and angular momentum expressions can be formulated in terms of only two variables and constant terms. So, we expect that two balancing masses are enough for full dynamic force balancing and four balancing masses are required for full dynamic moment balancing. van der Wijk and Herder [2009] present simple means for full passive dynamic balancing of a 5R mechanism with coincident fixed joint axes and parallel links. It can easily be shown that the same procedure can be used for the hexagonal construction introduced in Section 2. Initial calculations show that fully balancing a mechanism requires addition of balancing masses of about 9 times the end-effector load. This means that the motors are exposed to 10 times greater loading. More powerful motors mean larger motors with less dynamic capability. Hence, although balancing improves accuracy, additional masses make the system less dynamic. Therefore, one should optimize balancing and dynamic behavior by employing partial passive balancing through additional masses and also by active balancing if required.

In view of the above discussions, we devised a passive force/active moment balancing solution for our system. Here we present the formulation of passive force balancing. The mass distribution for a 6R mechanism with two parallelogram loops on one arm is shown in

Figure 3. The end-effector mass  $m_E$  is assumed to be at midpoint of the platform CD. The distal arms AC and BD have mass  $m_F$  lumped at midpoints P and Q, respectively. The proximal arms  $A_0A$  and  $B_0B$  have mass  $m_B$  (balancing masses). Since the parallelogram loop links are parallel to the links of the 6R loop, their masses can be added to the mass of the parallel links. In Figure 3, only one arm has parallelogram loops, but it is also possible to add parallelogram loops to the other arm.

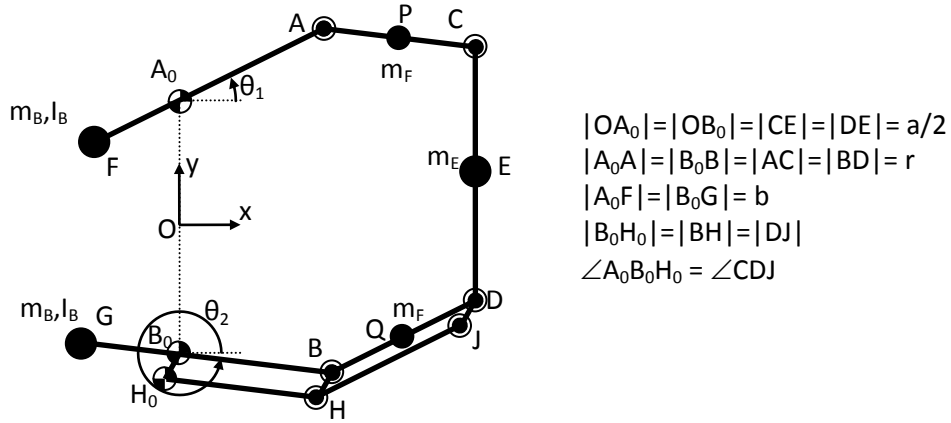

Figure 3. Mass distribution of the mechanism

The aim is to keep the center of mass of the system at coordinate frame origin O and the condition for this is

$$m_E \vec{r}_E + m_F \vec{r}_P + m_F \vec{r}_Q + m_B \vec{r}_F + m_B \vec{r}_G = \vec{0} \quad (1)$$

If we express the vectors in terms of complex numbers, (1) becomes

$$\begin{aligned} \vec{r}_E &\rightarrow ia/2 + re^{i\theta_1} + re^{i\theta_2} - ia/2, \vec{r}_P \rightarrow ia/2 + re^{i\theta_1} + (r/2)e^{i\theta_2}, \\ \vec{r}_Q &\rightarrow -ia/2 + re^{i\theta_2} + (r/2)e^{i\theta_1}, \vec{r}_F \rightarrow ia/2 - be^{i\theta_1} \text{ and } \vec{r}_G \rightarrow -ia/2 - be^{i\theta_2} \end{aligned} \quad (2)$$

$$\Rightarrow (rm_E + 1.5rm_F - bm_B)(e^{i\theta_1} + e^{i\theta_2}) = 0$$

In order for this equality to hold for all  $\theta_1$  and  $\theta_2$  values

$$rm_E + 1.5rm_F - bm_B = 0 \quad (3)$$

Typically,  $b < r/2$ , so  $m_B > 2m_E + 1.5m_F$ . In practice,  $m_F$  is quite smaller than  $m_E$ , so the total balancing mass is larger than 4 times the end effector mass. Due to the moment arm, the smaller  $b$  is, the smaller the required torque is. However, smaller  $b$  means larger balancing mass. Dynamic analyses show that the torque requirement of fully balanced system is about 2~2.5 times more than the unbalanced system. Partial balancing is also possible. The optimized amount of balancing mass can be determined by means of tests on prototypes.

#### 4. TIP POINT POSITION ERROR ANALYSIS DUE TO JOINT CLEARANCE

Joint clearance is considered to be a problem for developing mechanisms with increased precision. Joint clearance problem in mechanisms are studied for kinematic sensitivity [Tsai, Lai, 2004], dynamics [Parenti-Castelli, Venanzi, 2005], accuracy analysis [Tsai, Lai, 2008; Ting et. al, 2000] and uncertainty analysis [Zhu, Ting, 2000]. Various clearance models have been used in these studies. A general approach is to have a clearance radius (Figure 4(a)) and make use of an extra revolute joint with a link attached that has clearance radius length. This model can be depicted in Figure 4(b). In this study, in order to cover the full range of clearance, two different models are considered.

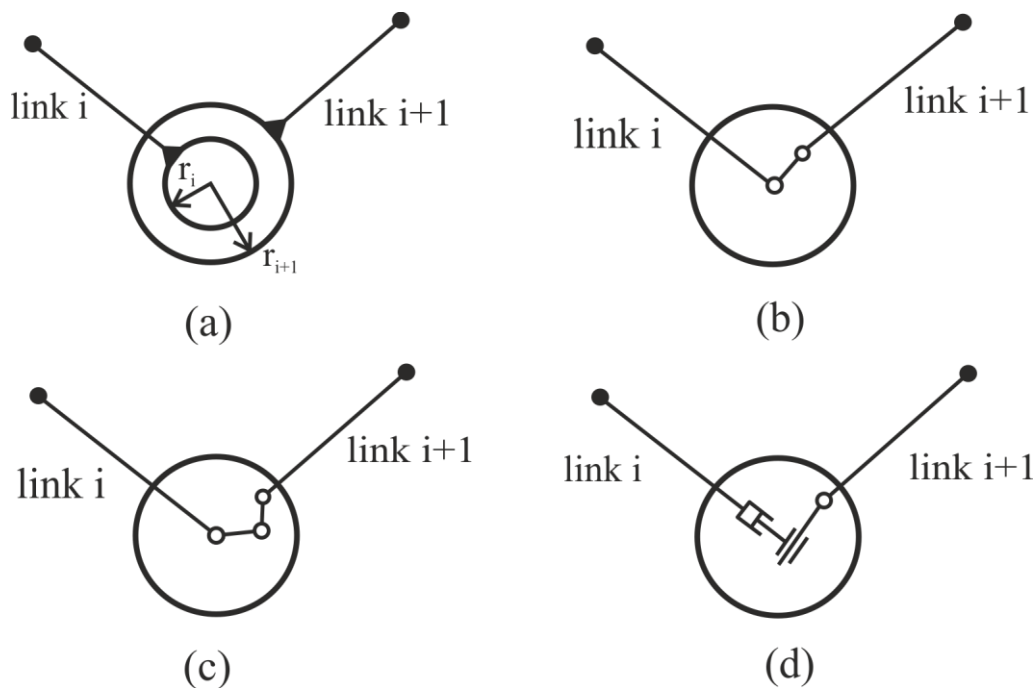

Figure 4. (a) Joint clearance general representation; (b) Generalized model with 2R; (c) 3R model; (d) PPR model

In the first model, 3R planar mechanism is used to connect the clearance circle to the next link's pin circle. Main reason to have a 3R is to allow the pin circle move within the clearance circle keeping the designated rotation of the next link unaffected. This model is presented in Figure 4(c). A problem of this model is the singularities within the workspace. A careful implementation of this model is required to be used as a fail-proof joint clearance model.

Including the 3R model, most of the joint clearance models are shape-closed or in other words, limited by their structure. The second model is a force-closed PPR chain, which includes an impact model. This method resembles the physical phenomenon with increased precision with respect to the previous models. Nevertheless, a good knowledge of joint clearance circle and pin circle material is required. The model is presented in Figure 4(d).



During the simulations when the mechanism is moving at high speeds, joint clearance circle and pin circle interaction modeling by using only stiffness values are called for very small sampling periods. This resulted in longer simulation duration. Therefore, a damping coefficient is integrated in the model to decrease the simulation duration. Model is developed in Matlab Simulink as it can be seen in Figure 5. In algorithm of this model, first, the interaction is determined and then, the related forces as a result of the interaction are calculated and the prismatic axes along x- and y-axes are driven.

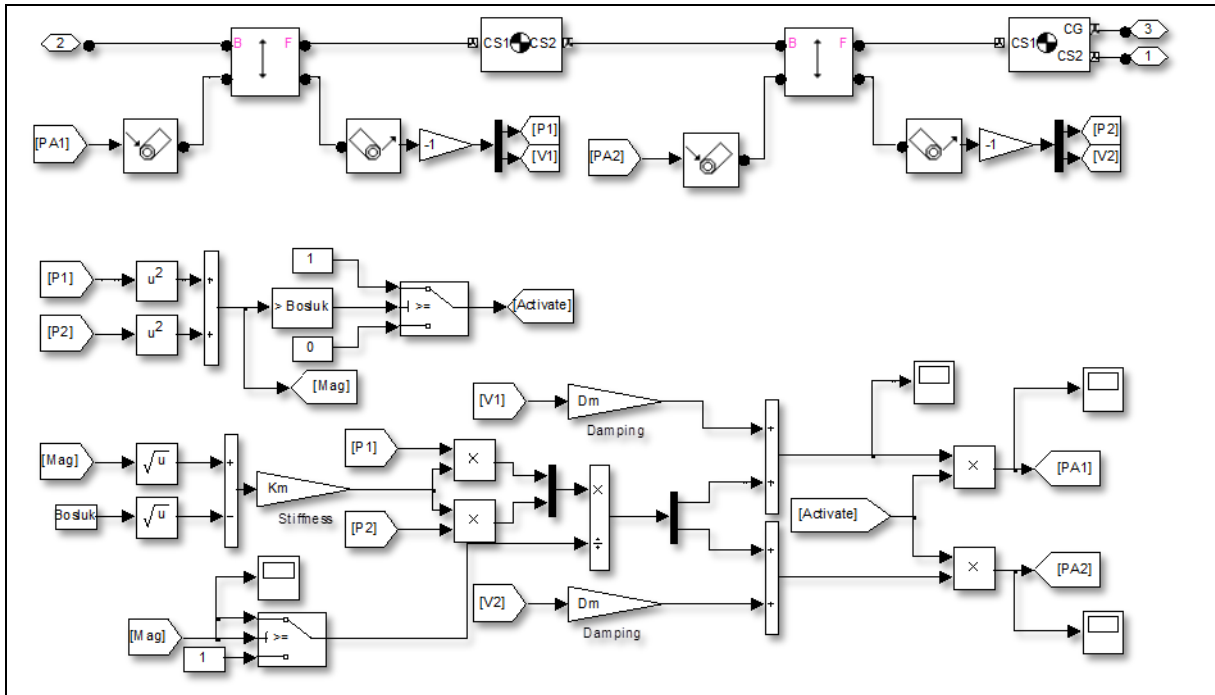

Figure 5. Matlab Simulink model of the force-closed joint clearance model

Although the mechanism studied in this study has more than six revolute joints due to the parallelograms to fix the orientation of the moving platform, simplified version without the parallelograms is used for this analysis. In order not to have an extra free DoF, the mechanism is modified to a 5R mechanism without the loss of generality since the distance between the joints on the ground and the moving platform are the same. The joint clearance on each joint is taken as 0.01 mm. Motion of the platform is specified as a motion along the x-axis. Therefore, both actuators located at the ground joints are driven with equal motion profiles but in opposite directions. As a result of the simulation test, deviation from the designated path is calculated to be 0.005 mm for the tip point. These results comply with the results of [Briot, Bonev, 2007].

## 5. CONCLUSIONS

A parallel planar mechanism design for use in a kinematically redundant planar laser cutting machine is presented in this paper. After providing the motivation for the study, background information on previous studies is given. Conceptual design alternatives for the mechanism are proposed and evaluated. Dynamic balancing studies are conducted and results indicate that the full balancing does not provide the optimal solution for required dynamic behavior for the mechanism. Joint clearance study for the parallel mechanism indicated that although the number of joints increases total effect of joint clearance on precision is minimized due to using a parallel mechanism in which the joint error are not accumulated but shared. Future work regarding mechanism studies includes prototype tests.

## Acknowledgements

This study is granted by Republic of Turkey Ministry of Science, Industry and Technology and Coşkunöz Metal Form (Project code: 01668.STZ.2012-2). The authors thank to Prof. Dr. Eres Söylemez and Mr. Hakan Demir for sharing their valuable experience and knowledge.

## REFERENCES

- Asada, H., Youcef-Toumi, K. (1984)**, "Analysis and Design of a Direct-Drive Arm With a Five-Bar-Link Parallel Drive Mechanism", *J. Dyn. Syst. Meas. Contr.*, Vol.106, pp 255-230.
- Alici, G., Shirinzadeh, B. (2003)**, "Constrained Structural Optimisation of a Revolute-Jointed Planar Parallel Manipulator", *Proceedings of IEEE/ASME Int. Conf. Advanced Intelligent Mechatronics, Kobe*, pp 1244-1249.
- Alici, G., Shirinzadeh, B. (2004)**, "Optimum Synthesis of Planar Parallel Manipulators Based on Kinematic Isotropy and Force Balancing", *Robotica*, Vol.22, pp 97-108.
- Battheu, C. (2011)**, Manipulator of Low Inertia for Laser Cutting Machines for Flat Sheet Metals, Patent no: US20110017714.
- Battheu, C. (2012)**, Combined Machine for Punching and Laser Cutting of Flat Sheet Metal, Patent no: US20120097652.
- Briot, S., Bonev, I. A. (2007)**, "Are Parallel Robots More Accurate Than Serial Robots?", *Trans. CSME*, Vol.31, No.4, pp 445-456.

**Cervantes-Sánchez, J. J., Rendón-Sánchez, J. G. (1999)**, “A Simplified Approach for Obtaining the Workspace of a Class of 2-dof Planar Parallel Manipulators”, *Mech. Mach. Theory*, Vol.34, pp 1057-1073.

**Feng, G., Xiao-Qiu, Z., Yong-Sheng, Z., Hong-Rui, W. (1996)**, “A Physical Model of the Solution Space and the Atlas of the Reachable Workspace for 2-dof Parallel Planar Manipulators”, *Mech. Mach. Theory*, Vol.31, No.2, pp 173-184.

**Gattiglio, M., Sartorio, F., Chirico, M. (2008)**, Laser Machine Tool, Patent no: US20080197118.

**Gattiglio, M., Chirico, M. (2011)**, Laser Punching Machine, Patent no: US8076610.

**Giberti, H., Cinquemani, S., Ambrosetti, S. (2011)**, “A Geometrical Index to evaluate the Kinematical Properties of a 2 dof Parallel Kinematic Manipulator”, *Proceedings of 4<sup>th</sup> Int. Multi Conf. Engineering and Technological Innovation*, Orlando, Florida, pp 1-6.

**Gonçalves, R. S., dos Santos, R. R., Carvalho, J. C. M. (2008)**, “On the Performance of Strategies for the Path Planning of a 5R Symmetrical Parallel Manipulator”, *Proceedings of 7<sup>th</sup> Brazilian Conf. on Dynamics, Control and Applications*, Sao Paulo.

**Hanak, T. R., Zirn, O., Ruoff, W. (2002)**, “2 DOF Dynamic Accuracy Monitoring for Robot and Machine Tool Manipulators”, *ASPE's 17<sup>th</sup> Annual Meeting*.

**Hayward, V., Choksi, J., Lanvin, G., Ramstein, C. (1994)**, “Design and Multi-Objective Optimization of a Linkage for a Haptic Interface”, In: *Lenarčič, A. J., Ravani, B. (Eds.): Advances in Robot Kinematics and Computational Geometry*, Kluwer Academic Publishers, pp 359-368.

**He, G., Lu, Z. (2006)**. “Optimum Motion Planning of Parallel Redundant Mechanisms with Shaking Force Reduction”, *Proceedings of IMACS Multi-conference on Computational Engineering in Systems Applications*, Beijing, pp 1132-1139.

**Isaakson, M. (2011)**. “A Family of Planar Parallel Manipulators”, *Proceedings of 2011 IRRR Int. Conf. on Robotics and Automation*, pp 2737-2744.

**Karidis, J. P., McVicker, G., Pawletko, J. P., Zai, L. C., Goldowsky, M., Brown, R. E., Comulada, R. R. (1992)**, “The Hummingbird Mminipositioner - Providing Three-Axis Motion at 50 g's With Low Reactions”, *Proceedings of IEEE Int. Conf. Robotics and Automation*, Nice, pp 685-692.

**Leibinger, P., Rauser, T., Zeygerman, L. (2004)**, Laser Cutting Machine with Multiple Drives, Patent no: US20040178181.

**Li, J., Liu, Y., Sun, L. (2007).** “A Novel 2-DOF Planar Parallel Robot with High Accelerate-High Precision”, Proceedings of 2007 IEEE Int. Conf. on Robotics and Biomimetics, Sanya, pp 2189-2193.

**Liu, X-J., Wang, J., Zheng, H-J. (2006),** “Optimum Design of the 5R Symmetrical Parallel Manipulator with a Surrounded and Good-Condition Workspace”, Rob. Auton. Syst., Vol.54, pp 221-233.

**Masakata, M. (2006),** Punching and Laser Composite Machine, Patent no: JP2006088214.

**Morikatsu, M. (2007),** Laser-Punch Composite Processing Machine, Patent no: JP2007038286.

**Munakata, T. (1988),** Industrial Robot, Patent no: US4730975.

**Ouyang, P. R., Li, Q., Zhang, W. J. (2003).** “Integrated Design of Robotic Mechanisms for Force Balancing and Trajectory Tracking”, Mechatronics, Vol.13, pp 887-905.

**Parenti-Castelli, V., Venanzi, S. (2005),** “Clearance Influence Analysis on Mechanisms”, Mech. Mach. Theory, Vol. 40, pp. 1316–1329.

**Sartorio, F. (2004),** Machine Tool and Manipulator Devise Adapted to be Mounted on Such Machine, Patent no: US20040025761.

**Schulz, W., Niessen, M., Eppelt, U., Kowalick, K. (2009),** “Simulation of Laser Cutting”, In: Dowden (Ed.), The Theory of Laser Materials Processing: Heat and Mass Transfer in Modern Technology, Vol.2, pp. 21-69.

**Shiller, Z., Sundar, S. (1993).** “Design of Multi-Degree-of-Freedom Mechanisms for Optimal Dynamic Performance”, J. Mech. Des., Vol.115, 199-206.

**Shuichi, T., Shige, M. (1990),** Parallel Link Robot Arm, Patent no: US4946337.

**Söylemez, E., (2009),** Mechanisms, METU Press, 3<sup>rd</sup> Ed., Ankara.

**Sun, S., Cheung, J. W. F., Lou, Y. (2007),** “A Study on Five-Bar Manipulators for Semiconductor Packaging Applications”, Proceedings of IEEE Int. Conf. Mechatronics and Automation, Harbin, pp 1811-1816.

**Taisuke, H. (2009),** Combined Processing Machine for Laser Beam-Punch Machining, Patent no: JP2009018334.

**Tsai, M.-J., Lai, T.-H. (2004),** “Kinematic Sensitivity Analysis of Linkage with Joint Clearance Based on Transmission Quality”, Mech. Mach. Theory, Vol. 39, pp 1189–1206.

**Tsai, M.-J., Lai, T.-H. (2008)**, “Accuracy Analysis of a Multi-loop Linkage with Joint Clearances”, *Mech. Mach. Theory*, Vol. 43, pp 1141–1157.

**Ting, K.L., Zhu, J., Watkins D. (2000)**, “The Effects of Joint Clearance on Position and Orientation Deviation of Linkages and Manipulators”, *Mech. Mach. Theory*, Vol. 35, pp 391-401.

**van der Wijk, V., Herder, J. L. (2009)**, “Synthesis of Dynamically Balanced Mechanisms by Using Counter-Rotary Counter-mass Balanced Double Pendula”, *J. Mech. Des.*, Vol.131, 111003.

**Wu, J., Wang, J., Li, T., Wang, L. (2007)**, "Analysis and Application of a 2-DOF Planar Parallel Mechanism", *J. Mech. Des.*, Vol.129, pp 434-437.

**Yoshino, I., Yasunaga, T., Hashizume, M., Maehara, Y. (2005)**, “A Novel Endoscope Manipulator, Naviot, Enables Solo-Surgery to be Performed During Video-Assisted Thoracic Surgery. *Interact. Cardiovasc. Thorac. Surg.*, Vol.4, pp 404-405.

**Xie, F., Liu, X-J., Chen, X., Wang, J. (2011)**, “Optimum Kinematic Design of a 3-dof Parallel Kinematic Manipulator With Actuation Redundancy”, In: Jeschke, S., Liu, H., Schilberg, D. (Eds.), *Intelligent Robotics and Applications – ICIRA 2011*, Vol.1, Springer, pp 250-259.

**Zhu, J., Ting, K.L. (2000)**, “Uncertainty Analysis of Planar and Spatial Robots with Joint Clearances”, *Mech. Mach. Theory*, Vol. 35, pp 1239-1256.