

**THE EVOLUTION AND CHANGE OF BUILDING
FACADES:
A RESEARCH FOR DEVELOPING ALTERNATIVE
COMPOSITE SURFACE MATERIALS**

**A Thesis Submitted to
The Graduate School of Engineering and Sciences of
İzmir Institute of Technology
In Partial Fulfillment of the Requirements for the Degree of
MASTER OF SCIENCE**

In Architecture

**By
D. Turgut ÇIKIŞ**

**June 2007
İZMİR**

We approve the thesis of **Dilaver Turgut ÇIKIŞ**

Date of Signature

.....
Assoc. Prof. Dr. H. Murat GÜNAYDIN
Supervisor
Department of Architecture
İzmir Institute of Technology

21 June 2007

.....
Asst. Prof. Dr. Emre ERGÜL
Department of Architecture
İzmir Institute of Technology

21 June 2007

.....
Asst. Prof. Dr. Ömür SAYGIN
Department of Architecture
İzmir Institute of Technology

21 June 2007

.....
Assoc. Prof. Dr. H. Murat GÜNAYDIN
Head of Department
İzmir Institute of Technology

21 June 2007

.....
Prof. Dr. M. Barış ÖZERDEM
Head of the Graduate School

ACKNOWLEDGEMENTS

Over the past few years I have been privileged to work with and to learn from people, and to all those people I owe a debt I can never repay.

To Assoc. Prof. Dr. Murat Günaydın, I am grateful, firstly for providing me an environment in which I could set my own direction, and secondly for his many contributions to my understanding of research methodology and to this thesis in particular. Assit. Prof. Dr. Emre Ergül, and Assit. Prof. Dr. Ömür Saygın have each contributed to my study through critics and shaped this research in important ways. I would also express my gratitude to Assoc. Prof. Özen Eyüce and Prof. Dr. Ahmet Eyüce for their contribution to my academic studies.

I owe to my special thanks to my wife Şeniz Çıkış for her support, help and patience. I also acknowledge to my daughter Deniz Çıkış for her support and existence. Lastly friends, of course, provided the support network to sustain me throughout my studies.

ABSTRACT

THE EVOLUTION AND CHANGE OF BUILDING FACADES: A RESEARCH FOR DEVELOPING ALTERNATIVE COMPOSITE SURFACE MATERIALS

Cladding of buildings is an important and commonly applied activity area of building sector. As it is known major purpose of cladding is to separate the indoor environment from the outdoors in such a way that indoor environment conditions can be maintained at level suitable for the buildings intended use. Therefore from the functional point of view it can be defined as, the part of the building that is non load bearing exterior wall that must defend the interior spaces against invasion by water, wind, sun, light, heat and cold, and all the other forces of nature. Besides this it must also fulfill the aesthetic, economic and security consideration.

The design of the building façade has become much more complicated with development of new methods of construction, the requirements for a highly controlled interior environments, stress on energy efficiency, advent of materials and new production methods. But it seems that available technologies on ordinary building sector relay on the analog production methods. Analog production process depends on technical drawings and the interpretation of drawings. The human interpretation is the basics of the systems. On the other hand, new design tools that introduced by computer aided design programs proposes new conceptions of space that beyond the limits of Cartesian understanding of form and construction.

It is known that computer aided design and production methods are applied pervasively in numerous different sectors. Articulation of computer aided design and manufacturing processes with digitally driven assemblage methods is an important task that is expected to be solved by the building sector. Building envelope systems as being one of the most important building component from the points of both identity and utility of buildings, is has to be reconsidered as a part of the adaptation of whole construction sector. It is also a measure of responsibility on the part of architects. Besides material design, production processes, and connection details of the components with the other parts of the building are the other important dimensions of the envelope systems.

ÖZET

BİNA CEPHELERİNİN EVRİMİ VE GELİŞİMİ: ALTERNATİF KOMPOZİT CEPHE KAPLAMA MALZEMELERİ GELİŞTİRMEK İÇİN BİR ARAŞTIRMA

Binaların giydirilmesi inşaat sektörü için önemli bir uygulama alanıdır. Bilindiği gibi giydirmenin ana amacı bina içi ortamı dış ortamdan yapının kullanım amacına uygun biçimde ayırmaktır. İşlevsel açıdan bakıldığında, giydirme cepheyi su, rüzgâr, güneş, ışık, sıcaklık ve soğukluk gibi dış etkenlere karşı bina içi ortamı koruyan, taşıyıcı olmayan bina dış kabuğu olarak tanımlamak mümkündür. Bunların yanında, giydirme cephenin estetik, ekonomik ve güvenlik amaçlarına da uygun olması gereklidir

Bina cephe tasarımı yeni inşa yöntemlerinin gelişmesi, enerji tasarrufu baskıları, iç mekândaki koşulların denetimi ve yeni malzemelerin geliştirilmesiyle daha karmaşık bir hal almıştır. Gelişen teknolojilerin inşaat sektöründe analog üretim biçimlerini zorladığı görülmektedir. Analog üretin süreçleri teknik çizim ve çizimlerin yorumlanmasına dayanmaktadır. İnsan yorumu sistemin temelini oluşturmaktadır. Diğer taraftan, bilgisayar destekli tasarım yoluyla sunulan yeni tasarım imkânları kartezyen düzlemin sınırlarının ötesinde tasarım araçlarını sunmaktadır.

Bilgisayar destekli tasarım ve üretim birçok sektörde yaygın olarak kullanılmaktadır. Bilgisayar destekli tasarım ve üretim süreçlerinin sayısal olarak yönetilen süreçlerle üretilmesi yapı sektörünün çözüm bekleyen önemli bir konudur. Bina kimliği ve kullanımının önemli bir bileşeni olan yapı kabuğu sistemi bu süreçlerin uygulanması için önemli bir alandır. Üretim süreçleri, bağlantı detayları, diğer yapı bileşenleriyle ilişkileri, bağlantı detayları gibi aşamalar konunun çözülmesi gereken diğer hususlarıdır.

TABLE OF CONTENTS

LIST OF FIGURES	viii
CHAPTER 1. INTRODUCTION	1
1.1. Problem Definition	2
1.2. Scope of the Study	5
1.3. Method of the Study	6
1.4. Structure of the Study	6
CHAPTER 2. FAÇADE CLADDING SYSTEMS.....	8
2.1. Definitions	8
2.2. Historical Background	10
2.3. Design Principles of Façade Claddings	19
2.3.1. Control of Air Flow.....	20
2.3.2. Control of Heat Flow.....	21
2.3.3. Control over the Entry of Rain and Snow	22
2.3.4. Control of Sunlight and other Form of Radiant Energy.....	24
2.3.5. Control of Vapor Diffusion.....	25
2.3.6. Accommodation of Building Movements	26
2.4. Moods of Assembly of Façade Claddings	28
2.4.1. Stick System.....	29
2.4.1. Unit System.....	31
2.4.3. Unit and Mullion System	33
2.4.4. Panel System	34
2.4.5. Column Cover and Spandrel System	35
2.4.5. Structural Glazing System.....	36
2.5. Materials in Cladding.....	37
2.5.1. Opaque Curtain Walls	37
2.5.1.1. Stone and Artificial Stone.....	38
2.5.1.2. Concrete Panels	39
2.5.1.3. Terra-Cotta Ceramic Panels.....	44
2.5.1.3. Metal Panels	48

2.5.2. Transparent Curtain Walls	51
CHAPTER 3. DESIGN AND CONSTRUCTION WITH DIGITAL TECHNOLOGIES	55
3.1. Digital Applications in Design	55
3.1.1. General Definitions and Functions of Design Tools.....	56
3.1.1.1. Symbolic Design Tools	59
3.1.1.2. Analog Design Tools	61
3.1.1.3. Digital Design Tools.....	62
3.1.1.1.1. Object Based (CAD and CAAD) Programs in Design	63
3.1.1.1.2. Solid Modeling and Animation Programs in Design	64
3.2. Digital Fabrication and Rapid Manufacturing in Construction	67
3.2.1. Digital Fabrication Methods.....	68
3.2.1.1. Cutting Methods (Lateral Countering)	70
3.2.1.2. Subtractive Fabrication.....	71
3.2.1.3. Additive Fabrication	74
3.2.1.4. Formative Fabrication.....	76
3.2.2. Digital Fabrication and Rapid Manufacturing in Construction Sector	76
3.2.2.1. Digital Cladding and Surface Treatments	83
CHAPTER 4. CASE STUDY	88
4.1. Definition of the Selected Project.....	88
4.2. Restrictions and Objective	93
4.3. Development of Cladding Design.....	95
4.3.1. Material and Production Process Selection.....	97
4.3.1.1. Material Selection.....	97
4.3.1.2. Process Design.....	101
4.4. Design	102
4.4.1. Composite Design	102
4.4.2. Moulding Design.....	104

CHAPTER 5. CONCLUSION	106
REFERENCES	107

LIST OF FIGURES

<u>Figure</u>	<u>Page</u>
Figure 2.1. Facade treatment of King’s Collage Chapel	10
Figure 2.2. Treatment of La Sainte Chapel in Paris	11
Figure 2.3. Bess of Harwick Mansion, large window openings from ceiling to floor occupies the function of cladding wall.....	11
Figure 2.4. Masonic temple	13
Figure 2.5. Hallidie Building, 1918.....	14
Figure 2.6. Facade Detail of Hallidie Building	15
Figure 2.7. Empire State Building	16
Figure 2.8. Equitable Building is the first glass and aluminum clad building	17
Figure 2.9. Lever Building	18
Figure 2.10. Facade detail of Seagram Building	18
Figure 2.11. Air flow through the exterior wall is caused by one of the tree forces that create pressure differentials. Air movement only occurs if there is an opening in the wall.....	20
Figure 2.12. Alternative deformation of cladding components depending on building movement	28
Figure 2.13. Schematic drawing of typical version of stick System	29
Figure 2.14. Unit systems Split mullions and tubular transoms with screw	32
Figure 2.15. Unit and mullion system	33
Figure 2.16. Panel system, between floor to floor.....	35
Figure 2.17. Column Cover and Spandrel System	36
Figure 2.18. Concrete panel slab bearing connection detail.....	40
Figure 2.19. Precast concrete panel isolation details.....	41
Figure 2.20. Precast concrete panel with integral thermal insulation.....	42
Figure 2.21. Fabrication of GFRC curtain wall panel.....	45
Figure 2.22. Typical connections of GFRC panels to a steel building frame	44
Figure 2.23. Details of terra-cotta tile cladding.....	46
Figure 2.24. Fabrication and insulation of a brick panel curtain wall.....	47
Figure 2.25. Horizontal and vertical joint between metal panels creates a pressure equalization chamber	49

Figure 2.26. An example of outside glazed stick system	53
Figure 2.27. Vertical joints between Aluminum panel system	54
Figure 3.1. Example of composite curve and similar curve described by using spline geometry (NURBS)	68
Figure 3.2. Frank Gehry, Experience Music Project	71
Figure 3.3. Mock-up process	72
Figure 3.4. Gehry, Dusseldorf Office Building	73
Figure 3.5. Gehry, Conde Nast Cafeteria	74
Figure 3.6. Franken, BMW pavilion	74
Figure 3.7. Structural Frames in Gehry's Experience Music Project.....	78
Figure 3.8. Bilbao Museum, Steel Detailing software	78
Figure 3.9. Franken, BMW pavilion	79
Figure 3.10. Triangular Geometry.....	80
Figure 3.11. Lars Spuybroek, Water pavilion	81
Figure 3.12. Use of ruled surface	81
Figure 3.13. Gehry's Zollhof Towers.....	82
Figure 3.14. Gehry's DG Bank.....	82
Figure 3.15. Kolatan Raybould House Addition.....	84
Figure 3.16. Future System, Nawest Media Center.....	84
Figure 3.17. Le Corbusier, Domino House	85
Figure 3.18. Statue of Liberty.....	85
Figure 3.19. Kolatan, Raybould house	86
Figure 3.20. Foster's Albion Riverside	87
Figure 4.1. Emblem of the building.....	88
Figure 4.2. Perspective view of the building.....	89
Figure 4.3. Rear View	90
Figure 4.4. Site plan.....	90
Figure 4.5. Entrance floor plan.....	91
Figure 4.6. Typical floor plan.....	91
Figure 4.7. Front façade.....	92
Figure 4.8. Partial section.....	92
Figure 4.9. Fixing detail	93
Figure 4.10. Cladding parts	94
Figure 4.11. Cladding parts, inside view	94

Figure 4.12. Fixing system by screwing.....	96
Figure 4.13. Fixing system of the panels by using adhesives	96
Figure 4.14. Another adhesive system	97
Figure 4.15. Honeycomb reinforcement.....	103
Figure 4.16. Hand lay-up methods	104
Figure 4.17. Cnc machine.....	104
Figure 4.18. An open mould example	105

CHAPTER 1

INTRODUCTION

The effect of Industrial Revolution in building construction was so powerful that the built environment totally changed in a short time. Not only the new techniques and new materials but a new social system was determines this change. Mass and mechanized production techniques, fabrication of building materials were the significant faces of a new era in architecture. At the end of the 20th century, information technology and spreading the usage of computers in all sectors creates a new revolution effect in global scale. New apparatus in design and new methods in construction point out new possibilities for built environment. Experimental and unique works in architecture trying to search new possibilities in spatial constructs beyond the Cartesian coordinates by using computer aided design systems are accomplished. Today the digital generative processes are opening up new territories for conceptual, formal and tectonic explorations articulating an architectural morphology focused on the emergent and adaptive properties of form. Complex tectonic and surface which features prominently in contemporary architecture brought to the fore the question of how to produce and construct such complex forms. The answer of this question has come from the other sectors such as aerospace automotive and shipping industries. The utilization of digital production and processes control found in the automotive and aerospace industries forced the construction sector to adapt its labor and working processes. For example, assemblage becomes the major activity of the construction site. Digital technologies also rearranged the relationships between design and production of buildings.

On the other hand, relations and methods of conventional production still continue to exist. Because of this reason practice and production of most of the design fields are still executed by the conventions established by industrial relations. The adaptation of the field of architecture to the newly developing technologies inevitably, brings about some adaptation problems and hybrid technologies. This study that proposes a new kind of cladding system rises on this foundation. The demands of designers who use digital technologies in designing stages are not meet by the existing building sectors. Adaptations of the conventional cladding systems that based on mass

produced, planer elements, to customized and complex building envelope is the major task of the study.

1.1. Problem Definition

Cladding of buildings is an important and commonly applied activity area of building sector. As it is known major purpose of cladding is to separate the indoor environment from the outdoors in such a way that indoor environment conditions can be maintained at level suitable for the buildings intended use. Therefore from the functional point of view it can be defined as, the part of the building that is non load bearing exterior wall that must defend the interior spaces against invasion by water, wind, sun, light, heat and cold, and all the other forces of nature. Besides this it must also fulfill the aesthetic, economic and security considerations (Kolarevic, 2003). Because of these reasons its design is an intricate process that merges the art, science and craft to solve a very long and difficult list of problems. The design of the building façade has become much more complicated with development of new methods of construction, the requirements for a highly controlled interior environments, stress on energy efficiency, advent of materials and new production methods. But it seems that available technologies on ordinary building sector relay on the analog production methods. Analog production process depends on technical drawings and the interpretation of drawings. The human interpretation is the basics of the system. Analog production process which depends on the drawing techniques begins in Renaissance era and spread in industrial revolution is still constitutes the main form of the building construction. On the other hand, new design tools that introduced by computer aided design programs proposes new conceptions of space that beyond the limits of Cartesian understanding of form and construction. Experimental examples of digital architecture are basically produced by conventional methods. Whereas, it is known that computer aided design and production methods are applied pervasively in numerous different sectors. Articulation of computer aided design and manufacturing processes with digitally driven assemblage methods is an important task that is expected to be solved by the building sector. Building envelope systems as being one of the most important building component from the points of both identity and utility of buildings, is has to be

reconsidered as a part of the adaptation of whole construction sector. It is also a measure of responsibility on the part of architects.

The reason of limited use of computer aided manufacturing methods in construction sector comparing with pervasive use in industrial production lies in the fact that building is not a mass production object. Even if some components of them are produced by industrial processes, buildings are principally constructed designs. Today, in spite of marvelous contribution of technology, the act of constructing or building is still close to its departure point. Manufacturing of digital data by the help of digital production processes and assemblage of these components for the realization of construction represents an important transformation in building production. It is necessary to accept or foresee the require amount of time for the realization of transformation in this scale. Governing of digital design and manufacturing methods and their new relationships will probably have an important impact on the total transformation of the built environment. Digital manufacturing and design methods with in this enormous process of transformation will also generate important opportunities for the construction market. In the light of ideas mentioned above, this thesis aims to develop an appropriate cladding system, by evaluating techniques of digitally driven industrial production and considering the adaptation problems with conventional building components, without losing unique characteristics of architectural end product.

Computer aided design has been emerged as a method which provides eases and speeds in drawing and modeling tools. In a short period of time, by the help of the advanced technologies, the promise provided is increased rapidly. These technologies provided to operate with non-Euclidian geometries by using tree dimensional modeling, beyond the limits of conventional drawing techniques. In common practice however, constructions of these buildings that are designed by the aid of digital technologies are realized by ordinary or conventional technologies.

Starting from the post war era, when first exposed for sale in the construction market, industrially produced curtain wall systems have still predominant mood in the sector. Planer cladding techniques such as prefabricated panel production technologies and glass and aluminum curtain wall systems are basically drives from construction methods of the rectilinear design understanding of modernism.

Today double curvature forms of computer aided design methods are produced by the technology transfer from the various fields of engineering as it has previously

been. In the experimental studies, in despite of their disadvantage of expenditure, airship modeling and steel plate processing methods are applied. Another technology transfer field is the naval constructions. Molding methods that are used in construction of the chassis of ships are widely used in these exceptional cases. For example by the help of high competency in workmanship, the unique surface components that forms and cover the structure is produced depending on sequential basis (Zellner 1999).

It seems that cost is the major problem of these applications especially on account of construction sector. For example, formative methods that used in aero-ship or automotive industries become feasible for the reason that the mass production of similar components. Since the subsequent objective of architectural design, without regarding the design tool, is to create unique and contextual end products, it is not possible to apply exactly the same of these manufacturing processes. In fact it can obviously be observed that some building components are produced by using these kinds of technologies. For example advanced digital technologies are applied in the manufacture of sanitary equipments, lighting, and fenestration. But it is also obvious that formation of building envelope is far from being this kind of market commodity. Today industrially produced building envelope systems are carried on by the planer elements and their assemblages. However development of alternative cladding technologies which able to convert data of the digital design processes into manufacturing processes directly is inevitably required. As a result of the developments in the digital technologies, it is possible to predict gradual dominancy of digital data transfer systems over analog data transfer conventions. On the other hand as it has been indicated before, the unique characteristic of architectural product is not convenient as the manufacturing processes of the other sectors especially quantity and cost factors are considered. The fact that, automation is only feasible under mass production conditions of standard components automotive and aero-ship industries are not preferable for the field of architecture. Because of these circumstances, it is rather preferable to adapt construction methods from the shipping industry especially for the molding and production processes of the cladding components.

An important task that is to be considered in manufacturing processes is the design and the selection of material spectrum. Alternatives of materials that are used in conventional cladding applications are required to be developed, considering the performance of the materials used in other sectors. The cost is also important factor in the production of material of building components. In addition to cost factor, endurance

period is another factor for building components comparing with other sectors. That's why construction industry is being an important field of activity of chemical industry. Particularly, petroleum derived polymer materials are used extensively for the purpose of protection and adherence in edifice construction. The design of composite materials which is prepared depending on a specific purpose is an important issue in these kinds of matrix materials. Composite materials that are made of natural aggregates and fibers, and also polymer adherences that bring them together are important subject matter of construction sector. Besides material design, production processes, and connection details of the components with the other parts of the building are the other important dimensions of the envelope systems.

1.2. Scope of the Study

In this study it was aimed to exemplify changing production and manufacturing practices of cladding systems with in the context of the changing dynamics of the construction sector. Cladding and curtain wall technologies were improved after the second half of the 20th. Century, are established some standards and codes. In other words the criteria which is developed for the cladding systems that is freed from building structure and expected to control environmental conditions, were for the controlling of the complicated balance between inside and outside of the buildings (Quirouette 1982). Even if the design and production moods changes, it is expected to maintain existing standards. During the course of transition which complicated inputs of the design can not be succeeded by the use of analog methods, examples that are going beyond the limits of being simple, shelter of the building envelope come in to agenda. Beyond the conventional function of cladding that is defined as to mediate between outdoor and indoor environment, factors such as color, visibility or texture is expected to be controlled.

In spite of all these advanced applications mentioned above, the scope of this study is limited with the search for appropriate alternatives to develop building components with computer aided design data by using computer aided manufacturing processes. It is known that some advanced technology and materials are used in some distinguished example without considering cost criteria. But in common practice new technologies can only accommodated by scrutinizing of cost and available labor skill.

Because of these imperative factors, the scope of the study has broadened as to contain appropriate technology selection and material design.

1.3. Method of the Study

Appropriate computer aided design and manufacturing processes are examined in a selected case. It can be observed that the selected project is not formed by using double curvatures or in other words non-Euclidian geometries. In spite of the possibilities provided by the use of computer, it was previously estimated or planned that the building would be constructed and the data would be transmitted by conventional methods. Today almost every building design or construction should be considered as digital design product since their data is transferred by using computer aided design tools. Besides this fact, it can easily be stated that the use of the computer is rather limited with the drawing and presentation phases of the whole design and construction processes. Even if so, the use of the digital data during the process of computer aided manufacturing is investigated. Following the realization of system and assemblage details and material design of cladding, in the light of the selected project, the performance of the developed building components and adaptability of them within the frame of ordinary building construction sector is discussed.

To reach to this aim it was necessary to make a literature review of both cladding systems which are commonly applied and digital application in architectural practices. Historical frame is limited in the collection of data for the facade cladding techniques and criteria which relevant and valid. It is necessary to not that literature review and classification of cladding methods that industrially produced since the beginning of the 1950 has given weight in this thesis. Divergence of facade from the structure and changing design criteria are accepted as the reference points of the previously mentioned cladding systems.

1.4. Structure of the Study

This thesis is an inquiry into the adaptation of the digital technologies in cladding systems of ordinary building sector. As it is known, advanced cladding applications are widely applied all around the world. Whereas, cladding applications are

excessively expensive and requires high degree of competency in digitally designed buildings. In other words, it investigates the transition from analogue to digital or from orthographic to numeric way of production in cladding, in order to study the effects of this transition on the changing relations between design and production.

Considering, this aim of the study it can be extracted that the main body of the thesis must cover these two major aspects of the topic: cladding systems and digital design and construction matters. Besides this it is required to propose a system that can be adapted to the existing manufacture systems of the construction sector. That's why the thesis consists of five chapters. Following the 'Introduction' in Chapter I, Chapter II dwells on commonly applied cladding systems. This chapter titled as 'Facade Cladding Systems' covers general definitions and terminology of the issue. Besides this, historical background is summarized starting from the pre-industrial era, to today's advanced systems. Chapter also covers various technical aspects of the cladding systems. This part of the second chapter concentrates on design principles, types, moods of assembly, and materials. Further more, these classifications has given the researcher the opportunity to clarify the terminology, technique and method confusion in existing literature of claddings.

Chapter III titled as 'Design and Construction with Digital Technologies' is occupied with the changing professional practices by the introduction of the digital technologies both in design and construction fields. The chapter starts with digital applications in design introducing the essential function of design tools. Besides this existing computer programs and their working principles are introduced. Following this part, digital applications in manufacturing of different sectors is handled. Digital fabrication methods classified as cutting, subtractive, additive, and formative is explicated. Digital fabrication and rapid manufacturing in construction sector is evaluated following the explanation of the manufacturing systems. At the end of the chapter III, digital applications in cladding of buildings are categorized and exemplified. According to this classification digitally driven cladding applications are examined under the titles of, off setting, unifying, and conventional methods.

Depending on the information given on the first three chapters, chapter IV is allocated to the case study. In this chapter, it was aimed to develop a digitally driven cladding system which was appropriate to the existing organization system of the construction sector. The chapter includes the definition of the selected projects, restrictions and objectives, development of cladding design, material and production process selection design, and analysis of findings.

CHAPTER 2

FAÇADE CLADDING SYSTEMS

2.1. Definitions

Creating an enclosure to mediate the environment is one of the basic needs of human being. Protection against excessive climatic conditions, natural disasters or other humans or animals are the primary incentive of this need. Starting from this point on, it can be stated that, the major purpose of cladding is to separate the indoor environment from the outdoors in such a way that indoor environment conditions can be maintained at level suitable for the buildings intended use. Therefore from the functional point of view it can be defined as, the part of the building that is non load bearing exterior wall that must defend the interior spaces against invasion by water, wind, sun, light, heat and cold, and all the other forces of nature. Besides this it must also fulfill the aesthetic, economic and security considerations. Because of these reasons its design is an intricate process that merges the art, science and craft to solve a very long and difficult list of problems. The design of the building façade has become much more complicated with development of new methods of construction, the requirements for a highly controlled interior environments, stress on energy efficiency, advent of materials and new production methods. As a measure of responsibility on the part of architects the envelope needs to be well designed.

The terms, cladding and curtain wall are sometimes confusing in the technical literature. Even in technical dictionaries the terms cladding and curtain wall are defined with similar properties i.e. non- load bearing wall of a skeleton frame (Osterle 2003). made a distinction between solid and transparent facades. According to them, the non-transparent area of the façade will be thermally insulated and then rendered or finished with modern cladding systems. The cladding with a ventilated cavity to the rear is fixed with carcass structure. Stone is one of the cladding materials used for these non – transparent facades. According to the definition of curtain wall by Osterle, the curtain wall is separated from the structure and its structure, suspended between the floors of the buildings and façade elements can be prefabricated. The type of infill material is not important in most of the definitions (Schaupp 1967). explained the development of

stone facades with stone adhered to the back structure to ventilated walls and he named this ventilated stone wall as a curtain wall, but this should be called as stone cladding since there is a direct connection of the stone panels to the backup wall (Musağaoğlu 2005).

But in most common sense the cladding wall is described as “the finish covering of an exterior wall of frame building; the siding may be cladding material such as wood, aluminum or asbestos cement (but not masonry) applied vertically or horizontally” in the dictionary of architecture and construction, prepared by Harris (Harris 1993). According to Linda Brock however, the term cladding denotes the visible materials on the exterior of the wall. Cladding act as the primary weather barrier, and as such they are sometimes called a rain screen. Some claddings such as insulated glass units perform all of the walls functions (Brock 2005).

Allen also unites the concepts of curtain walls and cladding walls. According to her, the name “curtain wall” derives from the idea that the wall is thin and “hangs” like a curtain on the structural frame (Most of curtain wall panels do not actually hang in tension from the frame, but supported from the bottom at each floor level) The earliest curtain walls were constructed of masonry The principle advantage of the curtain wall is that because it bears no vertical load, it can be thin and light in weight regardless of the height of the building, as compared to a masonry load bearing wall, which may become prohibitively thick and weighty at the base of a very tall building (Allen 2004).

But most of the definition is made in relations to the structure of the building. For example; according to Ochshorn, the curtain wall is defined in terms of its functional relationship to the building's structure. It then refers to the cladding, or enclosure, of a building as something both separate from and attached to the building's skeletal framework (Ochshorn 2003). Where load bearing walls provide both structure and enclosure, there can be no curtain wall. But difficulties emerge within this definition when the question of "infill" is considered: are conventional windows (or other infill material), when fixed inside the boundaries of a structural frame, considered to represent curtain wall construction? Such construction is certainly "attached" to the structural frame, but not exactly "hanging" from it. When is a window just a window within a frame, and when does it transform into a curtain wall? The answer may have more to do with one's aesthetic bias than with the actual functional relationship between cladding and structure. Another and more comprehensive definition of the curtain wall is made by Quirouette; a curtain wall system is a lightweight exterior cladding which is

hung on the building structure, usually from floor to floor. It can provide a variety of exterior appearances but characterized by narrowly spaced vertical and horizontal caps with glass or metal infill panels. These systems provide a finished exterior appearance and most often a semi-finished interior as well (Quirouette 1982). They are also designed to accommodate structural deflections, control wind-driven rain and leakage, minimize the effects of solar radiation and provide for maintenance-free long term performance. Most of today's metal curtain wall systems are constructed of lightweight aluminum, although some may be of steel.

2.2. Historical Background

Even walls present in building traditions since the beginning of human existence, the intention of creating large openings on it was first seen in the gothic architecture. But the concept of fully glazed wall developed fitfully soon after this period. Therefore it was an architectural idea only awaiting necessary technology to become a reality. According to the architectural historians who have studied on this field, Bath Abbey and King's College Chapel in Britain and La Sainte Chapel in Paris are the first examples of this kind of façade treatments, in Figures 2.1. and 2.2.



Figure 2.1. Facade treatment of King's College Chapel
(Source: Quirouette 1982)



Figure 2.2. Treatment of La Sainte Chapel in Paris
(Source: Quirouette 1982)

In tree of these buildings, the windows were enlarged to the point of forming virtually the entire wall that was not needed for roof support. During the sixteenth century of England, large areas of glass brought into the design concepts, especially in mansions. Bess of Hardwick House is one of the most well-known examples of this attitude. The use of large windows in this building is appropriate to the logic of cladding walls. This building is one of the earliest examples of the curtain walls.



Figure 2.3. Bess of Harwick Mansion, large window openings from ceiling to floor occupies the function of cladding wall (Source: Quirouette 1982).

Because of the use of classical canons in Renaissance Architecture, large façade openings precluded. The need for this kind of openings comes out again towards the beginning of the nineteenth century. With the development of steel frame structures, potential of combining iron and glass were discovered. Especially in building types such as; exhibition halls, railway stations, greenhouses, pavilions experimental applications were realized. The railroads and their civil structures quickly escalated iron and steel capability. When directly applied to buildings, the composite metal and masonry construction allowed more height with a more open bottom floor. These materials were manufactured and connected easier than masonry and stone alone.

More expedient to construct, metal reinforcing strength reduced the masonry mass with fast methods and less labor. The first adaptations of cast iron were actually as storefront. But changed a frame, the metal skeleton could become structurally independent of skin. Beyond simply applying ornaments to the façade, efforts then slowly separated the skin as a system from the buildings structural frame (Lewis 1995).

Multistory framing systems originated in England in 1792. William Strut's Calico Mill used internal wrought iron posts instead of brick piers. By 1844, refinements replaced the traditional load bearing masonry wall with thin infill behind its iron structure in the Portsmouth Royal Navy Dockyard. In the design of a factory building in New York, James Bogardus, introduced bolted connections to the iron frame that had sufficient stiffness to omit bracing infill walls and cross-bracing. It was clad in glass. After then, in 1851 Joseph Paxton glorified the glazing applications (Lewis 1995).

When large glazed walls came in to existence in multistory high rise buildings, the problem of fire proofing also emerged. The applications of glass curtain walls can be widely seen in Chicago and New York's skyscrapers starting from the middle of nineteenth century. Masonry fronts fell from favor to iron fronts through the 1850's American cities. Susceptibility fire kept them from being universally popular. Chicago's great fire reined buildings with unprotected iron frames, and ended unprotected construction. Catastrophic failures caused codes to require proper resistance. This motivated the ingenuity to encase the frames in masonry, whose structures survived the fires. (Lewis 1995). Solving the fire proofing problem required the fireproofing to be supported directly on the building frame. Because of this reason masonry reappears. In this recurrence, masonry was adapted from being load bearing to being hanged on the frame. Some new systems such as interlocking clay tile to encase framing members are developed for the protection of the main structure. Another system, a wrapping system

was developed by Chicago architect Peter Wight and terracotta producer Sanford Levis in 1874 with a patent. This new technique reverses the previous role of metal and masonry and oriented the mind set towards full masonry separation at the building's exterior wall. Masonry- supporting self angles first appeared in Le Roy Buffington's 1880 proposed clouds scrapers using Gustav Eiffel's riveted connections (Lewis 1995). The concept was realized by Burnham and Root's 1890 twenty-one storey Masonic Temple in Chicago. Masonic Temple that is generally accepted as the first application of the fully masonry curtain wall can be seen in the



Figure 2.4. Masonic temple
(Source: Lewis 1995)

From this point onwards, architects experimented with different cladding materials. At the first years of curtain wall applications alongside with the stone one of the most preferred materials was terracotta stone. Terracotta stone were speared because of its light weight, plastic and aesthetic qualities and also fire resistance. But it is quickly noticed that because of its porous surface and irregular glazing quality weathered poorly though damaged easily, and was difficult to repair. Daily and seasonal heat differences cracked stalled the panels. Water leaking disintegrated anchor straps, corroded supported steel, and split the man made stone faces.

Literature of architecture assigns, Hallidie building (Figure 2.5., 2.6.) as the first pure application of curtain was. This seven-storey building was constructed in 1918 and designed by James Polk. The suspended glass system was cantilevered from floor to



Figure 2.5. Hallidie Building, 1918
(Source: Lewis 1995)

The distance between columns and the suspended, multifloor glass wall was about 1meter. Narrowing to a mere 75mm. at the glass skin, the cantilevered floor also provided a fire break (Brock 2005). According to Kenneth Frampton, Polk's decision to break away from the masonry of Richardsonian architecture was influenced by a desire for natural light, a limited budget and a need to facilitate erection of the building (Wigginton, 2002).



Figure 2.6. Facade Detail of Hallidie Building
(Source: Brock 2005)

Another big step was taken in Empire State Building by the architects Shreve, Lamb and Harmon in 1929 (Figure 2.7.) in this building, aluminum spandrels which can be seen in Figure 2.7, were introduced for the first time. A year later Holabird and Rood finished a building for the Smith Corporation of Milwaukee which was use largely of glass and heavy aluminum extrusions. In Britain, William Crabtree's building for Peter Jones in Sloan Square, London, in the late 1930s had notably elegant curtain wall (Allen 1997).



Figure 2.7. Empire State Building
(Source: Allen 1997)

Starting at the end of the Second World War, the 20th-century's ubiquitous metal and glass curtain wall systems (repetitive grids of extruded aluminum mullions and horizontal rails, fastened to a building's structural skeleton, and supporting panels of glass or metal) increasingly began to appear on commercial and institutional buildings. The newly-invented float process made large areas of glass even more feasible beginning in the 1950s.

Other panelized curtain wall systems also appeared as cladding options: these included composite metal panels containing lightweight cores of honeycombed material or foamed plastic insulation sandwiched between two layers of thin sheet metal (aluminum or steel); precast concrete panels, custom-designed for each job, but still manufactured within a rationalized, systematic production setting; and thin stone veneer panels factory-cut to a thickness as little as one 2,5 cm. then attached to the building's structure using proprietary metal clips and anchors (Ochshorn 2003). Even traditional brick and stucco became integrated into manufactured curtain wall systems: brick as part of layered cavity wall systems; stucco, most commonly in the form of exterior insulation and finish systems (E.I.F.S.), consisting of thin polymer-based plaster lamina applied with fiberglass reinforcing mesh to a surface of rigid foam insulation.

For example, after 1945 a major advance was made by Pietro Beluschi in his Equitable Building (Figure 2.8.), in Portland. This was the first large building to be

totally sheathed in glass and aluminum the first to be fully air conditioned and double glazed and first to have traveling crane for window washing (Allen 1997).

Gordon Bunshaft of Skidmore Owings and Merrill, soon to be followed by Harrison Abramowitz's Building for the United Nations and the Seagram Building in Figure 2.10 by Mies van der Rohe and Phillip Johnson. Development of extruded aluminum frames began in the 1950's.

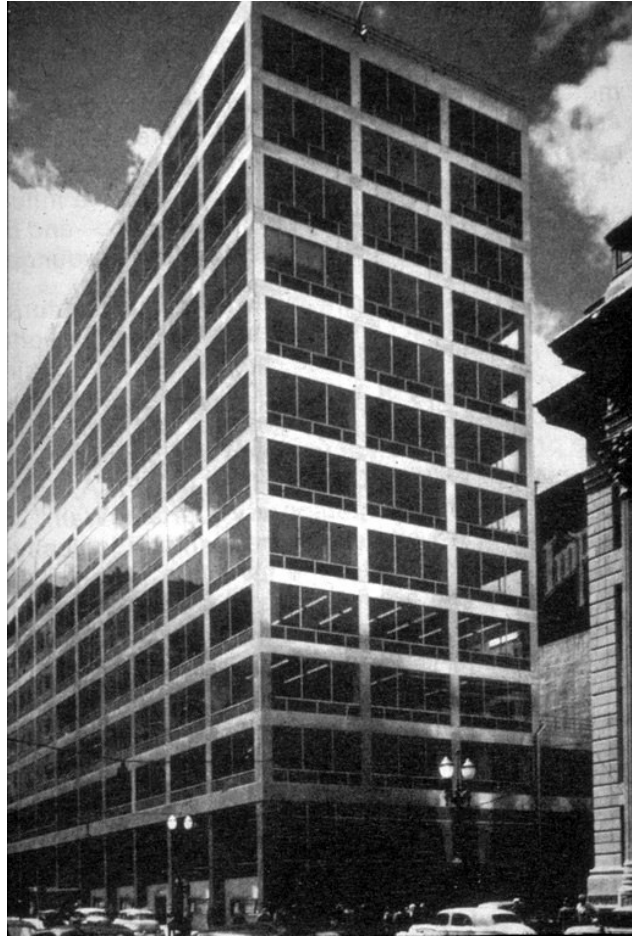

Figure 2.8. Equitable Building is the first glass and aluminum clad building
(Source: Allen 1997)



Figure 2.9. Lever Building
(Source: Allen 1997)

At about the same time, came the Lever Building in New York in Figure 2.9 by Bolting glass together with small metal patches, a system called structural glass was introduced in 1960's. But the greatest change in the last fifty years took place in glazing technology. Before the commercial use of float glass, it was pricey material if not marred by imperfection (Allen 1997).

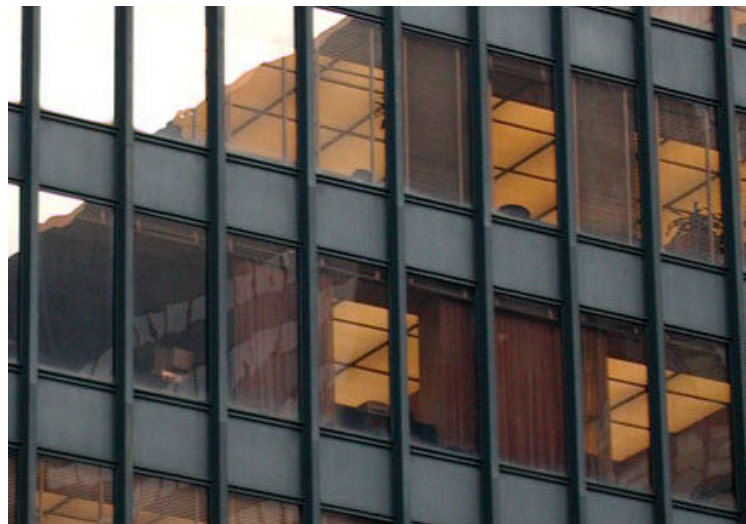

Figure 2.10. Facade detail of Seagram Building
(Source: Allen 1997)

Today the curtain wall application realized all over the world. Especially glass curtain walls are ubiquitous on office towers. Potential of this system is developing systematically, for example glass cubes, curved glass, floating and flying forms of transparent, reflective, translucent, colored and patterned glass are becoming more common place. On the other hand new materials are developed by the market, such as composites, artificial stones or PVC based materials. The design of the enclosure has become much more complicated with the advent of modern synthetic and composite materials, sophisticated new fabrication systems new methods of constructions, new trends towards lighter and economical skins, stress on energy efficiency and the requirement of highly controlled interior environment (Brock, 2005). Besides glass, metal, composites even stone claddings are part of digital architecture that based on non Euclidian geometries. It is clear that the use of the cladding systems are not limited with the conversional construction restrictions.

2.3. Design Principles of Façade Claddings

Primary Functions of Cladding:

As it is known the most important purpose of cladding is the separation of the indoor environment of a building from the outdoor. Because of this purpose the building enclosure may be broadly defined as a set of interconnecting elements which separate the outside from the inside. These elements would include exterior walls, a roof other components such as windows and doors, and sometimes exposed floors. The function of a building enclosure is to control the penetration of snow, wind, rain and sun to the inside and to contain the desired indoor climate.

The enclosure must meet many individual requirements but for the purpose of this thesis they are generally limited to the following six as proposed by Quirouette and Allen:

1. Control of Air Flow,
2. Control of Heat Flow,
3. Control over the Entry of Rain and Snow,
4. Control of Sunlight and other Form of Radiant Energy,
5. Control of Water Vapor Diffusion,
6. Accommodation of Building Movements.

2.3.1. Control of Air Flow:

Air currents carry water, water vapor and conditioned air (heated and cooled); pollutants and sounds are transported by air. However the movement of air through a wall has positive as well as detrimental effects. Air circulation is essential to our well being that's why buildings are required by code to bring in fresh air. On the other hand, as higher levels of insulation were added to walls condensation problems starts to occur.

Air pressure differentials produce air currents; the well known is wind. The wind applies a positive pressure on the windward side, resulting in infiltration of the interior. Gusting winds cause higher cyclic pressures. The natural phenomenon caused by warm air rising in building is called chimney or stack effect. In heating climates, interior pressure increases at the upper levels as the warm air rises, causing cooling air to be drawn in at the lower levels. In cooling climates, with the air conditioned interiors, this effect is reversed. Positive and negative pressures are also created by mechanical ventilation systems (Brock 2005). It is generally assumed that negative pressure is desired in heating climate and positive pressure in cooling climates.

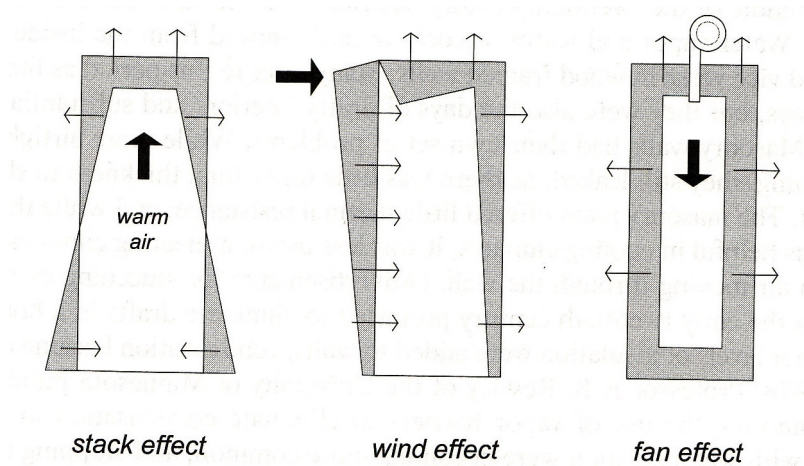

Figure 2.11. Air flow through the exterior wall is caused by one of the three forces that create pressure differentials. Air movement only occurs if there is an opening in the wall (Source: Brock 2005).

The cladding must prevent the unintended air flow between the indoor and the outdoor environment. It must also regulate the air velocities within the building. The requirement for air tightness and consequently air leakage control is met by most curtain wall systems because the air barrier of the wall is inherited in the structural properties of

glass and aluminum or steel tubes that comprise the system (Quirouette 1982). But in some cladding applications that is made of composites, stone or artificial stone, air leakage problem can be seen. Smaller air leakages are harmful because they waste the conditioned air, carry water through the wall, and allow noise to penetrate the building from outside. Sealants, gaskets, whether strips and air barrier membranes of various types are all used to prevent air leakage through cladding (Allen 2004). The continuity of the air barrier is achieved by the continuity of the glass panel through the air seal at the shoulder flanges of the tubular mullion, and through the aluminum section to the other flange surface. The air seal between the lower shoulder flange of the curtain wall mullion and the metal pan of the spandrel panel provides continuity of air tightness to the air barrier metal pan and on to the next mullion connection. Such assemblies are regularly tested using air pressure to determine the structural properties of the glass, metal, and seals and to determine the equivalent leakage area (RLA) that remains. In addition, the Architectural Aluminum Manufacturers Association imposes upon its members many other requirements including a specification that the system must not leak more than 30 L/s per m² of wall at a pressure difference equivalent to a 40 km/h wind (Quirouette 1982).

2.3.2. Control of Heat Flow

The transfer of heat, whether from the hot exterior environment to air-conditioned interior or from a heated space to the cold outdoors, occurs by convection, conduction or radiation. There are different mechanisms for controlling of each kind of heat transfer. Air flow, initiated from air pressure differences causes the loss of conditioned air either heated or cooled (Allen 2004).

The control of heat flow is generally achieved through the use of insulation. Although it is not apparent from the exterior, the curtain wall system uses considerable insulation usually behind spandrel glass or any opaque panels. Because of the materials used in the structure, i.e., glass and metal, which are highly conductive, the system must also contend with potential condensation on the interior surfaces. To curtail this effect, most curtain wall systems incorporate two distinct features: first, a sealed double glazed window or an insulated metal pan and second, a thermally broken mullion, usually with a PVC plastic insert and more recently, a foamed-in-place polyurethane connection. A

sealed double glazed window unit can accommodate an indoor humidity up to about 35 % at an outdoor temperature of -25 C with little condensation appearing on the glass, Similarly, the thermal break in the aluminum at steel mullion ensures that the surface temperature of the structural mullion will remain well above the dew point temperature of the air for most building types, except for high humidity indoor environments such as in swimming pools or computer centers. The thermal break also ensures that the structural mullion is thermally stable, that is, not subject to extremes of expansion and contraction.

One of the roles of the cladding wall is the regulation of radiant heat flow from the sun. Interior surfaces of building should not get to a state of radiant discomfort. According to Allen; a very cold interior surfaces will make people chilly when they are near the wall even if the air in the building is warm to a comfortable level. A hot interior surface or direct sun light in summer can cause over heating the body despite the coolness of the interior air. These kinds of problem can be solved by using external sun shading devices, adequate thermal insulation and thermal breaks, and appropriate selection of glass. He also states that the cladding of building must resist the conduction of heat into and out of the building. This requires not merely a satisfactory overall resistance of the wall to a passage of heat, but the avoidance of thermal bridges, wall components such as metal framing members that are highly conductive of heat and therefore likely to cause localized condensation on interior surfaces. Thermal insulation, appropriate glazing, and thermal breaks are used to control heat conduction through cladding (Iano 2004).

2.3.3. Control over the Entry of Rain and Snow

Water has harmful effects on materials. For example wood, it rots oxidize metal, it provides a medium for mold and mildew. Some wet building materials or components do not function properly. Besides these, water causes swelling and expansion of some materials and can transport harmful substances or pollutants. It also dissolves the salt in side of the material. Continual freezing and thawing of wet materials adds additional forces. As it is known water expands its volume 4% as it freezes.

Water can enter a wall from rain or snow or ice melt. Improperly adjusted sprinkler heads that direct water to the exterior wall and poorly functioning or designed

gutter systems and scuppers are other forces of water entry. Building envelope, because of its form or articulation system can help or hinder the control of water, flow down the surface of the exterior finishing material. There are other reasons of penetration of water through the wall. For example air pressure differences and capillary suction across the wall can draw water through the wall. Condensation of vapor from interior or exterior sources produces water. Wet construction applications such as pouring concrete floor toppings, dry walling, and some sprayed on- on insulation such as cellulose add moisture to a wall (Iano 2004).

One of the major functions of building claddings is to prevent the water entry in to the inside of building. Water in the form of snow, rain and ice is often driven by wind and can penetrate in side of the cladding or wall not just in a downward direction but in every direction, even upward. As the wind blow, it causes the raise of air pressures and velocities. Water penetration problems are much more acute in high rise buildings. Because wind velocities are comparatively high at altitudes than at ground levels, it is required to drain a huge amount of water from the windward façade of tall buildings during a heavy rain storm. During this kind of storms water pushed by winds tends to accumulate in crevices and against projecting mullions, where it will rapidly penetrate the smallest crack or hole and enter the building.

To control rain penetration through exterior walls the conventional approach is to seal the exterior façade of the building. However, experience has shown that it is unreasonable to expect perfect sealing of a façade; most sealing strategies require continuous attention and maintenance. Studies of the rain penetration problem have revealed a better solution than the façade sealing approach. If the air that leaks in and through cracks and crevices of a façade during a rain storm were limited or stopped, most of the water impinging on the façade would migrate straight down the surface and little would penetrate the wall. This is the essence of the "Rain Screen" principle. If an air tight element is positioned behind a façade, the cavity formed between the exterior cladding and the airtight element may reach the same air pressure level as is exerted on the cladding surface, thus removing the force which causes air to flow through any façade opening. The "Rain Screen Wall" is therefore characterized by a cavity behind the exterior surface that is connected to the exterior but sealed tightly or as tightly as reasonably possible, to the interior. The inner surface of the chamber is usually referred to as the air barrier of the wall.

In most curtain wall systems the joint between the infill panel (i.e., window or spandrel panel) and the structural mullion is usually designed to be part of a rain screen system.

It comprises a pressure-equalized cavity, connected to the exterior by the drain holes in

The exterior caps, and a pressure equalized rain deflector seal between the outside surface of the glass and the mullion cap. The chamber portion of the cavity is composed of the air seals connecting the inside face of the window glass and the spandrel panel metal pan, to the shoulder flanges of the structural mullion and other parts of the structural section. Thus the set of elements comprising the window glass, the air seals, and the aluminum section and metal pan perform the air barrier function for this wall assembly. This design configuration for curtain wall sections has proven successful and has become widely accepted (Quirouette 1982).

2.3.4. Control of Sunlight and other Form of Radiant Energy

Solar radiation falling on building surfaces may have two distinct effects: the first is to cause a significant change in temperature of the façade elements and the second is the slow but destructive effect of ultraviolet radiation impinging on all materials, particularly organic. On curtain wall systems the most important concerns with solar radiation have been the thermal expansion and contraction of curtain wall components, in particular those forming the outside cladding, and the effects of solar radiation on the glazing elements. A warping of glass occurs due to differences in temperature between the inner and outer panes, while pumping results from expansion and contraction of the air in the cavity of the sealed units. Daily and seasonal temperature differences can also cause this effect. The action of the window (thermal pumping) is particularly stressing to the inner air seal; however, serrated edges or recessed flanges keep the seals from pumping out. Most of the ultraviolet-sensitive materials in curtain wall systems are located in the pocket and cavity areas of the joints and are partly shaded by metallic and glass components (Quirouette 1982).

On the other hand, cladding of a building is expected to control the passage of light, especially the sun light. Sunlight is useful for illumination but is undesirable if it causes to glare within a building. Sunlight includes destructive ultraviolet wavelengths

that must be kept off human skin and away from interior materials that will fade or disintegrate. Windows should be placed and proportioned with these considerations in mind. Cladding systems sometimes include external shading devices to keep light and solar heat away from windows. The glasses in windows or glass panels in cladding are often selected to control light and heat transmission from the building openings.

2.3.5. Control of Vapor Diffusion

Vapor diffusion is hard issue to solve. The direction of this movement may change from season to season. Human occupation is another factor that affects the amount of vapor. This flow, created by vapor pressure differentials, moves vapor through very small pores in the components by the mechanism of diffusion. This is also depended on both the air temperature and concentration of water vapor in the air. Vapor retarders prevent the vapor from diffusing the cooler parts of the wall where it may condense. They do not necessarily stop the transmission of vapor by air leakage. Excessive humidity can damage some building components. As the amount of vapor increases the vapor drive increases along with the condensation risk.

Understanding the direction of vapor drive is critical in cladding system. The cladding of building must retard the passage of water vapor. In the heat of the summer or cold of the winter, vapor moving through a wall assembly and cause problem of staining lost insulating value and corrosion. The cladding must be constructed with adequate levels of thermal insulation, suitable vapor retarders, and sealed seams, cracks and holes to prevent condensation of moisture. The migration of water vapor through an assembly of materials is not a serious problem in itself, provided it does not condense to liquid form in the material or wall. If water vapor is likely to condense in a wall, the principal defense is to restrain its migration by using, a "vapor barrier" with a high water vapor flow resistance, positioned on the warm side of the insulation material or wall assembly. Common vapor retarders include polyethylene and vapor resistant paints. Components less likely to be identified as vapor retarders include some insulations, peel-and-stick, foils, paints, interior finishes, metal or vinyl sidings, and exterior sheathing.

The migration of water vapor through a curtain wall assembly is checked by the vapor barrier qualities of the glass and aluminum, as these materials have near perfect

vapor flow resistance for all practical purposes. Thus the inner pane of the sealed double glazed unit and the aluminum or steel inside surfaces of the mullion provide the necessary water vapor diffusion control, sealants also contribute to the continuity of the vapor barrier. The migration of water vapor through a curtain wall assembly is checked by the vapor barrier qualities of the glass and aluminum, as these materials have near perfect vapor flow resistance for all practical purposes. Thus the inner pane of the sealed double glazed unit and the aluminum or steel inside surfaces of the mullion provide the necessary water vapor diffusion control, sealants also contribute to the continuity of the vapor barrier.

2.3.6. Accommodation of Building Movements

Movements of the structural elements of a building must be determined prior to the design of an exterior wall system. Movements may be grouped into three types:

- a. Live load deflections due to occupancy loads, earthquake or peak wind loads on the building façade, and dead load deflections of the building structure
- b. Expansion and contraction of materials as a result of temperature, radiation and sometimes hygroscopic loading
- c. Slow but inexorable movements due to gradual deformation such as creep in concrete, foundation settlement, etc.

As the buildings move, the structure and components of the exterior wall expand and contract, shrink and swell, exacerbated by climate and time. Wind and earthquakes induce lateral forces to the buildings. Aesthetic, insulation and water proofing capacity of cladding system is considered as the most critical functions of building cladding systems. Resistance of it against lateral forces is often neglected. Cladding panels attached to the frame or to furring channel may easily resist to positive wind pressure; but negative pressure can suck these materials off the building. The attachment of cladding must be designed to resist to the pressure from both direction. Pullout loads must be considered in detailing of claddings. A heavy cladding, in combination with a drainage cavity substantially complicates the anchorage. For example in brick veneers; lateral loads are transferred to a back up wall with frequently spaced steel anchor ties that span a wide cavity. The ties must be stiff and strong enough to transfer the positive

loads, while the fasteners that attached to the anchor have to withstand pullout loads from what is often the flange of a light gauged metal stud.

Lateral loads must be transferred to the structural frame of buildings. Backup walls for the cladding must be able to transfer this load to the steel or concrete frame. It is also critical that the stiffness of the backup wall is considered and the differential movement between the backup wall and the structure accommodated. Connections and backup walls are designed by engineers.

According to Brock, earthquakes can have two separate effects on cladding. Heavy cladding must resist to inertia forces which are similar to forces created by wind. Earthquake also can cause forces on the building structure that can induce horizontal forces, creating what is called story drift. Whether it is a glass curtain wall or anchored brick veneer, vertical expansion joints are required to take up this in plane racking movement. The width of these joints is usually greater than that required for expansion. It should be noted that unlike wind, seismic forces do not respect the boundaries of outside and inside (Brock 2005).

Besides the movement of building, under lateral loads named as earthquake and wind forces, other building movements must be taken in to account. For example foundations of building may settle unevenly, causing distortions of the frame. Gravity forces shorten columns and cause beams and girders to which cladding is attached to sag slightly. Wind and earthquake forces push laterally on building frames and wrack panels attached to the faces. Long-term creep causes significant shortening of concrete columns and sagging of concrete beams and slabs during the first year or two of a building's life.

If building movements from temperature differences, moisture differences, structural stress, and creep are allowed to be transmitted between the structural frame and the cladding, unexpected things may happen. Cladding components may be subjected to forces for which they were not designed, which can result in broken glass, buckled cladding sealant failures, and broken cladding attachments (Figure 2.12.)

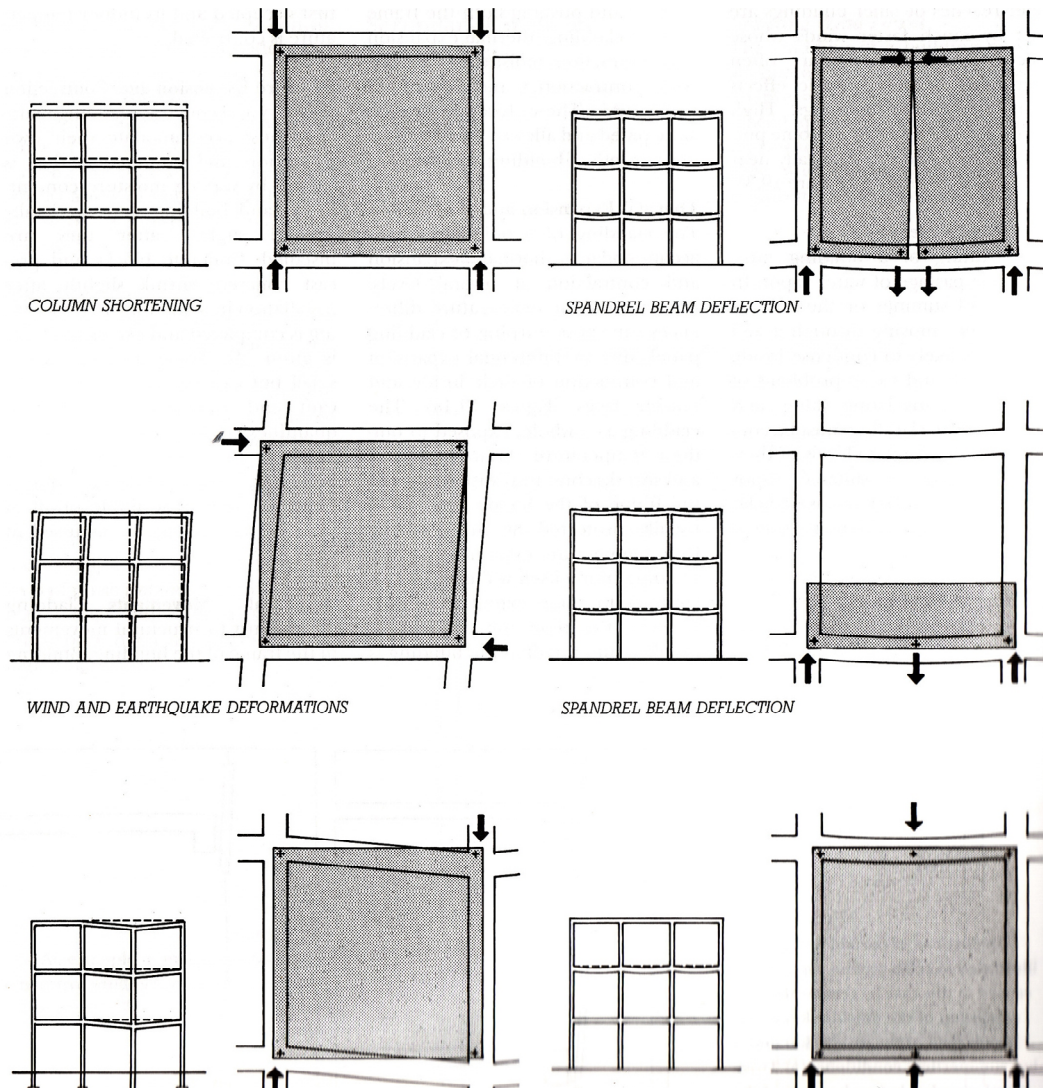

Figure 2.12. Alternative deformation of cladding components depending on building movement (Source: Brock 2005).

2.4. Moods of Assembly of Façade Claddings

Wall cladding systems can be classified according to their mood of assembly at the time of installation on the building. There are six different types of assemblage as similarly classified by Allen, Quirouette or Ochshorn:

1. Stick System
2. Unit System
3. Unit and Mullion System
4. Panel System
5. Column Cover and Spandrel System
6. Structural Glazing System

2.4.1. Stick System

Most of the cladding walls are furnished by using stick systems. This system is also the oldest curtain wall system... It is a cladding and exterior wall system which is hung on the building structure from floor to floor. It is assembled from various components to include steel or aluminum anchors, mullions (vertical tubes), rails (horizontal mullions), vision glass, spandrel glass, insulation and metal back pans (Figure 2.13.). In addition, there are various hardware components to include anchors, aluminum connectors, setting blocks, corner blocks, pressure plates, caps, gaskets and sealants.

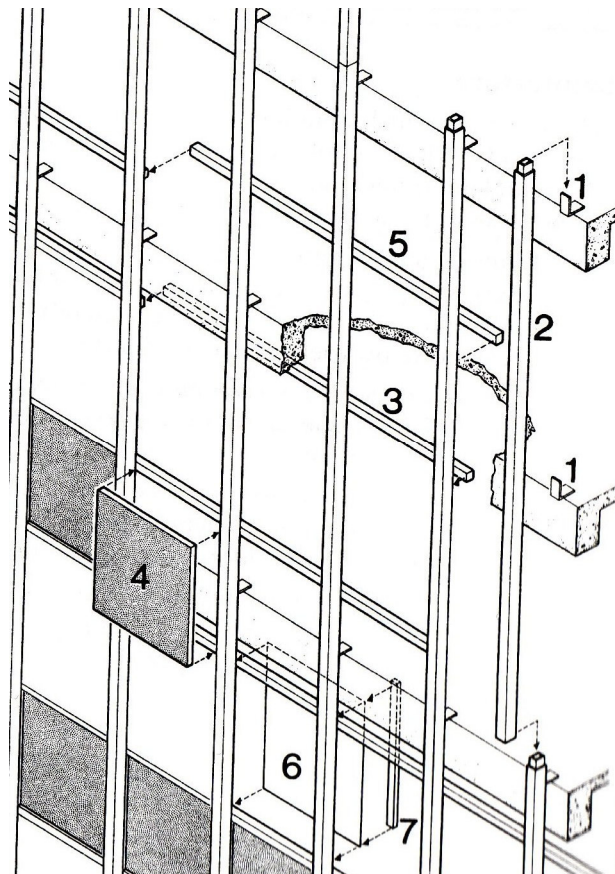

Figure 2.13. Schematic drawing of typical version of stick System
(Source: Brock 2005).

The stick built system is installed by hanging the vertical mullion from a floor edge with a steel angle, while sliding the lower end of the vertical mullion over an insert anchor in the vertical mullion attached below. Vertical mullions are spaced from 1.25

meters to about 1.85 meters depending on the spacing of columns, the wind load, and the desired appearance of the facades (see Fig. below). The joint between the vertical mullions is also an expansion joint for the floor-to-floor live load deflections, any concrete structure creep movements as well as a thermal expansion joint for curtain wall components. These joints must be designed on a job-by-job basis. The rails (horizontal mullions) are then attached to the vertical mullions to create frame openings, one frame opening for the vision area to receive an insulating glass unit (IGU) and one frame opening for the spandrel area) to receive the spandrel panel cover (to hide the floor edge, perimeter heating equipment and ceiling plenum areas).

Vision IGUs are installed in the frame openings between floors. They are always placed in the frame opening on two setting blocks (usually silicone, EPDM or neoprene) spaced about 1/4 of the rail span from each end. The IGU may be air sealed on the inside to the shoulders of the aluminum frame with a gasket (dry seal) or a preshimmed tape and sealant (wet seal). For practical reasons of IGU installation, the glazing method of choice is a dry gasket inside and a wet seal outside. For performance and durability of the IGU, the glazing method of choice would be a wet seal inside and a dry gasket outside. Some systems use a dry/dry glazing method. In the final stage of installation of a glass and aluminum curtain wall, the IGUs and spandrel covers are permanently held in place with full length pressure plates and aluminum snap caps.

The spandrel areas are usually enclosed with a metal back pan (air and vapor barrier), with high density glass fibers or mineral fiber insulation within the back pan. The back pan is then fastened and sealed to the aluminum frame. The spandrel glass is usually monolithic heat strengthened glass with a colored coating (frit) and polyester film to opacity the spandrel glass and to closely approximate the color or tint of the vision units. The spandrel covers may also be aluminum, stainless steel or copper panels. In the last few decades, granite panels as well as sealed units have been installed in the spandrel areas of curtain wall systems.

The stick built system can be constructed very air tight and resistant to water penetration. When the aluminum frames are assembled, a corner block is installed at the junction of the vertical mullion and rail. This corner block separates the glazing cavity of the sealed units from the glazing cavity of the spandrel area. It acts both to divert water into the sill cavity of the rail and as a compartment seal for pressure equalization performance. It is important to seal the corner block to the vertical mullion and rail and that it fit tightly behind the pressure plate to prevent water from draining to the IGU or

spandrel cavity below. To prevent excessive heat loss at the vertical mullion or rail pressure plate and cap connections in winter, a thermal break of EPDM rubber or other material, is placed between the pressure plate and the screw spline (slot with linear threads inside) of the vertical and horizontal mullions. This rubber-like material is not insulation, but it does provide sufficient thermal resistance between the cold pressure plate on the outside and the indoor mullion to allow the indoor temperature to warm the indoor part of the mullion above the dew point temperature (condensation temperature) of the indoor air. The pressure plate and cap enclose the drainage and vent areas of the glazing or spandrel rain screen cavities. The pressure plates are usually punched with two drains and vent holes on small units and three holes per window or spandrel opening on larger units. This is because the setting blocks are currently designed and extruded to allow moisture migration past the setting blocks to the drain/vent holes. The holes are 30 mm long by 6 mm high and punched in line with the surface of the neck of the rail component to allow drainage from the glazing cavity through the pressure plate and into the snap cap. In the snap cap, water is directed to two small holes near the ends of the snap caps, approximately 100 mm from the ends.

2.4.1. Unit System

The unit system of curtain wall installation takes full advantage of factory assembly and minimizes on site labor, but the units require more space during shipping and more protection from damage than stick system components. A glass and aluminum curtain wall fabricated and installed as a panel system is referred to as a unitized curtain wall system. A unitized curtain wall will have the same components as a stick built curtain wall system. It will comprise aluminum mullions, an IGU and a spandrel panel mounted in a prefabricated aluminum frame. However, instead of assembling the glass and aluminum curtain wall in the field, most of the system components are assembled in a plant under controlled working conditions. This promotes quality assembly and allows for fabrication lead-time and rapid closure of the building. Figure 2.14 show a typical axonometric drawing of unit system.

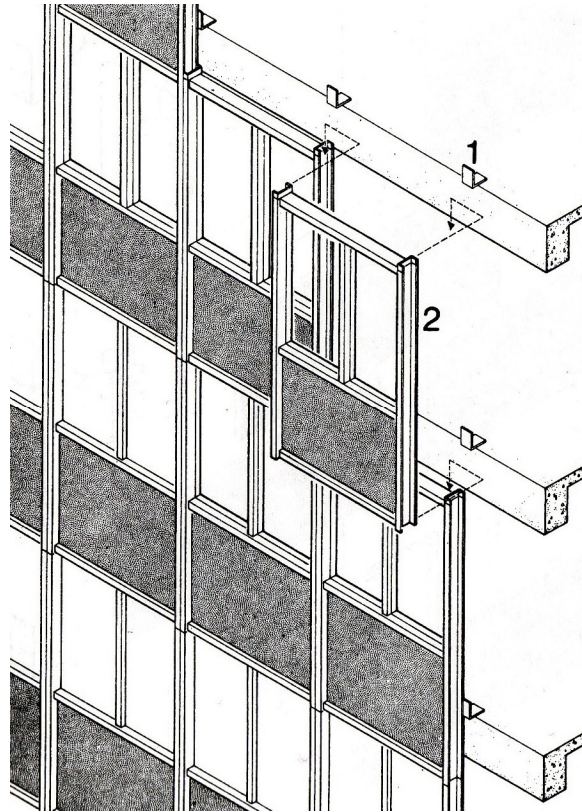

Figure 2.14. Unit systems Split mullions and tubular transoms with screw
(Source: Brock 2005)

The unitized system is assembled on the building as panels (see Fig. 4abow). The mullions and rails are fabricated as half sections instead of tubular sections, which mate at assembly time to form the curtain wall system. The panels are installed in shingle fashion, starting from the bottom of the building and going around each floor and up the building. While the unitized system offers many advantages with respect to quality assembly and speed of on building closure, there is one design concern with respect to installed performance and durability. In a stick built system, there are two joints along every mullion and rail. In a unitized system, there are three joints along every mullion and rail. These include the two glasses to aluminum joints and a third joint at the junction between the half mullions and half rails. Three joints instead of two increases the potential air and water leaks by 50% over a stick built system. Should an air or water leak develop at the third joint, there is usually no practical method of accessing the in-between panel joint for repair (see Fig 1.2.) unless the manufacturer has provided a serviceable joint system design. In a unitized system, the manufacturer must rely on qualified installers to ensure that the air seals are properly installed between the split mullions. Nevertheless, the unitized system is now as popular as the stick system

according to one manufacturer and it has performed satisfactorily when installed correctly (Quirouette 1982).

2.4.3. Unit and Mullion System

The unit and mullion system which is seldom used today offers a middle ground between the stick and unite systems. The mullions are installed first and lined through, and the pre-assembled units are located between them. The system is used where mullions with a particularly large cross-sectional area make full unit impractical. The infill units can be of one storey height in size, or separated into spandrel and vision units. The advantages and disadvantages are similar to those of a fully united wall. The size of the units is smaller in this system (Musaoglu, 2005).

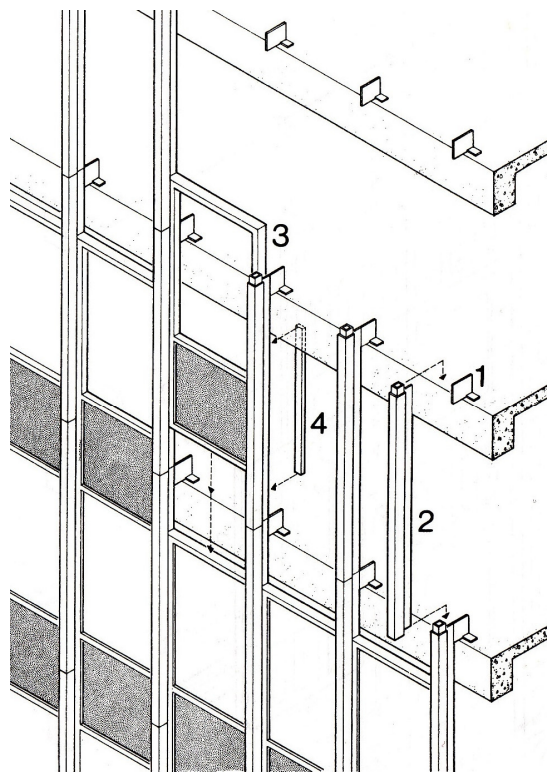

Figure 2.15. Unit and mullion system
(Source: Brock 2005)

2.4.4. Panel System

Panelized curtain wall systems appeared as a kind of cladding options: these included composite metal panels containing lightweight cores of honeycombed material or foamed plastic insulation sandwiched between two layers of thin sheet metal (aluminum or steel); precast concrete panels, custom-designed for each job, but still manufactured within a rationalized, systematic production setting; and thin stone veneer panels factory-cut to a thickness as little as a few centimeters , then attached to the building's structure using proprietary metal clips and anchors. Even traditional brick and stucco became integrated into manufactured curtain wall systems: brick as part of layered cavity wall systems; stucco, most commonly in the form of exterior insulation and finish systems, consisting of thin polymer-based plaster lamina applied with fiberglass reinforcing mesh to a surface of rigid foam insulation.

As mention in the previous paragraph, the panel system is made of homogeneous units that are formed from different materials. The advantages and disadvantages of this system are similar to those of unit system, but it's production evolves the higher tooling cost of custom-made die or mold which makes it advantages only for a building that requires a large number of identical panels or in other words standardized façade treatment. Figure 2.16 is an axonometric drawing of a typical example of Panel systems that is widely used.

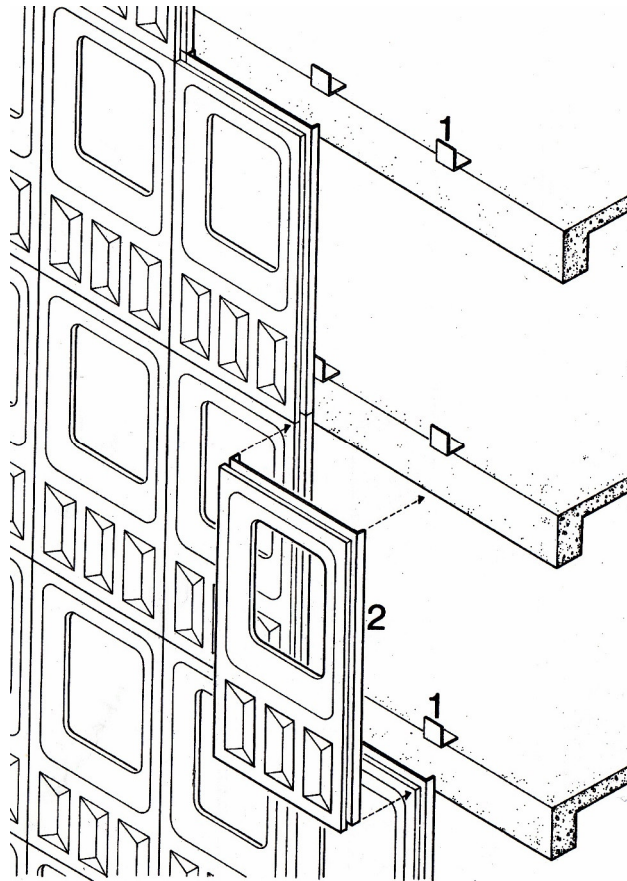

Figure 2.16. Panel system, between floor to floor.
(Source: Brock 2005)

2.4.5. Column Cover and Spandrel System

The column cover and spandrel system emphasizes the structural module of the building rather than creating its own grid on the façade as in the previously described systems do. A custom design must be created for each project because there is no standard column or flooring for buildings. Special care is required in detailing the spandrel panel support to ensure that the panels do not deflect when loads are applied to the spandrel panel support to ensure that the panels do not deflect when loads are applied to the spandrel beams of the building frame; otherwise, the window strips could be subjected to loadings that would deform the mullions and crack the glass. In the system, the column cover is installed first which may be one or two stories in height, then the long spandrel panels which span between the column cover are placed between them. Finally, the glazing infills are fixed with the frame as seen in Figure 2.17.

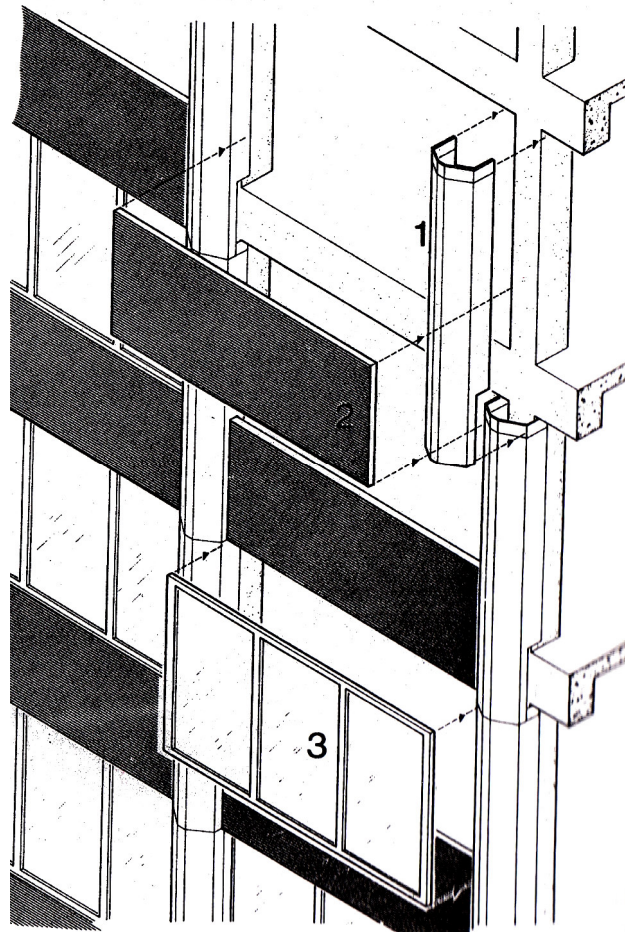

Figure 2.17. Column Cover and Spandrel System
(Source: Brock 2005)

2.4.5. Structural Glazing System

A structural glazing curtain wall system uses the same aluminum mullion components as the stick built curtain wall except that the mullion nose (neck) of the verticals is omitted to create a capless vertical joint system. In this respect, can be identified as frameless wall of glass. That's why structural glass also called bolt-fixed glass. Series o glass panels are held together with patches or bolted connections that support the glass by direct bearing and fiction. The vertical joints between the insulated glazing units are sealed on the outside with silicone sealant for a flush exterior appearance. The horizontal mullions are constructed with standard pressure plates and caps. The fittings are usually stainless steel. Lateral support can be in form of vertical mullions. In some cases steel and cable tension structures is used as vertical trusses. To hold the insulated glazing units, against the aluminum of the vertical mullion, the inner

light of the insulated glazing units is held apart from the aluminum mullion with a gasket or spacer tape and a structural silicone sealant is applied between the glass and the aluminum. The joint or contact width is about 12.5 mm.

The structural silicone sealant forms a strong adhesive bond having a minimum strength of 20 psi. When the shop drawings are submitted to a silicone manufacturer, they will often warranty an application for twenty years if it is determined that all materials are compatible by testing. Silicone sealant is vapor permeable. In high humidity indoor environments, where the structural silicone may be exposed to high humidity during winter, the silicone may require a cap bead of moisture resistant sealant to minimize the diffusion of humidity into the structural silicone glazed joint. The introduction of the glazing support attachments of the glass suspension systems and the use for structural stabilization of cables, reduce to a minimum amount of metal used. In these new systems, the geometrical configuration and the structural performance are important aspects in the architectural composition and follow a hierarchical process (Vyzantiadou 2003).

This system may be found with two or four sided capless glazing applications. Two sided applications are generally used with the vertical joints of the insulated glazing units being capless (see Fig. 2.17.) but there are a few specially designed four sided examples.

2.5. Materials in Cladding

2.5.1. Opaque Curtain Walls

Use of opaque material in wall cladding does not only affect the physical appearance of the building façade but also the detailing and components of the system are also altered. If transparency or translucency is not desired, panels of variety of materials, from terra cotta to titanium can be used in curtain walls. Commonly used cladding materials are; stone, artificial stone, concrete panels, terra cotta and ceramic panels, metal panels, wood and composite wood panels, polymer composite panels. Some of these panels are combined with glass unit in aluminum curtain-wall frame. Others are merely a screen for the rain, such as the open-joint systems or punched metal screens, while still other panels may be joined with sophisticated pressure equalizer

joints. Stone can also be cast in concrete panels, supported by a light-gauge metal truss, or directly supported by an in-situ concrete or masonry backup wall with clips. Metal can be fabricated in panels (sometimes with integral insulation) shingles, or laminated to shearing for direct attachment to a light-gauge frame.

2.5.1.1. Stone and Artificial Stone

Because both the nature of stone material and its use as cladding is diverse, engineering and installation methods are different from almost every other building component. Stone inherently variable and brittle. Its natural strength characteristics must be determined first by testing. Its natural durability characteristics are best determined by studying examples in simple exposures. Stone material properties can not be specified for a project like most other materials, and themselves do not assume safety (Lewis 1995).

Structural skeletons are not built to finish tolerances. For cladding to fit onto the frame, its construction requires adjustability. This causes ranges in the final installed conditions that must steel maintain strength. Exterior wall cladding covers all visual, structural, and constructional errors of preceding work. The façade gives the visual impression of the building. Cladding's acceptable deviations from theoretical are small particularly imperceptible. But the structural frames concealed behind the cladding reach relatively larger location errors. The building's skin system adjusts to the frame to attain finished accuracy during installation. It must maintain both structural and environmental integrity after installation through the environmental extremes experienced during the building's life.

In addition to its structural functions, the stone cladding in a building skin must also resist environmental elements. It must successfully refuse air and moisture infiltration and filters the sun, temperature, and sound. Some of these exposures are predictable and some are not. Cladding stones depend upon their support systems to maintain their structural integrity. Cladding stone also depend highly upon the thermal and moisture integrity of the wall behind to maintain their durability. A correctly selected stone that is supported soundly by a wall system with proper environmental qualities will remain beautiful. Preserving stone's aesthetic quality requires anchorage and envelope performance to be compatible with the selected stone material.

Knowing flexural stress distribution within the panel is extremely important in the design of a brittle, non-plastic material. Stone is highly sensitive and unforgiving to stress concentrations that are the result of one-way bending. Force flow within the panel is to one area and if the panel has any faults or weakness at that location early failures become much likely. Some benefit is to be offered to the retention systems that recognize the inherent tendencies of the types of anchorages used and their layouts, which respond more favorably to the nature of stone as a structural material.

With a linear-type anchorage such as a kerf bar, which may only be effectively supporting the panel at its corners, for instance, is steel engaging the stone panel a cross its entire width failure of the stone at the original support location does not cause the stone to be released from the façade because the stone panel is still “captured” by the kerf bar within the remaining portion of the stone’s kerfed edge. Instead, the stone panel’s reactions are transferred along the length of the kerf bar where the stone is still intact. Intermittent visual inspection of the façade will discover these conditions, which can be repaired or otherwise correctly restored, without failure injury or damage.

There are many parameters that influence stone cladding performance. Each parameter or uncertainty should be checked during conceptual design to compute overall system adequacy. Work adjacent to the stone panels create the engineering context of the stone panels. The exterior wall structure, the thermal and moisture envelope, and primary building frame determine the boundary conditions. How does the systems interact control the function of the complete cladding system. Their reaction to climatic forces and building use, which are applied by skins reactions to those forces compose a complex, dynamic interrelationship that must be change and adopt endure.

Both ferrous and nonferrous metals are used in anchorages and exterior wall framing. When used against stone or together in the wall system, moisture, mineral and metal contact must be controlled. Prevent direct deleterious contact and indirect potential contact caused by moisture migration in the hidden internal wall environment.

2.5.1.2. Concrete Panels

Precast concrete panels are preferred because of their durability and low costs in cladding. Their quality of the finishing highly depends on the design and fabrication of the panels, in other words, the ability of precaster. The concrete can be cast with a

variety of finishes and of colors by using stone aggregates of different colors, types, and sizes. Fired-clay and stone tiles can be cast integrally with the concrete. One of the most important factors effecting quality of concrete cladding system is the detailing problems of the panels with the building envelope. While the concrete effectively prevents air and water penetration the joints are where most problems occur. As its known concrete is not a good insulator, and additional thermal insulation entails much more attention. As seen in the next figures in precast cladding designs a two-stage drained sealant joint, and an air barrier system is required in thermal insulation.

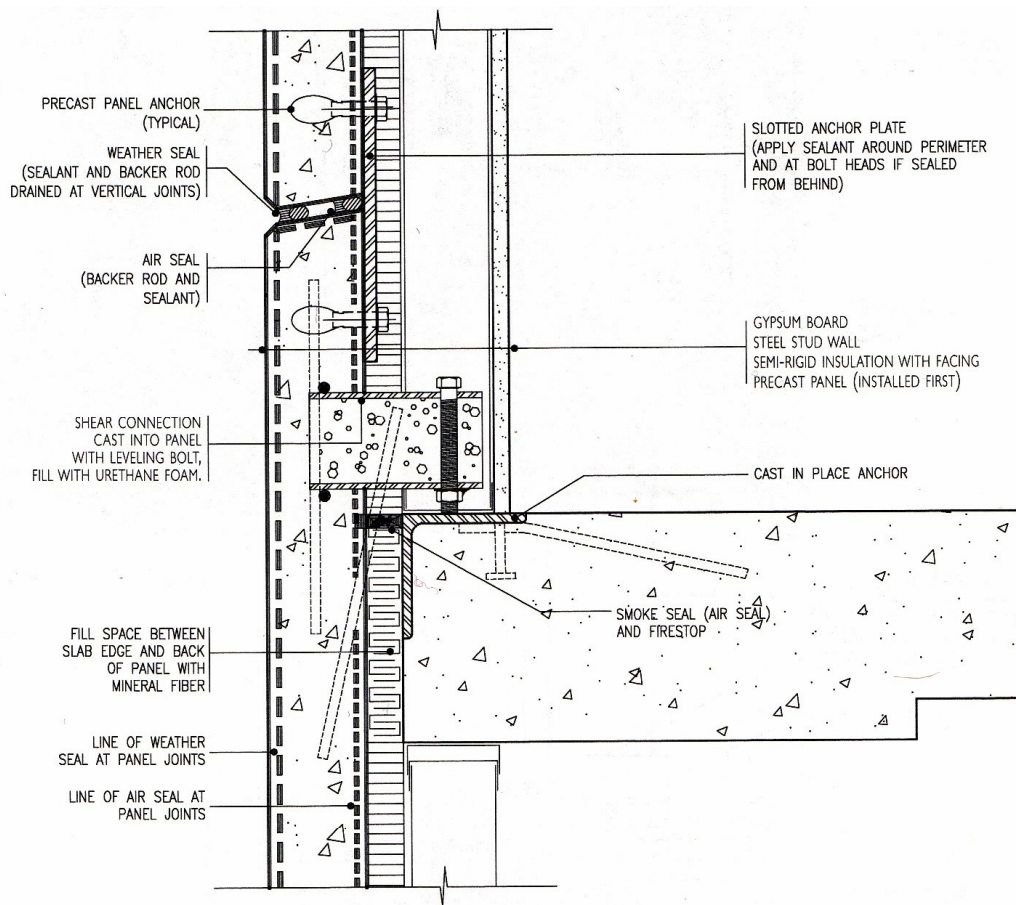

CONVENTIONAL PANEL
SLAB BEARING CONNECTION

BEST PRACTICE GUIDE
ARCHITECTURAL PRECAST CONCRETE WALLS

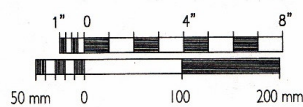
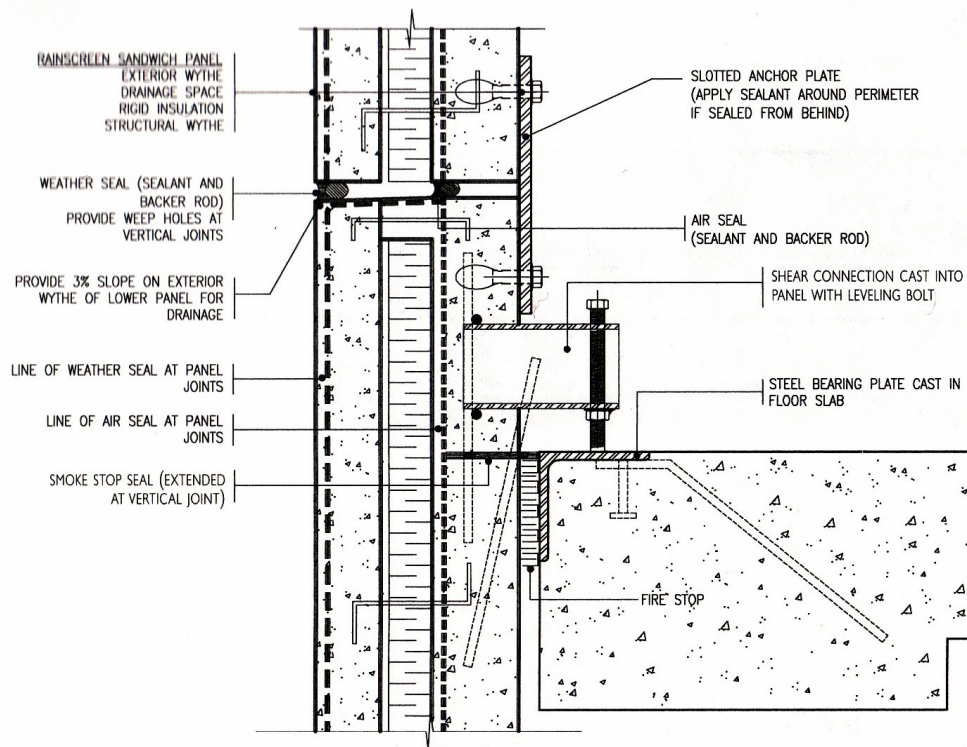

Figure 2.18. Concrete panel slab bearing connection detail
(Source: Brock 2005)



SANDWICH PANEL WITH RAINSCREEN
BEARING CONNECTION TO SLAB EDGE

BEST PRACTICE GUIDE
ARCHITECTURAL PRECAST CONCRETE WALLS

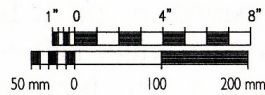

Figure 2.19. Precast concrete panel isolation details
(Source: Brock 2005)

Whereas in buildings clad with precast concrete panels with integral insulation, it is necessary to provide two-stage drain joints between the panels. The inner seal must continue to the air barrier at the back face of the panels. Flashing integral with the insulation weepes any condensation to the exterior. Figure 2.17.-18.-20. are the examples and details of Precast concrete panels. Manufacturing of these panels that is done out site of concrete panels can be also be seen in Figure 2.20.

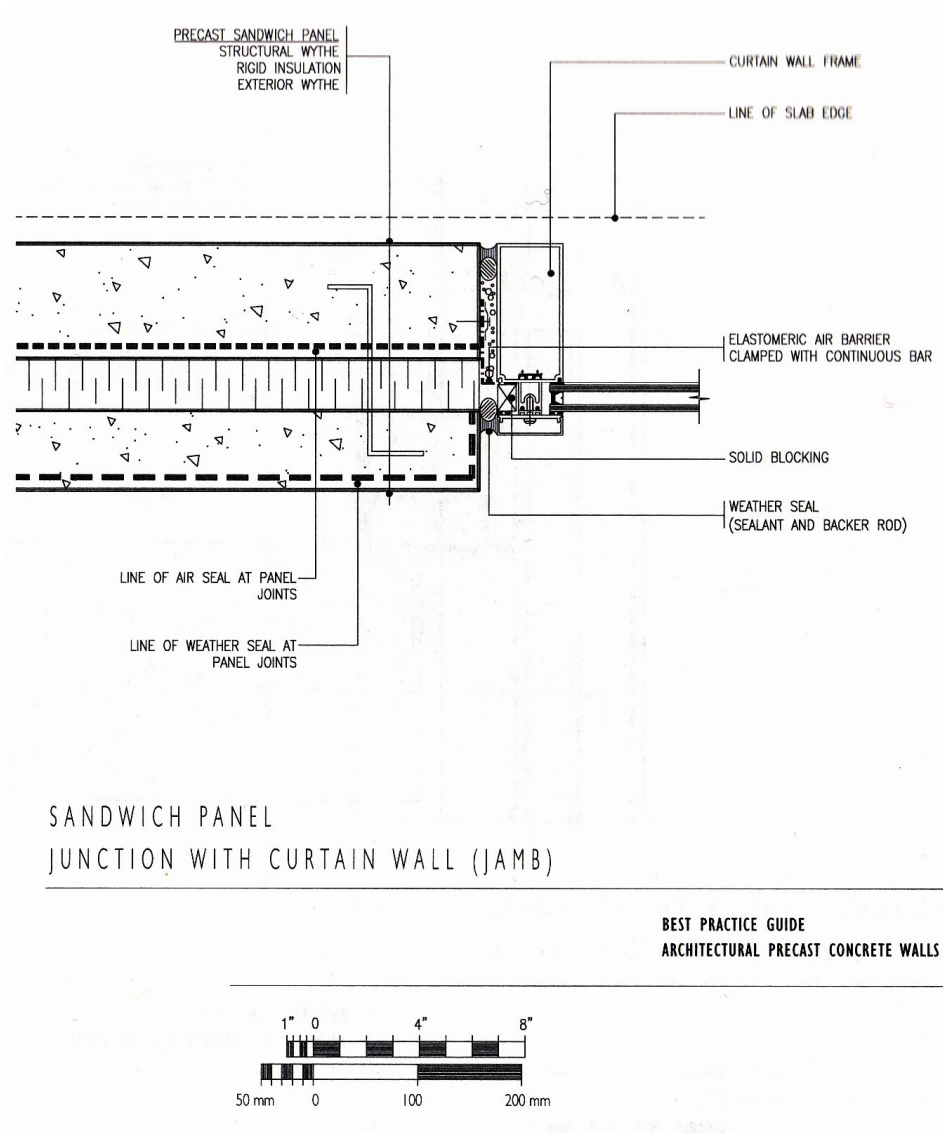

Figure 2.20. Precast concrete panel with integral thermal insulation
(Source: Brock 2005)

The disadvantage of the concrete panels is their weight. In search of lighter-weight claddings, glass-fiber reinforced concrete was manufactured. Beside its weight glass-fiber reinforced concrete has several advantages over precast concrete panels. Its admixture of short glass fibers furnishes enough tensile strength that no steel reinforcing is required. Panel thickness and weights are about one quarter of those of conventional precast concrete panels, which save many on shipping, makes the panel easier to handle, and allows the use of lighter attachment hardware. The light weight of the cladding also allows the load bearing frame of the building to be lighter and less expensive. glass-fiber reinforced concrete can be molded in to three dimensional forms with intricate detail and extensive range of color and textures (Allen 2004).

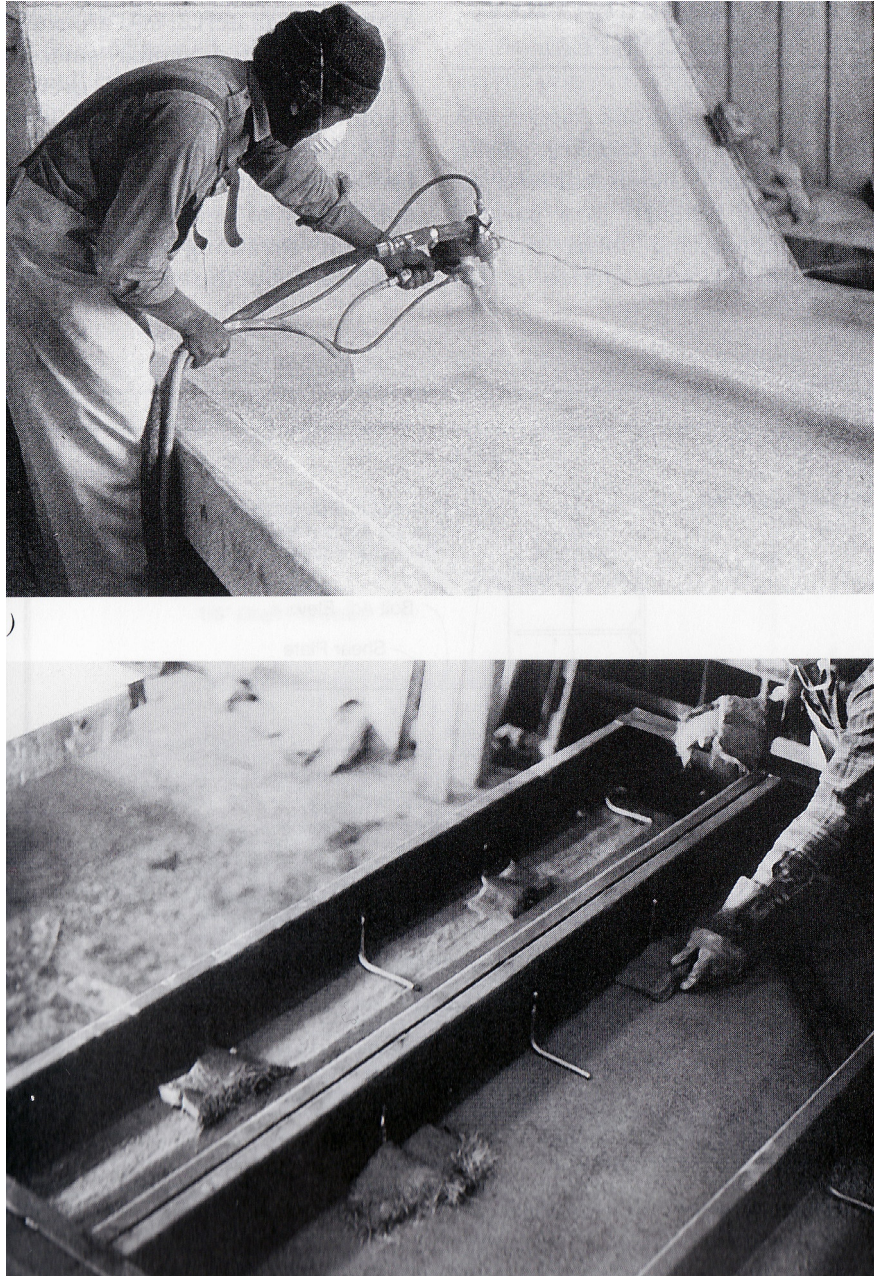

Figure 2.21. Fabrication of GFRC curtain wall panel
(Source: Allen 2004)

The fibers in glass-fiber reinforced concrete from a special alkali-resistant type of glass to prevent their disintegration in the concrete. The panels may be self-stiffened with glass-fiber reinforced concrete ribs but the usual practice is to attach a welded frame made of light gauge steel studs to the back of glass-fiber reinforced concrete facing in the masonry. The attachment is made by means of thin steel rod anchors that flex slightly as needed to permit small amounts of relative movement between the facing and the frame. The next figure shows the typical ways of attaching metal framed

glass-fiber reinforced concrete panels to the building. The edges of the glass-fiber reinforced concrete facing which is usually about 13mm thick are flanged as shown in the drawing so that backer rods and sealant may be inserted between panels (Figure 2.22.).

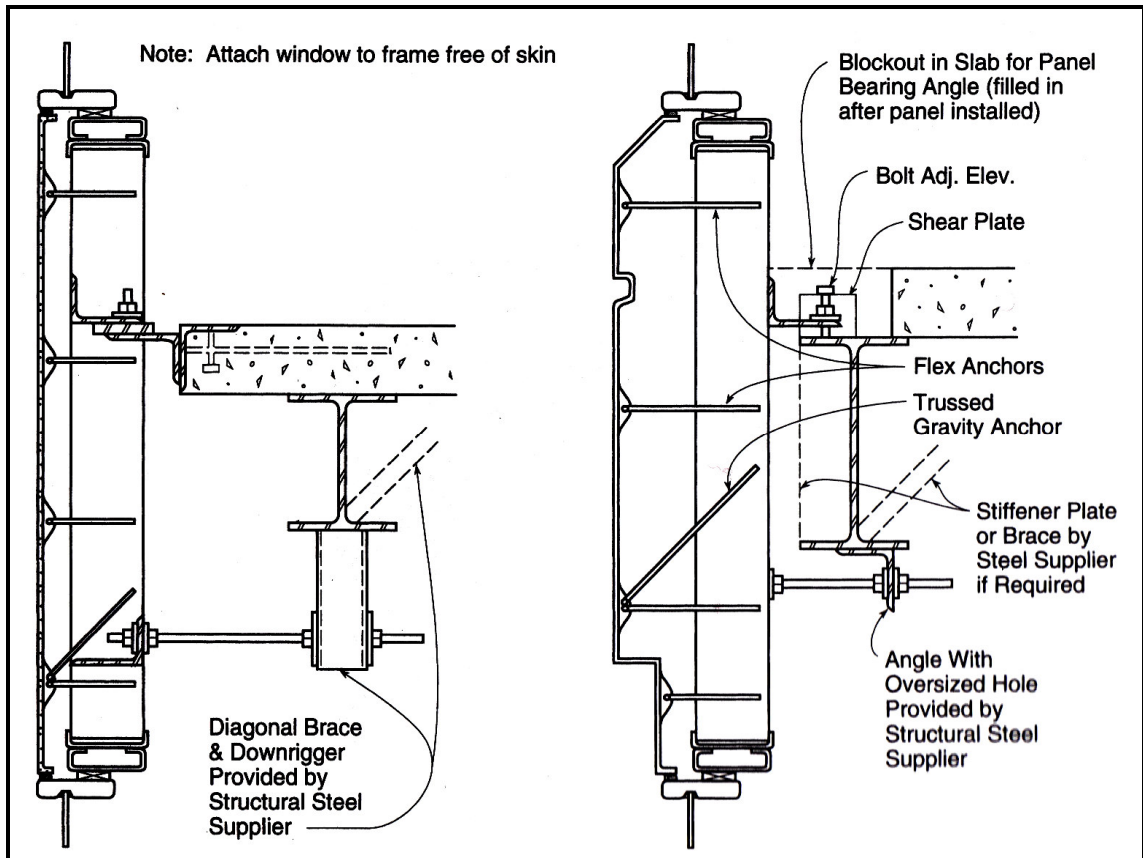

Figure 2.22. Typical connections of GFRC panels to a steel building frame (Source: Allen 2004)

2.5.1.3. Terra-Cotta Ceramic Panels

Terra cotta is a hard, semi fired, waterproof ceramic clay used in pottery and building construction. Used mainly for wall covering and ornamentation as it can be fired in molds. Oftentimes, white or colored glaze is applied on the face of the brick. Terra cotta is a form of hard-baked pottery, widely used in the decorative arts, especially as an architectural material, either in its natural red-brown color, or painted, or with a baked glaze. As being one of the oldest building materials is a durable and aesthetically pleasing material when used properly. In modern practice terra-cotta is manufactured from carefully selected clays, which combined with water and vitrifying

ingredients, are put through a pug mill (mixer) or other device to reduce the mass to homogeneity. In cakes of convenient size the clay passes to the molding room. Individual pieces are modeled by hand or machinery equipment; in the case of repetitive pieces, the clay is pressed into plaster molds to form a shell. After are taken from mold, and then are ready for baking in a kiln or reverberatory furnace.

Newer methods of attachment use stainless-steel fittings and anchors. Today terra-cotta is a recognized material- it has a beauty of its own that can not be replicated. Often hand-pressed terra-cotta pieces are used as decorative elements in a field of less expensive cladding, such as anchored brick veneer. Terra-cotta pieces are also produced by extrusion methods similar to the manufacture of extruded clay brick. These extruded pieces are more economical as the articulation is unidirectional.

Exterior wall cladding with terra-cotta requires different dimensioning and qualifications comparing with conventional brick. Relatively small size of tiles simplifies installation. The 30-mm thick tiles come in heights (the extruded dimension) of 150-250 mm with 225 mm being the most economical lengths variety from 150-500 mm, with 450 mm being the most economical. Exact lengths can be cut easily on the jobsite (Brock 2005).

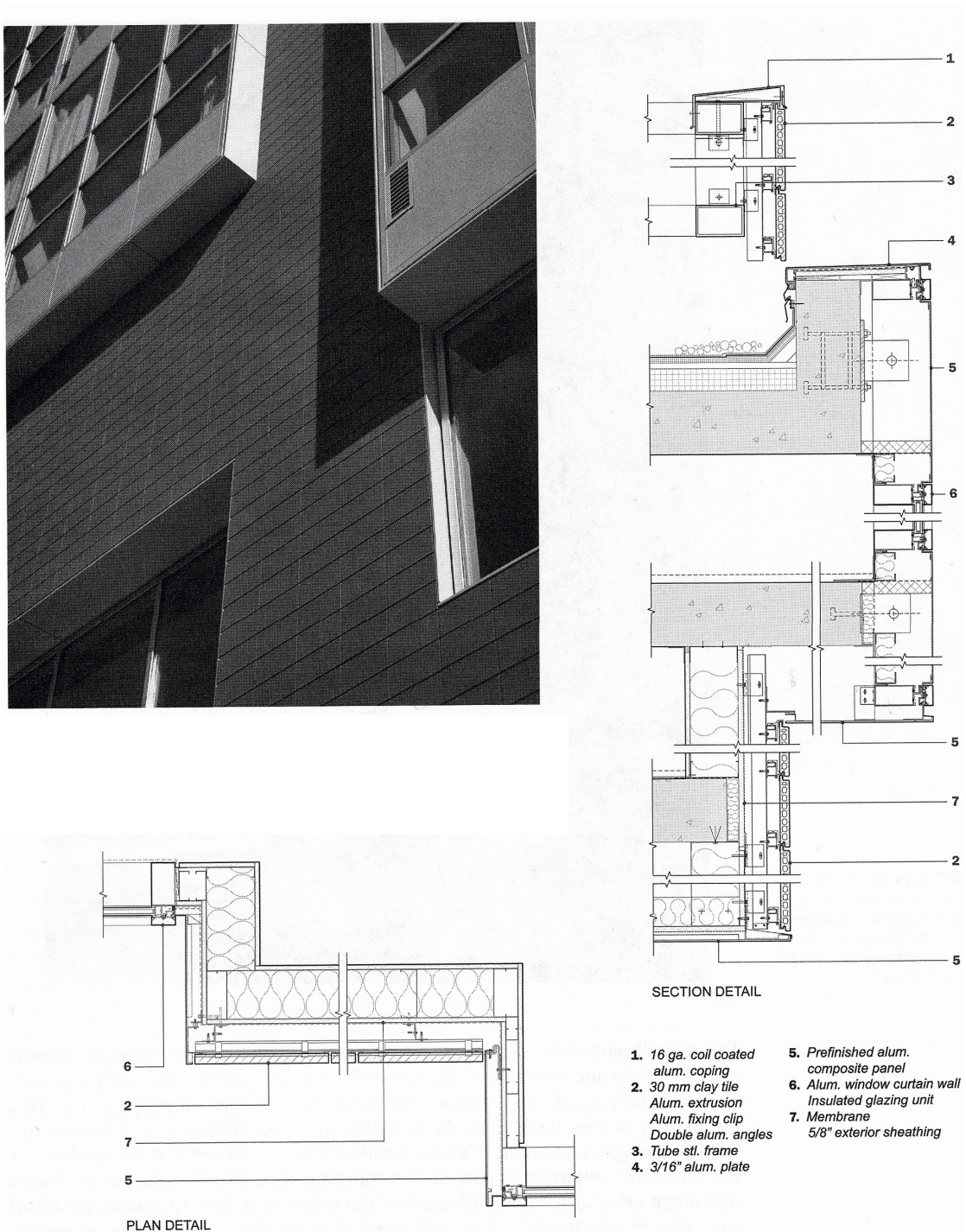

Figure 2.23. Details of terra-cotta tile cladding
(Source: Allen 2004)

When installing the panels, minimum 25 mm air space or other capillary break is required by manufacturer between brick panels and insulation. Use of weep holes at flashing locations to vent moisture build-up in the wall cavity is necessary. It is also necessary to minimize penetrations of insulation by structural elements, wall attachment

devices, etc. In constructions using vapor retarders, careful consideration should be given to maintaining vapor retarders' integrity.

The following figure which is taken from Allen's book, show the use of prefabricated reinforced brick panels for cladding. Masons construct the panels while working comfortably at ground level in a factory. Horizontal reinforcing may be laid into the mortar joints or grouted into channel shaped bricks. Vertical reinforcing bars are placed in grouted cavities o hollow-core bricks. These panels are self-rigid; they need to structural backup and can be fastened to the building in much the same way as precast concrete panels. A steel stud backup wall is required to carry thermal insulation electrical wiring, and an interior finish layer, but has no structural role.



Figure 2.24. Fabrication and insulation of a brick panel curtain wall
(Source: Allen 2004)

2.5.1.3. Metal Panels

Aluminum and stainless steel are the most commonly used metal material in the field of cladding. Recently, titanium is starting to be seen on building claddings even it is an expensive material. All the metal panels can be used in the form, sandwich panel or thin metal panel.

A. Aluminum: Aluminum because of its own feature is very appropriate material for external use. Three primary reasons in choosing this material are very effectual. These are can be identified as follows: First, aluminum protects itself against corrosion. Second, various surface treatments can be applied to the material including color, texture, brightness etc. And the third, it can be fabricated economically into elaborately detailed shapes by means of process of extrusion. (Figure 2.25.)

Aluminum cladding is easy to erect because of its light weight and simple connections. Little waste or pollution is associated with the process. Scrap is readily recycled. This type of cladding seldom needs maintenance, lasts for a long time, and can be recycled when a building is demolished. But as the material is highly conductive of heat, cladding components must be thermally broken.

The two most common aluminum panels are honeycomb backed and aluminum composite panels. In the first type the stiffness of the aluminum is increased by plastic, aluminum or stiffing paper. This is an advantage when structural or thermal properties need to be increased, but the system requires custom detailing. The more popular aluminum composite material can be formed in to curves and usually less costly and easier to install than other aluminum panels, as standard details have been developed for its thin profile. Aluminum composite materials were developed under the trademark of Alucabond made by Alcon in North American in late 1970's. Foamed aluminum panel is also available form of aluminum panels in market. The standard 50mm thick panels come clad with steel, zincalume, or aluminum, with various finishes. The metal skin covers expanded or extruded polystyrene, polyurethane, or rock wool insulation. Panels up to 10 m. in height are available as well as curved forms.

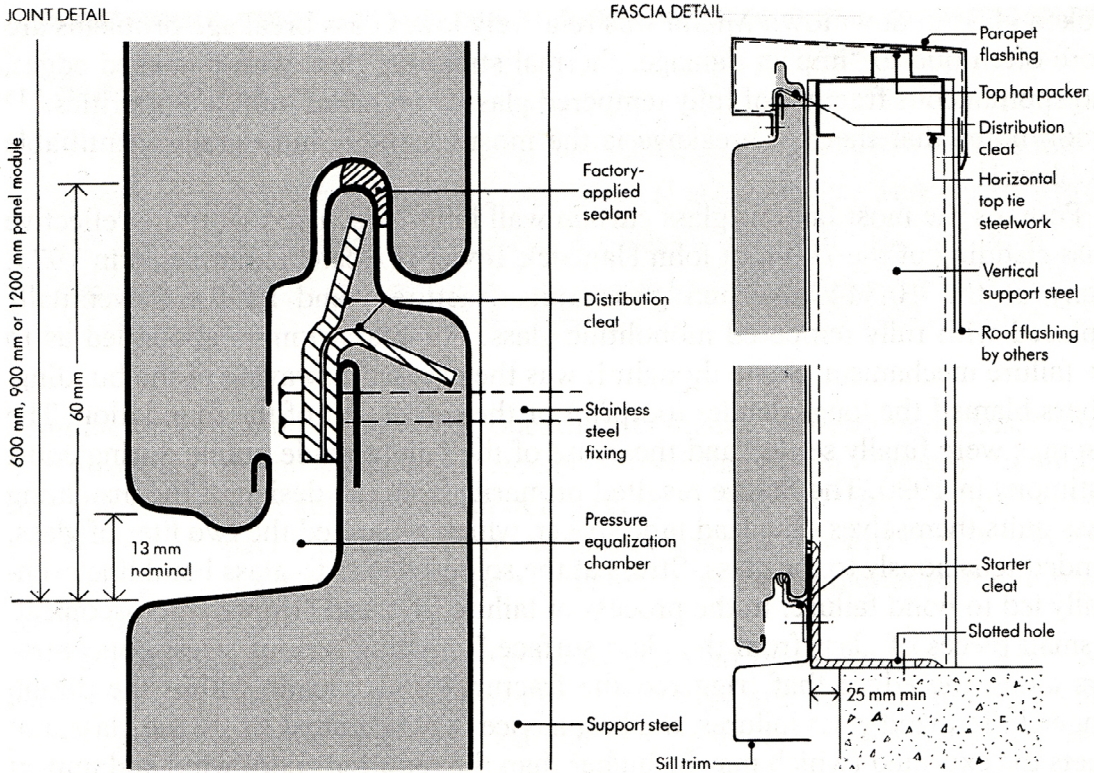

Horizontal

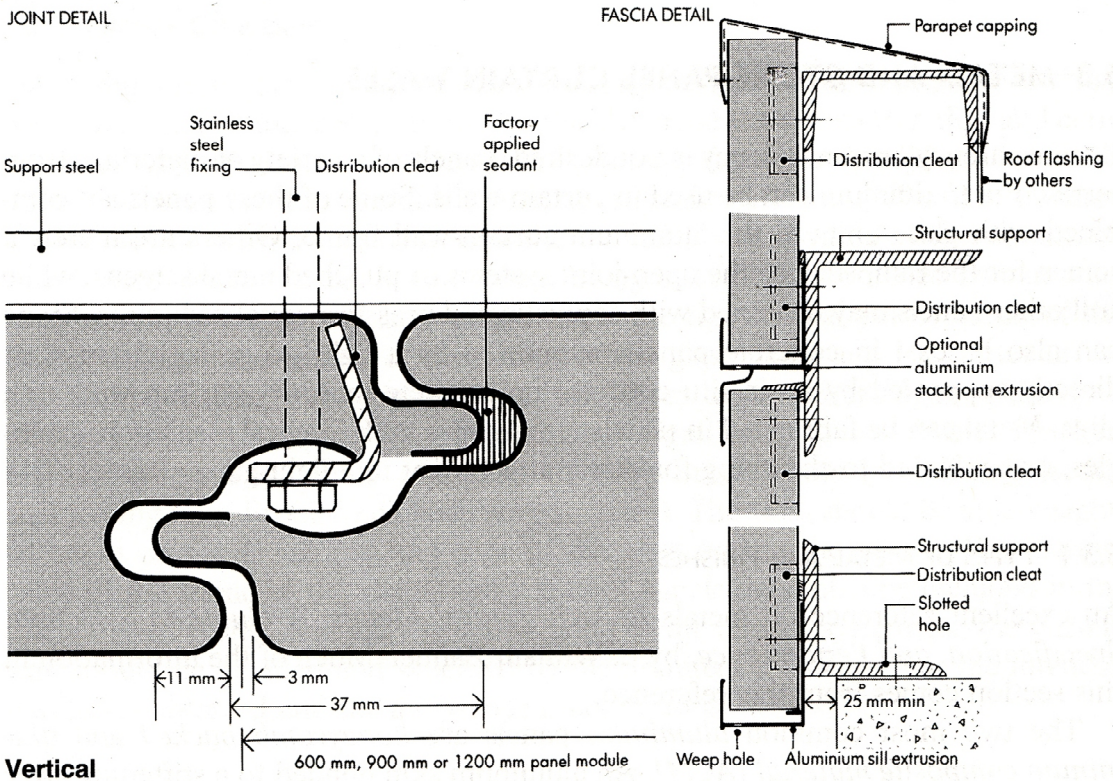

Vertical

Figure 2.25. Horizontal and vertical joint between metal panels creates a pressure equalization chamber (Source: Zahner 1999).

B. Stainless Steel Panels:

Stainless steel is a long lasting material with relatively low cost advantages. There are different kinds of finishes, including highly reflective, matte, smooth, brushed, and embossed. Deep reach hues, which “no paint can even come close to” can be produced with a process called light interference on stainless steel and also titanium (Zahner 1999). Various finishes can be factory applied including a terne coating that has an appearance similar to lead. Terne is an alloy of lead and tin, with the tin helping to bond the lead to the steel. Terne coated stainless steel is referred to by the initials TCS: For standard corrosion resistance, 304 alloy stainless steel is commonly used; 316 alloy, with molybdenum, can be specified for even greater protection in costal areas or areas with high pollution levels. The primary disadvantage of stainless steel is the initial coast. However the life- cycle coast makes it more economical when compared with less durable materials.

Steel with various finishes offers lower coast alternatives. Steel needs to be protected from corrosion, generally by a sacrificial zinc coating. Galvalume (another trade name is Zinalume) has a hot dip zinc and aluminum coating and is produced by most major steel manufacturers. It offers betweenter corrosion resistance than just galvanized metal. If the cut edges are protected, the Galvalum coating lasts five to ten times as long as the coating on G90 galvanized steel in salt spray tests. The first commercial sheets were fabricated in 1972. An acrylic coating, part of Galvalume Plus, protects the sheets during transit and storage and eliminates the need for varnishing oil that must be removed on-site. If a uniform appearance is desired, the product should be repainted by the manufacturer, as even Galvalume Plus will exhibit the normal variations seen with all hot dip products.

Sheet metal can be sprayed with paint as individual pieces or “coil coated” as flat material. The coil finish must be more flexible, with between adherence than a spray applied coating, as the coil coated metal is recoiled after it has been painted.

Weathering steel in plate form has been used for cladding. The thinner sheet materials had durability problems and are no longer produced. Careful detailing, to ensure that the steel is always dry, by eliminating pounding opportunities and using a thickness of 0.8 mm or grater, has alleviated most of the durability problems.

Zinc is well known for its high corrosion resistance when combined with titanium and copper, it is a malleable and strong material with a natural blue-gray

appearance. Zinc panels should be well in ventilated on the on the non-exposed surfaces. Water from condensation or leaking can dissolve the metal relatively quickly.

C. Titanium is also a popular but costly material, which is rarely used in distinguished example of architecture. But because of the cost factor it doesn't used commercially in industrialized cladding system.

2.5.2. Transparent Curtain Walls

The very first material evocation of curtain wall is glass. As it is known glass is one of the most common and also one of the oldest building materials. Its feature and material properties are developed during the course of history. Today it is possible to find different types of glass that is produced for specific needs in building market. But according to Wiggenton, The development in glass enormous but they are concentrated on finishes and coatings, and gases for insulated units, and small manipulations on float glass. Spurred by energy concerns, aesthetics and safety concerns, much invention continues to occur within these areas. Beside these, further expectations from glass are; non reflectivity, minimizing heat transfer, resisting on impacts, control over elusiveness, and clearance.

Glass can be annealed; heat strengthened such that its bending strength is double that of annealed, with four times the bending strength of annealed glass of the same size and the thickness. These types can than be laminated with a plastic film between two lites for safety reason or increased sound resistance. Lamination is also used to protect coating. Insulations units of two or more units held apart with a spacer usually of aluminum or stainless steel, increase thermal resistance. The spacer contains a desiccant to keep the air space free of visible moisture. A single or double seal around the unit insures the space is hermetically sealed. Warm-edge technology recognizes the advantages of lower thermal conductance at the edge of insulating units by using low-conductance spacers. This not only decreases heat loss but helps control condensation (Brock 2005).

One of the best glass types is float glass. Light transmittance ratio is very high in float glass. For example 75-92 percent of visible light can pass on, depending on the thickness and the composition of the glass. Float glass usually have a greenish tint expect low-iron glass is specified. Beside this tint different colors are available in the

markets; such as bronze, gray dark gray, aquamarine, green, deep green, blue and black. Tinting absorbs and in that way reduces diminish solar transmittance.

Coatings have very important function on improving material quality of glass. By using coating on the surface of the glass, absorption, reflection, and radiation of solar energy can be reduced. The most common coatings are solar reflective glass, and low-emissive glass. Reflective coatings are in silver, blue gold and copper colors. Other type of glass is low-energy glass. This glass reflects long wave, infrared energy. Some coatings are also reflective of the whole infrared spectrum. Depending on the climate, coatings by reducing heating ventilation and air conditioning (HVAC) expenditure provide large amount of energy savings. Selection of appropriate coating on the correct surface is depends on the climate.

A glass cladding system may be designed to be outside glazed, which means that glass must be installed or replaced by workers standing on scaffolding or staging outside the building. Cladding system may also be designed to be inside glazed by workers who stand inside the building. Replacement of glass may also be done from within the building. Inside glazing is more efficient and common in high rise buildings, but it also require more elaborate set of extrusions. Whereas, relatively simple set of extrusions are used on “outside glazing systems”. The system is cheaper than inside glazed systems especially for the buildings with two or three stories tall buildings whose walls workers can easily reach from external scaffolding.

One of the distinguishing features of glass claddings is the problem of rain penetration in between the panels or frames. That’s why; both rubber gaskets to seal around the glass are to be considered precisely. If the inner and outer gaskets around a light of glass is defective many problems occurs. This can happen as a result of the wind driven-rain or capillary action. The water that passes from the outer gasket into the space between the edges of the glass and aluminum can damage the skeletal frame of the cladding and materials inside. For example if water has leaked in along a vertical edge of the glass, it is contained within the vertical mullion and will fall by gravity to the bottom, where it drains out through weep halls. If water accumulates in horizontal mullion, it is prevented from running out of the ends of the mullion by rubber end plugs, which are seen in the Figure 2.26.

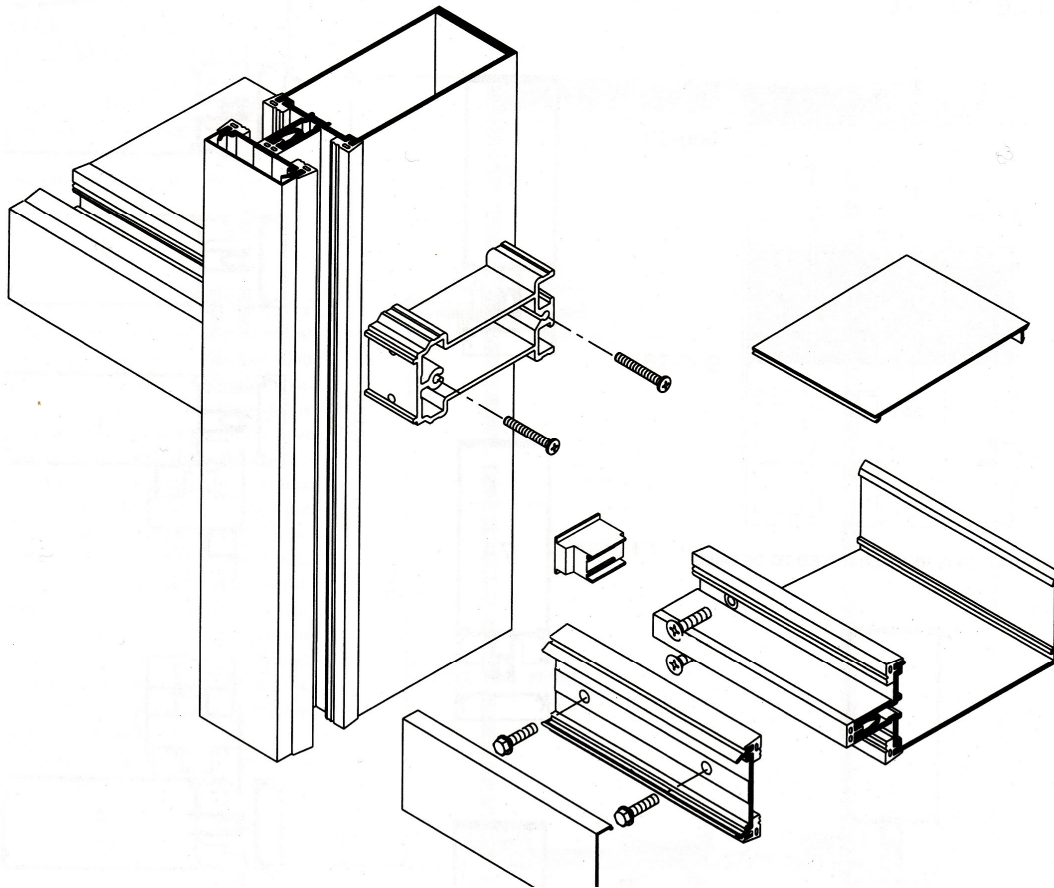

Figure 2.26. An example of outside glazed stick system
(Source: Allen 2005)

In glass claddings the entire system works as a rainscreen assembly. In practice however, the responsibility to take every precaution to prevent passage of water is belongs to the installers and manufacturers and they are to assure that the outer gaskets are properly installed.

Another important issue of glass cladding systems is “expansion joints” Because of the different behavior pattern of metal frame and glass, expansion joints become an important detail problem to solve. As it is very well known, thermal expansion coefficient of metal which is used in the frame of cladding systems is higher than glass. For example, the coefficient for glass is less than half as much of aluminum. As the building façade exposed to direct heating by the sun, it is necessary to provide expansion joints to allow thermal movement to occur without damaging the cladding or the frame.

The difference in thermal movement between glass and aluminum are generally accommodated by very small sliding and flexing motions that occur between the glass

and the gaskets in which it is mounted figure 2.27. Rubber blocks placed between the edge of the glass and the mullion on either side of each light prevent the glass “walking” too far in either direction during repeated cycles of heating and cooling (Allen 2005). In the next drawing, vertical thermal movement in the aluminum is absorbed by telescopic joints that are provided at regular intervals in the vertical mullions. Horizontal thermal movement is accommodated by intentionally cutting horizontal aluminum components slightly short by a calculated fraction of 2cm at each vertical mullion.

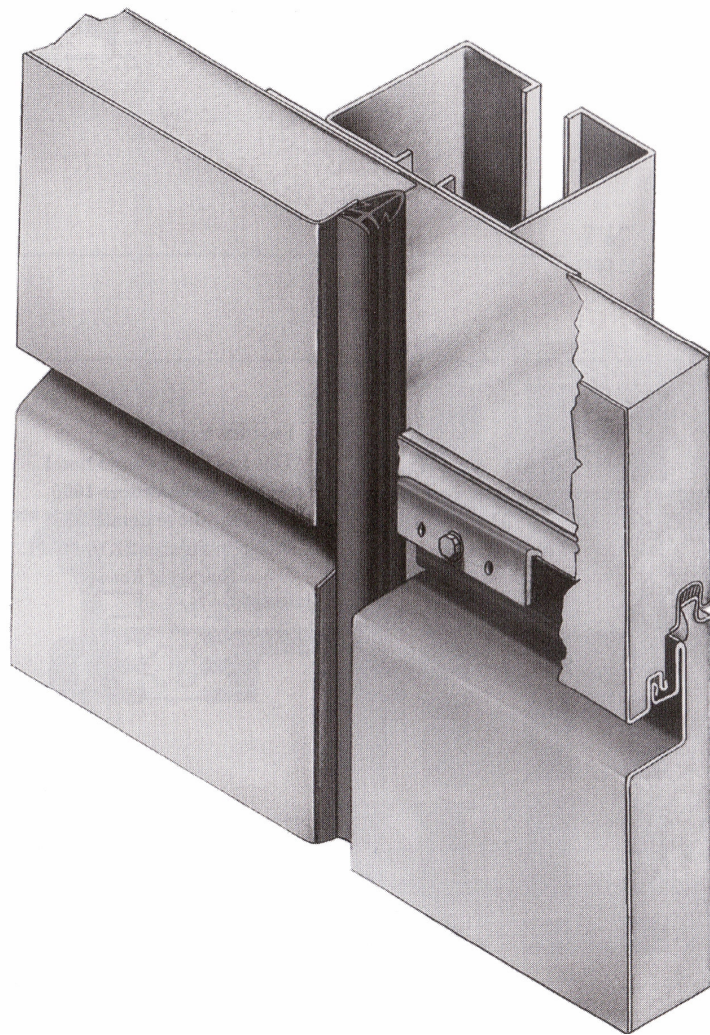

Figure 2.27. Vertical joints between Aluminum panel system
(Source: Allen 2005)

CHAPTER 3

DESIGN AND CONSTRUCTION WITH DIGITAL TECHNOLOGIES

3.1. Digital Applications in Design

The design and manufacture of today's increasingly complex products relies to an ever greater extent upon the use of computer and information technologies. These technologies also change the attitude of designing practice and physical appearance of the end product. On the other hand the relations and methods of conventional production still continue to exist. Because of this reason practice and production of most of the design fields are still executed by the conventions established by industrial society. The adaptation of the field of architecture to the newly developing technologies inevitably, brings about some adaptation problems and hybrid technologies. The new technologies, like the industrial technologies, are not only transforming the design process but also effect the manufacture and construction processes. In the conceptual realm, computational, digital architectures of topological, non-Euclidean geometric space, kinetic and dynamic systems, and genetic algorithms, are supplanting technological architectures. Digitally driven design processes characterized by dynamic, open-ended and unpredictable but consistent transformations of three-dimensional structures are giving rise to new architectonic possibilities (Kolarevic 2000). The generative and creative potential of digital media, together with manufacturing advances already attained in automotive, aerospace and shipbuilding industries, is opening up new dimensions in architectural design. The implications are vast, as; architecture is recasting itself, becoming in part an experimental investigation of topological geometries, partly a computational orchestration of robotic material production and partly a generative, kinematic sculpting of space, as observed by Peter Zellner in "Hybrid Space" (1999). The first digital applications of computer aided design (CAD) and computer aided manufacture (CAM) has been realized after the year of 2000. These applications created new opportunities by allowing production and construction of very complex forms that were until recently very difficult and expensive to design, produce,

and assemble using traditional construction technologies. The consequences will be profound, as the historic relationship between architecture and its means of production is increasingly being challenged by new digitally driven processes of design, fabrication and construction.

3.1.1. General Definitions and Functions of Design Tools

Building production, like other production processes, relies on design. The creation of a non-existent object is dependent on developing the product and transferring its information. This process, which we term as “design”, is in the first place directly related to individual perception, ways of interpretation and expression. “Design”, therefore, can be defined as a mental field of activity connected with the ability and capacity of human brain. Nonetheless, it is not possible to restrict the design process merely with human factor. All three-dimensional objects are conceived as a result of a complicated process in which the designer simultaneously evaluates diverse factors. For example, several conditional variables, such as material, form, form articulation, environmental factors, dimensioning and detailing, should be considered concurrently. Multiplicity and interdependence of the inputs bring forth the insufficiency of the capacity of human mind alone in the conduction of design activities. This inadequacy stems also from the manners of human perception and contemplation. The development of design tools grows out of these two fundamental factors. Due to these two principle aspects, various tools are required for carrying out designs. These tools, which are formed within a framework determined by social and cultural conditions, are effective on the formation not only of design practice, but also of the end product. Under the light of these facts, design tools may be defined as the means, medium and methods that are developed to be utilized in the production process of all kinds of artifacts, and serve both in directing the cognitive processes of the designer and in transmitting the product information.

Drawing-based representation techniques constitute the most common design tools today. The representation of any object that is being designed has two main functions: It is a means of communication and it is a vehicle for exploration. Representation as a means of self-communication gives the designer the opportunity to ponder what he/she has done and to make revisions out of this consideration. Studying

the representation allows the designer to shift his/her attention from one aspect to another. The representation is expected to answer several hypothetical questions when it is used with a purpose of exploration. It is a variety of obtaining knowledge about intended artifact, of probing into the consequences of tentative decisions about it, thereby providing a basis for rejection or approval of such decisions (Galle 1999). Apart from the functions of design tools, the question of what they are should also be earnestly deliberated. Design tools, just like linguistic constructions, are the vehicles of both thinking and communication. Along with the fact that no thought can exist independent from language, it is almost impossible to design something unique and coherent without using these tools. In other words, when considered in terms of the connections between language and thought, the drawing techniques are the language that the designer uses as a means of thinking. This means is a many-sided vehicle, which also provides communication. Various free-hand techniques such as esquisse, conceptual diagrams and sketch; orthographic projection methods like three dimensional visualization techniques like axonometric and perspective drawings are all like the words or sentences of this language. These words and sentences, by following one another in a sequence, provide the development of the thought that is the design. Notwithstanding the fact that some verbal and discursive modes of expression have an impulsive effect in artifact production, the most significant tools used in design process are the above mentioned drawing techniques.

The transformation of design tools is the projection of a total change in the field of design. Design tools that emerge as cultural products alter in accordance with the transformation in the relations of production. Hence, the design tools, which seem to be crucial within our social relationships, do not bear a universal value. It is possible to distinguish different design tools shaped under various cultural effects through history. In short, drawing conventions that we use today must be held as a reflection or an instrument of contemporary social practice. Drawing techniques that we use today are, at the same time, the main tools providing a connection between the cultural creation of architecture and its social production. As a way of action and thinking, they survive both as a social form of production and as an autonomous concept. Therefore, they not only bear the peculiarities of an art object, but are also a part of the social discourse. These features are expressed in the words of Robbins as follows: "It is an idea and an act includes the relationships between the society and culture, between realization and imagination."(Robbins 1994).

Drawing-based design tools have been developed within the scope of the design forms of industrial society concretized with the Bauhaus School. This tool, which was originated by industrialized capitalist societies, has not been widely seen in previous periods. As a matter of fact, any retrospective study on architectural drawing techniques or design methods may easily prove that drawing in architectural practice is a tool peculiar rather to Renaissance and latter periods. Yet, this does not signify that no design activity was carried out in previous periods or the accomplished designs were not sophisticated enough. Prior to the age of Humanism, the role of design tools was undertaken by the rigid rules of traditions.

The evolution from traditional societies, in which anonymous values in design were brought in the fore grounded, to modern societies, in which individuality is emphasized, has been marked since the fifteenth century. The transformation of design tools has begun in parallel to this progress and has taken its contemporary shape together with the industrial revolution. While the emergence of drawing techniques as a means of criticism and production since the mentioned period has elevated the status of the architect from craftsmanship to artistry, it caused very significant shifts in the activity fields of the profession.

Accordingly, it is possible to deduce that the transformation of design tools has dramatically converted the professional practice and architectural form. The transformation engendered by *longue duree* and the effects of economical factors has, by all means, generated from sources outside the field of architecture. Whatever their definition and explanation may be today, it has generally accepted and been agreed on that there has been made significant progress in information tools and technologies and this issue of fact is extensive enough to affect the social division of labor. The increase in the capacity of data processing and communication has been effective not only on the methods of production, but also on social life and the individual. The impacts of this period, which is trying to be explained through paradigms like globalization, mobilization of investment capital or transition to information society, has influenced not only the field of architecture but also all social areas. According to many theorists, this situation has become clearer. For example, Zeller clarifies this issue stating that “cultural and social revolution brought on by communication and information technologies is rapidly transforming the field of architecture.”(Zellner 1999). The structural shift, which will be accompanied by the process of transition to information society, appears with an effect potential similar to the one in the transformation

experienced within the period of transition from traditional to modern society. The attitude and resistance of the profession of architecture within the scope of new relations of production will be related mainly to the adaptation and capability of design tools. The great transformation, which the design tools have displayed in the duration of transition from traditional to industrially developed capitalist society, is the only model for the conceptualization of possible changes. Conventional drawing techniques are recently being replaced by computer in professional practice. The consequences of computer use during design and representation processes cannot be conceptualized over existing programs that have not completed their infancy yet.

3.1.1.1. Symbolic Design Tools

In the periods when drawing techniques were not being used, the profession of architecture took its part within the social division of labor as a craft based practice. The architect as a professional was performing his career by applying well-defined spatial and constructional traditions. Thereby, tradition functioned as a design tool with its imposing and transforming influence. Building as a cultural production was shaped by process through which collective values were transferred from one generation to another. In theory, it is not essential to annotate the individual attitudes and preferences under the conditions dominated by traditions. The profession of architecture that used to display esoteric character could be executed without referring any other method except interpretation of rules (Kostof 1992). New architectural styles and building technologies were emerging through a slow evolution process based on the methods of trial and fail. Education of the profession was carried out together with the practice in relations of master and apprentice (Broadbent, 1995). The reason why drawing and other techniques of representation did not turn in to a design tool lies in the fact that the form, order constructional details, structural system of the end product were already known. Because of this reason, drawing had never been a fundamental and pervasive tool earlier than the Renaissance Era.

In the middle ages, when professional practice and training were carried out together, Professional knowledge was not open to the public, even to ordinary professionals. In this age, when construction artisans and stonemasons were organized around guilds, the knowledge was concealed within the organization as a secret

(Broadbent 1995). These guilds that monopolized the information undertook the application of the profession as well as its education. The profession of architecture, which has an esoteric character, could be executed without referring any other method except the interpretation of tradition. Under these circumstances, various construction technologies and architectural forms were altering through a slow evolution process based on the method of trial and error. Thereby, tradition functioned as a design tool with its directing and transforming influence. This design method, which survived for centuries as a valid tool, protected the quality of the architectural object against individual deficiencies and infirmities, although it restricted creativity according to today's criteria. Due to the use of approved building traditions, drawing-based tools were not necessitated within the process of the design and application of a new building. For instance, before the Renaissance period, which constitutes a significant breaking point, architects did not conceive of a whole building and the very notion of scale was not known. Gothic architecture was fundamentally a constructive practice operating through well established traditions and geometric rules that could be applied on site (Perez-Gomez 1997). Nonetheless, it is possible to come across architectural drawings belonging to much former periods of history. For example, the plans of sacred buildings drawn on papyrus in Ancient Egypt and other documents survived till today (Robins 1994). It is possible to find building manuscripts, which were called angraphies and provided communication mostly in construction sites in Ancient Greece. In these verbal documents, the site measurements, the thickness of foundations, sizes of stone blocks details have been described (Kostof 1977). Roman architects used plans, elevations and perspective drawings, dimensioned and colored for their clients (Mc Donald 1977). As a result of an evaluation over existing samples, it is likely to assert that almost all of them served communication purposes. The reason why drawing did not turn into a design tool lies in the fact that the form, geometrical order, details and conceptual diagrams of the end product were already known. Due to these reasons, drawing had never been a fundamental and pervasive design tool before Renaissance. The transformation of design tools in Renaissance stems from the great revolutions in this period. In this age, when there was a break-down in traditions, the belief system was based on new concepts of spiritual and intellectual autonomy of individual on the power of human reason and dependence on supernatural (Trachtenberg and Hyman 1986). Autonomy of the individual had become dominant as from Renaissance, unlike the Middle Age, which was prevailed by strict scholastic thinking supported by conventions. As Jacob

Burkhart states, this age can be defined as a time period, in which nature and individual were rediscovered (Burkhart 1944). The most significant characteristics of the Renaissance thinker, who was continually after new discoveries, can be grounded on learning, discovery, creation and knowledge.

3.1.1.2. Analog Design Tools

The emergence of architecture as a self conscious individual practice is precisely the moment when so called artes liberals gain their ascendancy over the artes mechanical and when the rise of individual architect/artist, as a proto-profession, brings about a corresponding fall in the statue of master carpenter (Frampton 1991). The concept of design as a fairly modern creative and unconventional notion had also appeared in this period. Starting to produce building by making design instead of applying the well defined traditions raised the status of the architect from craftsman to artist. As a matter of fact the architect as artist gets his identity from design based-skills and knowledge. The role of designer which the architect under took by keeping away from building production, is not a task to commit without drawing. Therefore drawing techniques have become a crucial part of professional practice. The invention of new form of drawing like perspective, section, elevation, and plan and axonometric added to the methods by which design was comprehended and the means through which design was created. Drawing-based tools have reached to the necessary maturity since the beginning of the nineteenth century; the development of stylistic language of modern architecture has extended to the first decades of twentieth century. Modern space, with reference to Cartesian coordinates was designed through facilities offered by descriptive set of drawing. For instance representation of neutral space could only be possible by the use of descriptive geometry as a tool by avant-garde movement. It provided an opportunity for a mathematical space, which could be expressed as two- dimensional and without the help of perspective. This opportunity brought in a back ground for modern architecture and was benefited as new-reflexive design medium. In other word it is a tool for reinterpretation and discovery motivated which uses the abstract character of axonometric and orthographic projection.

In accordance with modern conventions, the efficient use of drawing techniques by and architect is of basic importance. It is generally believed that a good architect can

make good designs because he/she can use drawing techniques competently. A designer, who can draw well, is also thought to be able to present his/her creative ideas and product effectively. These ideas which are partly valid in terms of performing the profession form the base of modern educational conventions grounded on heuristic methods. According to Row's opinions the term heuristic refers to a problem solving process, in which it is unknown beforehand whether a particular sequence of steps will yield a solution or not. Consequently, it evolves a decision making process in which we do not know whether we actually have solution until the line of reasoning is completed or all the steps are carried out.(Row 1992). Drawing capability will be of advantage during such reasoning. Hence a special effort is put fort, for all sorts of drawing techniques. Especially in the initial stage of design, freehand techniques that provide thinking have great significance. In this face which a design problem is structured, the key to success is producing rapid and plentiful alternatives. The designer concentrates on comprehending the program on the beginning and generates alternatives by articulating the program in to subgroups (Verstijnen 1998). In this respect, both controlling articulation and producing more alternatives are again directly related with drawing and sketching skills. Appreciation of the orthographic set and axonometric as a design tool initiates the students into operates at Cartesian plane and the use of Euclidian geometry. It becomes impossible to think or represent a work designed by using non-Euclidian geometries even one wish to design. Because of the reasons mentioned above, any educational system that is carried out by conventional drawing techniques in representation of design works inevitably reproduces orthogonal and Euclidian geometries.

3.1.1.3. Digital Design Tools

Digital applications, which first entered the field of architecture as purely a presentation tool, have quickly become its inseparable part. The basic reason that speeded up this process was the parallel development of the spread of appropriate software and communication technologies. These techniques and technologies can alter not only the design and presentation processes but also the manufacturing process and even our modes of communication. This process, which has been self-propagated, has for the time being been reflected in every step of professional practice.

In the field of architecture software technology can be classified in two main groups the first consist of consist of non-graphical, mathematical calculations based basic engineering software. Basic static, illumination, HVAC calculation programs can be thought in this group (Which are out of the scope of this study) Second group, is consist of visualization based complex and specialized software (Yarkan, 2001). This kind of software calculates the necessary information and visualizes them on the screen. Drawing programs such as AutoCAD, ArchiCAD, and modeling and visualization programs such as 3D Studio, Cinema 4D can be suitable examples of this group. All systems and techniques in these groups are generally called Computer Aided Design (CAD) or Computer Aided Architectural Design (CAAD) programs. CAD technology and related software help designers to prepare drawings, specifications, parts lists, and other design related elements using special graphics and calculations. CAD programs are used or a wide variety of products in such a fields as architecture, electronics, and aerospace, naval, and automotive engineering. Although CAD systems originally were merely used for automated drafting at the beginning, at present they usually include tree- dimensional modeling and computer-simulated operation of the model (Akgun 2004).

3.1.1.1.1. Object Based (CAD and CAAD) Programs in Design

In fact the software which is designed for the purpose of architecture is also reproduces the Euclidian geometries. Because, object based computer programs, which are widely used all around the globe, have been designed to respond the needs of the conventional architectural practices. These programs that essentially facilitate for the reproduction of existing space are categorized under the title of computer Aided Design Programs or Computer Aided Architectural Design Programs (CAD/CAAD)They are structured by articulating building components (objects) such as walls, slabs, doors, windows, and roofs. Although they promise great convenience in terms of representation and communication techniques, these kinds of programs should not be considered as new devices. Object-based computer programs can easily be adapted to any kinds of conventional representation technique. They have great advantages in three dimensional representations comparing with conventional drawing activities. They also facilitate the professional practice by assisting the revision on a finished project and multiplying the requiring elements in drawing scales. Even if these computational

applications offer ease, they are not capable of producing alternative to existing architectural vocabulary. There are two reasons for this situation. The first one is that, these software articulate ordinary building components in the virtual medium. Mentioned components are used by conventional architecture and are not eligible to get beyond common design practice. The other reason is they can not undertake an effective role in the initial stages of design when human mind is most active in terms of creativity. This phase in which design decisions are taken, constitutes the stage that alternative production and reflexivity reach the most intensive point. Existing architectural software are not flexible enough at this stage of design. The greatest restriction a designer experiences, while using them is that design problem and alternative solutions can not feed each other, since the feed back between their comprehension and visualization cannot interact.(Willey 2005). Computer aided architectural design programs are mostly utilized after determining design decisions and conceptualization. Due to all these reasons, object based CAD/CAAD programs which are widely used in the field of architecture, bear the characteristics of an advanced drawing board rather than a new design tool.

Starting from the beginning of 1980s, Computer Aided Architectural Design (CAAD and CAD) software is commonly used in architectural applications. As being the most widespread program category, these programs were usually used multi-purpose. For example they have the same interface with other design fields such as structural calculations, electric and mechanical engineering. Autodesk's AutoCAD program is an example of this kind of software. General structure of the AutoCAD program is not peculiar to a specific profession but provided a useful interface for all profession related to design. However at the moment software that is available in the market are specialized programs and interfaces for every discipline. Autodesk's Architectural Desktop, Graphisoft's ArchiCAD, Nemetscheck's Allplan are among examples of this kind of software.

3.1.1.1.2. Solid Modeling and Animation Programs in Design

Even though appropriate software is exceptionally used in the building sector, there are quite a few examples that are realized by making use of computer as a design medium. The formal language of these end products are categorized as 'digital

architecture' and can only be represented by the help of some specific software. By using these kinds of software which are titled as 'animation' and 'solid modeling' programs, it is possible to operate with non-linear geometries while defining them as vectors. Computer aided modeling (CAM) applications also undertake production that is impossible to produce by the use of conventional production or construction techniques. So that mentioned programs provide means which make possible to produce alternative spaces and solids different than offered by CAD or CAAD programs and descriptive set of drawing.

Animation programs are transferred from film industry. They are developed for the purpose of producing all sorts of film effects, motion pictures and animation films. They are also designed for the use of multi-media studies. But they are rapidly invented by architects as a revolutionary design tool that is able to change their professional practice. They bring a new dimension to cognition of space. Solid modeling programs on the other hand, serve several design and modeling prospects including primarily the industrial objects. These programs enable the production of geometric forms and spaces without depending on Cartesian plane. In addition, they produce creative images without relying on imitation of real objects. In most of the cases a single program embodies the features of these two kinds of programs. Architectural applications of these kinds of software, single or composite results with the creation of a new space that is different from common space types. Because in conventional architecture, the abstract space of design is conceived as an ideal neutral space of Cartesian coordinates. In digital architecture however, design space is conceived as an environment of force and motion rather than as a neutral vacuum. For example the abstract space of design is imbued with the properties of flow turbulence viscosity and drag. Computer programs relied on topologic operations, are used in order to transform motion in to space. Solid modeling programs can perform stretching operations on surfaces. Further more they can also compose initiative surfaces as well as lines with multiple curvatures that are formed by processing curves. Due to these peculiarities, mentioned programs transfigured Cartesian coordinates in to topologic operation. Computer aided topological design techniques create curvatures that is a mode of integrating complex entities in to a complex form. The use of this software for the design of form requires a more abstract and often less representational origin of design. The term abstract here implies a shift from modernist notion of abstraction based on form and vision to an abstraction based on

process and movement (Lynn 1999). Therefore, digital representation tools and processes, (re)defined through these developments, are transforming and reforming the conventional architectural representation process. Raised parallel to the dynamic and responsive character of the current and near-term life-styles, architectural representation also witnesses a transformation from a static relationship between idea and image, towards a more dynamic process (Mitchell 1995). With a tendency to deal more with process rather than form, the altered architectural design process is numerically hosting this process in all phases of design and consciously delays its visualization (Uçar 2006).

Digital architecture not only establishes new aesthetic norms and design practice but also leads up to elimination of the distance between architecture and craft. Because of the craft based, empiric attitude of pre-modern practice of architecture, there were not need to representational techniques. The interrelations between architecture and craft had ceased by the domination of industrial production on the construction sector. These connections are re-establishing by the newly developing technologies such as; rapid prototyping (RP), computer aided manufacturing (CAM), digitally controlled on site positioning and software driven sheet materials. By the help of these manufacturing technologies traditional constructional documents are not just automated but eliminated (Mitchell 2000). New fabrication technologies put forward the concept of mass customization against the existing paradigm of standardization. This kind of production mode enables production of non-standard building components that are digitally controlled. In other words it provides mass production of building components which are generated by the generic diversification. This method also provides cost efficiency same as industrially produced ordinary building components. All of the facilities mentioned above transforms nature, articulation and connection of building material and extends the variety of construction market. Experimental use of composite materials, plastic, metal and glass in the sector proofs this trend. Digital architecture as being produced its implicit norms, design tools and production mode seems to be set up a new era in the field of architecture.

3.2. Digital Fabrication and Rapid Manufacturing in Construction

At the beginning digital architecture that refused to be materialized was an architectural category of spatial experiences. But as the time passing, architects noticed that by the help of technology transfers from the other sectors such as shipping, air plane, automotive industries, it was possible to construct buildings with highly curvilinear surfaces. In other words complex surfaces in digital architectures brought to the front the question of how to work out the spatial and tectonic consequences of such non-Euclidean forms. It was the issue of constructability that brought into question the credibility of spatial complexities introduced by the “digital” avant-garde. Because construction sectors that organized around standardized fabrication methods was not able to answer the needs of the digital architecture. Besides this it was almost impossible to manufacture such as complex forms even they are geometrically defined as vectors in Cartesian space. However, the fact that the topological geometries are precisely described as Non-Uniform Rational B-Splines (NURBS) and thus computationally possible to design, also means that their construction is perfectly attainable by means of computer numerically controlled (CNC) fabrication processes, such as cutting, subtractive, additive, and formative fabrication, which are briefly described in this part of the present study. What makes NURBS curves and surfaces particularly appealing is their ability to easily control their shape by interactively manipulating the control points, weight and knots. Figure 3.1 shows development of NURBS and similar curvature by Cartesian methods (composite curves). They made heterogeneous yet coherent, forms of digital architectures computationally possible and their construction attainable by means of numerically controlled (CNC) machinery. (Kolarevic, 2003).

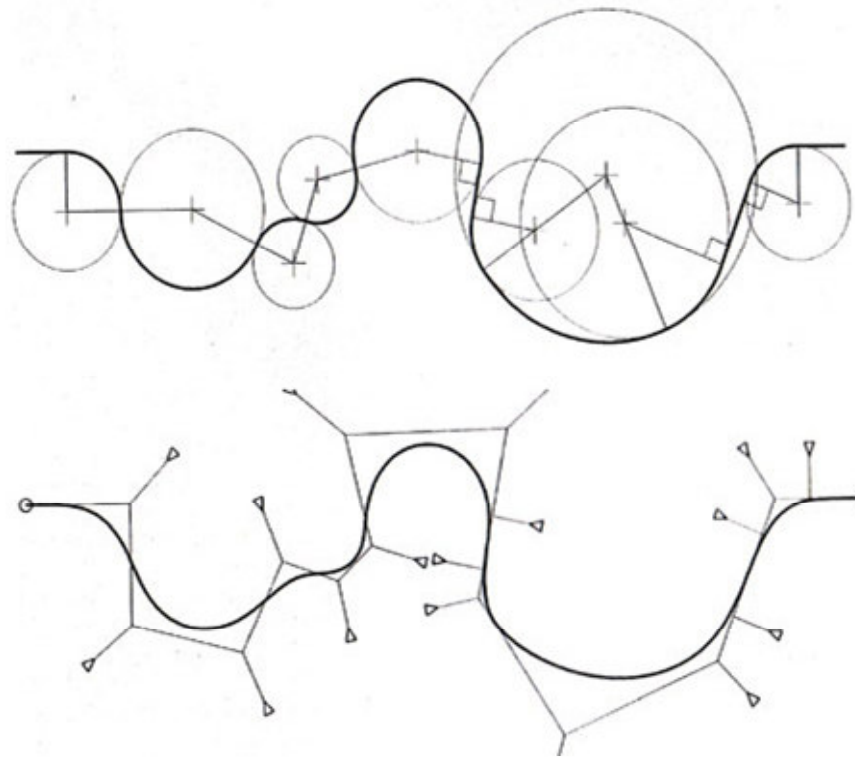

Figure 3.1. Example of composite curve and similar curve described by using spline geometry (NURBS) (Source: Kolarevic 2003).

3.2.1. Digital Fabrication Methods

Digital Fabrication is a new field of study formed from a need to obtain a method to use in computation and numerically controlled processes of design. Relationships between fabrication and computation build a relationship between design and materials at all levels of digital fabrication. Computer Aided Manufacture (CAM) systems can be called under the name of Rapid Manufacturing, Rapid Prototyping, Solid Freeform Fabrication, Additive Manufacturing etc depending on the country or applied machinery. All of these systems which can be categorized as CAM systems were originally developed in aero space industry. Rapid Manufacturing has come through an evolution. Early versions could not produce robust components that could be classed as ‘end-use’ parts and this was largely down to the quality of the materials. Materials development plays a key role in realizing true functionality in parts produced using Rapid Manufacturing technologies. Highly engineered components, such as camshafts, gearboxes, etc., can be manufactured using CAM processes. The aim of all these computerized methods, were quickly produce prototype models. The name Rapid

Prototyping described the time saving associated with the negation of the human modelers, or tool maker employed to create the object for evaluation as part of the design process. Rapid Manufacturing is the term applied when Rapid Prototyping machines are used to produce end use parts directly.

Today all most every manufacturing activity is realized by using Computer Numeric Control (CNC) machinery. Digital fabrication methods based on CNC applications use CAD data as digital input to shape the raw material. In fact these apparatus appear in aviation industry first, later develop in automotive industry. Developments in mechanical and electronic possibilities, such as microprocessors, linear movement engines; developments in computer hardware and software are some of the factors of this radical change in production systems. The Turning table or similar apparatus in analog system needs a 'human touch' to transfer the design from drawing to the material. But in digital system the design transfers as a numeric data to the production process.

All of the CAM processes work on similar principles depicts the 3D printing process. A 3D solid model of the desired component is created in CAD software. The model is then typically translated into Standard Triangulation Language (STL), a standard data format that can be used by most Rapid Manufacturing machines. This describes the surface of the object and can then be 'sliced' into layers so that the part can be constructed sequentially. Each layer is then sent to the machine and the information used to control the location of a printer head. The printer head deposits a binder on a fine layer of powdered material where the layer is to be made solid. The machine reconstructs a 3D object by sequentially bonding these '2D' layers of material (Buswell 2007).

Opposite to its name Rapid Manufacturing process has not relationship with speedy production but abolition of human error. In fact, it easily eliminates the need for tooling and so shortens time to manufacture. In practice where a high degree of customization is not the principle driver, Rapid Manufacturing can still be cost effective. While conventional mass production remains economical for large batches of like components, Rapid Manufacturing has been shown to have the potential of reducing production run costs for low volumes of products.

It is possible to classify the digital fabrication methods under four different headings as done by Kolarevic, Buswell, Soar, and Gibb. These are Lateral Countering Fabrication (Two Dimensional Fabrication), Subtractive Fabrication, Additive

Fabrication, Formative Fabrication. CNC machines that operate in different axis is common points of these methods. The capacity and the material used the It is also necessary that all these methods are used in construction sector as well.

3.2.1.1. Cutting Methods (Lateral Countering)

CNC cutting, or 2D fabrication, is the most commonly used fabrication technique. In this production method, the product components are reduced to distinct but alike planer elements. These planer elements are usually connected to each other by using conventional connections such as bolting or welding. Reduction of curved surfaces into two dimensional planes is one of the basic working principles of digital modeling. In fact this is the only way to define a curve as vectors in coordinate system. By so doing the curves can geometrically be defined by a limited number of vectors. This geometrical description method which is called as “triangulation” or “polygonal tessellation” of geometrical forms also provides transformation of double curvature surfaces into simple triangles. Materialization of digital architecture was firstly inspired from this feature of software. As it is known, all of the modeling software works with this principle. Similar methods are used in manufacturing process. The order that is assigned by computer to CNC machinery is a version of its geometrical definition in a different scale.

Various cutting technologies, such as plasma-arc, laser-beam, or water-jet, involve two-axis motion of the sheet material relative to the cutting head and are implemented as a moving cutting head, a moving bed, or a combination of the two. In plasma arc cutting an electric arc is passed through a compressed gas jet in the cutting nozzle, heating the gas into plasma with a very high temperature, which converts back into gas as it passes the heat to the cutting zone. In water jets, as their name suggests, a jet of highly pressurized water is mixed with solid abrasive particles and is forced through a tiny nozzle in a highly focused stream, causing the rapid erosion of the material in its path and producing very clean and accurate cuts. Laser cutters use a highly intensity focused beam of infrared light in combination with a jet of highly pressurized gas(carbon dioxide) to melt or burn the material that is being cut. The production strategies used in 2D fabrication often include contouring, i.e., sequential sectioning (Figure 3.2.), triangulation (or polygonal tessellation), use of ruled,

developable surfaces, and unfolding. They all involve extraction of two dimensional, planar components from geometrically complex surfaces or solids comprising the building's form. Which of these strategies is used depends on what is being defined tectonically: structure, envelope, a combination of the two, etc (fig 3.2.) (Kolarevic 2005).

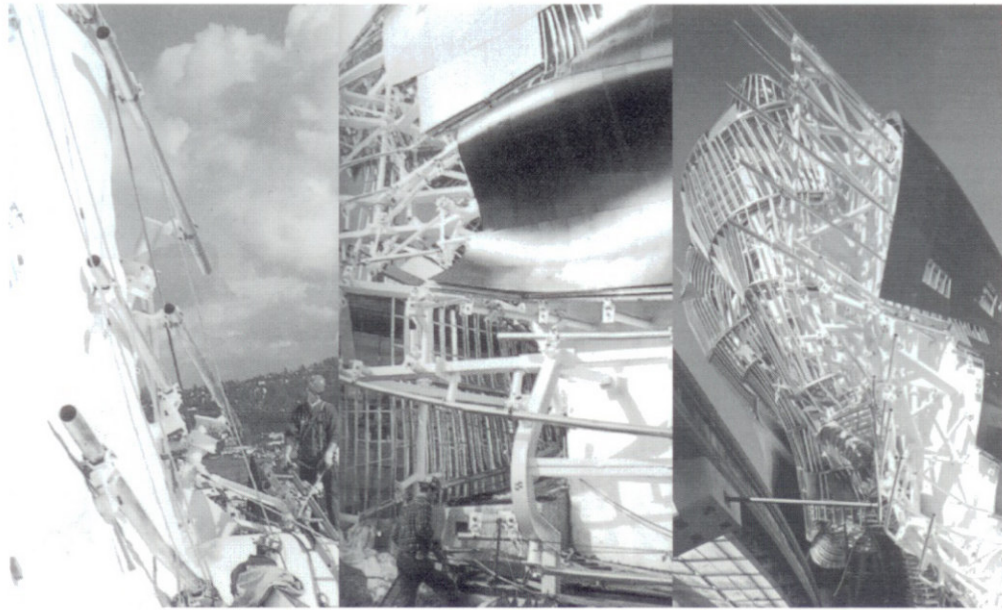

Figure 3.2. Frank Gehry, Experience Music Project
(Kolarevic 2005)

Even their functions seem to be similar there are large differences between these technologies from many point of view. For example, material and maximum thickness can vary from each other. While laser cutters can only cut materials that absorb light energy and 16 mm. thickness, water jets can almost cut every material up to 40 cm.

3.2.1.2. Subtractive Fabrication

As its name implies, subtractive fabrication involves removal of specified volume of material from solids using multi-axis milling. In CNC (Computer Numerical Control) milling a dedicated computer system performs the basic controlling functions over the movement of a machine tool using a set of coded instructions. In this kind of technology electro-chemically or electro-mechanically reductive processes are operated. In axially constrained systems such as lathes material that is engraved has one axis of

rotational motion and milling head has two axis of trans-rotational motion. Whereas surface constrained milling machines, are conceptually identical to the cutting machines mentioned above. In two axis milling routers the rotating drill-bit is moved along X and Y axes to remove two dimensional pattern of material. As the geometry complicated a four or five axis machines are used. In this way, the cutting head can perform the under cuts and can perform under-cuts and can substantially increase the range of forms.

The material which is subtracted and used for formwork can be made of any material that can be engraved. It is expected to provide uniform surface quality. Resistance against external forces, during molding process is also an essential feature of the material used for the form work. Most commonly used materials are Styrofoam, Wood, PVC Blocks, Acrylic Thermosetting Plastics, and Stucco. But it is necessary to not that only some of these materials are used in building construction. Because of the low cost some of them are widely use in construction works. For example, Styrofoam molds can be use for the casting of reinforced concrete. Stucco is another alternative material for subtraction material that can meet the requirements of formwork. It is also used in interior space organizations. However, PVC blocks are expensive materials for formworks in large scale. It is also important to not that the formworks are conducted by conventional methods and technologies except the data transmission and carving process. Even if treatment of material changes under the influence of digital technologies, conventional processes such as mock up are applied.

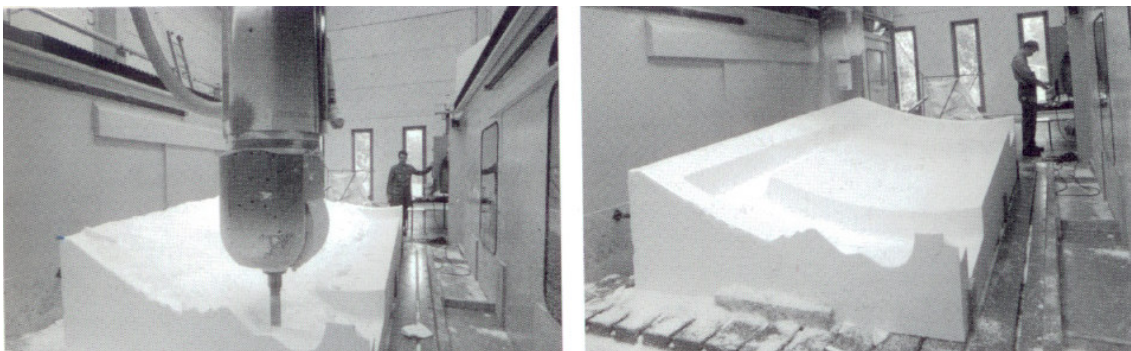

Figure 3.3. Mock-up process
(Source: Kolarevic 2005)

This decades old technology has been recently applied in innovative ways in building industry, to produce the formwork (molds) for the off-site and on-site casting of concrete elements with double curved geometry, as in Gehry's office buildings in

Düsseldorf, Germany (Figure 3.4)., and for the production of the laminated glass panels with complex curvilinear surfaces, as in Gehry's Conde Nast Cafeteria project and Bernard Franken's BMW pavilion (Kolarevic 2005).



Figure 3.4. Gehry, Dusseldorf Office Building
(Source: Kolarevic 2005)



Figure 3.5. Gehry, Conde Nast Cafeteria
(Source: Kolarevic 2005)



Figure 3.6. Franken, BMW pavilion
(Source: Kolarevic 2005)

3.2.1.3. Additive Fabrication

In a process converse of milling, additive fabrication (often referred to as layered manufacturing, solid freeform fabrication, or rapid prototyping) involves incremental forming by adding material in a layer-by-layer fashion. The digital (solid) model is sliced into two-dimensional layers; the information of each layer is then transferred to

the processing head of the manufacturing machine and the physical product is incrementally generated in layer-by-layer.

Since the first commercial system based on stereolithography was introduced by 3D systems in 1988 a number of competing technologies has emerged on the market utilizing a variety of materials and range of curing processes based on light, heat or chemicals (CHUA, 1997). stereolithography (SLA) is based on liquid polymers that solidified when exposed to laser light. A laser beam traces a cross section of the model in a vat of light sensitive liquid polymer. A thin solid layer is produced in the areas hit by the laser light. The solidified part, which sits on a submerged platform, is then lowered by a small increment in to the vat, and the laser beam then traces the next layer, i.e. the cross section of the digital model. This process is repeated until the entire model is completed. At the end of the process, the platform with the solidified model is raised from the vat, and the model is than cured to remove extraneous liquid and to give a greater rigidity (Kolarevic 2003).

The constrained size of the objects that could be manufactured, costly equipment, and lengthy production times, enables the use of additive methods in some sectors such as construction works. That's why the additive fabrication processes have a rather limited application in building design and production. In design, they are mainly used for the fabrication of (massing) models with complex, curvilinear geometries. In construction, they are used to produce components in series, such as steel elements in light truss structures, by creating patterns that are then used in investment casting.

It is necessary to note that several experimental techniques based on sprayed concrete are introduced recently. By this way, manufacture of large-scale building components can be produced by using digital data. This method that is called contour crafting allows comparatively faster fabrication of layers. The method which was design to fabricate building components organized around a hybrid automated process. Extrusion of surface and filling process based on pouring is combined. Outside edges of each cross-section on each layer are shaped by computer-controlled trowels that are then filled with concrete or other infill material such as concrete or polymers. In this method, composition of material can accurately be added by digital machinery. So that material composition becomes extremely reliable.

3.2.1.4. Formative Fabrication

Formative fabrication methods are realized by applying various forces to the material. For example application of heat or steam is one of the most common formative systems. Beside this, mechanical forces can be applied or the form can be restricted so as to form it into the desired shape through reshaping or deformation. Here the forces can be axially or surface constrained. For example, the reshaped material may be deformed permanently by such process as stressing metal past the elastic limit heating metal and then bending it while it is in a soften state, steam bending boards etc. Double curved compound surfaces can be approximated by arrays of height-adjustable, numerically-controlled pins, which could be used for the production of molded glass and plastic sheets and for curved stamped metal. Plane curves can be fabricated by the numerically-controlled bending of thin rods, tubes or strips of elastic material, such as wood (Kolarevic 2003).

3.2.2. Digital Fabrication and Rapid Manufacturing in Construction Sector

In terms of technological development and fulfillment of customer expectation, Technology transfer from other fields of manufacture is common trend in the field of construction since the beginning of the industrial age. It can be argued that construction is decades behind other industries such as aerospace, automotive and ship building. But the fundamental principles of construction have not changed for hundreds of years; the Romans invented concrete about 100 BC and 2200 years later we are still using it as a primary build material and (more or less) controlling placement with the human hand. Construction technologies are limiting imagination and hence stifling innovation; new methods of production and assembly often result in moving the ‘hand trades’ away from the construction site rather than developing radical new processes. Often the procurement and legal requirements that enable construction act as a disincentive to try different approaches.

Competition for projects concentrate on first-cost; the cheapest bid wins and there is little time, money or energy to invest in innovation. The industry is also conservative and innovations only generate incremental changes. Where changes and

improvements are made, the transient nature of the work and workforce often means that these improvements are not adopted on new projects as they might in a more 'static' manufacturing environment. There is a growing skills shortage, which will be compounded in the future by the aging population apparent in the developing and alike countries. Safety is still an important issue; construction remains a hazardous environment. In addition, the industry is likely to face increasing pressures from developing environmental issues (Guthrie 1999). Process automation offers a large departure from conventional methods of construction. This has largely been investigated in terms of robotics. Creating large scale 'on-site factory' environments have been demonstrated by the construction of many new buildings.

The common applications of CNC manufacturing in construction are cutting processes used to form structural steel members and milling processes employed to create large moulds from polystyrene for casting concrete or shaping glass. Gehry's Zollhoff Towers (Dusseldorf, Germany) used CNC techniques in the manufacture of major structural components. The towers are three blocks of offices, each made up of a series of 'twisted' and 'warped' rises in which every wall panel is curved. One set of offices is finished in metal, one painted and one in brickwork. CNC Plasma-arc cutting of sheet steel was used to form the masonry supports. The load bearing, curved, external wall panels were produced using blocks of lightweight polystyrene and CNC machined to produce hundreds of different curved moulds that became the forms for casting the reinforced concrete (Busswell 2007).

Generally two-dimensional fabrication is used in building construction, including contouring, triangulation (or polygonal tessellation) ruled developable surfaces, and unfolding. All of these methods are developed by extracting geometrically complex planes from two dimensional planes. By aligning these complex forms it is expected to handle geometric approximation that will preserve the essential qualities of initial tree-dimensional space. Which of the production strategies is used depends on what is being defined tectonically: structure, envelope, a combination of two. In commonly realized applications, sequence of irregular sections often parallel to each other are placed at regular intervals as seen in the next figure.

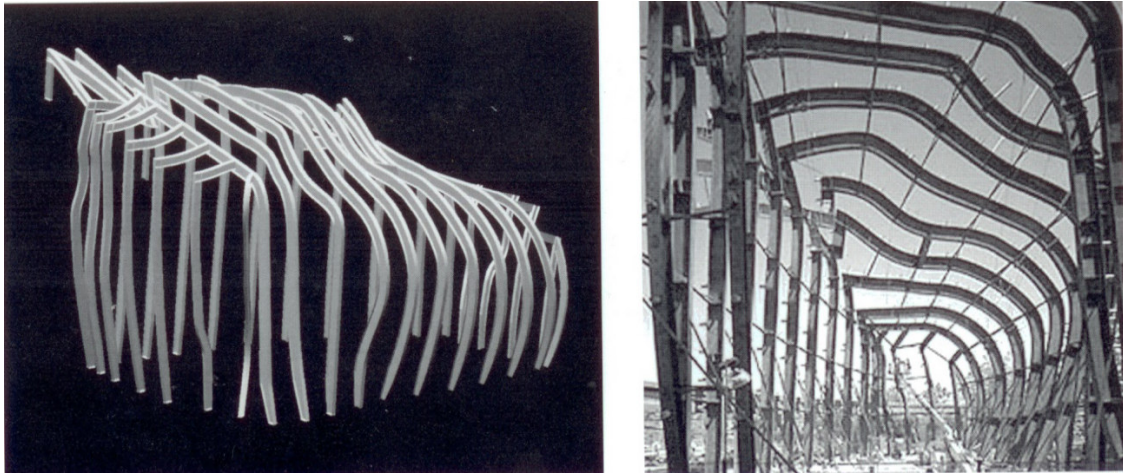

Figure 3.7. Structural Frames in Gehry's Experience Music Project
(Source: Kolarevic 2005)

The wire frame cross sectioning is another way of digitally driven construction. Building's structural frame is manipulated to create a complete abstraction of the building. By so doing a precise definitions of structural members are generated. For example in some specific software generate a comprehensive digital model for structural steel, including the brace-framed and secondary steel structures as can be seen in the Ghery's Bilbao Project. In this project same specific program called as Bocad was used to produce fabrication drawings, or CNC data, to cut and pre-assemble the various components (Lecuyer 1997).

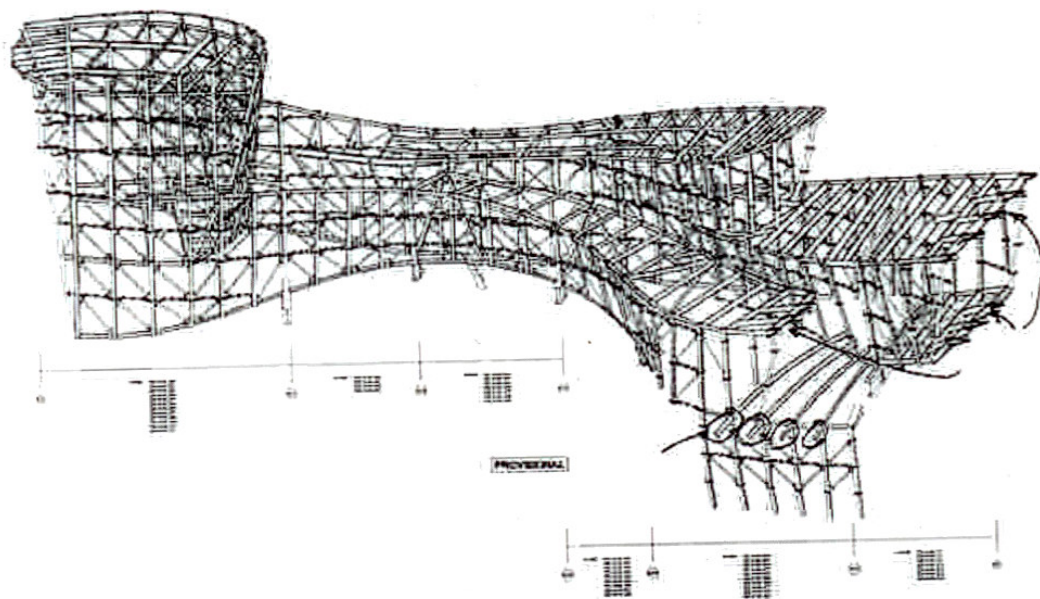

Figure 3.8. Bilbao Museum, Steel Detailing software
(Source: Kolarevic 2005)

Another fashion of digital construction is the combination of counterering technique with extraction of the isoparametric curves used to aid in visualizing NURBS surfaces through counterering. For example the tubular members of BMW pavilion designed by Bernard Franken for the Auto show in Geneva, featured CNC-formed, doubly curved geometry extracted as isoparametric from the complex surface.

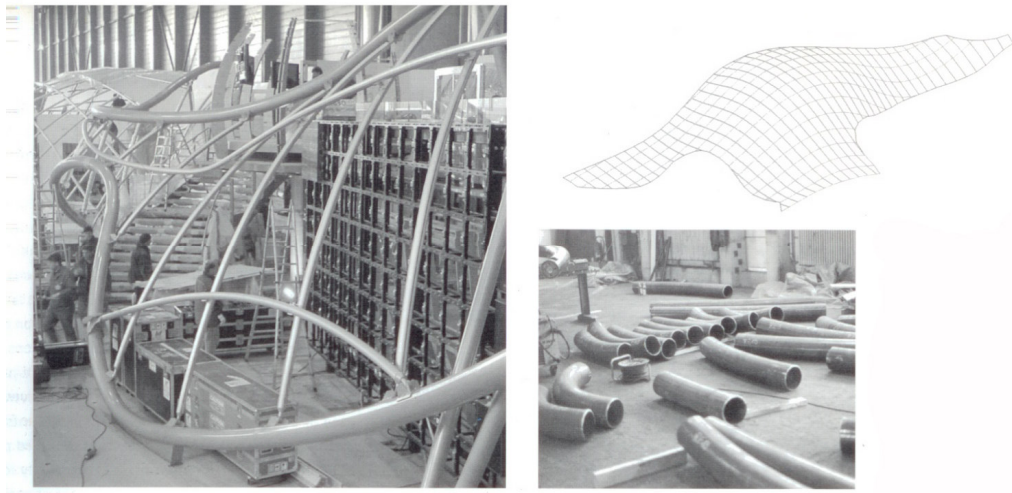

Figure 3.9. Franken, BMW pavilion
(Source: Kolarevic 2005)

Triangulation is the most commonly applied form of planer tessellation. It was used for example in the glass roof of the DG Bank building the triangulated space frame was constructed from solid stainless steel that Ghery designed at Parizer Platz in Germany. The triangulated space frame was constructed from stainless steel rods that meet at different angle sat six-legged star shaped nodal connectors, each of which was unique and was CNC cut. A similar production strategy was used in glass roof of the Great Court in British Museum in London, designed by Foster and Partners. The irregularly shaped and deformed sliced torus form of the roof was rationalized as a triangulated frame network consisting of 4878 hollow rods and 1566 connector nodes, all of them different from each other and all o them CNC cut. The frame was then filled with 3312 glass panes, each of which was unique, due to the irregular geometry of the roof's perimeter (Kolarevic 2003).

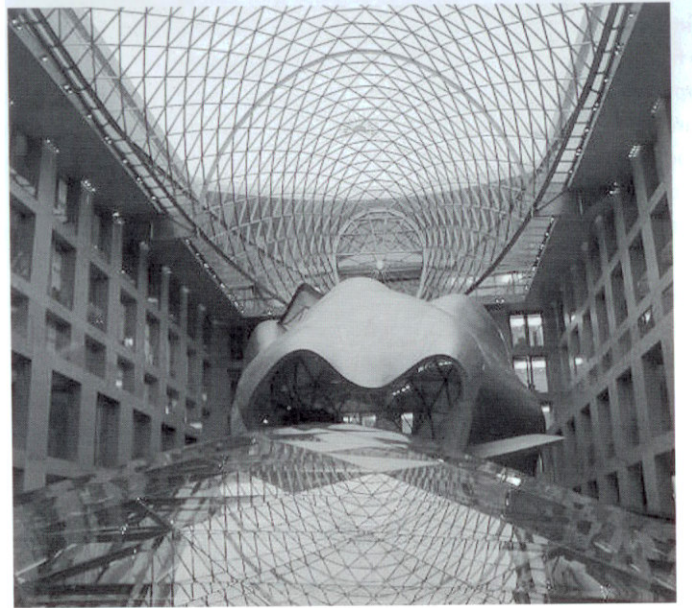

Figure 3.10. Triangular Geometry
(Source: Kolarevic 2005)

It is sure that ruled surfaces are one of the most pervasive methods of digital applications because they can be developed i.e. unfolded in to flat shapes in modeling software and digitally fabricated out of flat sheets. Unlike the double-curvature NURBS surfaces ruled surfaces are curve only in one isoparametric direction. Developable surfaces can be formed by rolling a flat sheet of material without any deformation.

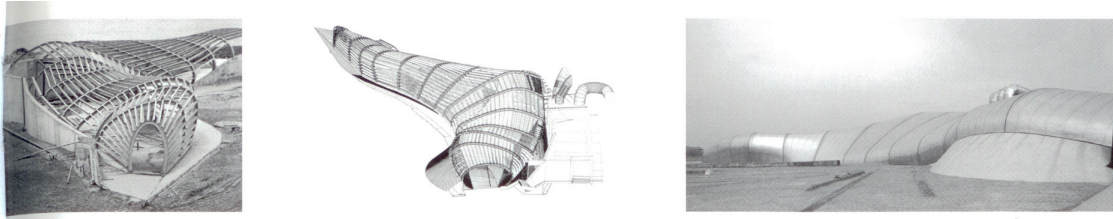

Figure 3.11. Lars Spuybroek, Water pavilion
(Source: Kolarevic 2005)

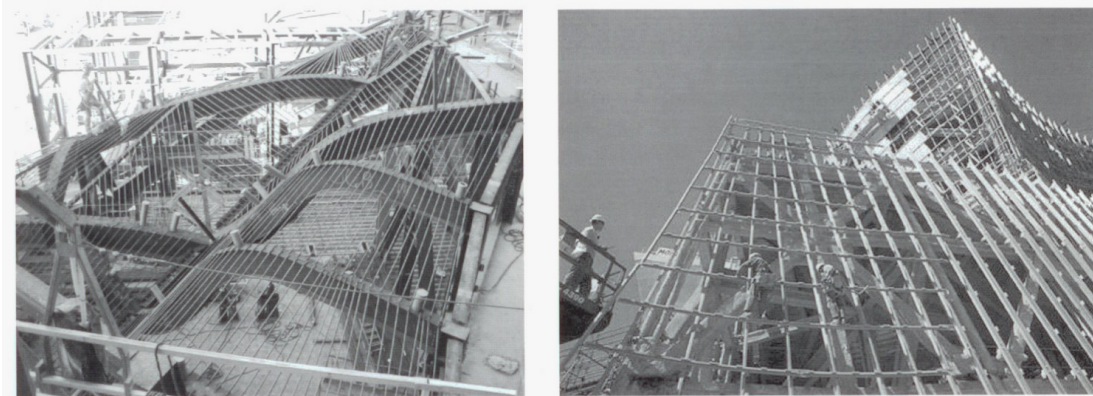

Figure 3.12. Use of ruled surface
(Source: Kolarevic 2005)

A recently developing method of digital applications in building construction is doubly –curved concrete elements formed in CNC mills. In this system, Styrofoam is carved for formwork. Frank Ghery’s Dusseldorf office building called Zollhof Towers is constructed by this way and pioneered the system. Beside structural applications other building components such as glass panel with complex curvature can be produced by this method by heating the flat sheet of glass over CNC milled molds in high temperature ovens. For example the large stainless steel plates (2 m x 4m) for the conference chamber of the DG Bank building, designed by Ghery were shaped by boatbuilders to produce its complex doubly-curved form.

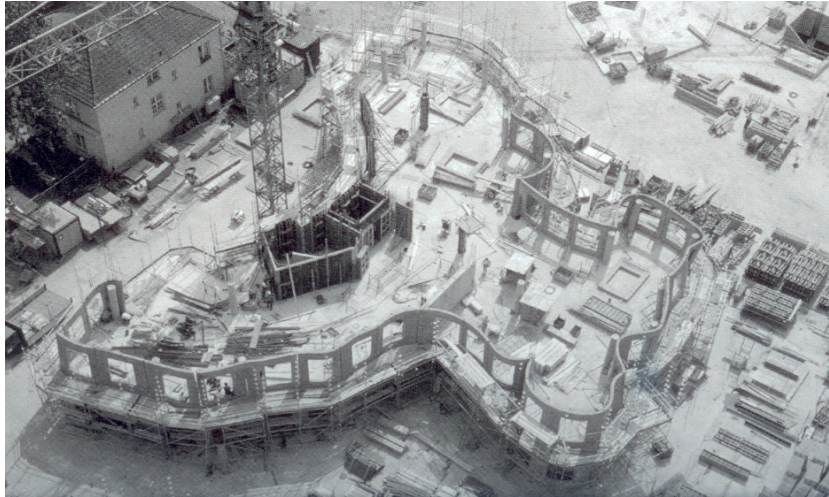

Figure 3.13. Gehry's Zollhof Towers
(Source: Kolarevic 2005)

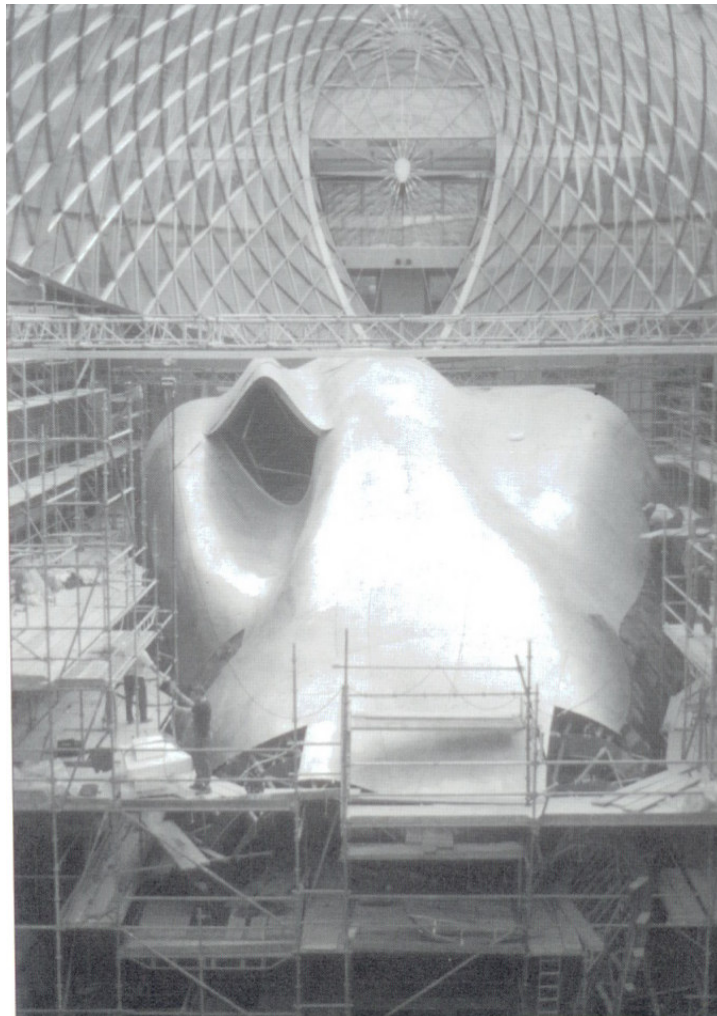

Figure 3.14. Gehry's DG Bank
(Source: Kolarevic 2005)

3.2.2.1. Digital Cladding and Surface Treatments

Recent developments in digital technologies have provided new alternatives for architects. These options are not only limited with new aesthetic qualities but also manipulate new tectonic and structural challenges. The Non-Euclidian geometry inherited by NURBS operations are mostly emphasized in the surfaces of digitally designed and constructed buildings. The exterior surface not necessarily the structure as can be seen Peter Cook's Graz Project becomes the most intricate and specially constructed part of the whole. That's why surface tectonic and its constructability of geometrically complex projects are a matter of discovery. Classification of diverse surface strategies can be seen in the following parts of the study. This classification that was realized by Kolarevic by considering surface and structure relationships in digitally-driven cladding applications. It is also necessary that each of the following approaches to skin and structure is perfectly valid and each has different repercussions for development of the project relative to its over all cost and spatial qualities.

A. Unifying the Envelope and Structure: The search for constructability of complex building envelope has led to a thinking of surface tectonic. From this point of view the digital architecture is different than modernist tectonic and structural thinking. In other words reunifying attempts of the skin and the structure in, opposition to modernist understanding of surface and structure that can be separated from each other differentiate digital avant-gardes from modernists. According to Kolarevic, in digital architecture, the structure becomes embedded or subsumed into the skin, as in semi-monocoque or monocoque structures, in which the skin absorbs all or most of the stresses. The principle idea is to conflate the structure and the skin into one element, thus creating self supporting forms that require no armature. That, in turn, prompted a search for new materials, such as high temperature foams, rubbers, rarely use in building industry (Kolarevic, 2003). Giovannini expresses similar ideas by saying, the following words. The idea of a structural skin not only implies a new material, but also geometries, such as curves and folds that would enable the continues skin to act structurally obviating an in dependent static system: the skin alone does not heavy lifting (Giovannini, 2000). This leads to new relationship between material and geometry of the buildings. For example Kolatan's Raymond House addition is a good example of this briary binary condition. Building because of its geometric attitude is to

be made of polyurethane foam sprayed over an egg-crate plywood armature that should be CNC cut the resulting monocoque structure is structurally self sufficient as seen in the next figure.

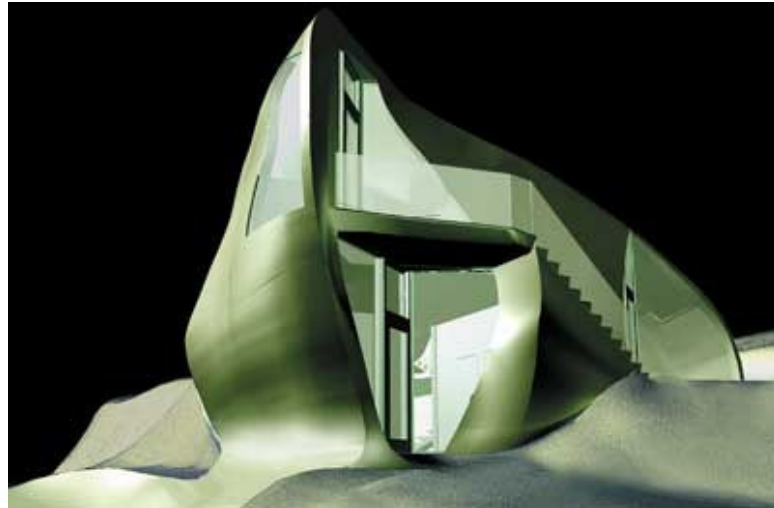

Figure 3.15. Kolatan Raybould House Addition
(Source: Kolarevic 2005)



Figure 3.16. Future System, Nawest Media Center
(Source: WEB_3)

The implications of these new structural skins are significant, as noted by Joseph Giovannini, because they signify radical departure from Modernism's ideals: In some ways the search for a material and form that unifies the structure and skin is a counterrevolution to Le Corbusier's Domino House, in which the master separated the structure from the skin. The new conflation is a turn to the bearing wall, but one with freedoms that Corb never imagined possible. Architects could build many more exciting buildings on the Statue of Liberty paradigm, but complex surfaces with integrated structures promise a quantum leap of engineering elegance and intellectual satisfaction (Giovannini 2000).

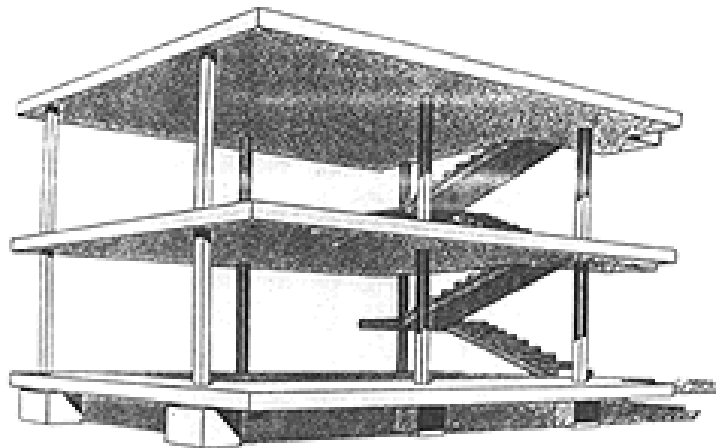

Figure 3.17. Le Corbusier, Domino House
(Source: WEB_6)



Figure 3.18. Statue of Liberty
(Source: Kolarevic 2003)

B. Offsetting Structure Method: Offsetting method is more frequently applied method than the method mentioned above. This method that seems less radical evolves offsetting the structure from the skin into its own layer. From this perspective on, it exhibits similar characteristics with conventional cladding applications. In conventional approaches cladding is supported by the structure itself. The dissimilarity between conventional and offsetting method arises from starting stages of cladding process, in digital applications however, cladding the surface starts from the skin goes towards the structure. Skin supported frames are used in other sectors. For example, the process of working from the skin to the structure is a common practice in automotive and aerospace industries, where the spatial envelope is fixed early on. Such an approach is novelty in architecture a clear departure from the “primacy of structure” logics of the Modernism.

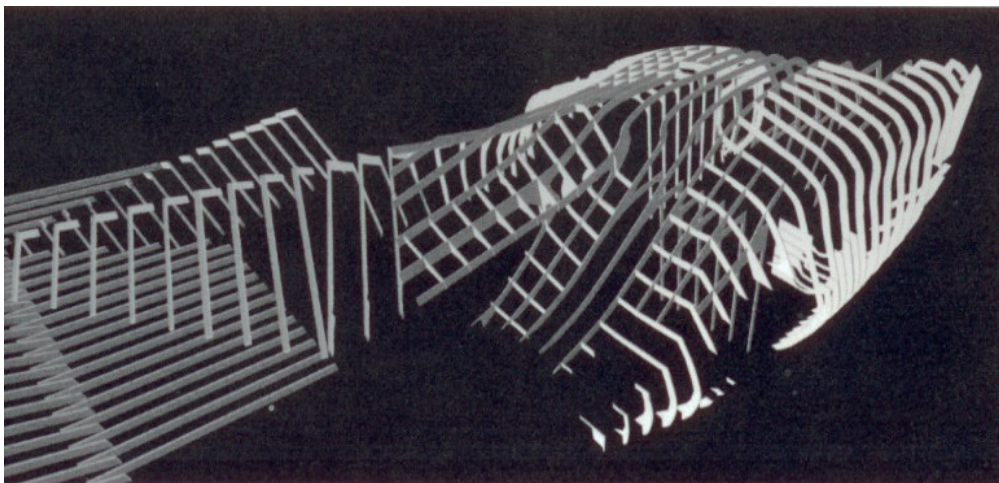

Figure 3.19. Kolatan, Raybould house
(Source: Kolarevic 2003)

Another approach is a distinct separation of the skin and the structure, where the spatial juxtaposition can produce potent visual interplays. Example of this approach can be seen in the statue of Liberty, New York. The juxtaposition of skin and the structure open up alternatives for space arrangements.

C. Conventional Approach: Conventional approach in which the sinuous building envelope is attached to a conventionally conceived structural grid, which if, carefully applied can produced interesting results. For example Norman Foster’s apartment block is a good example of this attitude. In this project the designer applied a complex NURBS surface into a conventional building structure. It is also necessary to

not that building structure because of the functional necessities of multi-floor domestic architecture is expected to be with in the restrictions of Euclidian geometry.



Figure 3.20. Foster's Albion Riverside
(Source: Kolarevic)

CHAPTER 4

CASE STUDY

To see the possibilities of building production in changing relations in design and construction process, a case study has seen necessary. In this case, the possibility of transferring the digital design data to the production process for a conventional housing block cladding seems an important experience. Beyond the special and high cost solutions, to develop appropriate alternatives to the conventional methods is field of study.

4.1. Definition of the Selected Project



Figure 4.1. Emblem of the building

The project which chosen for the case study is a large scale housing block in Çiğli. The plot was some handicapes at the beginning of design study. Triangular shape of the plot was not appropriate to locate a usual rectilinear and orthogonal housing block. To employ a radial plan organisation gave an opportunity a maximum range of street façade and rich perspectives for the housing units. A 100 meters radius at the front façade creates the main curvature of the building. Along the hight of the building,

to create a dynamic effect some recessions was designed. To control that kind of changes some increments and axial regulations was employed.



Figure 4.2. Perspective view of the building

During the design studies main elements of the building character was excepted as the continuous parapeths of the front balconies. To search for different material and visual effect was focused on balcony parapeth coverings. Present alternatives in the market are mainly metal layered composite sheet which called as Alucobond (a trade mark) or conventional plaster and paintings with different texture effects or some glass or ceramic tiles in different dimensions and color. Sheet covering systems such as Alucobond is widely used in commercial examples because of the fine and shiny effects. They creates a high-tech building illusion. Cladding details are clear and simple. But Minute details are not so perfect because of the bending process in construction. Sharp corners are not suitable for human touch. Other conventional methods such as plastering need a complicated workmanship.



Figure 4.3. Rear View

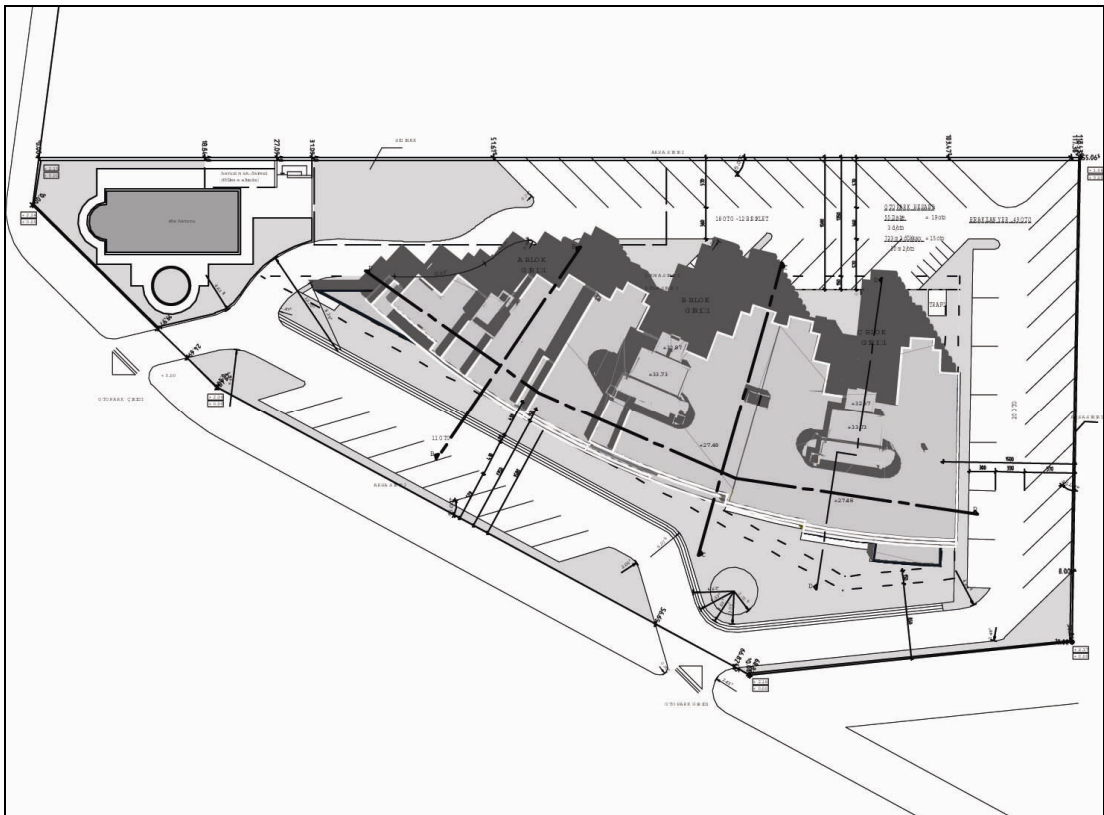

Figure 4.4. Site plan

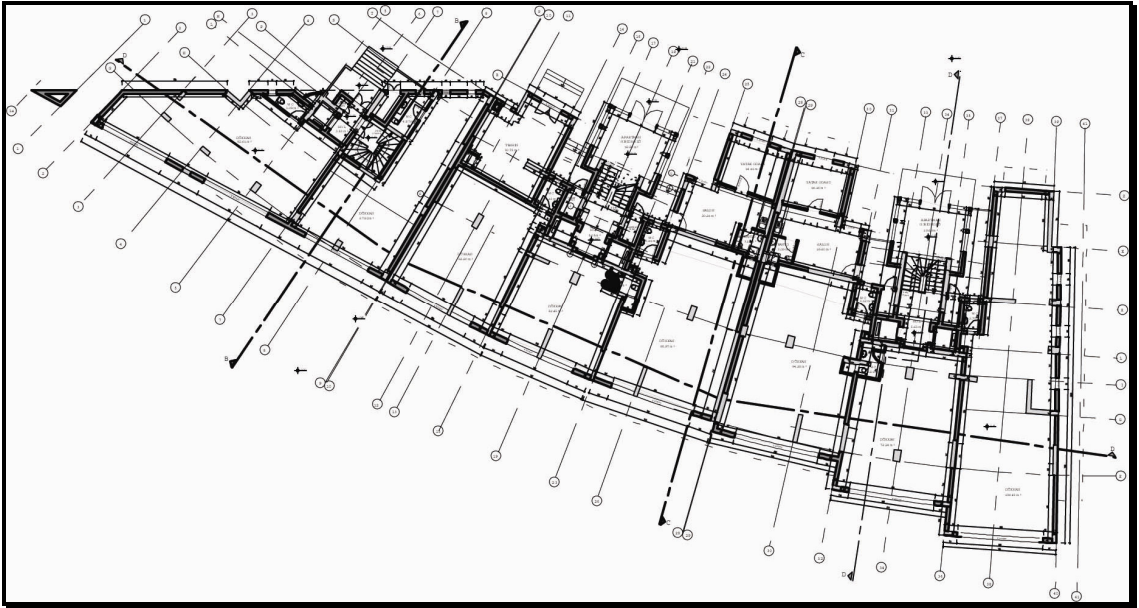

Figure 4.5. Entrance floor plan



Figure 4.6. Typical floor plan

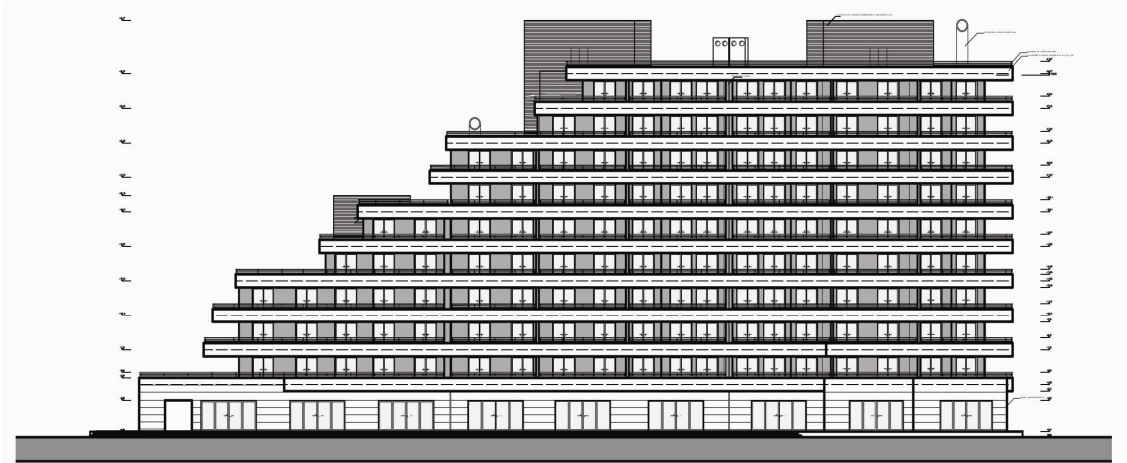

Figure 4.7. Front façade

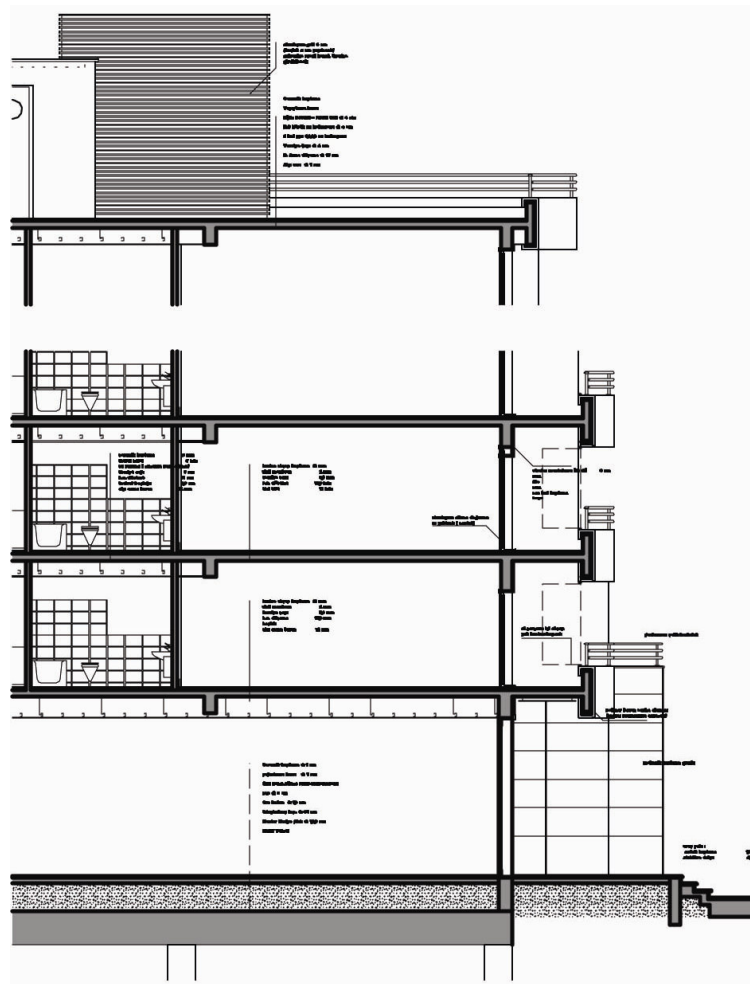

Figure 4.8. Partial section

4.2. Restrictions and Objective

The main objective of this case study is to search for relations of CAD and CAM process to produce appropriate building components. The ability of usage the digital data in production process with low cost and simple workmanship is the key point of the study. Material design is also a primary aspect for this kind of study. In this study, beyond the production process material design is also subjected to search. But, it is necessary to determine that material design needs a more complicated search. Chemical structure of the polymers and mechanical behavior of the different composites have a large amount of theoretical and experimental knowledge. The economic and environmental aspects of material design are another face of material design. The limits of this study must be drawn as design of façade cladding elements as CAD and CAM transitions for ordinary construction works. The economic aspects of must be concluded from the point of production process. The formwork studies and production process of the building component as a façade cladding element are in the focus of this study. Also, the cladding equipments or alternative bounding techniques must be concluded.

As pointed out before, even in most primitive building production process, design, production of components and construction are the basic phases of building facilities. To look for some different and new methods for these phases means to search a new relationship among them.

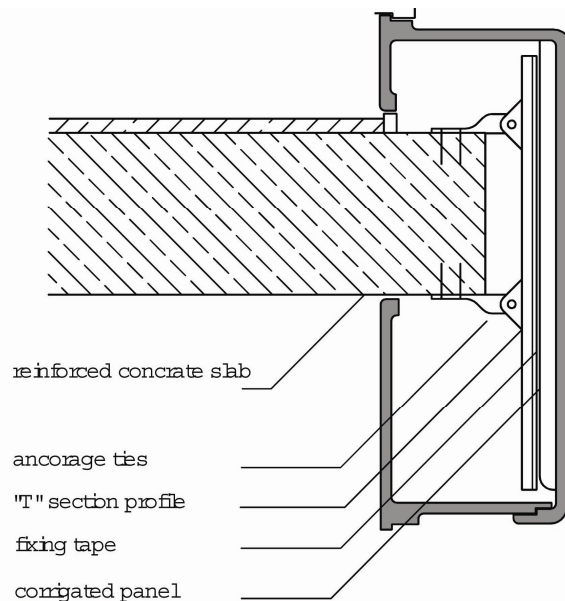

Figure 4.9. Fixing detail

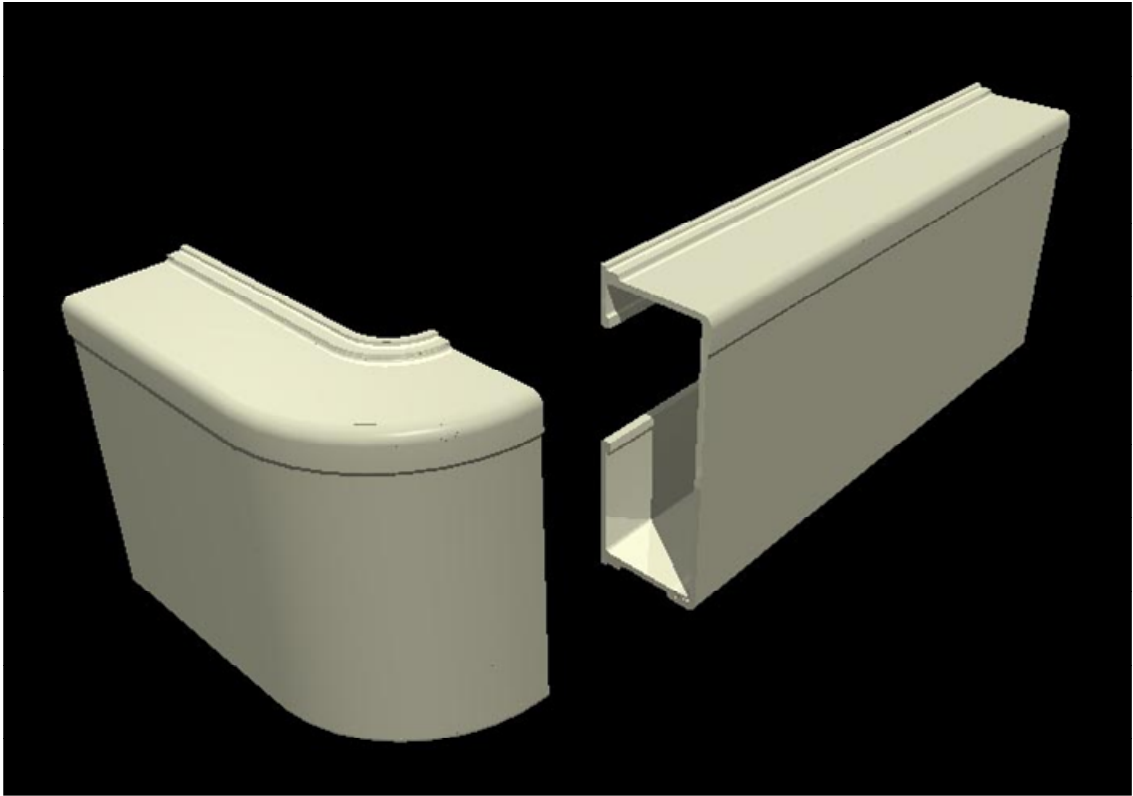

Figure 4.10. Cladding parts

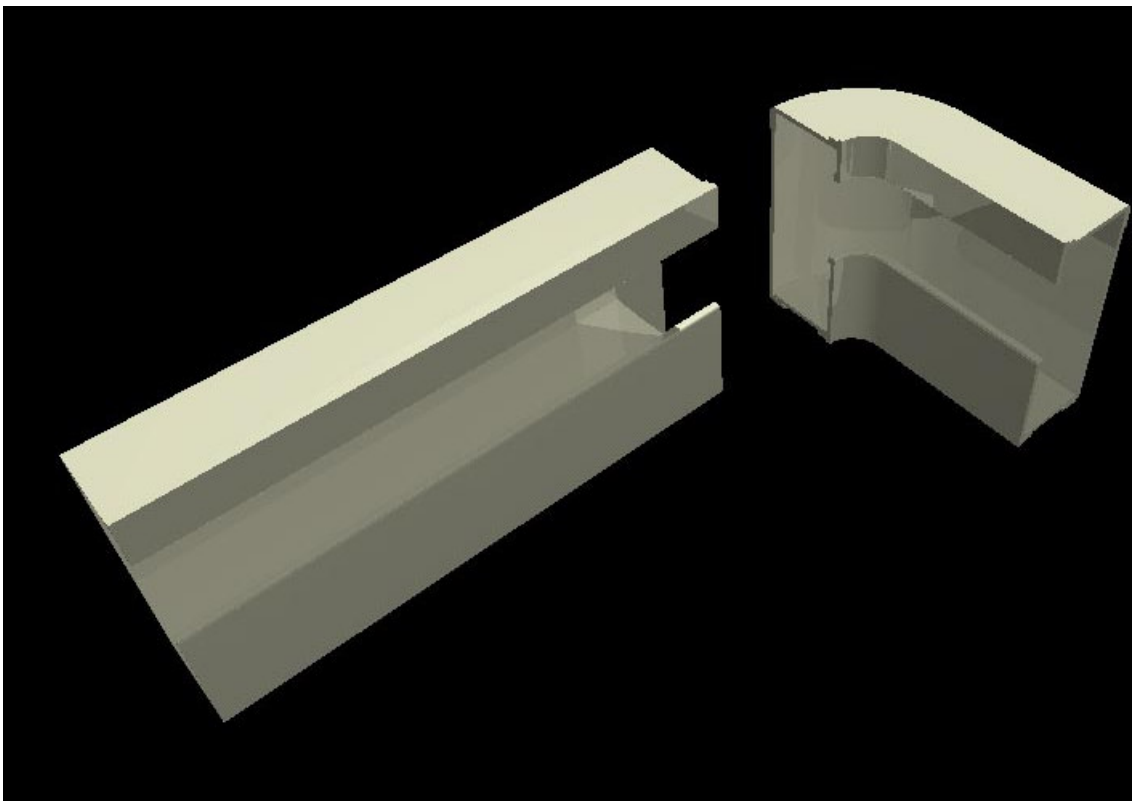

Figure 4.11. Cladding parts, inside view

4.3. Development of Cladding Design

At the beginning of design and development of façade elements, it's necessary to define a set of criteria or arrangement as a guideline:

1. to determine the different and similar parts
2. to determine the dimensions of the façade elements,
3. to determine the formwork type,
4. to determine the raw material,
5. to determine the layers of FCE appropriate to the objectives,
5. to determine the bounding details (FCE to FCE, FCE to building and other components of the building).

Main profile of the parapeth covering as a continuous element and the corner part are the basic elements of design study. The main profile in fact not a stright forward elements. It's necessary to decide whether to use this 100 m radius in FCE design or not to use. It can be accepted that all the façade at this radius is a poligonal shape and has corners as long as perimeter cladding units. Most spreading way to produce continuous profiles is extrusion. Extrusion method needs complicated hardware and formwork. To produce radial elements is a healty way to provide better junctions FCE to FCE. This decision makes the production process clear. Single element production takes longer time than continuous process. But, it's simple and easier than the other method. According the number of repeating parts and pouring duration, formwork needs must be defined. It must be noted that for corner parts left and right versions are needed.

Dimensions of the FCE must be decided according to material stiffness, transportation, handling in montage process and cladding method. Buckling of the parts in free standing position and stocking in production plant and construction site must taken into the considerations.

Formwork type and method selection is the most important part of the design study. The digital data transfer Between CAD and CAM process is obtained by using the CNC machinery.

Layering the FCE is subjected to design according to spesific purposes such as insulation. Outer surface is the most important part of FCE. Protective skin against outside conditions, impact load resistance and the main image of the element resembles in the outer surface.

For the present planar cladding methods many cladding equipments and details are used. Screw and bolt methods gives an opportunity to calibrate the position of the parts. But as state of the art, some newly developed adhesives which used to bound the cladding panels to the supporting system give an opportunity to simplify the montage process.

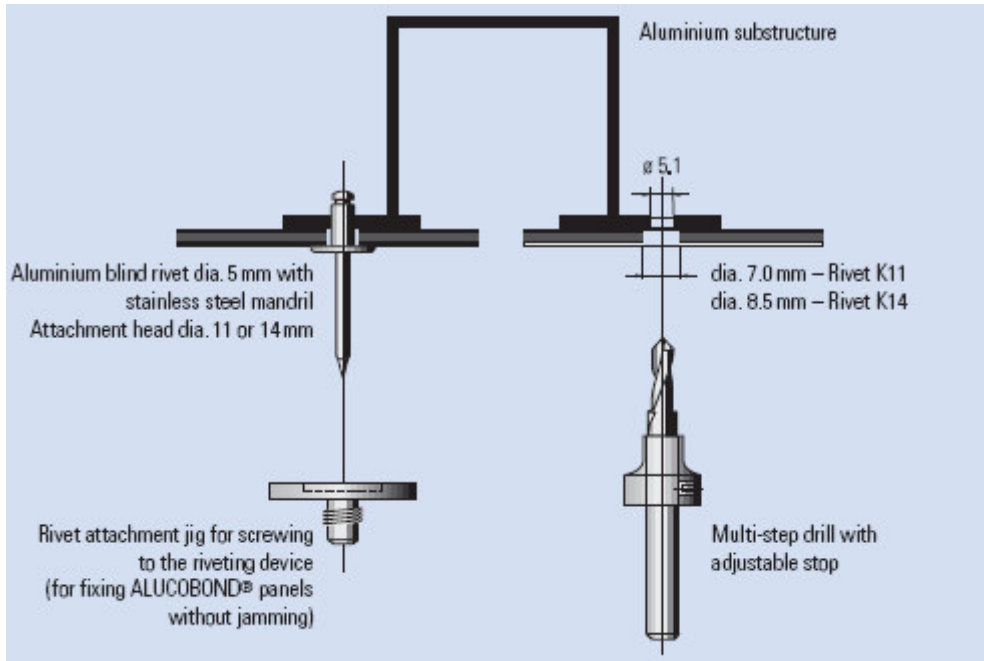

Figure 4.12. Fixing system by screwing

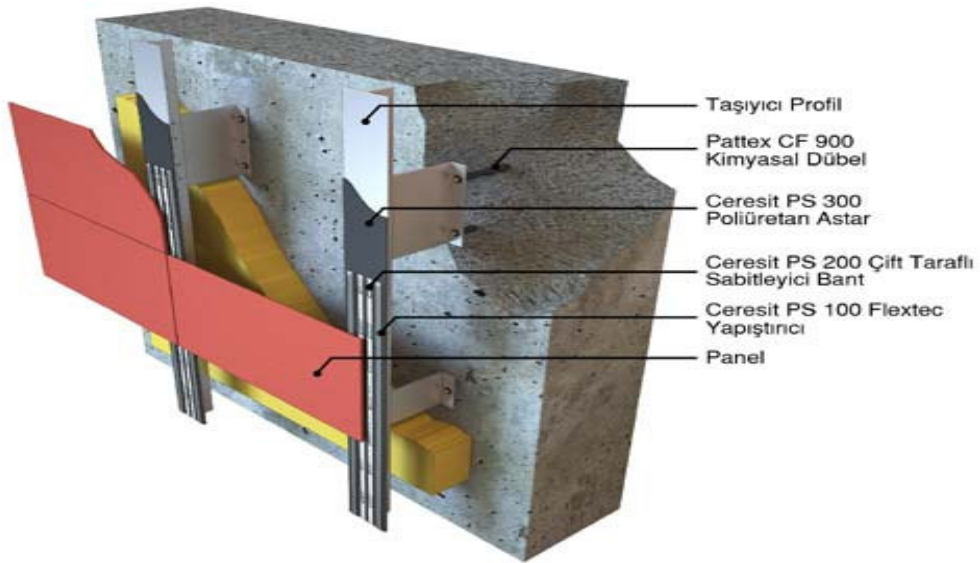

Figure 4.13. Fixing system of the panels by using adhesives
(Source: WEB_8)

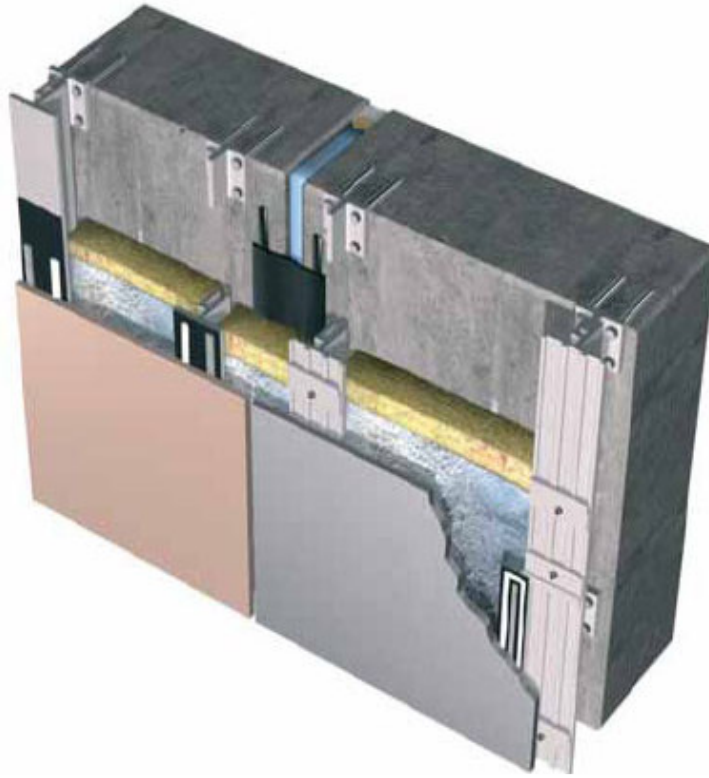

Figure 4.14. Another adhesive system

4.3.1. Material and Production Process Selection

4.3.1.1. Material Selection

Composite materials, as Hull's specified, are strictly related with materials science, metallurgy, polymer technology, fracture mechanics, applied mechanics, anisotropic elasticity theory, process engineering and material engineering (Hull 1995). Composites include natural and sophisticated materials at the same time. According to the matrix material composites in three sections: polymer matrix composites, Metal matrix composites and ceramic matrix composites. Polymer composites are the most spreading compounds for construction. Polymer technology gives useful alternatives for construction sector. Fiber reinforced polymer (FRP) is widely used in construction to build temporary and movable units and some sanitary components such as bath tub.

One of composites' main advantages is how their components - glass fiber and resin matrix - complement each other. While thin glass fibers are quite strong, they are also susceptible to damage. Certain plastics are relatively weak, yet extremely versatile and tough. Combining these two components together, however, results in a material

that is more useful than either is separately. With the right fiber, resin and manufacturing process, designers today can tailor composites to meet final product requirements that could not be met by using other materials. The key factors to consider are fiber, resin and filler, detailed below.

Fiber: Glass-reinforced composites gain their strength from thin glass fibers set within their resin matrix. These strong, stiff fibers carry the load while the resin matrix spreads the load imposed on the composite. A wide variety of properties can be achieved by selecting the proper glass type, filament diameter, sizing chemistry and fiber forms (e.g., roving, fabric, etc.).

Fibers made primarily from silica-based glass containing several metal oxides offer excellent thermal and impact resistance, high tensile strength, good chemical resistance and outstanding insulating properties. Fibers can also be produced from carbon, boron and aramid. While these materials offer higher tensile strength and are stiffer than glass, they cost significantly more. For that reason, carbon, boron and aramid are typically reserved for high-tech applications demanding exceptional fiber properties for which the customer is willing to pay a premium. An alternative is to use a hybrid fiber (combining an expensive fiber with a glass fiber), which improves overall performance yet costs less than using premium fibers alone.

Mats: Available in chopped and continuous-strand, mat is non-woven fabrics that provide equal strength in all directions. Chopped - strand mat contains randomly distributed fibers cut in 3 to 7 cm lengths, held together with a chemical binder. Since the binder dissolves in styrene (a material contained in polyester and vinyl ester resins), chopped-strand mats conform easily to complex shapes. Providing low-cost plastic reinforcement, chopped-strand mat is primarily used in hand lay-up, continuous laminating and some closed molding applications.

Stronger than chopped-strand, continuous-strand mat is formed by swirling continuous strands of fiber onto a moving belt, finished with a chemical binder to hold fibers in place. Its open (non-dense) fiber arrangement accepts a high ratio of resin to fiber, resulting in a thick, smooth, resin-rich finish. Continuous-strand mat is primarily used in compression molding, resin transfer molding, pultrusion, fabricated platforms and stampable thermoplastic applications. These extremely lightweight mats are also used as "surfacing veils."

Woven Fabrics: Woven fabrics are produced on looms in a wide variety of weights, weaves and widths. Bi-directional woven fabrics offer good strength in the 0-

and 90-degree directions, and permit one laminate to be used for faster composite fabrication. They are made from fibers crimped as they pass over and under one another. Under tensile loading, these fibers try to straighten out, causing stress within the resin matrix system, so they are not as strong as fabrics with two separate laminates.

Several different weaves are used for bi-directional fabrics. In a plain weave, each fill yarn or roving alternately crosses over and under each warp fiber. Harness satin and basket weaves, in which the yarn or roving crosses over and under multiple warp fibers at a time, are more pliable and conform easily to curved surfaces. Due to its relatively coarse weave, woven roving wets quickly, is relatively inexpensive and results in a thick fabric used for heavy reinforcement, especially in hand lay-up operations. Exceptionally fine fiberglass fabrics are used for reinforcing printed circuit boards.

Hybrid fabrics are made by combining different types of glass and strand compositions together, such as using high-strength S-type glass strands or small diameter filaments in the longitudinal direction and less costly strands woven across the fabric. Stitching woven and mat fabrics may also create hybrids.

Knitted Fabrics: Knitted fabrics are created by placing yarns atop one another in practically any arrangement and stitching them together. Orienting all strands in one direction, for example, results in a fabric with greater flexibility. Placing the yarns on top of, rather than over and under, each other, makes greater use of their inherent strength. Since they have no crimped fibers, knitted fabrics are more pliable than woven.

Due to the wide variety of yarn orientations and fabric weights, knitted fabrics are tailored to individual customer requirements. They are generally not available in lightweight versions.

Braided Fabrics: Compared to woven, braided fabric has greater strength per weight, but is more expensive because of its complex manufacturing process. Manufacturing costs have decreased, however, making braided fabrics more cost-competitive. Their strength comes from intertwining three or more yarns without any two yarns being twisted around each other, continuously woven on the bias so that at least one axial yarn is not crimped. This arrangement distributes the load efficiently throughout the braid.

Braids come in flat or tubular configurations. Flat braids are used for selective reinforcement, such as strengthening specific areas in pultruded parts. Tubular braid can

be pultruded over a mandrel, producing hollow cross-sections for use in windsurfer masts, lamp and utility poles, and other parts.

Resins: Matrix resins bind glass-reinforcing fibers together, protecting them from impact and the environment. Glass fiber properties such as strength dominate in continuously reinforced composites. When glass is used as a discontinuous reinforcement, resin properties dominate and are enhanced by the glass.

Polymer matrix resins fall into two categories: thermoset and thermoplastic. The difference is in their chemistry. Thermoset resin is chemically comprised of molecular chains that crosslink during the cure reaction (set off by heat, catalyst, or both) and "set" into a final rigid form. Molecular chains in thermoplastic resin are processed at higher temperatures and remain "plastic," or capable of being reheated and reshaped. While the tradeoffs between thermosets and thermoplastics have been debated extensively, engineers will find that material suppliers will tailor matrix resin formulations best for their application.

Fillers: Fillers, such as gypsum, calcium carbonate (limestone), kaolin (clay) and alumina trihydrate are often used in composites to enhance performance and reduce costs. Compared to resin and reinforcements, they are inexpensive. Depending on the material used, fillers can improve smoke and fire resistance, mechanical strength, water resistance, surface smoothness and performance characteristics.

Core: Core Materials are used in sandwich composite construction to add stiffness and strength to a product with minimal increase in weight. A skin of reinforced laminate is applied to both sides of the core material. The skins take the loading while the core is only required to keep the skin a specified distance apart (WEB_1 2007).

In order to design a satisfactory product, it is important to know about the properties of each raw material involved. Basically, the reinforcement material provides mechanical properties such as stiffness, tension and impact strength, while the resin system (matrix) provides physical properties including resistance to fire, weather, and ultraviolet light and corrosive chemicals.

The other factor is cost. An over-designed part costing more to produce cannot compete with products already established in the marketplace. A well-designed part, using the right materials and process to meet the application requirements, is usually commercially competitive, especially when installation and maintenance are factored into the total cost.

Three factors must be considered when choosing reinforcements: fiber (most commonly fiberglass, but also aramid and carbon); form (roving strands, mat and fabrics); and orientation (fiber direction in the part). Fibers can run parallel (uni/longitudinal, 0°), circumferential (bi-axial, 90°) or helical (biased, ±33° to 45°) along the length of the part, and/or with random continuous strands. Strands can also be varied, producing a virtually isotropic laminate with equal strength in all directions. Fiber volume (glass to resin ratio) must also be considered. Resin is heavier than glass; so having higher fiber content will result in a stronger, but lighter weight, part.

Resin (polyester, vinyl ester, and epoxy) and form (wet lay-up or prepreg, a reinforcement saturated with resin) must be carefully chosen to ensure a successful design. Formulators can modify resin with chemicals and fillers to help meet product performance requirements. Resin viscosity, usually expressed in centipoise (cps) units, is important in achieving optimum flow rates for specific manufacturing processes. Laminate design, size and complexity, as well as cost, volume, production speed and market conditions, determine whether the part will be built through Open or Closed Mold processes. To produce a strong and durable laminate by any process, the resin must thoroughly saturate the reinforcements, and the wet laminate must be compacted to remove excess resin and entrapped air (WEB_2 2006).

4.3.1.2. Process Design

Open Mold Processes: Open Mold Processes include spray-up and open contact molding (hand lay-up) in one-sided molds. These low cost processes are commonly used for making boat hulls and decks, RV components, truck cabs and fenders, spas, tubs, showers, and other fiberglass composite products.

In a spray-up application, the mold is waxed, sprayed with gel coat, and then cured in a heated oven at 50 ° C.

After the gel coat cures, the mold is sprayed with a mixture of catalyzed resin (polyester or vinyl ester, 500-1000 cps viscosity) and chopped fiberglass roving (E-glass cut with a chopper gun). Using low-styrene and suppressed-styrene resins, fillers and high-volume/low-pressure spray guns or pressure-fed roller applicators help reduce the emission of volatile organic compounds (VOCs).

The spray-up is rolled out so the laminate can be compacted. Wood, foam or other core material may then be added. A secondary spray-up layer imbeds the core between the laminates (sandwich construction). The part is then cured, cooled and removed from the reusable mold.

Hand Lay-Up: Fiberglass (typically E-glass) continuous strand mat and/or other fabrics such as woven roving is manually placed in the mold. Each ply is sprayed with catalyzed resin (1000-1500 cps). Brushes and rollers are used to work the resin into the fiber, wetting out and compacting the laminate.

Hand lay-up and spray-up methods are often used together to reduce labor. For example, fabric might first be placed in an area exposed to high stress. A spray gun then applies chopped glass, completing the part. Balsa or foam cores may be inserted between the laminate layers in either process. Typical glass fiber volume ranges from 15-35%, with spray-up at the lower end and hand lay-up at the higher end.

Fiber content can be increased up to 50% by curing the part in a vacuum bag at 2-14 psi vacuum pressure and a cure temperature below 177° C. It can be increased up to 70% by using vacuum-assisted resin transfer molding or infusion molding. The applied vacuum compacts the preform while helping the resin penetrate and wet-out the fiber.

Spray-on surface materials, are available to finish parts made through Open or Closed Mold processes. This spray-on surfacing material bonds to fiberglass and other materials. Available in granite-look color blends, solid, accent and custom colors, it provides an attractive finish that is more durable than premium solid surface materials, but as economical as plastic laminate.

4.4. Design

4.4.1. Composite Design

To produce formworks for FCEs is the main focus of this study. But to decide the material composition and production process is a preliminary step to clear the necessities of formwork. As stated above, open mould process is easy to use in production. Knitted fabric fillers give extra strength; and appropriate for hand lay-out method. Sandwich structures have been widely used for applications in the aerospace,

marine and automotive industries where stiffness and strength requirements must be met with minimum weight (Vinson 1999).

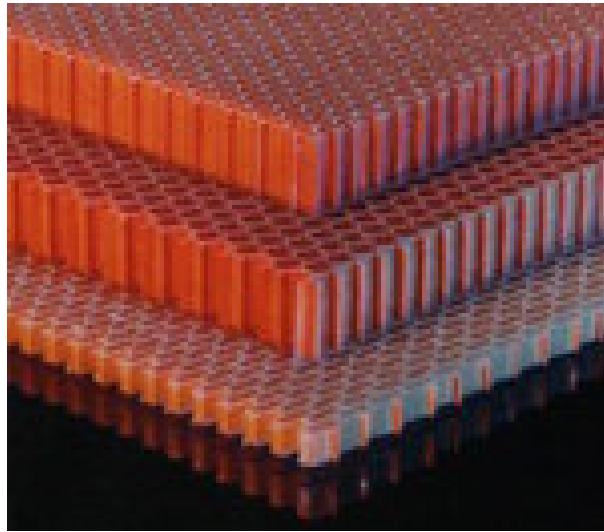

Figure 4.15. honeycomb reinforcement

Vinylester resins are widely used in boat hull constructions and industry such as windmill body construction. Resistance to the outside weather conditions and impact loads; efficient cost make the material appropriate for construction sector.

Fire protection and fire resistance are important criteria for domestic use. Aluminium tri-hydrate is widely used in construction sector to give extra fire resistance to the composites. For example, DuPont, a pioneer firm which used polymer composites in the sector, use this material as main filler in corian countertop products (WEB_2 2007).

Natural granules are appropriate fillers for composites to add extra resistance in low cost. But these materials will add extra weight to the FCE. Coloring additives and surface treatments are possible by using natural fillers also.

Hand lay-up method is suitable layered composite structure. The outer part of the composite must be gel-coat film. Secondary layer will be a mixture of vinylester resin with aluminium tri-hydrate and natural aggregate as main body of composite. The third layer attached to the composite body is honeycomb texture which gives structural resistance to the composite by absorbing resin.

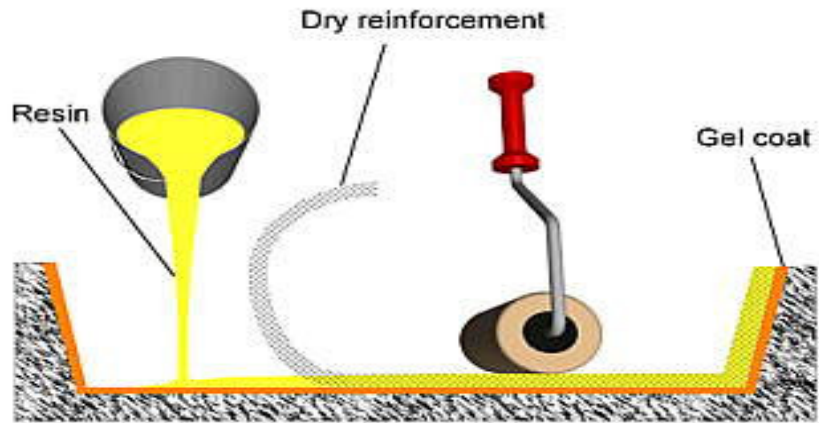

Figure 4.16. Hand lay-up methods

4.4.2. Moulding Design

To use the cnc to produce moulding façade elements must be divided to the parts due to the maximum dimensions of the cnc machines. In subtractive method, wooden or plastic blocks will be processed. Maximum dimensions of the block depends on specifications of the machine. In fact the CAD data will be subjected to transform a CAM interface data to operate the cnc. To prepare the master model an appropriate medium will be used. Later, moulding polymers will be used to held the formwork. Multiplying the formwork can be done by using the master copy.



Figure 4.17. Cnc machine

Assembly of the processed parts will be done by hand. This instance needs a qualified workmanship. Boat hull construction process is a good example for this process. Sanding and leveling will be the final touch to the formwork. To produce the FCEs hand lay-up method will be used.



Figure 4.18. An open mould example
(Source: WEB_9)

CHAPTER 5

CONCLUSION

Changing relations in design and construction in architecture must be taken into the consideration with changes in technology. Triology of building facility, design, production and construction is still valid. Es said before, beginning from the first brick making activity production process has been a part of design and construction. Prefabricated construction is the ultimate point of production and montage process. But, CAM tools in architecture open a new era in design. Three dimensional modelling, virtual reality and similar apparatus, beyond the cartesian geometry, offers a new movement field to designers. Conventional methods which used data transfer between design and construction are subjected to change. Digital data transfer for complicated modeling facilities in production process is still used in different sectors.

As similar to the 19th century examples, technology transfer from the engineering disciplines seems still in use for construction sector. To develop or quote appropriate technology was the main task of this study. As seen at the case study, necessary technology for digital transferring the design data to production is available and still in use.

Designers are subjected to the over information by producers of building components in daily life. Construction industry depends on scientific researches to develop new alternative materials. Natural construction materials and conventional artisanal workmanship are still valid as a sign of high class ownership in building. But some pioneering examples in architecture depend on new materials and techniques to realize the complex 3D modeling designs.

To search for appropriate technologies must be depends on digital data transfer

REFERENCES

- Akgun, Y (2004). “*Perception of Space Through Representation Media*”, UPMT, İYTE, Fen Bilimleri Enstitüsü
- Allen, E (2004). “*Fundamentals of Building Construction*”, John Wiley and Sons, New Jersey
- Allen, W (1997)., “*Envelope Design for Buildings*”, Architectural Press, Oxford
- Broadbent, G (1995). “Architectural Education”, in *Educating Architect* (ed) Academy Editions, London
- Brock, L (2005). “*Designing the Exterior Wall : An Architectural Guide to the Vertical Envelope*”, Hoboken, John Wiley, N.J.
- Burkhardt, J (1944). “*The Civilisation of the Renaissance in Italy*”, Phadon Press, London
- Buswell, (2007). “Freeform Construction: Mega-scale Rapid Manufacturing for Construction”, *Automation in Construction* Volume 16, Issue 2
- Chua, K. and Fai, L (1997). “*Principles and Applications in Manufacturing*”. New York Willy Publications
- Daniels, D (1998). “Improving Glass Performans”, *Architectural Record*, August, 131
- Erdoğan, O. 1999). “*Performance criters and curtain wall systems of building*”.. Yüksek Lisans Tezi, Trakya Üniversitesi, Fen Bilimleri Enstitüsü, ,
- Erer, H (2000). “CNC Tezgahlar”, *Mühendis ve Makina*, Dergisi, s.486, p. 37-40
- Frampton, K (1985). “*Modern Architecture: a Critical History*”, Thames and Hudson London
- Frampton, K (1991). “Reflections on the Autonomy of Architecture: A Critic of Contemporary Production: In out of Site”, in Ghirardo, D.[Ed], *Architecture as Science*, Bay Press, Seattle
- Galle, P (1999). “Design as Intentional Action: a Conceptual Analysis”, *Design Studies*, no. 20, pp: 63-4
- Giovannini, J (2000). “Building a Better Blob”, *Architecture*, vol.89, no.9
- Guthrie, P. Coventry, S. Woolveridge, C (1999). “*The Reclaimed and Recycled Construction Materials Handbook*”, London, CIRIA
- Gür, N. A (2001). “*Model for the Analysis and Evaluating of Llight Curtain Walls*”, Yüksek Lisans Tezi, İstanbul Teknik Üniversitesi, Fen Bilimleri Enstitüsü

- Harris, C.M (1993). *“Dictionary of Architecture and Construction”*, McGraw Hill Inc., New York.
- Hull, D (1995). *“An Introduction to Composite Materials”*. Cambridge University Press
- Iano, J (2004). *“Fundamentals of Building Construction”*, John Willey and Sons, New Jersey
- Kolarevic, B (2000). *“Architecture in the Digital Age: Manufacturing”*, Taylor and Francis Group, New York
- Kolarevic, B (2003). *“Digital Age: Manufacturing”*, Taylor and Francis Group, New York
- Kostof, S (1977). *“The Architects in the Middle Ages East and West”*, MIT Press, Cambridge
- Kostof, S (1992). *“The Architect: Chapters in the History of the Profession”* (New York:Oxford University Press)
- Lecuyer, Annette, (1997). “Building Bilbao”, *Architectural Review*, vol. 102, No1210
- Lewis, M (1995). *“Modern Stone Cladding”*, ASTM Pub., Philadelphia
- Lynn, G (1999). *“Animate Form”*, Princeton Architectural Press, NY
- Mc Donald, W (1977). “Roman Architects”, *The Architect*, ed. Kostof, S. Oxford University Press
- Mitchell, W (1995). *“City of Bits: Space, Place, and the Infobahn”*, Cambridge, Mass.: MIT Press
- Mitchell, W (2000). “Information Technology”, in Knox, P. *et all.*[Eds] *Design Professions and the Built Environment*, John Willy and Sons Ltd., Sussex
- Musaagaoglu, Bilge (2005). *“Performance of the Stone Building Envelope: Cladding to Curtain Wall”*, UPMT, Middle East Technical University, Fen Bilimleri Enstitüsü
- Ochshorn, J (2003). *“Encyclopedia of Twentieth Century Architecture, Curtain-wall Systems in 20th-Century Architecture”*, Taylor and Francis Publishers, New York
- Oesterle; et al (2003)., *“Double Skin Facades”*, Prestel, London
- Perez-Gomez, A. Pelleterier, P (1997). *“Architectural Representation and Perspective Hing”* MIT Press, Cambridge

- Quirouette, R (1982). “*Building Envelope Design Using Metal and Glass Curtain Wall Systems*”, Publication of Division of Building Research, National Research Council, Ottawa
- Robbins, E (1994). “*Why Architects Draw?*” MIT Press, Cambridge
- Row, G (1992). “*Design Thinking*”, MIT Press, Cambridge
- Schaupp, W (1967). “*External Walls- Cladding, Thermal Insulation*”, Damp, Prestel, London
- Trachtenberg, V. Hyman A (1986). “*Architecture from Pre-History to Postmodernism*”, Harry Abram Pub. NY
- Uçar, A (2006). “*Bilgisayar Ortamında Mimarlığın Mimarlık Eğitime Etkileri*”, UPMT, YTU Fen Bilimleri Enstitüsü
- Verstijnen, I (1998). “Sketching and Creative Discovery”, *Design Studies*, vol:19 no.4
- Vinson, J. R (1999). “The Behavior of Sandwich Structures of Isotropic and Composite Materials”. *Technomic*, vol.234, p.23-9
- Vyzantiadou, A (2003)., “Point Fixed Glazing Systems: Technological and Morphological Aspects”, *Journal of Constructional Steel Research*, vol.60, issue 8
- WEB_1, 2007. Compositesone’s Web Site. 11/02/2007. <http://www.compositesone.com>
- WEB_2, 2006. American Composites Manufacturers Association’s Web Site. 1/10/2006. <http://www.acmanet.org>
- WEB_3, 2007. Future Systems Web site. 1/10/2006. [http:// www.future-systems.com](http://www.future-systems.com)
- WEB_4, Scheffler, M. J (2006)., “Thin Stone Wall Systems”
www.wbdg.org/design/env_wall_thin_stone.php
- WEB_6, Columbia University web site, 1/10/2006. <http://www.arch.columbia.edu>
- WEB_7, Foster and Partners web site, 5/02/2007
[http:// www.fosterandpartners.com/Projects](http://www.fosterandpartners.com/Projects)
- WEB_8, Henkel web site, 5/02/2007, <http://www.henkel-ua.com>
- WEB_9 Poliya web site, 2/03/2007, <http://www.poliya.com.tr>
- Wiggenton, (1996). “*Glass in Architecture*”, LondonPhaidon Press,
- Wiley, D., (2005). “Architectural Education in the Digital Environment”, in Harder, E.[Ed] *Writings in Architectural Education*. Form and Co Prints, Copenhagen

Yarkan, G.K, (2001). “*Bilgisayar Ortamında Mimarlığın Mimarlık Eğitime Etkileri*”, UPMT, YTU Fen Bilimleri Enstitüsü

Zahner, (1999). “*Selection Specifications*”, Allen Pub. New York

Zellner, P., (1999). “*Hybrid Space: New Forms in Digital Architecture*”, Thames and Hudson, London