

ANALYSIS AND RE-DESIGN OF AN OUTDOOR FITNESS EQUIPMENT'S MECHANISM

**A Thesis Submitted to
the Graduate School of Engineering and Sciences of
İzmir Institute of Technology
in Partial Fulfillment of the Requirements for the Degree of**

MASTER OF SCIENCE

in Industrial Design

**by
Nazife Ash KAYA**

**August 2011
İZMİR**

We approve the thesis of **Nazife Aslı Kaya**

Prof. Dr. Önder Erkarıslan
Supervisor

Assist. Prof. Dr. Koray Korkmaz
Co-Supervisor

Assoc. Prof. Dr. Bülent Yardımođlu
Committee Member

Assist. Prof. Dr. Yenal Akgün
Committee Member

24 Agust 2011

Prof. Dr. Önder Erkarıslan
Head of the Department of Architecture

Prof. Dr. Sedat AKKURT
Dean of the Graduate School of
Engineering and Sciences

ACKNOWLEDGEMENTS

It is with great pleasure that I thank my advisor, Prof. Dr. Önder Erkarıslan for his help, support, and guidance throughout my research and studies.

I would like to thank to my co-adviser, Assist. Prof. Dr. Koray Korkmaz, whom I had the pleasure to work on mechanisms which I present in this thesis.

Thanks to Assoc. Prof. Dr. Bülent Yardımođlu and Assist. Prof. Dr. Yenal Akgün for their encouraging words and for agreeing to be part of the committee.

Finally, I want to thank my family for their endless love and support.

ABSTRACT

ANALYSIS AND RE-DESIGN OF AN OUTDOOR FITNESS EQUIPMENT'S MECHANISM

This research study emphasizes the importance of biomechanics and mechanics knowledge in industrial design as an interdisciplinary approach for designing safety products through an example, FE02 Stepper.

First of all, the concurrency of FE02 Stepper with human movements was analysed. After the errors were determined, a new mechanism was designed and analysed by using algebraic position analysis method and implemented in Microsoft Excel 2007[®] and modeled by using Rhinoceros Evolution v4.0[®].

ÖZET

BİR DIŐ MEKAN FİTNESS ALETİNİN MEKANİZMA ANALİZİ VE YENİDEN TASARIMI

Bu alıŐma, FE02 Stepper isimli bir dıŐ mekan fitness aleti zerinden, gvenli rnler tasarlamayabilmek iin, endstri rnleri tasarımında biyomekanik ve mekanizma bilgisinin nemini, interdisipliner bir yaklaŐımla ortaya koymaktadır.

ncelikle, FE02 Stepper'ın insane hareketleriyle uyumu incelenmiŐ, uyumsuzluklara neden olan hatalar tespit edildikten sonra yeni bir mekanizma tasarlanmıŐtır. Tasarlanan bu yeni mekanizma, algebraic pozisyon analizi yntemi kullanılarak analiz edilmiŐ ve Microsoft Excel 2007[®] programıyla detaylı incelenmiŐtir. En son olarak mekanizma ve rn Rhinoceros Evolution v4.0[®] programı kullanılarak grselleŐtirilmiŐtir.

TABLE OF CONTENTS

LIST OF FIGURES	viii
LIST OF TABLES.....	X
CHAPTER 1. INTRODUCTION	1
1.1. Aim of the Study	Error! Bookmark not defined.
1.2. Methods of the study.....	2
CHAPTER 2. BIOMECHANICS OF HUMAN STEP-UP MOTION.....	4
2.1. Planes and Axes of Motion of the Hip.....	6
2.2. Planes and Axes of Motion of the Knee	8
2.3. Planes and Axes of Motion of the Ankle	10
2.4. Motion Angles of Lower Extremity	12
2.5. Angle of Gait.....	13
CHAPTER 3. STRAIGHT LINE MECHANISMS.....	16
3.1. Watt’s Straight Line Mechanism	17
3.2. Evans’ Straight Line Mechanism.....	18
3.3. Robert’s Straight Line Mechanism	19
3.4. Chebyshev’s Straight Line Mechanism	20
3.5. Peaucellier’s – Lipkin’s Straight Line Mechanism.....	21
3.6. Hoeken’s Straight Line Mechanism.....	22
3.7. Designing Multi-loop Linkages	23
CHAPTER 4. A PROPOSAL FOR DERIVED MECHANISM FROM HOEKEN'S STRAIGHT LINE LINKAGE	25
4.1. Problems of FE02 Stepper’s Mechanism.....	25
4.2. Design of FE02 Stepper’s New Mechanism.....	31
4.3. Position Analysis of FE02 Stepper’s New Mechanism	34
4.3.1. Algebraic Position Analysis.....	34

CHAPTER 5. CONCLUSIONS	40
REFERENCES	42

LIST OF FIGURES

<u>Figure</u>	<u>Page</u>
Figure 1. Planes.....	4
Figure 2. Lower Leg Flexion and Rotation.....	5
Figure 3. Ankle Extension and Abduction.....	5
Figure 4. Posterior Hip Muscles	7
Figure 5. Anterior Hip Muscles	7
Figure 6. Knee Anatomy.....	9
Figure 7. Knee Axes	9
Figure 8. Foot Muscles	11
Figure 9. Motion Angles	Error! Bookmark not defined.
Figure 10. Footprints	13
Figure 11. Measuring the Distance of Footprints and Borderline	14
Figure 12. Posture's Plane During Walking	Error! Bookmark not defined.
Figure 13. Axis Deviations	Error! Bookmark not defined.
Figure 14. Watt's Approximate Straight Line Linkage.	18
Figure 15. Evans' Straight Line Mechanism	18
Figure 16. Robert's Straight Line Mechanism	19
Figure 17. Chebyshev's Straight Line Mechanism	20
Figure 18. Peaucellier's Straight Line Mechanism	21
Figure 19. Hoeken's Straight Line Linkage.....	22
Figure 20. Single-loop Linkage	23
Figure 21. A Multi-loop Linkage.....	25
Figure 22. FE02 Stepper	25
Figure 23. FE02 Stepper and Exercise.....	26
Figure 24. FE02 Stepper's Mechanism.....	26
Figure 25. FE02 Stepper Technical Drawing (mm)	27
Figure 26. Leg's Appearance During Exercise.....	29
Figure 27. Angles During Exercise.....	30
Figure 28. Ankle Over-strain	30
Figure 29. Merging Two Hoeken's Straight Line Linkage	32

Figure 30. Hoeken Linkage	31
Figure 31. Measurement of Angles in the Four-bar Linkage	34
Figure 32. Graph of New Mechanism's Geometrical Trajectory	38
Figure 33. Re-design of FE02 Stepper.....	39

LIST OF TABLES

<u>Table</u>	<u>Page</u>
Table 1. Kinematic Pairs.....	16
Table 2. Link Ratios for Smallest Attainable Errors in Straightness.....	33
Table 3. Link 2.....	36
Table 4. Link 3.....	36
Table 5. Link 4.....	37
Table 6. Link 5.....	37
Table 7. Link 6.....	37

CHAPTER 1

INTRODUCTION

Biomechanics has been defined as the study of the movement of living things using the science of *mechanics* (Hatze, 1974) and provides key information on the most effective and safest movement patterns, equipment, and relevant exercises to human movement. Biomechanics is not only an important science for solving human movement problems (Knudson, 2003) but also is important to set choreography of the product's movement for synchronizing with human motions for prevents overload tissues and injuries. Donald A. Norman, writer of *The Design of Everyday Things* (2002) states that injuries aren't users' fault; it's the fault of the design. Thereof, the safety of products is one of the main responses of designers, for fulfilling the safety, designing the choreography of the product's movement is a designers' response too. Design of a safe task and safe equipment, based on the concept of 'fitting task to the person', requires that there be a match between the requirements of the tasks and the physical and mental capabilities of the people performing those (Imrhan, Sarder, & Mandahawi, 2009). Outdoor fitness equipments are kind of machines with respect to statement of Reuleaux's (1963) definition: a machine is a collection of mechanisms arranged to transmit forces and do work. And also outdoor fitness equipments are good examples for human-machine interactions as industrial products in the context of 'fitting task to the person'. In addition to that, these machines are good sources for observing and analyzing those interactions because the essential objective in the development of outdoor fitness equipments' is train the body. Although the performance-related aspects are of prime importance, another major requirement to the outdoor fitness equipments is injury prevention, in addition to that, an optimal match between the users' requirements and the equipment characteristics is essential (Dabnicki, 1998).

Not only outdoor fitness equipments but also most of products have a kind of movement that provides to achieve to desire task (take for example dishwashers, vacuum cleaners, umbrellas, toasters and so on) and the movement could be obtained by mechanisms. In order to match users' motion characteristics with products movement

and for effectively achieving and fulfilling the function goal, mechanisms should be known as well as biomechanics in the context of *industrial design*.

1.1. Aim of the Study

This research study emphasizes importance of biomechanics and mechanics knowledge in industrial design as an interdisciplinary approach for designing safety products through an example.

1.2. Methods of the Study

This study is constructed according to provide an understanding the relationship between industrial design, biomechanics and mechanics. The main structure of this study debate on, examining the outdoor fitness equipment's mechanism and after analyzing the mechanism's concurrency with human movement, for enhancement, designing an appropriate mechanism.

In the first phase of the study, biomechanics were perused for understanding the human motion's principles. After the output motion of training with the outdoor fitness equipment was observed and analyzed, the motion's compatibility with natural human movement was discussed. As the result of discussion, the problems were determined.

In the second phase, mechanisms were perused and basic principles of kinematic were learned. The types of straight line mechanisms classified. In addition to these, In the third phase, current in use outdoor fitness equipment's mechanism was examined and after identifying the reason of incompatibility, a mechanism was chosen for modify. The chosen mechanism was modified and its simple physical models were constructed in addition to its CAD models and computer simulations that were created by Rhinoceros Evolution and Microsoft Excel softwares.

This study includes the following structure:

Chapter 1 *Introduction* aims to build an introductory background to the research subject.

Chapter 2 *Biomechanics of Human Step-up Motion* presents the principles of biomechanics of step-up motion by inspection of knee, hip and ankle anatomy.

Chapter 3 *Straight Line Mechanics* presents the major mechanisms which generate straight line trajectory and the principles of designing multi-loop linkages

Chapter 4 *A Proposal for Derived Mechanism from Hoeken's Straight Line Linkage* includes the chosen mechanism's modification, analysing and modelling process.
Chapter 5 *Conclusion* presents the results and remarks.

CHAPTER 2

BIOMECHANICS OF HUMAN STEP-UP MOTION

Movement in the body takes place at the joints and can occur in any plane. Sagittal plane is the vertical plane that passes through the spinal cord dividing the body into left and right regions. In general, motion in a sagittal plane is known as flexion if it moves the distal segment anteriorly or folds it and extension if the segment moves posteriorly or straightens. Abduction is used for movement away from the sagittal plane while adduction is movement toward it. Rotation is used for a twisting action about the long axis of a limb.

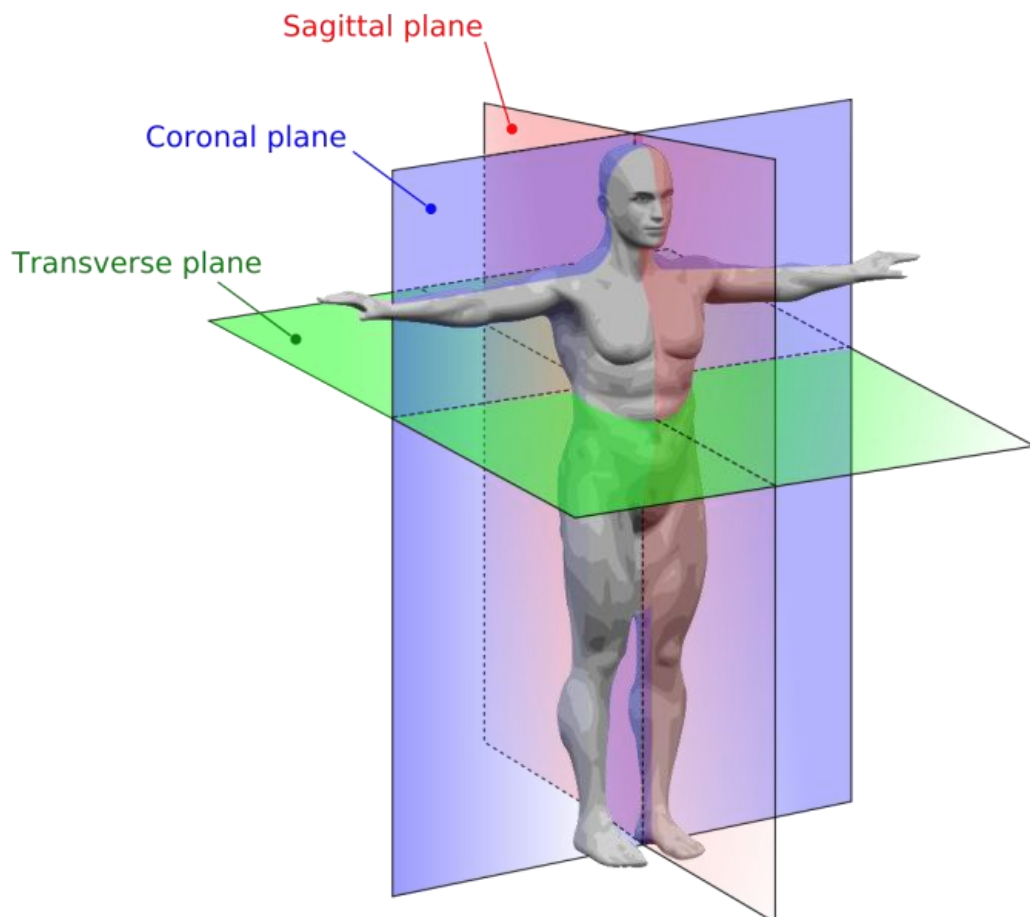

Figure 1. Planes
(Source: Wikipedia *a*, Human Anatomy Planes, 2011)

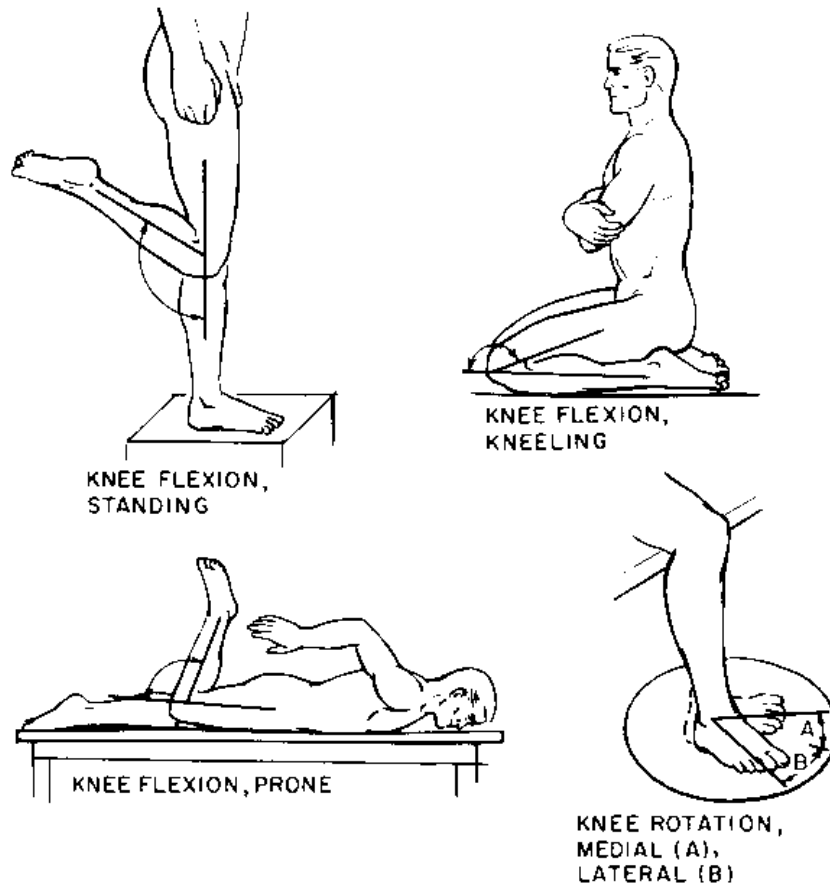

Figure 2. Lower leg flexion and rotation
(Source: Overt *a*, Anatomy of Knee, 2011)

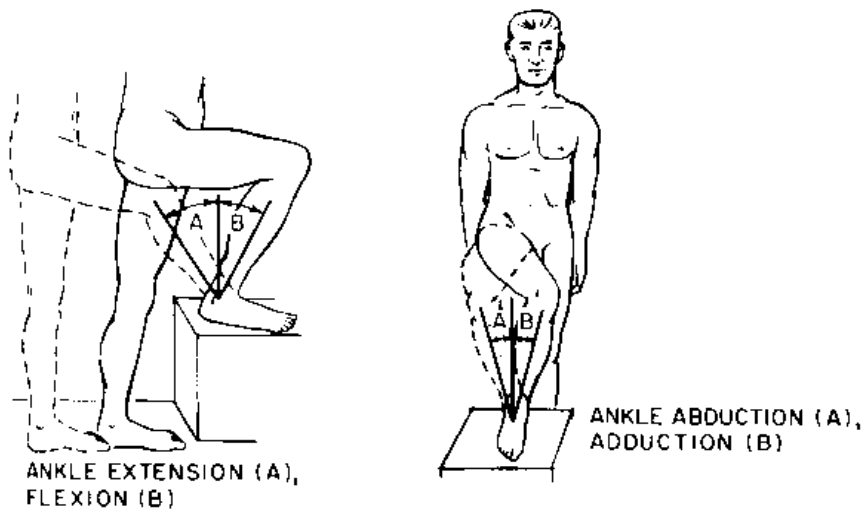

Figure 3. Ankle Extension and Abduction
(Source: Overt *b*, Anatomy of Knee, 2011)

Step-up motion is a part of gait; indeed, it is stance phase of gait (Oatis, 1988). Gait is also called as walking and human locomotion. In this thesis, whole gait motion wasn't investigate, but for understanding the plane of normal step-up motion, flexions, extensions, abductions and adductions of ankle, knee and hip at stepping up and angle of gait was analyzed.

There are lots of researches on gait. In addition to these, knee, foot, ankle, hip, low extremity, stair climbing and running researches could be find. But there are few researches on 'step-up' motion and most of them are specialized on elders and knee arthroplasty / prosthesis predominance.

Compared with younger adults, older adults have greater difficulty maintaining and recovering postural stability, particularly in the sagittal plane (Maki et al., 1994; McIlroy & Maki, 1999). One likely cause of this difficulty is weakness of the hip abductor muscles and other muscles that control frontal-plane or "lateral" stability (Maki et al., 2000; Rogers & Mille, 2003). Step-up exercises have been suggested for strengthening the hip abductor muscles and improving balance in older adults (Sherrington et al., 2004; Steadman et al., 2003). Because of this, outdoor fitness equipment (FE02 stepper) would be very helpful for health if its motion output was correct.

For understanding the failures of motion which FE02 stepper causes at the user's body, occurrences of normal movement's planes should be investigate.

It would be facilitate considering each of the segments of lower extremity as a separate entity.

2.3. Planes and Axes of Motion of the Hip

The hip joint is a classic ball-and-socket joint allowing flexion, extension, adduction, abduction, and medial and lateral rotation and motions can occur at all axes. Hip rotation occurs when the femur moves along its longitudinal axis.

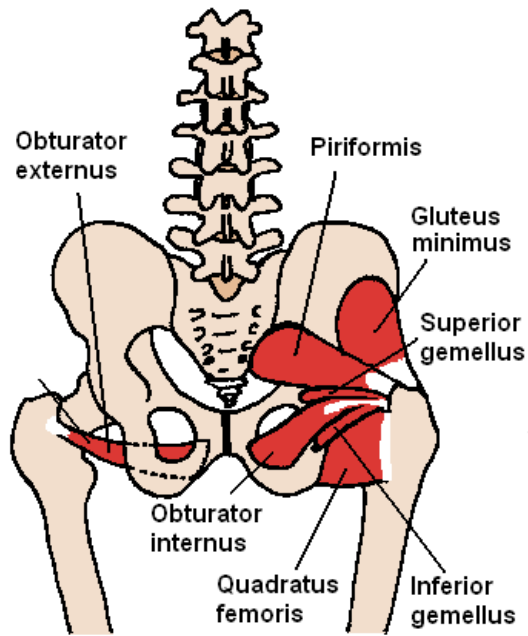

Figure 4. Posterior hip muscles
 (Source: Wikipedia, Hip Anatomy, 2011)

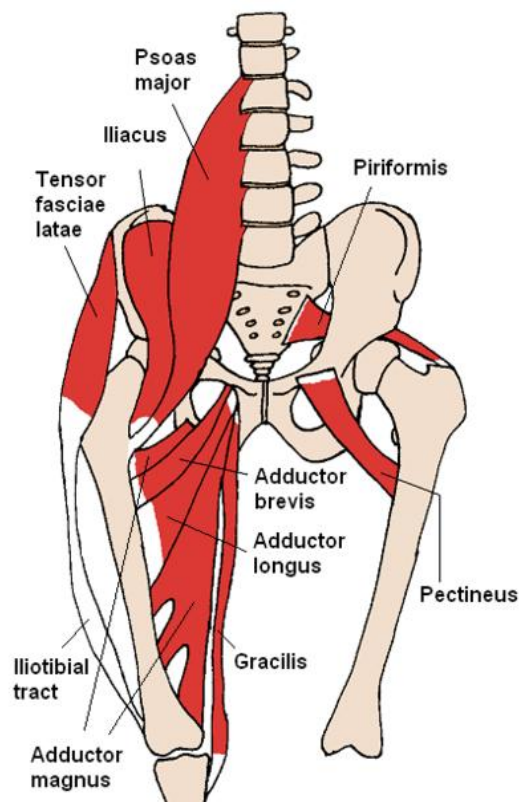

Figure 5. Anterior hip muscles
 (Source: Wikipedia, Hip Anatomy, 2011)

Hip muscles can be grouped; anterior muscles are flexors, posterior muscles are extensors, medial muscles are adductors and buttock muscles are abductors. The iliofemoral, ischiofemoral and pubofemoral ligaments limit hip extension. The pubofemoral ligament limits abduction. Other movements of the hip (flexion and adduction) are limited by muscle stretch (Philippon et al., 2007).

If the hip is forced to move over these limitations, tears and hypertrophy can occur.

2.2. Planes and Axes of Motion of the Knee

The knee joint is a classic hinge joint allowing only flexion and extension, with other words, knee moves at only sagittal plane. The bones of the knee, the femur and the tibia, meet to form a hinge joint. The joint is protected in front by the patella (kneecap). The knee joint is cushioned by articular cartilage that covers the ends of the tibia and femur, as well as the underside of the patella. The lateral meniscus and medial meniscus are pads of cartilage that further cushion the joint, acting as shock absorbers between the bones. Ligaments help to stabilize the knee. The collateral ligaments run along the sides of the knee and limit sideways motion. The anterior cruciate ligament (ACL), connects the tibia to the femur at the center of the knee. Its function is to limit rotation and forward motion of the tibia. The posterior cruciate ligament, or PCL (located just behind the ACL) limits backward motion of the tibia (Blackburn & Craig, 1980).

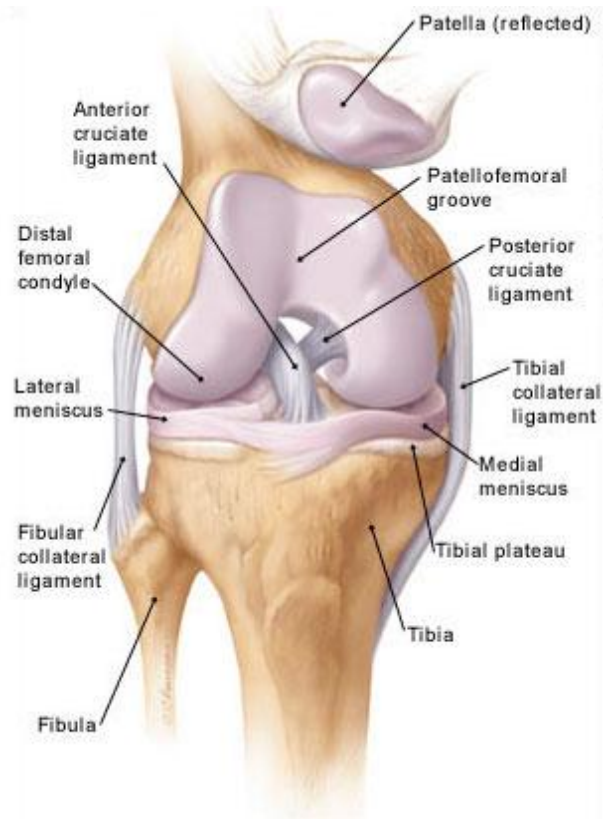

Figure 6. Knee Anatomy
 (Source: Aclsolutions, Knee Anatomy, 2011)

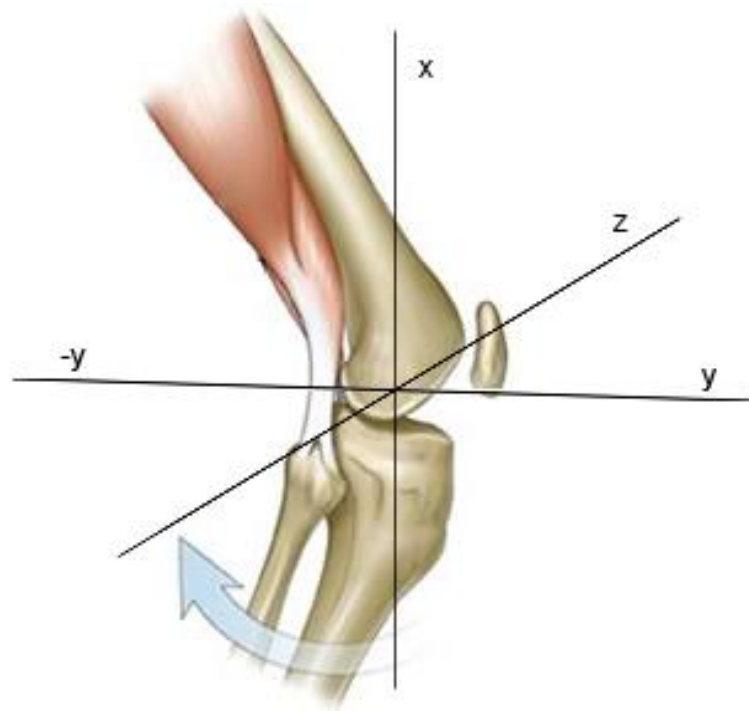

Figure 7. Knee Axes
 (Source: Aclsolutions, Knee Anatomy, 2011)

Because of knee anatomy and its joint type, motion can be occur only at sagittal plane safely, if the sagittal plane is accepted as y axis according to coordinate system, knee can make flexion and extension only through $(-y)$ axis.

If the tibia is forced to move through z axis, lateral and collateral ligaments and also tibial and fibular collateral ligaments can tear; if the tibia is forced to move through $(+)y$ axis the anterior cruciate ligament and posterior cruciate ligament can tear (Marshall & Rubin, 1977).

2.3. Planes and Axes of Motion of the Ankle

The ankle joint is formed where the foot and the leg meet. The ankle, or talocrural joint, consists of a bony fit between the talus and the tibia proximally and medially (internally) and the talus and the fibula laterally (externally) (Riegger, 1988).

Foot and ankle motion in the sagittal plane (flexion - extension) occurs about a medial-lateral axis, motion in the coronal plane (abduction-adduction) occurs about an anterior - posterior axis, and motion in the transverse plane (medial lateral [internal-external] rotation) occurs about a longitudinal axis (Oatis, 1988). Because the axes of motion for the ankle, subtalar, and midtarsal joints are oblique in three planes, each of these joints will have some component of motion in each plane, that is, dorsiflexion-plantar flexion (sagittal plane), inversion-eversion (frontal plane), and abduction-adduction (horizontal plane). With reference to the main ankle motions, however, anterior compartment muscles cross the ankle anteriorly and act as dorsiflexors, whereas the muscles of the lateral and posterior compartments cross the ankle posteriorly and become plantar flexors. Because no muscles attach to the talus, none of these muscles act exclusively on the ankle.

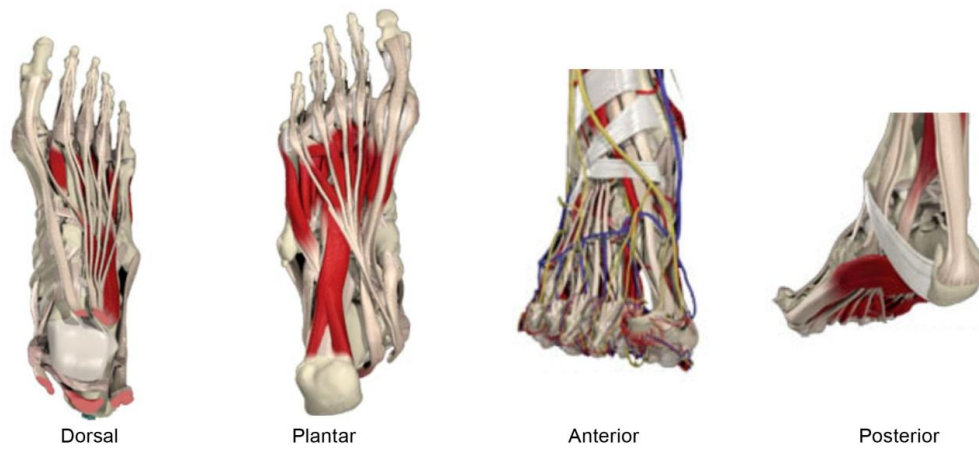

Figure 8. Foot muscles
(Source: Northcoastfootcare, Foot Anatomy, 2011)

During walking, the centre of body mass must pass from behind the weight bearing foot to in front of it. For this to take place, the foot must function as a sagittal plane pivot (Dananberg, 2000).

2.4. Motion Angles of Lower Extremity

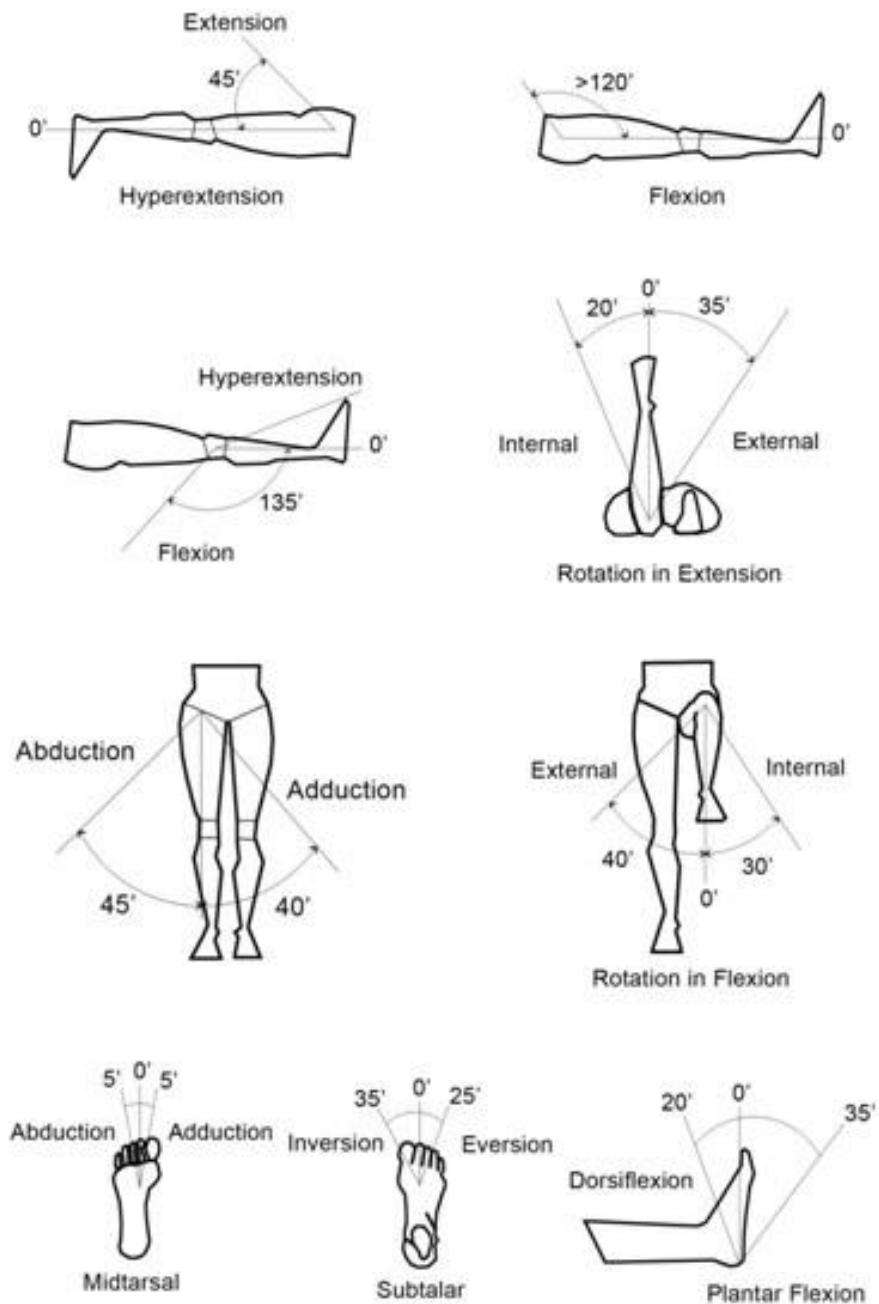

Figure 9. Motion angles
(Source: Panero & Zelnik, 1979)

Limitation of hip extension angle is 45° , flexion is over 120° , abduction is 45° and adduction is 40° .

Limitation of knee flexion angle is 135° ; during extension position (these rotations can occur by rotation of femur) internal rotation angle is 20° , external rotation

angle is 35°, during flexion position (these rotations can occur by rotation of tibia and fibula) internal rotation angle is 30°, external rotation is 40°.

Limitation of midtarsal joint abduction and adduction angles are 5°, subtalar joint inversion angle is 35°, eversion angle is 25°. Foot dorsiflexion angle is 20°, plantar flexion is 35°.

If angle of motions over these limitations, injuries will be occur.

2.5. Angle of Gait

The term angle of gait (AOG) refers to the mid-sagittal position of each foot in midstance relative to the direction of forward movement during gait (Wilkinson et al., 1995). The parameters of angle of gait, with the former described by Sgarlato (1965), as the deviation of the sagittal plane of the foot to the line of progression of both feet (Donatelli, 1996) and the latter being defined as the distance between both feet (Sgarlato, 1965). The angle of gait is also referred to as the 'foot placement angle' and known also mechanical axis of gait (Kernozek & Ricard, 1990).

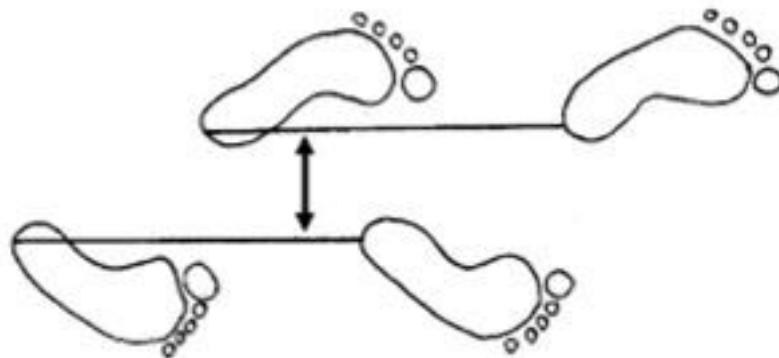

Figure 10. Footprints
(Source: Curran et al., 2005)

There is few researches on angle of gait which are using footprint impressions, although the method is very simple and inexpensive. The method consists on measuring the distance of footprints and borderline.

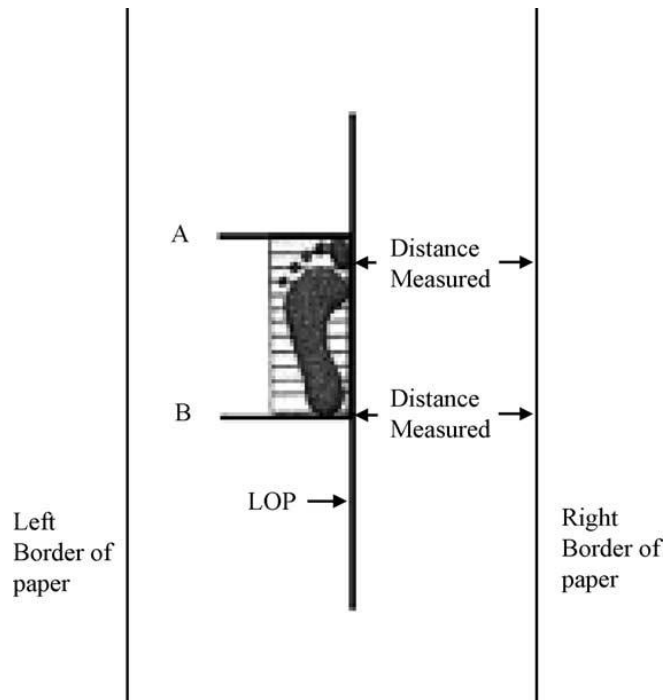

Figure 11. Measuring the distance of footprints and borderline
(Source: Taranto et al., 2005)

Researchers (Curran et al., 2005; Taranto et al., 2005; Wilkinson et al., 1995; Sadeghi et al., 2000), state that there is no significant difference between healthy adolescent's footprints and borderline, thus normal gait's angle parallels to sagittal plane.

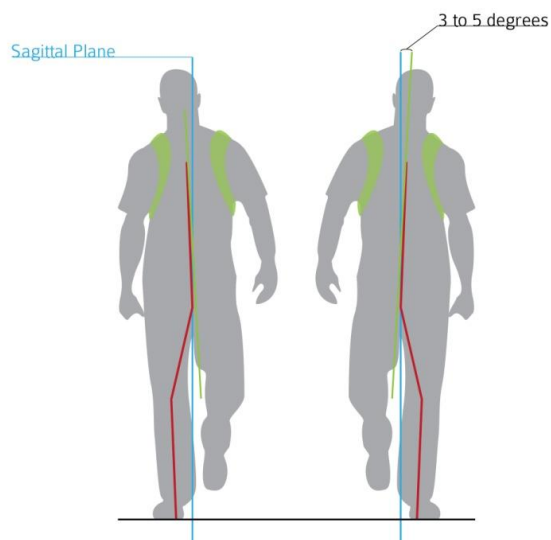

Figure 12. Posture's plane during walking

Pauwels (1984), proved that the mechanical axis deviations in the lower extremity generally arises instant or iterative disbalance or/and sprain, and causes deformity in the lower extremity, anterior knee pain and / or patellofemoral pain.

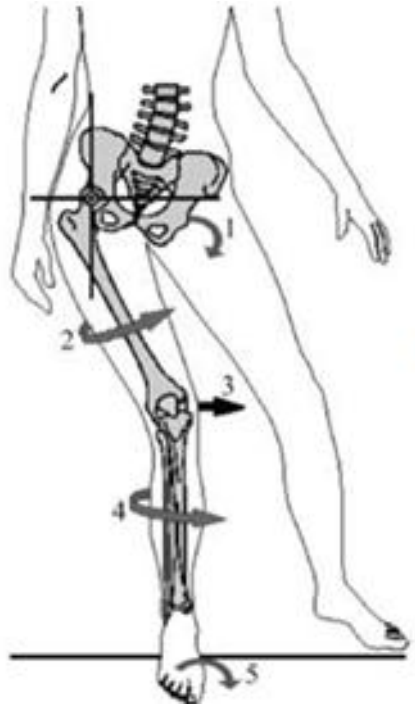

Figure 13. Axis Deviations

CHAPTER 3

STRAIGHT LINE MECHANISMS

The branch of scientific analysis which deals with motions, time, and forces is called mechanics and made up of two parts, statics and dynamics (Shigley & Uicker, 1995). Dynamics is also made up of kinetics and kinematics. Kinematics is the study of motion without regard forces; kinetics is the study of forces on systems in motion (Norton, 2004). This thesis deals only kinematic analysis.

Mechanisms are kinematic chains that constructed by links that connected by joints. These connections, joints between the links, are called kinematic pairs.

Table 1. Kinematic pairs
(Source: Korkmaz, 2004)

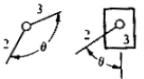
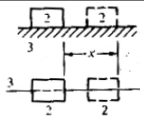
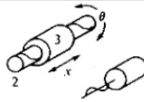
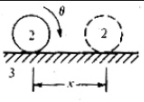
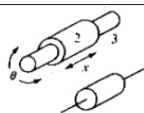
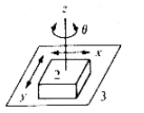
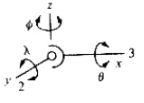
TYPE	SCHEMATIC	MOTION	DESCRIBING QUANTITY	DEGREE OF FREEDOM
REVOLUTE		Rotation	θ	1
PRISMATIC		Sliding	x	1
HELICAL		Rotation and translation	θ or x	1
ROLLING (No slip) (With Slip)		Rotation and translation	θ or x θ and x	1 2
CYLINDRIC		Rotation and sliding	θ and x	2
PLANAR		x,y translation and rotation about z axis	x,y and θ	3
GLOBAL		Rotation about x,y and z axes.	$\phi, \lambda,$ and θ	3

Sometimes a point on self recording instrument is required to move in a straight line. The obvious way of doing this is to use a sliding pair. But sliding pairs are bulky and gets rapidly worn out, so that certain circumstances, it is desirable to obtain straight line motion by the use of turning pairs. A mechanism which produces straight line motion by using turning pairs is known as straight line motion mechanism (Phakatkar 2009).

Straight line motion mechanism is a very common application of coupler curves is the generation of approximate straight lines (Norton, 2004). Accomplishment of exact rectilinear motion is practically impossible for a four-bar linkage. There are numerous mechanisms which approximately achieve rectilinear motion on a segment. They are mostly mechanisms in which the coupler curve is symmetrical, and the point on the working part (coupler) whose motion is observed lies on the direction normal to the direction of the support and it coincides with its centre line, which is at the same time the centre line of the coupler curve (Bulatovic´ & Dordevic´, 2009).

Many kinematicians such as Watt, Chebyshev, Peaucellier, Kempe, Evans, and Hoeken (as well as others) over a century ago, developed or discovered either approximate or exact straight-line linkages, and their names are associated with those devices to this day (Norton, 2004).

3.1. Watt's Straight Line Mechanism

The first person who investigated straight line mechanism was James Watt. Watt's straight line mechanism, invented in 1784 (Ferguson, 1962a), shown in *Figure 14*, consists of three movable rigid bodies labelled DE, EB and BC connected with pin joints at D, E, B and C. The pin joints at D and C connect the bodies to a fixed base-frame while the joints at E and B can freely move about in a plane. Point F is the midpoint of BE. The lengths of DE and BC are equal. As BC is rotated about C, point F traces an approximate vertical straight line in a small segment of its locus.

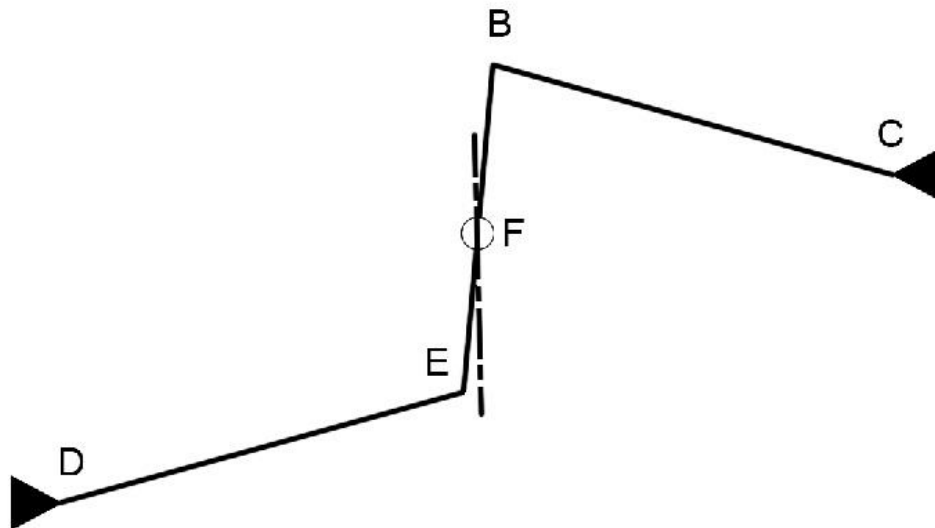

Figure 14. Watt's approximate straight-line linkage.

Because of this linkage does not generate a true straight line motion, it is also called “Watt’s parallel motion mechanism” (Pennock, 2007).

3.2. Evans’ Straight Line Mechanism

The first of the non-Watt four-bar linkage invented by Oliver Evans in 1805, modified from Scott Russell linkage (Ferguson, 1962a).

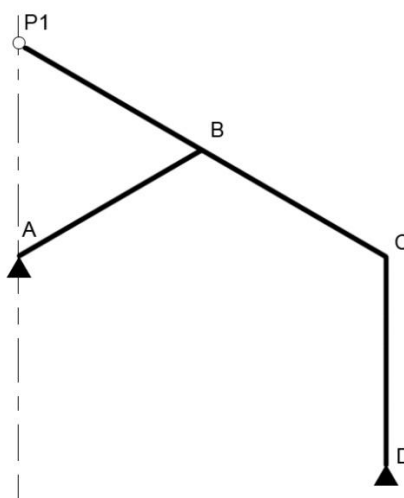

Figure 15. Evans’ Straight Line Mechanism

Evans' linkage has an oscillating drive-arm that should have a maximum operating angle of about 40° . For a relatively short guide way, the reciprocating output stroke is large. Output motion is on a true straight line in true harmonic motion. If an exact straight-line motion is not required, a link can replace the slide. The longer this link, the closer the output motion approaches that of a true straight line. If the link-length equals the output stroke, deviation from straight-line motion is only 0.03% of the output stroke (Sclater, 2001).

3.3. Robert's Straight Line Mechanism

First closer approximate straight line mechanism was discovered by Richard Roberts around 1820 (Ferguson 1962a).

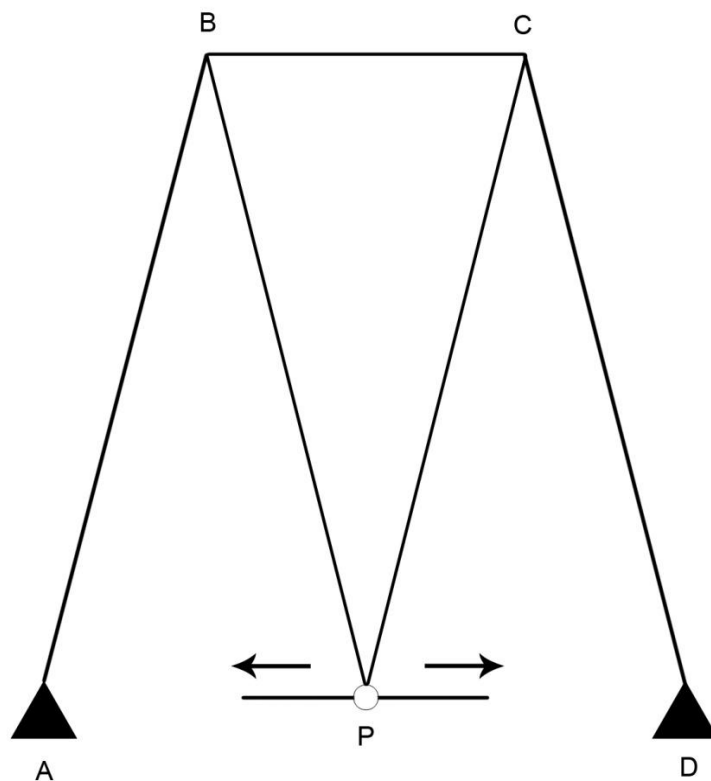

Figure 16. Robert's Straight Line Mechanism

The radial bars are of equal length, the distance between the fixed pivots is twice that of the pivots on the traversing piece, and the tracer is situated on the traversing piece,

at a distance from the pivots on it equal to the lengths of the radial bars. The tracer in consequence coincides with the straight line joining the fixed pivots at those pivots and half-way between them. The path described by the tracer when it passes the pivots altogether deviates from the straight line (Kempe, 2008).

3.4. Chebyshev's Straight Line Mechanism

Russian mathematician Pafnutii L'vovich Chebyshev (Tchebicheff) (1821–1894) of St Petersburg University spent many years investigating the problem of the number of links necessary to draw exact mathematical curves. There is some evidence that he had proved that a five link mechanism could not draw an exact straight line. He invented several approximate straight-line devices himself (Ferguson, 1962b).

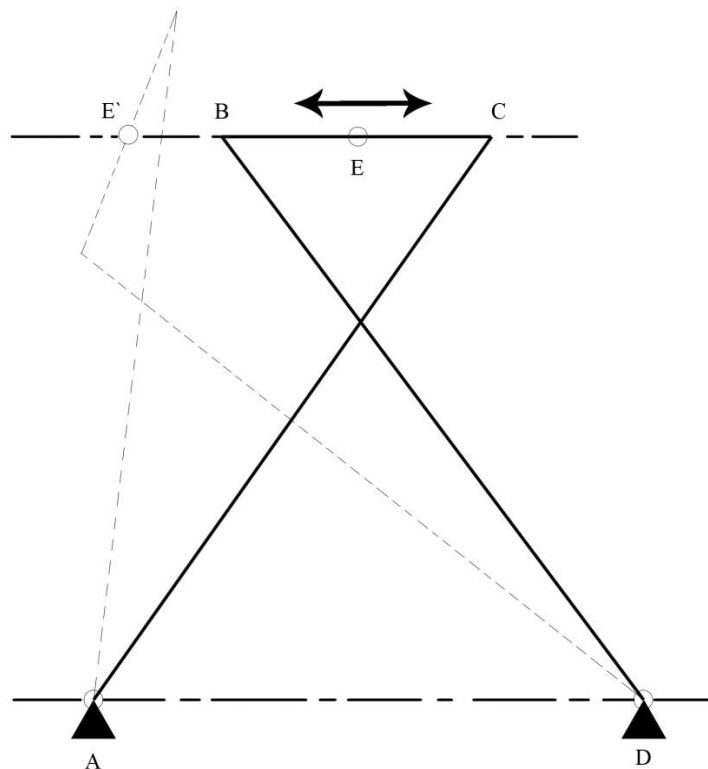

Figure 17. Chebyshev's straight line mechanism

Chebyshev's straight line mechanism is simple in construction. It is a double rocker and the midpoint of the coupler is the point tracing the approximate linear path. Figure 17. schematically pictures Chebyshev's straight line mechanism consisting of

four rigid bodies (links) that are connected to each other by revolute joints. Link lengths of this mechanism are in the proportions $BC=1$ unit, $AC=BD=2.5$ units, and $AD=2$ units (Eckhardt, 1998).

3.5. Peaucellier's – Lipkin's Straight Line Mechanism

An exact straight-line planar linkage was invented in 1864, when Charles-Nicholas Peaucellier finally synthesized the exact straight-line linkage that bears his name. The Peaucellier straight-line linkage is a more complex linkage than the four bar and has eight members and six joints, four of which are ternary joints (Pennock, 2007).

Later a Russian, Lipkin a student of Chebyshev, independently invented the same straight-line mechanism and was awarded a Russian prize for the effort only to discover that Peaucellier had published the idea a few years earlier (Moon, 2007).

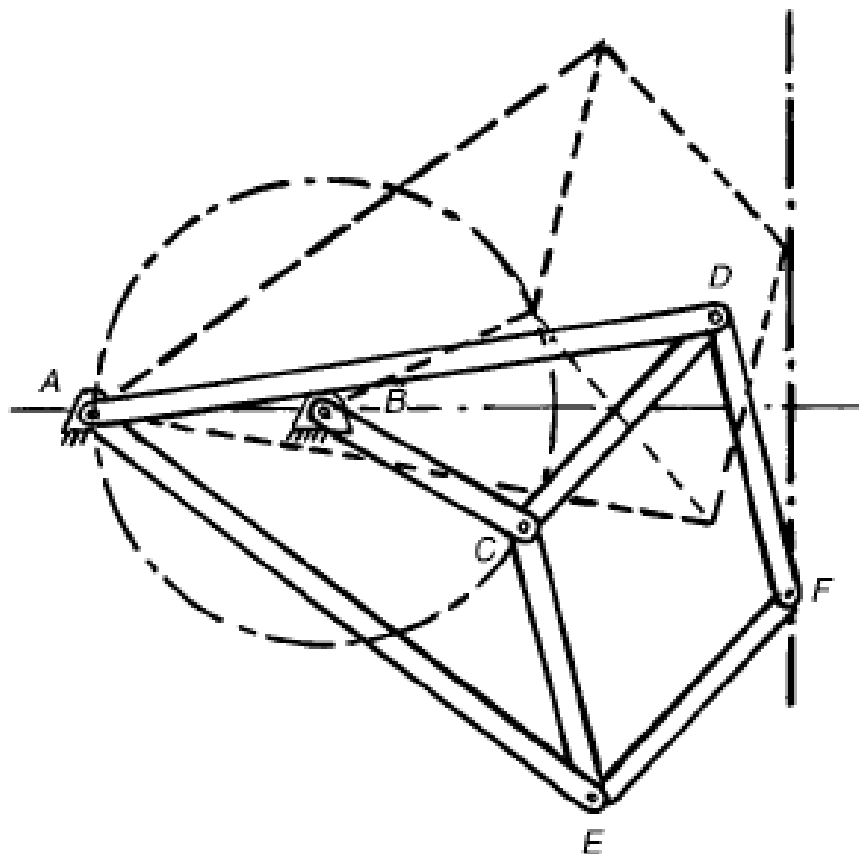

Figure 18. Peaucellier's Straight line mechanism
(Source: Ferguson, 1962a)

The “Peaucellier cell” was the first solution to the classical problem of generating a straight line with a linkage. Within the physical limits of the motion, $AC \times AF$ remains constant. The curves described by C and F are, therefore, inverse; if C describes a circle that goes through A, then F will describe a circle of infinite radius a straight line, perpendicular to AB. The only requirements are that: $AB = BC$; $AD = AE$; and CD, DF, FE, EC be equal. The linkage can be used to generate circular arcs of large radius by locating A outside the circular path of C.

3.6. Hoeken’s Straight Line Mechanism

A rigid body Hoeken linkage is shown in Figure 19. It comprises four rigid links connected by hinge joints. As the crank (I) is moved through a full rotation, a point O on the coupler traces a closed path P , which has a substantial straight line segment (Rai et al., 2010).

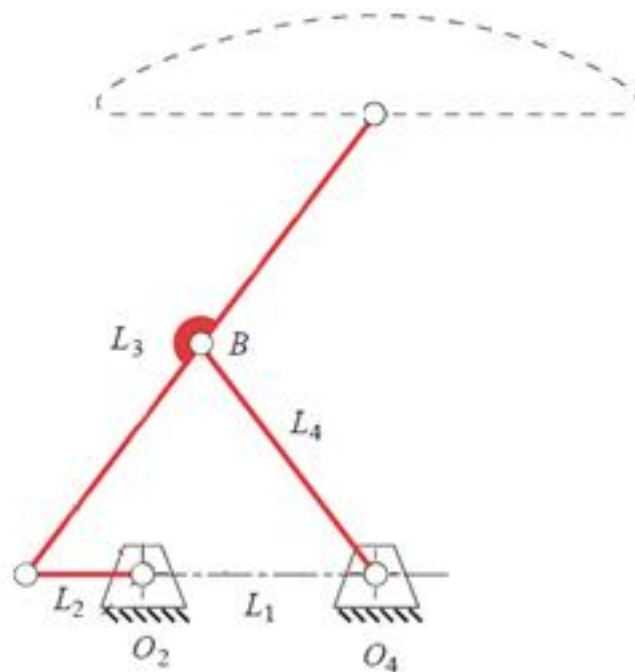

Figure 19. Hoeken’s straight line linkage
(Source: Norton, 2004)

The Hoeken linkage is a Grashof crank-rocker, which has the feature of very nearly constant velocity along the centre portion of its straight-line motion (Norton, 2004). In the Hoeken's four-bar linkage, the coupler point also traces rectilinear motion, the coupler curve is symmetrical, and the centre line of the coupler curve passes through the point of rocker support. This linkage satisfies the Grashof conditions, the crank is the shortest member and during a working cycle it describes a complete circle (Bulatovic' & Dordevic', 2009). The coupler and the rocker have the same lengths. Link lengths of this mechanism are in the proportions $L_2=1$ unit, $L_3/2=L_4=2.5$ units, and $L_1=2$ units.

3.7. Designing Multi-loop Linkages

A kinematic chain is defined as an assemblage of links and joints, interconnected in a way to provide a controlled output motion in response to a supplied input motion (Norton, 2004). A kinematic chain can also be called as a single-loop linkage is shown in Figure 20, so mechanism has more than one kinematic chain can be called as a multi-loop linkage is shown in Figure 21.

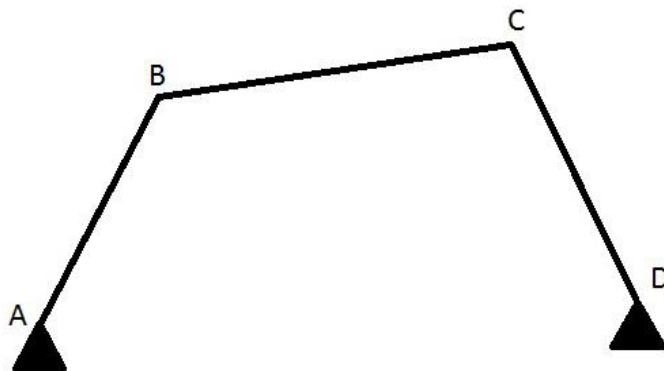

Figure 20. A Single-loop Linkage

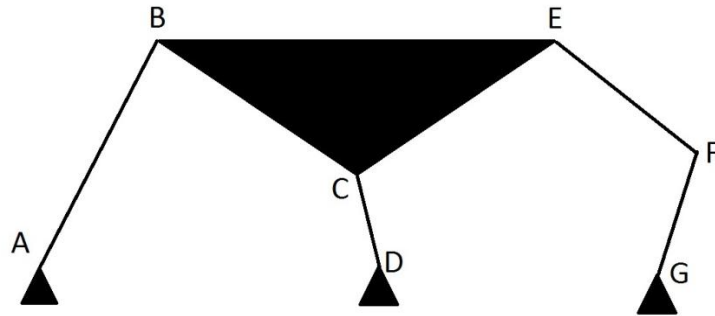

Figure 21. A Multi-loop Linkage

Eckhardt (1998) says,

Often, a multi-loop linkage can be developed quite naturally by combining individual simpler loops and their features.

A basic motion that has many or most of the characteristics desired for a given application can be provided by a simple four-bar linkage. A multi-loop linkage can be acquired by extending a four-bar linkage by adding more links to provide an additional output occurs when some additional motion provided and that motion must be synchronized with the motion of the original four-bar linkage. In such a case, the motion of some point in the original four bar linkage often can be borrowed and used as a input to move the added links.

Designing a multi-loop mechanism, determining the needs of desired output motion is the most important part. Also, one of the most important needs of a mechanism is determining its degree of freedom (mobility). Hunt (1978) defined the connectivity between two specific members of a kinematic chain as the relative mobility between them. Degree of Freedom is the number of inputs that need to be provided in order to create a predictable output (Norton, 2004).

4 can be calculated by Gruebler's equation:

$$\text{DOF} = 3(L-1) - 2J_1 - J_2 \quad (3.1)$$

Where:

DOF: degree of freedom of the mechanism,

L: number of links,

J_1 : number of joints, those that allow only one degree of relative motion,

J_2 : number of joints, those that allow only two degree of relative motion.

CHAPTER 4

A PROPOSAL FOR DERIVED MECHANISM FROM HOEKEN'S STRAIGHT LINE LINKAGE

4.1. Problems of FE02 Stepper's Mechanism

FE02 Stepper is outdoor fitness equipment used to tone lower body while raising heart rate and helping to increase cardiovascular fitness via simulating step-up motion. Step-up exercises have been suggested for strengthening the hip abductor muscles and improving balance in older adults (Sherrington et al., 2004; Steadman et al., 2003).



Figure 22. FE02 Stepper (Modelling by Senkron Fitness & Medical Products Manufacturing & Marketing Co.).



Figure 23. FE02 Stepper and exercise

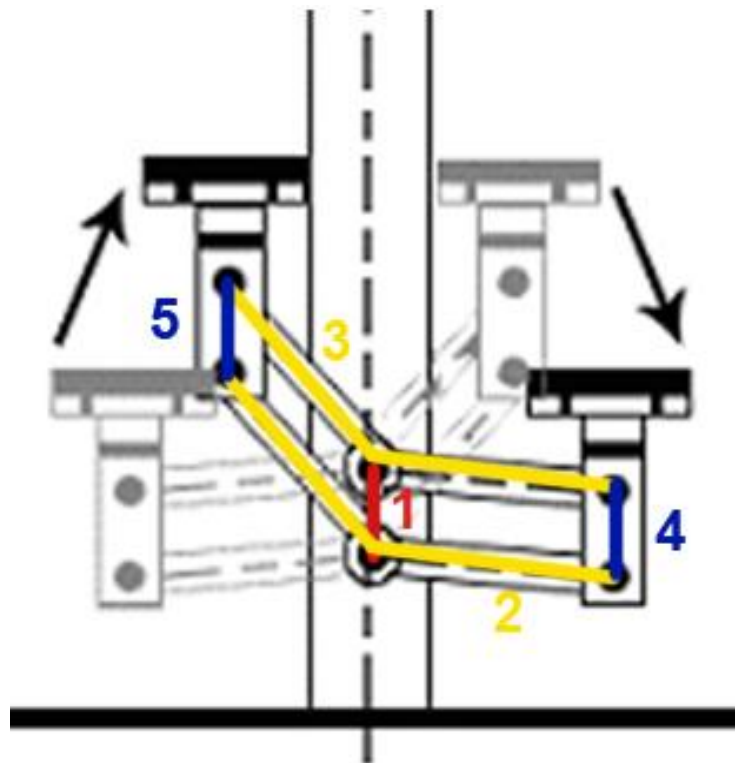

Figure 24. FE02 Stepper's mechanism

FE02 Stepper's mechanism is a parallel motion linkage which is modified for the task. The modification was made at second and 3th links; they were lengthened. One additional link, 5th link, was added for second foot and by this way a five bar mechanism was obtained.

Degree of freedom of FE02 Stepper's mechanism is:

$$M = 3(n-1) - 2x_f + q \quad (4.1)$$

$$M = 3(5-1) - 2 \times 6 + 1 = 1$$

In this equation, q represents the additional link which doesn't affect the output motion but it is a necessity for stepper's function.

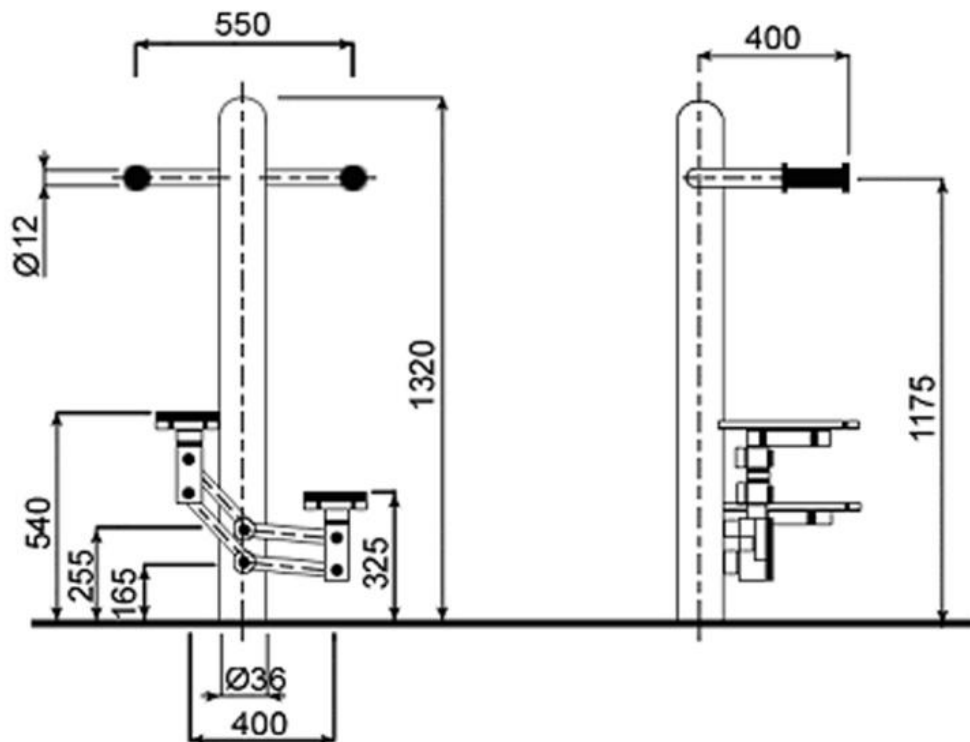

Figure 25. FE02 Stepper Technical Drawing (mm)

First of all, according to Panero & Zelnik (1979), the riser height must be 17 cm. At FE02 stepper, the users' first step height is 32,5 cm, the during exercise steps height is 21,5 cm and these values are unsafely in the context of ergonomic data. Hence, these values must be corrected and reset to 17 cm.

Step height is not the only problem, as it can be seen in Figure 24, FE02 stepper's mechanism output motion is angled too, indeed and the angle between two positions is $3,54^\circ$. It means, during exercise, the leg which is unbend and full pushed down must make extra $3,54^\circ$ hip abduction. When the left and right foot height from the ground are equal, the angle between two leg is 33° , that means the angle between leg and sagittal plane is $16,5^\circ$; at full pushed down, the unbend leg becomes as possible as parallel to sagittal plane for balancing the body, and the angle between bended and unbend legs becomes 33° . According to scientific researches, angle of internal rotation in flexion angle is maximum 30° (see chapter 2.4.). Because of these limits and the body should keep the balance, bended leg makes internal and external rotations in knee flexion, ankle inversion and dorsiflexion in addition to hip and knee flexion. While, the unbend leg becomes as possible as parallel to sagittal plane for balancing the body, it can be seen that (see Figure 26) both legs make internal and external rotations which constrains knee tendons and ligaments. In this exercise, tensile of knee tendons and ligaments doesn't cause instant injuries but in long term usage, may cause soft tissue damage and pain.



Figure 26. Leg's appearance during exercise

When the angles were calculated, it can be seen that the lower extremity reaches $25,89^\circ$ (see Figure 27.). In Figure 28., the over-strain can be seen easily which causes mostly sprain. During exercise, although the movement is kept under control and in limitations and sprain is precluded, injury risk still exists.

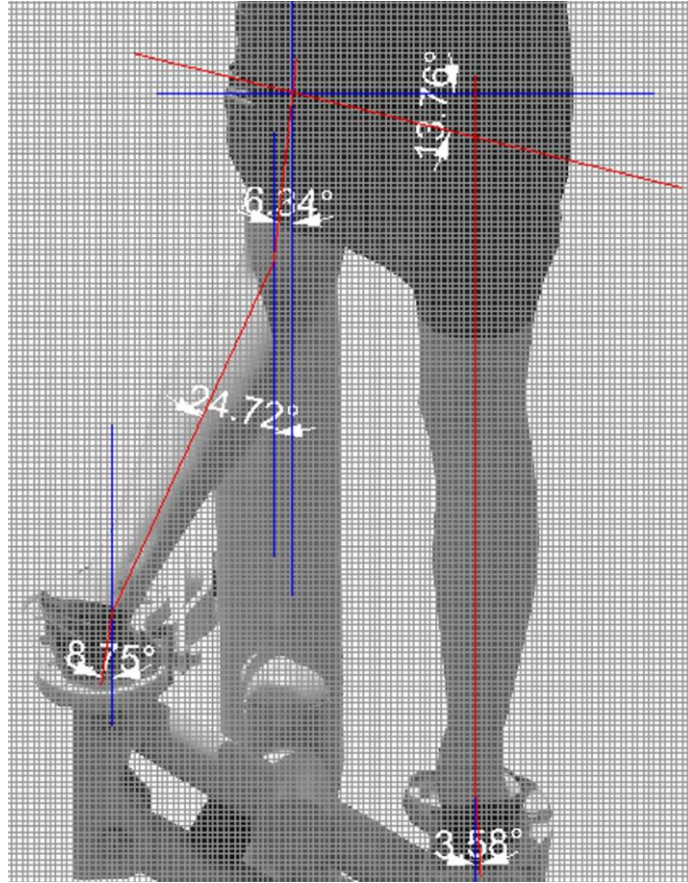

Figure 27. Angles during exercise



Figure 28. Ankle over-strain

One of the achievements of designing outdoor fitness equipment should be providing safety. In the context of FE02 stepper's design, for achieving this goal, output motion should be compatible with normal human step-up motion. Although lower extremity is able to do angled motions, the normal step-up motion occurrences parallel to sagittal plane and lower extremity doesn't make rotations (see Chapter 2). Therefore output motion should be straight and doesn't force the lower extremity to internal and external rotations in knee flexion, ankle inversion and dorsiflexion.

4.2. Design of FE02 Stepper's New Mechanism

New mechanism's mobility should be 1 as current mechanism. Also new mechanism's links shouldn't be over range the feet alignments and attachment points of links shouldn't be at the same level with feet alignments. Besides that, simplicity is preferred in machine design and it should be considered that chosen straight line linkage should be modified for both foot, so modifying any pin-jointed four bar mechanism would be more cost and production friendly.

If straight line linkages are evaluated; it can be seen that Watt's and Chebyshev's mechanisms' links are over range, Evan's and Robert's mechanisms' attachment points of links are at the same level with feet alignments. Peaucellier straight-line mechanism's links are in range and there is no attachment points of links at feet alignments but is a more complex linkage than the four bar; it has eight links. Hoeken's straight line mechanism is the one that suits the criterions.

Hoeken's straight line mechanism and its mirror image could be interlinked for both foot usages, so a multi-loop mechanism could be obtained. The important part is deciding to which links should be used in common for merging. Since both of the mechanisms should be attached at same surface, the grounded link is common, and one more link is needed for keeping motion flow and mobility 1.

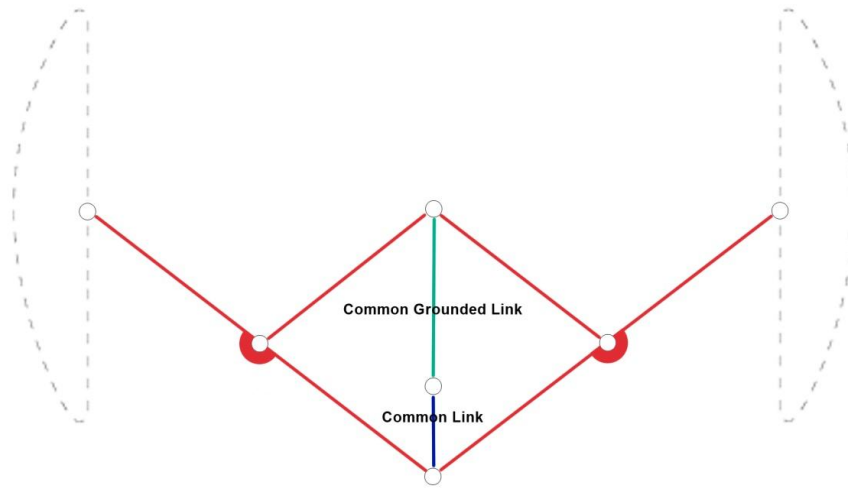

Figure 29. Merging Two Hoeken's Straight Line Linkage

Degree of freedom of FE02 Stepper's new mechanism is:

$$M = 3(6-1) - 2 \times 7 = 1$$

Hoeken's straight line mechanism draws approximate straight line, but substantial straight line segment can be obtained by corrections of errors in straightness. A study was done to determine the errors in straightness of the Hoeken-type linkage by Norton (2004), these values was used to determine measurements of links.

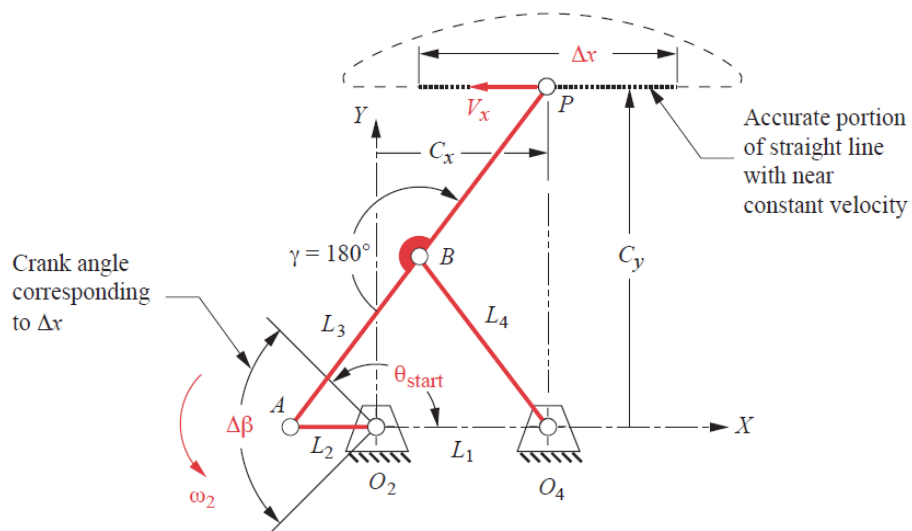

Figure 30. Hoeken Linkage
(Source: Norton, 2004)

Table 2. Link Ratios for Smallest Attainable Errors in Straightness
(Source: Norton, 2004)

Range of Motion			Optimized for Straightness					
$\Delta\beta$ (deg)	θ_{start} (deg)	% of cycle	Maximum ΔC_y %	ΔV %	$\frac{V_x}{(L_2 \omega_2)}$	Link Ratios		
						L_1 / L_2	L_3 / L_2	$\Delta x / L_2$
20	170	5.6%	0.00001%	0.38%	1.725	2.975	3.963	0.601
40	160	11.1%	0.00004%	1.53%	1.717	2.950	3.925	1.193
60	150	16.7%	0.00027%	3.48%	1.702	2.900	3.850	1.763
80	140	22.2%	0.001%	6.27%	1.679	2.825	3.738	2.299
100	130	27.8%	0.004%	9.90%	1.646	2.725	3.588	2.790
120	120	33.3%	0.010%	14.68%	1.611	2.625	3.438	3.238
140	110	38.9%	0.023%	20.48%	1.565	2.500	3.250	3.623
160	100	44.4%	0.047%	27.15%	1.504	2.350	3.025	3.933
180	90	50.0%	0.096%	35.31%	1.436	2.200	2.800	4.181

Since accurate portion of straight line should be 17 cm, links should be calculated according to this value and range of motion is 180°:

$$\Delta x / L_2 = 4,181 \quad (4.2)$$

$$L_2 = 17 / 4,181 = 4,0660$$

$$L_1 / L_2 = 2,200 \quad (4.3)$$

$$L_1 = 2,200 \times 4,0660 = 8,9452$$

$$L_3 / L_2 = 2,800 \quad (4.4)$$

$$L_3 = 2,800 \times 4,0660 = 11,3848$$

$$L4 = L3/2 \quad (4.5)$$

$$L4 = 11,3848/2 = 5,6924$$

4.3. Position Analysis of FE02 Stepper's New Mechanism

The position analysis of a kinematic chain requires the determination of the kinematic pair positions. The position of a point in the plane can be defined by the use of a position vector.

4.3.1. Algebraic Position Analysis

Algebraic Position Analysis is the classical approach of analysing the links' positions via geometrical relations. For any one-DOF linkage, such as a four bar, only one parameter is needed to completely define the positions of all the links (Norton, 2004). The parameter usually chosen is the angle of the input link.

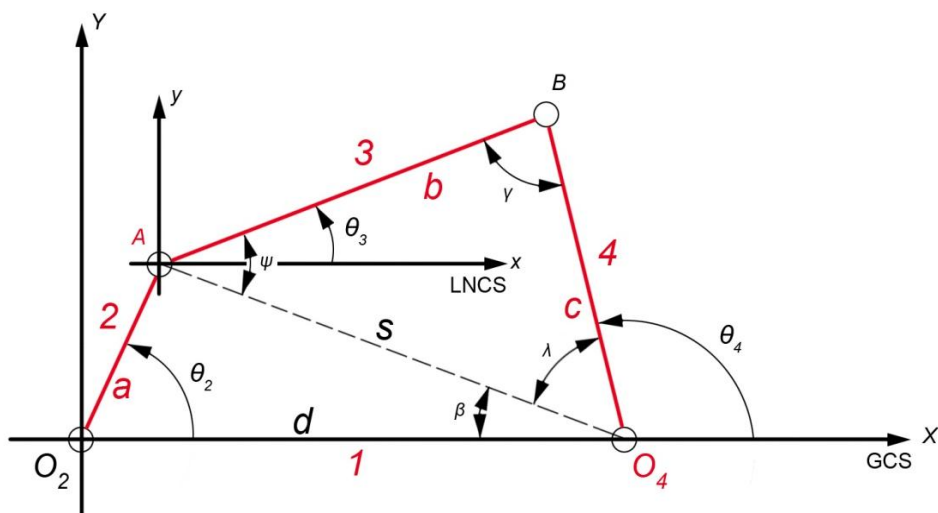

Figure 31. Measurement of angles in the four-bar linkage

The angles must be measured as the counter clockwise angle from the x coordinate to the link.

The coordinates of point A are found from:

$$A_x = a \cos \theta_2 \quad (4.6)$$

$$A_y = a \sin \theta_2 \quad (4.7)$$

The coordinates of point B are found from:

$$b^2 = (B_x - A_x)^2 + (B_y - A_y)^2 \quad (4.8)$$

$$c^2 = (B_x - d)^2 + B_y^2 \quad (4.9)$$

so;

$$B_x = \frac{a^2 - b^2 + c^2 - d^2}{2(A_x - d)} - \frac{2A_y B_y}{2(A_x - d)} \quad (4.10)$$

$$B_y = c^2 - \left(\frac{a^2 - b^2 + c^2 - d^2}{2(A_x - d)} - \frac{A_y B_y}{A_x - d} - d \right)^2 \quad (4.11)$$

Solving for θ_2 gives:

$$\theta_2 = \cos^{-1} \frac{B_x^2 + a^2 - b^2}{2B_x a_2} \quad (4.12)$$

$$\beta = \cos^{-1} \frac{d^2 + s^2 - a^2}{2ds} \quad (4.13)$$

$$\psi = \cos^{-1} \frac{b^2 + s^2 - c^2}{2bs} \quad (4.14)$$

$$\lambda = \cos^{-1} \frac{c^2 + s^2 - b^2}{2cs} \quad (4.15)$$

There will generally be two values of λ corresponding to each value of θ_2 . If θ_2 is in the range $0 \leq \theta_2 \leq 180$, the unknown directions are taken as;

$$\theta_3 = \psi - \beta \quad (4.16)$$

$$\theta_4 = 180 - \lambda - \beta \quad (4.17)$$

However, if θ_2 is in the range $180 \leq \theta_2 \leq 360$, then;

$$\theta_3 = \psi + \beta \quad (4.18)$$

$$\theta_4 = 180 - \lambda + \beta \quad (4.19)$$

and,

$$\gamma = \pm \cos^{-1} \frac{b^2 + c^2 + s^2}{2bc} \quad (4.20)$$

These equations could be implemented in Microsoft Excel 2007[®]:

Table 3. Link 2

L2					
L2	4,066			L1	8,9452
coordinates of point O2		Degree	coordinates of point A		
X	Y		X	Y	
0	0	200	-3,8207902	-1,3906539	

Table 4. Link 3

L3				
L3	11,3848			
coordinates of point A		Degree	coordinates of point E	
X	Y		X	Y
-3,8207902	-		6,90896224	18,6923513
	1,3906539			

Table 5. Link 4

L4

L3		11,3848		
coordinates of point O1		Degree	coordinates of point B	
X	Y		X	Y
8,9452	0	130,548185	1,54408602	8,65084868

Table 6. Link 5

L5

L5		11,3848		
coordinates of point O1		Degree	coordinates of point F	
X	Y		X	Y
8,9452	0	118,114265	3,58032378	-10,041503

Table 7. Link 6

L6

L6		11,3848		
coordinates of point A		Degree	coordinates of point G	
X	Y		X	Y
-	-		10,9814378	-18,692351
3,8207902	1,3906539			

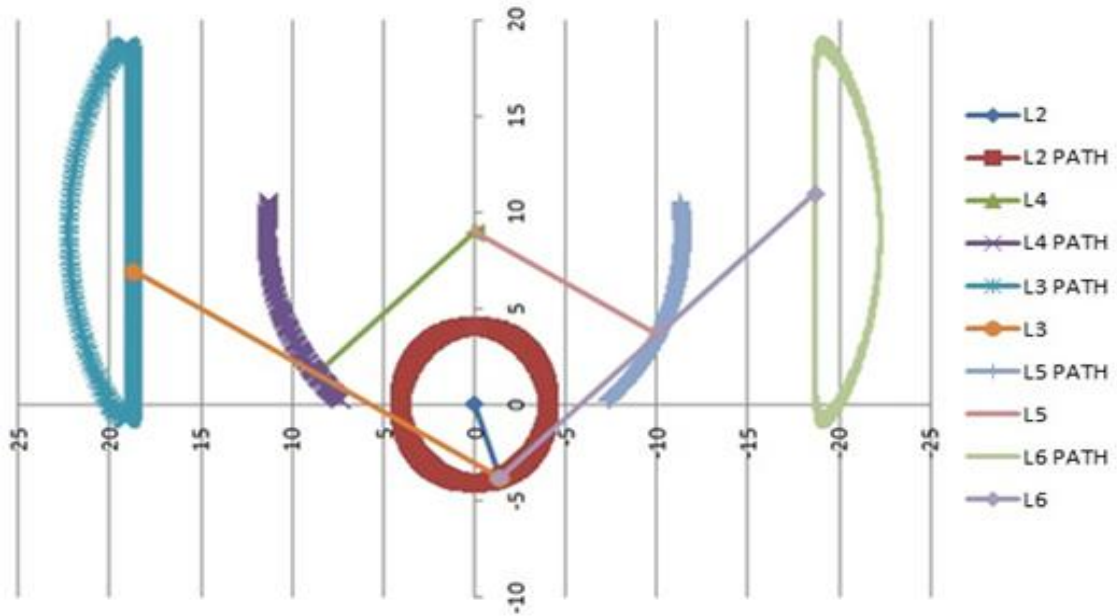

Figure 32. Graph of new mechanism's geometrical trajectory

When L3 Path and L6 Path were inspected, it was seen, between θ_2 values of 72° and 297° , geometrical trajectory is almost straight.

Once the new mechanism's output motion was approved, the new mechanism and new stepper design modeled by using Rhinoceros Evolution v4.0[®].

Besides designing a new mechanism, FE02 Stepper's presented other design failures that should be corrected to satisfy the users. In this step of the re-design process, brainstorming and simulation and modeling research were commonly used to add new product features. According to results:

- FE02 Stepper is outdoor fitness equipment so the users of the product should be protected from negative weather conditions. In order to protect them from sunlight and rain, a roof was added to the design.
- To prevent misuse of the product and inform user about the purpose of the product, a plate user guide attached to the product at the eye level.
- FE02 Stepper has a metal body that is coated by cathoporesis treatment and painting for anti-corrosion. Despite these anti-corrosion treatments, FE02 Stepper still needs high cost corrosion maintenance. This high cost could be avoided using of a different material such as PBT (Polibutilen Tereftalat). And also the surfaces which interact

with the user's body such as hand folds could be coated with Elastomers, such as rubber or silicone.

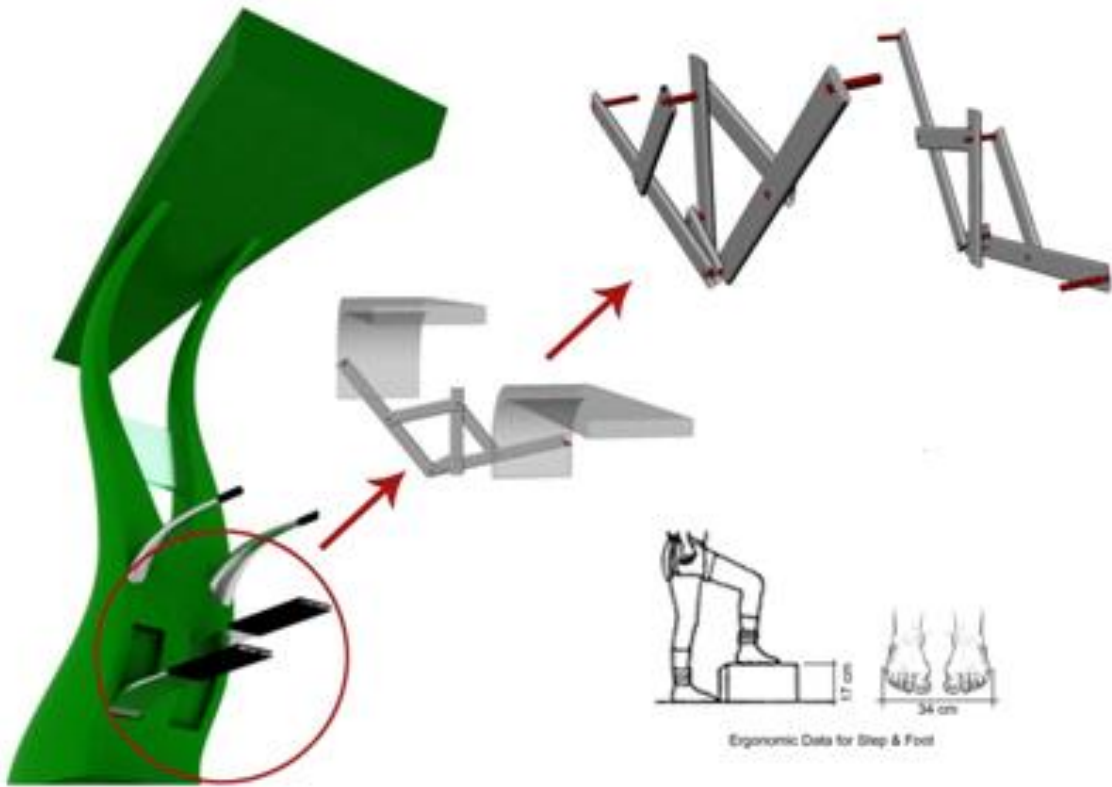

Figure 33. Re-design of FE02 Stepper

CHAPTER 5

CONCLUSIONS

The relation of products to users has become a central theme of design discourse (Margolin, 1997). Hence, designers started to learn how to apply ergonomics, antropometrics and biomechanics into design process. So that, the addition of user concerns to the list of factors that a designer must consider in developing a product has now made product design a much more difficult and demanding task than it once was (Margolin, 1997). Although this difficulty, considering the factors that relative to users is a must. The increased interest in users and their experiences must, however, also be understood in the light of designs failing to get approval by users and situations where the intended use of designs does not translate into actual used and how the design community has responded to this. A major response to designs failing to gain approval and acceptance has been to consider it to be a matter of insufficient knowledge about people, their capacities, needs and desires and that design therefore needs to be based on the improvement of such knowledge.

Since, outdoor fitness equipment which is synchronous with their user's movement considering into this study, key points of the user's movement accepted as the main factor. Hence, in this thesis, outdoor fitness equipment, FE02 was corrected in the light of biomechanical and mechanical context.

FE02 Stepper is used to tone lower body via simulating step up motion which is the single complete movement of raising one foot and putting it down. At the first inspection of FE02, it was recognized that steps occur in an angled pattern. Since step up motion is a part of gait, for understanding its nature knee, hip and ankle anatomy and biomechanics were investigated and compared with FE02 Stepper's output motion and it was seen that, the output motion should corrected as straight because according to scientific information, angled step-up motion may cause injuries or / and may have harmful effects. And also while analyzing FE02 Stepper, a design failure, the over height of risers was recognized.

The purpose of correction of output motion could be achieved by designing the new mechanism which was derived from a straight line linkage. The modified linkage,

Hoeken's straight line linkage, was selected after a deep detection of well known straight line linkages.

The start point of the design was modifying Hoeken's linkage for both foot usage and dimensioning the links according to correct riser height. Errors in straightness were corrected based on Norton's (2004) link ratios.

After designing new mechanism, the links' positions and geometrical relations were analysed by using algebraic position analysis method and implemented in Microsoft Excel 2007[®] and the new mechanism's output motion was approved.

Throughout this thesis, the importance of biomechanics and mechanics in design has been showed. This study serves as a starting point for understanding the relationship between industrial design, biomechanics and mechanics. It is recommended that, the future studies should focus to testing the new mechanism's performance.

REFERENCES

- Aclsolutions, *Knee Anatomy*. <http://www.aclsolutions.com/anatomy.php>, 2011
- Blackburn, T. A., & Craig, E. (1980). Knee Anatomy: A Brief Review. *Physical Therapy* , 1556-1560.
- Bulatović, R. R., & Dordević, S. R. (2009). On the optimum synthesis of a four-bar linkage using differential evolution and method of variable controlled deviations. *Mechanism and Machine Theory* , 235-246.
- Curran, S. A., Upton, D., & Lear, I. D. (2005). Dynamic and static footprints: comparative calculations for angle. *The Foot* , 40-46.
- Dabnicki, P. (1998). Biomechanical tests of sport equipment. *Sport Engineering* , 93-105.
- Dananberg, H. J. (2000). Sagittal plane biomechanics. . *American Diabetes Association* , 47-50.
- Donatelli, D. A. (1996, 2nd ed.). *The biomechanics of the foot and ankle*. Philadelphia: F.A. Davis Company.
- Eckhardt, H. D. (1998). *Kinematic Design of Machines and Mechanisms*. McGraw-Hill Professional.
- Ferguson, E. S. (1962a). Kinematics of Mechanisms from the Time of Watt. *United States National Museum Bulletin, No: 228* , 185-230.
- Hatze, H. (1974). The meaning of the term: " Biomechanics". *Journal of Biomechanics* , 189-190.
- Hunt, K. H. (1978). *Kinematic Geometry of Mechanisms*. Oxford: Clarendon Press.
- Imrhan, S. N., Sarder, M. D., & Mandahawi, N. (2009). Hand Anthropometry in Bangladeshis Living in America and Comparisons with Other Populations. *Ergonomics* , 987-998.
- Kempe, B. A. (2008). *How to Draw a Straight Line*. The Project Gutenberg eBook #25155.
- Kernozek, T. W., & Ricard, M. D. (1990). Foot placement angle and arch type: effect on rearfoot motion. *Arch Phys Med Rehabil* , 988-992.
- Knudson, D. (2003). *Fundamentals of Biomechanics*. New York: Kluwer Academic / Plenum Publishers.
- Korkmaz, K. (2004). *An Analytical Study of the Design Potentials in Kinematic Architecture*. Izmir: Izmir Instuyuye of Technology, Faculty of Architecture. Unpublished Phd Thesis.

- Maki, B. E., Edmondstone, M. A., & McIlroy, W. E. (2000). Age-related differences in laterally directed compensatory stepping behavior. *J Gerontol A Biol Sci Med Sci.* , 270-277.
- Maki, B. E., Holliday, P. J., & Topper, A. K. (1994). A prospective study of postural balance and risk of falling in an ambulatory and independent elderly population. *Journal of Gerontology* , 72-84.
- Margolin, V. (1997). Getting to know the user. *Design Studies* , 227-236.
- Marshall, J. L., & Rubin, R. M. (1977). Knee ligament injuries--a diagnostic and therapeutic approach. *Orthop Clin North Am.* , 641-68.
- McIlroy, W. E., & Maki, B. E. (1999). The control of lateral stability during rapid stepping reactions evoked by antero-posterior perturbation: does anticipatory control play a role? *Gait Posture* , 190-198.
- Moon, F. C. (2007). *The Machines of Leonardo Da Vinci and Franz Reuleaux: Kinematics of Machines from the Renaissance to the 20th Century (History of Mechanism and Machine Science)*. Springer.
- Norman, D. A. (2002). *The Design of Everyday Things*. New York: Basic Books.
- Northcoastfootcare, *Foot Anatomy*. <http://www.northcoastfootcare.com/>, 2011
- Norton, R. L. (2004). *Design of Machinery: An Introduction to the Synthesis and Analysis of Mechanisms and Machines*. New York: McGraw-Hill.
- Oatis, C. (1988). Biomechanics of the Foot and Ankle Under Static Conditions. *Physical Therapy* , 1815-1821.
- Panero, J., & Zelnik, M. (1979). *Human Dimensions and Interior Space: A Source Book of Design Reference Standards*. London: The Architectural Press Ltd.
- Pauwels, F. (1980). *Biomechanics of the locomotor apparatus*. New York: Springer-Verlag.
- Pennock, G. (2007). James Watt (1736–1819). *History of Mechanism and Machine Science* , 337-369.
- Phakatkar, H. G. (2009, 4th ed.). *Theory of Machines and Mechanisms I*. Nirali Prakashan.
- Philippon, M. J., Zehms, C. T., Briggs, K. K., Manchester, D. J., & Kuppersmith, D. A. (Operative Techniques in Sports Medicine). Hip and Pelvic Problems in Athletes. 2007 , 189-194.
- Rai, A., Saxena, A., & Mankame, N. (2010). Unified synthesis of compact planar path-generating linkages with rigid and deformable members. *Structural and Multidisciplinary Optimization* , 863-879.
- Reuleaux, F. (1963). *The Kinematics of Machinery*. New York: Dover Publications.

- Riegger, C. L. (1988). Anatomy of Foot and Ankle. *Physical Therapy* , 1802-1814.
- Rogers, M. W., & Mille, M. L. (2003). Lateral stability and falls in older people. *Exerc Sport Sci Rev.* , 182–187.
- S., F. E., & Ferguson, E. S. (1962b). On The Origin And Development Of American Mechanical "Know-How". *American Studies* , 3-16.
- Sadeghi, H., Allard, P., Prince, F., & Labelle, H. (Gait & Posture). Symmetry and limb dominance in able-bodied gait: a review. *2000* , 34-45.
- Sclater, N., & Chironis, N. P. (2001, 3rd ed.). *Mechanisms and Mechanical Devices Sourcebook* . McGraw-Hill.
- Sgarlato, T. E. (1965). Angle of gait. *J Am Podiatry Assoc* , 645-650.
- Sherrington, C., Lord, S. R., & Herbert, R. D. (2004). A randomized controlled trial of weight-bearing versus non-weight-bearing exercise for improving physical ability after usual care for hip fracture. *Arch Phys Med Rehabil* , 710-716.
- Shigley, E. J., & Uicker, J. J. (1995). *Theory of Machines and Mechanisms*. Illinois: McGraw-Hill Companies.
- Steadman, J., Donaldson, N., & Kalra, L. (2003). A randomized controlled trial of an enhanced balance training program to improve mobility and reduce falls in elderly patients. *J Am Geriatr Soc.* , 847– 852.
- Taranto, J., Taranto, M. J., Bryantb, A., & Singerc, K. P. (2005). Angle of gait: a comparative reliability study using footprints and the EMED-SF®. *The Foot* , 7-13.
- Wikipedia *a*, *Human Anatomy Planes*. http://en.wikipedia.org/wiki/File:Human_anatomy_planes.svg, 2011.
- Wikipedia *b*, *Hip Anatomy*. http://en.wikipedia.org/wiki/Muscles_of_the_hip, 2011.
- Wilkinson, M., Menz, H., & Raspovic, A. (1995). The measurement of gait parameters from footprints. *The Foot* , 84-90.