



Commercial Supersonic Noise Considerations

Business/Economics – Addressing Barriers to Future Air Travel

Jon Seidel, NASA Glenn Research Center

SAE International, AEROTECH; March 16-19, 2020; Pasadena, CA



The vision of the Supersonics Community is a future where fast air travel is available for a broad spectrum of the traveling public.

- Future supersonic aircraft will not only be able to fly overland without creating an “unacceptable situation” but compared to Concorde and SST will be efficient, affordable and environmentally responsible

Outline



- Mission/Market Discussion
- Environmental Barriers
- Affordable Approaches to Landing/Take-Off (LTO) Certification Noise

2016 Global Demand Seat distribution (OAG+ 4793 Million Seats)



Within Region = 83%, Inter-Region = 17%

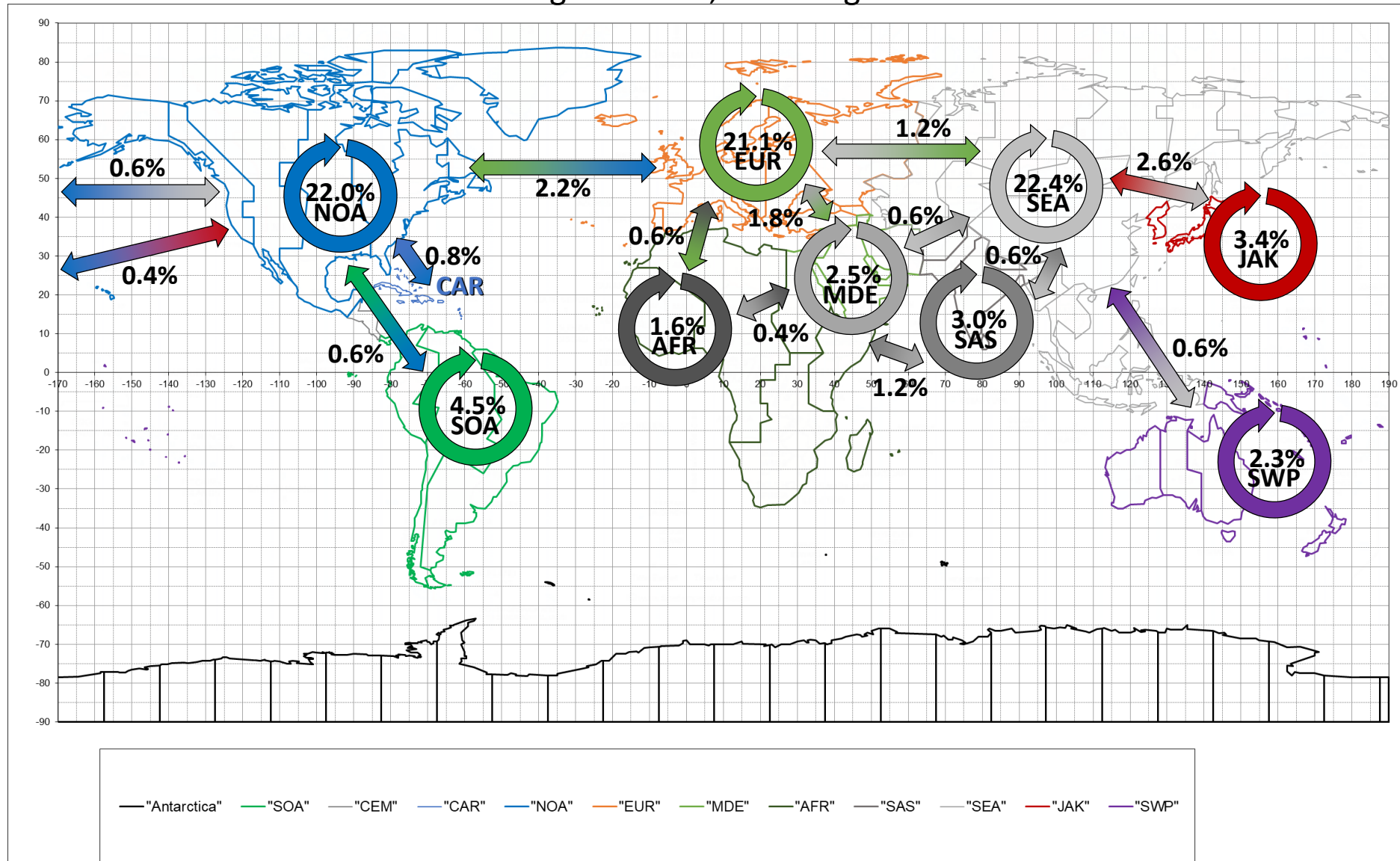

2036 Global Demand Seat distribution (OAG+ 9494 Million Seats)



Within Region = 85%, Inter-Region = 15%

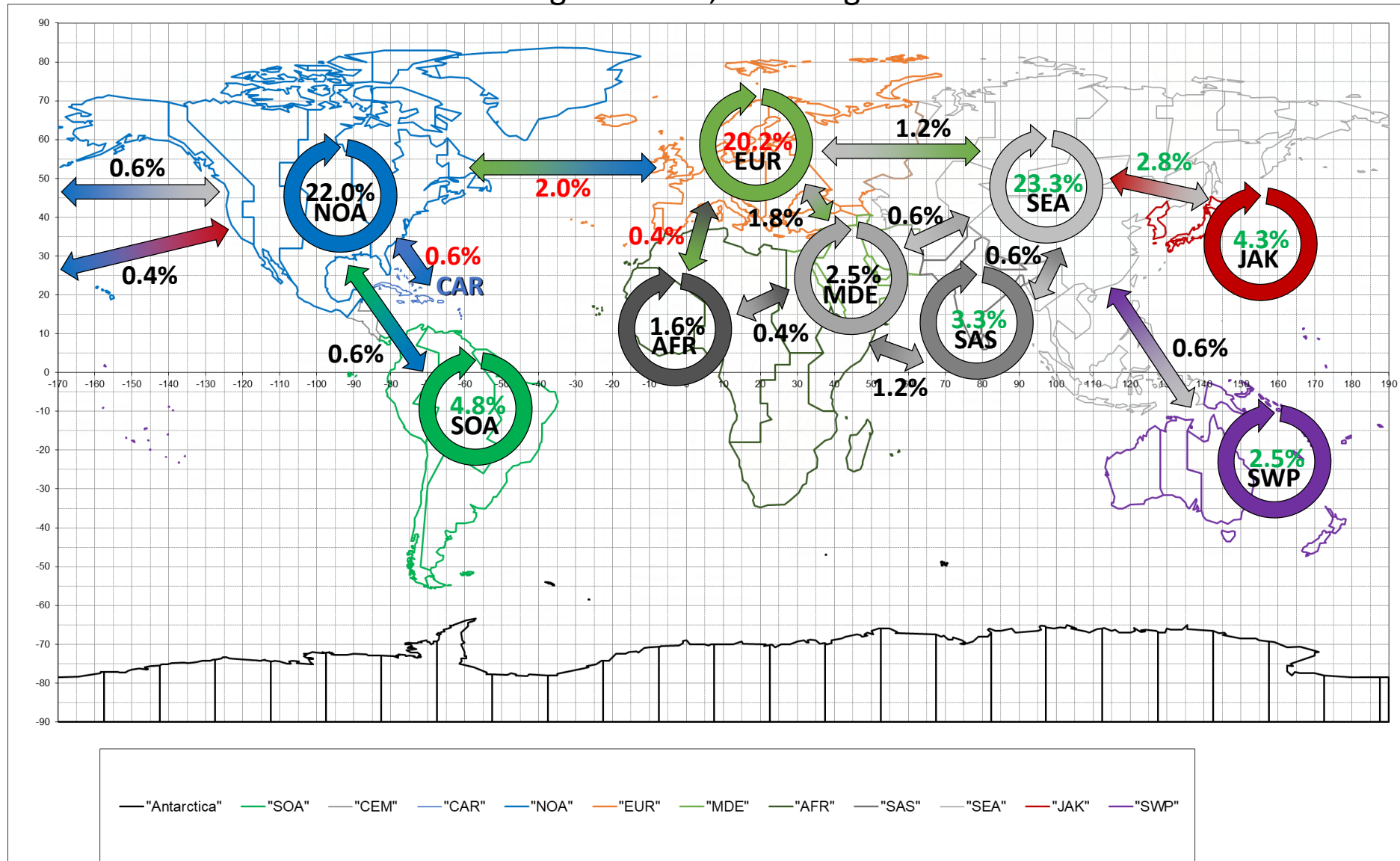



Premium Seat Capture vs. Range and %Overland Distances

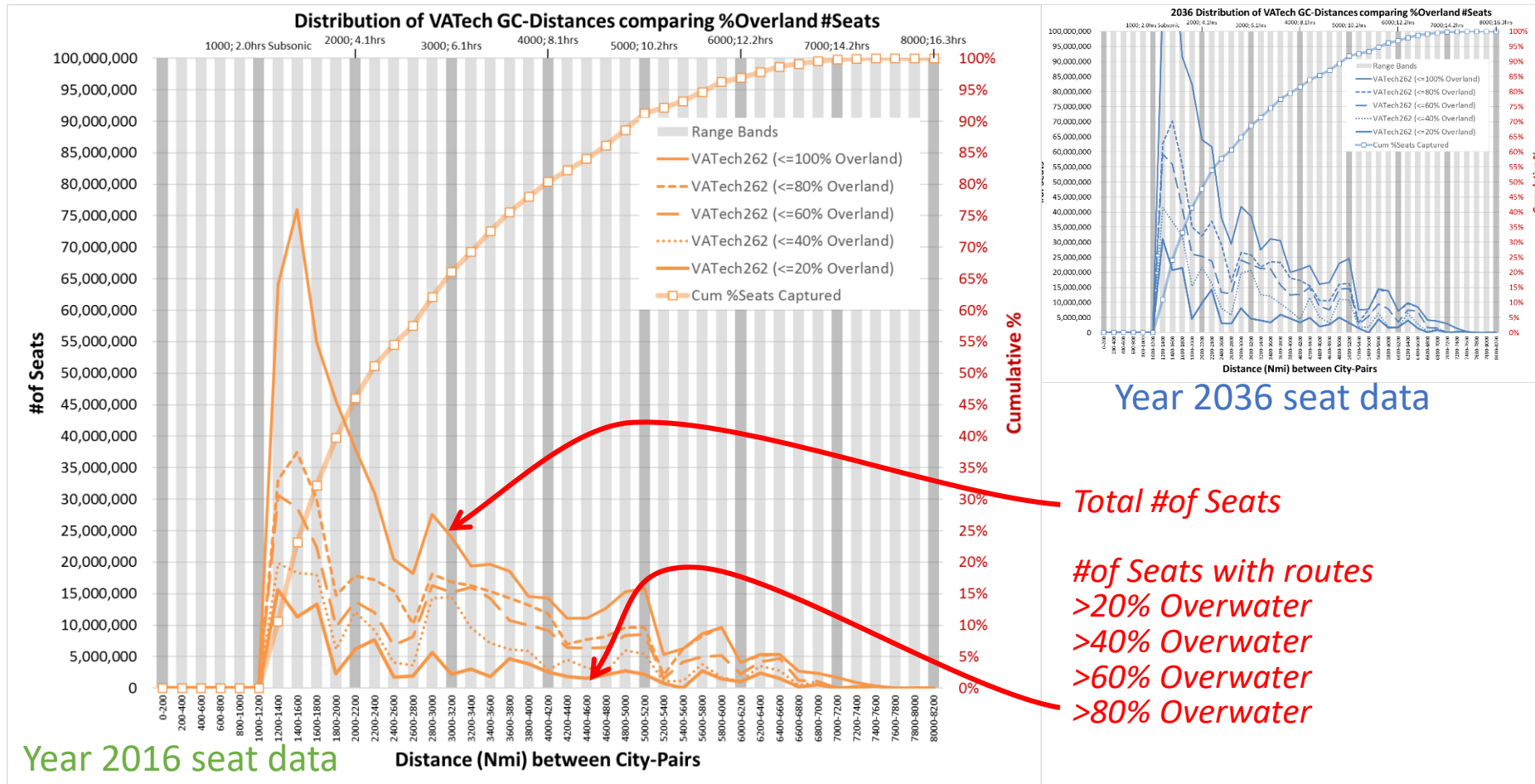

- Without waypoint diversions (GC distances only), most seat traffic is overland for year 2016 traffic data
- Same is true for year 2036 traffic forecast



Premium O-D Capture vs. Range and %Overland Distances

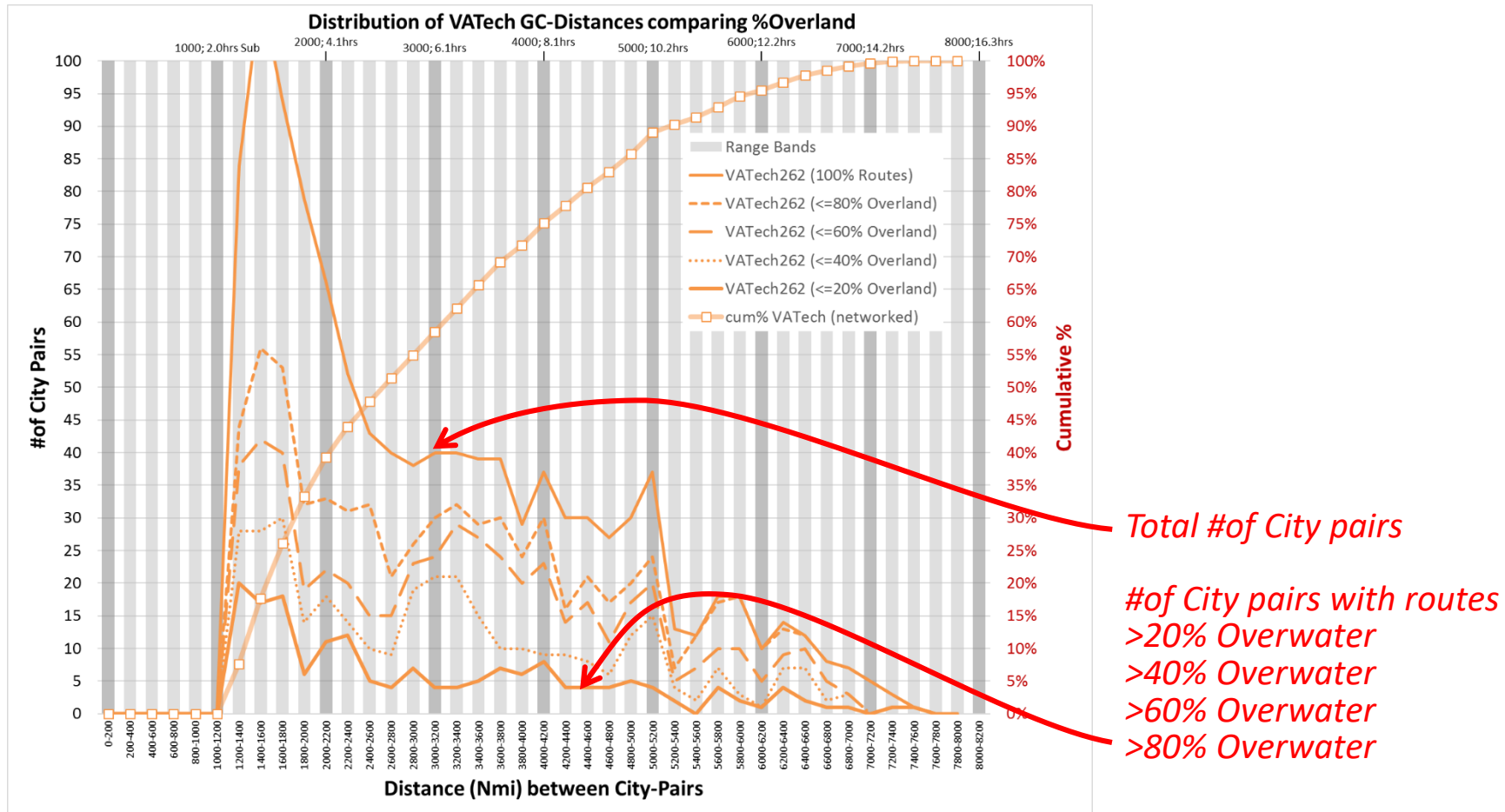

- Without waypoint diversions (GC distances only), most city pairs include substantial overland distances
- Longer range missions generally offer greater opportunity for waypoint diversions to minimize overland distances between city pairs

1200 < Range < 2600 Nmi

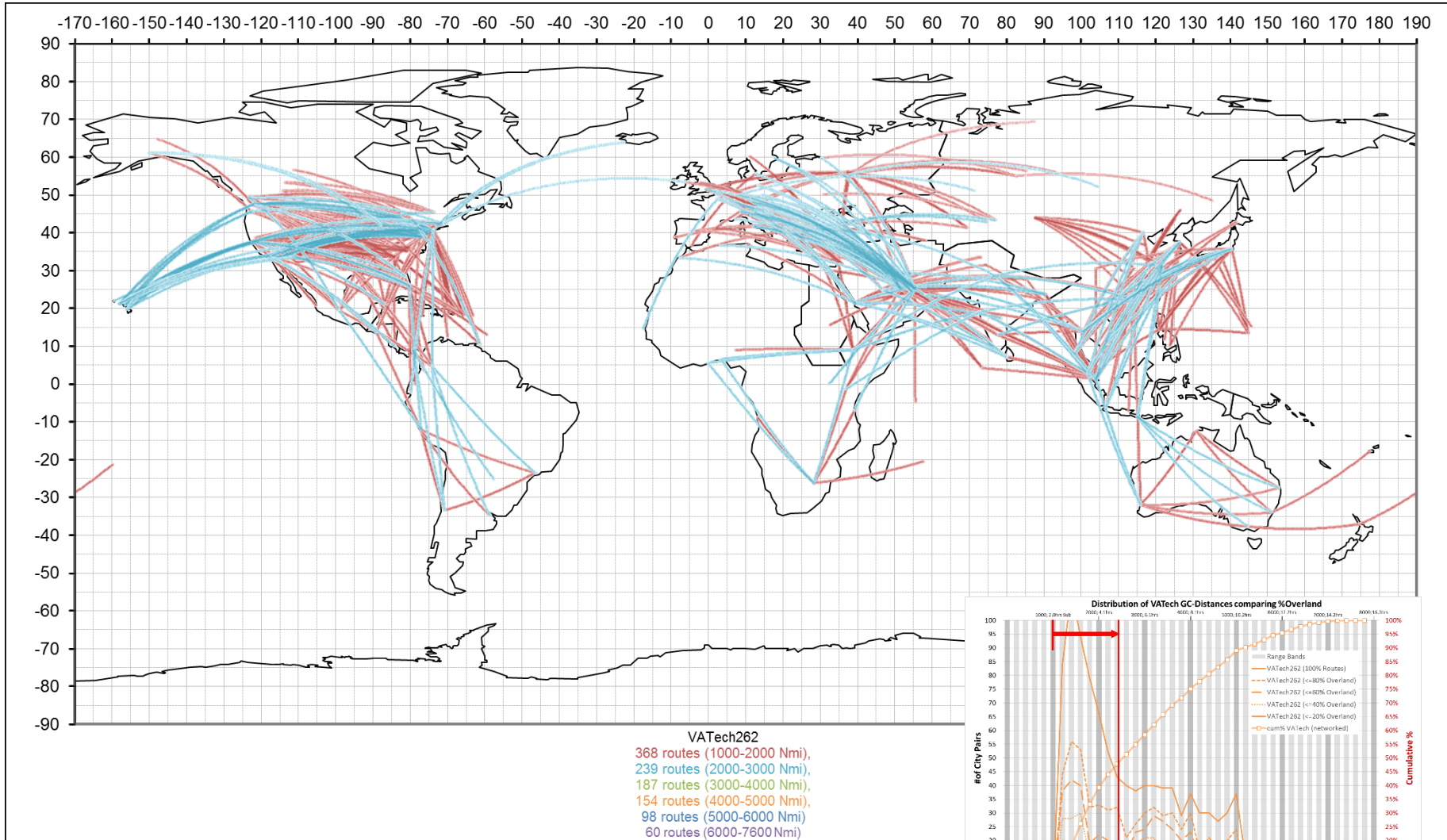

<2600 Nmi

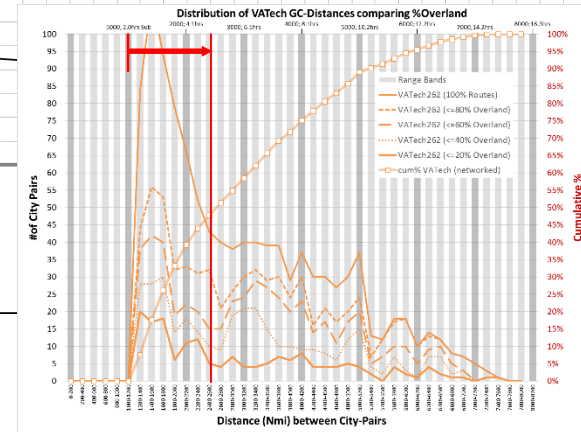

2600 < Range < 3800 Nmi

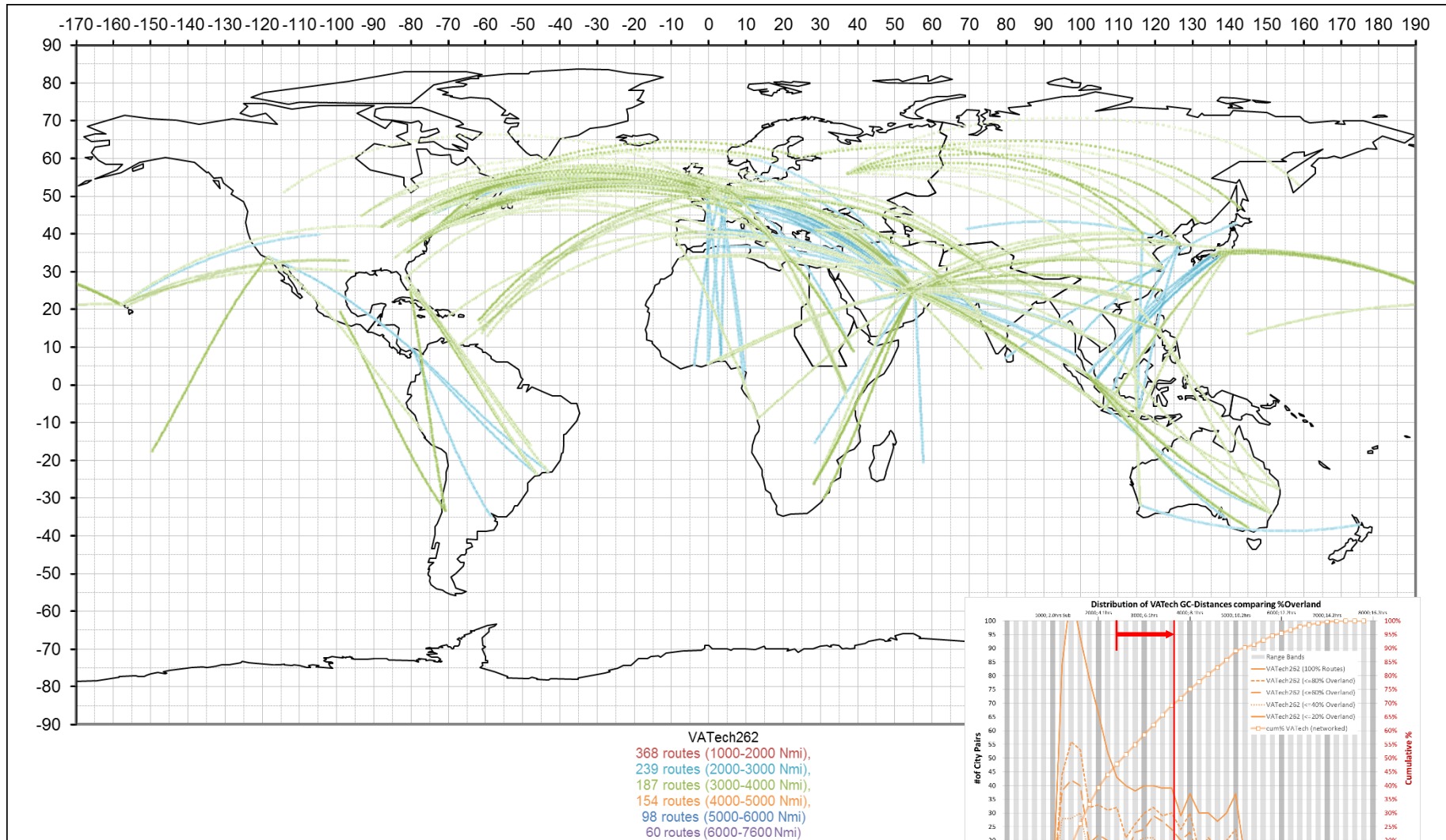

<3800 Nmi

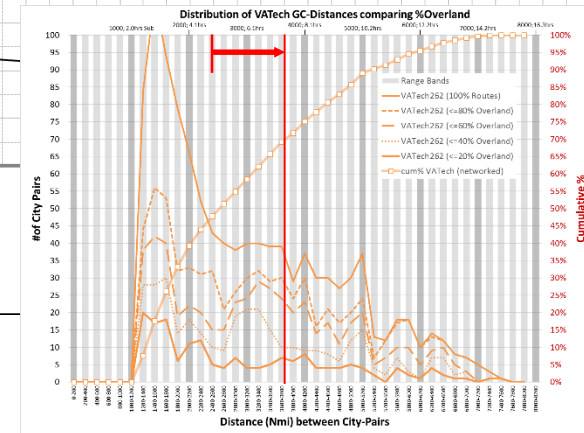

3800 < Range < 4800 Nmi

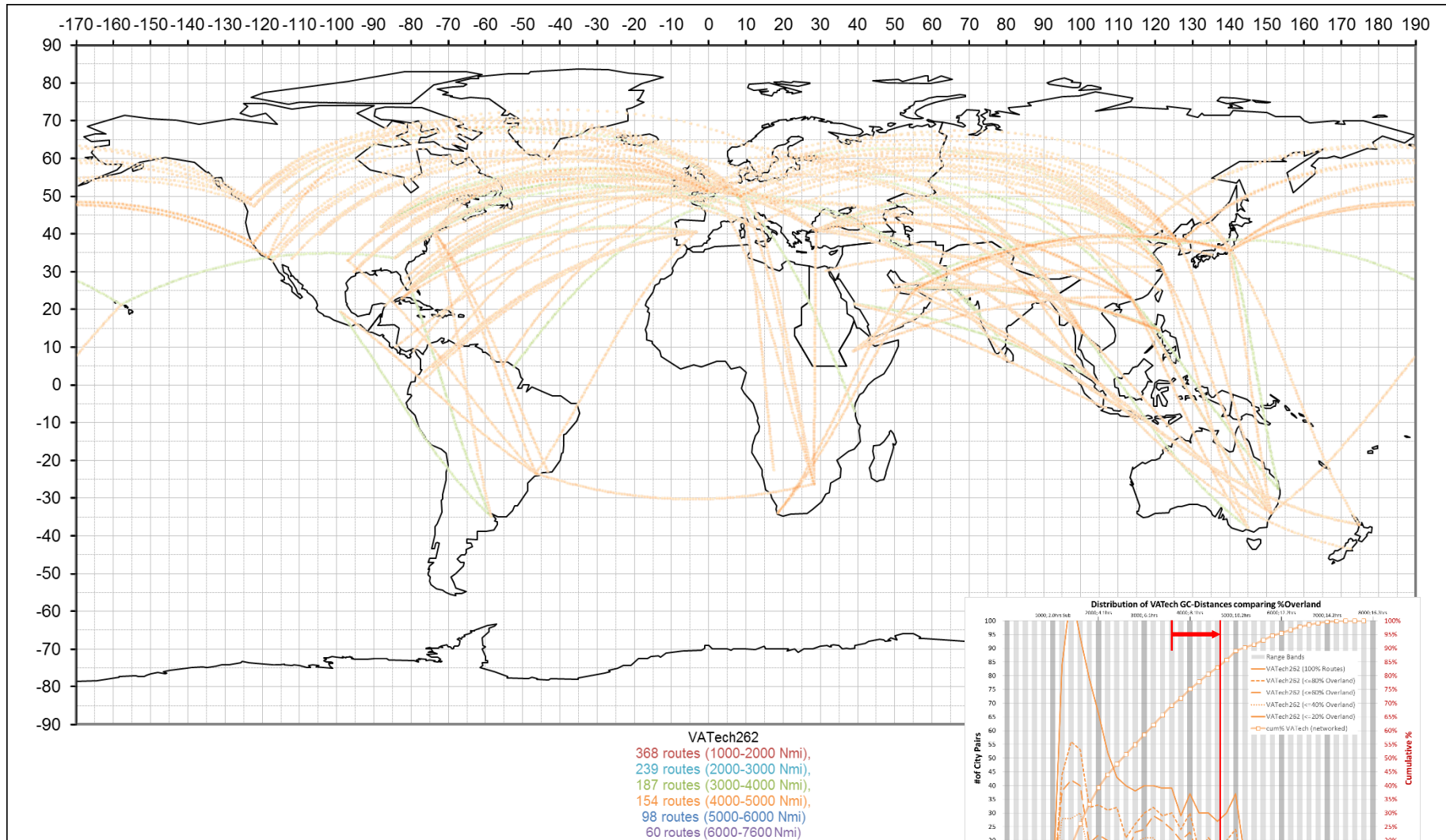

<4800 Nmi

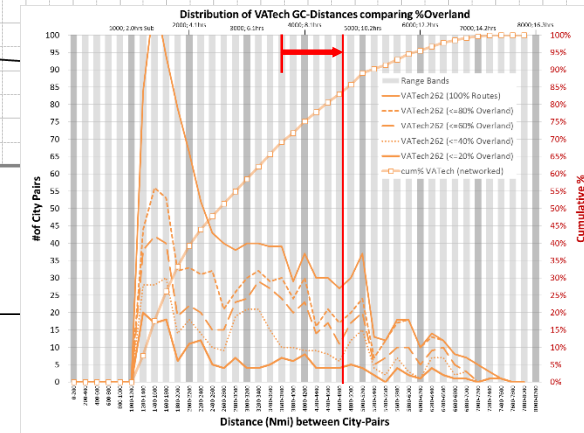

4800 < Range < 5400 Nmi

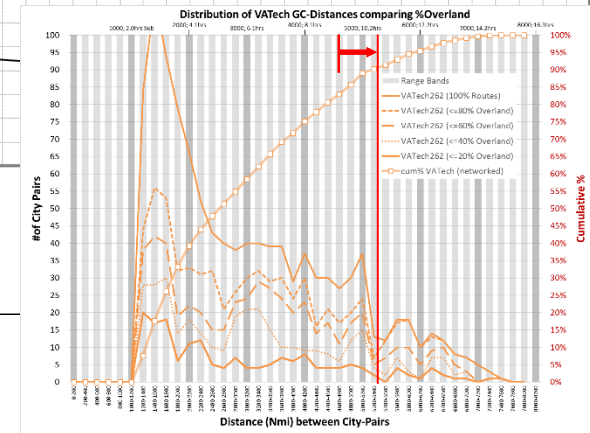
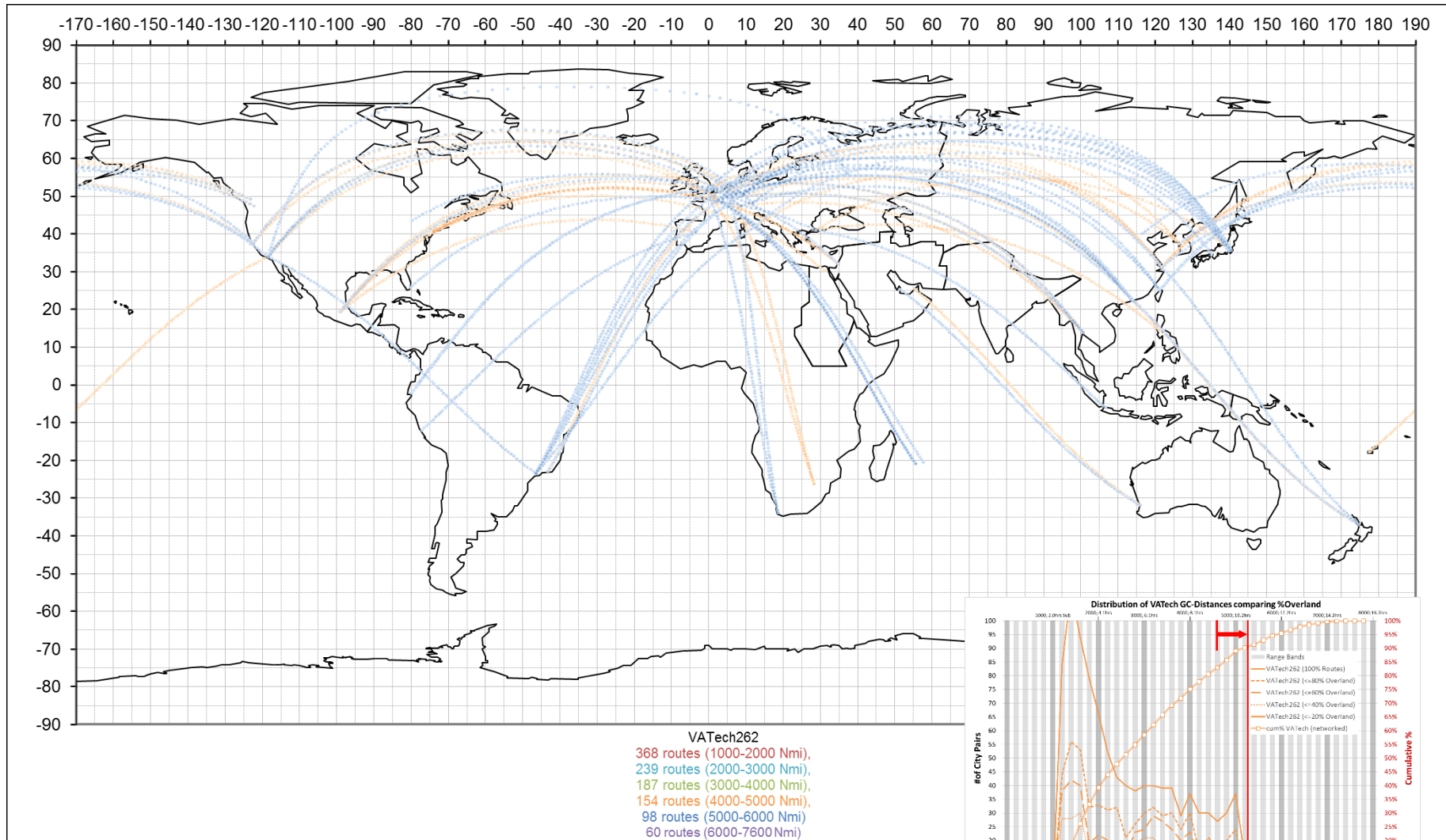

<5400 Nmi

Passenger Demand (based on Value Of Time) differs in Different Markets



Demand Analysis Steps:

- 1) Estimate aircraft lifecycle cost and minimum fare per pax mile.
- 2) Project future passengers / OD pairs
- 3) Filter out infeasible OD pairs
- 4) **Compute historic distribution of fares for each route**
- 5) Calculate time savings on each route
- 6) Adjust fare distribution based on VOT
- 7) Determine # of passengers willing to pay aircraft fare per pax mile
- 8) Case #1: 50% shift of remaining pax,
Case #2: 100% shift of remaining pax
- 9) Determine flights/aircraft needed to fulfill passenger demand.

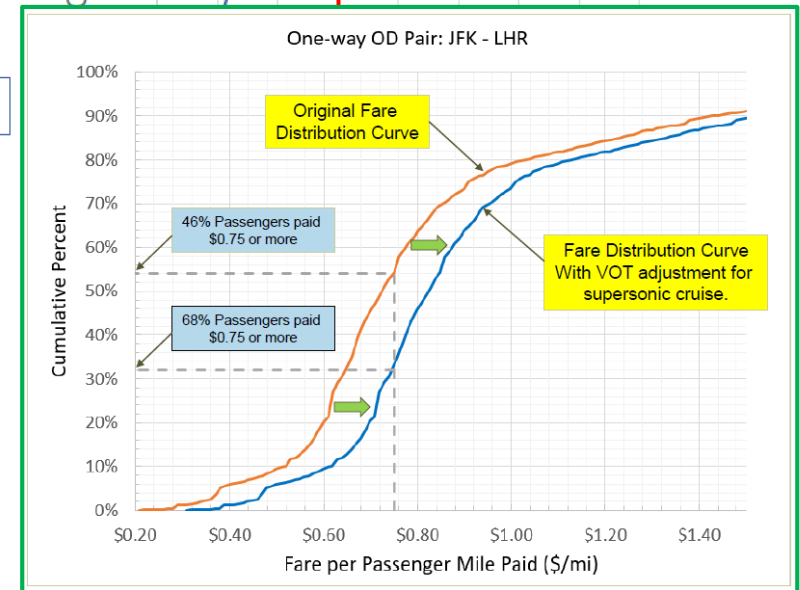
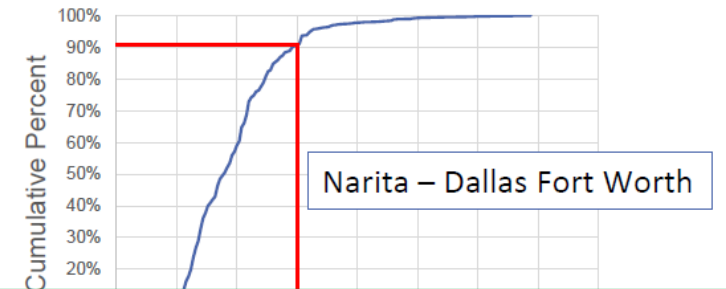
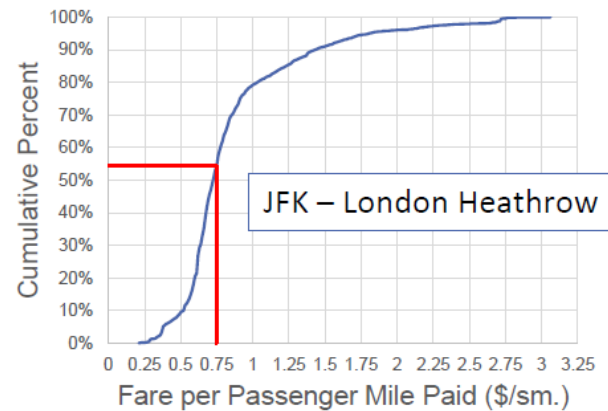
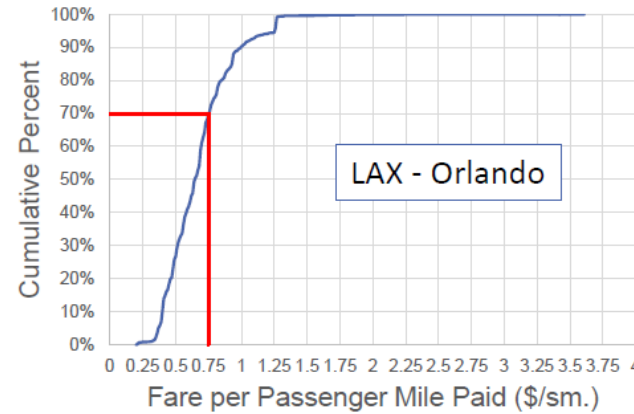

Minimum fare per passenger mile

	18 passenger	40 passenger	60 passenger
Low-boom	\$1.57	\$0.81	\$0.65
Non low-boom	\$1.50	\$0.75	\$0.61

Premium Class Willingness to Pay (Supersonic %capture read from top down on CDF)



Demand Analysis Steps:

- 1) Estimate aircraft lifecycle cost and minimum fare per pax mile.
- 2) Project future passengers / OD pairs
- 3) Filter out infeasible OD pairs
- 4) Compute historic distribution of fares for each route
- 5) Calculate time savings on each route
- 6) Adjust fare distribution based on VOT
- 7) **Determine # of passengers willing to pay aircraft fare per pax mile**
- 8) Case #1: 50% shift of remaining pax,
Case #2: 100% shift of remaining pax
- 9) Determine flights/aircraft needed to fulfill passenger demand.

National Aeronautics and Space Administration

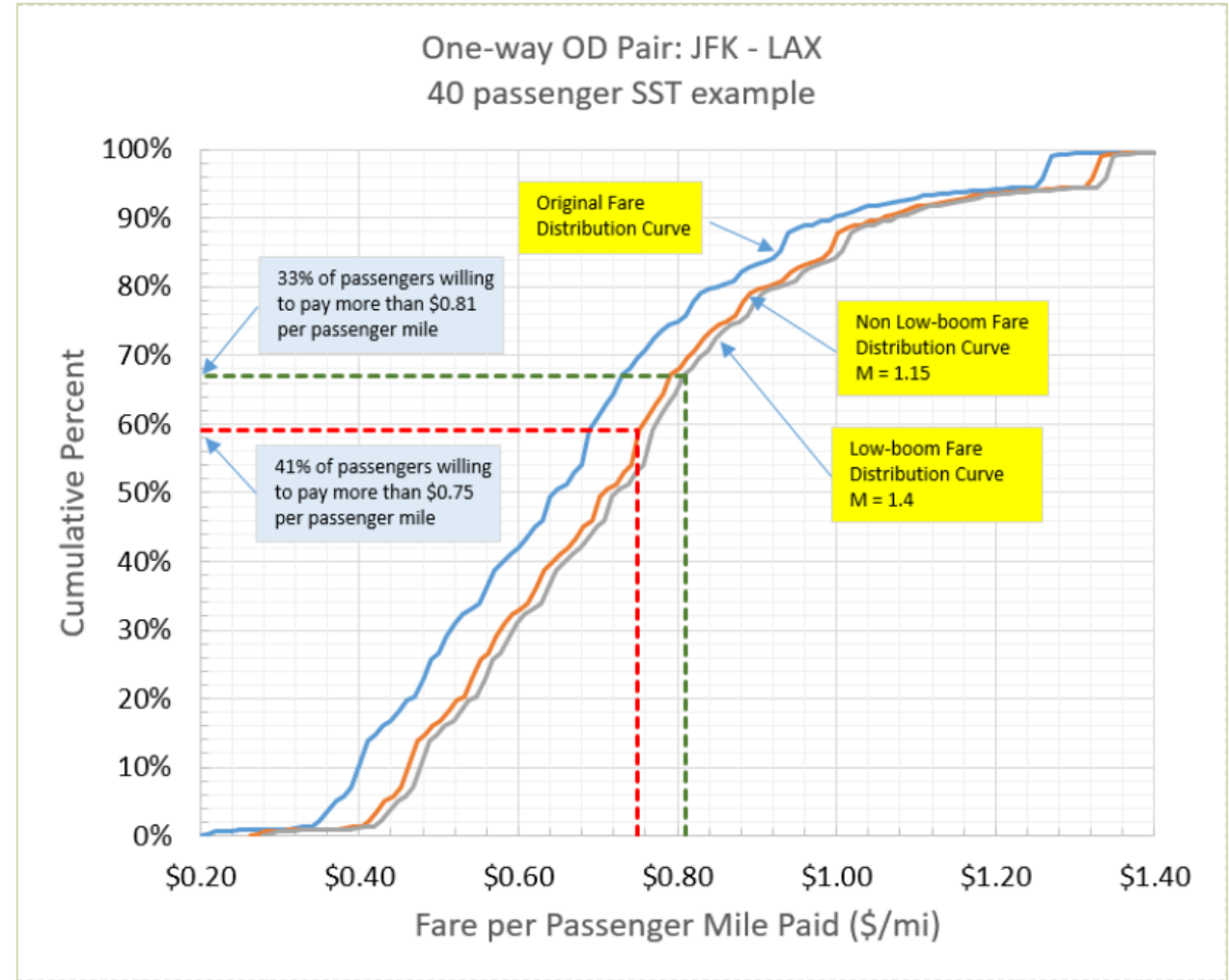

Global Supersonic Transport Demand Study

Barriers to Practical Supersonic Commercial Aircraft

Environmental Barriers

Sonic Boom

- Design for low noise sonic boom
- Understand Community Response

Landing/Take-Off Noise

- Certification noise levels not louder than subsonic aircraft at appropriate airports

Landing/Take-Off and High Altitude Emissions

- Certification emissions levels
- Acceptable emissions at supersonic cruise altitudes

Efficiency Barriers

Efficient Vehicles

- Efficient airframe and propulsion throughout flight envelope

Efficient Operations

- Airspace-Vehicle interaction for full utilization of high speed

Light Weight, Durable Vehicles

- Low airframe and propulsion weight in a slender flexible vehicle operating at supersonic cruise temperatures



Environmental Acceptability



Landing/Take-Off Noise

- Integrated solutions including inlet and fan noise, innovative concepts, tools & techniques, and experimental validation
- Adverse impact to local property values
- Reduced O-D pairs due to local stringencies

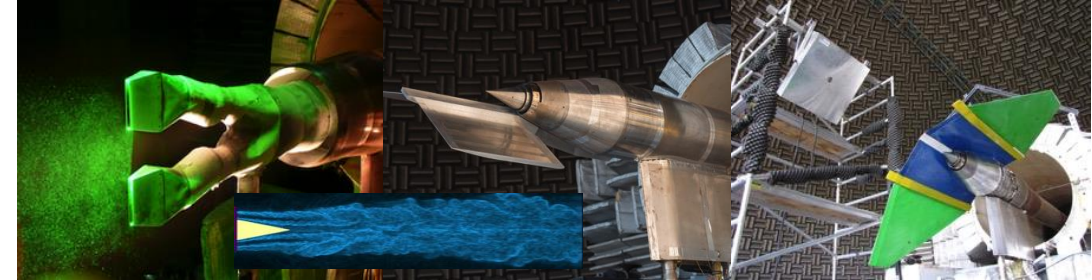

Landing/Take-Off & High Altitude Emissions

- Engaging atmospheric science community to improve global high altitude emission models and study the impacts from future supersonic fleet scenarios
- Next-gen CMC combustor liner technologies to improve existing Rich-burn combustors while enabling future Lean-burn & staged injection with sustainable alternative fuels
- Adverse impacts to local & global environment are lasting
- Reduced O-D pairs due to local stringencies

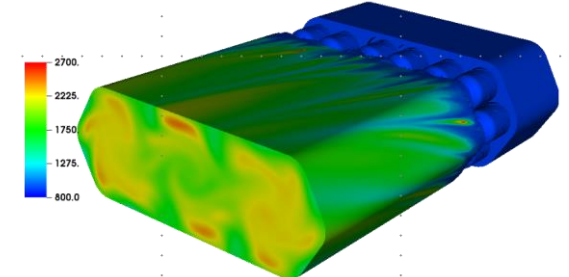
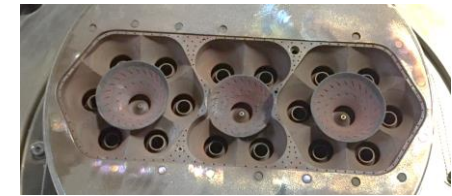

Support of FAA/ICAO studying operations & regulatory impacts

- Supersonic Technology Concept Aeroplane (STCA), Market, Noise, Emissions trades



55t STCA Business Jet Concept

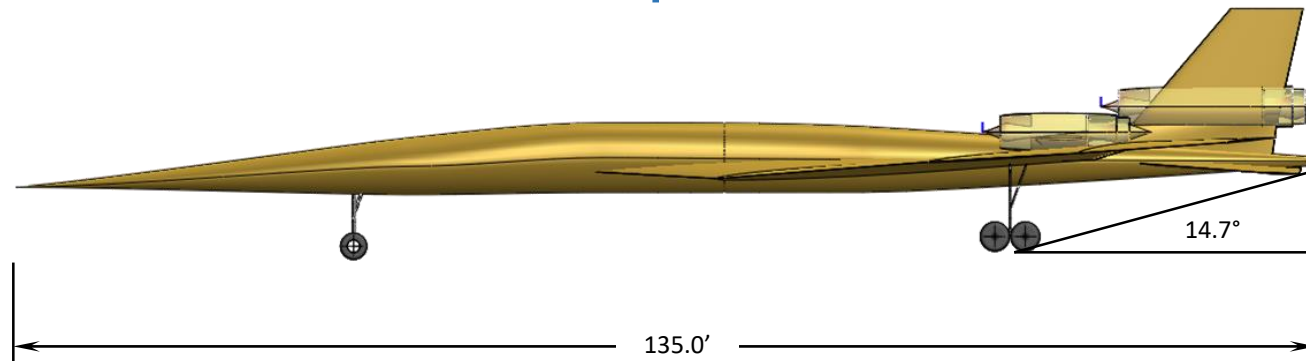

- Max gross weight 55t (121klb)
- Passengers 8
- Cruise Mach 1.4
- Engines (x3) CFM56-derived
- Length 135ft
- Span 67.3ft
- Reference area 1619ft²
- Aspect ratio 2.7
- Taper ratio 0.09
- Wing loading 74psf
- Wing fuel ~24klb
- Fuselage fuel ~36klb
- Fuel fraction ~0.50

Differs from 2018 STCA;
improvements with help from
NASA Langley

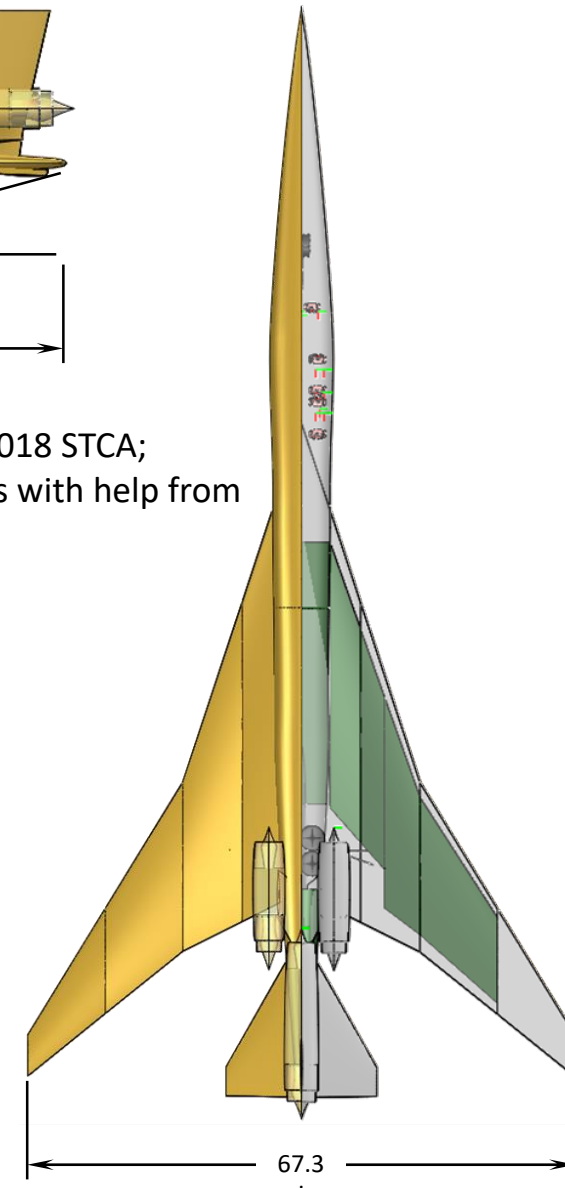



Supersonic Derivative Engine

- Analytical redesign of CFM COTS CFM56-7B27 low-pressure spool
- CFM56 core began as the GE F101-102, for the B-1A supersonic aircraft;
- Numerical Propulsion System Simulation (NPSS) software
- Model design changes:
 - High spool components held constant
 - Translating centerbody inlet
 - Booster removed
 - Revolutionary Turbine Accelerator fan
 - GE57 single-stage fan; PR 2.2, η 0.87
 - Perhaps representative of what might be used by a major engine maker in a supersonic refan application
 - Redesigned low turbine
 - Forced lobed mixer
 - Axisymmetric, single-stream, variable-geometry, convergent-divergent plug nozzle
- *Predict thrust & fuel flow across flight envelope; use in performance analysis*

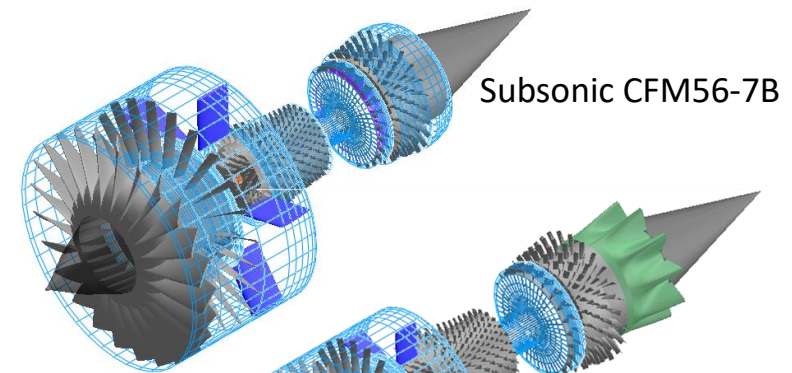
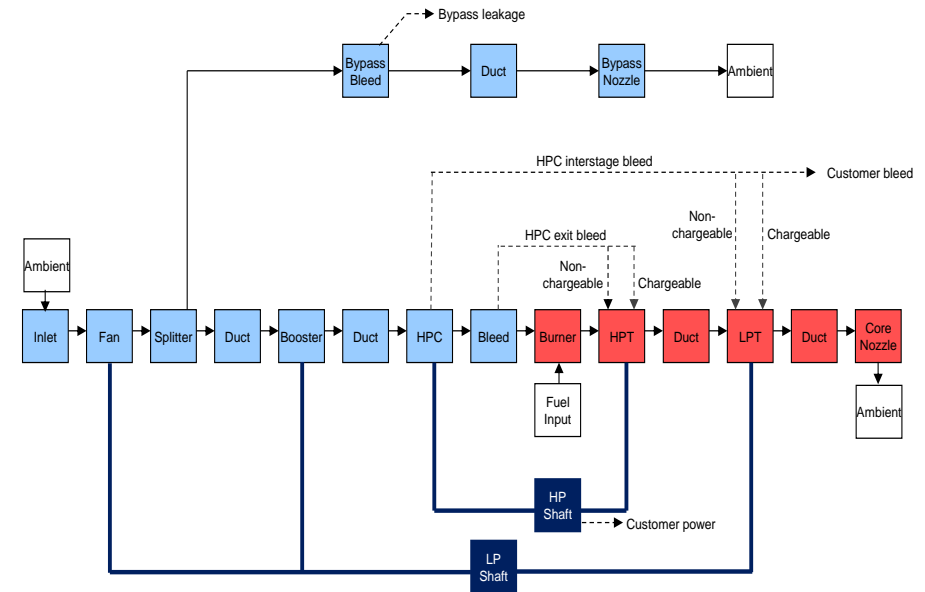

Subsonic CFM56-7B

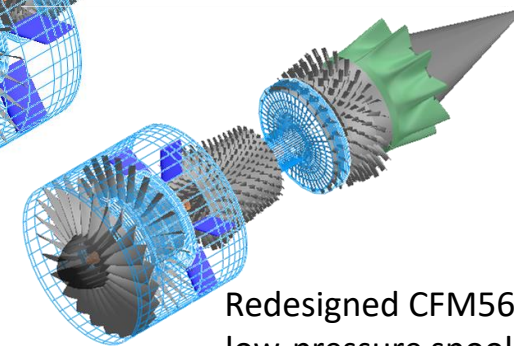

Redesigned CFM56-7B low-pressure spool for supersonic application



Noise Type-Certification Process

Effective Perceived Noise Level:

- Sources at flight conditions
- Propagation and ground effects
- Noy-weighted summation
- Tone content penalties

Result:

Ground observer noise vs. time history

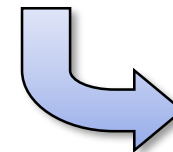
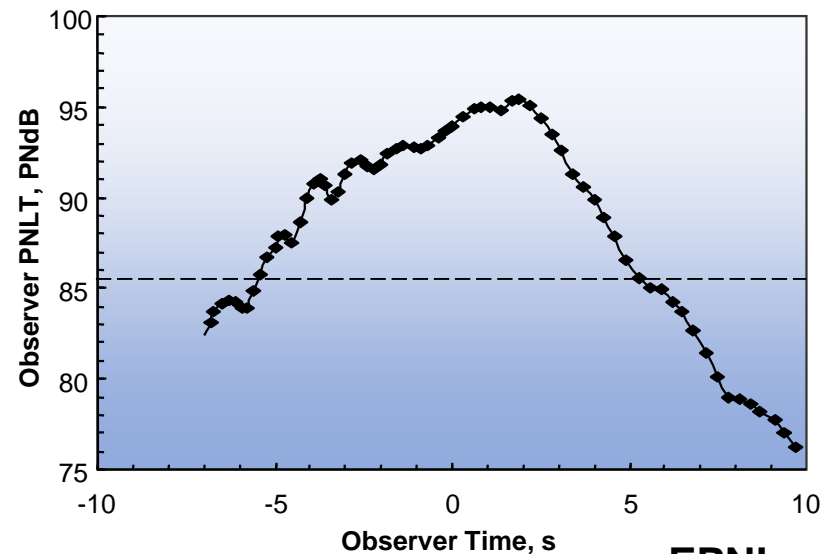
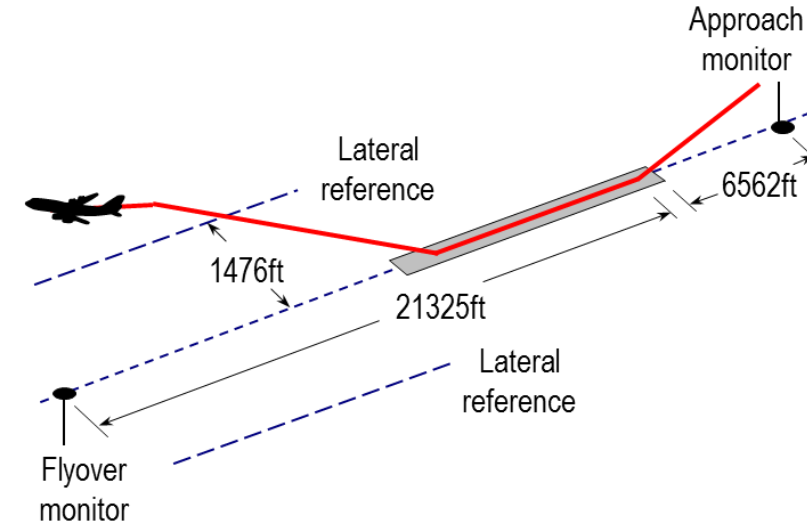
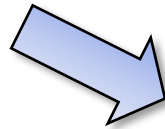

EPNLs

- Lateral
- Flyover
- Approach

International Standards and Recommended Practices – Environmental Protection, Annex 16 to the Convention on International Civil Aviation, Vol. I

U.S. Code of Federal Regulations, Title 14, Chapter I, Part 36



Profiles for Noise Certification: Selected LTO Flight Conditions

Point	DFBR, ft	Altitude, ft	Speed, kcas	Thrust, lb
1	0	0	0	16,617
2	6560	35	199	13,811
3	7375	35	210	13,720
4	10,062	400	212	12,207
5	12,325	1000	199	13,437
6	13,550	1000	212	12,001
7	17,000	1916	199	13,090
8	17,000	1616	212	11,791
9	18,037	2093	199	8844
10	18,104	1785	212	7531
11	21,325	2418	199	8762
12	21,325	2054	212	7474
13*	-7518	394	165	5328

*Approach point (glide slope is 3 degrees)

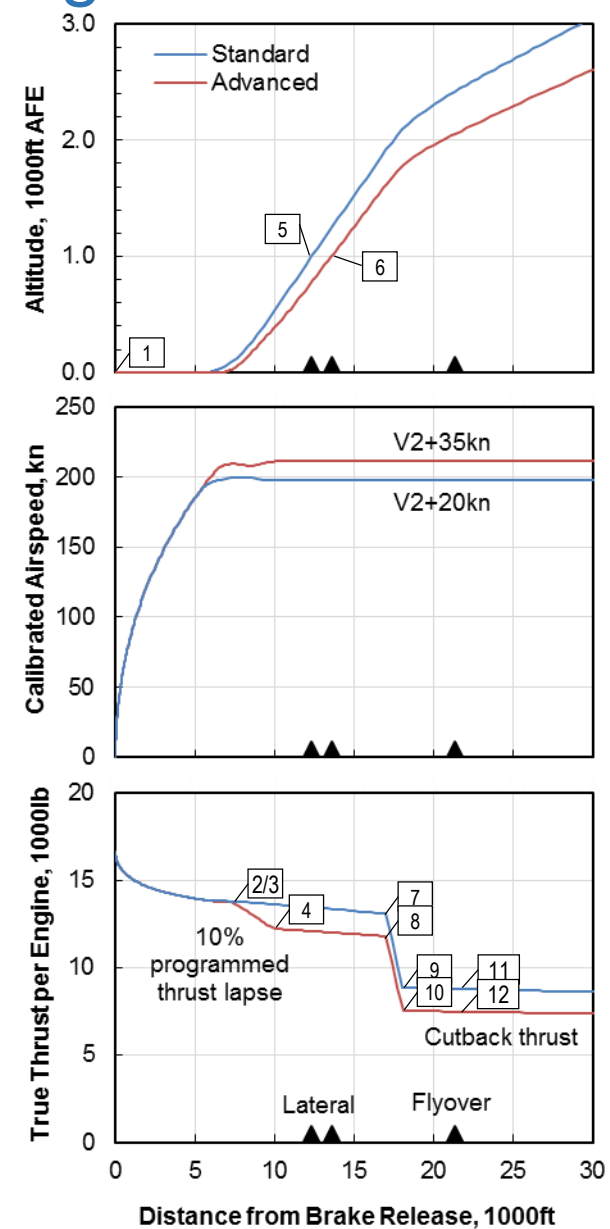

55t STCA EPNL Predictions, June 2019

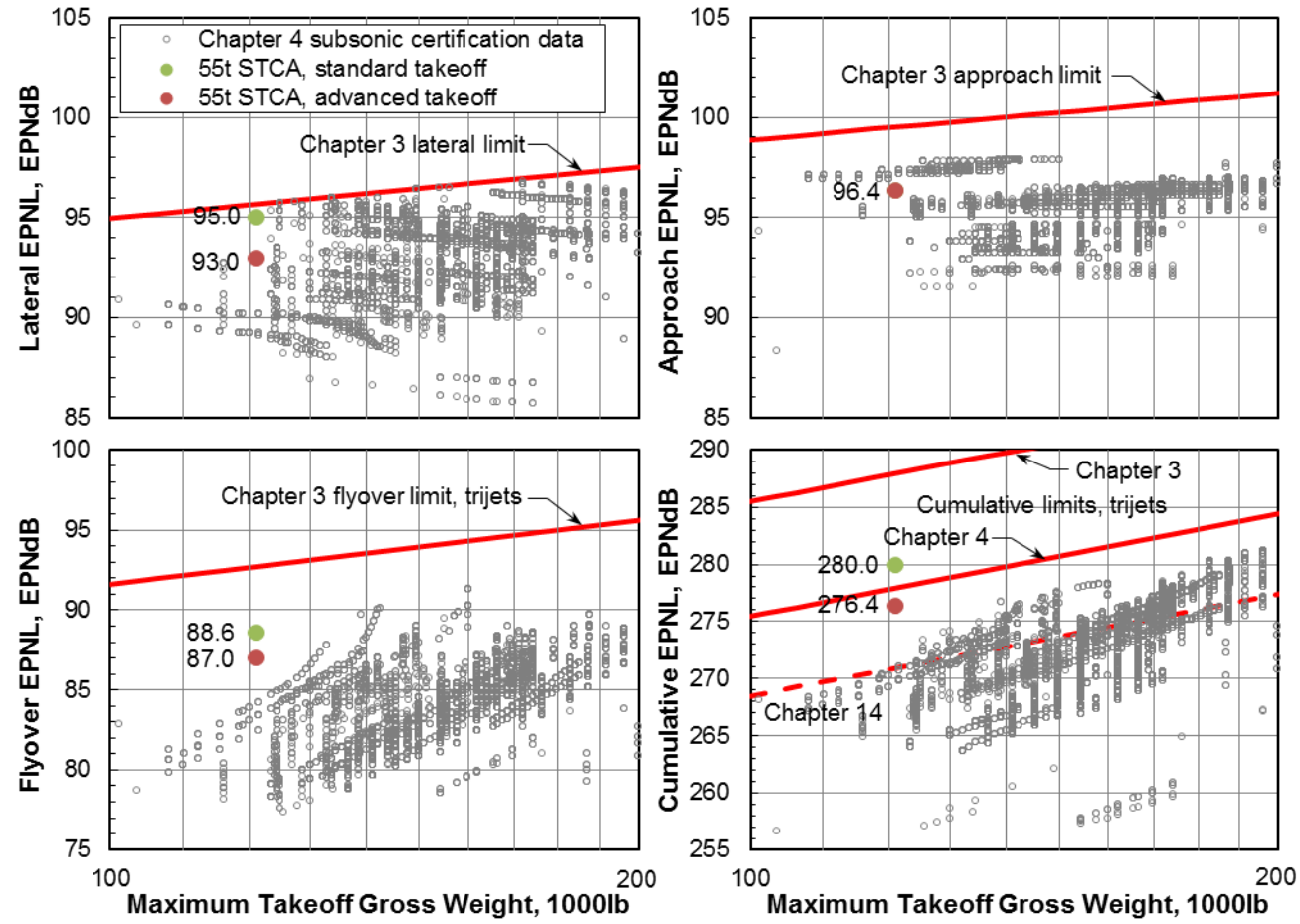

Advanced takeoff uses (1) V2+35kn climbout and (2) 10% programmed thrust lapse. 1.6 EPNdB cumulative margin to Chapter 4.

EPNL Sensitivities Due to Uncertainties

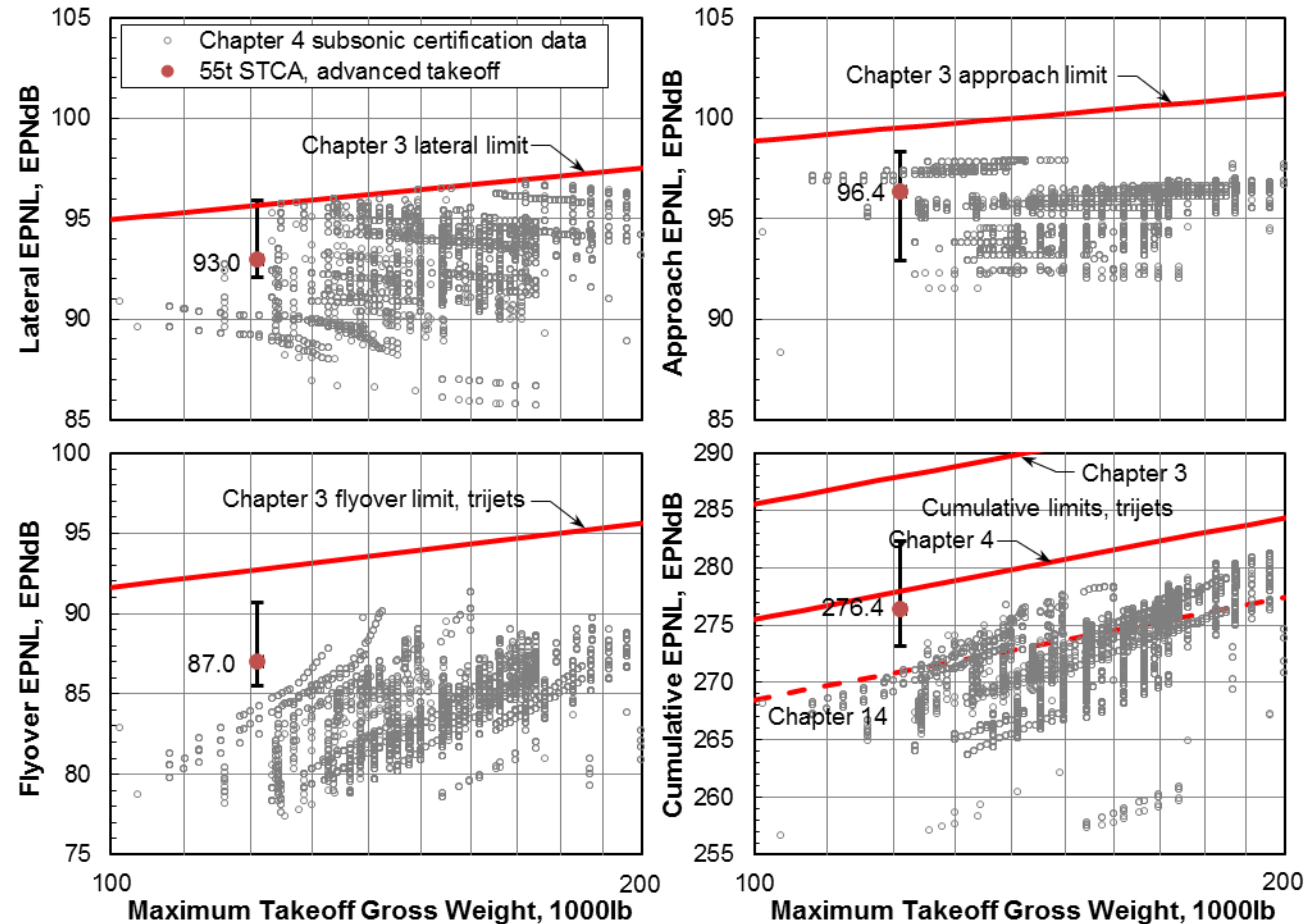

Sensitivity bars represent two standard deviations of Monte Carlo experiment histograms (i.e., 95% of samples fall in band)

Source Noise and Operational Uncertainties



- Airframe noise source uncertainties
 - Effects of higher TO speed on constituent sources (landing gear, flaps/slats, etc)
 - Shielding for supersonic geometries
- Propulsion noise source uncertainties
 - High pressure fan, ~low/modest bypass ratio
 - High speed jet and shock-cell noise
 - Inlet geometries & suppression effects, liners, aux door noise radiation
 - Nozzle geometries (e.g. non-axi exit areas, plug nozzles, etc.)
- Operational uncertainties
 - Ground and refraction-scattering effects
 - Accurate predictions of lateral system noise are critical, especially for supersonic transports exploiting lateral attenuation using programmed thrust lapse procedures

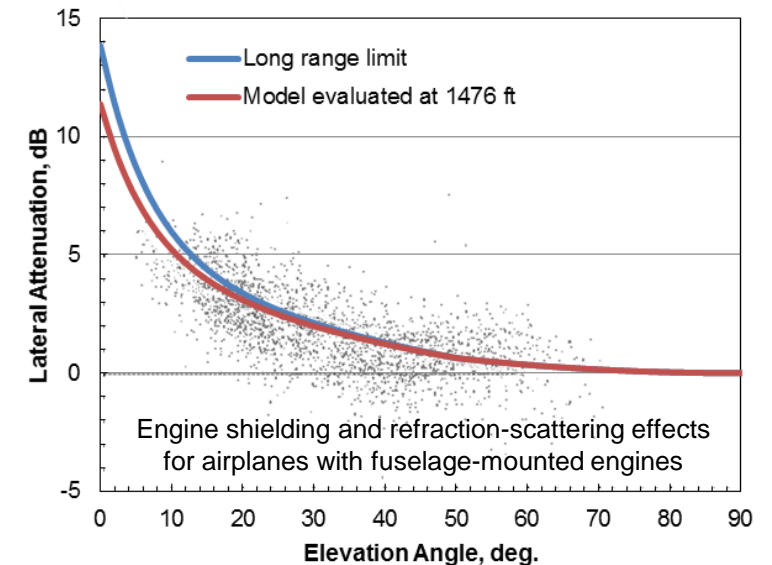
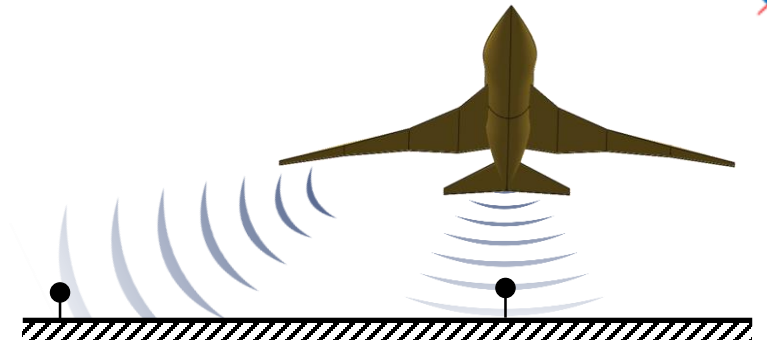

*Chien, C. F.; and Soroka, W. W.: "Sound Propagation Along an Impedance Plane," J. Sound & Vib., vol. 43, no. 1, Nov. 8, 1975, pp. 9-20
**Society of Automotive Engineers: "Method for Predicting Lateral Attenuation of Airplane Noise," Aerospace Information Report 5662, April, 2006

55t STCA Engine Variants

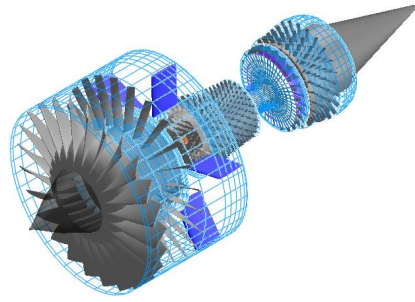

NASA CFM56-7B27 model:
Commercial subsonic off-the-shelf separate flow turbofan

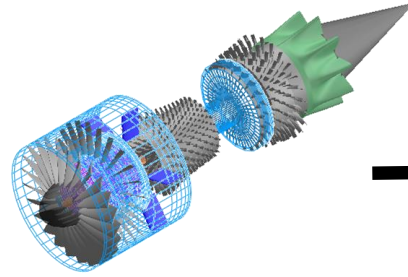

NASA 55t STCA engine (2017):
High-TRL, mixed flow turbofan with redesigned low-pressure spool for supersonic application

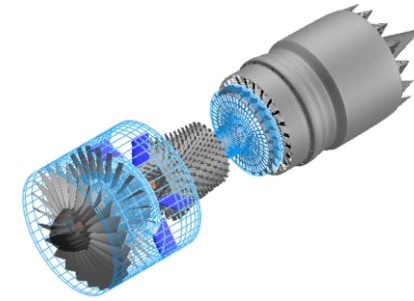

Variant engine (2018):
Nozzle chevron study

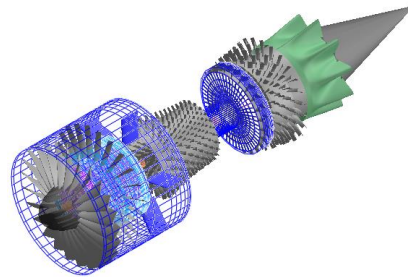

Variant engine (2018):
Excursion in bypass ratio.
High-TRL, mixed flow turbofan with lower fan pressure ratio and higher bypass ratio



55t STCA: Takeoff Profiles of Engine Variants

- Advanced takeoff procedures held constant
- *Baseline vs. higher bypass engine:*
Thrust lapses differently for higher BPR variant
- *Baseline vs. chevron-equipped engine:*
Thrust penalty due to chevrons

- But departure profiles are nearly unchanged

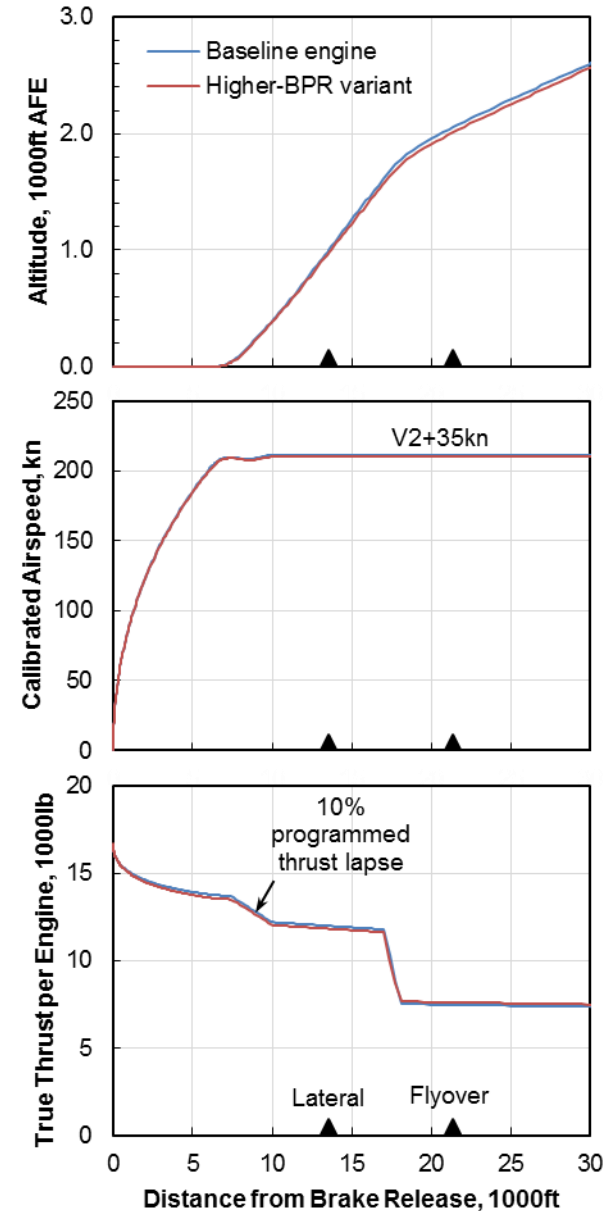

55t STCA: Higher Bypass Engine Variant

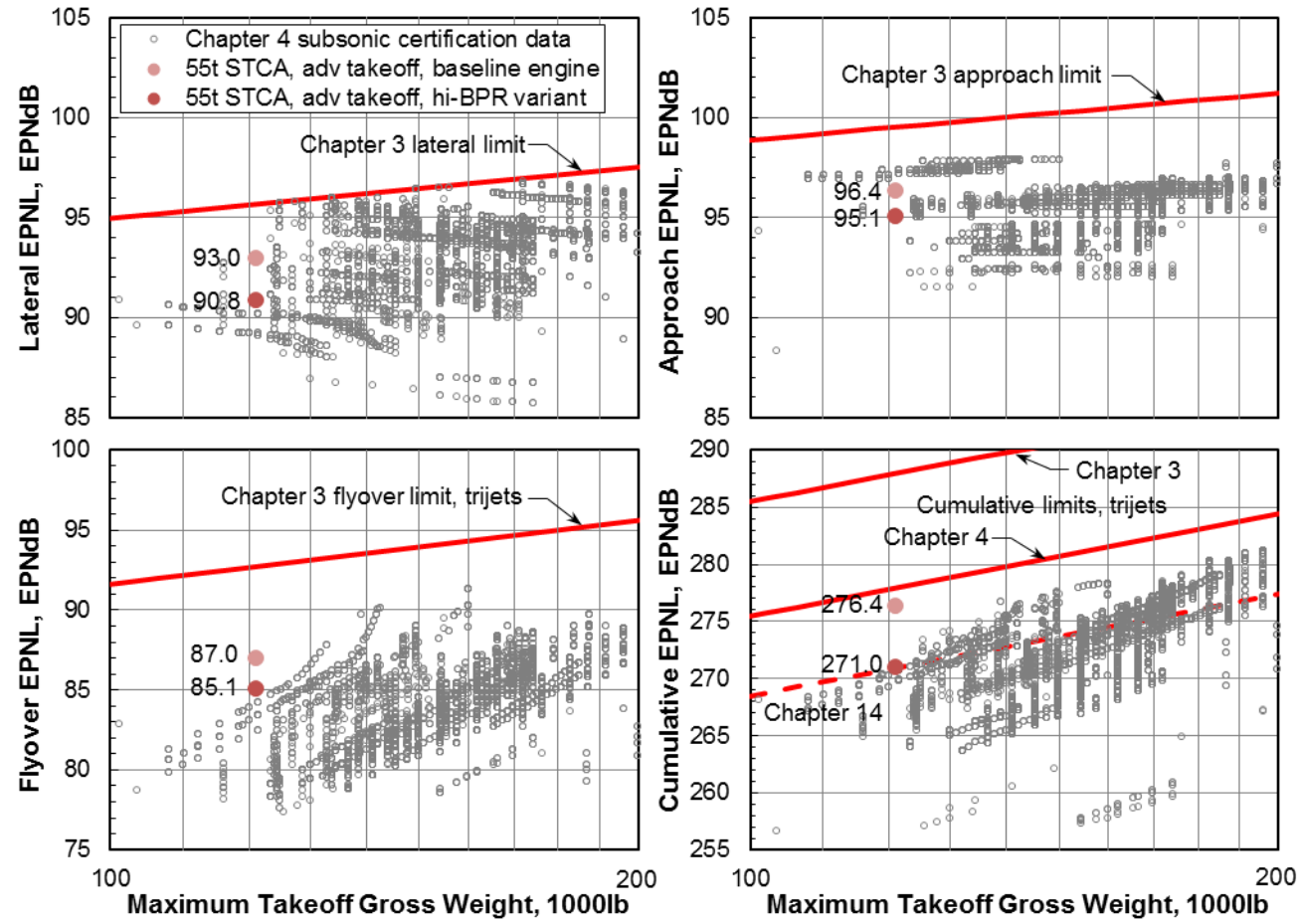

Cumulative EPNL benefit of higher bypass cycle: 5.3 EPNdB (4.1% range penalty)

55t STCA: Chevron Engine Variant

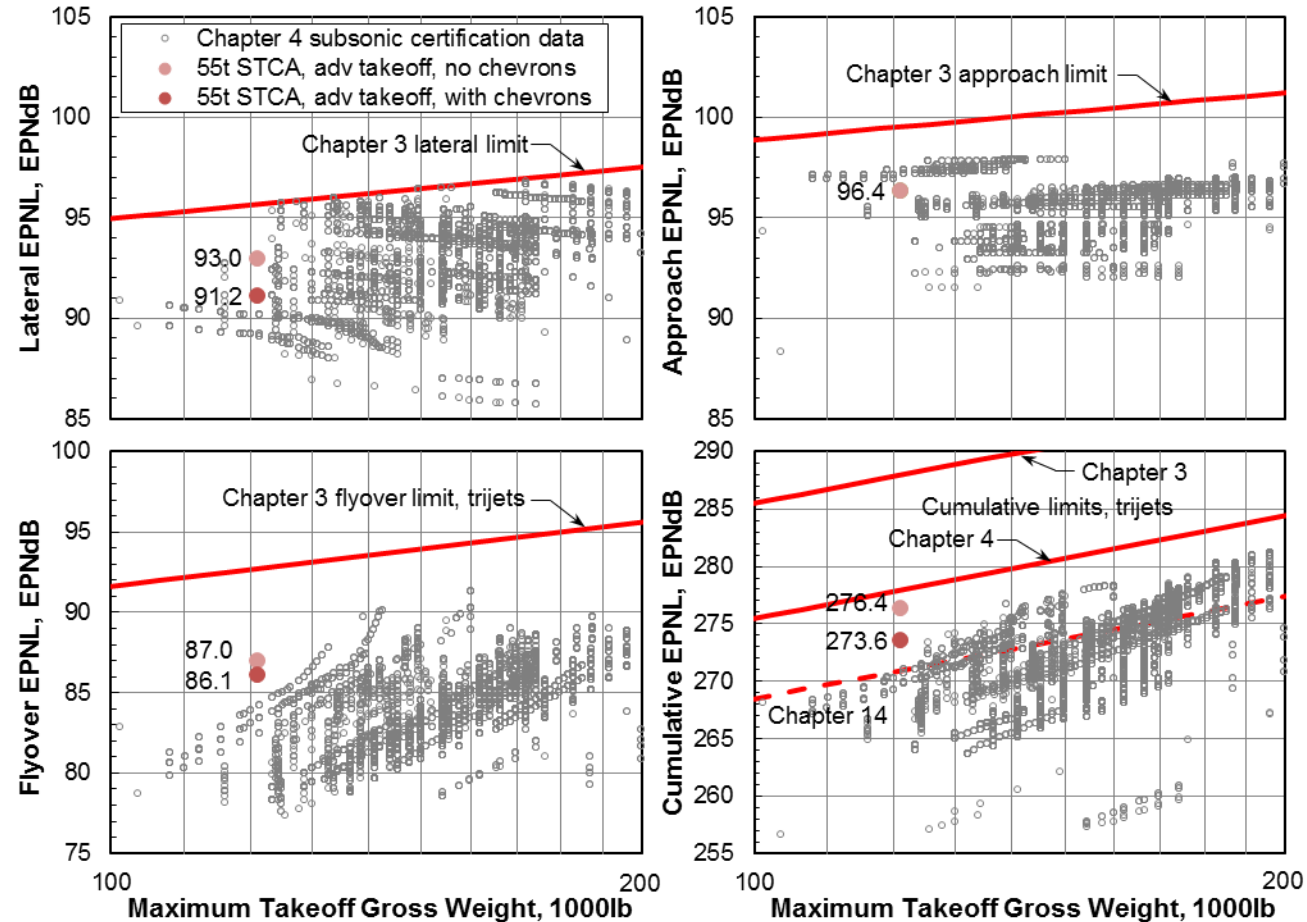

Cumulative EPNL benefit of chevrons: 2.7 EPNdB (2.8% range penalty)

Summary



- Sufficient premium seat traffic exists at Mach~1.6 to support commercial production rates
 - Aircraft capacity appears to favor $\ll 100$ passengers (to maintain load factors & reasonable production rates)
 - Most O-D pair routes have substantial overland fractions without GC diversions
- Environmental impacts must be addressed for certification, regardless of cruise mission
 - LTO noise is more economically impacting
 - LTO & cruise emissions are more lasting; limiting cruise altitudes and speed to achieve acceptable levels
- Studies indicate affordable noise reductions are ~small for acceptable range penalties (fuel burn), and procedural choices have strong influence on both performance and noise
 - Operational procedures (PLR, high TO speeds, etc.)
 - Enhanced jet/ambient mixing (Chevrons, etc.)
 - Uncertainty reductions for supersonic geometries needed, otherwise large noise margins
- Longer mission ranges from higher cruise efficiency will require more robust acoustic technology investment
 - Suppressor nozzles
 - Multi-stream engine/nozzle systems