



# **Collaborative Forum 3.1: Suit Sizing for Optimal Fit**

## **EVA Technology Workshop 2020**

**February 20<sup>th</sup>, 2020**

**Moderator: Elizabeth Benson (KBR)**

**Panelists: Richard Rhodes (NASA), Han Kim (Leidos), Leia Stirling (University of Michigan)**

# SESSION AGENDA



- **Session Objectives (5 min)**
- **Introduction of Panel (20 min)**
  - Richard Rhodes (*NASA JSC*)
  - Han Kim (*NASA JSC*)
  - Rachel Vitali (*University of Michigan*)
- **Questions and Discussion (1 hr)**



# SESSION OBJECTIVES



- **Encourage open communication between NASA and the greater EVA community, regarding the complex topic of space suit sizing and fit assessment**
  - Recent advances in suit sizing and fit assessment tools
  - Current challenges in suit sizing and fit assessment
  - The potential for unique sizing and fit challenges on the lunar surface

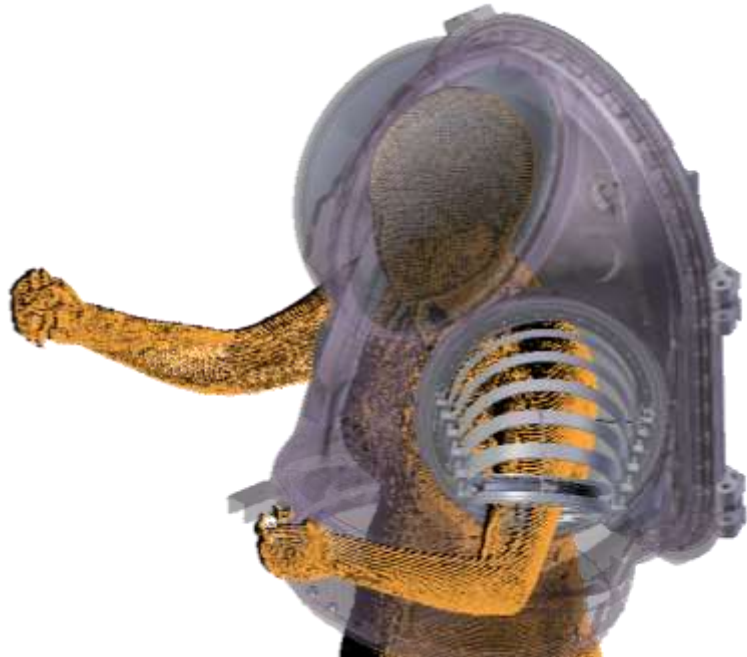

*Virtual fit checking of hardware*

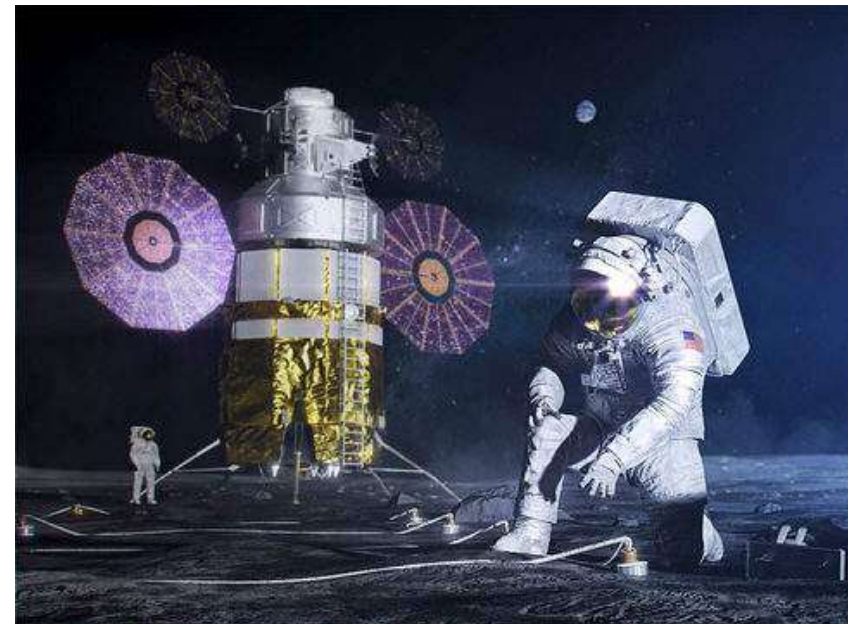

*What sizing and fit challenges are posed by lunar surface operations in the suit?*

# Panelist – Richard Rhodes



Richard.Rhodes@NASA.gov



# Collaborative Forum 3.1: Suit Sizing for Optimal Fit

## EVA Technology Workshop 2020

February 20, 2020

Han Kim (Leidos)

# Historical Suit Fit Check Methods

- Shuttle EMU: Linear measurements were compared between the body and suit
- Z-2: A limited number of 3-D body scans were overlaid to check the overlap the suit CAD
- Z-2 & Z-2.5: Increased number of body scans to assess “worst-case” fit testing (“boundary manikins”)

Linear Measurement Based

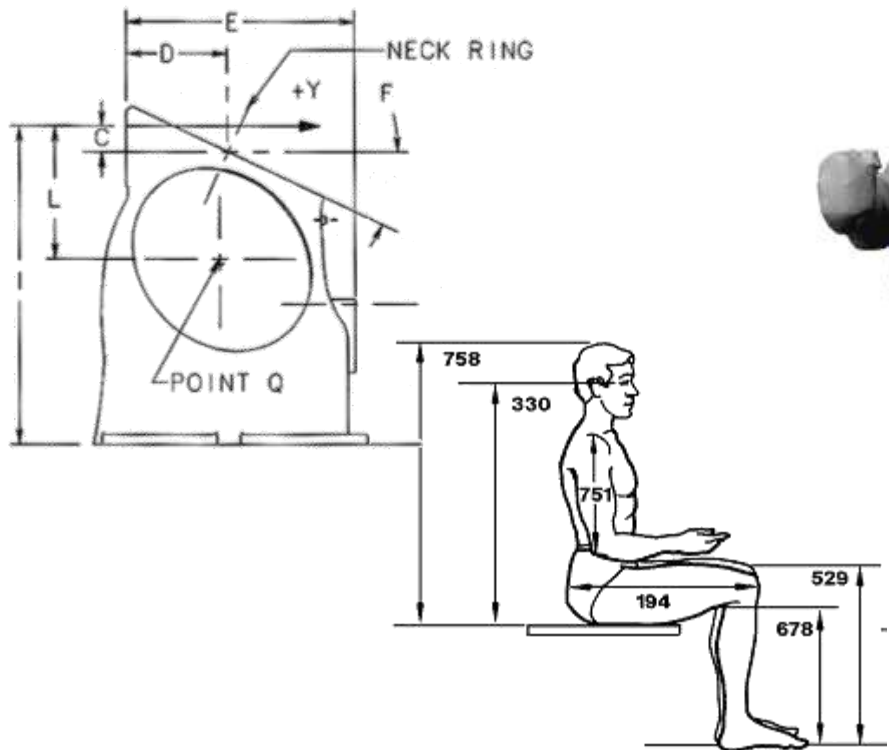

3-D Scan & CAD Fit Check

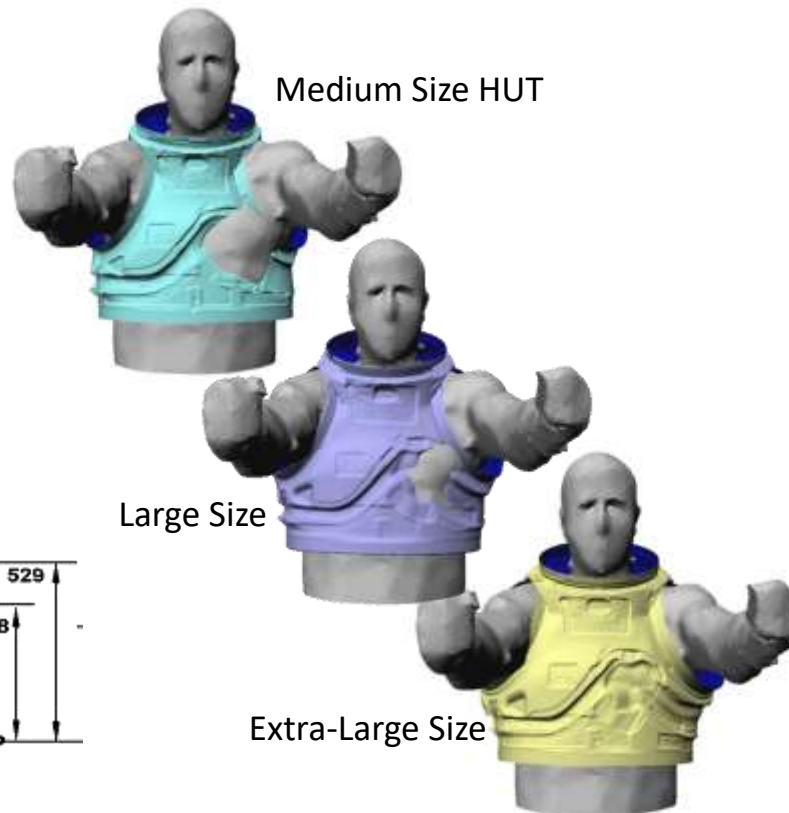

Boundary Manikin Tests

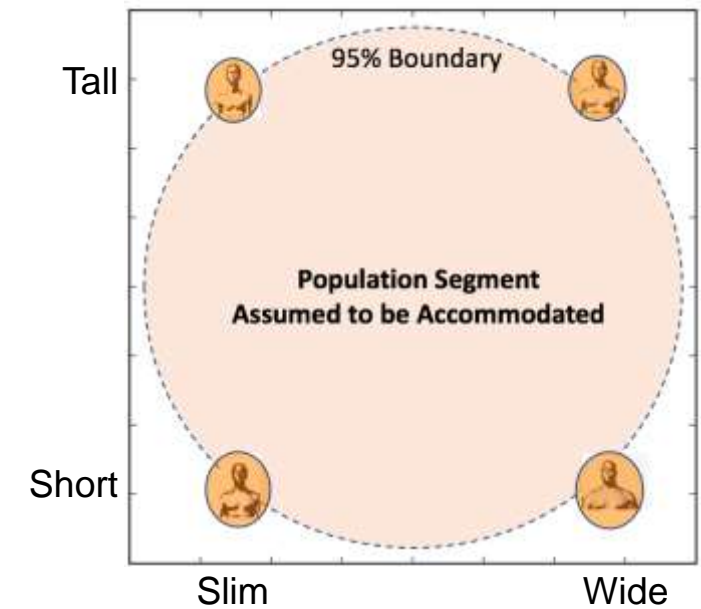

# New Method: Large-Scale Testing for Virtual Suit Fit

- Overlay the 3-D body scans with the CAD model of the suit
- Estimate the suit-to-body contact and overlap
- Build a statistical classifier to predict the fit probability as a function of the suit-to-body overlap

Virtual Suit-to-Body Contact and Overlap Estimation

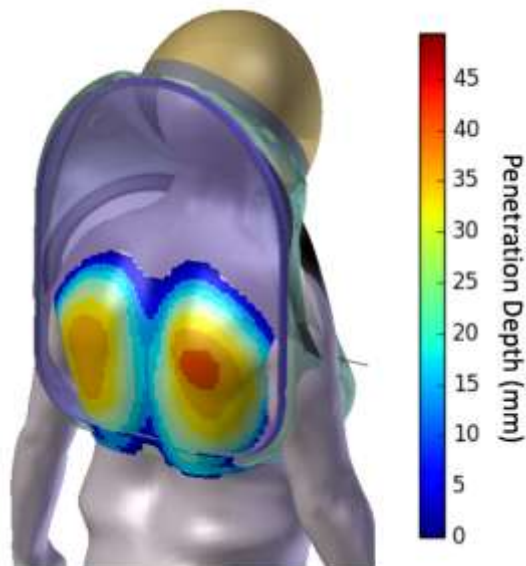

Suit-to-Body Overlap Score Calculation

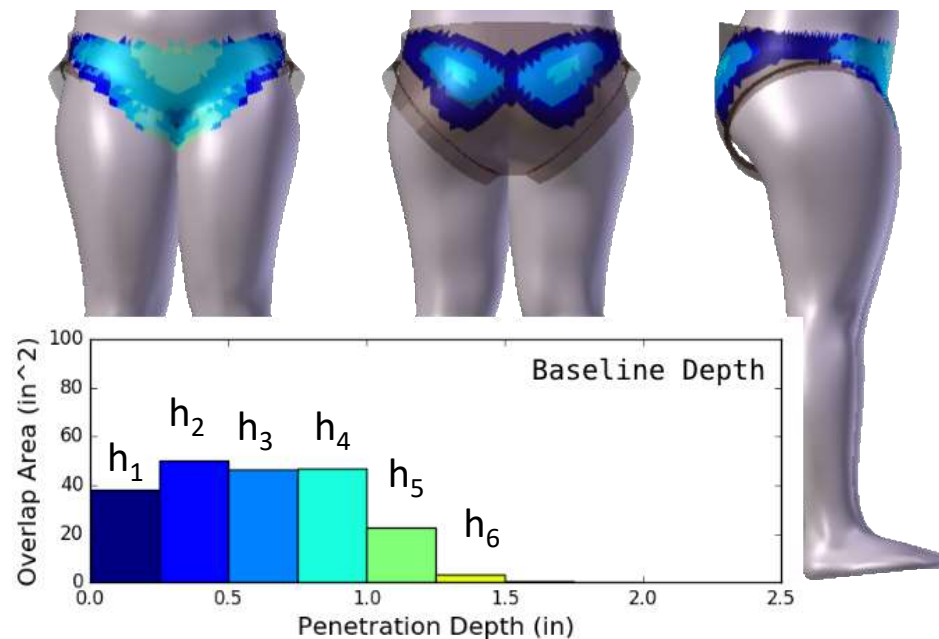

$$\text{Overlap Score} = w_1 \cdot h_1 + w_2 \cdot h_2 + \dots + w_n \cdot h_n$$

Machine Learning Classifier

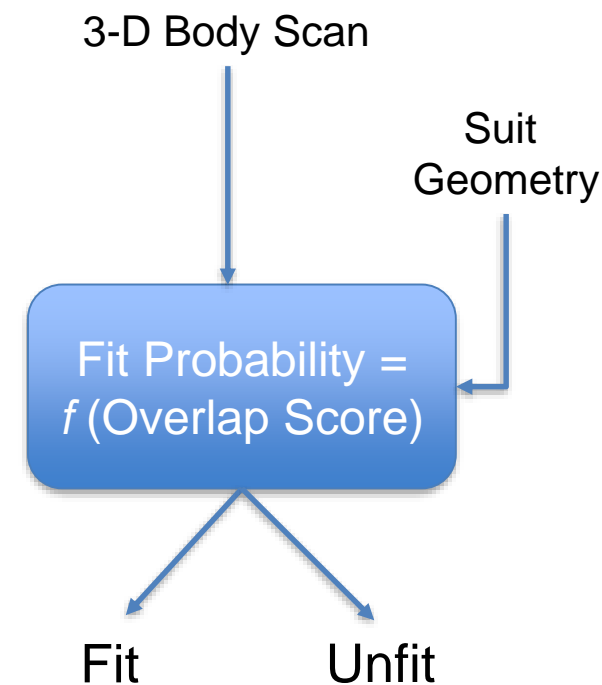

# Test Subject Selection and Iterative Classifier Training



- Sort the potential subjects by overlap score and visually inspect the overlap charts
- From overlap charts, subjects “obviously likely” to fit (or unfit) were excluded from physical testing
- Physical fit tests performed with borderline fit subjects
- Iteratively update the fit classifier by physical fit test outcome

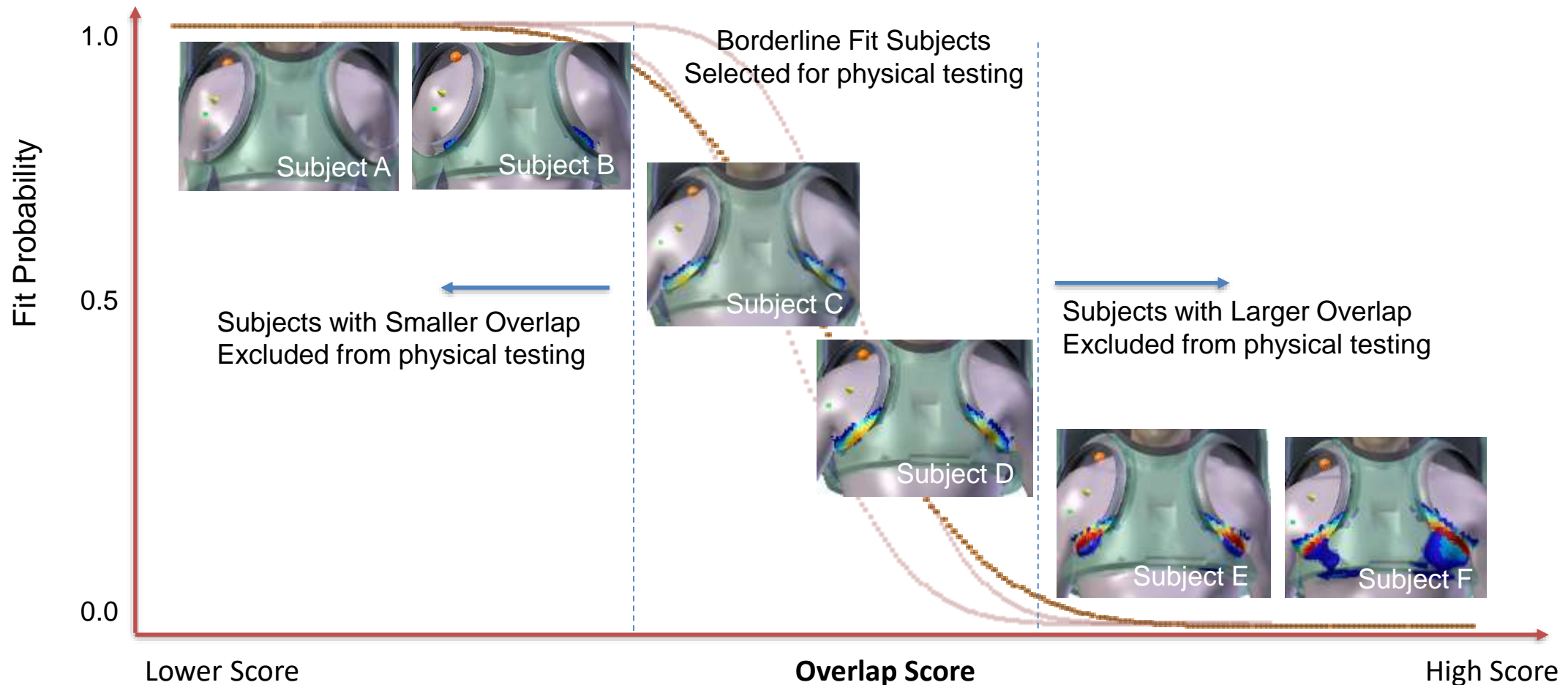



# Classifier to Estimate Crew Population Accommodation

- Project the classifier model to a large population database (US Army; 3,890 Males, 1,712 Females)
- Count fit vs. unfit cases and estimate the accommodated proportion of the crew population
- This method enables identifying marginally fitting cases, i.e.,  $\text{Prob}(\text{Fit}) \approx 0.5$  and fit surface gradient
- This new information can help to identify the design issues and iteratively optimize the suit design

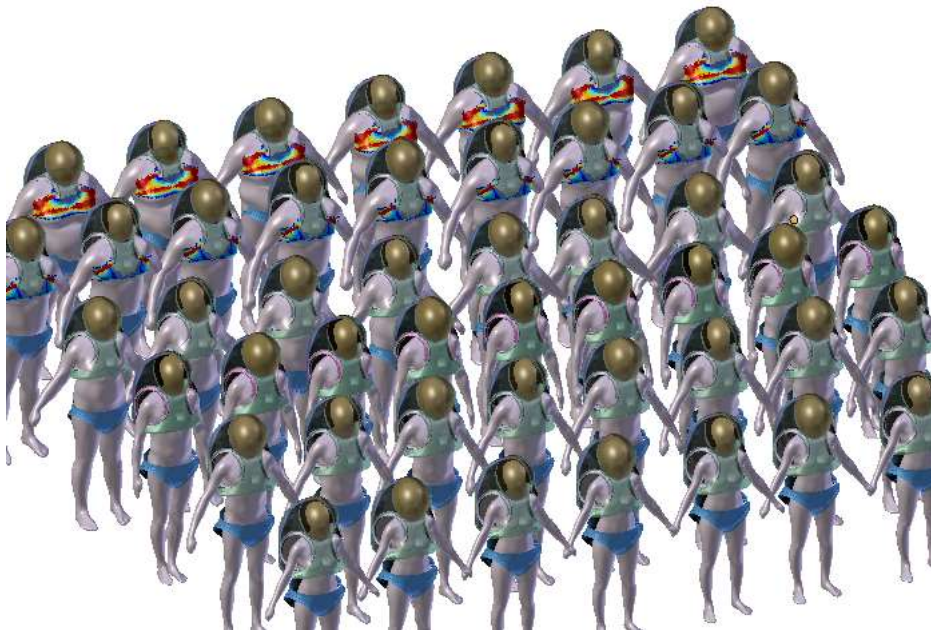

US Army Scan Database

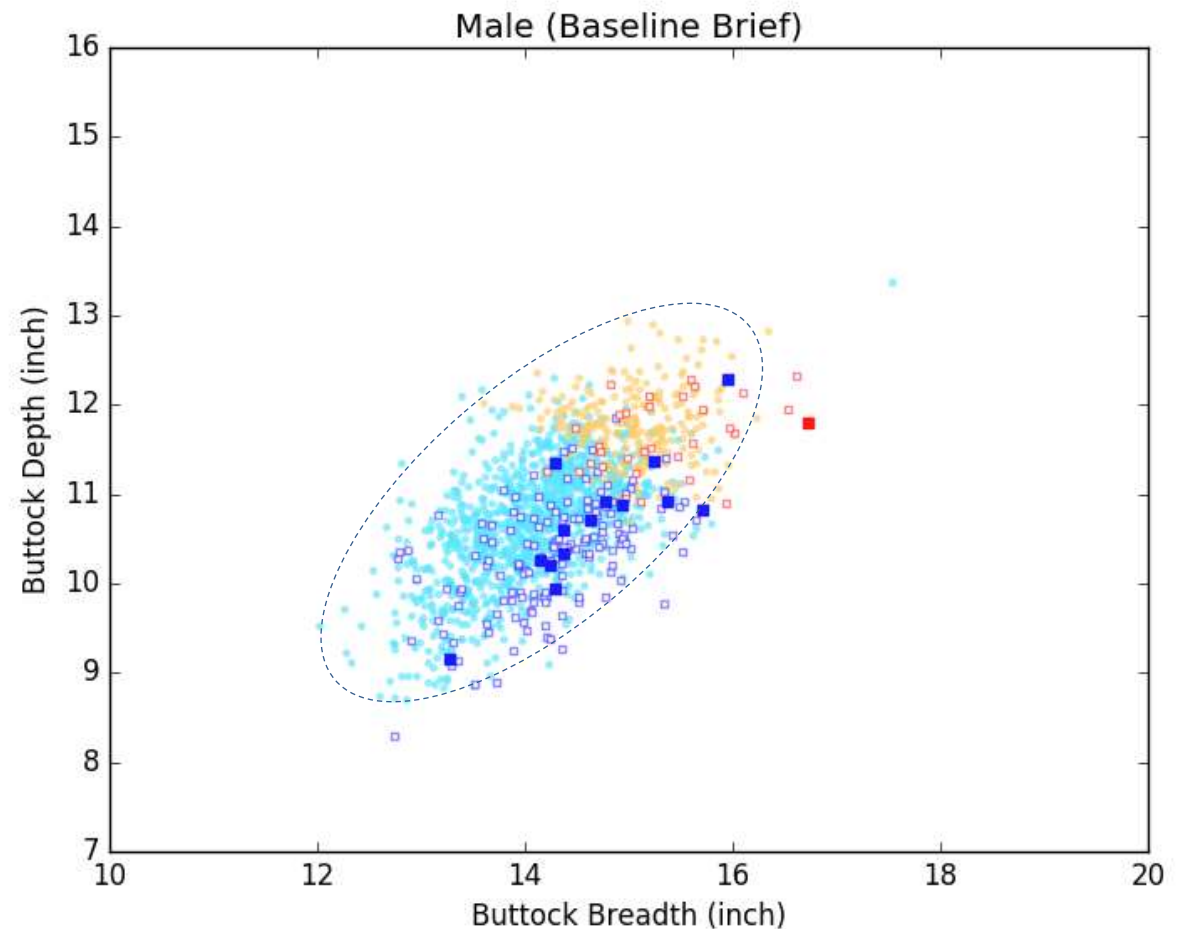

# Skin Compression Tolerance



- Suit-to-body overlap is a key metric, but the specific magnitude of acceptable overlap is still unknown
- This study directly measured the maximum tolerable depth of overlap by maximally “pushing” a probe
- Developed a parametric model and the outcome was compared to the virtual fit tests

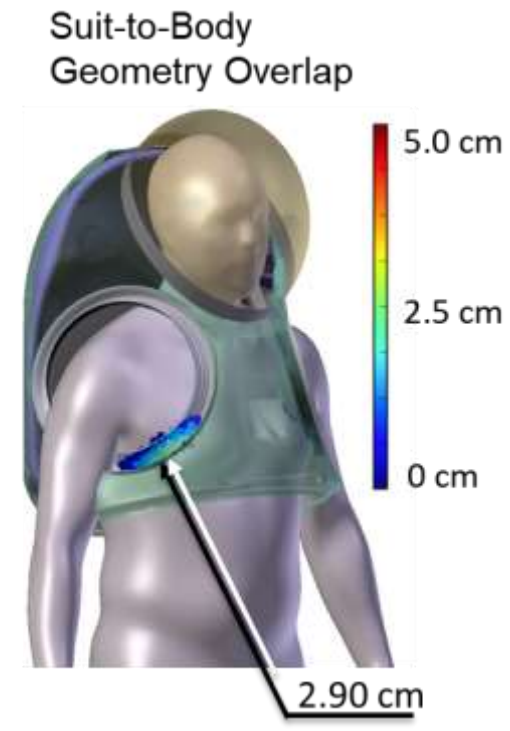
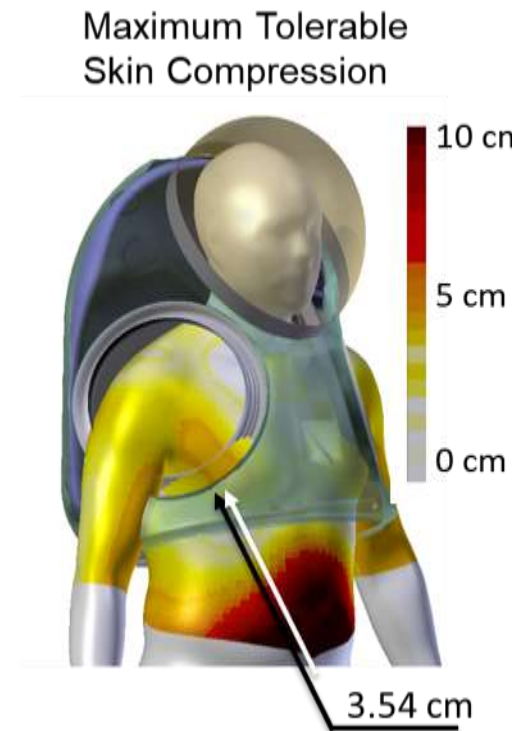
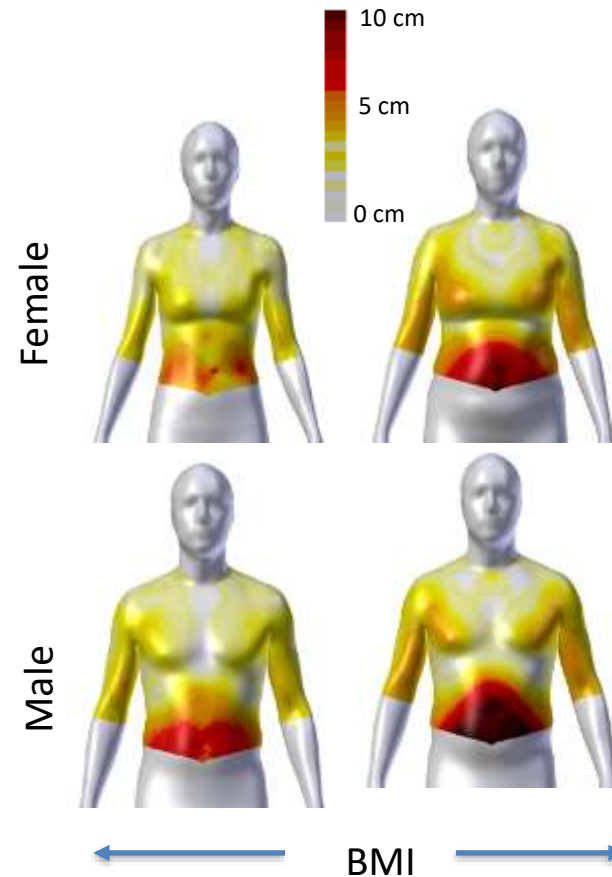

# Subjective Reporting of Suit-to-Body Contact

- Physically tested subjects also reported the perceived locations of suit-to-body contacts
- The subjective reporting was compared to physical and virtual suit contact and overlap

Subjective Reporting of Suit-to-Body Contacts

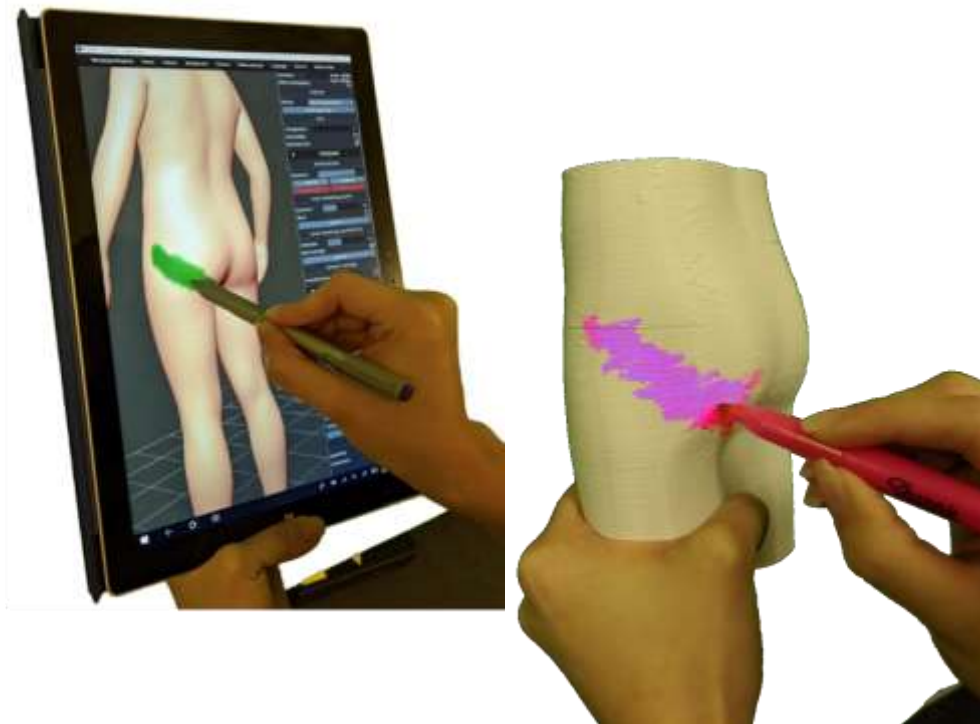

Compare Outcome to the Virtual Suit-to-Body Overlap



# Panelist – Rachel Vitali



[vitalir@umich.edu](mailto:vitalir@umich.edu)

# Topic 1 – Lunar EVAs



- **What sizing and fit challenges are likely to be unique to planetary suits working in partial gravity?**
- **How will forceful exertions and extreme postures influence fit?**



Subject walking on reduced gravity aircraft



Subject crawling in prototype planetary suit (1-g)

## Topic 2 - Suit-Body Contact Assessment



- How do we discriminate 'good' vs. 'bad' suit-body contact?
- How do the anatomical properties of the contact location change suit fit (for example, bone vs. soft tissue)

Maximum Tolerable Skin Compression

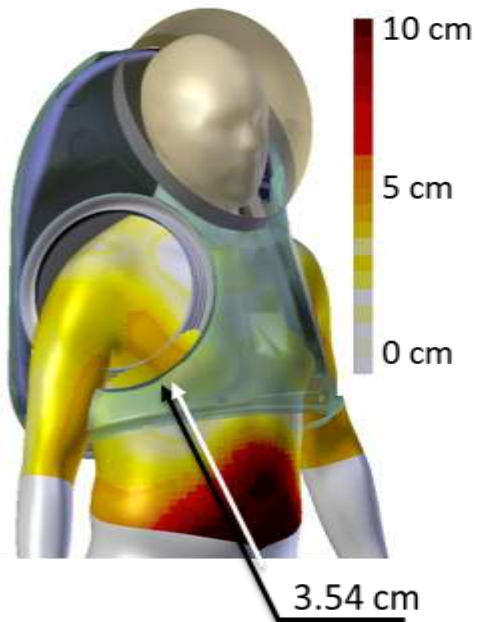

Suit-to-Body Geometry Overlap

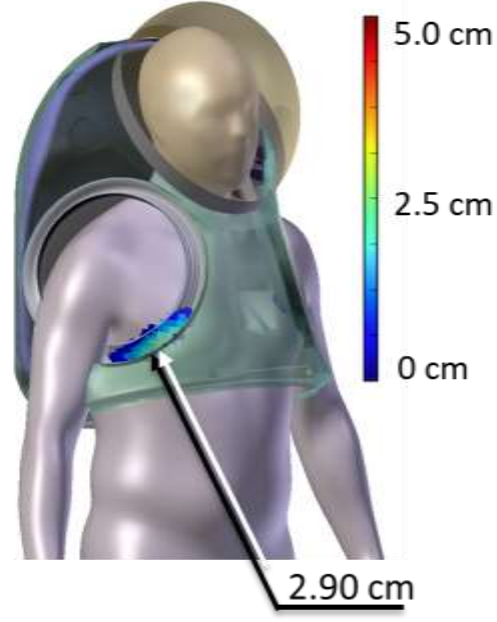

Perceived Suit Contact

# Topic 3 – Custom vs. modular sizing



- Why do we have modular suits, and not custom-fitted suits that are unique to each crewmember?



Apollo era: Custom sewn suits

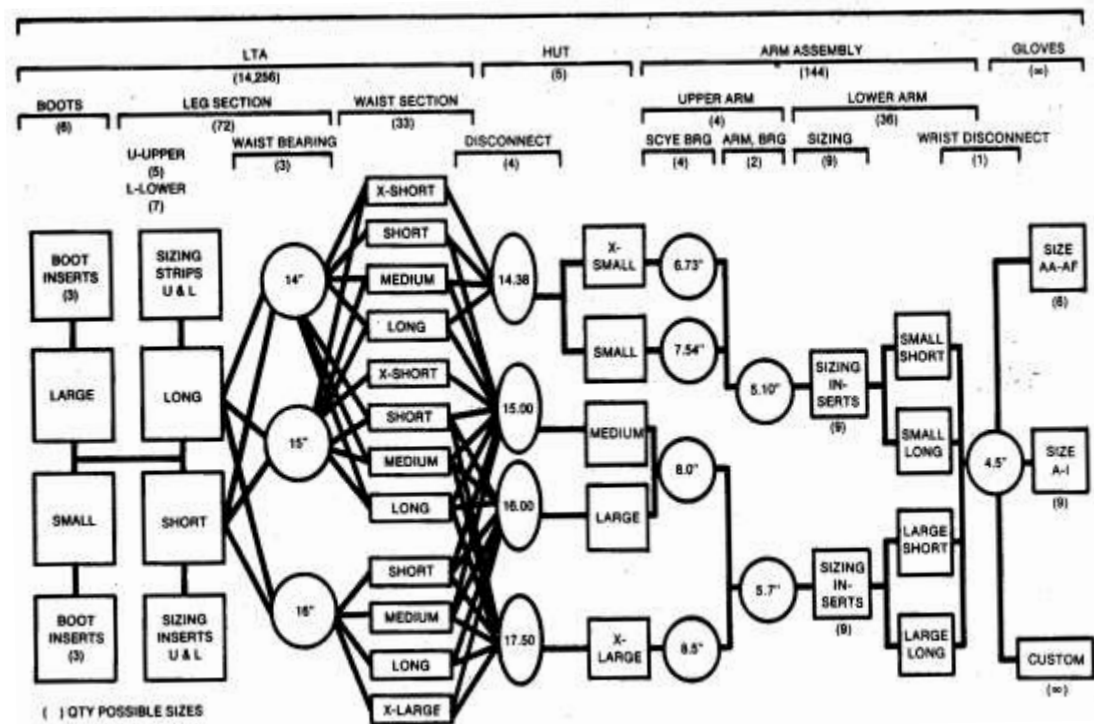

Shuttle Era: Modular suit architecture

## Topic 4 – Other disciplines



- What are examples of other fields that have similar fit and sizing challenges, and how have they worked to resolve these issues?



*Firefighting*



*Exoskeletons*



*Military*



# Questions?



- **Panelists:**

- Richard Rhodes ([Richard.Rhodes@NASA.gov](mailto:Richard.Rhodes@NASA.gov))
- Han Kim ([Han.Kim@NASA.gov](mailto:Han.Kim@NASA.gov))
- Rachel Vitali ([vitalir@umich.edu](mailto:vitalir@umich.edu))